



DEPARTMENT OF LABOR & ECONOMIC GROWTH
DIRECTOR'S OFFICE
CONSTRUCTION SAFETY STANDARDS

Filed with the Secretary of State on August 31, 1976 (as amended September 26, 1983) (as amended July 3, 1985) (as amended July 12, 1988) (as amended July 20, 1995) (as amended September 3, 1996) (as amended January 15, 1999) (as amended December 27, 2000).

These rules take effect 7 days after filing with the Secretary of State
(By authority conferred on the director of the department of consumer and industry services by sections 19 and 21 of 1974 PA 154 and Executive Reorganization Order No. 1996-2, MCL 408.1019, 408.1021, and 445.2001) R 408.41001a,

R 408.41005a, R 408.41014a, R 408.41015a, R 408.41018a, R 408.41020a, R 408.41023a, R 408.41025a, R 408.41031a, R 408.41065a, R 408.41071a, R 408.41072a, and R 408.41077a, of the Michigan Administrative Code are amended as follows: Bureau of Safety and Regulation,

Visit our web site at: www.michigan.gov/mioshastandards

PART 10. LIFTING AND DIGGING EQUIPMENT

TABLE OF CONTENTS

R 408.41001a Adoption of federal OSHA standards.	2	R 408.41026a Locomotive and truck cranes; lifting restrictions.	17
R 408.41002a Scope.	3	R 408.41027a Mobile hydraulic crane; operating requirement.	17
R 408.41003a Definitions; A to J.	3	R 408.41028a Hammerhead tower crane; operating requirement.	17
R 408.41004a Definitions; L to W.	5	R 408.41029a Portal, tower, or pillar cranes; requirements for leaving crane unattended; wind speed operating restriction.	18
R 408.41005a Adoption of standards.	5	R 408.41030a Overhead and gantry cranes; operating requirements.	18
R 408.41006a Employer responsibilities.	6	R 408.41031a Floating cranes and floating derricks; leaving crane or derrick unattended; rated load capacity of barge-mounted mobile crane; provision of load rating chart; compliance with employee protection requirements.	18
R 408.41007a Employee responsibilities.	6	R 408.41032a Hooks and shackles.	19
R 408.41008a Operator training.	6	R 408.41033a Wire rope generally.	19
R 408.41009a Employer responsibility for employee crane, derrick, or excavation equipment knowledge and ability.	6	R 408.41051a Inspections generally, excavation equipment.	19
R 408.41010a Equipment operator conduct.	6	R 408.41065a Material and personnel hoists generally.	19
R 408.41011a Signals.	7	R 408.41066a Employer responsibility.	20
R 408.41012a Inspections generally.	10	R 408.41067a Employee responsibility.	20
R 408.41013a Wire rope inspection.	12	R 408.41068a Operator training.	20
R 408.41014a Marking rated capacity.	12	R 408.41069a Operator conduct.	20
R 408.41015a Work platforms generally.	12	R 408.41070a Signals.	20
R 408.41016a Work platforms; load test requirements; trial lift; inspections; proof testing.	13	R 408.41070b Material hoists.	20
R 408.41017a Work platforms; communication requirements.	14	R 408.41071a Inspections.	21
R 408.41018a Work platforms; safety equipment; travel rate; crane operator; platform load; arc welding; crane operation; adverse weather conditions; leaving suspended platform.	14	R 408.41072a Personnel hoists generally.	21
R 408.41019a Work platforms; use of derricks.	15	R 408.41073a Bridge tower personnel hoists.	21
R 408.41020a Work platforms; derrick hoist machine requirements.	15	R 408.41074a Wire rope.	22
R 408.41021a Work platform and headache ball use generally.	15	R 408.41075a Use of multiple permanent elevators; use of endless belt-type manlifts prohibited.	22
R 408.41022a Headache ball; use by certain employees; signalperson.	15	R 408.41077a Base-mounted drum hoists.	22
R 408.41023a Energized parts clearances; grounding and notification.	15	R 408.41099a Rescissions.	22
R 408.41024a Swing radius clearance.	16	APPENDIX A	23
R 408.41025a Crane, derrick, and excavating equipment; operating rules generally.	16		

R 408.41001a Adoption of federal OSHA standards.

Rule 1001a. (1) The provisions of 29 C.F.R. §§1926.555 and 1910.183, except as amended in this rule, are adopted by reference in these rules. The federal construction and general industry standards are available at no charge as of the time of adoption of these rules from the Michigan Department of Consumer and Industry Services, 7150 Harris Drive, Box 30643, Lansing, Michigan 48909, or from the United States Department of Labor, Occupational Safety and Health Administration, 801 S. Waverly Road, Lansing, Michigan 48917.

(2) As of the effective date of this part, subpart G referenced in the provisions of 19 C.F.R. §1926.555 means Part 22. "Signals, Signs, Tags, and Barricades" of the rules of the construction safety standards commission, being R 408.42201 et seq. of the Michigan Administrative Code.

REFERENCES	
Federal OSHA	Michigan Construction Safety Standards Commission
29 C.F.R. §1926.555 Subpart G	Part 22. Signals, Signs, Tags, and Barricades.

(3) The provisions of 29 C.F.R. §1926.556, as incorporated by reference under section 14(1) of Act No. 154 of the Public Acts of 1974, as amended, being §408.1014(1) of the Michigan Compiled Laws, are hereby rescinded as authorized by section 14(1).

(4) The provisions of 29 C.F.R. §1926.555 Conveyors, are amended to read as follows:

- (a) Means for stopping the motor or engine shall be provided at the operator's station. Conveyor systems shall be equipped with an audible warning signal to be sounded immediately before starting up the conveyor.
- (b) If the operator's station is at a remote point, the employer shall provide similar provisions for stopping the motor or engine at the motor or engine location.
- (c) Emergency stop switches shall be arranged so that the conveyor cannot be started again until the actuating stop switch has been reset to running or the "on" position.
- (d) Screw conveyors shall be guarded to prevent employee contact with turning flights.
- (e) Where a conveyor passes over work areas, aisles, or thoroughfares, the employer shall provide suitable guards to protect employees required to work below the conveyors.
- (f) The employer shall ensure that all crossovers, aisles, and passageways are conspicuously marked by suitable signs, as required by subpart G of this part.
- (g) The employer shall ensure that conveyors are locked out or otherwise rendered inoperable, and tagged out with a "DO NOT OPERATE" tag during repairs and when operation is hazardous to employees performing maintenance work.
- (h) All conveyors in use shall meet the applicable requirements for design, construction, inspection, testing, maintenance, and operation, as prescribed in the ANSI Standard B20.1, "Safety Standard for Conveyors, and Related Equipment," 1996 edition.

(5) Helicopters. The provisions of 29 C.F.R. §1910.183 are amended to read as follows:

- (a) Helicopter cranes shall be in compliance with all applicable regulations of the Federal Aviation Administration.
- (b) The employer shall ensure that before each day's operation of a helicopter, a briefing is conducted. The briefing shall set forth the plan of operation for the pilot and ground personnel.
- (c) Helicopter loads shall be properly slung. A tag line shall be of a length that the tag line shall not be drawn up into the rotors. Pressed sleeve, swedged eyes, or equivalent means shall be used for all freely suspended loads to prevent hand splices from spinning open or cable clamps from loosening.
- (d) All electrically operated cargo hooks shall have the electrical activating device designed and installed to prevent inadvertent operation. In addition, the cargo hooks shall be equipped with an emergency mechanical control for releasing the load. The employer shall ensure that the hooks are tested before each day's operation by a competent person to determine that the release functions properly, both electrically and mechanically.
- (e) Both of the following provisions apply to personal protective equipment:
 - (i) The employer shall provide personal protective equipment and the employer shall ensure its use by employees receiving the load. Personal protective equipment shall consist of complete eye protection and hardhats secured by chinstraps and shall be provided for as prescribed in construction safety standard, Part 6. "Personal Protective Equipment," being R 408.40601 et seq. of the Michigan Administrative Code.
 - (ii) Loose-fitting clothing likely to flap in rotor downwash, and thus be snagged on the hoist line, shall not be worn.
- (f) The employer shall take all necessary precautions to protect employees from flying objects in the rotor downwash. All loose gear which is within 100 feet of where the load is lifted or deposited or which is within any other area susceptible to rotor downwash shall be secured or removed.
- (g) The employer shall ensure that good housekeeping is maintained in all helicopter loading and unloading areas.
- (h) The size and weight of loads and the manner in which loads are connected to the helicopter shall be checked. A lift may not be made if the helicopter operator believes the lift cannot be made safely.
- (i) An employer shall assure that a safe means of access is provided for employees to reach the hoist line hook and engage or disengage cargo slings when an employee is required to perform work under a hovering craft. Employees shall not perform work under a hovering craft, except when necessary to hook or unhook loads.
- (j) Static charge on the suspended load shall be dissipated with a grounding device before ground personnel touch the suspended load, unless protective rubber gloves that are provided for as prescribed in construction safety standard, Part 6. "Personal Protective Equipment," being R 408.40601 et seq. of the Michigan Administrative Code, are being worn by all personnel who may be required to touch the suspended load.

- (k) The weight of an external load shall not exceed the helicopter manufacturer's rating.
- (l) Hoist wires or other gear, except for pulling lines or conductors that are allowed to pay out from a container or roll off a reel, shall not be attached to any fixed ground structure and shall not be allowed to foul on any fixed structure.
- (m) The employer shall instruct and ensure, that when visibility is reduced by dust or other conditions, ground personnel and other employees shall exercise special caution to keep clear of the main and stabilizing rotors. The employer shall take precautions to eliminate, as far as practical, the dust or other conditions reducing the visibility.
- (n) An employer shall instruct the aircrew and ground personnel on the signal systems to be used and shall review the systems with the employees in advance of hoisting the load. This subdivision applies to both radio and hand signal systems. Hand signals, where used, shall be as shown in figure 1.
- (o) The employer shall ensure that no employee shall approach within 50 feet of a helicopter when the rotor blades are turning, unless his or her work duties require his or her presence in that area.
- (p) The employer shall instruct employees, and shall ensure, that when approaching or leaving a helicopter that has its blades rotating, all employees shall remain in full view of the pilot and keep in a crouched position. An employee shall not be permitted to work in the area from the cockpit or cabin rearward while blades are rotating, unless authorized by the helicopter operator to work there.
- (q) The employer shall provide sufficient ground personnel to ensure that helicopter loading and unloading operations can be performed safely.
- (r) There shall be constant reliable communication between the pilot and the designated employee of the ground crew who acts as a signalman during the period of loading and unloading. The signalman shall be clearly distinguishable from other ground personnel.
- (s) The employer shall prohibit open fires in areas where the fires could be spread by the rotor downwash.

CRANES AND DERRICKS AND EXCAVATION EQUIPMENT

R 408.41002a Scope.

Rule 1002a. This part applies to the operation, use, and maintenance of cranes, derricks, material and personnel hoists, including elevators, and excavation equipment used in construction operations.

R 408.41003a Definitions; A to J.

Rule 1003a. (1) "Authorized" means appointed by a duly constituted administrative or regulatory authority.

(2) "Base" means the mounting flanges or feet for attachment of a hoist to the machine's supporting structure or foundation.

(3) "Base-mounted drum hoist" means a self-contained lifting unit which has a motor, a drum to receive the lifting cable, and mounting flanges for anchoring.

(4) "Boom" means a member which is hinged to the rotating superstructure and which is used for supporting the excavation buckets, tools, and accessories.

(5) "Boom (crane)" means a member which is hinged to the rotating superstructure and which is used for supporting the hoisting tackle.

(6) "Boom hoist mechanism" means a device for supporting the boom and controlling the boom angle.

(7) "Boom point" means the outer extremity of the crane boom that contains the hoist sheave assembly.

(8) "Boom stop" means a device that is used to limit the angle of the boom at the highest recommended position.

(9) "Brake" means a device used for retarding or stopping motion by friction or power means.

(10) "Clutch" means a device for the engagement or disengagement of power.

(11) "Commercial truck-mounted crane" means a crane which consists of a rotating superstructure (center post or turntable), a boom, operating machinery, and 1 or more operator's stations, which is mounted on a frame that is attached to a commercial truck chassis, which usually retains a payload hauling capability, and which has a power source that usually powers the crane. The crane's function is to lift, lower, and swing loads at various radii.

(12) "Counterweight" means a weight that is used to supplement the weight of the machine in providing stability for lifting working loads.

(13) "Crawler crane" means a crane which consists of a rotating superstructure that has a power plant, operating machinery, and a boom and which is mounted on a base and equipped with crawler treads for travel. The crane's function is to lift, lower, and swing loads at various radii.

(14) "Crawler excavator" means a device which consists of a rotating superstructure that has a power plant, operating machinery, and a boom, and which is mounted on a base, and which is equipped with crawler treads for travel. The function of the excavator is to dig, lift, lower, and swing loads at various radii.

(15) "Crosshead" means an overhead structural member that supports the hoist platform to which the hoisting or load cables are attached.

(16) "Deadman control" means a device that stops and locks the machinery when the control is released.

(17) "Derrick" means an apparatus which consists of a mast or equivalent member held at the head by guys or braces, with or without a boom, and which is used with a hoisting mechanism and operating ropes.

(18) "Designated" means selected or assigned by the employer or the employer's representative as being qualified to perform specific duties.

(19) "Direct geared hoist" means a hoist that has a drum geared directly to the machine's power source.

(20) "Drum" means the cylindrical member around which rope is wound for lifting or lowering the load or boom or swinging the boom supporting structure.

(21) "Drum capacity" means the length of a specific diameter of rope that can be wound on a drum.

(22) "Dynamic loading" means the loads introduced into the machine or its components by forces in motion.

(23) "Elevator" means the machinery, construction, apparatus, equipment, or device serving 2 or more landings used in raising and lowering a car, cage, or platform which is guided. It includes a personnel elevator material hoist, and other lifting or lowering apparatus which is guided.

(24) "Elevator journey person" means a person who is licensed by the State of Michigan to perform, or to provide supervision in the performance of the work of installation, alteration, maintenance, repair, servicing, adjusting, inspecting, and testing of elevators.

(25) "Flange point" means a point of contact between the rope and the drum flange where the rope changes layers.

(26) "Friction drum hoist" means a hoist which has a drum that is controlled by friction clutches and brakes and which is provided with drum ratchets and pawls.

(27) "Gudgeon pin" means a pin that is used to connect the base of a boom to the main frame.

(28) "Headache ball" means a weight that is attached to the load line to cause the unloaded line to lower by gravity.

(29) "Hoist" means a system of power driven drums, gears, cables, chains, or hydraulic cylinders capable of lifting and lowering loads.

(30) "Hoist tower" means a vertical structure used to support or house the platform and cab of an elevator or hoist.

(31) "Jib" means an extension that is attached to the boom point to provide added boom length for lifting specified loads. The jib may be in line with the boom or offset to various angles in the vertical plane of the boom.

FIGURE 1
HELICOPTER HAND SIGNALS

**MOVE
RIGHT**



Left arm extended horizontally; right arm sweeps upward to position over head.

**MOVE
LEFT**



Right arm extended horizontally; left arm sweeps upward to position over head.

**MOVE
FORWARD**



Combination of arm and hand movement in a coinciding motion pulling toward body.

**MOVE
REARWARD**



Hands above arm, palms out using a noticeable shoving motion.

**RELEASE
SLING
LOAD**



Left arm held down away from body, right arm cuts across left arm in a slashing movement from above.

**HOLD-
HOVER**



The signal "hold" is executed by placing arms over head with clenched fists.

TAKEOFF



Right hand behind back; left hand pointing up.

LAND



Arms around in front of body and pointing downward.

**MOVE
UPWARD**



Arms extended, palms up; arms moving up.

**MOVE
DOWNWARD**



Arms extended; palms down; arms sweeping down.

R 408.41004a Definitions; L to W.

Rule 1004a. (1) "Landing" means the floor or stage elevation at which the cab or platform can be entered.

(2) "Limit switch" means a device used to interrupt or stop the travel of the load by automatically cutting power from the power source and applying the brakes.

(3) "Load rating" means the crane ratings in pounds (kilograms) established by the manufacturer.

(4) "Lockout device" means a positive mechanical method for disconnecting the power supply.

(5) "Locomotive crane" means a crane which consists of a rotating superstructure that has a power plant, operating machinery, and a boom and which is mounted on a base or car that is equipped for travel on a railroad track. A locomotive crane may be self-propelled or propelled by an outside source. The crane's function is to lift, lower, and swing loads at various radii.

(6) "Material hoist" means a mechanism for use in the hoisting or lowering of construction or demolition material. A material hoist is equipped with a platform, car, cage, or bucket that moves vertically on guide members.

(7) "Outriggers (stabilizers)" means extendable or fixed members which are attached to the mounting base and which rest on supports at the outer ends that are used to support the crane or elevator.

(8) "Pawl (dog)" means a device for positively holding a member against motion in 1 or more directions.

(9) "Personnel hoist" means a type of elevator which is used for the raising or lowering of personnel and or materials and which is guided.

(10) "Power-controlled lowering" means a system or device in the power train, other than the load hoist brake, that can control the lowering rate of speed of the load hoist mechanism.

(11) "Qualified person" means a person who, through attainment of a recognized degree or certificate of professional standing or by extensive knowledge, training, and experience, has successfully demonstrated the ability to solve or resolve problems relating to the subject matter and work.

(12) "Rail clamp" means a tong-like metal device which is mounted on a locomotive crane car and which can be connected to the track.

(13) "Rated load" means the maximum load permitted by the manufacturer's specifications and by the provisions of Act No. 227 of the Public Acts of 1967 and Public Act No. 333 of the Public Acts of 1976, being §§408.801 et seq. and 338.2151 et seq., respectively, of the Michigan Compiled Laws.

(14) "Rated rope (line) pull" means the manufacturer's recommended load in pounds (kilograms) applied to the rope attached to the hoist drum.

(15) "Reeving" means a rope system in which the rope travels around drums and sheaves.

(16) "Rotation resistant rope" means a wire rope consisting of an inner layer of strands laid in one direction covered by a layer of strands laid in the opposite direction which has the effect of counteracting torque by reducing the tendency of the finished rope to rotate.

(17) "Running rope" means a rope that travels around sheaves or drums.

(18) "Safety device" means a device used to prevent the unwanted or unsafe operation of a piece of equipment.

(19) "Safety factor" means a ratio of the allowable working load to the ultimate strength of the device.

(20) "Signal system" means an audible or visual method of communication between the equipment operator and the persons on the landing or floors.

(21) "Spooling rope" means a winding of rope on a cylindrical drum in evenly spaced, uniform layers.

(22) "Standing (guy) rope" means a supporting rope that maintains a constant distance between the points of attachment to the 2 components connected by the rope.

(23) "Swing" means the rotating of a boom structure to move a load in a horizontal arc about the axis of rotation.

(24) "Tackle" means an assembly of ropes and sheaves arranged for lifting, lowering, and pulling.

(25) "Telescoping boom" means a base boom from which 1 or more boom sections are extended for additional length.

(26) "Tie-in" means a rigid device used to affix the hoist tower to the structure.

(27) "Two-blocking" means the condition in which the lower load block or hook assembly comes in contact with the upper load block or boom point sheave assembly.

(28) "Wheel-mounted carrier crane (multiple-control stations)" means a crane which consists of the rotating superstructure, operating machinery, and operator's station and boom and which is mounted on a crane carrier that is equipped with axles and rubber-tired wheels for travel, a power source, and separate stations for driving and operating. The crane's function is to lift, lower, and swing loads at various radii.

(29) "Wheel-mounted carrier crane (single-control station)" means a crane which consists of a rotating superstructure, operating machinery, and boom and which is mounted on a crane carrier that is equipped with axles and rubber-tired wheels for travel, a power source, and a single-control station for driving and operating. The crane's function is to lift, lower, and swing loads at various radii.

(30) "Winch head" means a rotating cylindrical drum which has curved end flanges and which is used for load handling by means of fiber rope coiled about its barrel with hand tension applied to the nonload end.

(31) "Working load" means external load, in pounds (kilograms) or tons (metric tons), applied to a hoist, including the weight of auxiliary load attaching equipment.

R 408.41005a Adoption of standards.

Rule 1005a. (1) The standards specified in this rule are adopted by reference. They are available from Global Engineering Documents, 15 Inverness Way East, Englewood, Colorado, United States, 80112, Web-site: WWW.GLOBAL.IHS.COM at a cost as of the time of adoption of these rules of \$82.00, \$73.00, \$73.00, \$73.00, \$63.00, \$73.00, \$76.00, \$199.00, \$107.00, \$83.00, \$45.00, \$59.00, and \$49.00 respectively; or for review at the Michigan Department of Consumer and Industry Services, Standards Division, 7150 Harris Drive, Lansing, Michigan 48909.

(2) All crawler, locomotive, and truck cranes in use shall be in compliance with the requirements of the ANSI standard B30.5 "Mobile and Locomotive Cranes," 1994 edition.

(3) All mobile hydraulic cranes in use shall be in compliance with the requirements of ANSI standard B30.5 "Mobile and Locomotive Cranes," 1994 edition, except that all new mobile hydraulic cranes manufactured after August 5, 1995 shall have a positive-acting device that prevents contact between the load block or ball and the boom tip (anti-2-blocking device) or a system shall be used that deactivates the hoisting action before damage occurs in the event of a 2-blocking situation (2-blocking prevention feature).

(4) All hammerhead tower cranes in use shall be in compliance with the requirements of ANSI standard B30.3 "Construction Tower Cranes," 1996 edition.

(5) All portal, tower, and pillar cranes shall be in compliance with the requirements of ASME standard B30.4 "Portal, Tower and Pillar Cranes," 1996 edition.

(6) All overhead and gantry cranes in use shall be in compliance with the requirements of ANSI standard B30.2 "Overhead and Gantry Cranes," 1996 edition.

(7) All derricks in use shall be in compliance with the requirements of ANSI standard B30.6 "Derricks," 1995 edition.

(8) All floating cranes and floating derricks in use shall be in compliance with the requirements of ANSI standard B30.8 "Floating Cranes and Floating Derricks," 1999 edition.

(9) All base-mounted drum hoists in use shall be in compliance with the requirements of ASME standard B30.7 "Base Mounted Drum Hoists," 1994 edition.

(10) Permanent elevators under the care and custody of the employer and used by employees for work covered by this part shall be in compliance with the requirements of ANSI standard A17.1 "Safety Code/Elevator and Escalators," 1996 edition and be inspected in accordance with the requirements of ANSI standard A17.2 "Inspectors Manual for Elevators and Escalators," 1988 edition, and ANSI standard A17.2.1 "Inspectors Manual for Electric Elevators," 1996 edition.

(11) All material hoists shall be in compliance with the requirements of ANSI standard A10.5 "Safety Requirements for Material Hoists," 1992 edition.

(12) All side boom tractors in use shall be in compliance with the requirements of ASME standard B30.14 "Side Boom Tractors," 1996 edition.

(13) All personnel hoists shall be in compliance with the requirements of ANSI A10.4 "Safety Requirements for Personnel Hoists and Employee Elevators for Construction and Demolition Operations" 1990 edition.

R 408.41006a Employer responsibilities.

Rule 1006a. (1) An employer shall comply with the manufacturer's specifications and limitations applicable to the operation of cranes, derricks, and excavation equipment. If a manufacturer's specifications are not available, then the limitations assigned to the equipment shall be based on the determination of a qualified engineer who is competent in the field of equipment limitations, and the determination shall be appropriately documented and recorded. Attachments that are used with cranes or derricks shall not exceed the capacity, rating, or scope recommended by the manufacturer.

(2) An employer shall designate a qualified person to perform all inspections of cranes and derricks and excavation equipment as required by this part.

(3) An employer shall limit the use of a crane or derrick or excavation equipment to the following entities:

- (a) An employee who has been trained and qualified to operate the type of crane or derrick or excavation equipment to which he or she is assigned.
- (b) A learner who is under the direct supervision of a designated operator.
- (c) Authorized maintenance personnel while performing their duties.

(4) An employer shall maintain a crane or derrick or excavation equipment and its accessories in a condition that will not endanger an operator or other employees.

(5) The original safety factor of the equipment shall not be reduced if modifications or changes are made to the equipment. Modifications or changes shall be certified by a qualified registered engineer. The capacity, operation, and maintenance instruction plates, tags, or decals shall be changed accordingly to reflect any modifications or changes.

(6) An employer shall comply with all other applicable requirements of this part.

(7) An employer shall comply with the requirements of the power crane and shovel associations' mobile hydraulic crane standard no. 2. The standard is available from the

Power Crane and Shovel Association, Bank One Plaza, 111 E. Wisconsin Avenue, Suite 940, Milwaukee, Wisconsin 53202, or from the Standards Division, Michigan Department of Consumer and Industry Services, P.O. Box 30643, Lansing, Michigan 48909, at a cost as of the time of adoption of this rule of \$15.00.

(8) The manual provided by the crane manufacturer shall be readily accessible for the crane operator's reference at the work site.

R 408.41007a Employee responsibilities.

Rule 1007a. (1) An operator shall report any recognized defects of a crane, derrick, or excavation equipment to the supervisor.

(2) An unauthorized employee shall not enter a crane, derrick cab, or excavation equipment.

(3) An unauthorized employee shall not ride on any exterior part of a crane or derrick.

(4) An employee shall remain clear of excavation equipment at all times unless the employee is operating the equipment.

R 408.41008a Operator training.

Rule 1008a. An employer shall assure that a prospective operator, before assignment as an operator of a crane, derrick, or excavation equipment, has been trained in all of the following areas:

- (a) The capabilities of equipment and attachments.
- (b) The purpose, use, and limitations of controls.
- (c) How to make daily inspections.
- (d) Practice in operating assigned equipment to perform the functions necessary for required jobs.
- (e) Applicable state standards and company rules and regulations.

R 408.41009a Employer responsibility for employee crane, derrick, or excavation equipment knowledge and ability.

Rule 1009a. An employer shall ensure that an employee has adequate knowledge of, and is capable of operating, cranes, derricks, or excavation equipment before assigning an employee to a crane, derrick, or excavation equipment.

R 408.41010a Equipment operator conduct.

Rule 1010a. (1) An equipment operator shall not engage in any practice that will divert the operator's attention while actually operating equipment.

(2) Each equipment operator shall be responsible for those operations that are under the operator's direct control. When there is any doubt as to safety, an operator shall stop operations and consult with the supervisor before continuing work.

(3) An equipment operator shall not leave equipment unattended unless the operator is notified by the responsible supervisor that it is safe to do so. Before leaving, the operator shall do all of the following:

- (a) Land any attached load, except as provided in R 408.41025a(2).
- (b) Disengage clutches.
- (c) Put the controls in the off or neutral position.
- (d) Open the main switch or stop the engine.
- (e) Engage manual locking devices in the absence of automatic holding equipment.

(4) When there is a warning sign or lockout on the switch or engine starting controls, an equipment operator shall not close the switch or start operations until the sign has been removed by the person who placed it there.

(5) Before closing the switch or starting the equipment, an operator shall put all controls in the off or neutral position and shall make sure that all personnel are in the clear.

(6) If power fails during operation, an equipment operator shall do all of the following:

- (a) Set all brakes and locking devices.
- (b) Move all clutch or other power controls to the off or neutral position.
- (c) Communicate with the responsible supervisor in charge of equipment operations.
- (d) If practical, and applicable, land the load under brake control.

(7) An equipment operator shall be familiar with the equipment and its proper care. If adjustments or repairs are necessary or if any defects are known, the operator shall report the needed adjustments or repairs or the defects to the responsible supervisor and, upon changing shifts, notify the next operator of the defects.

(8) All controls shall be tested by an operator before beginning a new shift. Any controls that do not operate properly shall be adjusted or repaired before operations are begun.







R 408.41011a Signals.



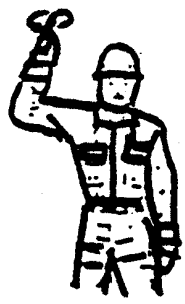

Rule 1011a. (1) An operator shall respond to signals only from the employee who is directing the operation, unless an emergency stop signal is given.



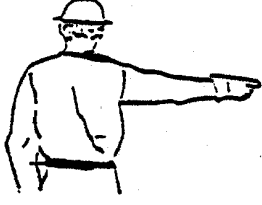

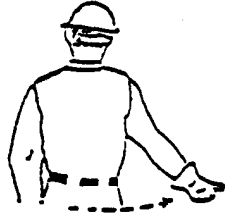
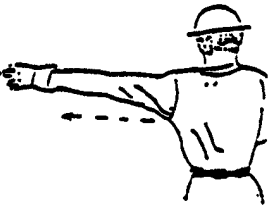
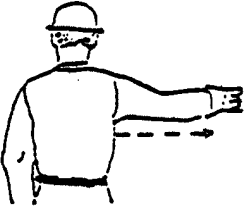
(2) The signals given to an operator of a crane, derrick, or excavation equipment shall be as prescribed in construction safety standard Part 22. Signals, Signs, Tags, and Barricades, being R 408.42201 et seq. of the Michigan Administrative Code.

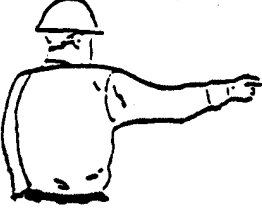
(3) Specialized signals for specified types of cranes or derricks, in addition to those required by Part 22. Signals, Signs, Tags, and Barricades, being R 408.42201 et seq. of the Michigan Administrative Code, are as follows:

- (a) Signals for pile driving or extraction operations are as follows:

 <p>No.1 line (free) up. Arm raised. One finger pointed up and moving in small circle.</p>	 <p>Hammer (no. 2) up. Arm raised. Two fingers pointed and moving in small circle.</p>
 <p>No. 3 line up. Three fingers pointing up and moving in small circle.</p>	 <p>No. 1 line (Free) down. Arm extended downward. One finger pointing down and moving in small circle.</p>
 <p>Hammer (no.2) down. Arm extended downward. Two fingers pointing down and moving in circle.</p>	 <p>No. 3 line down. Arm extended downward. Three fingers pointing down and moving in circle.</p>
 <p>Bow (head) line takeup. While facing center, arm extended downward, fingers curled, and thumb extended. Make back to front arm motion along side of body.</p>	 <p>Stern line takeup. While facing forward, extend arm with forefinger pointing toward stern of vessel.</p>



 <p>Port line takeup. While facing forward with arm extended downward, fingers curled, and thumb extended, make a right-to-left arm motion.</p>	 <p>Starboard line takeup. While facing forward with arm extended downward, fingers curled, and thumb extended, make a left-to-right arm motion.</p>
 <p>Port quarter line takeup. While facing forward, extend left arm with hand open in direction of port quarter.</p>	 <p>Starboard quarter line take up. While facing forward, extend right arm with hand open in direction of starboard quarter.</p>
 <p>Bull line takeup. While facing forward, raise forearm into vertical position holding fist closed</p>	 <p>Bull line slack. While facing forward, extend arm horizontally with fist closed toward side.</p>
 <p>Moonbeam. Use fist in front of body with thumb pointing outward in desired direction of movement.</p>	 <p>Stop. With both arms extended in front of the body, turn hands upward with palms pointing out.</p>

 <p>Stop hammer. With one arm extended in front of body, turn hand upward with palm pointing out. Move hand from side to side.</p>	 <p>Extend spotter. Place both fists in front of body with thumbs pointing outward.</p>
 <p>Retract spotter. Place both fists in front of body with thumbs pointing toward each other.</p>	 <p>Start hammer. Patting top of head.</p>
 <p>Hold. Raised fist.</p>	

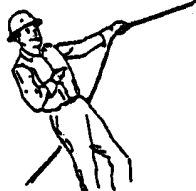
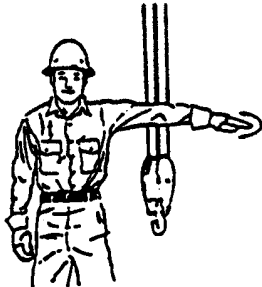
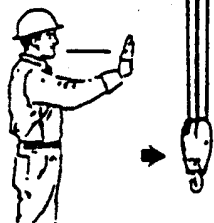

(b) Signals for crawler, locomotive, and truck cranes, mobile hydraulic cranes, and floating cranes and floating derricks are as follows:

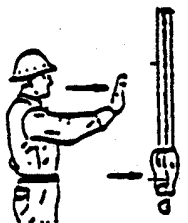
 <p>Extend boom (telescoping boom). One-hand signal. One fist in front of chest with thumb tapping chest.</p>	 <p>Retract boom (telescoping boom). One-hand signal. One fist in front of chest, thumb pointing outward and heel of fist tapping chest.</p>
 <p>Emergency stop. Arm extended, palm down, move hand rapidly right and left.</p>	 <p>Travel. Arm extended forward, hand open and slightly raised, make pushing motion in direction of travel.</p>

(c) Signals for hammerhead tower cranes are as follows:



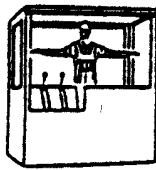
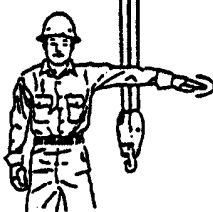
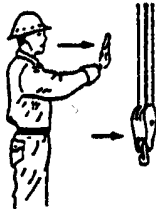

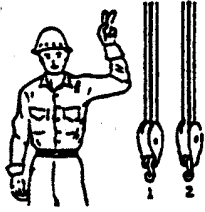



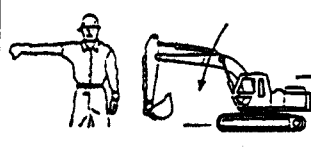
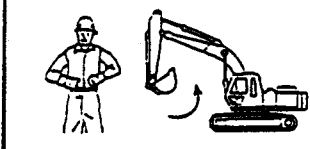
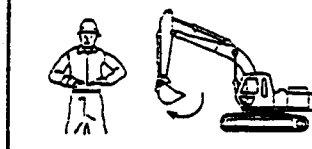
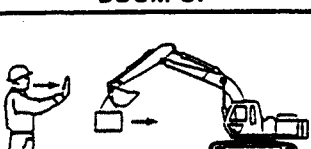
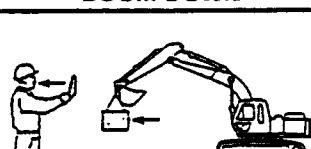
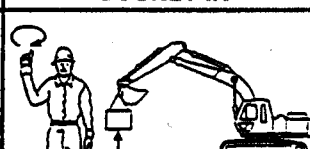
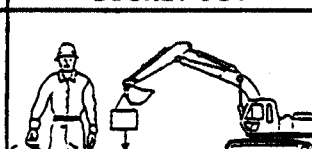
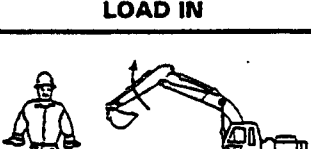
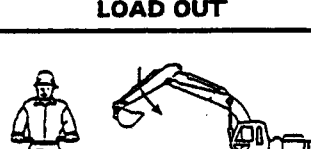
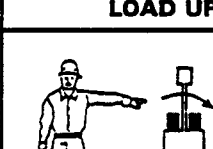

 <p>Tower travel. Arm extended forward, hand open and slightly raised, make pushing motion in direction of travel.</p>	 <p>Trolley travel. Palm up, fingers closed, thumb pointing in direction of motion, jerk hand horizontally.</p>
--	---

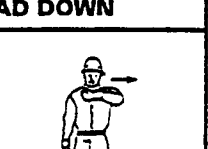
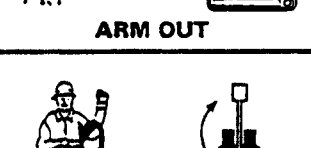
(d) Signals for overhead and gantry cranes are as follows:

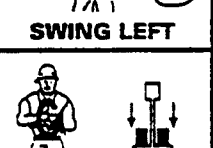
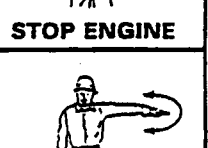
 <p>Magnet is disconnected. Crane operator spreads both hands apart palms up.</p>	 <p>Emergency stop. Arm extended, palm down, move hand rapidly right and left.</p>
 <p>Bridge travel. Arm extended forward, hand open and slightly raised, make pushing motion in direction of travel.</p>	 <p>Trolley travel. Palm up, fingers closed, thumb pointing in direction of motion, jerk hand horizontally.</p>
 <p>Multiple trolleys. Hold up 1 finger for block marked "1" and 2 fingers for block marked "2". Regular signals follow.</p>	

(4) The signals for specified types of excavation equipment, in addition to those required by R 408.42201 et seq. are as follows:

Standard hand signals for controlling crawler excavator operations

 BOOM UP	 BOOM DOWN	 BUCKET IN	 BUCKET OUT	
 LOAD IN	 LOAD OUT	 LOAD UP	 LOAD DOWN	
 ARM OUT	 ARM IN	 SWING RIGHT	 SWING LEFT	 STOP ENGINE
 TURN RIGHT	 TURN LEFT	 TRAVEL AHEAD	 TRAVEL BACK	 STOP
 COUNTER ROTATE RIGHT	 COUNTER ROTATE LEFT	 SLOW ANY FUNCTION	 THIS FAR	 EMERGENCY STOP

(5) A truck crane shall be equipped with an audible signaling device which shall be actuated before traveling without a signalperson and which shall be actuated intermittently during travel. The following signals shall be used when moving a crane:

- (a) Stop1 audible signal.
- (b) Go ahead2 audible signals.
- (c) Back up3 audible signals.

(6) A wired phone system shall be used as a signaling device for derricks.

R 408.41012a Inspections generally.

Rule 1012a. (1) A thorough, annual inspection of a crane, derrick, or excavation equipment shall be made by a qualified person. The employer shall maintain, on the jobsite, a copy of the records of the date and results of the latest inspection for each piece of equipment.

(2) Inspection procedure for cranes, derricks, and excavation equipment in regular service is divided into 2 general classifications based upon the intervals at which inspection should be performed. The intervals in turn are dependent upon the nature of the critical components of the crane, derrick, and excavation equipment and the degree of their exposure to wear, deterioration, or malfunction. The 2 general classifications are designated as "frequent" and "periodic," with respective intervals between inspections as follows:

- (a) Frequent inspection – daily to monthly intervals.
- (b) Periodic inspection – 1 to 12-month intervals or as specifically recommended by the manufacturer.
- (3) All of the following items on a crane, a derrick, or boom-equipped excavation equipment shall be inspected at frequent intervals:
 - (a) All control mechanisms, which shall be inspected daily for misadjustment that interferes with the proper operation of the equipment and for excessive wear of components and contamination by lubricants or other foreign matter.
 - (b) All chords and lacing, which shall be visually inspected daily.
 - (c) All safety devices, which shall be inspected daily for malfunction.
 - (d) Air or hydraulic systems, which shall be inspected daily for deterioration or leakage.
 - (e) Hydraulic and pneumatic hose, fittings, and tubing, which shall be inspected for all of the following:
 - (i) Evidence of leakage at the surface of the flexible hose or its junction with the couplings.
 - (ii) Blistering or abnormal deformation to the outer covering of the hydraulic or pneumatic hose.
 - (iii) Leakage at threaded or clamped joints that cannot be eliminated by normal tightening or by recommended procedures.

- (iv) Evidence of excessive abrasion or scrubbing on the outer surface of a hose, rigid tube, or fitting. Means shall be taken to eliminate the interference of components with each other.
 - (f) Hooks, which shall be inspected daily in compliance with the provisions of R 408.41032a for deformation or cracks.
 - (g) Electrical apparatus, which shall have a frequent inspection for malfunctioning, signs of excessive deterioration, and dirt or moisture accumulation. See subrule (2)(a) of this rule.
 - (h) Guy cables, which shall be inspected daily for tension.
 - (i) The plumb of the mast, which shall be inspected daily.
- (4) The load block wire rope reeving of a crane or derrick shall be inspected daily in accordance with the provisions of R 408.41013a.
- (5) In addition an operator of a crane or derrick shall observe the machinery for any defects or hazards that might appear during operation.
- (6) Any structural or functional defect or other hazard that would adversely affect the safe operation of a crane, derrick, or excavation equipment shall be corrected before operations begin or continue.
- (7) Complete inspections of a crane, derrick, or excavation equipment, as specified in subrules (2) and (8) of this rule, shall be performed periodically or, depending upon the activity that a crane, derrick, or excavation equipment is engaged in, the severity or service, and the environment, at closer intervals. A periodic inspection shall include all of the inspection requirements set forth in subrule (3) of this rule and an inspection for all of the following items:
- (a) Deformed, cracked, or corroded members in the equipment structure and entire boom.
 - (b) Loose bolts or rivets.
 - (c) Cracked or worn sheaves and drums.
 - (d) Worn, cracked, or distorted parts, including any of the following:
 - (i) Pins.
 - (ii) Bearings.
 - (iii) Shafts.
 - (iv) Gears.
 - (v) Rollers.
 - (vi) Locking devices.
 - (e) Excessive wear on brake and clutch system parts, linings, pawls, and ratchets.
 - (f) Significant inaccuracies in the load, boom angle, and other indicators over the full range of the indicators.
 - (g) Excessive wear of chain-drive sprockets and excessive chain stretch.
 - (h) Cracks in crane hooks.
 - (i) Malfunction in travel steering, braking, and locking devices.
 - (j) Excessively worn or damaged tires.
 - (k) All of the following for cracks in hydraulic and pneumatic hoses, fittings, and tubing:
 - (i) Evidence of leakage at the surface of the flexible hose or its junction with the metal end couplings.
 - (ii) Blistering or abnormal deformation to the outer covering of the hydraulic or pneumatic hose.
 - (iii) Leakage at threaded or clamped joints that cannot be eliminated by normal tightening or recommended procedures.
- (iv) Evidence of excessive abrasion or scrubbing on the outer surface of a hose, rigid tube, or fitting. Steps shall be taken to prevent components from interfering with each other.
 - (l) All of the following for hydraulic and pneumatic pumps and motors:
 - (i) Loose bolts or fasteners.
 - (ii) Leaks at joints between sections.
 - (iii) Shaft seal leaks.
 - (iv) Unusual noises or vibration.
 - (v) Loss of operating speed.
 - (vi) Excessive heating of the fluid.
 - (vii) Loss of pressure.
 - (m) All of the following for hydraulic and pneumatic valves:
 - (i) Cracks in the valve housing.
 - (ii) Improper return of the spool to the neutral position.
 - (iii) Leaks at spools or joints.
 - (iv) Sticking spools.
 - (v) Proper relief valve pressures as specified by the manufacturer.
 - (n) All of the following for hydraulic and pneumatic cylinders:
 - (i) Drifting caused by fluid leaking past the piston.
 - (ii) Rod seals leaking.
 - (iii) Leaks at welded joints.
 - (iv) Scored, nicked, or dented piston rods.
 - (v) Dented case (barrel).
 - (vi) Loose or deformed rod end or connecting joints.
 - (o) Evidence of rubber particles or metal chips on the filter elements of hydraulic filters.
- (8) Complete inspections of a derrick shall be performed periodically or, depending upon the derrick's activity, severity of service, and environment, at closer intervals, as specified in subrules (2) and (8) of this rule. A periodic inspection shall include all of the inspection requirements set forth in subrule (3) of this rule and an inspection of all of the following items:
- (a) Structural members for deformation, cracks, and corrosion.
 - (b) Bolts or rivets for tightness.
 - (c) All of the following for wear, cracks, and distortion:
 - (i) Pins.
 - (ii) Bearings.
 - (iii) Shafts.
 - (iv) Gears.
 - (v) Sheaves.
 - (vi) Drums.
 - (vii) Rollers.
 - (viii) Locking and clamping devices.
 - (d) Gudgeon pins for cracks, wear, and distortion.
 - (e) Derrick hooks for cracks or distortion.
 - (9) A crane or derrick that has been idle for a period of 1 month or more, but less than 6 months, shall be given an inspection that is in compliance with the requirements of subrule (3) of this rule before being placed in service.
 - (10) A crane, derrick, or excavation equipment that has been idle for a period of more than 6 months shall be given a complete inspection that is in compliance with the requirements of subrule (7) or (8) of this rule before being placed in service. Excavation equipment that has been idle for a period of 1 month or more, but less than 6 months, shall be inspected in compliance with the requirements of subrule (3) before being laced in service.

R 408.41013a Wire rope inspection.

Rule 1013a. (1) A running wire rope that is in continuous service shall be visually inspected once each working day. A visual inspection shall consist of observing all rope that can be expected to be in use during the day's operations. The purpose of the visual observations shall be to discover any of the following damage that may be an immediate hazard:

- (a) Any distortion of the rope, including any of the following:
 - (i) Kinking.
 - (ii) Crushing.
 - (iii) Unstranding.
 - (iv) Birdcaging.
 - (v) Main strand displacement.
 - (vi) Core protrusion.
- (b) General corrosion.
- (c) Broken or cut strands.
- (d) Number, distribution, and type of visible broken wires. When damage is discovered, the rope shall either be removed from service or given an inspection pursuant to the provisions of R 408.41033a.
- (e) Damage to flange points, crossover points, and repetitive pickup points on drums.

(2) The periodic inspection frequency of wire rope shall be determined by a qualified person and shall be based on all of the following factors:

- (a) Expected rope life as determined through experience on the particular installation or similar installations.
- (b) Severity of the environment.
- (c) Percentage of capacity lifts.
- (d) Frequency rates of operation.
- (e) Exposure to shock loads. Inspections need not be at equal calendar intervals and shall be more frequent as the rope approaches the end of its useful life.

(3) A wire rope that is used on a crane, derrick, or excavation equipment shall be replaced or repaired pursuant to the provisions of R 408.41033a.

R 408.41014a Marking rated capacity.

Rule 1014a. (1) An employer shall ensure that a durable and legible rating chart is at the operation station for all cranes or derricks. The chart shall show all of the following information:

- (a) Load capacity relating to operating radii for all boom lengths, jib lengths, and angles. Where outriggers or extra counterweights are provided by the manufacturer, alternate ratings shall be provided.
- (b) Any structural change that limits the ratings.
- (c) The required parts of the line for hoist reeving and the size and construction of the rope. The information specified in this subdivision is not required to be posted if it is shown in the operating manual.
- (d) Essential precautionary or warning notes relative to limitations on equipment and operating procedures.

(2) In addition to the requirements of subrule (1) of this rule, where remote control stations are used to operate a hammerhead tower crane, the employer shall ensure that a durable and legible rating chart is available at each remote control station.

(3) A crane or a derrick that has a variable angle boom shall be equipped with a boom angle indicator readily visible to the operator.

R 408.41015a Work platforms generally.

Rule 1015a. (1) A work platform that is suspended from a crane or derrick may be used to hoist or suspend personnel or to provide access in unique situations if use of the platform

is accomplished in a manner that exposes employees to the least hazard practicable.

(2) A work platform shall be in compliance with all of the following requirements:

- (a) Be designed and constructed by qualified personnel who are designated by, and responsible to, the employer and who, because of extensive knowledge, training, and experience, have successfully demonstrated their ability to solve or resolve problems relating to the subject matter, the work, or the project.
- (b) A welder who welds work platforms shall comply with the requirements of the American Welding Society (AWS) standards AWS standard IHS AWSC "Structural Welding Code," 2000 edition, AWS standard D14.1 "Welding of Industrial and Mill Cranes and Other Material Handling Equipment," 1997 edition, AWS standard B1.10 "Guide for the Nondestructive Inspection of Welds," 1986 edition, and AWS standard D14.4 "Class and Application of Welded Joints for Machinery Equipment," 1997 edition. The standards specified in this rule are adopted by reference. They are available from the Global Engineering Documents, 15 Inverness Way East, Englewood, Colorado, United States, 80112, Web-site: WWW.GLOBAL.IHS.COM, at a cost as of the time of adoption of these rules of \$438.00, \$68.00, \$84.00, and \$73.00 respectively; or for review at the Michigan Department of Consumer and Industry Services, Standards Division, 7150 Harris Drive, Lansing, Michigan 48909.
- (c) Except for the guardrail system as specified in construction safety standard Part 45. "Fall Protection," being R 408.44501 et seq. of the Michigan Administrative Code, be of welded mild steel construction that has a minimum safety factor of 5 times the maximum intended load.
- (d) Have a continuous guardrail system constructed as follows:
 - (i) Have a top rail which is located not less than 39 inches, nor more than 45 inches, above the platform floor and which is constructed to withstand a minimum of 5,000 pounds of force in any direction. A grab rail shall be installed inside the entire perimeter of the platform.
 - (ii) Have a midrail which is installed at mid-height between the top rail and platform floor and which is constructed to withstand a 200-pound side thrust.
 - (iii) Have a toeboard which is not less than 4 inches in nominal height and which is installed not more than 1/4 of an inch above the floor around the periphery of the work platform and have a steel grating which is either solid construction or expanded metal that does not have openings of more than 1/2 inch (1.27 cm) and which is installed between the floor and, at a minimum, the midrail. If the platform has a gate, the toeboard and steel grating shall be installed on the gate.
- (e) Have wood planking, steel plate, or steel grating bolted or welded to the bottom of the platform and be maintained free of slip or trip hazards.
- (f) Loadlines shall be capable of supporting, without failure, not less than 7 times the maximum intended load, except that where rotation resistant rope is used, the lines shall be capable of supporting, without failure, not less than 10 times the maximum

intended load. The required design factor is achieved by taking the current safety factor of 3.5 as required under R 408.41005a(2) and applying the 50% derating of the crane capacity that is required in R 408.41015a(2)(m). If rotation resistant wire rope is used to hoist employees, then the employer shall ensure that the wire rope is inspected by a qualified person and a record is maintained on the crane. The record shall contain all of the following information:

- (i) The size, type, and manufacturer of the wire rope.
 - (ii) The date the wire rope was inspected as required by R 408.41013a(1) and the condition at the time of inspection.
 - (iii) The name of the person who inspected the wire rope.
- (g) Have an independent 4-point suspension system that has a minimum safety factor of 5 times the intended load. Each leg shall be suspended at a maximum 45-degree angle from vertical toward the center using a minimum 1/2-inch diameter wire rope that has swedge fittings on each end. The wire rope shall be capable of maintaining the platform in a level position regardless of load placement. Wire rope clips are prohibited.
- (h) Have the independent 4-point suspension system attached to the platform using alloy anchor-type shackles with a bolt, nut, and a retaining pin or an equivalent. The suspension system shall not be used for any other purpose.
- (i) Have the suspension system connected to the load line by an alloy anchor-type shackle with a bolt, nut and retaining pin, a safety hook, or equivalent. Both ends of a minimum 5/8-inch wire rope safety line shall be installed above the headache ball to the shackle and pass through the eyes of the work platform suspension system to prevent the platform from falling if disengaged from the safety hook. If a shackle is used instead of a safety hook, then the 5/8-inch wire rope safety line is not required.
- (j) Have overhead protection where there is an overhead hazard. The employer shall ensure that there is sufficient headroom to allow employees to stand upright on the platform.
- (k) Have a permanently affixed sign that specifies all of the following information:
- (i) Maximum number of passengers.
 - (ii) Work platform identification number.
 - (iii) Maximum rated load.
 - (iv) Weight of the platform.
- (l) Be easily identifiable by high-visibility color or marking.
- (m) The total weight of the loaded personnel platform and related rigging shall not be more than 50% of the rated capacity for the radius and configuration of the crane or derrick.
- (3) The employer shall ensure that the gate only opens inward to permit employee egress from, and access to, the work platform.
- (4) A platform gate shall be securely fastened during all travel and shall only be opened during egress from, or access to, the work platform. The platform shall be used only for positioning employees at otherwise inaccessible locations to perform work and shall not be used as an elevator.

(5) The employer shall ensure that all rough edges exposed to contact by employees are surfaced or smoothed to prevent injury to employees from puncture or lacerations.

R 408.41016a Work platforms; load test requirements; trial lift; inspections; proof testing.

Rule 1016a. (1) Before a work platform is used after fabrication, it shall be load-tested to 2 times the maximum intended load (rated capacity).

- (2) A work platform shall also be load-tested as follows:
 - (a) Annually, if used on a regular basis.
 - (b) Before use, if the interval of time between use is more than 1 year.
 - (c) After the crane or work platform has been moved to another location on the jobsite.
- (3) A load test shall follow the maximum intended lift of the work platform.
- (4) The total platform load shall be not more than 50% of the rated capacity of the lifting equipment.
- (5) After any repair or modification, a platform shall be retested to 2 times its rated capacity.
- (6) A record of the load test shall be maintained by the employer for the life of the platform.
- (7) A trial lift of an unoccupied personnel platform that is loaded at least to the anticipated lift weight shall be made from ground level, or any other location where employees will enter the platform, to each location to which the personnel platform is to be hoisted and positioned. The trial lift shall be performed immediately before placing personnel on the platform. The operator shall determine that all systems, controls and safety devices are activated and functioning properly, that interferences do not exist, and that all configurations necessary to reach the work locations will allow the operator to remain under the 50% limit of the hoist's rated capacity. Materials and tools to be used during the actual lift can be loaded in the platform as provided in R 408.41018a(10) for the trial lift. A single trial lift may be performed at one time for all locations that are to be reached from a single setup position.
- (8) The trial lift shall be repeated before hoisting employees when the crane or derrick is moved and set up in a new location or returned to a previously used location. The trial lift shall be repeated when the lift route is changed, unless the operator determines that the route change is not significant and the route change would not affect the safety of hoisted employees.
- (9) After the trial lift, and just before hoisting personnel, the platform shall be hoisted a few inches and inspected to ensure that it is secure and properly balanced. Employees shall not be hoisted unless all of the following provisions are complied with:
 - (a) Hoist ropes are free of kinks.
 - (b) Multiple part lines are not twisted around each other.
 - (c) The primary attachment is centered over the platform.
 - (d) The hoisting system shall be inspected if the load rope is slack to ensure that all ropes are properly seated on drums and in sheaves.
- (10) A visual inspection of the crane or derrick, rigging, personnel platform, and the crane or derrick base support or ground shall be conducted by a competent person immediately after the trial lift to determine whether the testing has exposed a defect or produced an adverse effect upon a component or structure.
- (11) A defect that is found during an inspection that creates a safety hazard shall be corrected before hoisting personnel.

(12) At each jobsite, before hoisting employees on the personnel platform and after any repair or modification, the platform and rigging shall be proof tested, as required in subrule (1) of this rule, to the platform's rated capacity by holding it in a suspended position for 5 minutes with the test load evenly distributed on the platform proof testing may be done concurrently with the trial lift. After proof testing, a competent person shall inspect the platform and rigging. If a deficiency is found, it shall be corrected and another proof test shall be conducted. Personnel hoisting shall not be conducted until the proof testing requirements are satisfied.

R 408.41017a Work platforms; communication requirements.

Rule 1017a. (1) There shall be a communication system between employees on the work platform and the operator of the crane or derrick. The system may be hand signals, a telephone wire system, or a closed 2-way selective frequency radio system.

(2) If hand signals are being employed and employees are being raised, lowered, or positioned and are not in continuous sight of the operator of the crane or derrick at all times, then an employer shall designate an employee who is not on the work platform to be the signalperson. The signalperson shall not be assigned any other duties while the work platform is in a suspended position with employees on it. The signalperson shall remain in a position so that both the work platform and the crane or derrick operator can be seen at all times.

R 408.41018a Work platforms; safety equipment; travel rate; crane operator; platform load; arc welding; crane operation; adverse weather conditions; leaving suspended platform.

Rule 1018a. (1) An employer shall provide an employee on a work platform with, and require them to use, the proper safety equipment as prescribed by construction safety standard Part 45. "Fall Protection," being R 408.44501 et seq. of the Michigan Administrative Code. Each employee shall wear a safety belt that has a lanyard affixed to the safety belt and the top rail of the steel guardrail system of the work platform. Standing on the guardrail system is prohibited.

(2) The maximum rate of travel of a work platform shall be 100 feet per minute. Free-spooling is prohibited when using the platform to lower personnel.

(3) The operator of the crane shall remain at the controls with the engine running when an occupied work platform is in the suspended position.

(4) Load and boom hoist drum brakes, swing brakes, and locking devices, such as pawls or dogs, shall be engaged when the occupied personnel platform is in a stationary working position.

(5) Communications, as required by the provisions of R 408.41017, shall be used as a safety precaution against allowing the headache ball or load blocks to come in contact with the boom tip sheave (2-blocking).

(6) An operator of a crane that is used to raise or lower a work platform shall be authorized by the employer and be properly qualified to perform the operation.

(7) An operator of a crane shall not be authorized to raise or lower a work platform unless the operator has had not less than 8 hours of experience in the operation of the specific crane or a crane of the same type and design.

(8) The employer shall hold a pre-lift meeting to review the appropriate requirements and procedures to be followed. The meeting shall be held before the trial lift at each new work location and shall be repeated for any employees who are newly assigned to the operation.

(9) All of the following entities shall attend the prelift meeting:

- (a) The crane operator.
- (b) The signalperson, if necessary for the lift.
- (c) Employees to be lifted.
- (d) The person who is responsible for the task to be performed.

(10) The only tools that are permitted on the work platform shall be hand tools and portable powered tools. Materials and tools shall be secured to prevent displacement and shall be evenly distributed within the confines of the platform while the platform is suspended. The total weight of compressed gas containers shall not be more than 20 pounds. Employees shall not use a work platform to transport bulk material. The total load shall not be more than the rated capacity of the work platform.

(11) If arc welding is done by an employee on the work platform, the electrode holders shall be protected from contact with metal components of the work platform.

(12) When a crane is being used to raise or lower persons on a work platform, another load shall not be attached to the work platform and another load shall not be raised or lowered at the same time by the same crane.

(13) The employer shall not permit a work platform to be used during high winds, electrical storms, snow, ice, sleet, or other adverse weather conditions that could affect the safety of the employees on the work platform or the operator of the crane.

(14) A crane or derrick that is used to raise or lower a work platform shall not be used under energized power transmission and distribution lines or within 10 feet, horizontally, at the closest point of travel from a power line as specified in table 1.

(15) Only a crane that is equipped with a boom that has a power control lowering system shall be allowed to raise or lower a work platform.

(16) The load line of a crane that is used to raise or lower a work platform shall be equipped with a swivel to reduce the wire rope-induced rotation of the work platform, unless the use of the swivel is not recommended by the wire rope manufacturer.

(17) Neither the work platform nor the crane boom shall be lowered below the point where less than 3 full wraps of rope remain on their respective drums.

(18) A crane that is used to raise or lower a work platform shall be set level on a firm base and shall have the travel lock engaged.

(19) The crane shall not travel in any direction when personnel are on the work platform.

(20) A crane that is equipped with outriggers shall have the beams and jacks fully extended to provide maximum stability and the floats shall have a stable bearing when the work platform is in use.

(21) Except for a structural steel connector or a pile driver, an employee shall not leave the suspended work platform. If a structural steel connector or a pile driver leaves the suspended platform, a gate shall be provided as prescribed in R 408.41015a(3) and (4). The gate shall be in compliance with the requirements of Part 45. "Fall Protection," being R 408.44501 et seq. of the Michigan Administrative Code. The gate shall be securely fastened during all travel and opened only during access to, or egress from, the work platform.

(22) An employee shall keep all parts of his or her body inside the platform during raising, lowering, or positioning.

(23) An employer shall ensure the use of a positive acting device to prevent contact between the load block or overhaul ball and the boom tip (anti-2-blocking device) or a system that shall be used to deactivate the hoisting action before damage occurs in the event of a 2-blocking situation (2 block damage prevention feature). The load line hoist drum shall have a system or device on the powertrain, other

than the load hoist brake, that regulates the lowering rate of the speed of the hoist mechanism (controlled load lowering). Free-fall is prohibited.

(24) An employer shall ensure that a crane that has a telescoping boom is equipped with a device to indicate clearly to the operator, at all times, the boom's extended length or shall ensure that an accurate determination of the load radius to be used during the lift is made before hoisting personnel.

R 408.41019a Work platforms; use of derricks.

Rule 1019a. (1) A work platform that is raised or lowered by a derrick shall be limited to a capacity of 2 persons.

(2) All sheaves and blocks used to raise or lower a work platform by a derrick shall be not less than 18 times the diameter of the wire rope and be closed faced.

R 408.41020a Work platforms; derrick hoist machine requirements.

Rule 1020a. (1) A derrick hoist machine shall be in compliance with the provisions of ASME standard B30.7 "Base-mounted Drum Hoists," 1994 edition and be inspected on the jobsite by the employer to assure compliance. A record of the inspection shall be available on the jobsite.

(2) A derrick hoist machine shall have full power for raising and lowering the work platform. Free-spooling is prohibited.

(3) The controls of a derrick hoist machine shall be deadman controls that will return the machine to neutral and engage the drum brakes.

(4) A derrick hoist machine shall be positioned so that the distance between the drum and foot block will allow proper spooling of wire rope.

(5) A derrick hoist machine base shall be properly aligned and anchored on 4 corners to prevent movement. A 3 or 4 drum-hoist may be anchored by only the two rear corners of the base when the cables from the drums extend horizontally to the foot block, and the anchors are designed by a registered professional engineer, to resist all cable loads applied to the hoist.

(6) The foot block of a derrick hoist machine shall be anchored to prevent displacement and be supported to maintain proper alignment.

(7) All wire rope running lines shall be guarded from the drum of the hoist to the foot block and vertically where accidental contact is possible.

(8) A proper fleet angle shall be maintained between the foot block and the drum of the base-mounted drum hoist.

(9) The employer shall ensure that a hoist house for a derrick hoist machine has a roof to protect the operator from falling objects and is enclosed to protect the operator from the weather.

R 408.41021a Work platform and headache ball use generally.

Rule 1021a. (1) Before starting a project where a crane or derrick will be used to elevate or lower employees in a work platform or on the headache ball, an employer shall inspect the crane or derrick and wire rope to assure compliance with the provisions of this part immediately before allowing employees to be transported.

(2) Any structural or functional defect that could adversely affect the safe operation of a crane or derrick shall be corrected before beginning an operation with a work platform.

(3) An operator of a crane or derrick shall remain at the controls when an employee is in a suspended position.

(4) The maximum rate of travel of a work platform or headache ball shall be 100 feet per minute. Free-spooling is prohibited when a crane or derrick is used to lower personnel.

(5) An operator of a crane or derrick that is used to transport employees shall be designated by the employer and be properly qualified to perform the operation. Only a designated operator shall be permitted to operate a crane or derrick that is used to transport employees.

(6) Neither the load nor the boom shall be lowered below the point where less than 3 full wraps of wire rope remain on their respective drums.

(7) The crane or derrick shall be in a level position. The crane shall not travel in any direction when an employee is in a suspended position.

(8) A crane that is equipped with outriggers shall have the beams and jacks fully extended to provide maximum stability consistent with the manufacturer's recommendations and shall have the floats on a stable bearing.

(9) When a crane or derrick is being used to raise or lower employees, another load shall not be attached to the load line or work platform.

(10) An employee shall not be permitted to be transported in a work platform or on a headache ball during high winds, electrical storms, snow, ice, sleet, or other adverse weather conditions that could affect the safety of the employee.

(11) A crane or derrick shall not be used under energized power transmission and distribution lines or within 10 feet, horizontally, at the closest point of travel from a power transmission or distribution line when raising or lowering employees.

R 408.41022a Headache ball; use by certain employees; signalperson.

Rule 1022a. (1) Structural steel connectors are permitted to use a headache ball as provided in construction safety standard Part 26. Steel and Precast Erection, being R 408.42601 et seq. of the Michigan Administrative Code.

(2) If an employee who is being transported on a headache ball is not in constant view of the operator (operating in the blind), a signalperson shall be assigned to give required signals to the operator. The signalperson shall not be assigned any other duties while the employee on a headache ball is in a suspended position and shall remain in a position so that both the employee on the headache ball and the operator of the crane or derrick can be seen at all times.

R 408.41023a Energized parts clearances; grounding and notification.

Rule 1023a. (1) A crane, derrick, or excavation equipment shall not be operated closer to an exposed energized part than the clearances prescribed in table 1, unless adequate clearances cannot be maintained.

(2) If an adequate clearance cannot be maintained, then an employer shall notify the owner of the energized part and shall comply with either of the following provisions:

(a) An insulated barrier shall be installed on the exposed energized part.

(b) The energized part shall be de-energized and grounded.

(3) An employee who works with a load line or a load that is attached to a load line which is connected to equipment within the clearance distance prescribed in table 1 shall be provided with, and shall wear, personal protective equipment as prescribed in construction safety standard Part 16. "Power Transmission and Distribution," being R 408.41601 et seq. of the Michigan Administrative Code.

(4) Material stored near an electrical distribution or transmission line shall not be closer to the line than the following distances:

- (a) For a line that is rated 50 kilovolts (kV) or less - 10 feet plus the length of the material stored.
- (b) For a line that is rated 50 kilovolts (kV) or more - 10 feet plus 0.4 inch for each 1 kilovolt (kV) over 50 plus the length of the material stored. (See Part 8 "Handling and Storage of Materials," being R 408.41081 et seq. of the Michigan Administrative Code).

(5) An overhead line or equipment shall be considered to be energized until the owner or utility indicates otherwise.

(6) Table 1 reads as follows:

TABLE 1		
Voltage	Boom Raised	Clearance Boom Lowered and No Load
to 50 kV	10 feet	4 feet
50 to 345 kV	10 feet + 0.4 inch per kV over 50 kV	10 feet
346 to 750 kV	10 feet + 0.4 inch per kV over 50 kV	16 feet

(7) A person shall be designated by the employer to observe the clearance of the equipment and give timely warning for all operations where it is difficult for the operator to maintain the desired clearance by visual means.

(8) Before work near transmitter towers where an electrical charge can be induced in the equipment or materials being handled, the employer shall ensure that the transmitter is de-energized or tests shall be made to determine if electrical charge is induced on the crane. The employer shall ensure that all of the following precautions are taken when necessary to dissipate induced voltages:

- (a) The equipment shall be provided with an electrical ground directly to the upper rotating structure supporting the boom.
- (b) Ground jumper cables shall be attached to materials being handled by boom equipment when an electrical charge is induced while working near energized transmitters. Crews shall be provided with nonconductive poles having large alligator clips or other similar protection to attach the ground cable to the load.
- (c) Combustible and flammable materials shall be removed from the immediate area before operations.

R 408.41024a Swing radius clearance.

Rule 1024a.(1) Accessible areas within the swing radius of the rear of the rotating superstructure of the crane, either permanently or temporarily mounted, shall be barricaded in a manner that prevents an employee from being struck or crushed by the crane.

(2) If a clearance of 30 inches cannot be maintained between the rotating or moving structure of a stationary crane or derrick or other similar lifting equipment and any other obstruction, and if an employee could be struck by the rotating or moving structure, the hazardous area shall be barricaded to prevent an employee from being struck.

(3) If clearances between the rotating or moving structure of a constantly moving crane or derrick can create a pinch point for an employee or if an employee could be struck by the rotating or moving structure, an employer, in place of the barricades, shall train and instruct each employee to stay out of the danger area and a danger sign, as prescribed in construction safety standard Part 22. Signals, Signs, Tags, and Barricades, being R 408.42201 et seq. of the Michigan Administrative code, shall be affixed to the rear and sides of the house and counterweight. The additional lettering on the danger sign shall indicate that the counterweight is swinging.

(4) If an employee could be struck by the rotating superstructure of excavation equipment, the hazardous area shall be barricaded to prevent an employee from entering and being struck.

(5) If clearances between the rotating or moving structure of constantly moving excavation equipment can create a pinch point for an employee, or if an employee could be struck by the rotating superstructure, an employer, in place of barricades, shall train and instruct each employee to stay out of the danger area and a danger sign, as prescribed in construction safety standard Part 22. Signals, Signs, Tags, and Barricades, being R 408.42201 et seq. of the Michigan Administrative Code, shall be affixed to the rear and sides of the house and counterweight. The additional lettering on the danger sign shall indicate that the counterweight is swinging.

R 408.41025a Crane, derrick, and excavating equipment; operating rules generally.

Rule 1025a. (1) An operator shall not leave a crane, derrick, or excavation equipment unattended with a load suspended above the ground, floor, or platform during working operations. A bucket or blade shall not be left suspended above the ground when a machine is unattended.

(2) The provisions of subrule (1) of this rule do not prohibit leaving job-related equipment hanging on the hook to prevent theft or vandalism during the hours the project is shut down.

(3) A load in an elevated position shall not be detached from the load line of a crane, derrick, or excavation equipment until the load has been secured to prevent unintentional movement.

(4) The employer shall ensure that exhaust piping which is in close proximity to an employee during the normal course of operation and which would cause a burn on contact is insulated or guarded.

(5) Windows of any crane, derrick, or excavation equipment shall be equipped with safety glass or its equivalent. Visual distortions which are caused by broken or defective glass and which would affect the safe operation of the equipment when in use shall be corrected.

(6) A fuel tank filler pipe for an internal combustion engine that powers a crane or derrick shall be located or guarded to prevent the spillage of fuel onto a hot surface or electrical equipment.

(7) Where necessary for rigging or servicing, a ladder or steps shall be provided to give access to a cab roof.

(8) Handholds and steps shall be provided on all lifting and digging equipment for access to the cab. Platforms and walkways shall have slip-resistant surfaces, and guardrails as prescribed in construction safety standards Part 21. "Guarding of Walking and Working Areas," being R 408.42101 et seq. and Part 45. "Fall Protection," being R 408.44501 et seq. of the Michigan Administrative Code.

(9) Fuels shall be transported, stored, and handled as prescribed in construction safety standard Part 18. "Fire Protection and Prevention," being R 408.41801 et seq. of the Michigan Administrative Code.

(10) A load line shall not be wrapped around the material being lifted.

(11) Before starting to hoist, an operator shall do all of the following:

- (a) Make sure the hoist rope is not kinked.
- (b) Make sure the multiple part lines are not twisted around each other.
- (c) Make sure the hook is not swinging when brought over the load.

(12) An employee shall not be permitted under a suspended load.

(13) A crane, derrick, or excavation equipment shall not be loaded beyond the rated load.

(14) When loads that are limited by hydraulic or structural competence rather than by stability are to be handled, the person who is responsible for the job shall ascertain that the weight of a load approaching rated capacity has been determined and does not exceed the capacity of the equipment.

(15) In moving a load, an operator shall avoid sudden acceleration or deceleration of a moving boom that would cause a swinging action by the load.

(16) A load shall be secured and balanced before the load is lifted more than 6 inches.

(17) An operator shall test the hoisting brakes before moving a near maximum rated load by raising the load a few inches and applying the hoisting brakes. This requirement applies to both single and multiple line reeving.

(18) A load or boom shall not be lowered below a point where less than 2 full wraps of rope remain on the drum at its lowest point.

(19) A load shall not be moved in a manner that could contact obstructions.

(20) If there is a slack rope condition, it shall be determined that the rope is properly seated and tight on the drum and in the sheaves before hoisting.

(21) The rotational speed of a crane, derrick, or excavation equipment shall be such that the center of the load does not swing out beyond the radius of the point sheave in use. A tag line shall be used when rotation of the load would be hazardous.

(22) A crane, derrick boom, or excavation equipment shall not be used for dragging a load sideways.

(23) Floats or pads that are secured to outriggers shall be used when the load to be handled at a particular radius is more than the rated load without outriggers. A wood block that is used to support an outrigger shall be in compliance with all of the following provisions:

- (a) Be of a size that prevents shifting and tipping of the load.
- (b) Be strong enough to resist crushing.
- (c) Be free of defects that could affect its ability to support the load.

(24) Before moving a crane or excavation equipment that is carrying a load, an on-site supervisor or an operator, or both, shall determine all of the following:

- (a) The position to carry the load.
- (b) The boom location.
- (c) The ground conditions.
- (d) The travel route.
- (e) The speed of movement.
- (f) The location of overhead wires.

(25) While being moved from one jobsite to another, a crane or excavation equipment shall be in compliance with both of the following provisions:

- (a) The boom shall be carried in line with the direction of movement.
- (b) The superstructure shall be secured against rotation, except when negotiating a turn with an operator in the cab or the boom on a dolly.

(26) A crane or excavation equipment shall not travel with the boom at a height that could allow the boom to bounce back over the cab.

(27) Any crane or excavation equipment that is not equipped with a boom which has a power control lowering system (live boom) shall have the boom positively locked (dogged) to prevent lowering when personnel are working under the boom.

(28) For moving loads with multiple cranes or multiple pieces of excavation equipment, the requirements of subrule (24) of this rule shall be complied with. Additionally, the load, conditions, and equipment capacities shall be analyzed and a plan of operation shall be formulated.

(29) Clothing, personal belongings, tools, and other articles within a cab or operating enclosure shall be stored in cabinets, boxes, or by other means so as not to interfere with access or operations.

(30) A portable fire extinguisher that has a rating of not less than 10 BC, shall be kept in the cab or operating enclosure or where there is no cab or enclosure, shall be kept on the jobsite within a 200-foot radius of the equipment and shall be readily available. The operator and maintenance employees shall be trained in the use of the fire extinguisher.

(31) Where night operations are carried out, lighting shall illuminate the immediate working area to a minimum of 10 footcandles and shall not interfere with the operator's vision.

(32) A rope shall not be handled on a winch head without the knowledge of the operator.

(33) A rope shall not be used to carry current or as a ground on any crane or derrick.

(34) An employee shall not ride the bare hook or on a load of material suspended from the hook.

R 408.41025 Rescinded.

R 408.41026 Rescinded.

R 408.41027 Rescinded.

R 408.41028 Rescinded.

R 408.41030 Rescinded.

R 408.41031 Rescinded.

R 408.41026a Locomotive and truck cranes; lifting restrictions.

Rule 1026a. (1) Before lifting a load with a locomotive crane without outriggers, a means shall be provided to prevent carrying the load on the truck springs. Rail clamps shall not be used to restrain a locomotive crane from tipping.

(2) A load shall not be lifted over the front area of a truck crane unless it is within the capacity of the rating chart for the front area of the truck crane.

R 408.41027a Mobile hydraulic crane; operating requirement.

Rule 1027a. When using a mobile hydraulic crane that has a powered telescoping boom, an operator shall take care to prevent two-blocking.

R 408.41028a Hammerhead tower crane; operating requirement.

Rule 1028a. (1) Before leaving a hammerhead tower crane unattended, an operator shall, in addition to the requirements specified in R 408.41010a(3), do all of the following:

- (a) Set the trolley brakes and other locking devices and bring the hook block to its highest position.

- (b) Secure the crane to prevent accidental travel.
- (c) Set rail clamps, where provided.
- (d) Release the swing brake to allow weathervaning, unless a 360-degree rotation is not possible. Where the crane must be restrained from swinging freely, the manufacturer's recommendations shall be followed.

(2) A hammerhead crane shall not be operated when wind speeds are more than the maximum velocities recommended by the manufacturer.

(3) A hammerhead crane shall not be raised to a new operating level above the structure when the wind speed is more than 20 miles per hour (32.2Km/hr.) or when the wind speed is a lower velocity if so recommended by the manufacturer.

(4) In regions where winds are gusty or velocities changeable, means shall be provided to keep a crane stable if wind velocity rises above the recommended limits for climbing operations.

(5) A crane operator shall be present during all climbing operations.

(6) Where a floor of a structure is used as the supporting base for a crane, a competent person shall determine the load bearing ability of the floor and recommend necessary shoring.

(7) Crane operation during weather conditions that produce icing of the crane structure or reduced visibility shall be undertaken only in accordance with the crane manufacturer's recommendations for such conditions.

(8) An employee who is required to perform duties on the horizontal boom of a hammerhead tower crane shall be protected against falling by guardrails or safety belts and lanyards attached to lifelines in conformance with construction safety standard Part 45. Fall Protection, being R 408.44501 et seq. of the Michigan Administrative Code.

(9) A buffer shall be provided at each end of the trolley. A crane mounted on rail tracks shall be equipped with a limit switch that limits the travel of the crane on the track and with a stop or buffer at each end of the tracks.

R 408.41029a Portal, tower, or pillar cranes; requirements for leaving crane unattended; wind speed operating restriction.

Rule 1029a. (1) Before leaving a portal, tower, or pillar crane unattended, an operator shall, in addition to the requirements specified in R 408.41010a(3), do all of the following:

- (a) Lower the boom to the boom rest or otherwise fasten it securely to prevent displacement due to wind loads or other outside forces, unless this is contrary to the manufacturer's recommendations.
- (b) Set the brakes and other locking devices and bring the hook block to its highest position.
- (c) Secure the crane to prevent accidental travel.
- (d) Set rail clamps, where provided.

(2) A portal, tower, or pillar crane shall not be operated when the wind speed is more than the speed recommended by the manufacturer.

R 408.41030a Overhead and gantry cranes; operating requirements.

Rule 1030a. (1) When starting on duty, an operator of an overhead or gantry crane shall, in addition to the requirements specified in R 408.41010a(3), comply with both of the following provisions:

- (a) Not close the main switch or emergency contactor until a check is made to see if anyone is on the crane or if a warning sign is on the crane, hook, or main switch.

- (b) Test all controls, limit switches, and brakes. When a load approaches the maximum rated load, an operator shall test the hoisting brakes by raising the load a few inches and applying the brakes.

(2) A hoisting limit switch on an overhead or gantry crane shall not be used as an operating control unless the crane is also equipped with a backup limit switch.

(3) The rated load of the crane shall be plainly marked on each side of the crane and, if the crane has more than 1 hoisting unit, each hoist shall have its rated load marked on it or its load block. The rated load marking shall be clearly legible from the ground or floor.

(4) Bridge trucks shall be equipped with sweeps that extend below the top of the rail and project in front of the truck wheels.

(5) Except for floor-operated cranes, a gong or other effective audible warning signal shall be provided for each crane that is equipped with a power traveling mechanism.

(6) All overhead and gantry cranes in use shall be in compliance with the applicable requirements for design, construction, installation, testing, maintenance, inspection, and operation as prescribed in general industry safety standard Part 18. Overhead and Gantry Cranes, being R 408.11801 et seq. of the Michigan Administrative code.

R 408.41031a Floating cranes and floating derricks; leaving crane or derrick unattended; rated load capacity of barge-mounted mobile crane; provision of load rating chart; compliance with employee protection requirements.

Rule 1031a. (1) An operator shall not leave a floating crane or derrick unattended until notified by the supervisor that it is safe to do so. Before leaving, the operator shall in addition to the requirements specified in R 408.41010a(3), do both of the following:

- (a) Lower the boom to the boom rest or otherwise fasten it securely to prevent displacement due to wind loads or other outside forces.
- (b) Engage manual locking devices in the absence of automatic holding equipment on derricks and engage swing brakes, boom brakes, and other locking devices on cranes.

(2) An operator shall engage dogs, pawls, or other positive locking mechanisms on the boom hoist.

(3) When not in use, a derrick boom shall be in compliance with 1 of the following provisions:

- (a) Be laid down.
- (b) Be secured to a stationary member, as near to under the boom head as possible, by attaching a sling to the load block.
- (c) Be hoisted to a vertical position and secured to the mast.

(4) When not in use, a crane boom shall either be lowered to the deck of the barge and secured or secured on a boom rest or boom cradle, when provided.

(5) When a mobile crane is mounted on a barge, the rated load of the crane shall not exceed the original capacity specified by the manufacturer.

(6) A load rating chart, that has clearly legible letters and figures, shall be provided with each crane and shall be securely fixed at a location that is easily visible to the operator.

(7) When load ratings are reduced to stay within the limits for list of the barge with a crane mounted on it, a new load rating chart shall be provided.

- (8) Mobile cranes on barges shall be positively secured.

(9) Cranes and derricks that are permanently installed on a barge shall have the capacity and limitations of use based on competent design criteria.

(10) Floating cranes and floating derricks in use shall be in compliance with the applicable requirements for design, construction, installation, testing, maintenance, and operation as prescribed by the manufacturer.

(11) An employer shall comply with the applicable requirements for the protection of employees who work on marine vessels specified in 29 C.F.R. §1926.605, "Marine Operations and Equipment", and in construction safety standard Part 13. "Mobile Equipment," being R 408.41301 et seq. of the Michigan Administrative Code. The standards specified in this rule are adopted by reference.

R 408.41032a Hooks and shackles.

Rule 1032a. (1) Load hooks and hook blocks shall be weighted to overhaul the line from the highest hook position.

(2) A closed hook shall be used unless the closed hook creates a hazard.

(3) A hook or shackle shall have a rated capacity equal to or greater than the load to which it is attached.

(4) A hook shall be discarded for any of the following reasons:

- (a) The throat opening is more than 15% of the manufactured size.
- (b) The hook has more than 10 degrees of twist from a vertical centerline drawn through the hook center.
- (c) Any cracks are observed.
- (5) Special custom designs, hooks, clamps, and other lifting accessories for units, such as modular panels, prefabricated structures, and similar materials, shall be marked to indicate the safe working loads and shall be proof-tested before use to 200% of their rated loads. An untested makeshift fastener shall not be used.

(6) A shackle and connecting pin and other accessories shall be discarded if the diameter of the pin is reduced by more than 10%.

R 408.41033a Wire rope generally.

Rule 1033a. (1) A wire rope that is used on a crane or derrick shall be repaired or replaced in any of the following instances:

- (a) One third or more of the original diameter of the outside individual wires is worn.
- (b) There is kinking, crushing, bird-caging, or any other damage that results in distortion of the running portion of the wire rope structure.
- (c) The wire rope shows heat or corrosive damage.
- (d) In running ropes, there are 6 randomly distributed broken wires in 1 lay or 3 broken wires on 1 strand in 1 lay. In rotation-resistant ropes, 2 randomly distributed broken wires in 6 rope diameters or 4 randomly distributed broken wires in 30 rope diameters.
- (e) There are reductions from nominal diameter of more than the following:
 - (i) One sixty-fourth of an inch for a diameter to and including 5/16 of an inch.
 - (ii) One thirty-second of an inch for a diameter 3/8 of an inch to and including 1/2 of an inch.
 - (iii) Three sixty-fourths of an inch for a diameter 9/16 of an inch to and including 3/4 of an inch.
 - (iv) One sixteenth of an inch for a diameter 7/8 of an inch to and including 1 1/8 inches.
 - (v) Three thirty-seconds of an inch for a diameter 1 1/4 inches to and including 1 1/2 inches.

(f) In standing ropes, there are more than 2 broken wires in 1 lay in sections beyond end connections or more than 1 broken wire at an end connection.

(2) The unreeling or uncoiling of wire rope shall be done as recommended by the rope manufacturer and with care to avoid kinking or inducing a twist.

(3) The defective portion of a wire rope that is removed as provided for in subrule (1) of this rule shall not be used for other load-carrying service.

(4) Wire rope for a crane or derrick that is bent to form an eye shall be equipped with a metal thimble.

(5) Wire rope that has an independent wire rope core shall be used on all molten metal applications and where the environmental atmosphere in which the rope is used will cause deterioration of a hemp center.

(6) Wire rope shall be stored in a manner to prevent damage or deterioration.

R 408.41051a Inspections generally, excavation equipment.

Rule 1051a. (1) A thorough, annual inspection of all boom equipped excavating equipment shall be made by a qualified person. An employer shall maintain, on the jobsite or attached to the equipment, a copy of the latest equipment inspection record with the date and results for each piece of equipment.

(2) The inspection procedure for excavation equipment in regular service is divided into 2 general classifications based upon the intervals an inspection should be performed. The intervals in turn are dependent upon the nature of the critical components of the excavating equipment and the degree of their exposure to wear, deterioration, or malfunction. The 2 general classifications are designated in these rules as "frequent" and "periodic," with respective intervals between inspections as follows:

- (a) Frequent inspection – daily to monthly intervals.
- (b) Periodic inspection – 1 to 12-month intervals, or as specifically recommended by the manufacturer.

(3) All of the following items on all boom-equipped excavation equipment shall be inspected at frequent intervals:

- (a) All control mechanisms shall be inspected daily for maladjustment that interferes with proper operation.
- (b) All control mechanisms shall be inspected daily for excessive wear of components and contamination by lubricants or other foreign matter.
- (c) All boom chords and lacing shall be visually inspected daily.

MATERIAL AND PERSONNEL HOISTS (ELEVATORS)

R 408.41065a Material and personnel hoists generally.

Rule 1065a. (1) An employer shall ensure that an employee who is specifically engaged in installing personnel elevators or hoists is licensed by the state of Michigan in accordance with Act No. 227 of the Public Acts of 1967 and Act No. 333 of the Public Acts of 1976, being §408.801 et seq. and §338.2151 et seq., respectively, of the Michigan Compiled Laws, and the rules of the department of consumer and industry services relating to elevators.

(2) An employer shall comply with the manufacturer's specifications and limitations applicable to the operation of all material and personnel hoists. If the manufacturer's specifications are not available, then the limitations assigned to the equipment shall be determined by a qualified person who is competent in the field and shall be based on the requirements of ANSI A10.4 "Safety Requirements for Personal Hoists and Employee Elevators for Construction and Demolition Operations," 1990 edition and ANSI A10.5

“Safety Requirements for Material Hoists,” 1992 edition. A determination shall be documented and recorded. Attachments used shall not exceed the capacity, rating, or scope recommended by the manufacturer.

(3) The employer shall ensure that rated load capacities, recommended operating speeds, and special hazard warnings or instructions shall be posted on cars and platforms.

R 408.41066a Employer responsibility.

Rule 1066a. (1) An employer shall limit the operation of material and personnel hoists to the following entities:

- (a) An employee who has been trained and qualified to operate the hoisting equipment to which the employee is assigned.
- (b) Authorized maintenance personnel when performing their duties.

(2) An employer shall maintain hoisting equipment and accessories in a condition that will not endanger an operator or other employees.

(3) When modifications or changes to personnel hoists are made, the capacity, operation, and maintenance instruction plates, tags, or decals shall be changed accordingly. The original safety factor of the equipment shall not be reduced.

(4) An employer shall comply with all applicable requirements of this part.

R 408.41067a Employee responsibility.

Rule 1067a. (1) An operator shall report any recognized defects of any material and personnel hoisting equipment to the supervisor.

(2) An employee shall not alter or bypass any safety device.

R 408.41068a Operator training.

Rule 1068a. Before assignment, an employer shall assure that an operator of a material and personnel hoist has been trained in all of the following areas:

- (a) The capabilities of the equipment.
- (b) The purpose, use, and limitations of the controls.
- (c) How to conduct daily inspections.
- (d) Operational practices of the assigned equipment through its functions necessary to perform the required job.
- (e) Applicable state standards and company rules and regulations.

R 408.41069a Operator conduct.

Rule 1069a. (1) An operator shall not engage in any practice that will divert his or her attention while engaged in operating a material or personnel hoist.

(2) Each operator shall be responsible for those operations under the operator's direct control. When there is any doubt as to safety, the operator shall stop operations and consult with the supervisor before continuing work.

(3) An operator shall not leave the equipment unattended unless it has been secured and rendered inoperable in the operators absence.

(4) When controls are locked out for maintenance or for repair purposes, an equipment operator shall not start operations until the lock has been removed by the person or persons responsible for the safe operation.

(5) If a malfunction occurs during the operation of the equipment and the door remains locked, the operator and all other personnel shall remain in the cab until the operation is restored.

(6) An operator shall be familiar with the equipment and

its proper care. If adjustments or repairs are necessary or if any defects are evident, the operator shall report the repairs or defects to the responsible supervisor and also notify the next operator of the equipment status.

(7) A hoist operator shall ensure that the rated capacity of the hoist is not exceeded.

R 408.41070a Signals.

Rule 1070a. A signal communication system shall be provided for use between the material and personnel hoist operator and landings.

R 408.41070b Material hoists.

Rule 1070b. (1) Operating rules for material hoists shall be established and posted at the operator's station of the hoist. The rules shall include a signal system and the applicable manufacturer's specifications for rated operating speed. Rules and notices shall be posted on the car frame in a conspicuous location and shall include the statement

“NO RIDERS ALLOWED.”

A person shall not be allowed to ride on a material hoist, except for inspection and maintenance.

(2) All entrances of the hoistway shall be protected by substantial gates that shall guard the full width of the landing entrance from floor to ceiling. A hoistway entrance gate shall be identified as such.

(3) A gate that protects the entrance to a hoistway shall be equipped with a latching device and be not more than 4 inches from the edge of the landing sill. A gate shall extend a minimum of 6 feet 8 inches above the floor.

(4) Overhead protective covering of 2-inch planking, 3/4 inch plywood or other solid material of equivalent strength shall be provided on the top of every material hoist cage or platform.

(5) An operator's station of a hoisting machine shall have overhead protection equivalent to tight planking that is not less than 2 inches thick. The support for the overhead protection shall be of equal strength.

(6) A hoist tower may be used with or without enclosures on all sides. However, whichever alternative is chosen, all of the following applicable conditions shall be met:

(a) When a hoist tower is enclosed, it shall be enclosed on all sides for its entire height with a screen enclosure of not more than 1/2-inch mesh of no. 18 United States gauge wire or equivalent, except for a landing access.

(b) When a hoist tower is not enclosed, the hoist platform or car shall be totally enclosed (caged) on all sides for the full height between the floor and the overhead protective covering with 1/2-inch mesh of no. 14 United States gauge wire or equivalent. The hoist platform enclosure shall include the required gates for loading and unloading. An 8-foot high enclosure shall be provided on the unused sides of the hoist tower at ground level.

(c) In either alternative, the cab or platform shall be enclosed as specified in subdivision (b) of this subrule.

(7) A car safety device shall be installed to function in case of rope failure and shall be tested upon installation and at 4-month intervals.

(8) A material hoist tower shall be designed by a licensed professional engineer.

(9) Wire rope shall be in compliance with the requirements of R 408.41033a and shall be inspected and removed from service if any condition specified in R 408.41013a and R 408.41033a is present.

PERSONNEL HOISTS

R 408.41071a Inspections.

Rule 1071a. (1) Before being put into service, a qualified person shall inspect and test all functions of a personnel hoist. An inspection and test is required after a major alteration of an existing installation. All hoists shall be inspected and tested at not more than 90-day intervals.

(2) An employer shall prepare a certification record that includes all of the following information:

- (a) The date of the inspection and test of all functions and safety devices that were performed.
- (b) The signature of the person who performed the inspection and tests.
- (c) A serial number or other identifier for the hoist that was inspected and tested. The most recent certification record shall be maintained on file on the jobsite.

(3) A load safety test, as required by ANSI A10.4 "Safety Requirements for Personnel Hoists and Employee Elevators for Construction and Demolition Operations," 1990 edition, shall be performed on a personnel hoist by a licensed elevator contractor in the presence of a state of Michigan elevator inspector every 90 days.

(4) All control mechanisms shall be inspected daily for misadjustments that might interfere with proper operation and for excessive wear of components.

R 408.41072a Personnel hoists generally.

Rule 1072a. (1) The rated load capacities and special hazard warnings or instructions for personnel hoists shall be posted conspicuously on cars and platforms.

(2) A hoist tower outside the structure shall be enclosed for the full height on the side or sides used to enter and exit the structure. At the lowest landing, the enclosure on the sides not used to exit or enter the structure shall be enclosed to a height of not less than 10 feet. Other sides of the tower adjacent to floors or scaffold platforms shall be enclosed to a height of 10 feet above the level of the floors or scaffolds.

(3) A hoistway inside a structure shall be enclosed on all 4 sides throughout the full travel of the hoistway.

(4) A tower shall be anchored to the structure at intervals of not more than 30 feet in height. When tie-ins are not practical, the tower shall be anchored by means of guys which are made of wire rope that is not less than 1/2 of an inch in diameter and which are securely fastened to the anchorage to ensure stability.

(5) Hoistway doors or gates shall be not less than 6 feet 6 inches high, are provided with mechanical locks that cannot be operated from the landing side, and are accessible only to persons on the car.

(6) A car shall be permanently enclosed on all sides and the top, except for sides used for entry and exit and sides that have car gates or doors.

(7) A door or gate shall be provided at each entrance to the car and shall protect the full width and height of the car entrance opening.

(8) An overhead protective covering that consists of 2-inch planking, 3/4-inch plywood, or other solid material of equivalent strength shall be provided on the top of every personnel cab.

(9) Doors or gates shall have electric contacts that do not allow movement of the hoist when a door or gate is open.

(10) A car safety device shall be installed and shall be capable of stopping and holding the car and the rated load when traveling at governor-tripping speed.

(11) A car shall have a capacity and data plate secured in a conspicuous place on the car or crosshead.

(12) Normal and final terminal stopping devices shall be provided. Final terminal stopping devices shall be installed in the hoistway and shall be mechanically operated.

(13) An emergency stop switch shall be provided in the car and marked "STOP."

(14) A wire rope shall be in compliance with all of the following requirements:

- (a) Not less than 3 hoisting ropes shall be used with traction hoists.
- (b) Hoisting and counterweight wire ropes shall be not less than 1/2 of an inch in diameter.
- (c) Not less than 2 ropes shall be used for the counterweights on the rack and pinion.
- (d) Safety factors shall be as follows:

MINIMUM FACTORS OF SAFETY FOR SUSPENSION WIRE ROPES	
Rope speed in feet per minute	Minimum Factor of safety
50	7.60
75	7.75
100	7.95
125	8.10
150	8.25
175	8.40
200	8.60
225	8.75
250	8.90
300	9.20
350	9.50
400	9.75
450	10.00
500	10.25
550	10.45
600	10.70

(e) The following formula shall be used to calculate the allowable gross load:

$$L = \frac{SN}{F}$$

- L = Allowable gross load
- S = Manufacturer's rated breaking strength
- N = Number of parts of rope
- F = Safety factor

(15) All personnel hoists used by employees shall be constructed of materials and components that are in compliance with the specifications for materials, construction, safety devices, assembly, and structural integrity as stated in ANSI standard A10.4 "Safety Requirements for Personnel Hoists and Employee elevators for Construction and Demolition Operations," 1990 edition.

(16) Internal combustion engines shall not be permitted for direct drive.

R 408.41073a Bridge tower personnel hoists.

Rule 1073a. (1) A personnel hoist that is used in bridge tower construction shall be approved by a registered professional engineer and erected under the supervision of a qualified person competent in the field.

(2) When a hoist tower is not enclosed, the cab shall be totally enclosed (caged) on all sides for the full height between the floor and the overhead protective covering with not less than 3/4-inch mesh of no. 14 United States gauge wire or equivalent. The hoist car enclosure shall include the required gates for loading and unloading.

(3) A hoist shall be inspected for defects, serviced and maintained on a weekly basis, and repaired as necessary. If the hoisting equipment is exposed to winds of more than 35 miles per hour, it shall be inspected and repaired if necessary by authorized personnel before reuse.

R 408.41074a Wire rope.

Rule 1074a. Wire rope, used on personnel hoists shall be taken out of service when any of the following conditions exist:

- (a) In running ropes, where 6 randomly distributed broken wires in 1 lay or three broken wires in 1 strand in 1 lay are present.
- (b) If abrasion or wear of 1/3 of the original diameter of outside individual wires, kinking, crushing, bird-caging, or any other damage that results in distortion of the rope structure occurs.
- (c) If evidence of any heat damage or corrosion from any cause is present.
- (d) If reductions from nominal diameter of more than 3/64 of an inch for diameters to and including 3/4 of an inch, 1/16 of an inch for diameters 7/8 of an inch to 1 1/8 inches, inclusive, or 3/32 of an inch for diameters 1 1/4 to 1 1/2 inches, inclusive, are present.
- (e) In standing ropes where more than 2 broken wires in 1 lay in sections beyond end connections or more than 1 broken wire at an end connection, occur.

R 408.41075a Use of multiple permanent elevators; use of endless belt-type manlifts prohibited.

Rule 1075a. (1) When multiple permanent elevators are available and 1 elevator is being used for construction or renovation purposes, that elevator shall be for the exclusive use of construction personnel and shall be operated by a designated operator. The elevator signal system shall be separate from any other elevators.

(2) Endless belt-type manlifts shall not be used for construction.

BASE-MOUNTED DRUM HOISTS

R 408.41077a Base-mounted drum hoists.

Rule 1077a. (1) Exposed moving parts on basemounted hoists, such as gears, projecting screws, setscrews, chain, cables, chain sprockets, and reciprocating or rotating parts, shall be guarded.

(2) All controls used during the normal operating cycle shall be located within easy reach of the operator's station. Electric motor-operated hoists shall have a means to stop remotely operated hoists if the controls are ineffective.

(3) Electric motor-operated hoists shall be equipped with the following items:

- (a) A device that will disconnect all motors from the line upon power failure and that will not permit any motor to be restarted until the controller handle is brought to the "off" position.
- (b) Where applicable, an overspeed-prevention device.
- (4) All base-mounted drum hoists in use shall be in compliance with the applicable requirements for design, construction, installation, testing, inspection, maintenance, and operations as prescribed by the manufacturer and applicable ASME standard B30.7 "Base Mounted Drum Hoists," 1994 edition.
- (5) Figure 2 reads as follows:

FIGURE 2

THREE-DRUM BASE-MOUNTED HOIST

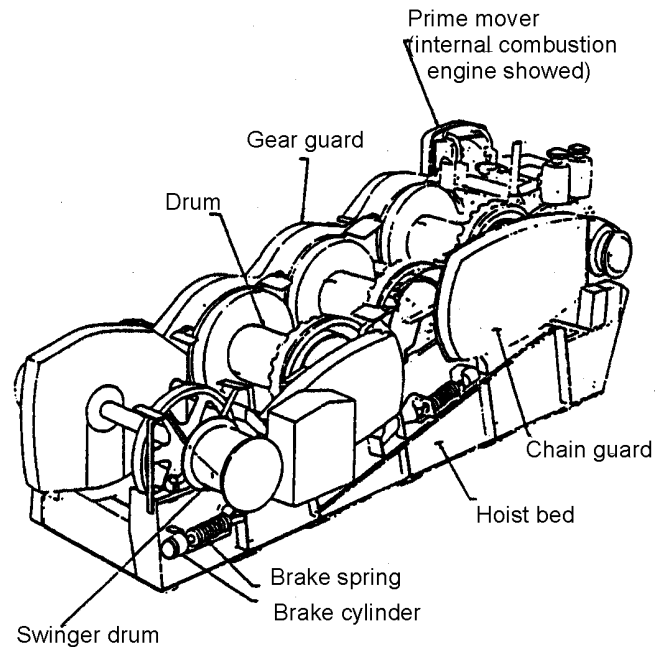

R 408.41099a Rescissions.

Rule 1099a. (1) R 408.2001 to R 408.2014 of the Michigan Administrative Code, appearing on pages 3308 to 3311 of the 1964-1965 Annual Supplement to the 1954 Michigan Administrative Code, were rescinded effective March 2, 1974.

(2) R 408.41001, R 408.41004, R 408.41024, R 408.41025, R 408.41026, R 408.41027, R 408.41028, R 408.41030, and R 408.41031 of the Michigan Administrative Code, appearing on page 4187 of the 1979 Michigan Administrative code and pages 830 to 833 of the 1985 Annual Supplement to the code, are rescinded.

APPENDIX A

Grades of Wire Used in Wire Rope

Improved plow steel wire, is made of Level 3 steel which is a strong, tough, durable steel, combining great strength with high resistance to fatigue. Its minimum tensile strength varies from 223 to 258 ksi, depending upon wire diameter.

Extra improved plow, is made of Level 4 steel. This is a high strength grade designed for use where a higher breaking strength is required. Application of this grade should be preceded by engineering consultation. Minimum tensile strength varies from 245 to 284 ksi, depending upon wire diameter.

In addition to these grades, other grades are available to meet specific requirements. Some grades are covered by wire rope standards while others may be specially tailored.

Cores – Most wire ropes are supplied either with a fiber or steel core. The core is the foundation of a wire rope. Its primary function is to support the wire strands of the rope, maintaining them in their correct relative positions during the operating life of the rope.

Fiber cores are ropes made from fibers formed into yarns, then into strands and finally into the finished core form. There are two general types of fiber: natural vegetable material, such as sisal and synthetic filaments, such as polypropylene.

Steel cores comprise an independent wire rope (IWRC) or, in the case of small diameter ropes, a wire strand core (WSC). These steel cores provide more substantial support than fiber cores to the outer strands during the rope's operating life. Steel cores resist crushing, are more resistant to heat, reduce the amount of stretch, and increase the strength of the rope.

Wire Rope Lay – The helix or spiral of the wires and strands in a rope is called the lay. Regular lay means the wires and strands spiral in opposite directions; the wires appear to run roughly parallel to the center of the rope. Lang lay is the opposite; the wires and strands spiral in the same direction and seem to run at a diagonal to the center line of the rope. If the strands rotate around the rope in a clockwise direction (as threads do in a right hand bolt), the rope is said to be right lay. When the strands rotate in a counterclockwise direction (as the threads do in a left hand bolt), the rope is left

lay. Right regular lay is furnished for all rope applications unless otherwise specified. When a lay-length is used as a unit of measure, it refers to the lengthwise distance of single strand extends in making one complete turn around the rope. Lay-length is measured in a straight line parallel to the center line of the rope, not by following the path of the strand. The appropriate time to replace a wire rope in service is frequently determined by counting the number of broken wires in the length of one rope lay.

Preformed Wire Rope – Preformed wire rope has definite characteristics which are advantageous on most wire rope applications. Preforming greatly reduces internal stresses, eases rope handling, and gives more equal distribution of load on the wires and strands. Preformed rope runs smoother and spools more uniformly on a drum than non-preformed, has greater flexibility and gives longer service life in bending.

Inspection of preformed rope: preformed wires tend to remain in position after breaking. This reduces the tendency for them to protrude and damage the wires next to them. However, because the wires do not protrude, we strongly suggest greater care and more thorough inspection to detect broken wires in a preformed wire rope.

How To Caliper Wire Rope – Rope diameter is specified by the user and is generally given in the equipment manufacturer's instruction manual accompanying the machine on which the rope is to be used. Rope diameters are determined by measuring the circle that just touches the extreme outer limits of the strands— that is, the greatest dimension that can be measured with a pair of parallel-jawed calipers or machinists's caliper square. A mistake could be made by measuring the smaller dimension. Three- and four-strand ropes are more difficult to measure for actual rope diameters.



RIGHT WAY
Always measure the *larger*
dimension, between the outer
limits of the strands



WRONG WAY
Do not measure the *smaller*
dimension across the "flats" of
the strands.

COMMON WIRE ROPE ABUSES

Neglect and abuse are the two chief enemies of wire rope life. One costly form of neglect is lack of proper field lubrication. Abuse takes many forms; improper reeling or unreeling, wrong size or worn sheaves, improper storage, and bad splicing are a few.

Condition of machinery – Wire rope performance depends upon the condition of the equipment on which it operates; poorly maintained equipment will usually result in reduced rope life.

Effects of shock-loading and vibration – The destructive effects of jerking or shock-loading are visually noticeable. Vibration has somewhat the same effect, and is equally destructive. An individual shock may be slight, but many rapidly repeated slight shocks can have the effect of several large shocks. Vibration which occurs directly above a load is often unavoidable. “Whipping” of the section of rope immediately above the load is also common. In these cases, rapid wire fatigue is possible. For reasons of safety, this section should be examined regularly.

Wire rope failure is usually cumulative. Each repeated overstress brings the rope nearer to failure. Thus, a wire rope may become fatigued to a point close to failure under a heavy load, and actually fall under a much lighter load.

Overstressing – In any hoisting operation, there should be no slack in the wire rope when the load is applied. Otherwise, the resulting stress will be excessive.

Overstressing can also be the result of too-rapid acceleration or deceleration. Wire rope will withstand considerable stress if the load is applied slowly. As with ordinary twine, a quick snap will cause overstressing and breakage. This applies both when starting to lift a load, and when bringing it to a stop.

Corrosion – Corrosion can seriously shorten wire rope life, both by metal loss and by formation of corrosion pits in the wires. These pits act as stress-concentration points in the wires in much the same manner as do nicks.

Wire rope left on machines shut down for long periods of time deteriorates rapidly. To preserve the rope for future use, it should be removed, cleaned, and thoroughly lubricated.

Causes of corrosion damage – Pitting, erosion, and surface effects of many different types can all result in corrosion damage. Because they tend to increase corrosion, the following conditions should be considered and noted when applicable, during the ordering of wire rope – acid and alkaline solutions, gases, fumes, brine and salt air, sulphurous compounds, and high humidity and temperature. Lubricants are readily available to reduce the severity of attack of most of these conditions.

Effects of severe heat – Where wire rope is subjected to severe heat (e.g., foundry cranes) it will not give the service expected because it will deteriorate more quickly.

Wire ropes exposed to hot-metal handling or other extreme heat sometimes require independent wire rope cores.

Shifting ropes from one job to another – Sometimes an idle wire rope from one operation is installed on another to keep the rope in continuous service. This extremely poor practice is an expensive “economy.”

Because wire rope tends to “set” to the conditions of its particular operating job, the differing bends, abrasions, and stresses of a new operation can produce premature failure. Therefore, for maximum life and efficiency, a rope should be used only on the job for which it has been specified.

Machinery operation – Some operators are harder on their machinery than others and as a result they get shorter rope life. In certain instances, enough extra work is done to more than offset the additional wear-and-tear on equipment and wire rope. The operation may be more efficient from the production standpoint as a result, but those in charge of rope purchases should be made aware of the probable reduction in rope life and increased rope costs.



Crushing. Because of loose winding on drum, rope was pulled in between underlying wraps and crushed out of shape.



Reverse bending. Running this rope over one sheave and under another caused fatigue breaks in wires.

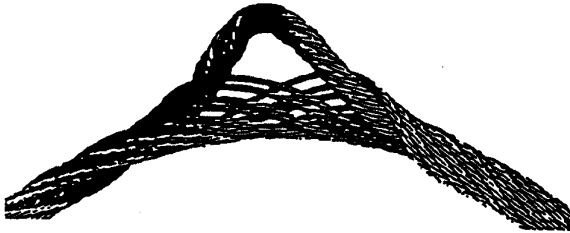

Too sudden load release. The sudden release of a load caused birdcaging. Here individual strands open away from each other, displacing the core.



Excessive exposure to elements. Too much exposure combined with surface wear and loss of lubrication caused corrosion and pitting.



Lack of lubrication. Premature breakage of wires resulted from "locking" of strands, which was caused by insufficient lubrication.

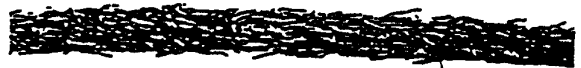

Too long in service. Repeated winding and overwinding of this rope on a drum while it was under heavy stress caused the unusually severe wear shown.



Infrequent inspection. Neglect of periodical inspection left this rope in service too long, resulting in considerable abrasion.



Undersize sheave grooves. Sheaves were too small, causing strands to pinch. Wires then fall in the valley between the strands.



Improper handling. Kink or "dog leg" was caused by improper handling and/or installation. A kink causes excessive localized or spot abrasion.



Poor work procedures. Damage to strands and wires resulted from electric arcing.



Lack of knowledge. Here's what occurs when a loop which has been "pulled through" and tightened remains in service.



Michigan Occupational Safety and Health Administration
 PO Box 30643
 Lansing, Michigan 48909-8143
 Ph: 517.322.1814
 Fx: 517.322.1775

The Department of Labor & Economic Growth will not discriminate against any individual or group because of race, sex, religion, age, national origin, color, marital status, disability, or political beliefs. If you need assistance with reading, writing, hearing, etc., under the Americans with Disabilities Act, you may make your needs known to this agency.