



DEPARTMENT OF LABOR & ECONOMIC GROWTH
DIRECTOR'S OFFICE
CONSTRUCTION SAFETY STANDARDS

Filed with the Secretary of State on June 23, 1992 (as amended September 3, 1996), (as amended April 11, 2000),
(as amended March 5, 2008)

These rules take effect 14 days after filing with the Secretary of State

(By authority conferred on the director of the department of labor and economic growth by sections 19 and 21 of 1974 PA 154, and Executive Reorganization Order Nos. 1996-2 and 2003-18, MCL 408.1019, 408.1021, 445.2001, and 445.2011)

R 408.43201, R 408.43202, R 408.43203, R 408.43204, R 408.43205, R 408.43206, R 408.43208, and R 408.43209 of the Michigan Administrative Code are amended, and R 408.43204a, R 408.43212, R 408.43214, R 408.43216, and R 408.43220 are added; and R 408.43210 is rescinded as follows:

PART 32. AERIAL WORK PLATFORMS

TABLE OF CONTENTS

R 408.43201. Scope	1	R 408.43207. Permits; training	3
R 408.43202. Equipment covered	1	R 408.43208. Preoperational procedures.....	4
R 408.43203. Employer and employee responsibility..	2	R 408.43209. Electrical hazards.....	4
R 408.43204. Definitions.....	2	R 408.43212. Vehicles; traffic control.....	6
R 408.43204a. Adoption of standards by reference; Access to other MIOSHA rules.....	2	R 408.43214. Fall protection.....	6
R 408.43205. Construction.....	3	R 408.43216. Operating procedures.....	6
R 408.43206. Inspection; maintenance; testing.....	3	R 408.43220. Figures.....	7

GENERAL PROVISIONS

R 408.43201. Scope.

Rule 3201. These rules apply to the construction, operation, maintenance, and inspection of aerial work platforms with either manual or powered mobility as used in construction operations as defined by 1974 PA 154, MCL 408.1001 to MCL 408.1094.

R 408.43202. Equipment covered.

Rule 3202. (1) These rules apply to equipment that has a primary function of elevating personnel, together with their tools and necessary materials, on a platform, which is mechanically positioned. The units covered are described by the following American national standards institute standards:

- (a) ANSI standard A92.2, 2002 edition, "Vehicle-Mounted Elevating and Rotating Aerial Devices," which is adopted by reference in R 408.43204a. This standard applies to vehicle-mounted devices installed on commercial chassis and covers the following type of units (See figure 1):
 - (i) Extensible boom aerial devices.
 - (ii) Aerial ladders.
 - (iii) Articulating boom aerial devices.
 - (iv) Vertical towers.
 - (v) A combination of any of the equipment specified in paragraphs (i) to (iv) of this subdivision.
- (b) ANSI standard A92.3, 2006 edition, "Manually Propelled Elevating Aerial Platforms," which is adopted by reference in R 408.43204a. This

standard applies to work platforms which are manually propelled, which are vertically adjustable by manual or powered means, and which may be towed or manually moved horizontally on wheels or casters that are an integral part of the work platform base. (See figure 2).

- (c) ANSI standard A92.5, 2006 edition, "Boom-Supported Elevating Work Platforms," which is adopted by reference in R 408.43204a. This standard applies to all integral frame, boom-supported elevating work platforms which telescope, articulate, rotate, or extend beyond the base dimensions. (See figure 3).
- (d) ANSI standard A92.6, 1999 edition, "Self-Propelled Elevating Work Platforms," which is adopted by reference in R 408.43204a. This standard applies to self-propelled vertically adjustable integral chassis work platforms. Such work platforms are power-operated with primary controls for all movement operated from the platform. (See figure 4).

(2) Equipment adapted to elevating personnel with a primary function other than elevating personnel, such as fork trucks or cranes, are not covered by these rules. Those types of equipment are provided for in construction safety standards Part 10. "Lifting and Digging Equipment," R 408.41001a to R 408.41099a and Part 13. "Mobile Equipment," R 408.101301.

Exception: If the above-adapted equipment is equipped with controls that can be operated from the platform, then the requirements of R 408.43205 to R 408.43216 shall apply.

R 408.43203. Employer and employee responsibility.

Rule 3203. (1) An employer shall do all of the following:

- (a) Provide training to employees in the operations, hazards, safeguards and safe practices described in these rules by a qualified person.
- (b) Ensure that employees do not engage in the activities to which these rules apply until such employees have received training.
- (c) Maintain an aerial device in a condition free of known defects and hazards which could cause an injury.

(2) An employee shall do both of the following:

- (a) Operate an aerial device only after being trained in the operations, hazards, safeguards and safe practices required by these rules by a qualified person and authorized by the employer.
- (b) Report known defects and hazards concerning an aerial device to the supervisor.

R 408.43204. Definitions.

Rule 3204. (1) "Aerial device" or "aerial work platform" means an entire device that is designed and manufactured to raise personnel to an elevated work position on a platform supported by scissors, masts, or booms.

(2) "Aerial ladder" means an aerial device that consists of a single- or multiple-section rung ladder.

(3) "Articulating boom" means an aerial device that has 2 or more hinged boom sections.

(4) "Authorized person" means a person who is approved and assigned to perform specific types of duties by the employer and who is qualified to perform those duties because of his or her training or experience.

(5) "Commercial chassis" means a vehicle that is built for over-the-road (roadway) travel.

(6) "Exposed power line" means a power line that is not isolated or guarded.

(7) "Extensible boom" means an aerial device, except for the aerial ladder-type, that has a telescopic boom.

(8) "Insulated aerial device" means an aerial work platform that is designed with dielectric components to meet specific electrical insulating ratings.

(9) "Mechanically positioned" means that the elevating assembly, whether a mechanical (cable or chain), hydraulic, pneumatic, electric or other powered mechanism, is used to raise or lower the platform.

(10) "Platform" means the portion of an aerial work platform, such as a bucket, basket, stand, cage, or the equivalent, that is designed to be occupied by personnel.

(11) "Power Line" means a distribution or transmission electrical line.

(12) "Qualified person" means a person who possesses a recognized degree, certificate, professional standing, or skill and who, by knowledge, training, and experience, has demonstrated the ability to deal with problems relating to the subject matter, the work, or the project.

(13) "Qualified telecommunications employee" means an employee trained to work on communication lines in the proximity of energized power transmission and distribution lines.

(14) "Vehicle" means any carrier that is not manually propelled.

(15) "Vehicle-mounted elevating and rotating work platform" means an aerial device or aerial work platform.

(16) "Vertical tower" means an aerial device that is designed to operate vertically on a level surface.

R 408.43204a. Adoption of standards by reference; access to other MIOSHA rules.

Rule 3204a. (1) The standards specified in this rule, except for the standards specified in subrule (2) of this rule, are adopted by reference.

- (a) The following ANSI standards are available from Global Engineering Documents, 15 Inverness Way East, Englewood, Colorado, 80112, USA, telephone number: 1-800-854-7179 or via the internet at web-site: <http://global.ihns.com>; at a cost, as of the time of adoption of these rules, as stated in this subrule:
 - (i) American National Standard Institute Standard ANSI A92.2, "Vehicle-Mounted Elevating and Rotating Aerial Devices," 2002 edition. Cost: \$68.00.
 - (ii) American National Standard Institute Standard ANSI A92.3, "Manually Propelled Elevating Aerial Platforms," 2006 edition. Cost: \$68.00.
 - (iii) American National Standard Institute Standard ANSI A92.5, "Boom-Supported Elevating Work Platforms," 2006 edition. Cost: \$68.00.
 - (iv) American National Standard Institute Standard ANSI A92.6, "Self-Propelled Elevating Work Platforms," 1999 edition. Cost \$68.00.

- (b) The "Manual on Uniform Traffic Control Devices for Streets and Highways, Part 6: Temporary Traffic Control," 2005 Michigan/2003 Federal Edition is available at no cost from the Michigan Department of Transportation via the Internet at website: www.michigan.gov/mdot. The entire 2005 MMUTCD may be purchased from Michigan Technological University, Local Technical Assistance Program, Room 309 Dillman Building, 1400 Townsend Drive, Houghton, Michigan, 49931; (906) 487-2102; at a cost of \$135.00 as of the time of publication of these rules.

- (c) The standards adopted in subrule 1(a) and (b) of this rule are also available for inspection at the Department of Labor and Economic Growth, MIOSHA Standards Section, 7150 Harris Drive, P.O. Box 30643, Lansing, Michigan, 48909-8143.
- (d) Copies of the standards adopted in subrule 1(a) and (b) of this rule may be obtained quickest from the publisher or may also be obtained from the Department of Labor and Economic Growth, MIOSHA Standards Section, 7150 Harris Drive, P.O. Box 30643, Lansing, Michigan, 48909-8143, at the cost charged in subrule 1(a) and (b), of this rule, plus \$20 for shipping and handling.

(2) The following Michigan Occupational Safety and Health Standards are referenced in these rules. Up to 5 copies of these standards may be obtained at no charge from the Michigan Department of Labor and Economic Growth, MIOSHA Standards Section, 7150 Harris Drive, P.O. Box 30643, Lansing, Michigan, 48909-8143 or via the internet at web-site: www.michigan.gov/mioshastandards. For quantities greater than 5, the cost, as of the time of adoption of these rules, is 4 cents per page.

- (a) Construction Safety Standard Part 6. Personal Protective Equipment, R 408.40601 to R 408.40641.
- (b) Construction Safety Standard Part 10. Lifting and Digging Equipment, R 408.41001a to R 408.41099a.
- (c) Construction Safety Standard Part 13. Mobile Equipment, R 408.101301.

- (d) Construction Safety Standard Part 22. Signals, Signs, Tags, and Barricades, R 408.42201 to R 408.42243.
- (e) Construction Safety Standard Part 45. Fall Protection, R 408.44501 to R 408.44502.
- (f) General Industry Safety Standard Part 7. Guards for Power Transmission, R 408.10701 to R 408.10765.

R 408.43205. Construction.

Rule 3205. (1) Aerial work platforms shall be designed, constructed, and tested so as to be in compliance with the requirements of the following applicable American national standards institute standards:

- (a) ANSI standard A92.2, 2002 edition, "Vehicle-Mounted Elevating and Rotating Aerial Devices."
- (b) ANSI standard A92.3, 2006 edition, "Manually Propelled Elevating Aerial Platforms."
- (c) ANSI standard A92.5, 2006 edition, "Boom-Supported Elevating Work Platforms."
- (d) ANSI standard A92.6, 1999 edition, "Self-Propelled Elevating Work Platforms."

These standards are adopted by reference in R 408.43204a.

(2) Aerial work platforms shall not be field-modified for uses other than those intended by the manufacturer, unless the modification has been certified in writing by the manufacturer or by any other equivalent entity, such as a nationally recognized testing laboratory, to be in compliance with the applicable ANSI standard and this rule, and to be at least as safe as the equipment was before modification.

(3) Directional controls shall be in compliance with all of the following provisions:

- (a) Be of the type that will automatically return to the off or neutral position when released.
- (b) Be protected against inadvertent operation.
- (c) Be clearly marked as to their intended function.
- (d) An overriding control shall be provided in the platform which must be continuously activated for platform directional controls to be operational and which automatically returns to the off position when released.

(4) Aerial work platforms shall be equipped with emergency controls at ground level.

(5) Emergency ground level controls shall be clearly marked as to their intended function and be capable of overriding the platform controls.

(6) All of the following information shall be clearly marked in a permanent manner on each aerial work platform:

- (a) Special workings, cautions, or restrictions necessary for operation.
- (b) Rated work load.
- (c) A clear statement of whether or not the aerial work platform is electrically insulated.

(7) Rotating shafts, gears, and other moving parts that are exposed to contact shall be guarded, as prescribed in general industry safety standard Part 7. "Guards for Power Transmission," R 408.10701 to R 408.10765.

(8) Attachment points shall be provided for fall protection devices for personnel who occupy the platform on aerial work platforms described in R 408.43202 (a) and (c). (See figures 1 and 3).

R 408.43206. Inspection; maintenance; testing.

Rule 3206. An employer shall comply with all of the following requirements:

- (a) Each aerial work platform shall be inspected, maintained, repaired, and kept in proper working condition in accordance with the manufacturer's or owner's operating or maintenance and repair manual or manuals.
- (b) Any aerial work platform found not to be in a safe operating condition shall be removed from service until repaired. All repairs shall be made by an authorized person in accordance with the manufacturer's or owner's operating or maintenance and repair manual or manuals.
- (c) If the aerial work platform is rated and used as an insulated aerial device, the electrical insulating components shall be tested for compliance with the rating of the aerial work platform in accordance with ANSI standard A92.2, 2002 edition, which was adopted in R 408.43204a. Such testing shall comply with all of the following provisions:
 - (i) The test shall be performed not less than annually.
 - (ii) Written, dated, and signed test reports shall be made available by the employer for examination by a department representative.
 - (iii) The insulated portion of an aerial device shall not be altered in any manner that might reduce its insulating value.
- (d) All danger, caution, and control markings and operational plates shall be legible and not obscured.

R 408.43207. Permits; training

Rule 3207. (1) An employer shall provide the operator of an aerial work platform with an aerial work platform permit.

- (2)** The requirements of subrule (8)(a), (b), (c), and (d) of this rule shall be met before an employee is issued a permit.
- (3)** A permit shall be carried by the operator or be available at the job site and shall be displayed upon request by a department of consumer and industry services representative.
- (4)** A permit shall indicate the type of aerial work platforms an operator has been trained on and is qualified to operate.
- (5)** A permit to operate an aerial work platform is valid only when performing work for the employer who issued the permit. A permit shall be issued for a period of not more than 3 years.
- (6)** A permit shall contain all of the following information (see sample permit):
 - (a) Firm name.
 - (b) Operator's name.
 - (c) Name of issuing authority. (Authorized by)
 - (d) The following types of aerial work platform the operator is authorized to operate:
 - (i) Vehicle-mounted elevating work platform such as:
 - (1) Extensible boom aerial devices.
 - (2) Aerial ladders.
 - (3) Actuating boom aerial devices.
 - (4) Vertical towers.
 - (ii) Manually propelled elevating work platforms.
 - (iii) Boom-supported elevating work platforms.
 - (iv) Self-propelled elevating work platforms.

- (e) Date issued.
- (f) Expiration date.
- (7)** A sample permit is set forth as follows:

SAMPLE PERMIT			
AERIAL WORK PLATFORM PERMIT			
<i>(Firm Name)</i>			

(Name)			
Type of aerial work platform authorized to operate:			
Date Issued	Type	Authorized by	Expiration Date
_____	_____	_____	_____
_____	_____	_____	_____
_____	_____	_____	_____

- (8)** An employer shall provide each employee who will operate the aerial work platform with instruction and training regarding the equipment before a permit is issued or reissued. Such instruction and training shall ensure that each operator is in compliance with the minimum following provisions:
 - (a) Is instructed by a qualified person in the intended purpose and function of each of the controls.
 - (b) Is trained by a qualified person or reads and understands the manufacturer's or owner's operating instructions and safety rules.
 - (c) Understands by reading or by having a qualified person explain, all decals, warnings, and instructions displayed on the aerial work platform.
 - (d) Reads and understands the provisions of this subrule and subrules (1) to (7) and (9) of this rule or be trained by a qualified person on their content.
- (9)** The manufacturer's operating instructions and safety rules shall be provided and maintained in a legible manner on each unit by the employer.

R 408.43208. Preoperational procedures.

Rule 3208. (1) An operator shall inspect an aerial work platform for defects that would affect its safe operation and use before it is used on each work shift. The visual inspection shall consist of all of the following procedures:

- (a) Visual inspection for all of the following:
 - (i) Cracked welds.
 - (ii) Bent or broken structural members.
 - (iii) Hydraulic or fuel leaks.
 - (iv) Damaged controls and cables.
 - (v) Loose wires.
 - (vi) Tire condition.
 - (vii) Fuel and hydraulic fluid levels.
 - (viii) Slippery conditions on the platform.
- (b) Operate all platform and ground controls to ensure that they perform their intended function.
- (2)** Before the aerial work platform is used, and during use on the job site, the operator shall inspect for all of the following:
 - (a) Ditches.
 - (b) Drop-offs.
 - (c) Holes.

- (d) Bumps and floor obstructions.
- (e) Debris.
- (f) Overhead obstructions.
- (g) Power lines.
- (h) Similar conditions to those specified in subdivisions (a) to (g) of this subrule. The area around the aerial work platform shall also be inspected to assure clearance for the platform and other parts of the unit.

(3) All unsafe items found as a result of the inspection of the aerial work platform or work area shall be corrected before further use of the aerial work platform.

(4) The employer shall ensure before the commencement of operations near power lines and when the clearances cannot be maintained as specified in Tables 1-3, that the owner, owner representative, or utility are notified with all pertinent information about the job.

(5) Any overhead wire shall be considered to be an energized line until the owner of the line, his or her authorized representative, or a utility representative assures one of the following:

- (a) The line is de-energized and has been visibly grounded.
- (b) The line is insulated for the system voltages and the task will not compromise the insulation of the conductor and/or cause an electrical hazard.

R 408.43209. Electrical hazards.

Rule 3209. (1) The employer shall ensure that an aerial work platform shall be operated so that the distances from energized power lines and equipment prescribed in Table 1 are maintained, except for the following:

- (a) As prescribed in subrule (2) of this rule addressing tree trimming.
- (b) As prescribed in subrule (3) of this rule addressing telecommunications.
- (c) Where insulating barriers are not a part of or an attachment to the aerial device that has been erected to prevent physical contact with the lines.

(2) A qualified lineman or a qualified line clearance tree trimmer shall maintain distances as prescribed in Table 2 when performing work from an aerial work platform on or near an exposed power line unless any of the following conditions exist:

- (a) The employee is insulated or guarded from the energized part by gloves or gloves and sleeves, as provided for and prescribed in Construction Safety Standard Part 6. "Personal Protective Equipment" and Construction Safety Standard Part 30. "Telecommunications."
- (b) The employee is insulated, isolated, or guarded from any other conductive part.
- (c) The energized part is insulated from the employee.

(3) A qualified telecommunications employee shall maintain the distances prescribed in Table 3 when working from an aerial lift, unless the employee is insulated, isolated, or guarded from any other conductive part or the energized part is insulated from the employee.

(4) Employees shall use insulated bucket, gloves and sleeves that are rated at more than the voltage to be worked on or that with which they might come into contact, to comply with subrules (2) and (3) of this rule.

(5) The clearances, as prescribed in Tables 1-3, do not apply when the owner of the line or his or her authorized representative, or utility assures that the conductor is insulated for the system voltages and the task will not compromise the insulation of the conductor and/or cause an electrical hazard.

(6) Tables 1, 2, and 3 read as follows:

Table 1
Minimum Clearance Distances for Equipment

Voltage	Clearance With Boom Raised	Clearance Boom Lowered and No Load in Transit
To 50 kV	10 feet	4 feet
Over 50 kV	10 feet + .4 inch per each 1 kV over 50 kV	10 feet
50 to 345 kV	--	10 feet
346 to 750 kV	--	15 feet

Table 2
**Minimum Working Distances for
Qualified Line-Clearance Tree Trimmers and Qualified Linemen**

Voltage Range Phase to Phase (kilovolts)	Minimum Working Distance
2.1 to 15.0	2 feet 0 inches (61 cm)
15.1 to 35.0	2 feet 4 inches (71 cm)
35.1 to 46.0	2 feet 6 inches (76 cm)
46.1 to 72.5	3 feet 0 inches (91 cm)
72.6 to 121.0	3 feet 4 inches (102 cm)
138.0 to 145.0	3 feet 6 inches (107 cm)
161.0 to 169.0	3 feet 8 inches (112 cm)
230.0 to 242.0	5 feet 0 inches (152 cm)
345.0 to 362.0	*7 feet 0 inches (213 cm)
550.0 to 552.0	*11 feet 0 inches (335 cm)
700.0 to 765.0	*15 feet 0 inches (457 cm)

*Note: For 345-362 kV., 500-552 kV., and 700-765 kV., the minimum working distance and the minimum clear hot stick distance may be reduced that such distances are not less than the shortest distance between the energized part and a grounded surface.

Table 3
**Minimum Approach Distances for
Qualified Telecommunications Employees**

Voltage Range (Nominal Phase to Phase)	Minimum Approach Distances
300 V and less	1 foot - 0 inches (30.5 cm)
Over 300 V, not over 750 V	1 foot - 6 inches (46 cm)
Over 750 V, not over 2 kV	2 feet - 0 inches (61 cm)
Over 2 kV, not over 15 kV	3 feet - 0 inches (91 cm)
Over 15 kV, not over 37 kV	3 feet - 6 inches (107 cm)
Over 37 kV, not over 87.5 kV	4 feet - 0 inches (122 cm)
Over 87.5 kV, not over 121 kV	4 feet - 6 inches (137 cm)
Over 121 kV, not over 140 kV	--

R 408.43210. Rescinded.**R 408.43212. Vehicles; traffic control.**

Rule 3212. (1) Before moving a vehicle supporting an aerial ladder for highway travel, employees shall secure ladders in the lower position and shall use the manually operated device at the base of the ladder, or other effective means to prevent elevation or rotation of the ladder.

(2) Before moving a vehicle supporting an aerial lift for travel, employees shall inspect the boom to ensure that it is properly cradled and the outriggers are in the stowed position, except as provided in subrule (3) of this rule.

(3) When a boom is elevated with employees in working position, the vehicle supporting an aerial device shall not be moved unless the equipment is specifically designed for this type of operation and meets the requirements of R 408.43205.

(4) Before and during travel, except as provided for horizontal movement in R 408.43216(9), an operator shall do all of the following:

- (a) Inspect to see that booms, platforms, aerial ladders, or towers are properly cradled or secured.
- (b) Ensure that outriggers are in a stored position.
- (c) Limit travel speed according to the following factors:
 - (i) Condition of the surface.
 - (ii) Congestion.
 - (iii) Slope.
 - (iv) Location of personnel.
 - (v) Other hazards.

(5) An employer shall ensure that operators of an aerial work platform over or adjacent to any public or private roadway maintain adequate clearances of all portions of the aerial work platform to prevent being struck by vehicular traffic.

(6) When aerial work platforms are in use, all traffic control requirements shall be in compliance with Part 6 of the 2005 Michigan Manual on Uniform Traffic Control Devices (MMUTCD), which is adopted in R 408.43204a, and Construction Safety Part 22. Signals, Signs, Tags, and Barricades, R 408.42201 to R 408.42243.

R 408.43214. Fall protection.

Rule 3214. (1) The employer shall provide a safety harness that has a lanyard which is in compliance with construction safety standard Part 45. "Fall Protection," R 408.44501 to R 408.44502 and which is affixed to attachment points provided and approved by the manufacturer. Any occupant of an aerial work platform described in the provisions of R 408.43202(a) and (c) and figures 1 and 3 shall use the harness. A fall arrest system shall only be used where the aerial lift is designed to withstand the vertical and lateral loads caused by an arrested fall.

(2) An employee may use a body belt with a restraint device with the lanyard and the anchor arranged so that the employee is not exposed to any fall distance. An employee shall use a restraint device where the aerial lift cannot withstand the vertical and lateral loads imposed by an arrested fall.

(3) An employee shall be prohibited from belting off to an adjacent pole, structure, or equipment while working from an aerial work platform.

(4) An employer shall not allow employees to exit an elevated aerial work platform, except where elevated work areas are inaccessible or hazardous to reach. Employees may exit the platform with the knowledge and consent of the employer. When employees exit to unguarded work areas, fall protection shall be provided and used as required in construction safety standard Part 45. "Fall Protection," R 408.44501 to R 408.44502.

(5) An employer shall provide for prompt rescue of employees in the event of a fall or shall ensure that employees are able to rescue themselves.

R 408.43216. Operating procedures.

Rule 3216 (1) The aerial work platform shall be used only in accordance with the manufacturers or owners operating instructions and safety rules.

(2) The designed rated capacity for a given angle of elevation shall not be exceeded.

(3) Proximity warning devices may be used, but shall not be used to avoid meeting the requirements of this rule.

(4) The manufacturer's rated load capacity shall not be exceeded. The employer shall ensure that the load and its distribution on the platform are in accordance with the manufacturer's specifications. The aerial work platform rated load capacity shall not be exceeded when loads are transferred to the platform at elevated heights.

(5) Only employees, their tools, and necessary materials shall be on or in the platform.

(6) The guardrail system of the platform shall not be used to support any of the following:

- (a) Materials.
- (b) Other work platforms.
- (c) Employees.

(7) Employees shall maintain firm footing on the platform while working on the platform. The use of railings, planks, ladders, or any other devices on the platform for achieving additional height is prohibited.

(8) Fuel gas cylinders shall not be carried on platforms that would allow the accumulation of gases.

(9) Only aerial work platforms that are equipped with a manufacturer's installed platform controls for horizontal movement shall be moved while in the elevated position.

(10) Before and during driving while elevated, an operator of a platform shall do both of the following:

- (a) Look in the direction of, and keep a clear view of, the path of travel and make sure that the path is firm and level.
- (b) Maintain a safe distance from all of the following:
 - (i) Obstacles.
 - (ii) Debris.
 - (iii) Drop-offs.
 - (iv) Holes.
 - (v) Depressions.
 - (vi) Ramps.
 - (vii) Overhead obstructions.
 - (viii) Overhead electrical lines.
 - (ix) Other hazards to safe elevated travel.

(11) Outriggers or stabilizers, when provided, and are to be used in accordance with the manufacturer's instruction. Brakes shall be set and outriggers and stabilizers shall be positioned on pads or a solid surface.

(12) Aerial work platforms shall be elevated only when on a firm and level surface or within the slope limits allowed by the manufacturer's instructions.

(13) A vehicle-mounted aerial work platform (figure 1) shall have its brakes set before elevating the platform.

(14) A vehicle-mounted aerial work platform (figure 1) shall have wheel chocks installed before using the unit on an incline.

(15) Climbers shall not be worn while performing work from an aerial work platform.

(16) Platform gates shall be closed while the platform is in an elevated position.

(17) Altering, modifying, or disabling safety devices or interlocks is prohibited.

(18) Care shall be taken by the employer to prevent ropes, cords, and hoses from becoming entangled in the aerial work platform.

(19) A platform operator shall ensure that the area surrounding the aerial work platform is clear of personnel and equipment before lowering the platform.

(20) The aerial work platform shall not be positioned against another object to steady the platform.

(21) The aerial work platform shall not be operated from a position on a truck, trailer, railway car, floating vessel, scaffold, or similar equipment.

(22) The boom and platform of the aerial work platform shall not be used to move or jack the wheels off the ground unless the machine is designed for that purpose by the manufacturer.

(23) If the platform or elevating assembly becomes caught, snagged, or otherwise prevented from normal motion by adjacent structures or other obstacles so that control reversal does not free the platform, all employees shall exit from the platform before attempts are made to free the platform.

(24) Stunt driving and horseplay are prohibited.

R 408.43220. Figures.

Rule 3220. Figures 1 to 4 are as follows:

**FIGURE 1
VEHICLE-MOUNTED ELEVATING WORK PLATFORM**

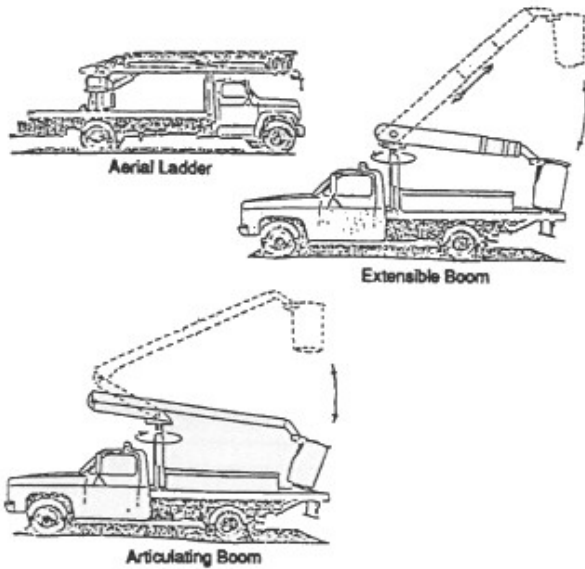

**FIGURE 3
BOOM-SUPPORTED ELEVATING WORK PLATFORMS**

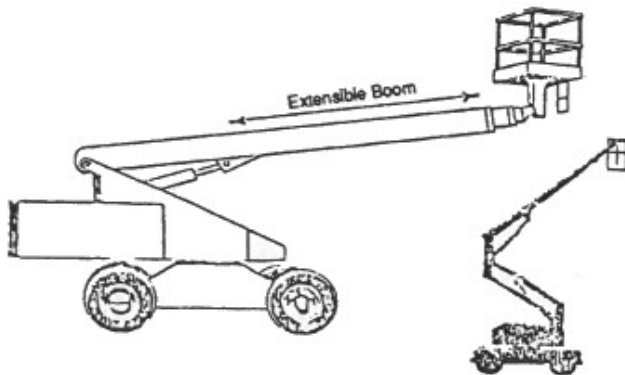

**FIGURE 2
MANUALLY PROPELLED ELEVATING WORK PLATFORMS**

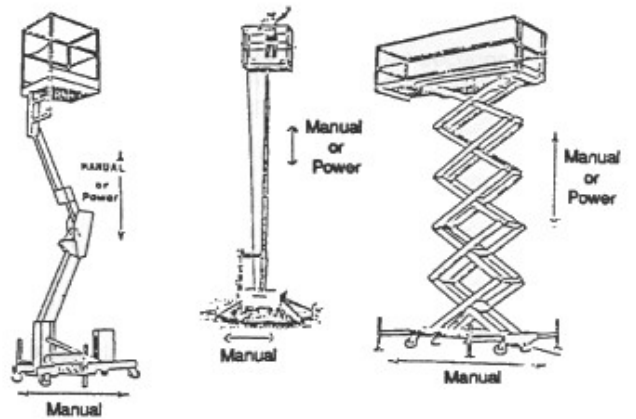

**FIGURE 4
SELF-PROPELLED ELEVATING WORK PLATFORMS**

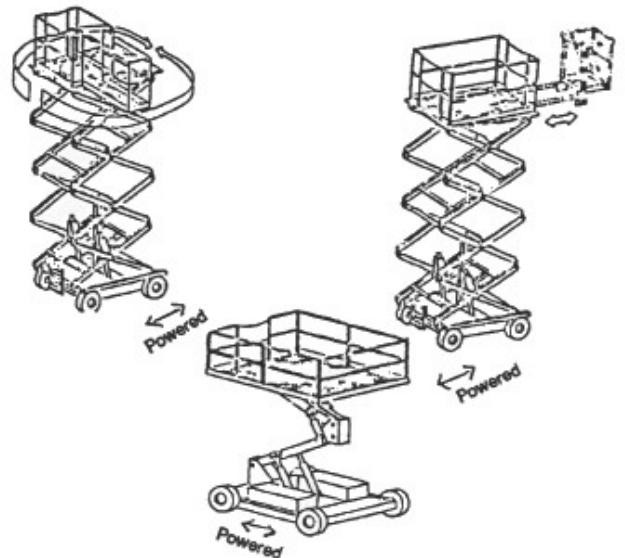



For further information contact
Michigan Occupational Safety and Health Administration
PO Box 30643
Lansing, Michigan 48909-8143
Ph: 517.322.1814
Fx: 517.322.1775

The Department of Labor & Economic Growth will not discriminate against any individual or group because of race, sex, religion, age, national origin, color, marital status, disability, or political beliefs. If you need assistance with reading, writing, hearing, etc., under the Americans with Disabilities Act, you may make your needs known to this agency.