



DEPARTMENT OF LICENSING AND REGULATORY AFFAIRS
DIRECTOR'S OFFICE
OCCUPATIONAL HEALTH STANDARDS

Filed with the Secretary of State on **August 17, 2009**

These rules become effective 7 days after filing with the Secretary of State

(By authority conferred on the director of the department of energy, labor, and economic growth by sections 14 and 24 of 1974 PA 154, and Executive Reorganization Order Nos. 1996-1, 1996-2, 2003-18, and 2008-4, MCL 408.1014, 408.1024, 330.3101, 445.2001, 445.2011, and 445.2025)

R 325.60601a, R 325.60601b, R 325.60602, R 325.60603, R 325.60604, R 325.60605, R 325.60606, R 325.60607, R 325.60608, R 325.60609, R 325.60610, R 325.60611, R 325.60612, R 325.60613, R 325.60614, R 325.60615, R 325.60616, R 325.60617, and R 325.60618 are added to the Michigan Administrative code and O.H. Rule 2410 is rescinded as follows:

PART 381. IONIZING RADIATION

TABLE OF CONTENTS

R 325.60601a Definitions.....	1	R 325.60611 Waste disposal.....	6
R 325.60601b Availability of referenced documents.....	2	R 325.60612 Notification of incidents.....	6
R 325.60602 Exposure of individuals to radiation in restricted areas.....	2	R 325.60613 Reports of overexposure and excessive levels and concentrations.....	6
R 325.60603 Exposure to airborne radioactive material.....	3	R 325.60614 Records.....	6
R 325.60604 Precautionary procedures and personal monitoring.....	3	R 325.60615 Disclosure to former employee of individual employee's records.....	7
R 325.60605 Caution signs, labels, and signals.....	3	R 325.60616 Nuclear Regulatory Commission licensees—NRC contractors operating NRC plants and facilities—NRC agreement state licensees or registrants.....	7
R 325.60606 Immediate evacuation warning signal.....	4	R 325.60617 Machine rooms in pulp, paper, and paperboard mills covered by Rule 5001 radiation.....	7
R 325.60607 Posting requirements; exemptions.....	5	R 325.60618 X-ray control in welding, cutting, and brazing covered by Rule 3240.....	7
R 325.60608 Radioactive materials packaged for shipment; exemptions.....	6		
R 325.60609 Instruction of personnel; posting.....	6		
R 325.60610 Storage of radioactive materials.....	6		

R 325.60601a Definitions

Rule 1a. Definitions applicable to these rules.

(1) "**Radiation**" includes alpha rays, beta rays, gamma rays, X-rays, neutrons, high-speed electrons, high-speed protons, and other atomic particles; but the term does not include sound or radio waves, visible light, or infrared or ultraviolet light.

(2) "**Radioactive material**" means any material which emits, by spontaneous nuclear disintegration, corpuscular or electromagnetic emanations.

(3) "**Restricted area**" means any area access to which is controlled by the employer for purposes of protection of individuals from exposure to radiation or radioactive materials.

(4) "**Unrestricted area**" means any area access to which is not controlled by the employer for purposes of protection of individuals from exposure to radiation or radioactive materials.

(5) "**Dose**" means the quantity of ionizing radiation absorbed, per unit of mass, by the body or by any portion of the body. When the provisions in these rules specify a dose during a period of time, the dose is the total quantity of radiation absorbed, per unit of mass, by the body or by any portion of the body during such period of time. Several different units of dose are in current use. Definitions of units

used in these rules are set forth in subrules (6) and (7) of this rule.

(6) "**Rad**" means a measure of the dose of any ionizing radiation to body tissues in terms of the energy absorbed per unit of mass of the tissue. One rad is the dose corresponding to the absorption of 100 ergs per gram of tissue (1 millirad (mrad) = 0.001 rad).

(7) "**Rem**" means a measure of the dose of any ionizing radiation to body tissue in terms of its estimated biological effect relative to a dose of 1 roentgen (r) of X-rays (1 millirem (mrem) = 0.001 rem). The relation of the rem to other dose units depends upon the biological effect under consideration and upon the conditions for irradiation. Each of the following is considered to be equivalent to a dose of 1 rem:

- (a) A dose of 1 roentgen due to X- or gamma radiation.
- (b) A dose of 1 rad due to X-, gamma, or beta radiation.
- (c) A dose of 0.1 rad due to neutrons or high-energy protons.
- (d) A dose of 0.05 rad due to particles heavier than protons and with sufficient energy to reach the lens of the eye.
- (e) If it is more convenient to measure the neutron flux, or equivalent, than to determine the neutron dose in rads, as provided in subrule (7)(c) of this rule, 1 rem

of neutron radiation may, for purposes of these rules, be assumed to be equivalent to 14 million neutrons per square centimeter incident upon the body; or, if there is sufficient information to estimate with reasonable accuracy the approximate distribution in energy of the neutrons, the incident number of neutrons per square centimeter equivalent to 1 rem may be estimated from table G-17:

TABLE G-17--NEUTRON FLUX DOSE EQUIVALENTS

Neutron energy (million electron volts (MeV))	Number of neutrons per square centimeter equivalent to a dose of 1 rem (neutrons/cm ²)	Average flux to deliver 100 millirem in 40 hours (neutrons/cm ² per sec.)
Thermal	970 x 10 ⁶	670
0.0001	720 x 10 ⁶	500
0.005	820 x 10 ⁶	570
0.02	400 x 10 ⁶	280
0.1	120 x 10 ⁶	80
0.5	43 x 10 ⁶	30
1.0	26 x 10 ⁶	18
2.5	29 x 10 ⁶	20
5.0	26 x 10 ⁶	18
7.5	24 x 10 ⁶	17
10	24 x 10 ⁶	17
10 to 30	14 x 10 ⁶	10

(8) For determining exposures to X- or gamma rays up to 3 Mev., the dose limits specified in these rules may be assumed to be equivalent to the "air dose." For the purpose of these rules "air dose" means that the dose is measured by a properly calibrated appropriate instrument in air at or near the body surface in the region of the highest dosage rate.

R 325.60601b Availability of referenced documents

Rule 1b. (1) The following Michigan Occupational Safety and Health standards are referenced in these rules. Up to 5 copies of these standards may be obtained at no charge from the Michigan Department of Energy, Labor, and Economic Growth, MIOSHA Standards Section, 7150 Harris Drive, P.O. Box 30643, Lansing, Michigan, 48909-8143 or via the internet at website:

<http://www.michigan.gov/mioshastandards>. For quantities greater than 5, the cost, as of the time of adoption of these rules, is 4 cents per page.

- (a) Occupational Health Standard Part 529 Welding, Cutting, & Brazing, Rule 3240.
- (b) Occupational Health Standard Part 476 Specifications for Accident Prevention Signs and Tags, Rule 4501.
- (c) Occupational Health Standard for Pulp, Paper, and Paperboard Mills, Rule 5001.

(2) The following United States government standards are referenced in these rules and are available without cost as of the time of adoption of these rules by accessing United States government websites:

- (a) The United States Department of Transportation, Title 49, Chapter I--Pipeline and Hazardous Materials Safety Administration is available for no cost at:

http://www.access.gpo.gov/nara/cfr/waisidx_07/49cfrv2_07.html.

- (b) The United States Department of Energy, Title 10, Chapter I--Nuclear Regulatory Commission, Part 20--Standards for Protection Against Radiation is available for no cost at:

http://www.access.gpo.gov/nara/cfr/waisidx_08/10cfr20_08.html.

- (c) The United States Atomic Energy Act of 1954, as amended (42 U.S.C. 2011 et seq.) is available for no cost at: <http://www.nrc.gov/reading-rm/doc-collections/nuregs/staff/sr0980/rev1/vol-1-sec-1.pdf>.

(3) The American National Standards Institute Z54.1, Nonmedical X-ray and Sealed Gamma-ray Sources, 1963 Edition is adopted by reference in these rules and is available from IHS Global, 15 Inverness Way East, Englewood, Colorado, 80112, USA, telephone number: 1-800-854-7179 or via the internet at website: <http://global.ihs.com>; at a cost of \$49.00 as of the time of adoption of these rules.

(4) The standards referenced in this rule are also available for inspection at the Department of Energy, Labor, and Economic Growth, MIOSHA Standards Section, 7150 Harris Drive, P.O. Box 30643, Lansing, Michigan, 48909-8143.

(5) Copies of the standards referenced in subrules (2) and (3) of this rule may also be obtained from the Department of Energy, Labor, and Economic Growth, MIOSHA Standards Section, 7150 Harris Drive, P.O. Box 30643, Lansing, Michigan, 48909-8143, at the respective cost charged in each subrule, plus \$20.00 for shipping and handling.

R 325.60602 Exposure of individuals to radiation in restricted areas

Rule 2. (1) Except as provided in subrule (2) of this rule, no employer shall possess, use, or transfer sources of ionizing radiation in such a manner as to cause any individual in a restricted area to receive in any period of 1 calendar quarter from sources in the employer's possession or control a dose in excess of the limits specified in table G-18.

TABLE G-18

	Rems per calendar quarter
Whole body: Head and trunk; active bloodforming organs; lens of eyes; or gonads	1¼
Hands and forearms; feet and ankles	18¾
Skin of whole body	7½

(2) An employer may permit an individual in a restricted area to receive doses to the whole body greater than those permitted under subrule (1) of this rule, if all of the following apply:

- (a) During any calendar quarter the dose to the whole body does not exceed 3 rem.
- (b) The dose to the whole body, when added to the accumulated occupational dose to the whole body, does not exceed 5 (N-18) rem, where "N" equals the individual's age in years at his or her last birthday.
- (c) The employer maintains adequate past and current exposure records which show that the addition of such a dose will not cause the individual to exceed the amount authorized in this rule. As used in this rule, "dose to the whole body" includes any dose to the whole body, gonad, active bloodforming organs, head and trunk, or lens of the eye.

(3) An employer shall not permit any employee who is under 18 years of age to receive in any period of 1 calendar quarter a dose in excess of 10 percent of the limits specified in table G-18.

(4) "Calendar quarter" means any 3-month period determined in 1 of the following ways:

- (a) The first period of any year may begin on any date in January if the second, third, and fourth periods accordingly begin on the same date in April, July, and October, respectively, and the fourth period extends into January of the succeeding year, if necessary to complete a 3-month quarter. During the first year of use of this method of determination, the first period for that year shall also include any additional days in January preceding the starting date of the first period.
- (b) The first period in a calendar year of 13 complete, consecutive calendar weeks; the second period in a calendar year of 13 complete, consecutive weeks; the third period in a calendar year of 13 complete, consecutive calendar weeks; the fourth period in a calendar year of 13 complete, consecutive calendar weeks. If at the end of a calendar year there are any days not falling within a complete calendar week of that year, such days shall be included within the last complete calendar week of that year. If at the beginning of any calendar year there are days not falling within a complete calendar week of that year, such days shall be included within the last complete calendar week of the previous year.
- (c) The 4 periods in a calendar year may consist of the first 14 complete, consecutive calendar weeks; the next 12 complete, consecutive calendar weeks, the next 14 complete, consecutive calendar weeks, and the last 12 complete, consecutive calendar weeks. If at the end of a calendar year there are any days not falling within a complete calendar week of that year, such days shall be included (for purposes of these rules) within the last complete calendar week of the year. If at the beginning of any calendar year there are days not falling within a complete calendar week of that year, such days shall be included (for purposes of these rules) within the last complete week of the previous year.

R 325.60603 Exposure to airborne radioactive material

Rule 3. (1) An employer shall not possess, use, or transport radioactive material in such a manner as to do the following:

- (a) Cause any employee, within a restricted area, to be exposed to airborne radioactive material in an average concentration in excess of the limits specified in table 1 of appendix B to 10 CFR Part 20. The limits given in table 1 are for exposure to the concentrations specified for 40 hours in any workweek of 7 consecutive days. In any such period where the number of hours of exposure is less than 40, the limits specified in the table may be increased proportionately. In any such period where the number of hours of exposure is greater than 40, the limits specified in the table shall be decreased proportionately.

(b) Cause any individual within a restricted area, who is under 18 years of age, to be exposed to airborne radioactive material in an average concentration in excess of the limits specified in table II of appendix B to 10 CFR Part 20. For purposes of this rule, concentrations may be averaged over periods not greater than 1 week.

(2) "Exposed" as used in this rule means that the individual is present in an airborne concentration.

(3) No allowance shall be made for the use of protective clothing, equipment, or particle size.

R 325.60604 Precautionary procedures and personal monitoring

Rule 4. (1) Every employer shall evaluate the radiation hazards incident to the production, use, release, disposal, or presence of radioactive materials or other sources of radiation under a specific set of conditions. When appropriate, such evaluation shall include a physical survey of the location of materials and equipment, and measurements of levels of radiation or concentrations of radioactive material present.

(2) Every employer shall supply appropriate personnel monitoring equipment, such as film badges, pocket chambers, pocket dosimeters, or film rings, and shall require the use of such equipment by employees as follows:

- (a) Each employee who enters a restricted area under such circumstances that he or she receives, or is likely to receive, a dose in any calendar quarter in excess of 25 percent of the applicable value specified in R 325.60602(1).
- (b) Each employee less than 18 years of age who enters a restricted area where he or she receives, or is likely to receive, a dose in any calendar quarter in excess of 5 percent of the applicable value specified in R 325.60602(1).
- (c) Each employee who enters a high radiation area.
- (3) As used in these rules:
 - (a) "Personnel monitoring equipment" means devices designed to be worn or carried by an individual for the purpose of measuring the dose received (for example, film badges, pocket chambers, pocket dosimeters, film rings).
 - (b) "Radiation area" means any area, accessible to personnel, in which there exists radiation at such levels that a major portion of the body could receive in any 1 hour a dose in excess of 5 millirem, or in any 5 consecutive days a dose in excess of 100 millirem.
 - (c) "High radiation area" means any area, accessible to personnel, in which there exists radiation at such levels that a major portion of the body could receive in any 1 hour a dose in excess of 100 millirem.

R 325.60605 Caution signs, labels, and signals

Rule 5. (1) Symbols prescribed by this rule shall use the conventional radiation caution colors (magenta or purple on yellow background). The symbol prescribed by this rule is the conventional 3-bladed design.

FIGURE G-10

RADIATION SYMBOL

1. Cross-hatched area is to be magenta or purple.
2. Background is to be yellow.

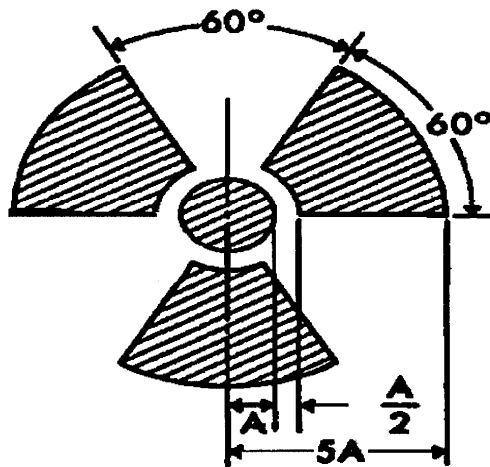

(2) Radiation area. Each radiation area shall be conspicuously posted with a sign or signs bearing the radiation caution symbol described in subrule (1) of this rule and the following words:

**CAUTION
RADIATION AREA**

- (3) The following apply to high radiation area:
- (a) Each high radiation area shall be conspicuously posted with a sign or signs bearing the radiation caution symbol and the following words:

**CAUTION
HIGH RADIATION AREA**

- (b) Each high radiation area shall be equipped with a control device which shall either cause the level of radiation to be reduced below that at which an individual might receive a dose of 100 millirems in 1 hour upon entry into the area or shall energize a conspicuous visible or audible alarm signal in a manner that the individual entering and the employer or a supervisor of the activity are made aware of the entry. In the case of a high radiation area established for a period of 30 days or less, such control device is not required.

(4) The following apply to airborne radioactivity area:

- (a) As used in these rules, "airborne radioactivity area" means either of the following:
- (i) Any room, enclosure, or operating area in which airborne radioactive materials, composed wholly or partly of radioactive material, exist in concentrations in excess of the amounts specified in column 1 of table 1 of appendix B to 10 CFR Part 20.
 - (ii) Any room, enclosure, or operating area in which airborne radioactive materials exist in concentrations which, averaged over the number of hours in any week during which individuals are in the area, exceed 25 percent of the amounts specified in column 1 of table 1 of appendix B to 10 CFR Part 20.

- (b) Each airborne radioactivity area shall be conspicuously posted with a sign or signs bearing the radiation caution symbol described in subrule (1) of this rule and the following words:

**CAUTION
AIRBORNE RADIOACTIVITY AREA**

- (5) The following apply to additional requirements:
- (a) Each area or room in which radioactive material is used or stored and which contains any radioactive material (other than natural uranium or thorium) in any amount exceeding 10 times the quantity of such material specified in appendix C to 10 CFR Part 20 shall be conspicuously posted with a sign or signs bearing the radiation caution symbol described in subrule (1) of this rule and the following words:

**CAUTION
RADIOACTIVE MATERIALS**

- (b) Each area or room in which natural uranium or thorium is used or stored in an amount exceeding 100 times the quantity of such material specified in appendix C to 10 CFR Part 20 shall be conspicuously posted with a sign or signs bearing the radiation caution symbol described in subrule (1) of this rule and the following words:

**CAUTION
RADIOACTIVE MATERIALS**

(6) The following apply to containers:

- (a) Each container in which is transported, stored, or used a quantity of any radioactive material (other than natural uranium or thorium) greater than the quantity of such material specified in appendix C to 10 CFR Part 20 shall bear a durable, clearly visible label bearing the radiation caution symbol described in subrule (1) of this rule and the following words:

**CAUTION
RADIOACTIVE MATERIALS**

- (b) Each container in which natural uranium or thorium is transported, stored, or used in a quantity greater than 10 times the quantity specified in appendix C to 10 CFR Part 20 shall bear a durable, clearly visible label bearing the radiation caution symbol described in subrule (1) of this rule and the following words:

**CAUTION
RADIOACTIVE MATERIALS**

- (c) Notwithstanding the provisions of subrule (6)(a) and (b) of this rule a label shall not be required under either of the following circumstances:

- (i) If the concentration of the material in the container does not exceed that specified in column 2 of table 1 of appendix B to 10 CFR Part 20.
- (ii) For laboratory containers, such as beakers, flasks, and test tubes, used transiently in laboratory procedures, when the user is present.

- (d) Where containers are used for storage, the labels required in this subrule shall state also the quantities and kinds of radioactive materials in the containers and the date of measurement of the quantities.

Also see Occupational Health Standard Part 476 Specifications for Accident Prevention Signs and Tags, Rule 4501.

R 325.60606 Immediate evacuation warning signal

Rule 6. (1) The following apply to signal characteristics:

- (a) The signal shall be a midfrequency complex sound wave amplitude modulated at a subsonic frequency. The complex sound wave in free space shall have a fundamental frequency (f_1) between 450 and 500 hertz (Hz) modulated at a subsonic rate between 4 and 5 hertz.
- (b) The signal generator shall not be less than 75 decibels at every location where an individual may

- be present whose immediate, rapid, and complete evacuation is essential.
- (c) A sufficient number of signal units shall be installed so the requirements of subrule (1)(b) of this rule are met at every location where an individual may be present whose immediate, rapid, and complete evacuation is essential.
 - (d) The signal shall be unique in the plant or facility in which it is installed.
 - (e) The minimum duration of the signal shall be sufficient to ensure that all affected persons hear the signal.
 - (f) The signal-generating system shall respond automatically to an initiating event without requiring any human action to sound the signal.
- (2) The following apply to design objectives:
- (a) The signal-generating system shall be designed to incorporate components which enable the system to produce the desired signal each time it is activated within one-half second of activation.
 - (b) The signal-generating system shall be provided with an automatically activated secondary power supply which is adequate to simultaneously power all emergency equipment to which it is connected, if operation during power failure is necessary, except in those systems using batteries as the primary source of power.
 - (c) All components of the signal-generating system shall be located to provide maximum practicable protection against damage in case of fire, explosion, corrosive atmosphere, or other environmental extremes consistent with adequate system performance.
 - (d) The signal-generating system shall be designed with the minimum number of components necessary to make it function as intended, and should utilize components which do not require frequent servicing such as lubrication or cleaning.
 - (e) Where several activating devices feed activating information to a central signal generator, failure of any activating device shall not render the signal-generator system inoperable to activating information from the remaining devices.
 - (f) The signal-generating system shall be designed to enhance the probability that alarm occurs only when immediate evacuation is warranted. The number of false alarms shall not be so great that the signal will come to be disregarded and shall be low enough to minimize personal injuries or excessive property damage that might result from such evacuation.
- (3) The following apply to testing:
- (a) Initial tests, inspections, and checks of the signal-generating system shall be made to verify that the fabrication and installation were made according to design plans and specifications and to develop a thorough knowledge of the performance of the system and all components under normal and hostile conditions.
 - (b) Once the system has been placed in service, periodic tests, inspections, and checks shall be made to minimize the possibility of malfunction.
 - (c) Following significant alterations or revisions to the system, tests and checks similar to the initial installation tests shall be made.
 - (d) Tests shall be designed to minimize hazards while conducting the tests.
 - (e) Before normal operation, the signal-generating system shall be checked physically and functionally to assure reliability and to demonstrate accuracy and performance. Specific tests shall include all of the following:
 - (i) All power sources.
 - (ii) Calibration and calibration stability.
 - (iii) Trip levels and stability.
 - (iv) Continuity of function with loss and return of required services such as AC or DC power and air pressure.
 - (v) All indicators.
 - (vi) Trouble indicator circuits and signals, where used.
 - (vii) Air pressure, if used.
 - (viii) Determine that sound level of the signal is within the limit of subrule (1)(b) of this rule at all points that require immediate evacuation.
 - (f) In addition to the initial startup and operating tests, periodic scheduled performance tests and status checks shall be made to ensure that the system is at all times operating within design limits and capable of the required response. Specific periodic tests or checks or both shall include all of the following:
 - (i) Adequacy of signal activation device.
 - (ii) All power sources.
 - (iii) Function of all alarm circuits and trouble indicator circuits including trip levels.
 - (iv) Air pressure (if used).
 - (v) Function of entire system including operation without power where required.
 - (vi) Complete operational tests including sounding of the signal and determination that sound levels are adequate.
 - (g) Periodic tests shall be scheduled on the basis of need, experience, difficulty, and disruption of operations. The entire system shall be operationally tested at least quarterly.
 - (h) All employees whose work may necessitate their presence in an area covered by the signal shall be made familiar with the actual sound of the signal--preferably as it sounds at their work location. Before placing the system into operation, all employees normally working in the area shall be made acquainted with the signal by actual demonstration at their work locations.
- R 325.60607 Posting requirements; exemptions**
- Rule 7.** Notwithstanding the provisions of R 325.60605 all of the following apply:
- (a) A room or area is not required to be posted with a caution sign because of the presence of a sealed source if the radiation level 12 inches from the surface of the source container or housing does not exceed 5 millirem per hour.
 - (b) Rooms or other areas in onsite medical facilities are not required to be posted with caution signs because of the presence of patients containing radioactive material if there are personnel in attendance who shall take the precautions necessary to prevent the exposure of any individual to radiation or radioactive material in excess of the limits established in these rules.
 - (c) Caution signs are not required to be posted at areas or rooms containing radioactive materials for periods of less than 8 hours if both of the following apply:

- (i) The materials are constantly attended during such periods by an individual who shall take the precautions necessary to prevent the exposure of any individual to radiation or radioactive materials in excess of the limits established in these rules.
- (ii) The area or room is subject to the employer's control.

R 325.60608 Radioactive materials packaged for shipment; exemptions

Rule 8. Radioactive materials packaged and labeled in accordance with regulations of the Department of Transportation published in 49 CFR Chapter I, are exempt from the labeling and posting requirements of this rule during shipment if the inside containers are labeled according to R 325.60605.

R 325.60609 Instruction of personnel; posting

Rule 9. (1) Employers regulated by the Nuclear Regulatory Commission shall be governed by 10 CFR Part 20 standards. Employers in a state named in R 325.60616(3) shall be governed by the requirements of the laws and regulations of that state. All other employers shall be subject to subrules (2) and (3) of this rule.

- (2) The employer shall do all of the following:
 - (a) Inform all individuals working in or frequenting any portion of a radiation area of the occurrence of radioactive materials or of radiation in such portions of the radiation area.
 - (b) Instruct all individuals in the safety problems associated with exposure to such materials or radiation and in precautions or devices to minimize exposure and the applicable provisions of these rules for the protection of employees from exposure to radiation or radioactive materials.
 - (c) Advise all individuals of reports of radiation exposure which employees may request under these rules.
- (3) Each employer to whom these rules apply shall do either of the following:
 - (a) Conspicuously post a current copy of its provisions and a copy of the operating procedures applicable to the work in locations where employees working in or frequenting radiation areas will observe these documents on the way to and from their place of employment.
 - (b) Keep documents available for examination of employees upon request.

R 325.60610 Storage of radioactive materials

Rule 10. Radioactive materials stored in a nonradiation area shall be secured against unauthorized removal from the place of storage.

R 325.60611 Waste disposal

Rule 11. An employer shall not dispose of radioactive material except by transfer to an authorized recipient, or in a manner approved by the Nuclear Regulatory Commission or a state named in R 325.60616(3).

R 325.60612 Notification of incidents

Rule 12. (1) Immediate notification. Each employer shall immediately notify the Department of Environmental Quality for employees not protected by the Nuclear Regulatory Commission by means of 10 CFR Part 20;

R 325.60616(2) or the requirements of the laws and regulations of states named in R 325.60616(3) by telephone or telegraph of any incident involving radiation which may have caused or threatens to cause either of the following:

- (a) Exposure of the whole body of any individual of 25 rems or more of radiation; exposure of the skin of the whole body of any individual to 150 rems or more of radiation; or exposure of the feet, ankles, hands, or forearms of any individual to 375 rems or more of radiation.
- (b) The release of radioactive material in concentrations which, if averaged over a period of 24 hours, would exceed 5,000 times the limit specified for such materials in table II of appendix B to 10 CFR Part 20.
 - (2) Twenty-four hour notification. Each employer shall within 24 hours following its occurrence notify the Department of Environmental Quality for employees not protected by the Nuclear Regulatory Commission by means of 10 CFR Part 20; R 325.60616(2) or the requirements of the laws and regulations of states named in R 325.60616(3) by telephone or telegraph of any incident involving radiation which may have caused or threatens to cause any of the following:
 - (a) Exposure of the whole body of any individual to 5 rems or more of radiation.
 - (b) Exposure of the skin of the whole body of any individual to 30 rems or more of radiation.
 - (c) Exposure of the feet, ankles, hands, or forearms to 75 rems or more of radiation.

R 325.60613 Reports of overexposure and excessive levels and concentrations

Rule 13. (1) In addition to any notification required by R 325.60612 each employer shall make a written report within 30 days to the Department of Environmental Quality for employees not protected by the Nuclear Regulatory Commission by means of 10 CFR Part 20; or under R 325.60616(2) or the requirements of the laws and regulations of states named in R 325.60616(3) of each exposure of an individual to radiation or concentrations of radioactive material in excess of any applicable limit in these rules. Each report required under this rule shall describe the extent of exposure of persons to radiation or to radioactive material; levels of radiation and concentration of radioactive material involved, the cause of the exposure, levels of concentrations; and corrective steps taken or planned to assure against a recurrence.

(2) If an employer is required under this rule to report to the Department of Environmental Quality any exposure of an individual to radiation or to concentrations of radioactive material, the employer shall also notify that individual of the nature and extent of exposure. The notice shall be in writing and shall contain the following statement: "You should preserve this report for future reference."

R 325.60614 Records

Rule 14. (1) Every employer shall maintain records of the radiation exposure of all employees for whom personnel monitoring is required under R 325.60604 and advise each employee of their individual exposure on at least an annual basis.

(2) Every employer shall maintain records in the same units used in tables in R 325.60602 and appendix B to 10 CFR Part 20.

R 325.60615 Disclosure to former employee of individual employee's records

Rule 15. At the request of a former employee, an employer shall furnish to the employee a report of the employee's exposure to radiation as shown in records maintained by the employer under R 325.60614(1). The report shall be furnished within 30 days from the time the request is made and shall cover each calendar quarter of the individual's employment involving exposure to radiation or for a lesser period if requested by the employee. The report shall also include the results of any calculations and analysis of radioactive material deposited in the body of the employee. The report shall be in writing and contain the following statement: "You should preserve this report for future reference."

R 325.60616 Nuclear Regulatory Commission licensees—NRC contractors operating NRC plants and facilities—NRC agreement state licensees or registrants

Rule 16. (1) Any employer who possesses or uses source material, byproduct material, or special nuclear material, as defined in the Atomic Energy Act of 1954, as amended, under a license issued by the Nuclear Regulatory Commission and in accordance with the requirements of 10 CFR Part 20 shall be deemed to be in compliance with these rules with respect to possession and use.

(2) NRC contractors operating NRC plants and facilities: Any employer who possesses or uses source material, byproduct material, special nuclear material, or other radiation sources under a contract with the Nuclear Regulatory Commission for the operation of NRC plants and facilities and in accordance with the standards, procedures, and other requirements for radiation protection established by the commission for such contract pursuant to the Atomic Energy Act of 1954, as amended (42 U.S.C. 2011 et seq.), shall be deemed to be in compliance with these rules with respect to possession and use.

(3) NRC—agreement state licensees or registrants the following apply:

- (a)** Atomic Energy Act sources. Any employer who possesses or uses source material, byproduct material, or special nuclear material, as defined in the Atomic Energy Act of 1954, as amended (42 U.S.C. 2011 et seq.), and has either registered such sources with, or is operating under a license issued by, a state which has an agreement in effect with the Nuclear Regulatory Commission under section 274(b) (42 U.S.C. 2021(b)) of the Atomic Energy Act of 1954, as amended, and according to the state's laws and regulations, shall be deemed to be in compliance with the radiation requirements of these rules, insofar as his or her possession and use of such material is concerned, unless the Secretary of Labor, after conference with the Nuclear Regulatory Commission, shall determine that the state's program for control of these radiation sources is incompatible with the requirements of these rules.

Such agreements currently are in effect only in the states of Alabama, Arkansas, California, Kansas, Kentucky, Florida, Mississippi, New Hampshire, New York, North Carolina, Texas, Tennessee, Oregon, Idaho, Arizona, Colorado, Louisiana, Nebraska, Washington, Maryland, North Dakota, South Carolina, and Georgia.

- (b)** Other sources. Any employer who possesses or uses radiation sources other than source material, byproduct material, or special nuclear material, as defined in the Atomic Energy Act of 1954, as amended (42 U.S.C. 2011 et seq.), and has either registered such sources with, or is operating under a license issued by a state which has an agreement in effect with the Nuclear Regulatory Commission pursuant to section 274(b) (42 U.S.C. 2021(b)) of the Atomic Energy Act of 1954, as amended, and in accordance with the requirements of that state's laws and regulations shall be deemed to be in compliance with the radiation requirements of these rules, as far as his or her possession and use of such material is concerned, if the state's program for control of these radiation sources is the subject of a currently effective determination by the Assistant Secretary of Labor that such program is compatible with these rules. Such determinations currently are in effect only in the states of Alabama, Arkansas, California, Kansas, Kentucky, Florida, Mississippi, New Hampshire, New York, North Carolina, Texas, Tennessee, Oregon, Idaho, Arizona, Colorado, Louisiana, Nebraska, Washington, Maryland, North Dakota, South Carolina, and Georgia.

R 325.60617 Machine rooms in pulp, paper, and paperboard mills covered by Rule 5001 radiation

Rule 17. Special standards regarding the use of radiation equipment shall be posted and followed as required by these rules.

R 325.60618 X-ray control in welding, cutting, and brazing covered by Rule 3240

Rule 18. (1) Transmission pipeline: X-ray inspection. The use of X-rays and radioactive isotopes for the inspection of welded pipeline joints shall be carried out in conformance with the American National Standards Institute Z54.1, Safety Standard for Nonmedical X-ray and Sealed Gamma-ray Sources, as adopted in R 325.60601b.

(2) Mechanical piping systems: X-ray inspection. The use of X-rays and radioactive isotopes for the inspection of welded piping joints shall be in conformance with the American National Standards Institute Z54.1, Safety Standard for Nonmedical X-ray and Sealed Gamma-ray Sources, as adopted in R 325.60601b.

Rule 2410 Rescinded



Michigan Occupational Safety and Health Administration
PO Box 30643
Lansing, Michigan 48909-8143
Ph: 517.322.1845

The Department of Licensing and Regulatory Affairs will not discriminate against any individual or group because of race, sex, religion, age, national origin, color, marital status, disability, or political beliefs. Auxiliary aids, services and other reasonable accommodations are available upon request to individuals with disabilities.