



DEPARTMENT OF LICENSING AND REGULATORY AFFAIRS
DIRECTOR'S OFFICE
GENERAL INDUSTRY SAFETY STANDARDS

Filed with the Secretary of State on April 30, 1974 (as amended August 2, 1976)
(as amended April 2, 1979) (as amended March 23, 1982) (as amended June 1, 1994) **(as amended January 14, 1998)**

These rules take effect 15 days after filing with the Secretary of State

(By authority conferred on the director of the department of consumer and industry services by sections 16 and 21 of Act No. 154 of the Public Acts of 1974, as amended, and Executive Reorganization Order No. 1996-2, being §§408.1016, 408.1021, and 445.2001 of the Michigan Compiled Laws)

R 408.10351 of the Michigan Administrative Code is amended to read as follows:

PART 3. FIXED LADDERS

TABLE OF CONTENTS

R 408.10301 Purpose and scope.	1	R 408.10331 Protection from deterioration.....	3
R 408.10305 Definitions; A to F.....	1	R 408.10333 Maintenance.	3
R 408.10306 Definitions; G to M.....	2	R 408.10335 Clearance.....	3
R 408.10307 Definitions; P to R.....	2	R 408.10341 Special rules for utility manhole fixed ladders.	4
R 408.10308 Definitions; S to W.....	2	R 408.10342 Step bolts and manhole steps; specifications.	5
R 408.10310 Surface conditions and clearances.....	2	R 408.10345 Design of manhole steps.	5
R 408.10311 Employee training; ladder use restrictions.....	2	R 408.10351 Safety devices.....	5
R 408.10321 Design.	2	R 408.10352 Cages.	5
R 408.10323 Rungs, cleats, and steps; spacing; maintenance; load requirements.	2	R 408.10353 Ladder wells.....	6
R 408.10324 Rungs and cleats; length; design; diameter of metal rungs; construction of metal cleats; adoption by reference of standards for wood cleats and other wood components.	2	R 408.10354 Personal fall protection systems.	6
R 408.10325 Side Rails.	3	R 408.10355 Landing platforms.	6
R 408.10326 Fastenings.....	3	R 408.10357 Ladder extensions.....	7
R 408.10328 Splices.....	3	R 408.10361 Grab bars.	7
		R 408.10365 Pitch.....	7
		R 408.10371 Test methods for personal fall arrest systems.....	8
		R 408.10372 Test methods for positioning device systems.....	9

GENERAL PROVISIONS

R 408.10301 Purpose and scope.

Rule 301. This part is intended to provide reasonable safety for life and limb by establishing minimum standards for the design and installation of fixed ladders and safe use by employees. A fixed ladder shall be designed to carry a designed minimum load under varying circumstances depending upon placement, length, method of fastening and other requirements of the installation. Therefore, all parts and appurtenances necessary for a safe and efficient ladder shall necessarily be integral parts of that design. Utility poles and radio, television and transmission towers are excluded from this part.

R 408.10305 Definitions; A to F.

Rule 305. (1) "Allowable unit stress" means the maximum stress allowed to be applied as specified by recognized national codes and standards, such as the American national standards institute (ANSI), the American society of testing and materials

(ASTM), and the national fire protection association (NFPA).

- (2) **"Cage", "cage guard," or "basket guard"** means an enclosure fastened to the side rails of a fixed ladder or to the structure to encircle the climbing space of the ladder for the safety of a climber.
- (3) **"Cleats"** means a ladder's crosspieces which are rectangular cross sections placed on edge and on which an employee may step.
- (4) **"Design factor"** means the ratio of the ultimate failure strength of a member or piece of material or equipment to the actual working stress or intended safe load.
- (5) **"Fastenings"** means a device including a fixed, hinged, bearing, or slide-type fastening, for attaching a ladder to a structure, building, or equipment.
- (6) **"Fixed ladder"** means a ladder, including individual rung ladders, that is permanently attached to a structure, building, or equipment. The term does not include a ship's stairs or manhole steps.

R 408.10306 Definitions; G to M.

- Rule 306. (1) "Grab bar"** means a handhold placed adjacent to, or as an extension above, a ladder for the purpose of providing access beyond the limits of the ladder.
- (2) **"Individual rung ladder"** means a fixed ladder that has each rung individually attached to a structure, building, or equipment.
- (3) **"Ladder"** means an appliance which usually consists of 2 side rails joined at regular intervals by crosspieces called steps, rungs, or cleats and on which a person may step.
- (4) **"Ladder height"** means the distance from ground or floor level to the topmost landing or top of a ladder.
- (5) **"Ladder safety device"** means a device, other than a cage or well, designed to eliminate or reduce the possibility of accidental falls.
- (6) **"Manhole"** means an access through which an employee gains entry to a work area or to equipment below a surface or behind a vertical partition, such as a vessel wall.
- (7) **"Manhole steps"** means a series of steps individually attached or set into the walls of a manhole structure. Manhole steps are not considered to be an individual rung ladder.

R 408.10307 Definitions; P to R.

- Rule 307. (1) "Personal fall protection"** means a system which is worn by, or attached to, an employee and which is designed to prevent an employee from being injured if the employee falls while ascending or descending a ladder.
- (2) **"Pitch"** means the included angle which is between the horizontal and the ladder and which is measured on the opposite side of the ladder from the climbing side.
- (3) **"Platform"** means a work surface that is elevated above the surrounding work area.
- (4) **"Railings"** means any combination of railings defined in the general industry safety standards commission standard, Part 2. Floor and Wall Openings, Stairways and Skylights, being R 408.10201 et seq. of the Michigan Administrative Code.
- (5) **"Rail ladder"** means a fixed ladder which consists of side rails joined at regular intervals by rungs or cleats and which is fastened for its full length or in sections to a building, structure, or equipment.
- (6) **"Rungs"** means crosspieces which are circular or oval cross sections and on which an employee may step.

R 408.10308 Definitions; S to W.

- Rule 308. (1) "Side-step ladder"** means a ladder that requires an employee who gets off at the top to step sideways from the ladder to reach the landing.
- (2) **"Step bolt"** means a bolt or rung which is attached at intervals along a structural member and which is used for foot placement during climbing or standing. Step bolts are also referred to as "pole steps."
- (3) **"Steps"** means the flat crosspieces of a ladder on which an employee may step.
- (4) **"Through ladder"** means a ladder that requires an employee who gets off at the top to step through the ladder to reach the landing.
- (5) **"Tread"** means the horizontal member of a step.
- (6) **"Well"** means a permanent complete enclosure around a fixed ladder that protects a climber. Proper

clearance for a well will give same protection as a cage.

R 408.10310 Surface conditions and clearances.

- Rule 310. (1)** Fixed ladder surfaces shall be designed, constructed, and maintained to be free of recognized hazards that might result in death or serious injury to employees.
- (2) When fixed ladder surfaces cannot be maintained free of hazards such as snow, ice, or oil, employees shall be provided with a means to avoid or minimize their exposure to the hazards.

R 408.10311 Employee training; ladder use restrictions.

- Rule 311. (1)** An employer shall ensure that all employees who use ladders that have a working height of 6 feet (1.82 m) or more receive training on how to inspect ladders and how to properly use the ladders.
- (2) Ladders shall be used only for the purposes for which they were designed.

R 408.10321 Design.

Rule 321. A fixed ladder, its appurtenances and fastenings shall be designed to meet the following load requirements:

- (a) The minimum design live load shall be a single concentrated load of 300 pounds. A ladder installed before the effective date of this part may have a minimum design load of 200 pounds.
- (b) The number and position of additional concentrated live loads units of 300 pounds each, or 200 pounds each if installed before the effective date of this part, as determined from anticipated usage of the ladder shall be considered in the design.
- (c) The live loads shall be considered to be concentrated at the point or points causing the maximum stress in a structural member.
- (d) The weight of the ladder and appurtenances together with the live load shall be considered in the design of rails and fastenings.

R 408.10323 Rungs, cleats, and steps; spacing; maintenance; load requirements.

- Rule 323. (1)** The distance between rungs, cleats, and steps shall not be more than 12 inches from the top of one rung, cleat, or step to the top of the next rung, cleat, or step above and shall be uniformly spaced throughout the length of the ladder.
- (2) Rungs, cleats, and steps shall be free of splinters, sharp edges, burrs, and hazardous projections.
- (3) Each step or rung shall be capable of supporting, without deflection, at least a single concentrated load of 300 pounds (136.8 kg) applied in the middle of the step or rung.

R 408.10324 Rungs and cleats; length; design; diameter of metal rungs; construction of metal cleats; adoption by reference of standards for wood cleats and other wood components.

- Rule 324. (1)** The clear length of rungs and cleats shall be not less than 16 inches.
- (2) The rungs of an individual rung ladder shall be designed so that an employee's foot cannot slide off the end. See figure 1.
- (3) Metal rungs installed after November 15, 1971, shall have a diameter of not less than 3/4 of an inch and be constructed of steel rod or material of equivalent strength, except as provided in R 408.10341(1).

- (4) Metal cleats shall be made of steel or a material of equal strength and have a bearing surface that is not less than 1/2 of an inch.
- (5) Wood cleats and other wood components of a fixed ladder shall be as prescribed in ANSI standard A14.3-1984, fixed ladders, which is adopted by reference in these rules. The standard is available for inspection at the Lansing office of the department of consumer and industry services. The standard may be purchased from the American National Standards Institute, 11 West 42nd Street, New York, New York 10036, or from the Michigan Department of Consumer and Industry Services, MIOSHA Standards Division, 7150 Harris Drive, Box 30643, Lansing, Michigan 48909, at a cost as of the time of adoption of this rule of \$13.00.

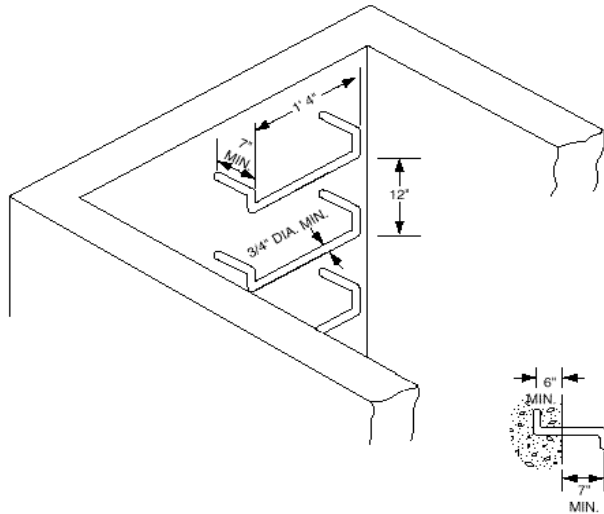

FIGURE 1
SUGGESTED DESIGN FOR RUNGS
ON INDIVIDUAL RUNG LADDER

R 408.10325 Side Rails.

Rule 325. A side rail which might be used as a climbing aid shall be of such cross section as to afford a gripping surface without sharp edges, splinters or burrs.

R 408.10326 Fastenings.

Rules 326. Fastenings shall be as strong as the rails and shall be sufficient length to allow a minimum distance, as required by rule 335, between a permanent structure and the rungs of a ladder. Fastenings shall be attached to the permanent structure either by being built into it or by through bolts, rivets or expansion bolts grouted, leaded or the equivalent.

R 408.10328 Splices.

Rule 328. A splice shall meet the design requirements specified in rule 321. A splice or connection shall have a smooth transition with the original members and shall not have sharp or extensive projections.

R 408.10331 Protection from deterioration.

- Rule 331. (1)** Dissimilar metals shall be protected from electrolytic action when they are joined.
- (2) A metal ladder and appurtenances installed in a corrosive environment shall be coated or otherwise treated to resist corrosion.
 - (3) A wood ladder subject to deterioration shall be treated with a transparent preservative. Paint shall not be used as a preservative. The design and construction shall prevent or minimize the accumulation of water on or between wood parts.

R 408.10333 Maintenance.

- Rule 333. (1)** A fixed ladder and any attached safety devices shall be inspected regularly. The inspection intervals shall be determined according to the use of the ladder and its exposure to deteriorating elements.
- (2) Rungs, cleats, side rails, and other appurtenances shall be maintained to withstand the minimum loads established by this part.
 - (3) A fixed ladder and any attached safety devices that are not in compliance with the requirements of this part shall be repaired or removed from service.
 - (4) Rungs, cleats, rails, and fasteners shall be maintained free of broken, worn, loose, or damaged parts that would create a falling hazard. Materials that are used to repair a rung, cleat, rail, or fastener shall be in compliance with the design strength of the rung, cleat, rail, or fastener.

R 408.10335 Clearance.

Rule 335. (1) The perpendicular distance from the center line of the rungs on the climbing side of a fixed ladder shall not be less than 36 inches for a pitch of 76 degrees, and not less than 30 inches for a pitch of 90 degrees to the nearest permanent object, except with respect to a cage or well installation. The minimum clearance for intermediate pitches between these 2 limits shall be in proportion to the slope. See figure 2.

FIGURE 2
CLEARANCE FOR UNAVOIDABLE OBSTRUCTION
AT REAR OF FIXED LADDER

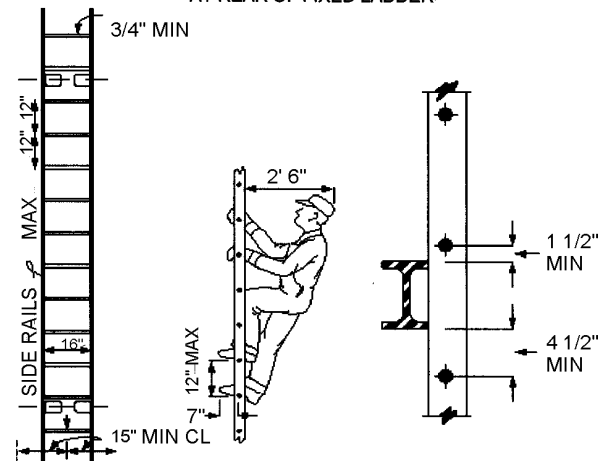

RAIL LADDER WITH BAR STEEL RAILS
AND ROUND STEEL RUNGS

- (2) A clear width of not less than 15 inches shall be provided each way from the center line of the fixed ladder to the nearest permanent object, except with respect to a cage or well installation.
- (3) The perpendicular distance from the center line of the rung on the back side of a fixed ladder to the nearest permanent object shall be not less than 7 inches, except that when an unavoidable object is encountered, the minimum clearances shown in figure 2 shall be followed.
- (4) The distance from the center line of a grab bar to the nearest permanent object in back of the grab bar shall be not less than 4 inches. A grab bar shall not protrude on the climbing side.
- (5) The step across distance from the nearest edge of a fixed ladder to equipment or a structure shall be not less than 2 1/2 inches nor more than 12 inches. See figure 3.

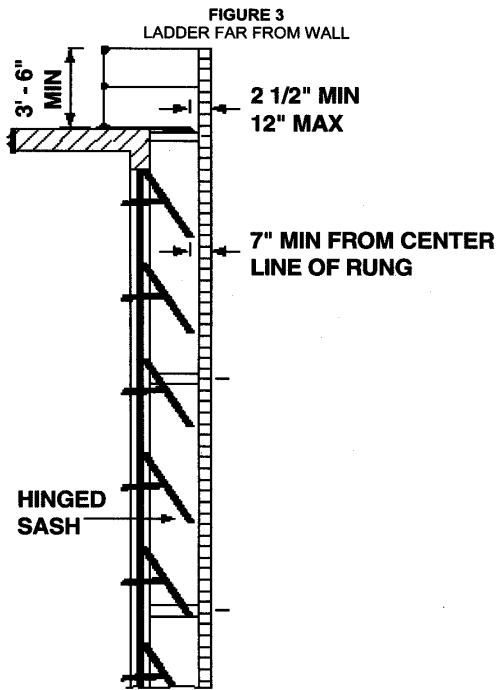

- (6) Where used, a counterweighted hatch cover shall open not less than 60 degrees from the horizontal. The distance from the center line of the rungs or cleats to the edge of the hatch opening on the climbing side shall be not less than 24 inches for offset walls or 30 inches for straight walls. Protruding potential hazards shall not be permitted within 24 inches of the center line of the rungs or cleats. Such hazards within 30 inches of the center line of the rungs or cleats shall be fitted with deflector plates placed at an angle of 60 degrees to the horizontal. (See figure 4). The relationship of a fixed ladder to a counter-weighted hatch cover shall be as prescribed in figure 5.

Figure 4
Deflector Plates For Head Hazards

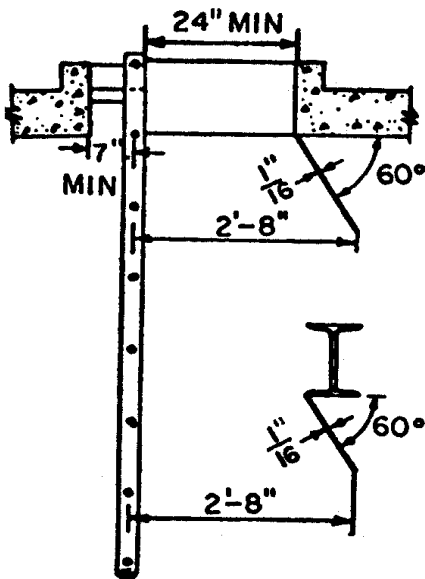
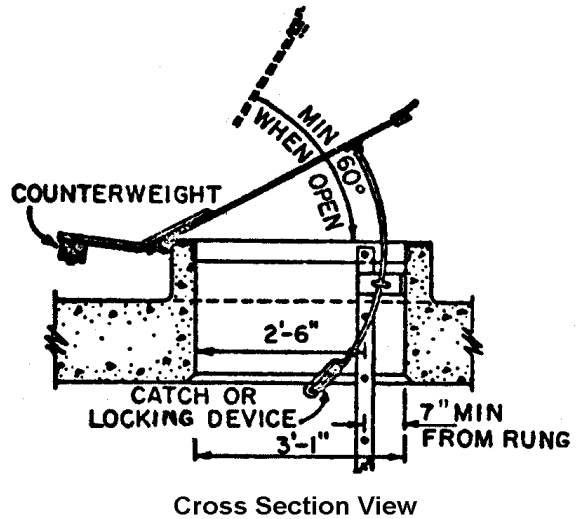

Figure 5
Relationship of Fixed Ladder
to a Safe Access Hatch



R 408.10341 Special rules for utility manhole fixed ladders.

Rule 341. (1) A utility manhole fixed ladder shall have:

- Rungs of not less than 3/4 inch diameter steel rod or material capable of supporting 300 pounds with not less than 10 inch clear length. Rungs existing before the effective date of this part may be 5/8 inch diameter steel rod or material of equal strength capable of supporting 200 pounds.
 - Rungs not less than 4 inches from the center of the rungs to the wall on the side opposite the climbing side. The rungs shall be embedded not less than 3 inches in the wall and aligned 1 above another.
 - Rungs not less than 27 inches from the center of the rungs to the wall or projections on the climbing side.
 - After November 15, 1971, rung configuration shall be so designed that an employee's foot cannot slide off the end. See figure 1.
 - Spacing between rungs of not more than 16 inches on center and uniformly spaced throughout the entire length.
- (2) A utility manhole with a conical shape shall not be provided with a fixed ladder. Access shall be by a portable ladder only.

R 408.10342 Step bolts and manhole steps; specifications.

Rule 342. (1) This rule applies to step bolts and manhole steps used on structures such as towers, stacks, conical manhole sections, and vaults. This rule does not apply to individual rung ladders.

- (2) Step bolts and manhole steps shall be continuous and spaced uniformly not less than 6 inches (15 cm) and not more than 18 inches (46 cm) apart.
- (3) The minimum clear step width of step bolts shall be 4 1/2 inches (11.4 cm). The minimum clear step width of manhole steps shall be 10 inches (25.4 cm).
- (4) The minimum toe clearance for manhole steps shall be 4 inches (11.1 cm) from the point of embedment on the wall to the outside face of the step. The toe clearance in the center of the manhole step shall be a minimum of 4 1/2 inches (11.4 cm) measured to the outside face of the step.
- (5) The minimum toe clearance for step bolts shall be 7 inches (17.8 cm). Where obstructions cannot be avoided, toe clearances may be reduced to 4 1/2 inches (11.4 cm).
- (6) Step bolts and manhole steps shall be designed to prevent an employee's foot from slipping or sliding off the end of the step bolt or manhole step.
- (7) Manhole steps and step bolts which are installed after the effective date of this rule and which are used in corrosive environments shall be constructed of, or coated with, a material that will retard corrosion of the step or bolt.
- (8) All manhole steps installed on or after the effective date of this rule shall be provided with slip-resistant surfaces, such as corrugated, knurled, or dimpled surfaces.
- (9) Each step bolt shall be capable of withstanding, without failure, not less than 4 times the intended load to be applied to the bolt.
- (10) Manhole steps installed before the effective date of this rule shall be capable of supporting their maximum intended load.

R 408.10345 Design of manhole steps.

Rule 345. (1) An employer shall ensure that manhole steps installed on or after the effective date of this rule are in compliance with all the following requirements:

- (a) The manhole steps shall be capable of withstanding, and remaining solidly secured after being subjected to, a separate application of a horizontal pull out load of 400 pounds (1,780 n), and a vertical load of 800 pounds (3,650 n).
- (b) The manhole steps shall be capable of sustaining the vertical test load without developing a permanent set of more than 1/2 of an inch (1.27 mm).
- (c) The loads shall be applied over a width of 3 1/2 inches (8.9 cm) centered on the step and be applied at a uniform rate until the required rate is reached.
- (d) There shall not be visible cracking or fracturing of the step or spalling of the concrete.

- (2) Step bolts and manhole steps shall be maintained in a safe condition and be visually inspected before each use.
- (3) Step bolts that are bent more than 15 degree below the horizontal shall be removed and replaced with bolts that are in compliance with the requirements of these rules. A manhole step that is bent to an extent that reduces the step's projection from the wall to less than 4 inches (10.1 cm) shall be removed and replaced with a step that is in compliance with the requirements of these rules or replaced with a climbing device that is in compliance with the requirements of this rule.

R 408.10351 Safety devices.

Rule 351. (1) A cage, well, or ladder safety device shall be provided on a ladder that is more than 20 feet (6.1 m) long and that rises to a unbroken length of not more than 30 feet (9.1 m).

- (2) A ladder safety device may be used on towers, water tanks, and chimney ladders that are more than 20 feet in unbroken length. The ladder safety device takes the place of cage protection. A landing is not required on a tower, water tank, or chimney ladder if a ladder safety device is used.
- (3) A ladder safety device, such as one that incorporates a life belt, friction brake, or sliding attachment, shall be in compliance with the design requirements of the ladder it serves.
- (4) Cages and wells that are provided for fixed ladders shall be designed to permit easy access to or egress from the ladders that they enclose. The cages and wells shall be continuous throughout the length of the fixed ladders, except for access, egress, and other transfer points. Cages and wells shall be designed and constructed to contain employees in the event of a fall and direct them to a lower landing.
- (5) Ladder surfaces shall be free of puncture or laceration hazards.

R 408.10352 Cages.

Rule 352. (1) A cage shall extend not less than 42 inches above the top of a landing, unless other approved protection is provided. See figure 6.

- (2) A cage shall extend down a ladder to a point not less than 7 feet nor more than 8 feet above the ground, floor or platform. The bottom shall be flaired not less than 4 inches or the part of the cage opposite the ladder shall be carried to the base.
- (3) A cage shall extend not less than 27 nor more than 28 inches from the center line of the rungs of a ladder. A cage shall be not less than 27 inches in width. The inside shall be clear of projections. Vertical bars shall be located at a spacing of not more than 40 degrees around the circumference of the cage, allowing a spacing of not more than approximately 9 1/2 inches center to center.

Figure 6
Cages for Ladders More Than 20 ft. High

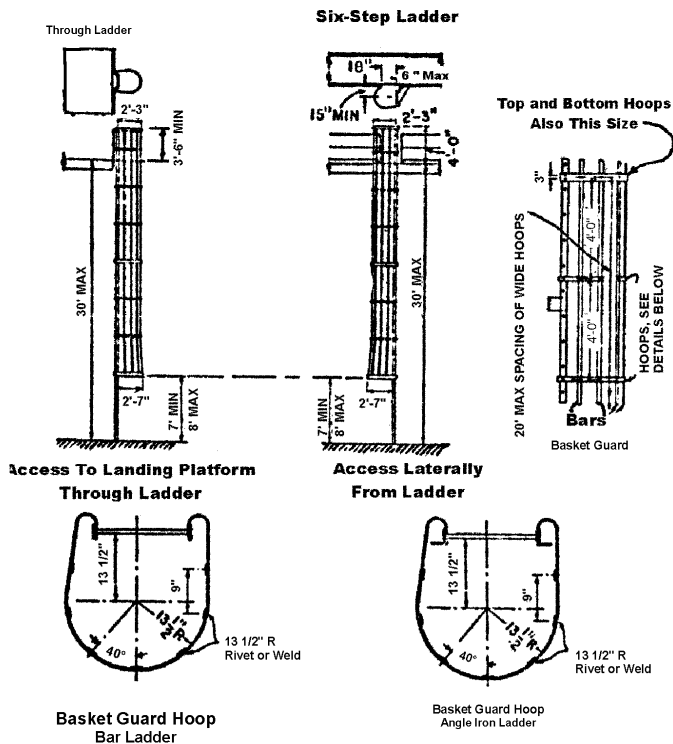

Cages - - Special Applications

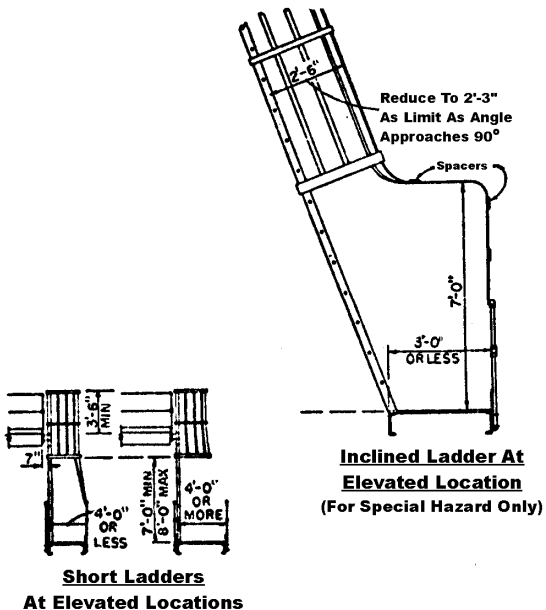

R 408.10353 Ladder wells.

Rule 353. A ladder well shall have a clear width of not less than 15 inches, measured each way from the center line of the ladder. On the climbing side of the ladder, not less than 30 inches of clearance shall be provided from the center line of the rungs to any obstruction, except not less than 27 inches from the center line of the rungs on the climbing side shall be provided for a smooth-walled well. See figure 7.

FIGURE 7
CLEARANCE DIAGRAM FOR FIXED LADDER IN WELL

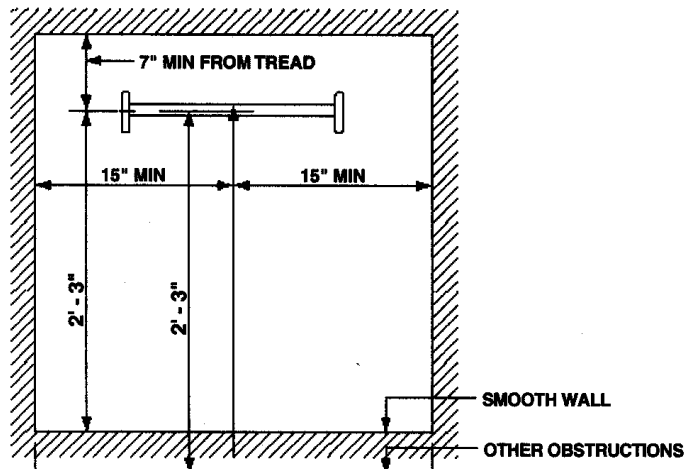

R 408.10354 Personal fall protection systems.

- Rule 354. (1)** If a personal fall protection system for climbing activities is used, it shall permit the employee who uses the system to ascend or descend without continually having to hold, push or pull any part of the system, leaving both hands free for climbing.
- (2)** The connection between carrier or lifeline and the point of attachment to a body belt or harness shall not be more than 9 inches (23 cm) in length.
- (3)** A personal fall protection system for climbing activities shall be activated within 2 feet (.61 m) after a fall occurs in order to limit the descending velocity of an employee to 7 feet/sec (2.1 m/sec) or less.
- (4)** Mountings for rigid carriers shall be attached to each end of the carrier and shall have intermediate mountings, as necessary, spaced along the entire length of the carrier to provide the strength necessary to stop employee falls.
- (5)** Mountings for flexible carriers shall be attached at each end of the carrier. When the system is exposed to wind, cable guides that utilize a flexible carrier shall be installed at a minimum spacing of 25 feet (7.6 m) and a maximum spacing of 40 feet (12.2 m) along the entire length of the carrier to prevent wind damage to the system.
- (6)** The design and installation of mountings and cable guides shall not reduce the design strength of the ladder.
- (7)** Ladder safety devices and their support systems shall be capable of withstanding, without failure, a drop test that consists of an 18-inch (.41 m) drop of a 500 pound (226 kg) weight.
- (8)** All other personal fall protection systems for climbing activities shall be capable of withstanding, without failure, a drop test that consists of a 4-foot (1.2 m) drop of a 250- pound (113 kg) weight.

R 408.10355 Landing platforms.

Rule 355. (1) A ladder used to ascend to a height of more than 20 feet, except on a chimney, without a ladder safety device shall have a landing platform for each 30 feet of ladder height; provided, however, that where a cage or well is not employed, a landing platform shall be provided for every 20 feet of height or fraction thereof. The requirements for a landing platform pursuant to this subrule and subrule (3) of

this rule may be satisfied by complying with the provisions of R 408.10351(2).

- (2) A ladder section shall be offset from the adjacent sections with a landing platform provided at each offset, except where the climbing space opening in the platform is closed with a hinged part of the platform. A landing platform shall be as specified in this rule, and be not less than 24 inches by 30 inches (61 cm by 76 cm), and have at least the same strength as the ladder.
- (3) Where an employee has to step a distance more than 12 inches from the center line of the rung of a ladder to the nearest edge of a structure or equipment, a landing platform shall be provided. The step-across distance shall be not less than 1 1/2 inches.
- (4) The side step from a fixed ladder to a platform shall be not less than 7 inches and not more than 12 inches measured from the side rail to the platform edge.
- (5) The side rail of an adjacent ladder shall be offset not less than 5 inches from the edge of a platform.
- (6) A landing platform shall be equipped with standard railings as specified in the general industry safety standards commission standard, Part 2. Floor and Wall Openings, Stairways and Skylights, being R 408.10201 to R 408.10241 of the Michigan Administrative Code arranged to give safe access to the ladder. A platform shall be not less than 24 inches in width and not less than 30 inches in length.
- (7) One rung of any section of a ladder shall be located at the level of the landing laterally served by the ladder. Where access to the landing is through the ladder, the same rung spacing as used on the ladder shall be used from the landing platform to the first rung below the landing.

R 408.10357 Ladder extensions.

- Rule 357. (1)** The side rails of a through or side-step ladder extension shall extend 3 1/2 feet above parapets and landings. On a through ladder extension, the rungs shall be omitted from the extension and shall have not less than 18 nor more than 24 inches clearance between rails. For sidestep or offset fixed ladder sections, at landings, the side rails and rungs shall be carried to the next regular rung beyond or above the 3 1/2 feet minimum. See figure 8.
- (2) This rule does not apply to a fixed ladder at a hatch cover.

**FIGURE 8
OFFSET FIXED LADDER
SECTIONS**

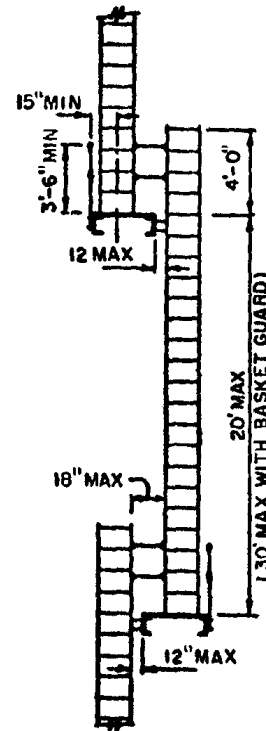

R 408.10361 Grab bars.

Rule 361. Grab bars shall be spaced by a continuation of the rung spacing when they are placed horizontally. Vertical grab bars shall have the same spacing as the ladder side rails. Grab bar diameters shall be the equivalent of the round rung diameters. This rule does not apply to a fixed ladder covered with a manhole cover to allow for traffic.

R 408.10365 Pitch.

- Rule 365. (1)** The preferred pitch of a fixed ladder shall be between 75 degrees and 90 degrees with the horizontal. (See figure 9.) However, a ladder with a pitch of less than 60 degrees shall have steps and raised hand rails, as specified in the general industry safety standards commission standard, Part 2. Floor and Wall Openings, Stairways and Skylights, being R 408.10201 to R 408.10241 of the Michigan Administrative Code.
- (2) A fixed ladder is substandard if it is installed within the substandard pitch range of 60 to 75 degrees with the horizontal. A substandard fixed ladder is permitted only where necessary to meet conditions of installation. (See figure 9.) This substandard pitch range shall be avoided, if possible.
 - (3) A ladder shall not have a pitch of more than 90 degrees with the horizontal.

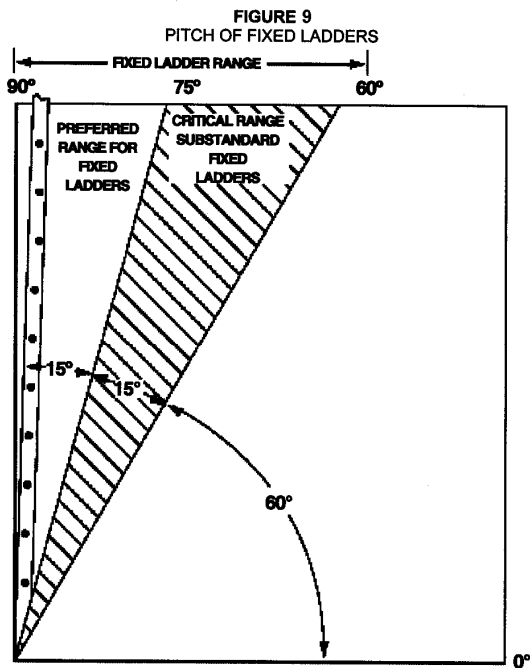

R 408.10371 Test methods for personal fall arrest systems.

Rule 371. The following sets forth test procedures for personal fall arrest systems as defined in the provisions of 29 C.F.R. §1910.129:

- (a) Lifelines, lanyards, and deceleration devices shall be attached to anchorage and connected to the body belt or body harness in the same manner as they would be when used to protect employees.
- (b) The anchorage shall be rigid and shall not have a deflection or more than .04 inches (1 mm) when a force of 2,250 pounds (10 kn) is applied.
- (c) The frequency response of the load measuring instrumentation shall be 120 hz.
- (d) The test weight used in the strength and force tests shall be a rigid, metal cylindrical or torso-shaped object that has a girth of 38 inches, plus or minus 4 inches (96 cm, plus or minus 10 cm).
- (e) The lanyard or lifeline used to create the free-fall distance shall be supplied with the system or, in its absence, the least elastic lanyard or lifeline available shall be used with the system.
- (f) The test weight for each test shall be hoisted to the required level and shall be quickly released without having any appreciable motion imparted to it.
- (g) The system's performance shall be evaluated, taking into account the range of environmental conditions for which it is designed to be used.
- (h) After the test, the system need not be capable of further operation.
- (i) During the testing of all systems, a test weight of 300 pounds, plus or minus 5 pounds (135 kg, plus or minus 2.5 kg), shall be used. (see subdivision (d) of this rule).
- (j) The test consists of dropping the test weight once. A new unused system shall be used for each test.
- (k) For a lanyard system, the lanyard length shall be 6 feet, plus or minus 2 inches (1.83 m, plus or minus 5 cm), as measured from the fixed anchorage to the attachment on the body belt or body harness.
- (l) For a rope-grab-type deceleration system, the length of the lifeline above the centerline of the grabbing mechanism to the lifeline's anchorage point shall not be more than 2 feet (0.61 m).

- (m) For a lanyard system, for a system that has a deceleration device which does not automatically limit the free-fall distance to 2 feet (0.61 m) or less, and for a system that has a deceleration device that has a connection distance of more than 1 foot (0.3 m), measured between the centerline of the lifeline and the attachment point to the body belt or harness, that the test weight shall be rigged to free-fall a distance of 7.5 feet (2.3 m) from the point that is 1.5 feet (46 cm) above the anchorage point to its hanging location (6 feet below the anchorage). The test weight shall fall without interference, obstruction, or hitting the floor or ground during the test. In some cases, a nonelastic wire lanyard of sufficient length may need to be added to the system, for test purposes, to create the necessary free-fall distance.
- (n) For a deceleration device system that has an integral lifeline or lanyard that automatically limits the free-fall distance to 2 feet (0.61 m) or less, the test weight shall be rigged to free-fall a distance of 4 feet (1.22 m).
- (o) Any weight that detaches from the belt or harness constitutes a failure of the strength test.
- (p) A force test consists of dropping the respective test weight specified in subdivision (q)(i) or (r)(i) of this rule once. A new, unused system shall be used for each test.
- (q) All of the following provisions apply to force tests for a lanyard system:
 - (i) A test weight of 220 pounds, plus or minus 3 pounds (100 kg, plus or minus 1.6 kg), shall be used. (See subdivision (d) of this rule).
 - (ii) Lanyard length shall be 6 feet, plus or minus 2 inches (1.83 m, plus or minus 5 cm), as measured from the fixed anchorage to the attachment on the body belt or body harness.
 - (iii) The test weight shall be fall-free from the anchorage level to its hanging location, a total of 6 feet (1.83 m) free fall-distance, without interference, obstruction, or hitting the floor or ground during the test.
- (r) Both of the following provisions apply to force tests for all systems other than a lanyard system:
 - (i) A test weight of 220 pounds, plus or minus 3 pounds (100 kg, plus or minus 1.6 kg), shall be used. (See subdivision (d) of this rule).
 - (ii) The free-fall distance to be used in the test shall be the maximum fall distance physically permitted by the system during normal use conditions, up to a maximum free-fall distance for the test weight of 6 feet (1.83 m), except as follows:
 - (a) For a deceleration system that has a connection link or lanyard, the test weight shall be a distance equal to the connection distance, which is the distance measured between the centerline of the lifeline and the attachment point to the body belt or harness.
 - (b) For a deceleration device system that has an integral lifeline or lanyard that automatically limits the free-fall distance to 2 feet (0.61 m) or less, the test weight shall free-fall a distance equal to that permitted by the system in normal use. For example, to test a system that has a self-retracting lifeline or lanyard, the test weight shall be supported and the system allowed to retract the lifeline or lanyard as

- it would in normal use. The test weight would then be released and the force and deceleration distance measured.
- (s) A system fails the force test if the recorded maximum arresting force is more than 1,260 pounds (15.6 kn) when using a body belt, or is more than 2,520 pounds (11.2 kn) when using a body harness.
 - (t) The maximum elongation and deceleration distance shall be recorded during the force test.
 - (u) All of the following provisions apply to deceleration device tests:
 - (i) A deceleration device shall be evaluated or tested under the environmental conditions, such as rain, ice, grease, dirt, or type of lifeline, for which the device is designed.
 - (ii) A rope-grab-type deceleration device shall be moved on a lifeline 1,000 times over the same length or line distance of not less than 1 foot (30.5 cm), and the mechanism shall lock each time unless the device is permanently marked to indicate the type of lifelines that must be used, several types of lifelines that have different diameters and different materials shall be used to test the device.

- (iii) The locking mechanism of self-activating-type deceleration devices that is designed for more than 1 arrest shall lock each of 1,000 times as it would in normal service.

R 408.10372 Test methods for positioning device systems.

Rule 372. The following provisions set forth test procedures for positioning device systems as defined in the provisions of 29 C.F.R. §1910.130:

- (a) The fixed anchorage shall be rigid and shall not have a deflection of more than .04 inches (.01 mm) when a force of 2,250 pounds (10 kn) is applied.
- (b) For lineman's body belts and pole straps, the body belt shall be secured to a 250-pound (113 kg) bag of sand at the point that simulates the waist of an employee. One end of the pole strap shall be attached to the rigid anchorage and the other end to the body belt. The sand bag shall be allowed to free-fall a distance of 4 feet (1.2 m). The pole strap and body belt fail testing if there is any breakage or slippage that permits the bag to fall-free to the ground.



Michigan Occupational Safety and Health Administration
PO Box 30643
Lansing, Michigan 48909-8143
Ph: 517.322.1845

The Department of Licensing and Regulatory Affairs will not discriminate against any individual or group because of race, sex, religion, age, national origin, color, marital status, disability, or political beliefs. Auxiliary aids, services and other reasonable accommodations are available upon request to individuals with disabilities.