



DEPARTMENT OF LICENSING AND REGULATORY AFFAIRS
DIRECTOR'S OFFICE
GENERAL INDUSTRY SAFETY STANDARDS

Filed with the Secretary of State on October 28, 1976 (as amended April 5, 1999)
These rules take effect 15 days after filing with the Secretary of State

(By authority conferred on the director of the department of consumer and industry services by sections 16 and 21 of Act No. 154 of the Public Acts of 1974, as amended and Executive Reorganization Order No. 1996-2, being §§408.1016, 408.1021, and 445.2001 of the Michigan Compiled Laws)

R 408.14923 of the Michigan Administrative Code is amended and R 408.14913 of the Code is rescinded as follows:

PART 49. SLINGS

TABLE OF CONTENTS

R 408.14901. Scope.....	1	R 408.14934. Wire rope slings; removal from service.....	5
R 408.14903. Definitions; A and B.....	1	R 408.14935. Wire rope slings; forming eyes.....	5
R 408.14904. Definitions; C.....	1	R 408.14941. Metal mesh slings; marking; rated capacity; coatings.....	12
R 408.14905. Definitions; D to H.....	2	R 408.14942. Metal mesh slings; attachment of handle.....	12
R 408.14906. Definitions; L and M.....	2	R 408.14943. Metal mesh slings; testing.....	12
R 408.14907. Definitions; P to R.....	3	R 408.14944. Metal mesh slings; use, temperature limits. .	12
R 408.14908. Definitions S to V.....	3	R 408.14945. Metal mesh slings; removal from service; repairs; records.....	13
R 408.14911. General operating practices.....	3	R 408.14951. Natural and synthetic fiber rope slings; rated capacity; diameter of curvature; temperature limits.	13
R 408.14912. Inspections generally; removal of sling from service.....	4	R 408.14952. Natural and synthetic fiber rope slings; splicing.....	13
R 408.14921. Alloy steel chain slings; identification.....	4	R 408.14953. Natural and synthetic fiber rope slings; end attachments.....	13
R 408.14922. Alloy steel chain slings; rated capacity of attachments.....	4	R 408.14954. Natural and synthetic fiber rope slings; removal from service; prohibition.....	13
R 408.14923. Alloy steel chain slings; inspections; records; removal from service; proof testing.....	4	R 408.14961. Synthetic web slings; marking or coding rated capacities.....	14
R 408.14924. Alloy steel chain slings; rated capacities, high temperature limit.....	4	R 408.14962. Synthetic web slings; webbing size and edges.....	14
R 408.14925. Alloy steel chain slings; repairing, reconditioning, and proof testing.....	4	R 408.14963. Synthetic web slings; fittings.....	14
R 408.14926. Alloy steel chain slings; cracked or deformed links or hooks; removal from service.....	4	R 408.14964. Synthetic web slings; rated capacity; use; temperature limits.....	14
R 408.14931. Wire rope slings; rated capacity; temperature limits.....	5	R 408.14965. Synthetic web slings; removal from service; repairs; certificate of proof test; prohibition.....	14
R 408.14932. Wire rope slings; minimum lengths.....	5		
R 408.14933. Wire rope slings; welded end attachment; certificate of proof test.....	5		

GENERAL PROVISIONS

R 408.14901. Scope.

Rule 4901. This part set forth the requirements for slings and their construction, care, and use in, around, and about a place of employment. Types of slings included in this part are: chain, wire rope, metal mesh, 3-strand natural or synthetic rope, and synthetic web made from nylon, polyester, and polypropylene.

R 408.14903. Definitions; A and B.

Rule 4903. (1) "Angle of loading" means the inclination of a leg or branch of a sling, measured from the horizontal or vertical plane as shown in Figure 5, provided that an angle of loading of 5 degrees or less from the vertical may be considered a vertical angle of loading.

(2) "Basket hitch" means a sling configuration whereby the sling is passed under the load and has both ends, end attachments, eyes, or handles on the hook or a single master link.

(3) "Braided wire rope" means a wire rope formed by plating component wire ropes.

(4) "Bridle wire rope sling" means a sling composed of multiple wire rope legs, with the top ends gathered in a fitting that goes over the lifting hook.

R 408.14904. Definitions; C.

Rule 4904. (1) "Cable laid endless sling-mechanical joint" means a wire rope sling made endlessly by joining the ends of a single length of cable laid rope with 1 or more metallic fittings.

(2) "Cable laid grommet-hand tucked" means an endless wire rope sling made from 1 length of rope wrapped 6 times around a core formed by hand, tucking the ends of the rope inside the 6 wraps.

(3) "Cable laid rope" means a wire rope composed of 6 wire ropes wrapped around a fiber or wire rope core.

(4) "Cable laid rope sling-mechanical joint" means a wire rope sling made from a cable laid rope, with eyes fabricated

by pressing or swaging 1 or more metal sleeves over the rope junction.

(5) "Choker hitch" means a sling configuration with 1 end of the sling passing under the load and through an end attachment, handle, or eye on the other end of the sling.

(6) "Coating" means an elastomer, or other suitable material, applied to a sling or to a sling component to impart desirable properties.

(7) "Cross rod" means a wire used to join spirals of metal mesh to form a complete fabric. (See Figure 2.)

R 408.14905. Definitions; D to H.

Rule 4905. (1) "Designated" means to be selected or assigned by the employer or the employer's representative as being qualified to perform specific duties.

(2) "Female handle of a choker sling" means a handle with a handle eye and a slot of such dimension as to permit passage of a male handle, thereby allowing the use of a metal mesh sling in a choker hitch. (See Figure 1.)

(3) "Handle" means a terminal fitting to which metal mesh fabric is attached. (See Figure 1.)

(4) "Handle eye" means an opening in a handle of a metal mesh sling shaped to accept a hook, shackle, or other lifting device. (See Figure 1.)

(5) "Hitch" means a sling configuration whereby the sling is fastened to an object or load, either directly to it or around it.

R 408.14906. Definitions; L and M.

Rule 4906. (1) "Link" means a single ring of a chain.

(2) "Male handle", sometimes called a "triangle," means a handle with a handle eye.

(3) "Master coupling link" means an alloy steel welded coupling link used as an intermediate link to join alloy steel chain to master links. (See Figure 3.)

(4) "Master link", sometimes called a "gathering ring," means a forged or welded steel link used to support all members (legs) of an alloy steel chain sling or wire rope sling. (See Figure 3.)

(5) "Mechanical coupling link" means a nonwelded, mechanically closed steel link used to attach master links and hooks to alloy steel chain.

(6) "Metal mesh, sometimes called fabric," means the flexible portion of a metal mesh sling, consisting of a series of transverse coils and cross rods.

**FIGURE 1
METAL MESH SLING (Typical)**

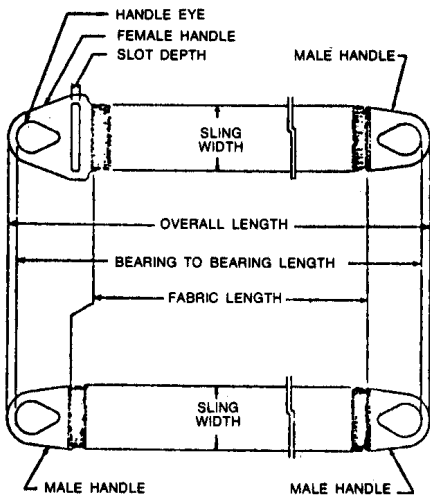

**FIGURE 2
METAL MESH CONSTRUCTION**

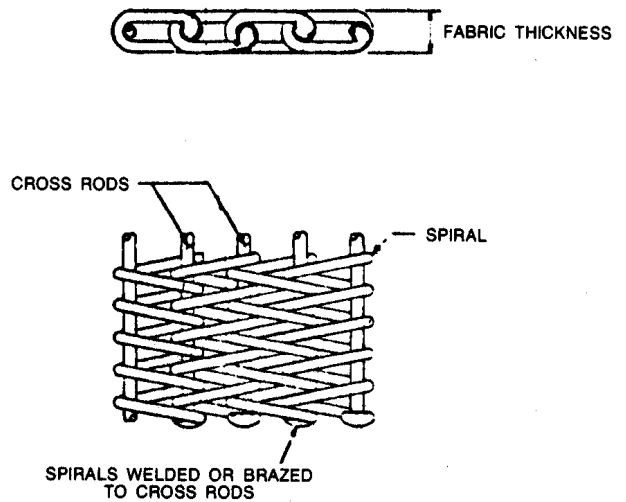

**FIGURE 3
MAJOR COMPONENTS OF QUADRUPLE SLING**

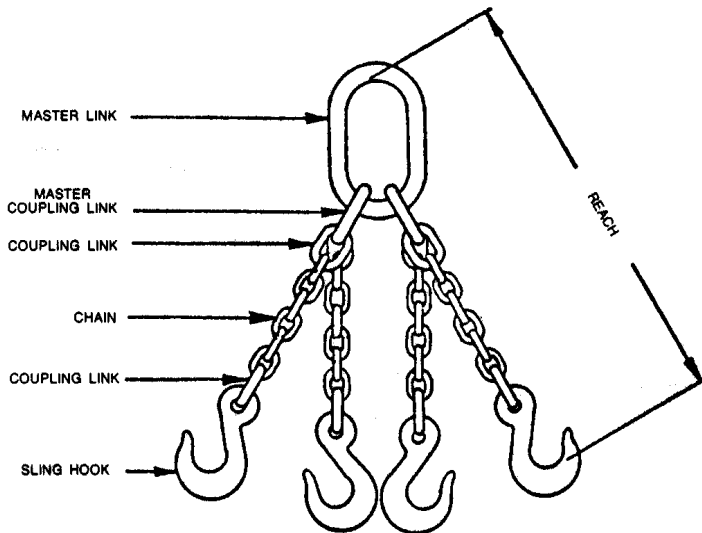
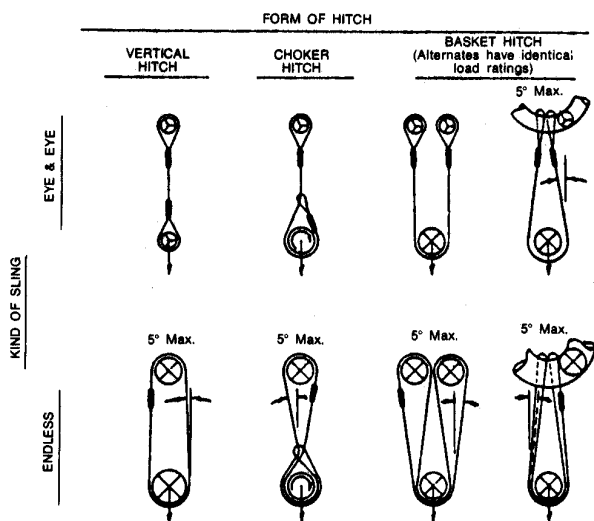

FIGURE 4
BASIC SLING CONFIGURATIONS WITH VERTICAL LEGS



NOTES: Angles 5 degrees or less from the vertical may be considered vertical angles.

For slings with legs more than 5 degrees off vertical, the actual angle as shown in Figure 5 must be considered.

EXPLANATION OF SYMBOLS: MINIMUM DIAMETER OF CURVATURE

- Represents a contact surface which shall have a diameter of curvature at least double the diameter of the rope from which the sling is made.
- Represents a contact surface which shall have a diameter of curvature at least 8 times the diameter of the rope.
- Represents a load in a choker hitch and illustrates the rotary force on the load and/or the slippage of the rope in contact with the load. Diameter of curvature of load surface shall be at least double the diameter of the rope.

R 408.14907. Definitions; P to R.

Rule 4907. (1) "Proof load" means a load applied in performance of a proof test.

(2) "Proof test" means a nondestructive tension test performed by the sling manufacturer, or an equivalent entity, to verify construction and workmanship of a sling.

(3) "Rated capacity" means the maximum working load permitted by the provisions of this part.

(4) "Reach" means the effective length of an alloy steel chain sling, measured from the top bearing surface of the upper terminal component to the bottom bearing surface of the lower terminal component.

R 408.14908. Definitions S to V.

Rule 4908. (1) "Selvage edge" means the finished edge of synthetic webbing designed to prevent unraveling.

(2) "Sling" means an assembly which connects the load to the material handling equipment for the purpose of lifting or hoisting.

(3) "Sling manufacturer" means a person or organization that assembles sling components into their final form for sale to users.

(4) "Spiral" means a single transverse coil that is the basic element from which metal mesh is fabricated. (See Figure 2.)

(5) "Strand laid endless sling-mechanical joint" means a wire rope sling made endless from 1 length of rope, with the ends joined by 1 or more metallic fittings.

(6) "Strand laid grommet-hand tucked" means an endless wire rope sling made from 1 length of strand wrapped 6 times around a core formed by hand tucking the ends of the strand inside the 6 wraps.

FIGURE 5
SLING CONFIGURATIONS WITH ANGLED LEGS

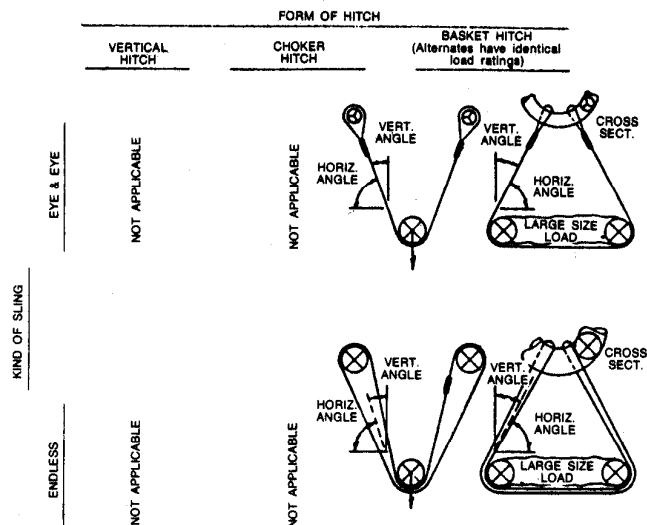

(7) "Strand laid rope" means a wire rope made with strands, usually 6 or 8, wrapped around a fiber core, wire strand core, or independent wire rope core.

(8) "Vertical hitch" means a method of supporting a load by a single, vertical part or leg of the sling. (See Figure 4.)

R 408.14911. General operating practices.

Rule 4911. Whenever a sling is used, the following practices shall be followed:

- (a) A damaged or defective sling, as described in this standard, shall not be used.
- (b) A sling shall not be shortened with bolts, knots, or other makeshift devices.
- (c) Sling legs shall not be kinked.
- (d) A sling shall not be loaded in excess of its rated capacity.
- (e) A sling used in a basket hitch shall have the load balanced to prevent slipping.
- (f) A sling shall be securely attached to its load.
- (g) A sling, other than an alloy steel chain, shall be padded or protected from the sharp corners of its load.
- (h) A suspended load shall be kept clear of all obstructions.
- (i) An employee shall be kept clear of a suspended load and a load about to be lifted.
- (j) An employee's hand or finger shall not be placed between the load and sling while the sling is being tightened.
- (k) Slack in a sling shall be removed gradually.
- (l) A sling shall not be pulled from under a load when the load is resting on the sling.

R 408.14912. Inspections generally; removal of sling from service.

Rule 4912. (1) A sling and all fastenings shall be inspected for damage and defects by a designated employee before each day's use.

(2) Where service conditions warrant, additional inspections shall be performed during sling use.

(3) A damaged or defective sling, as described in this part, shall be immediately removed from service.

R 408.14913. Rescinded.**ALLOY STEEL CHAIN SLINGS****R 408.14921. Alloy steel chain slings; identification.**

Rule 4921. An alloy steel chain sling shall have a permanently affixed, durable identification, stating the size, grade, rated capacity, and reach.

R 408.14922. Alloy steel chain slings; rated capacity of attachments.

Rule 4922. (1) A hook, ring, oblong link, pear-shaped link, welded or mechanical coupling link, or other attachment shall have a rated capacity at least equal to that of the alloy steel chain with which they are used, or the sling shall not be used in excess of the rated capacity of the weakest component.

(2) A makeshift link or fastener formed from bolts or rods, or other such attachments, shall not be used.

R 408.14923. Alloy steel chain slings; inspections; records; removal from service; proof testing.

Rule 4923. (1) In addition to the inspection prescribed by R 408.14912, an employer shall designate an employee to make a thorough periodic inspection of an alloy steel chain sling in use on a regular basis. An employer shall determine the regularity of inspection based on all of the following factors:

- (a) Frequency of sling use.
- (b) Severity of service conditions.
- (c) Nature of lifts being made.
- (d) Experience gained on the service life of slings used in similar circumstances. The designated employee shall inspect an alloy steel chain sling at least once every 12 months.

(2) The employer shall make and maintain a record of the most recent month in which each alloy steel chain sling was thoroughly inspected and shall make the record available for examination.

(3) The employee designated to make the inspection of an alloy steel chain sling shall make a thorough inspection for all of the following:

- (a) Wear.
- (b) Defective welds.
- (c) Deformation.
- (d) An increase in length beyond acceptable limits established in this part. If the defects or deteriorations are present, then the designated employee shall immediately remove the sling from service.

(4) The employer shall ensure that, before use, each new, repaired, or reconditioned alloy steel chain sling, including all welded components in the sling assembly, is proof-tested by the sling manufacturer in accordance with ANSI/ASME standard B-30.9-1990, slings. The standard is adopted by reference in these rules and may be inspected at

the Lansing office of the Michigan Department of Consumer and Industry Services. The standard may be purchased at a cost of \$90.00 as of time of adoption of this rule from the American National Standards Institute, 1430 Broadway Avenue, New York, New York 10018, or the Michigan Department of Consumer and Industry Services, State Secondary Complex, 7150 Harris Drive, Box 30643, Lansing, Michigan 48909. The employer shall retain a certificate of the proof test and shall make it available for examination.

(5) If the chain size at any point of any link is less than that prescribed in Table 1, then the designated employee shall remove the sling from service.

TABLE 1
MINIMUM ALLOWABLE CHAIN SIZE
AT ANY POINT OF LINK

Chain size (inches)	Maximum allowable wear
1/4	13/64
3/8	19/64
1/2	25/64
5/8	31/64
3/4	19/32
7/8	45/64
1	13/16
1 1/8	29/32
1 1/4	1
1 3/8	1-3/32
1 1/2	1-3/16
1 3/4	1-13/32

R 408.14924. Alloy steel chain slings; rated capacities, high temperature limit.

Rule 4924. (1) An alloy steel chain sling shall not be used with a load in excess of the rated capacities prescribed in Table 2. A sling not included in this table shall be used only in accordance with manufacturer's recommendations.

(2) An alloy steel chain sling shall be permanently removed from service if it is heated above 1,000 degrees Fahrenheit. When exposed to a service temperature of more than 600 degrees Fahrenheit, the maximum working load limit permitted in Table 2 shall be reduced in accordance with the manufacturer's recommendations.

R 408.14925. Alloy steel chain slings; repairing, reconditioning, and proof testing.

Rule 4925. (1) A worn or damaged alloy steel chain sling or attachment shall not be used until repaired.

(2) When welding or heat treating is performed, a sling shall not be used unless repaired, reconditioned, and proof tested by the sling manufacturer.

(3) A mechanical coupling link or low carbon steel repair link shall not be used to repair broken lengths of chain.

R 408.14926. Alloy steel chain slings; cracked or deformed links or hooks; removal from service.

Rule 4926. (1) Alloy steel chain slings with cracked or deformed master links, coupling links, or other components shall be removed from service.

(2) A sling shall be removed from service if the hook is cracked, has been opened more than 15% of the normal throat opening measured at the narrowest point, or twisted more than 10 degrees from the plane of the unbent hook.

TABLE 2
RATED CAPACITY (WORKING LOAD LIMIT), FOR ALLOY STEEL CHAIN SLINGS
RATED CAPACITY (WORKING LOAD LIMIT), POUNDS

CHAIN SIZE, INCHES	SINGLE BRANCH SLING- 90 DEGREE LOADING	DOUBLE SLING VERTICLE ANGLE (1)			TRIPLE AND QUADRUPLE SLING(3) VERTICLE ANGLE (1)		
		30 DEGREE	45 DEGREE	60 DEGREE	30 DEGREE	45 DEGREE	60 DEGREE
		HORIZONTAL ANGLE (2)			HORIZONTAL ANGLE (2)		
		60 DEGREE	45 DEGREE	30 DEGREE	60 DEGREE	45 DEGREE	30 DEGREE
1/4	3,250	5,550	4,550	3,250	8,400	6,800	4,900
3/8	6,600	11,400	9,300	6,600	17,000	14,000	9,900
1/2	11,250	19,500	15,900	11,250	29,000	24,000	17,000
5/8	16,500	28,500	23,300	16,500	43,000	35,000	24,500
3/4	23,000	39,800	32,500	23,000	59,500	48,500	34,500
7/8	28,750	49,800	40,600	28,750	74,500	61,000	43,000
1	38,750	67,100	54,800	38,750	101,000	82,000	58,000
1-1/8	44,500	77,000	63,000	44,500	115,300	94,500	66,500
1-1/4	57,500	99,500	81,000	57,500	149,000	121,500	86,000
1-3/8	67,000	116,000	94,000	67,000	174,000	141,000	100,500
1-1/2	80,000	138,000	112,500	80,000	207,000	169,000	119,500
1-3/4	100,000	172,000	140,000	100,000	258,000	210,000	150,000

(1) Rating of multileg slings adjusted for angle of loading measured as the included angle between the inclined leg and the vertical.

(2) Rating of multileg slings adjusted for angle of loading between the inclined leg and the horizontal plane of the load.

(3) Quadruple sling rating is same as triple sling because normal lifting practice may not distribute load uniformly to all 4 legs.

WIRE ROPE SLINGS

R 408.14931. Wire rope slings; rated capacity; temperature limits.

Rule 4931. (1) A wire rope sling shall not be used with loads in excess of the rated capacities shown in Tables 3 to 14. A sling not included in these tables shall be used only in accordance with the manufacturer's recommendations.

(2) A fiber core wire rope sling of any grade shall be permanently removed from service if it is exposed to a temperature in excess of 200 degrees Fahrenheit.

(3) When a nonfiber core wire rope sling of any grade is used at a temperature above 400 degrees Fahrenheit or below minus 60 degrees Fahrenheit, recommendations of the sling manufacturer regarding use at that temperature shall be followed.

R 408.14932. Wire rope slings; minimum lengths.

Rule 4932. (1) Cable laid and a 6 x 19 and 6 x 37 sling shall have a minimum clear length of wire rope 10 times the component rope diameter between splices, sleeves, or end fittings.

(2) A braided sling shall have a minimum clear length of wire rope 40 times the component rope diameter between the loops or end fittings.

(3) A cable laid grommet, strand laid grommet, and endless sling shall have a minimum circumferential length of 96 times their body diameter.

R 408.14933. Wire rope slings; welded end attachment; certificate of proof test.

Rule 4933. (1) Welding of an end attachment, except covers to thimbles, shall be performed prior to the assembly of the sling.

(2) All welded end attachments shall not be used unless proof tested by the manufacturer at twice their rated capacity prior to initial use. The employer shall retain a certificate of the proof test, and make it available for examination.

R 408.14934. Wire rope slings; removal from service.



Rule 4934. A wire rope sling shall be removed from service if any of the following conditions are present:

- Ten randomly distributed broken wires in 1 rope lay, or 5 broken wires in 1 strand in 1 rope lay.
- Wear or scraping of 1/3 the original diameter of outside individual wires.
- Kinking, crushing, bird caging, or any other damage resulting in distortion of the wire rope structure.
- Evidence of heat damage.
- End attachments that are cracked, deformed, or worn.
- Hooks that have been opened more than 15% of the normal throat opening measured at the narrowest point, or twisted more than 10 degrees from the plane of the unbent hook.
- Corrosion of the rope or end attachments.

R 408.14935. Wire rope slings; forming eyes.

Rule 4935. An eye in a wire rope sling shall not be formed by using a knot or a wire rope clip.

TABLE 3
RATED CAPACITIES FOR SINGLE LEG SLINGS
6x19 and 6x37 Classification Improved Plow Steel Grade Rope with Fiber Core (FC)

Rope		Rated capacities, tons (2,000 lb.)								
		 Vertical			 Choker			 Vertical basket *		
Diameter (inches)	Construction	HT	MS	S	HT	MS	S	HT	MS	S
1/4	6 x 19	0.49	0.51	0.55	0.37	0.38	0.41	0.99	1.0	1.1
5/16	6 x 19	0.76	0.79	0.85	0.57	0.59	0.64	1.5	1.6	1.7
3/8	6 x 19	1.1	1.1	1.2	0.80	0.85	0.91	2.1	2.2	2.4
7/16	6 x 19	1.4	1.5	1.6	1.1	1.1	1.2	2.9	3.0	3.3
1/2	6 x 19	1.8	2.0	2.1	1.4	1.5	1.6	3.7	3.9	4.3
9/16	6 x 19	2.3	2.5	2.7	1.7	1.9	2.0	4.6	5.0	5.4
5/8	6 x 19	2.8	3.1	3.3	2.1	2.3	2.5	5.6	6.2	6.7
3/4	6 x 19	3.9	4.4	4.8	2.9	3.3	3.6	7.8	8.8	9.5
7/8	6 x 19	5.1	5.9	6.4	3.9	4.5	4.8	10.0	12.0	13.0
1	6 x 19	6.7	7.7	8.4	5.0	5.8	6.3	13.0	15.0	17.0
1 1/8	6 x 19	8.4	9.5	10.0	6.3	7.1	7.9	17.0	19.0	21.0
1 1/4	6 x 37	9.8	11.0	12.0	7.4	8.3	9.2	20.0	22.0	25.0
1 3/8	6 x 37	12.0	13.0	15.0	8.9	10.0	11.0	24.0	27.0	30.0
1 1/2	6 x 37	14.0	16.0	17.0	10.0	12.0	13.0	28.0	32.0	35.0
1 5/8	6 x 37	16.0	18.0	21.0	12.0	14.0	15.0	33.0	37.0	41.0
1 3/4	6 x 37	19.0	21.0	24.0	14.0	16.0	18.0	38.0	43.0	48.0
2	6 x 37	25.0	28.0	31.0	18.0	21.0	23.0	49.0	55.0	62.0

HT=Hand Tucked Splice and Hidden Tuck Splice. For hidden tuck splice (IWRC) use values in HT columns.

MS=Mechanical Splice.



S=Swaged or Zinc Poured Socket.

* These values only apply when the D/d ratio for HT slings is 10 or greater, and for MS and S Slings is 20 or greater where:

D=Diameter of curvature around which the body of the sling is bent.

d=Diameter of rope.

TABLE H-4
RATED CAPACITIES FOR SINGLE LEG SLINGS
6x19 and 6x37 Classification Improved Plow Steel Grade Rope with Independent Wire Core (IWRC)

Rope		Rated capacities, tons (2,000 lb.)								
		 Vertical			 Choker			 Vertical basket ¹		
Diameter (inches)	Construction	HT	MS	S	HT	MS	S	HT	MS	S
1/4	6 x 19	0.53	0.56	0.59	0.40	0.42	0.44	1.0	1.1	1.2
5/16	6 x 19	0.81	0.87	0.92	0.61	0.65	0.69	1.6	1.7	1.8
3/8	6 x 19	1.1	1.2	1.3	0.86	0.93	0.98	2.3	2.5	2.6
7/16	6 x 19	1.5	1.7	1.8	1.2	1.3	1.3	3.1	3.4	3.5
1/2	6 x 19	2.0	2.2	2.3	1.5	1.6	1.7	3.9	4.4	4.6
9/16	6 x 19	2.5	2.7	2.9	1.8	2.1	2.2	4.9	5.5	5.8
5/8	6 x 19	3.0	3.4	3.6	2.2	2.5	2.7	6.0	6.8	7.2
3/4	6 x 19	4.2	4.9	5.1	3.1	3.6	3.8	8.4	9.7	10.0
7/8	6 x 19	5.5	6.6	6.9	4.1	4.9	5.2	11.0	13.0	14.0
1	6 x 19	7.2	8.5	9.0	5.4	6.4	6.7	14.0	17.0	18.0
1 1/8	6 x 19	9.0	10.0	11.0	6.8	7.8	8.5	18.0	21.0	23.0
1 1/4	6 x 37	10.0	12.0	13.0	7.9	9.2	9.9	21.0	24.0	26.0
1 3/8	6 x 37	13.0	15.0	16.0	9.6	11.0	12.0	25.0	29.0	32.0
1 1/2	6 x 37	15.0	17.0	19.0	11.0	13.0	14.0	30.0	35.0	38.0
1 5/8	6 x 37	18.0	20.0	22.0	13.0	15.0	17.0	35.0	41.0	44.0
1 3/4	6 x 37	20.0	24.0	26.0	15.0	18.0	19.0	41.0	47.0	51.0
2	6 x 37	26.0	30.0	33.0	20.0	23.0	25.0	53.0	61.0	66.0

¹ These values only apply when the D/d ratio for HT slings is 10 or greater, and for MS and S Slings is 20 or greater where:

D=Diameter of curvature around which the body of the sling is bent.



d=Diameter of rope.

HT=Hand Tucked Splice: For hidden tuck splice (IWRC) use Table H-3 values in HT column.

MS=Mechanical Splice.

S=Swaged or Zinc Poured Socket.

TABLE H-5
RATED CAPACITIES FOR SINGLE LEG SLINGS
Cable Laid Rope—Mechanical Splice Only
7x7x7 and 7x7x19 Classification Galvanized Aircraft Grade Rope
7x6x19 IWRC Construction Improved Plow Steel Grade Rope



Rope		Rated capacities, tons (2,000 lb.)		
Diameter (inches)	Construction			
		Vertical	Choker	Vertical basket ¹
1/4	7x7x7	0.50	0.38	1.0
3/8	7x7x7	1.1	0.81	2.2
1/2	7x7x7	1.8	1.4	3.7
5/8	7x7x7	2.8	2.1	5.5
3/4	7x7x7	3.8	2.9	7.6
5/8	7x7x19	2.9	2.2	5.8
3/4	7x7x19	4.1	3.0	8.1
7/8	7x7x19	5.4	4.0	11.0
1	7x7x19	6.9	5.1	14.0
1 1/8	7x7x19	8.2	6.2	16.0
1 1/4	7x7x19	9.9	7.4	20.0
3/4	² 7x6x19	3.8	2.8	7.6
7/8	² 7x6x19	5.0	3.8	10.0
1	² 7x6x19	6.4	4.8	13.0
1 1/8	² 7x6x19	7.7	5.8	15.0
1 1/4	² 7x6x19	9.2	6.9	18.0
1 5/16	² 7x6x19	10.0	7.5	20.0
1 3/8	² 7x6x19	11.0	8.2	22.0
1 1/2	² 7x6x19	13.0	9.6	26.0

¹ These values only apply when the D/d ratio is 10 or greater where:
D=Diameter of curvature around which the body of the sling is bent.

d=Diameter of rope.

² IWRC.

TABLE H-6
RATED CAPACITIES FOR SINGLE LEG SLINGS
8-Part and 6-Part Braided Rope
6x7 and 6x19 Classification Improved Plow Steel Grade Rope
7x7 Construction Galvanized Aircraft Grade Rope

Component Ropes		Rated capacities, tons (2,000 lb.)					
Diameter (inches)	Construction						
		Vertical		Choker		Basket Vertical to 30° ¹	
		8-Part	6-Part	8-Part	6-Part	8-Part	6-Part
3/32	6x7	0.42	0.32	0.32	0.24	0.74	0.55
1/8	6x7	0.76	0.57	0.57	0.42	1.3	0.96
3/16	6x7	1.7	1.3	1.3	0.94	2.9	2.2
3/32	7x7	0.51	0.39	0.38	0.29	0.89	0.67
1/8	7x7	0.95	0.71	0.71	0.53	1.6	1.2
3/16	7x7	2.1	1.5	1.5	1.2	3.6	2.7
3/16	6x19	1.7	1.3	1.3	0.98	3.0	2.2
1/4	6x19	3.1	2.3	2.3	1.7	5.3	4.0
5/16	6x19	4.8	3.6	3.6	2.7	8.3	6.2
3/8	6x19	6.8	5.1	5.1	3.8	12.0	8.9
7/16	6x19	9.3	6.9	6.9	5.2	16.0	12.0
1/2	6x19	12.0	9.0	9.0	6.7	21.0	15.0
9/16	6x19	15.0	11.0	11.0	8.5	26.0	20.0
5/8	6x19	19.0	14.0	14.0	10.0	32.0	24.0
3/4	6x19	27.0	20.0	20.0	15.0	46.0	35.0
7/8	6x19	36.0	27.0	27.0	20.0	62.0	47.0
1	6x19	47.0	35.0	35.0	26.0	81.0	61.0

¹ These values only apply when the D/d ratio is 20 or greater where:

D=Diameter of curvature around which the body of the sling is bent.

d=Diameter of component rope.

TABLE H-7
RATED CAPACITIES FOR 2-LEG AND 3-LEG BRIDLE SLINGS
6x19 and 6x37 Classification Improved Plow Steel Grade Rope With Fiber Core (FC)

Rope		Rated Capacities, Tons (2,000 pounds)											
Diameter (inches)	Construction	2-leg Bridle Slings						3-leg Bridle Slings					
		30° ¹ (60°) ²		45° angle		60° ¹ (30°) ²		30° ¹ (60°) ²		45° angle		60° ¹ (30°) ²	
		HT	MS	HT	MS	HT	MS	HT	MS	HT	MS	HT	MS
1/4	6x19	0.85	0.88	0.70	0.72	0.49	0.51	1.3	1.3	1.0	1.1	0.74	0.76
5/16	6x19	1.3	1.4	1.1	1.1	0.76	0.79	2.0	2.0	1.6	1.7	1.1	1.2
3/8	6x19	1.8	1.9	1.5	1.6	1.1	1.1	2.8	2.9	2.3	2.4	1.6	1.7
7/16	6x19	2.5	2.6	2.0	2.2	1.4	1.5	3.7	4.0	3.0	3.2	2.1	2.3
1/2	6x19	3.2	3.4	2.6	2.8	1.8	2.0	4.8	5.1	3.9	4.2	2.8	3.0
9/16	6x19	4.0	4.3	3.2	3.5	2.3	2.5	6.0	6.5	4.9	5.3	3.4	3.7
5/8	6x19	4.8	5.3	4.0	4.4	2.8	3.1	7.3	8.0	5.9	6.5	4.2	4.6
3/4	6x19	6.8	7.6	5.5	6.2	3.9	4.4	10.0	11.0	8.3	9.3	5.8	6.6
7/8	6x19	8.9	10.0	7.3	8.4	5.1	5.9	13.0	15.0	11.0	13.0	7.7	8.9
1	6x19	11.0	13.0	9.4	11.0	6.7	7.7	17.0	20.0	14.0	16.0	10.0	11.0
1 1/8	6x19	14.0	16.0	12.0	13.0	8.4	9.5	22.0	24.0	18.0	20.0	13.0	14.0
1 1/4	6x37	17.0	19.0	14.0	16.0	9.8	11.0	25.0	29.0	21.0	23.0	15.0	17.0
1 3/8	6x37	20.0	23.0	17.0	19.0	12.0	13.0	31.0	35.0	25.0	28.0	18.0	20.0
1 1/2	6x37	24.0	27.0	20.0	22.0	14.0	16.0	36.0	41.0	30.0	33.0	21.0	24.0
1 5/8	6x37	28.0	32.0	23.0	26.0	16.0	18.0	43.0	48.0	35.0	39.0	25.0	28.0
1 3/4	6x37	33.0	37.0	27.0	30.0	19.0	21.0	49.0	56.0	40.0	45.0	28.0	32.0
2	6x37	43.0	48.0	35.0	39.0	25.0	28.0	64.0	72.0	52.0	59.0	37.0	41.0

HT=Hand Tucked Splice.

MS=Mechanical Splice.

¹ Vertical Angles.² Horizontal Angles.

TABLE H-8
RATED CAPACITIES FOR 2-LEG AND 3-LEG BRIDLE SLINGS
6x19 and 6x37 Classification Improved Plow Steel Grade Rope With Independent Wire Rope Core (IWRC)

Rope		Rated Capacities, Tons (2,000 pounds)											
Diameter (inches)	Construction	2-leg Bridle Slings						3-leg Bridle Slings					
		30° ¹ (60°) ²		45° angle		60° ¹ (30°) ²		30° ¹ (60°) ²		45° angle		60° ¹ (30°) ²	
		HT	MS	HT	MS	HT	MS	HT	MS	HT	MS	HT	MS
1/4	6x19	0.92	0.97	0.75	0.79	0.53	0.56	1.4	1.4	1.1	1.2	0.79	0.84
5/16	6x19	1.4	1.5	1.1	1.2	0.81	0.87	2.1	2.3	1.7	1.8	1.2	1.3
3/8	6x19	2.0	2.1	1.6	1.8	1.1	1.2	3.0	3.2	2.4	2.6	1.7	1.9
7/16	6x19	2.7	2.9	2.2	2.4	1.5	1.7	4.0	4.4	3.3	3.6	2.3	2.5
1/2	6x19	3.4	3.8	2.8	3.1	2.0	2.2	5.1	5.7	4.2	4.6	3.0	3.3
9/16	6x19	4.3	4.8	3.5	3.9	2.5	2.7	6.4	7.1	5.2	5.8	3.7	4.1
5/8	6x19	5.2	5.9	4.2	4.8	3.0	3.4	7.8	8.8	6.4	7.2	4.5	5.1
3/4	6x19	7.3	8.4	5.9	6.9	4.2	4.9	11.0	13.0	8.9	10.0	6.3	7.3
7/8	6x19	9.6	11.0	7.8	9.3	5.5	6.6	14.0	17.0	12.0	14.0	8.3	9.9
1	6x19	12.0	15.0	10.0	12.0	7.2	8.5	19.0	22.0	15.0	18.0	11.0	13.0
1 1/8	6x19	16.0	18.0	13.0	15.0	9.0	10.0	23.0	27.0	19.0	22.0	13.0	16.0
1 1/4	6x37	18.0	21.0	15.0	17.0	10.0	12.0	27.0	32.0	22.0	26.0	16.0	18.0
1 3/8	6x37	22.0	25.0	18.0	21.0	13.0	15.0	33.0	38.0	27.0	31.0	19.0	22.0
1 1/2	6x37	26.0	30.0	21.0	25.0	15.0	17.0	39.0	45.0	32.0	37.0	23.0	26.0
1 5/8	6x37	31.0	35.0	25.0	29.0	18.0	20.0	46.0	53.0	38.0	43.0	27.0	31.0
1 3/4	6x37	35.0	41.0	29.0	33.0	20.0	24.0	53.0	61.0	43.0	50.0	31.0	35.0
2	6x37	46.0	53.0	37.0	43.0	26.0	30.0	68.0	79.0	56.0	65.0	40.0	46.0

HT=Hand Tucked Splice.

MS=Mechanical Splice.

¹ Vertical Angles.² Horizontal Angles.



TABLE H-9
RATED CAPACITIES FOR 2-LEG AND 3-LEG BRIDLE SLINGS
Cable Laid Rope---Mechanical Splice Only
7x7x7 and 7x7x19 Construction Galvanized Aircraft Grade Rope
7x6x19 IWRC Construction Improved Plow Steel Grade Rope

Rope		Rated Capacities, Tons (2,000 pounds)					
Diameter (inches)	Construction	2-leg Bridle Slings			3-leg Bridle Slings		
		30° (60°)	45° angle	60° (30°)	30° (60°)	45° angle	60° (30°)
1/4	7x7x7	0.87	0.71	0.50	1.3	1.1	0.75
3/8	7x7x7	1.9	1.5	1.1	2.8	2.3	1.6
1/2	7x7x7	3.2	2.6	1.8	4.8	3.9	2.8
5/8	7x7x7	4.8	3.9	2.8	7.2	5.9	4.2
3/4	7x7x7	6.6	5.4	3.8	9.9	8.1	5.7
5/8	7x7x19	5.0	4.1	2.9	7.5	6.1	4.3
3/4	7x7x19	7.0	5.7	4.1	10.0	8.6	6.1
7/8	7x7x19	9.3	7.6	5.4	14.0	11.0	8.1
1	7x7x19	12.0	9.7	6.9	18.0	14.0	10.0
1 1/8	7x7x19	14.0	12.0	8.2	21.0	17.0	12.0
1 1/4	7x7x19	17.0	14.0	9.9	26.0	21.0	15.0
3/4	7x6x19 IWRC	6.6	5.4	3.8	9.9	8.0	5.7
7/8	7x6x19 IWRC	8.7	7.1	5.0	13.0	11.0	7.5
1	7x6x19 IWRC	11.0	9.0	6.4	17.0	13.0	9.6
1 1/8	7x6x19 IWRC	13.0	11.0	7.7	20.0	16.0	11.0
1 1/4	7x6x19 IWRC	16.0	13.0	9.2	24.0	20.0	14.0
1 5/16	7x6x19 IWRC	17.0	14.0	10.0	26.0	21.0	15.0
1 3/8	7x6x19 IWRC	19.0	15.0	11.0	28.0	23.0	16.0
1 1/2	7x6x19 IWRC	22.0	18.0	13.0	33.0	27.0	19.0

TABLE H-10
RATED CAPACITIES FOR 2-LEG AND 3-LEG BRIDLE SLINGS
8-Part and 6-Part Braided Rope
6x7 and 6x19 Construction Improved Plow Steel Grade Rope
7x7 Construction Galvanized Aircraft Grade Rope



Rope		Rated Capacities, tons (2,000 pounds)											
Diameter (inches)	Construction	2-leg Bridle Slings						3-leg Bridle Slings					
		30° ¹ (60°) ²		45° Angle		60° ¹ (30°) ²		30° ¹ (60°) ²		45° Angle		60° ¹ (30°) ²	
		8 - Part	6 - Part	8 - Part	6 - Part	8 - Part	6 - Part	8 - Part	6 - Part	8 - Part	6 - Part	8 - Part	6 - Part
3/32	6x7	0.74	0.55	0.60	0.45	0.42	0.32	1.1	0.83	0.90	0.68	0.64	0.48
1/8	6x7	1.3	0.98	1.1	0.80	0.76	0.57	2.0	1.5	1.6	1.2	1.1	0.85
3/16	6x7	2.9	2.2	2.4	1.8	1.7	1.3	4.4	3.3	3.6	2.7	2.5	1.9
3/32	7x7	0.89	0.67	0.72	0.55	0.51	0.39	1.3	1.0	1.1	0.82	0.77	0.58
1/8	7x7	1.6	1.2	1.3	1.0	0.95	0.71	2.5	1.8	2.0	1.5	1.4	1.1
3/16	7x7	3.6	2.7	2.9	2.2	2.1	1.5	5.4	4.0	4.4	3.3	3.1	2.3
3/16	6x19	3.0	2.2	2.4	1.8	1.7	1.3	4.5	3.4	3.7	2.8	2.6	1.9
1/4	6x19	5.3	4.0	4.3	3.2	3.1	2.3	8.0	6.0	6.5	4.9	4.6	3.4
5/16	6x19	8.3	6.2	6.7	5.0	4.8	3.6	12.0	9.3	10.0	7.6	7.1	5.4
3/8	6x19	12.0	8.9	9.7	7.2	6.8	5.1	18.0	13.0	14.0	11.0	10.0	7.7
7/16	6x19	16.0	12.0	13.0	9.8	9.3	6.9	24.0	18.0	20.0	15.0	14.0	10.0
1/2	6x19	21.0	15.0	17.0	13.0	12.0	9.0	31.0	23.0	25.0	19.0	18.0	13.0
9/16	6x19	26.0	20.0	21.0	16.0	15.0	11.0	39.0	29.0	32.0	24.0	23.0	17.0
5/8	6x19	32.0	24.0	26.0	20.0	19.0	14.0	48.0	36.0	40.0	30.0	28.0	21.0
3/4	6x19	46.0	35.0	38.0	28.0	27.0	20.0	69.0	52.0	56.0	42.0	40.0	30.0
7/8	6x19	62.0	47.0	51.0	38.0	36.0	27.0	94.0	70.0	76.0	57.0	54.0	40.0
1	6x19	81.0	61.0	66.0	50.0	47.0	35.0	122.0	91.0	99.0	74.0	70.0	53.0

TABLE H-11
RATED CAPACITIES FOR STRAND LAID GROMMET---HAND TUCKED
Improved Plow Steel Grade Rope

Rope Body		Rated Capacities, tons (2,000 pounds)		
Diameter (inches)	Construction	 Vertical	 Choker	 Vertical Basket ¹
1/4	7x19	0.85	0.64	1.7
5/16	7x19	1.3	1.0	2.6
3/8	7x19	1.9	1.4	3.8
7/16	7x19	2.6	1.9	5.2
1/2	7x19	3.3	2.5	6.7
9/16	7x19	4.2	3.1	8.4
5/8	7x19	5.2	3.9	10.0
3/4	7x19	7.4	5.6	15.0
7/8	7x19	10.0	7.5	20.0
1	7x19	13.0	9.7	26.0
1 1/8	7x19	16.0	12.0	32.0
1 1/4	7x37	18.0	14.0	37.0
1 3/8	7x37	22.0	16.0	44.0
1 1/2	7x37	26.0	19.0	52.0



¹ These values only apply when the D/d ratio is 5 or greater where:
D=Diameter of curvature around which rope is bent.
D=Diameter of rope body.

TABLE H-12
RATED CAPACITIES FOR CABLE LAID GROMMET---HAND TUCKED
7x6x7 and 7x6x19 Construction Improved Plow Steel Grade Rope
7x7x7 Construction Galvanized Aircraft Grade Rope

Cable Body		Rated Capacities, tons (2,000 pounds)		
Diameter (inches)	Construction	 Vertical	 Choker	 Vertical Basket ¹
3/8	7x6x7	1.3	0.95	2.5
9/16	7x6x7	2.8	2.1	5.6
5/8	7x6x7	3.8	2.8	7.6
3/8	7x7x7	1.6	1.2	3.2
9/16	7x7x7	3.5	2.6	6.9
5/8	7x7x7	4.5	3.4	9.0
5/8	7x6x19	3.9	3.0	7.9
3/4	7x6x19	5.1	3.8	10.0
15/16	7x6x19	7.9	5.9	16.0
1 1/8	7x6x19	11.0	8.4	22.0
1 5/16	7x6x19	15.0	11.0	30.0
1 1/2	7x9x19	19.0	14.0	39.0
1 11/16	7x6x19	24.0	18.0	49.0
1 7/8	7x6x19	30.0	22.0	60.0
2 1/4	7x6x19	42.0	31.0	84.0
2 5/8	7x6x19	56.0	42.0	112.0



¹ These values only apply when the D/d ratio is 5 or greater where:
D=Diameter of curvature around which rope is bent.
D=Diameter of rope body.

TABLE H-13
RATED CAPACITIES FOR STRAND LAID ENDLESS SLINGS-MECHANICAL JOINT
Improved Plow Steel Grade Rope

Rope Body		Rated Capacities, tons (2,000 pounds)		
Diameter (inches)	Construction	 Vertical	 Choker	 Vertical Basket ¹
1/4	6x19 IWRC	0.92	0.69	1.8
3/8	6x19 IWRC	2.0	1.5	4.1
1/2	6x19 IWRC	3.6	2.7	7.2
5/8	6x19 IWRC	5.6	4.2	11.0
3/4	6x19 IWRC	8.0	6.0	16.0
7/8	6x19 IWRC	11.0	8.1	21.0
1	6x19 IWRC	14.0	10.0	28.0
1 1/8	6x19 IWRC	18.0	13.0	35.0
1 1/4	6x37 IWRC	21.0	15.0	41.0
1 3/8	6x37 IWRC	25.0	19.0	50.0
1 1/2	6x37 IWRC	29.0	22.0	59.0

¹ These values only apply when the D/d ratio is 5 or greater where:
D=Diameter of curvature around which rope is bent.
D=Diameter of rope body.

TABLE H-14
RATED CAPACITIES FOR CABLE LAID ENDLESS SLINGS-MECHANICAL JOINT
7x7x7 and 7x7x19 Construction Galvanized Aircraft Grade Rope
7x6x19 IWRC Construction Improved Plow Steel Grade Rope

Cable Body		Rated Capacities, tons (2,000 pounds)		
Diameter (inches)	Construction	 Vertical	 Choker	 Vertical Basket ¹
1/4	7x7x7	0.83	0.62	1.6
3/8	7x7x7	1.8	1.3	3.5
1/2	7x7x7	3.0	2.3	6.1
5/8	7x7x7	4.5	3.4	9.1
3/4	7x7x7	6.3	4.7	12.0
5/8	7x7x19	4.7	3.5	9.5
3/4	7x7x19	6.7	5.0	13.0
7/8	7x7x19	8.9	6.6	18.0
1	7x7x19	11.0	8.5	22.0
1 1/8	7x7x19	14.0	10.0	28.0
1 1/4	7x7x19	17.0	12.0	33.0
3/4	7x7x19 IWRC	6.2	4.7	12.0
7/8	7x7x19 IWRC	8.3	6.2	16.0
1	7x7x19 IWRC	10.0	7.9	21.0
1 1/8	7x7x19 IWRC	13.0	9.7	26.0
1 1/4	7x7x19 IWRC	16.0	12.0	31.0
1 3/8	7x7x19 IWRC	18.0	14.0	37.0
1 1/2	7x7x19 IWRC	22.0	16.0	43.0

¹ These values only apply when the D/d ratio is 5 or greater where:
D=Diameter of curvature around which rope is bent.
D=Diameter of rope body.

METAL MESH SLINGS

R 408.14941. Metal mesh slings; marking; rated capacity; coatings.

Rule 4941. (1) Each metal mesh sling shall have permanently affixed to it a durable marking that states the rating capacity for vertical basket hitch and choker hitch loadings.

(2) A handle shall have a rated capacity at least equal to the metal fabric and exhibit no deformation after proof testing.

(3) Coatings which diminish the rated capacity of a sling shall not be applied.

R 408.14942. Metal mesh slings; attachment of handle.

Rule 4942. The fabric and handles shall be joined so that:

- (a) The rated capacity of the sling is not reduced.
- (b) The load is evenly distributed across the width of the fabric.
- (c) Sharp edges will not damage the fabric.

R 408.14943. Metal mesh slings; testing.

Rule 4943. All new and repaired metal mesh slings, including handles, shall not be used unless proof tested by the manufacturer at a minimum of 1 1/2 times their rated capacity. Elastomer impregnated slings shall be proof tested before coating.

R 408.14944. Metal mesh slings; use, temperature limits.

Rule 4944. (1) A metal mesh sling shall not be used to lift loads in excess of their rated capacities as prescribed in Table 15.

(2) A sling not included in this table shall be used only in accordance with the manufacturer's recommendations.

(3) A metal mesh sling which is not impregnated with elastomers may be used in a temperature range from minus 20 degrees Fahrenheit to plus 550 degrees Fahrenheit without decreasing the working load limit. A metal mesh sling impregnated with polyvinyl chloride or neoprene may be used only in a temperature range from zero degrees to plus 200 degrees Fahrenheit. For operations outside these temperature ranges or for metal mesh slings impregnated with other materials, the sling manufacturer's recommendations shall be followed.

TABLE H-15
Rated Capacities
Carbon Steel & Stainless Steel
Metal Mesh Slings

SLING WIDTH IN INCHES				EFFECT OF ANGLE ON RATED CAPACITIES IN BASKET HITCH		

Heavy Duty-10 Ga 35 Spirals/Ft. of sling width

2	1,500	3,000	2,600	2,100	1,500
3	2,700	5,400	4,700	3,800	2,700
4	4,000	8,000	6,900	5,600	4,000
6	6,000	12,000	10,400	8,400	6,000
8	8,000	16,000	13,800	11,300	8,000
10	10,000	20,000	17,000	14,100	10,000
12	12,000	24,000	20,700	16,900	12,000
14	14,000	28,000	24,200	19,700	14,000
16	16,000	32,000	27,700	22,600	16,000
18	18,000	36,000	31,100	25,400	18,000
20	20,000	40,000	34,600	28,200	20,000

Medium Duty-12 Ga 43 Spirals/Ft. of sling width

2	1,350	2,700	2,300	1,900	1,400
3	2,000	4,000	3,500	2,800	2,000
4	2,700	5,400	4,700	3,800	2,700
6	4,500	9,000	7,800	6,400	4,500
8	6,000	12,000	10,400	8,500	6,000
10	7,500	15,000	13,000	10,600	7,500
12	9,000	18,000	15,600	12,700	9,000
14	10,500	21,000	18,200	14,800	10,500
16	12,000	24,000	20,800	17,000	12,000
18	13,500	27,000	23,400	19,100	13,500
20	15,000	30,000	26,000	21,200	15,000

Light Duty-14 Ga 59 Spirals/Ft of sling width

2	900	1,800	1,600	1,300	900
3	1,400	2,800	2,400	2,000	1,400
4	2,000	4,000	3,500	2,800	2,000
6	3,000	6,000	5,200	4,200	3,000
8	4,000	8,000	6,900	5,700	4,000
10	5,000	10,000	8,600	7,100	5,000
12	6,000	12,000	10,400	8,500	6,000
14	8,000	14,000	12,100	9,900	7,000
16		16,000	13,900	11,300	8,000
18	9,000	18,000	15,600	12,700	9,000
20	10,000	20,000	17,300	14,100	10,000

R 408.14945. Metal mesh slings; removal from service; repairs; records.

Rule 4945. (1) A metal mesh sling shall be immediately removed from service if any of the following conditions are present:

- (a) A broken weld or broken brazed joint along the sling edge.
- (b) Reduction in wire diameter of 25% due to abrasion or 15% due to corrosion.
- (c) Lack of flexibility due to distortion of the fabric.
- (d) Distortion of the female handle so that the depth of the slot is increased more than 10%.
- (e) Distortion of either handle so that the width of the eye is decreased more than 10%.
- (f) A 15% reduction of the original cross sectional area of metal of any point around the handle eye.
- (g) Distortion of either handle out of its plane.

(2) A metal mesh sling which is repaired shall not be used unless repaired by a metal mesh sling manufacturer.

(3) Once repaired, each sling shall be permanently marked or tagged, or a written record maintained, to indicate the date and nature of the repairs and the person or organization that performed the repairs. Records of repairs shall be made available for examination.

FIBER ROPE SLINGS**R 408.14951. Natural and synthetic fiber rope slings; rated capacity; diameter of curvature; temperature limits.**

Rule 4951. (1) A fiber rope sling made from conventional 3 strand construction fiber rope shall not be used with a load in excess of the rated capacities prescribed in Tables 16 to 19.

(2) A fiber rope sling shall have a diameter of curvature meeting not less than the minimums prescribed in Figures 4 and 5.

(3) A sling not included in these tables shall be used only in accordance with the manufacturer's recommendations.

(4) A natural or synthetic fiber rope sling, except for a wet frozen sling, may be used in a temperature range from minus 20 degrees Fahrenheit to plus 180 degrees Fahrenheit without decreasing the working load limit. For operations outside this temperature range and for wet frozen slings, the sling manufacturer's recommendations shall be followed.

R 408.14952. Natural and synthetic fiber rope slings; splicing.

Rule 4952. A spliced fiber rope sling shall not be used unless it has been spliced in accordance with the following minimum requirements and in accordance with any additional recommendations of the manufacturer:

- (a) In manila rope, an eye splice shall consist of at least 3 full tucks, and short splices shall consist of at least 6 full tucks, 3 on each side of the splice center line.
- (b) In synthetic fiber rope, an eye splice shall consist of at least 4 full tucks, and short splices shall consist of at least 8 full tucks, 4 on each side of the center line.
- (c) A strand end tail shall not be trimmed flush with the surface of the rope immediately adjacent to the full tucks. This applies to all types of fiber rope and both eye and short splices. For fiber rope under 1 inch in diameter, the tail shall project at least 6 rope diameters beyond the last full tuck. For fiber rope 1 inch in diameter and larger, the tail shall project at least 6 inches beyond the last full tuck. Where a projecting tail interferes with the use of the sling, the tail shall be tapered and spliced into the body of the rope, using at least 2 additional tucks, which will require a tail length of approximately 6 rope diameters beyond the last full tuck.
- (d) A fiber rope sling shall have a minimum clear length of rope between the eye splices equal to 10 times the rope diameter.
- (e) A knot shall not be used in lieu of a splice.
- (f) A clamp not designed specifically for fiber ropes shall not be used for splicing.
- (g) For any eye splice, the eye shall be of a size to provide an included angle of not greater than 60° at the splice when the eye is placed over the load or support.

R 408.14953. Natural and synthetic fiber rope slings; end attachments.

Rule 4953. A fiber rope sling shall not be used if an end attachment in contact with the rope has a sharp edge or projection.

R 408.14954. Natural and synthetic fiber rope slings; removal from service; prohibition.

Rule 4954. (1) A natural and synthetic fiber rope sling shall be immediately removed from service if any of the following conditions are present:

- (a) Abnormal wear.
- (b) Powdered fiber between strands.
- (c) Broken or cut fibers.
- (d) Variations in the size or roundness of strands.
- (e) Discoloration or rotting.
- (f) Distortion of hardware in the sling.

(2) Only a fiber rope sling made from new rope shall be used. Use of a repaired or reconditioned fiber rope sling is prohibited.

SYNTHETIC WEB SLINGS

R 408.14961. Synthetic web slings; marking or coding rated capacities.

Rule 4961. Each sling shall be marked or coded to show the rated capacities for each type of hitch and type of synthetic web material.

R 408.14962. Synthetic web slings; webbing size and edges.

Rule 4962. Synthetic webbing shall be of uniform thickness and width, and selvage edges shall not be split from the webbing's width.

R 408.14963. Synthetic web slings; fittings.

Rule 4963. (1) Fittings shall be:

- (a) Of a minimum breaking strength equal to that of the sling.
- (b) Free of all sharp edges that could in any way damage the webbing.

(2) Stitching shall be the only method used to attach end fittings to webbing and to form eyes. The thread shall be in an even pattern and contain a sufficient number of stitches to develop the full breaking strength of the sling.

R 408.14964. Synthetic web slings; rated capacity; use; temperature limits.

Rule 4964. (1) A synthetic web sling illustrated in Figure 6 shall not be used with loads in excess of the rated capacities specified in Tables 20 to 22. A sling not included in these tables shall be used only in accordance with the manufacturer's recommendations.

(2) When a synthetic web sling is used, the following precautions shall be taken:

- (a) A nylon web sling shall not be used where fumes, vapors, sprays, mists, or liquids of acids or phenolics are present.
- (b) A polyester and polypropylene web sling shall not be used where fumes, vapors, sprays, mists, or liquids of caustics are present.
- (c) A web sling with aluminum fittings shall not be used where fumes, vapors, sprays, mists, or liquids of caustics are present.

(3) A synthetic web sling of polyester and nylon shall not be used at a temperature in excess of 180 degrees Fahrenheit. A polypropylene web sling shall not be used at a temperature in excess of 200 degrees Fahrenheit.

R 408.14965. Synthetic web slings; removal from service; repairs; certificate of proof test; prohibition.

Rule 4965. (1) A synthetic web sling shall be immediately removed from service if any of the following conditions are present:





- (a) Acid or caustic burns.
- (b) Melting or charring of any part of the sling surface.
- (c) Snags, punctures, tears, or cuts.
- (d) Broken or worn stitches.
- (e) Distortion of fittings.

(2) A synthetic web sling shall be repaired only by a sling manufacturer.

(3) Each repaired sling shall be proof tested by the manufacturer to twice the rated capacity prior to its return to service. The employer shall retain a certificate of the proof test and make it available for examination.





(4) A sling, including webbing and fittings, which has been repaired in a temporary manner shall not be used.

**TABLE 16
MANILA ROPE SLINGS**

Rope Diameter Nominal in Inches	Nominal Weight per 100 Feet in Pounds	Capacity is in Pounds											
		Eye and Eye Sling						Endless Sling					
		 Vertical Hitch	 Choker Hitch	Basket Hitch; Angle of Rope to Horizontal				 Vertical Hitch	 Choker Hitch	Basket Hitch; Angle of Rope to Horizontal			
				90°(0°)	60°(30°)	45°(45°)	30°(60°)			90°(0°)	60°(30°)	45°(45°)	30°(60°)
1/2	7.5	480	240	960	830	680	480	865	430	1,730	1,500	1,220	865
9/16	10.4	620	310	1,240	1,070	875	620	1,120	560	2,230	1,930	1,580	1,120
5/8	13.3	790	395	1,580	1,370	1,120	790	1,420	710	2,840	2,460	2,010	1,420
3/4	16.7	970	485	1,940	1,680	1,370	970	1,750	875	3,490	3,020	2,470	1,750
13/16	19.5	1,170	585	2,340	2,030	1,650	1,170	2,110	1,050	4,210	3,650	2,980	2,110
7/8	22.5	1,390	695	2,780	2,410	1,970	1,390	2,500	1,250	5,000	4,330	3,540	2,500
1	27.0	1,620	810	3,240	2,810	2,290	1,620	2,920	1,460	5,830	5,050	4,120	2,920
1 1/16	31.3	1,890	945	3,780	3,270	2,670	1,890	3,400	1,700	6,800	5,890	4,810	3,400
1 1/8	36.0	2,160	1,080	4,320	3,740	3,050	2,160	3,890	1,940	7,780	6,730	5,500	3,890
1 1/4	41.7	2,430	1,220	4,860	4,210	3,440	2,430	4,370	2,190	8,750	7,580	6,190	4,370
1 5/16	47.9	2,700	1,350	5,400	4,680	3,820	2,700	4,860	2,430	9,720	8,420	6,870	4,860
1 1/2	59.9	3,330	1,670	6,660	5,770	4,710	3,330	5,990	3,000	12,000	10,400	8,480	5,990
1 5/8	74.6	4,050	2,030	8,100	7,010	5,730	4,050	7,290	2,650	14,600	12,600	10,300	7,290
1 3/4	89.3	4,770	2,390	9,540	8,260	6,740	4,770	8,590	4,290	17,200	14,900	12,100	8,590
2	107.5	5,580	2,790	11,200	9,660	7,890	5,580	10,000	5,020	20,100	17,400	14,200	10,000
2 1/3	125.0	6,480	3,240	13,000	11,200	9,160	6,480	11,700	5,830	23,300	20,200	16,500	11,700
2 1/4	146.0	7,380	3,690	14,800	12,800	10,400	7,380	13,300	6,640	26,600	23,000	18,800	13,300
2 1/2	166.7	8,370	4,190	16,700	14,500	11,800	8,370	15,100	7,530	30,100	26,100	21,300	15,100
2 5/8	190.8	9,360	4,680	18,700	16,200	13,200	9,360	16,800	8,420	33,700	29,200	23,800	16,800





See figures 4 and 5 for sling configuration descriptions.

**TABLE 17
NYLON ROPE SLINGS**

Rope Diameter Nominal in Inches	Nominal Weight per 100 Feet in Pounds	Capacity is in Pounds											
		Eye and Eye Sling						Endless Sling					
		 Vertical Hitch	 Choker Hitch	Basket Hitch; Angle of Rope to Horizontal				 Vertical Hitch	 Choker Hitch	Basket Hitch; Angle of Rope to Horizontal			
				90°(0°)	60°(30°)	45°(45°)	30°(60°)			90°(0°)	60°(30°)	45°(45°)	30°(60°)
1/2	6.5	635	320	1,270	1,100	900	635	1,140	570	2,290	1,980	1,620	1,140
9/16	8.3	790	395	1,580	1,370	1,120	790	1,420	710	2,840	2,460	2,010	1,420
5/8	10.5	1,030	515	2,060	1,780	1,460	1,030	1,850	925	3,710	3,210	2,620	1,850
3/4	14.5	1,410	705	2,820	2,440	1,990	1,410	2,540	1,270	5,080	4,400	3,590	2,540
13/16	17.0	1,680	840	3,360	2,910	2,380	1,680	3,020	1,510	6,050	5,240	4,280	3,020
7/8	20.0	1,980	990	3,960	3,430	2,800	1,980	3,560	1,780	7,130	6,170	5,040	3,560
1	26.0	2,480	1,240	4,960	4,300	3,510	2,480	4,460	2,230	8,930	7,730	6,310	4,460
1 1/16	29.0	2,850	1,430	5,700	4,940	4,030	2,850	5,130	2,570	10,300	8,890	7,260	5,130
1 1/8	34.0	3,270	1,640	6,540	5,660	4,620	3,270	5,890	2,940	11,800	10,200	8,330	5,890
1 1/4	40.0	3,710	1,860	7,420	6,430	5,250	3,710	6,680	3,340	13,400	11,600	9,450	6,680
1 5/16	45.0	4,260	2,130	8,520	7,380	6,020	4,260	7,670	3,830	15,300	13,300	10,800	6,770
1 1/2	55.0	5,250	2,630	10,500	9,090	7,420	5,250	9,450	4,730	18,900	16,400	13,400	9,450
1 5/8	68.0	6,440	3,220	12,900	11,200	9,110	6,440	11,600	5,800	23,200	20,100	16,400	11,600
1 3/4	83.0	7,720	3,860	15,400	13,400	10,900	7,720	13,900	6,950	27,800	24,100	19,700	13,900
2	95.0	9,110	4,560	18,200	15,800	12,900	9,110	16,400	8,200	32,800	28,400	23,200	16,400
2 1/8	109.0	10,500	5,250	21,000	18,200	14,800	10,500	18,900	9,450	37,800	32,700	26,700	18,900
2 1/4	129.0	12,400	6,200	24,800	21,500	17,500	12,400	22,300	11,200	44,600	38,700	31,600	22,300
2 1/2	149.0	13,900	6,950	27,800	24,100	19,700	13,900	25,000	12,500	50,000	43,300	35,400	25,000
2 5/8	168.0	16,000	8,000	32,000	27,700	22,600	16,000	28,800	14,400	57,600	49,900	40,700	28,800





See figures 4 and 5 for sling configuration descriptions.

**TABLE 18
POLYESTER ROPE SLINGS**

Rope Diameter Nominal in Inches	Nominal Weight per 100 Feet in Pounds	Capacity is in Pounds											
		Eye and Eye Sling						Endless Sling					
		 Vertical Hitch	 Choker Hitch	Basket Hitch; Angle of Rope to Horizontal				 Vertical Hitch	 Choker Hitch	Basket Hitch; Angle of Rope to Horizontal			
				90°(0°)	60°(30°)	45°(45°)	30°(60°)			90°(0°)	60°(30°)	45°(45°)	30°(60°)
1/2	8.0	635	320	1,270	1,100	900	635	1,140	570	2,290	1,980	1,620	1,140
9/16	10.2	790	395	1,580	1,370	1,120	790	1,420	710	2,840	2,460	2,010	1,420
5/8	13.0	990	495	1,980	1,710	1,400	990	1,780	890	3,570	3,090	2,520	1,780
3/4	17.5	1,240	620	2,480	2,150	1,750	1,240	2,230	1,120	4,470	3,870	3,160	2,230
13/16	21.0	1,540	770	3,080	2,670	2,180	1,540	2,770	1,390	5,540	4,800	3,920	2,770
7/8	25.0	1,780	890	3,560	3,080	2,520	1,780	3,200	1,600	6,410	5,550	4,530	3,200
1	30.5	2,180	1,090	4,360	3,780	3,080	2,180	3,920	1,960	7,850	6,800	5,550	3,920
1 1/16	34.5	2,530	1,270	5,060	4,380	3,580	2,530	4,550	2,280	9,110	7,990	6,440	4,550
1 1/8	40.0	2,920	1,460	5,840	5,060	4,130	2,920	5,260	2,630	10,500	9,100	7,440	5,260
1 1/4	46.3	3,290	1,650	6,580	5,700	4,650	3,290	5,920	2,960	11,800	10,300	8,380	5,920
1 5/16	52.5	3,710	1,860	7,420	6,430	5,250	3,710	6,680	3,340	13,400	11,600	9,450	6,680
1 1/2	66.8	4,630	2,320	9,260	8,020	6,550	4,630	8,330	4,170	16,700	14,400	11,800	8,330
1 5/8	82.0	5,640	2,820	11,300	9,770	7,980	5,640	10,200	5,080	20,300	17,600	14,400	10,200
1 3/4	98.0	6,710	3,360	13,400	11,600	9,490	6,710	12,100	6,040	24,200	20,900	17,100	12,100
2	118.0	7,920	3,960	15,800	13,700	11,200	7,920	14,300	7,130	28,500	24,700	20,200	14,300
2 1/8	135.0	9,110	4,460	18,200	15,800	12,900	9,110	16,400	8,200	32,800	28,400	23,200	16,400
2 1/4	157.0	10,600	5,300	21,200	18,400	15,000	10,600	19,100	9,540	38,200	33,100	27,000	19,100
2 1/2	181.0	12,100	6,050	24,200	21,000	17,100	12,100	21,800	10,900	43,600	37,700	30,800	21,800
2 5/8	205.0	13,600	6,800	27,200	23,600	19,200	13,600	24,500	12,200	49,000	42,400	34,600	24,500

See figures 4 and 5 for sling configuration descriptions.

**TABLE 19
POLYPROPYLENE ROPE SLINGS**

Rope Diameter Nominal in Inches	Nominal Weight per 100 Feet in Pounds	Capacity is in Pounds											
		Eye and Eye Sling						Endless Sling					
		 Vertical Hitch	 Choker Hitch	Basket Hitch; Angle of Rope to Horizontal				 Vertical Hitch	 Choker Hitch	Basket Hitch; Angle of Rope to Horizontal			
				90°(0°)	60°(30°)	45°(45°)	30°(60°)			90°(0°)	60°(30°)	45°(45°)	30°(60°)
1/2	4.7	645	325	1,290	1,120	910	645	1,160	580	2,320	2,010	1,640	1,160
9/16	6.1	780	390	1,560	1,350	1,100	780	1,400	700	2,810	2,430	1,990	1,400
5/8	7.5	950	475	1,900	1,650	1,340	950	1,710	855	3,420	2,960	2,420	1,710
3/4	10.7	1,300	650	2,600	2,250	1,840	1,300	2,340	1,170	4,680	4,050	3,310	2,340
13/16	12.7	1,520	760	3,040	2,630	2,150	1,520	2,740	1,370	5,470	4,740	3,870	2,740
7/8	15.0	1,760	880	3,520	3,050	2,490	1,760	3,170	1,580	6,340	5,490	4,480	3,170
1	18.0	2,140	1,070	4,280	3,700	3,030	2,140	3,850	1,930	7,700	6,670	5,450	3,860
1-1/16	20.4	2,450	1,230	4,900	4,240	3,460	2,450	4,410	2,210	8,820	7,640	6,240	4,410
1-1/8	23.7	2,800	1,400	5,600	4,850	3,960	2,800	5,040	2,520	10,100	8,730	7,130	5,040
1-1/4	27.0	3,210	1,610	6,420	5,560	4,540	3,210	5,780	2,890	11,600	10,000	8,170	5,780
1-5/16	30.5	3,600	1,800	7,200	6,240	5,090	3,600	6,480	3,240	13,000	11,200	9,170	6,480
1-1/2	38.5	4,540	2,270	9,080	7,860	6,420	4,540	8,170	4,090	16,300	14,200	11,600	8,170
1-5/8	47.5	5,510	2,760	11,000	9,540	7,790	5,510	9,920	4,960	19,800	17,200	14,000	9,920
1-3/4	57.0	6,580	3,290	13,200	11,400	9,300	6,580	11,800	5,920	23,700	20,500	16,800	11,800
2	69.0	7,960	3,980	15,900	13,800	11,300	7,960	14,300	7,160	28,700	24,800	20,300	14,300
2-1/8	80.0	9,330	4,670	18,700	16,200	13,200	9,330	16,800	8,400	33,600	29,100	23,800	16,800
2-1/4	92.0	10,600	5,300	21,200	18,400	15,000	10,600	19,100	9,540	38,200	33,100	27,000	19,100
2-1/2	107.0	12,200	6,100	24,400	21,100	17,300	12,200	22,000	11,000	43,900	38,000	31,100	22,000
2-5/8	120.0	13,800	6,900	27,600	23,900	19,600	13,800	24,800	12,400	49,700	43,000	35,100	24,800

See figures 4 and 5 for sling configuration descriptions.

TABLE 20

Rated Capacity in Pounds, Synthetic Web Slings, 1,000 lbs. Per Inch of Width, Single Ply

Sling Body Width, Inches	Triangle – Choker Slings, Type I Triangle – Triangle Slings, Type II Eye & Eye with Flat Eye Slings, Type III Eye & Eye with Twisted Eye Slings, Type IV						Endless Slings, Type V						Return Eye Slings, Type VI					
	Vert.	Choker	Vert. Basket	30 Basket	45 Basket	60 Basket	Vert.	Choker	Vert. Basket	30 Basket	45 Basket	60 Basket	Vert.	Choker	Vert. Basket	30 Basket	45 Basket	60 Basket
1	1,000	750	2,000	1,700	1,400	1,000	1,600	1,300	3,200	2,800	2,300	1,600	800	650	1,600	1,400	1,150	800
2	2,000	1,500	4,000	3,500	2,800	2,000	3,200	2,600	6,400	5,500	4,500	3,200	1,600	1,300	3,200	2,800	2,300	1,600
3	3,000	2,200	6,000	5,200	4,200	3,000	4,800	3,800	9,600	8,300	6,800	4,800	2,400	1,950	4,800	4,150	3,400	2,400
4	4,000	3,000	8,000	6,900	5,700	4,000	6,400	5,100	12,800	11,100	9,000	6,400	3,200	2,600	6,400	5,500	4,500	3,200
5	5,000	3,700	10,000	8,700	7,100	5,000	8,000	6,400	16,000	13,900	11,300	8,000	4,000	3,250	8,000	6,900	5,650	4,000
6	6,000	4,500	12,000	10,400	8,500	6,000	9,600	7,700	19,200	16,600	13,600	9,600	4,800	3,800	9,600	8,300	6,800	4,800

- Notes: 1. All angles shown are measured from the vertical.
2. Capacities for intermediate widths not shown may be obtained by interpolation.

TABLE 21

Rated Capacity in Pounds, Synthetic Web Slings, 1,200 Lbs. Per Inch of Width, Single Ply

Sling Body Width, Inches	Triangle – Choker Slings, Type I Triangle – Triangle Slings, Type II Eye & Eye with Flat Eye Slings, Type III Eye & Eye with Twisted Eye Slings, Type IV						Endless Slings, Type V						Return Eye Slings, Type VI					
	Vert.	Choker	Vert. Basket	30 Basket	45 Basket	60 Basket	Vert.	Choker	Vert. Basket	30 Basket	45 Basket	60 Basket	Vert.	Choker	Vert. Basket	30 Basket	45 Basket	60 Basket
1	1,200	900	2,400	2,100	1,700	1,200	1,900	1,500	3,800	3,300	2,700	1,900	950	750	1,900	1,650	1,350	950
2	2,400	1,800	4,800	4,200	3,400	2,400	3,800	3,000	7,600	6,600	5,400	3,800	1,900	1,500	3,800	3,300	2,700	1,900
3	3,600	2,700	7,200	6,200	5,100	3,600	5,800	4,600	11,600	10,000	8,200	5,800	2,850	2,250	5,700	4,950	4,050	2,850
4	4,800	3,600	9,600	8,300	6,800	4,800	7,700	6,200	15,400	13,300	10,900	7,700	3,800	3,000	7,600	6,600	5,400	3,800
5	6,000	4,500	12,000	10,400	8,500	6,000	9,600	7,700	19,200	16,600	13,600	9,600	4,750	3,750	9,500	8,250	6,750	4,750
6	7,200	5,400	14,400	12,500	10,200	7,200	11,500	9,200	23,000	19,900	16,300	11,500	5,800	4,600	11,600	10,000	8,200	5,800

- Notes: 1. All angles shown are measured from the vertical.
2. Capacities for intermediate widths not shown may be obtained by interpolation.

TABLE 22

Rated Capacity in Pounds, Synthetic Web Slings, 1,600 Lbs. Per Inch of Width, Single Ply

Sling Body Width, Inches	Triangle – Choker Slings, Type I Triangle – Triangle Slings, Type II Eye & Eye with Flat Eye Slings, Type III Eye & Eye with Twisted Eye Slings, Type IV						Endless Slings, Type V						Return Eye Slings, Type VI					
	Vert.	Choker	Vert. Basket	30 Basket	45 Basket	60 Basket	Vert.	Choker	Vert. Basket	30 Basket	45 Basket	60 Basket	Vert.	Choker	Vert. Basket	30 Basket	45 Basket	60 Basket
1	1,600	1,200	3,200	2,800	2,300	1,600	2,600	2,100	5,200	4,500	3,700	2,600	1,050	1,050	2,600	2,250	1,850	1,300
2	3,200	2,400	6,400	5,500	4,500	3,200	9,100	4,100	10,200	8,800	7,200	5,100	2,600	2,100	5,200	4,500	3,700	2,600
3	4,800	3,600	9,600	8,300	6,800	4,800	7,700	6,200	15,400	13,300	10,900	7,700	3,900	3,150	7,800	6,750	5,500	3,900
4	6,400	4,800	12,800	11,100	9,000	6,400	10,200	8,200	20,400	17,700	14,400	10,200	5,100	4,100	10,200	8,800	7,200	5,100
5	8,000	6,000	16,000	13,800	11,300	8,000	12,800	10,200	25,600	22,200	18,100	12,800	6,400	5,150	12,800	11,050	9,050	6,400
6	9,600	7,200	19,200	16,600	13,600	9,600	15,400	12,300	30,800	26,700	21,800	15,400	7,700	6,200	15,400	13,300	10,900	7,700

- Notes: 1. All angles shown are measured from the vertical.
2. Capacities for intermediate widths not shown may be obtained by interpolation.



Michigan Occupational Safety and Health Administration
PO Box 30643
Lansing, Michigan 48909-8143
Ph: 517.322.1845

The Department of Licensing and Regulatory Affairs will not discriminate against any individual or group because of race, sex, religion, age, national origin, color, marital status, disability, or political beliefs. Auxiliary aids, services and other reasonable accommodations are available upon request to individuals with disabilities.