



DEPARTMENT OF LABOR & ECONOMIC GROWTH
DIRECTOR'S OFFICE
GENERAL INDUSTRY SAFETY STANDARDS

Filed with the Secretary of State on December 13, 1974 (as amended October 28, 1976)
(as amended May 17, 1983) (as amended January 11, 1988) **(as amended June 4, 2008)**

These rules become effective 14 days after filing with the Secretary of State

(By authority conferred on the director of the department of labor and economic growth by sections 16 and 21 of 1974 PA 154, and Executive Reorganization Order Nos. 1996-2 and 2003-1, MCL 408.1016, 408.1021, 445.2001, and 445.2011)

R 408.15801, R 408.15803, R 408.15804, R 408.15805, R 408.15811, R 408.15812, R 408.15821, R 408.15825, R 408.15831, R 408.15832, and R 408.15833 of the Michigan Administrative Code are amended, and, R 408.15802, R 408.15810, R 408.15815, R 408.15817, R 408.15836, R 408.15839, and R 408.15842 are added; and R 408.15823, R 408.15824, and R 408.15830 are rescinded as follows:

PART 58. AERIAL WORK PLATFORMS

TABLE OF CONTENTS

GENERAL PROVISIONS	1	R 408.15817. Preoperational procedures; platform	
R 408.15801 Scope.	1	Inspections	3
R 408.15802 Equipment covered	1	CONSTRUCTION, TESTING, AND USE PROVISIONS	3
R 408.15803 Definitions A to I.	2	R 408.15821 Construction, modification, and remounting	4
R 408.15804 Definitions M to Q.	2	R 408.15825 Controls.	4
R 408.15805 Definitions S to Y.	2	R 408.15831 Inspection, maintenance; testing	5
R 408.15810 Adoption of standards by reference; access to		R 408.15832 Electrical hazards.....	5
other MIOSHA rules.....	2	R 408.15833 Vehicles; traffic controls	6
R 408.15811 Employer responsibility.....	3	R 408.15836 Fall protection	7
R 408.15812 Employee responsibility.....	3	R 408.15839 Operating procedures	7
R 408.15815 Training; permits.....	3	R 408.15842 Figures	8

GENERAL PROVISIONS

R 408.15801. Scope.

Rule 5801. (1) These rules apply to the construction, operation, maintenance, and inspection of aerial work platforms with either manual or powered mobility. These rules do not apply to construction operations as defined by 1974 PA 154, MCL 408.1001 to MCL 408.1094. -

(2) Fire fighting equipment and powered industrial trucks are not included in these rules but are provided for in general industry safety standards Part 74, "Fire Fighting," R 408.17401 to R 408.17464, and Part 21. "Powered Industrial Trucks," R 408.12101 to R 408.12193.

R 408.15802 Equipment covered.

Rule 5802. These rules apply to equipment that has a primary function of elevating personnel, together with their tools and necessary materials, on a platform, which is mechanically positioned. The units covered are described by the following American National Standards Institute Standards:

- (a) ANSI standard A92.2 2002 edition, "Vehicle-Mounted Elevating and Rotating Aerial Devices," which is adopted by reference in R 408.15810. This standard applies to vehicle-mounted devices installed on commercial chassis and covers the following type of units (See figure 1):
 - (i) Extensible boom aerial devices
 - (ii) Aerial ladders.

- (iii) Articulating boom aerial devices.
- (iv) Vertical towers.
- (v) A combination of any of the equipment specified in paragraphs (i) to (iv) of this subdivision.
- (b) ANSI standard A92.3 2006 edition, "Manually Propelled Elevating Aerial Platforms", which is adopted by reference in R 408.15810. This standard applies to work platforms which are manually propelled, which are vertically adjustable by manual or powered means, and which may be towed or manually moved horizontally on wheels or casters that are an integral part of the work platform base. (See figure 2).
- (c) ANSI standard A92.5 2006 edition, "Boom-Supported Elevating Work Platforms", which is adopted by reference in R 408.15810. This standard applies to all integral frame, boom-supported elevating work platforms which telescope, articulate, rotate, or extend beyond the base dimensions. (See figure 3).
- (d) ANSI standard A92.6 1999 edition, "Self-Propelled Elevating Work Platforms," which is adopted by reference in R 408.15810. This standard applies to self-propelled vertically adjustable integral chassis work platforms. Such work platforms are power operated with primary controls for all movement operated from the platform. (See figure 4).

R 408.15803 Definitions; A to I.

Rule 5803. (1) "Aerial device" or "aerial work platform" means an entire device that is designed and manufactured to raise personnel to an elevated work position on a platform supported by scissors, masts, or booms; or any vehicle-mounted device, telescoping or articulating or both, which is used to position an employee.

(2) **"Aerial ladder"** means an aerial device consisting of a single- or multiple-section extensible ladder.

(3) **"Articulating boom platform"** means an aerial device with 2 or more hinged boom sections.

(4) **"Authorized person"** means a person who is approved and assigned to perform specific types of duties by the employer and who is qualified to perform those duties because of his or her training or experience.

(5) **"Commercial chassis"** means a vehicle that is built for over-the-road (roadway) travel.

(6) **"Exposed power line"** means a power line that is not isolated or guarded.

(7) **"Extensible boom platform"** means an aerial device, except ladders, with a telescopic or extensible boom. A telescopic derrick with a personnel platform attachment shall be considered to be an extensible boom platform when used with a personnel platform.

(8) **"Insulated aerial device"** means an aerial device designed for work on or near energized lines and apparatus.

R 408.15804. Definitions M to Q.

Rule 5804. (1) "Mechanically positioned" means that the elevating assembly, whether a mechanical (cable or chain), hydraulic, pneumatic, electric or other powered mechanism, is used to raise or lower the platform.

(2) **"Mobile unit"** means a combination of an aerial device, vehicle and related equipment.

(3) **"Override"** means to transfer or to take away platform control functions by another station.

(4) **"Platform"** means the portion of an aerial work platform, such as a bucket, basket, stand, cage, or the equivalent, that is designed to be occupied by personnel.

(5) **"Power line"** means a distribution or transmission electrical line.

(6) **"Qualified line clearance tree trimmer"** means an employee trained to work in proximity of energized power transmission and distribution lines. An employee in a training program is included in this definition.

(7) **"Qualified lineman"** means an employee trained and authorized to work on or near energized lines. An employee in a training program is included in this definition.

(8) **"Qualified person"** means a person who possesses a recognized degree, certificate, professional standing, or skill and who, by knowledge, training, and experience, has demonstrated the ability to deal with problems relating to the subject matter, the work, or the project.

(9) **"Qualified telecommunications employee"** means an employee trained to work on communication lines in the proximity of energized power transmission and distribution lines.

R 408.15805 Definitions; S to Y.

Rule 5805. (1) "Safety factor" means the ratio of the braking strength of a piece of material or object to maximum designed load or stress applied when in use.

(2) **"Vehicle"** means any carrier that is not manually propelled.

(3) **"Vehicle-mounted elevating and rotating work platform"** means an aerial device or aerial work platform.

(4) **"Vertical tower"** means an aerial device designed to elevate a platform in a substantially vertical axis on a level surface.

(5) **"Yield point"** means the point where material begins to take a permanent deformation.

R 408.15810. Adoption of standards by reference; access to other MIOSHA rules.

Rule 5810. (1) The standards specified in this rule, except for the standards specified in subrule (2) of this rule, are adopted by reference.

(a) The following ANSI standards are available from Global Engineering Documents, 15 Inverness Way East, Englewood, Colorado, 80112, USA, telephone number: 1-800-854-7179 or via the internet at website: <http://global.ihc.com>; at a cost, as of the time of adoption of these rules, as stated in this subrule:

(i) American National Standard Institute Standard ANSI A92.2, "Standard for Vehicle-Mounted Elevating and Rotating Work Platforms," 1969 edition. Cost: \$20.00.

(ii) American National Standard Institute Standard ANSI A92.2, "Vehicle-Mounted Elevating and Rotating Aerial Devices," 2002 edition. Cost: \$68.00.

(iii) American National Standard Institute Standard ANSI A92.3, "Manually Propelled Elevating Work Platforms", 1990 edition. Cost: \$68.00.

(iv) American National Standard Institute Standard ANSI A92.3, "Manually Propelled Elevating Aerial Platforms", 2006 edition. Cost: \$68.00.

(v) American National Standard Institute Standard ANSI A92.5, "Boom-Supported Elevating Work Platforms", 1992 edition. Cost: \$68.00.

(vi) American National Standard Institute Standard ANSI A92.5, "Boom-Supported Elevating Work Platforms", 2006 edition. Cost: \$68.00.

(vii) American National Standard Institute Standard ANSI A92.6, "Self-Propelled Elevating Work Platforms," 1999 edition. Cost: \$68.00.

(b) Part 6: Temporary Traffic Control of the Manual on Uniform Traffic Control Devices for Streets and Highways, 2005 Michigan MUTCD/2003 Federal Edition, is adopted by reference in these rules and is available at no cost from the Michigan Department of Transportation via the internet at website: www.michigan.gov/mdot. The entire 2005 MMUTCD may be purchased from Michigan Technological University, Local Technical Assistance Program, Room 309 Dillman Building, 1400 Townsend Drive, Houghton, Michigan, 49931; (906) 487-2102; at a cost of \$135.00 as of the time of publication of these rules.

(c) The standards adopted in subrule 1(a) and (b) of this rule are also available for inspection at the Department of Labor and Economic Growth, MIOSHA Standards Section, 7150 Harris Drive, P.O. Box 30643, Lansing, Michigan, 48909-8143.

(d) Copies of the standards adopted in subrule 1(a) and (b) of this rule may be obtained quickest from the publisher or may also be obtained from the Department of Labor and Economic Growth, MIOSHA Standards Section, 7150 Harris Drive, P.O. Box 30643, Lansing, Michigan, 48909-8143, at the cost charged in subrule 1(a) and (b) of this rule, plus \$20 for shipping and handling.

(2) The following Michigan Occupational Safety and Health Standards are referenced in these rules. Up to 5 copies of these standards may be obtained at no charge from the Michigan Department of Labor and Economic Growth, MIOSHA Standards Section, 7150 Harris Drive, P.O. Box 30643, Lansing, Michigan, 48909-8143 or via the internet at web-site: www.michigan.gov/mioshastandards. For quantities greater than 5, the cost, as of the time of adoption of these rules, is 4 cents per page.

- (a) General Industry Safety Standard Part 7. Guards for Power Transmission, R 408.10701 to R 408.10765.
- (b) General Industry Safety Standard Part 21. Powered Industrial Trucks, R 408.12101 to R 408.12193.
- (c) General Industry Safety Standard Part 33. Personal Protective Equipment, R 408.13301 to R 408.13398.
- (d) General Industry Safety Standard Part 53. Tree Trimming and Removal, R 408.15301 to R 408.15363.
- (e) General Industry Safety Standard Part 74. Fire Fighting, R 408.17401 to R 408.17464.
- (f) Construction Safety Standard Part 22. Signals, Signs, Tags, and Barricades, R 408.42201 to R 408.42243.
- (g) Construction Safety Standard Part 45. Fall Protection, R 408.44501 to R 408.44502.

R 408.15811. Employer responsibility.

Rule 5811. An employer shall do all of the following:

- (a) Provide training to employees in the operations, hazards, safeguards, and safe practices described in these rules by a qualified person.
- (b) Ensure that employees do not engage in the activities to which these rules apply until such employees have received training.
- (c) Maintain an aerial device in a condition free of known defects and hazards, which could cause an injury.

R 408.15812. Employee responsibility.

Rule 5812. An employee shall do both of the following:

- (a) Operate an aerial device only after being trained in the operations, hazards, safeguards, and safe practices required by these rules by a qualified person and authorized by the employer.
- (b) Report known defects and hazards concerning an aerial device to the supervisor.

R 408.15815. Training; permits.

Rule 5815. (1) An employer shall provide each employee who will operate the aerial work platform with instruction and training regarding the equipment before a permit is issued or reissued. Such instruction and training shall include the following:

- (a) Instruction by a qualified person in the intended purpose and function of each of the controls.
- (b) Training by a qualified person or reading and understanding the manufacturer's or owner's operating instructions and safety rules.
- (c) Understanding by reading or by having a qualified person explain, all decals, warnings, and instructions displayed on the aerial work platform.
- (d) Reading and understanding the provisions of this subrule and subrules (1) to (9) of this rule or be trained by a qualified person on their content.

(2) An employer shall provide the operator of an aerial work platform with an aerial work platform permit.

(3) The requirements of subrule (1)(a), (b), (c), and (d) of this rule shall be met before an employee is issued a permit.

(4) A permit shall be carried by the operator or be available at the job site/work place and shall be displayed upon request by a department of labor and economic growth representative.

(5) A permit shall indicate the type of aerial work platforms an operator has been trained on and is qualified to operate.

(6) A permit to operate an aerial work platform is valid only when performing work for the employer who issued the permit. A permit shall be issued for a period of not more than 3 years.

(7) A permit shall contain all of the following information (see sample permit):

- (a) Firm name.
- (b) Operator's name.
- (c) Name of issuing authority. (Authorized by).
- (d) The following types of aerial work platforms the operator is authorized to operate:
 - (i) Vehicle-mounted elevating work platform such as:
 - (1) Extensible boom aerial devices.
 - (2) Aerial ladders.
 - (3) Articulating boom aerial devices.
 - (4) Vertical towers.
 - (ii) Manually propelled elevating work platforms.
 - (iii) Boom-supported elevating work platforms.
 - (iv) Self-propelled elevating work platforms.
- (e) Date issued.
- (f) Expiration date.

(8) A sample permit is set forth as follows:

SAMPLE PERMIT			
AERIAL WORK PLATFORM PERMIT <i>(Firm Name)</i>			
<hr/> (Name)			
Type of aerial work platform authorized to operate:			
Date Issued	Type	Authorized by	Expiration Date
_____	_____	_____	_____
_____	_____	_____	_____

(9) The manufacturer's operating instructions and safety rules shall be provided and maintained in a legible manner on each unit by the employer.

R 408.15817. Preoperational procedures; platform inspections.

Rule 5817. (1) An operator shall inspect an aerial work platform for defects that would affect its safe operation and use before it is used on each work shift. The visual inspection shall consist of all of the following procedures:

- (a) Visual inspection for all of the following:
 - (i) Cracked welds.
 - (ii) Bent or broken structural members.
 - (iii) Hydraulic or fuel leaks.
 - (iv) Damaged controls and cables.
 - (v) Loose wires.
 - (vi) Tire condition.
 - (vii) Fuel and hydraulic fluid levels.
 - (viii) Slippery conditions on the platform.

- (b) Operate all platform and ground controls to ensure that they perform their intended function.
- (2) Before the aerial work platform is used, and during use on the job site/work place, the operator shall inspect for all of the following:
 - (a) Ditches.
 - (b) Drop-offs.
 - (c) Holes.
 - (d) Bumps and floor obstructions.
 - (e) Debris.
 - (f) Overhead obstructions.
 - (g) Power lines.
 - (h) Similar conditions to those specified in subdivisions (a) to (g) of this subrule. The area around the aerial work platform shall also be inspected to assure clearance for the platform and other parts of the unit.
- (3) All unsafe items found as a result of the inspection of the aerial work platform or work area shall be corrected before further use of the aerial work platform.
- (4) The employer shall ensure before the commencement of operations near power lines and when the clearances cannot be maintained as specified in Tables 1-3, that the owner, owner representative, or utility are notified with all pertinent information about the job.
- (5) Any overhead wire shall be considered to be an energized line until the owner of the line, his or her authorized representative, or a utility representative assures one of the following:
 - (a) The line is de-energized and has been visibly grounded.
 - (b) The line is insulated for the system voltages and the task will not compromise the insulation of the conductor and/or cause an electrical hazard.

CONSTRUCTION, TESTING AND USE PROVISIONS

R 408.15821. Construction, modification, and remounting.

Rule 5821. (1) Aerial work platforms modified, remounted, designed, constructed, and tested after December 28, 1974, but before the effective date of this rule, shall be in compliance with the requirements of the following applicable American National Standards Institute Standards:

- (a) ANSI standard A92.2, "Standard for Vehicle-Mounted Elevating and Rotating Work Platforms," 1969 edition.
- (b) ANSI standard A92.3, "Manually Propelled Elevating Work Platforms", 1990 edition.
- (c) ANSI standard A92.5, "Boom-Supported Elevating Work Platforms", 1992 edition.
- (d) ANSI standard A92.6, "Self-Propelled Elevating Work Platforms", 1999 edition.

These standards are adopted by reference in R 408.15810.

(2) A permanent label or tag shall be affixed to an aerial work platform modified, remounted, designed, constructed, or tested after March 28, 1975, but before the effective date of these rules, certifying compliance with subrule (1) of this rule.

(3) Aerial work platforms modified, remounted, designed, constructed, and tested, after January 1, 2007, shall be in compliance with the requirements of the following applicable American National Standards Institute Standards:

- (a) ANSI standard A92.2, "Vehicle-Mounted Elevating and Rotating Aerial Devices", 2002 edition.
- (b) ANSI standard A92.3, "Manually Propelled Elevating Aerial Platforms", 2006 edition.
- (c) ANSI standard A92.5, "Boom-Supported Elevating Work Platforms", 2006 edition.

- (d) ANSI standard A92.6, "Self-Propelled Elevating Work Platforms", 1999 edition.

These standards are adopted by reference in R 408.15810.

(4) An aerial work platform shall bear a permanent plate stating the designed rating capacity.

(5) An aerial work platform shall be mounted on a vehicle capable of sustaining, or reinforced to sustain, the imposed load. The vehicle shall be a stable support for the aerial device.

(6) The lifting and outrigger system of an aerial work platform shall be equipped with a means, such as but not limited to, a pilot operated check valve to ensure that the system will not permit the work platform to drop in a free fall in event of a power or hydraulic line failure.

(7) Aerial work platforms shall not be field-modified for uses other than those intended by the manufacturer, unless the modification has been certified in writing by the manufacturer or by any other equivalent entity, such as a nationally recognized testing laboratory, to be in compliance with the applicable ANSI standard and this rule, and to be at least as safe as the equipment was before modification.

R 408.15823 RESCINDED.

R 408.15824 RESCINDED.

R 408.15825 Controls.

Rule 5825. (1) All of the following information shall be clearly marked in a permanent manner on each aerial work platform:

- (a) Special workings, cautions, or restrictions necessary for operation.
- (b) Rated work load.
- (c) A clear statement if the aerial work platform is electrically insulated.

(2) Directional controls shall be in compliance with all of the following provisions:

- (a) Be of the type that will automatically return to the off or neutral position when released.
- (b) Be protected against inadvertent operation.
- (c) Be clearly marked as to their intended function.

(3) An overriding control shall be provided in the platform which must be continuously activated for platform directional controls to be operational and which automatically returns to the off position when released.

(4) Articulating, extensible boom platforms, or both, primarily designed as personnel carriers, shall be equipped with both upper and lower controls.

(5) Upper controls shall be located within reach of the operator.

(6) Aerial work platforms shall be equipped with emergency controls at ground level.

(7) Emergency ground level controls shall be clearly marked as to their intended function and be capable of overriding the platform controls.

(8) Rotating shafts, gears, and other moving parts that are exposed to contact shall be guarded as prescribed in general industry safety standard, Part 7. "Guards for Power Transmission", R 408.10701 to R 408.10765.

(9) Attachment points shall be provided for fall protection devices for personnel who occupy the platform on aerial work platforms described in the provisions of R 408.15802 (a) and (c). (See figures 1 and 3).

R 408.15830. RESCINDED.

R 408.15831. Inspection, maintenance; testing.

Rule 5831. (1) An employer shall comply with all of the following requirements:

- (a) Each aerial work platform shall be inspected, maintained, repaired, and kept in proper working condition in accordance with the manufacturers or owner's operating or maintenance and repair manual or manuals.
- (b) Any aerial work platform found not to be in a safe operating condition shall be removed from service until repaired. All repairs shall be made by an authorized person in accordance with the manufacturer's or owner's operating or maintenance and repair manual or manuals.
- (c) If the aerial work platform is rated and used as an insulated aerial device, the electrical insulating components shall be tested for compliance with the rating of the aerial work platform in accordance with ANSI standard A92.2 2002 edition "Vehicle-Mounted Elevating and Rotating Aerial Devices," which is adopted by reference in R 408.15810. Testing shall comply with all of the following provisions:
 - (i) The test shall be performed not less than annually.
 - (ii) Written, dated, and signed test reports shall be made available by the employer for examination by a department representative.
 - (iii) The insulated portion of an aerial device shall not be altered in any manner that might reduce its insulating value.
- (d) All danger, caution, and control markings and operational plates shall be legible and not obscured.

R 408.15832. Electrical hazards.

Rule 5832. (1) The employer shall ensure that an aerial work platform shall be operated so that the distances from energized power lines and equipment prescribed in Table 1 are maintained, except for the following:

- (a) As prescribed in subrule (2) of this rule addressing tree trimming.
- (b) As prescribed in subrule (3) of this rule addressing telecommunications.
- (c) Where insulating barriers are not a part of or an attachment to the aerial device that has been erected to prevent physical contact with the lines.

(2) A qualified lineman or a qualified line clearance tree trimmer, as prescribed in General Industry Safety Standard Part 53 "Tree Trimming and Removal" R 408.15301 to R 408.15363, shall maintain distances as prescribed in Table 2 when performing work from an aerial work platform on or near an exposed power line unless any of the following conditions exist:

- (a) The employee is insulated or guarded from the energized part by gloves or gloves and sleeves, as provided for and prescribed in General Industry Safety Standard Part 33 "Personal Protective Equipment," R 408.13301 to R 408.13398.
- (b) The employee is insulated, isolated, or guarded from any other conductive part.
- (c) The energized part is insulated from the employee.

(3) A qualified telecommunications employee shall maintain the distances prescribed in Table 3 when working from an aerial lift, unless the employee is insulated, isolated, or guarded from any other conductive part or the energized part is insulated from the employee.

(4) Employees shall use insulated bucket, gloves, and sleeves that are rated at more than the voltage to be worked on or that with which they might come into contact, to comply with subrules (2) and (3) of this rule.

(5) The clearances, as prescribed in Tables 1-3, do not apply when the owner of the line or his or her authorized representative, or a utility representative assures that the conductor is insulated for the system voltages and the task will not compromise the insulation of the conductor and/or cause an electrical hazard.

(6) Tables 1, 2, and 3 read as follows:

**Table 1
Minimum Clearance Distances for Equipment**

Voltage	Clearance With Boom Raised	Clearance Boom Lowered and No Load in Transit
To 50 kV	10 feet	4 feet
Over 50 kV	10 feet + .4 inch per each 1 kV over 50 kV	10 feet
50 to 345 kV	--	10 feet
346 to 750 kV	--	15 feet

**Table 2
Minimum Working Distances for Qualified Line-Clearance Tree Trimmers and Qualified Linemen**

Voltage Range Phase to Phase (kilovolts)	Minimum Working Distance
2.1 to 15.0	2 feet 0 inches (61 cm)
15.1 to 35.0	2 feet 4 inches (71 cm)
35.1 to 46.0	2 feet 6 inches (76 cm)
46.1 to 72.5	3 feet 0 inches (91 cm)
72.6 to 121.0	3 feet 4 inches (102 cm)
138.0 to 145.0	3 feet 6 inches (107 cm)
161.0 to 169.0	3 feet 8 inches (112 cm)
230.0 to 242.0	5 feet 0 inches (152 cm)
345.0 to 362.0	*7 feet 0 inches (213 cm)
550.0 to 552.0	*11 feet 0 inches (335 cm)
700.0 to 765.0	*15 feet 0 inches (457 cm)

*Note: For 345-362 kV., 500-552 kV., and 700-765 kV., the minimum working distance and the minimum clear hot stick distance may be reduced that such distances are not less than the shortest distance between the energized part and a grounded surface.

**Table 3
Minimum Approach Distances for Qualified Telecommunications Employees**

Voltage Range (Nominal Phase to Phase)	Minimum Approach Distances
300 V and less	1 foot - 0 inches (30.5 cm)
Over 300 V, not over 750 V	1 foot - 6 inches (46 cm)
Over 750 V, not over 2 kV	2 feet - 0 inches (61 cm)
Over 2 kV, not over 15 kV	3 feet - 0 inches (91 cm)
Over 15 kV, not over 37 kV	3 feet - 6 inches (107 cm)
Over 37 kV, not over 87.5 kV	4 feet - 0 inches (122 cm)
Over 87.5 kV, not over 121 kV	4 feet - 6 inches (137 cm)
Over 121 kV, not over 140 kV	--

R 408.15833 Vehicles; traffic control.

Rule 5833. (1) Before moving a vehicle supporting an aerial ladder for highway travel, employees shall secure ladders in the lower position, and shall use the manually operated device at the base of the ladder, or other effective means to prevent elevation or rotation of the ladder.

(2) Before moving a vehicle supporting an aerial lift for travel, employees shall inspect the boom to ensure that it is properly cradled and the outriggers are in the stowed position, except as provided in subrule (3) of this rule.

(3) When a boom is elevated with employees in working position, the vehicle supporting an aerial device shall not be moved unless the equipment is specifically designed for this type of operation and meets the requirements of R 408.15821.

(4) Before and during travel, except as provided for horizontal movement in R 408.15839 (9), an operator shall do all of the following:

- (a) Inspect to see that booms, platforms, aerial ladders, or towers are properly cradled or secured.
- (b) Ensure that outriggers are in a stored position.
- (c) Limit travel speed according to the following factors:
 - (i) Condition of the surface.
 - (ii) Congestion.
 - (iii) Slope.
 - (iv) Location of personnel.
 - (v) Other hazards.

(5) An employer shall ensure that operators of an aerial work platform over or adjacent to any public or private roadway maintain adequate clearances of all portions of the aerial work platform to prevent being struck by vehicular traffic.

(6) When aerial work platforms are in use, all traffic control requirements shall be in compliance with Part 6 of the 2005 Michigan Manual on Uniform Traffic Control Devices (MMUTCD), which is adopted in R 408.15810, and Construction Safety Part 22. Signals, Signs, Tags, and Barricades, R 408.42201 to R 408.42243.

R 408.15836. Fall protection.

Rule 5836. (1) The employer shall provide a safety harness that has a lanyard which is in compliance with construction safety standard Part 45. "Fall Protection", R 408.44501 to R 408.44502 and which is affixed to attachment points provided and approved by the manufacturer. Any occupant of an aerial work platform described in the provisions of R 408.15802(a) and (c) and figures 1 and 3 shall use a safety harness. A fall arrest system shall only be used where the aerial lift is designed to withstand the vertical and lateral loads caused by an arrested fall.

(2) An employee may use a body belt with a restraint device with the lanyard and the anchor arranged so that the employee is not exposed to any fall distance. An employee is required to use a restraint device where the aerial lift cannot withstand the vertical and lateral loads imposed by an arrested fall.

(3) An employee shall be prohibited from belting off to an adjacent pole, structure, or equipment while working from an aerial work platform.

(4) An employer shall not allow employees to exit an elevated aerial work platform, except where elevated work areas are inaccessible or hazardous to reach. Employees may exit the platform with the knowledge and consent of the employer. When employees exit to unguarded work areas, fall protection shall be provided and used as prescribed in construction safety standard Part 45. "Fall Protection", R 408.44501 to R 408.44502.

(5) An employer shall provide for prompt rescue of employees in the event of a fall or shall assure that employees are able to rescue themselves.

R 408.15839. Operating procedures.

Rule 5839. (1) The aerial work platform shall be used only in accordance with the manufacturers or owners operating instructions and safety rules.

(2) The designed rated capacity for a given angle of elevation shall not be exceeded.

(3) A proximity-warning device may be used, but shall not be used to avoid meeting the requirements of this rule.

(4) The manufacturer's rated load capacity shall not be exceeded. The employer shall ensure that the load and its distribution on the platform are in accordance with the manufacturer's specifications. The aerial work platform rated load capacity shall not be exceeded when loads are transferred to the platform at elevated heights.

(5) Only employees, their tools, and necessary materials shall be on or in the platform.

(6) The guardrail system of the platform shall not be used to support any of the following:

- (a) Materials.
- (b) Other work platforms.
- (c) Employees.

(7) Employees shall maintain firm footing on the platform while working on the platform. The use of railings, planks, ladders, or any other devices on the platform for achieving additional height is prohibited.

(8) Fuel gas cylinders shall not be carried on platforms that would allow the accumulation of gases.

(9) Only aerial work platforms that are equipped with a manufacturer's installed platform controls for horizontal movement shall be moved while in the elevated position.

(10) Before and during driving while elevated, an operator of a platform shall do both of the following:

- (a) Look in the direction of, and keep a clear view of, the path of travel and make sure that the path is firm and level.
- (b) Maintain a safe distance from all of the following:
 - (i) Obstacles.
 - (ii) Debris.
 - (iii) Drop-offs.
 - (iv) Holes.
 - (v) Depressions.
 - (vi) Ramps.
 - (vii) Overhead obstructions.
 - (viii) Overhead electrical lines.
 - (ix) Other hazards to safe elevated travel.

(11) Outriggers or stabilizers, when provided, are to be used in accordance with the manufacturer's instruction. Brakes shall be set and outriggers and stabilizers shall be positioned on pads or a solid surface.

(12) Aerial work platforms shall be elevated only when on a firm and level surface or within the slope limits allowed by the manufacturer's instructions.

(13) A vehicle-mounted aerial work platform (figure 1) shall have its brakes set before elevating the platform.

(14) A vehicle-mounted aerial work platform (figure 1) shall have wheel chocks installed before using the unit on an incline.

(15) Climbers shall not be worn while working from an aerial device unless gaff guards are provided.

(16) Platform gates shall be closed while the platform is in an elevated position.

(17) Altering, modifying, or disabling safety devices or interlocks is prohibited.

(18) Care shall be taken to prevent rope, electric cords, hoses, or the equivalent, from becoming entangled in the aerial platform.

(19) A platform operator shall ensure that the area surrounding the aerial work platform is clear of personnel and equipment before lowering the platform.

(20) The aerial work platform shall not be positioned against another object to steady the platform.

(21) The aerial work platform shall not be operated from a position on a truck, trailer, railway car, floating vessel, scaffold, or similar equipment.

(22) The boom and platform of the aerial work platform shall not be used to move or jack the wheels off the ground unless the machine is designed for that purpose by the manufacturer.

(23) If the platform or elevating assembly becomes caught, snagged, or otherwise prevented from normal motion by adjacent structures or other obstacles so that control reversal does not free the platform, all employees shall exit from the platform before attempts are made to free the platform.

(24) Stunt driving and horseplay are prohibited.

R 408.15842. Figures.

Rule 5840. Figures 1, 2, 3, and 4 are as follows:

**FIGURE 1
VEHICLE-MOUNTED ELEVATING WORK PLATFORM**

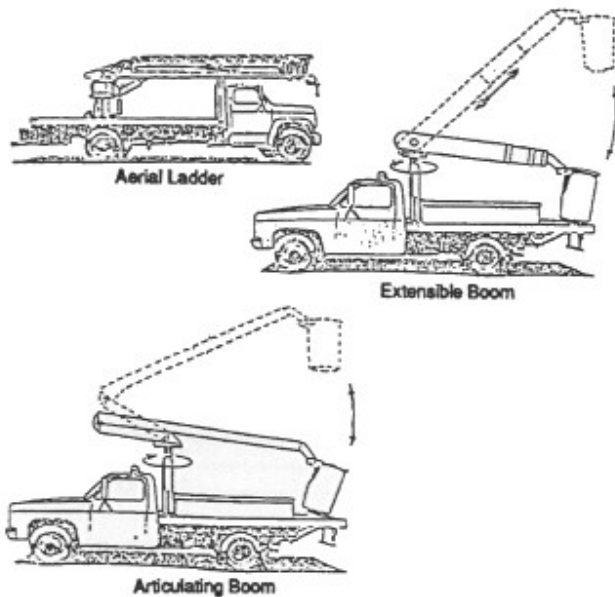

**FIGURE 3
BOOM-SUPPORTED ELEVATING WORK PLATFORMS**

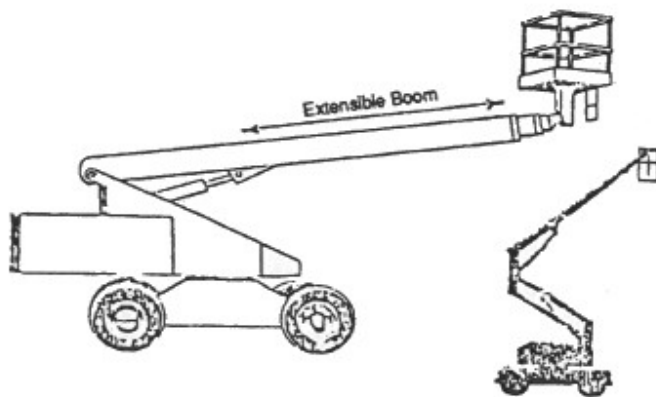

**FIGURE 2
MANUALLY PROPELLED ELEVATING WORK PLATFORMS**

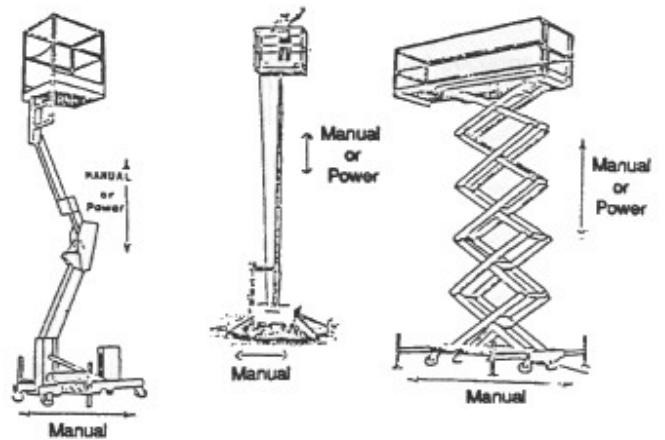

**FIGURE 4
SELF-PROPELLED ELEVATING WORK PLATFORMS**

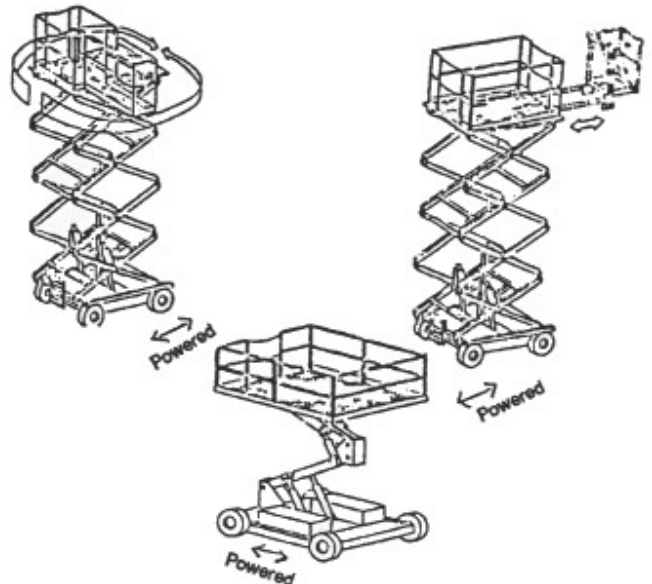



For further information contact
Michigan Occupational Safety and Health Administration
PO Box 30643
Lansing, Michigan 48909-8143
Ph: 517.322.1814
Fx: 517.322.1775

The Department of Energy, Labor & Economic Growth will not discriminate against any individual or group because of race, sex, religion, age, national origin, color, marital status, disability, or political beliefs.. Auxiliary aids, services and other reasonable accommodations are available upon request to individuals with disabilities.