



DEPARTMENT OF LICENSING AND REGULATORY AFFAIRS
DIRECTOR'S OFFICE
GENERAL INDUSTRY STANDARDS

Filed with the Secretary of State on November 1, 1974 (as amended October 28, 1976)
(as amended May 11, 1981) (as amended May 17, 1983) (as amended June 23, 1992) **(as amended June 4, 2008)**

These rules become effective 14 days after filing with the Secretary of State

(By authority conferred on the director of the department of labor and economic growth by sections 16 and 21 of 1974 PA 154, and Executive Reorganization Order Nos. 1996-2 and 2003-1, MCL 408.1016, 408.1021, 445.2001, and 445.2011)

R 408.10501, R 408.10502, R 408.10511, R 408.10513, R 408.10526, R 408.10528, R 408.10532, R 408.10546, R 408.10561, R 408.10565, R 408.10568, R 408.10569, R 408.10575, and R 408.10592, of the Michigan Administrative Code, are amended, and R 408.10509 is added, and R 408.10547 is rescinded as follows:

PART 5. SCAFFOLDING

TABLE OF CONTENTS

R 408.10501. Scope.....	2	R 408.10561. Construction and modification; requirements for buildings utilizing working platforms for maintenance; tie-in guides.....	13
R 408.10502. Applicability for powered platforms.....	2	R 408.10562. Intermittent stabilization systems.....	13
R 408.10503. Definitions; A to D.....	2	R 408.10563. Button guide stabilization systems.....	14
R 408.10504. Definitions; F to L.....	2	R.408.10564. Design of installation.....	14
R 408.10505. Definitions; M to O.....	2	R 408.10565. Roof cars; carriages; suspension methods...	14
R 408.10506. Definitions; P, R.....	3	R 408.10566. Outriggers.....	15
R 408.10507. Definitions; S.....	3	R 408.10567. Davits.....	15
R 408.10508. Definitions; T, W.....	3	R 408.10568. Perimeter guarding; equipment stops; maintenance access: elevated track system walkway and guardrail system; platform access and egress safety; certain anchors, fasteners, and structures to be corrosion resistant; cable installation; emergency action plan; repairs or major maintenance to parts of building providing primary support.....	15
R 408.10509. Adoption of standards by reference; access to other MIOSHA rules.....	3	R 408.10569. Electrical requirements.....	16
R 408.10511. General requirements.....	4	R 408.10570. Controls and interlocks.....	16
R 408.10512. Planking.....	4	R 408.10571. Safety factors.....	16
R 408.10513. Construction.....	4	R 408.10572. Working platforms.....	16
R 408.10521. Wood pole scaffolds generally.....	5	R 408.10573. Inspections and tests.....	16
R 408.10522. Independent pole scaffold, specific.....	7	R 408.10574. Maintenance.....	16
R 408.10523. Single pole scaffold, specific.....	7	R 408.10575. Hoisting machines; suspended equipment; 2 and 4-point suspended working platforms; single-point suspended platforms; ground-rigged working platforms; intermittently stabilized platforms; button-guide stabilized platforms; supported equipment; suspension wire ropes and rope connections.....	17
R 408.10524. Suspension scaffolding.....	7	R 408.10576. Tags.....	19
R 408.10525. Swinging scaffolds.....	8	R 408.10577. Compliance with material electrical code required; exception; electrical runway conductors; cable protection; electrical overload protection.....	19
R 408.10526. Outrigger's scaffolds.....	9	R 408.10578. Installation and alteration; inspections and tests.....	20
R 408.10527. Horse scaffolds.....	9	R 408.10579. Inspection of related building supporting structures; equipment inspection and testing intervals; certification record; employer inspection of platforms.....	20
R 408.10528. Ladder jack scaffolds.....	9	R 408.10580. Intervals of maintenance inspections and tests; certification record.....	20
R 408.10529. Boatswain's chair.....	10	R 408.10581. Special inspection of governors and secondary brakes.....	20
R 408.10530. Bricklayer's square scaffold.....	10		
R 408.10531. Carpenter's bracket scaffold.....	10		
R 408.10532. Working surfaces; steep slopes.....	10		
R 408.10533. Roofing brackets and crawling boards.....	10		
R 408.10534. Needle beam scaffold.....	10		
R 408.10535. Window jack scaffold.....	10		
R 408.10541. General.....	11		
R 408.10542. Tube and coupler-type scaffolding.....	11		
R 408.10543. Welded frame type scaffolds.....	12		
R 408.10544. Mobile scaffolds.....	12		
R 408.10545. Wire rope scaffolding.....	12		
R 408.10546. Powered and manual mobile elevating platforms.....	12		
R 408.10547. Rescinded.....	12		
R 408.10548. Powered hoisting machine.....	13		
R 408.10549. Manual powered hoisting devices.....	13		
R 408.10550. Hydraulic and pneumatic systems.....	13		

R 408.10582. Wire rope; reinforcement; use of metal thimble, end fittings; requirements for use of wire clips; cutting preparation; lubrication; use of suspension wire rope to follow procedures recommended by manufacturer; inspection of suspension wire rope; certification record...	21
R 408.10583. Fiber rope; inspection; storage; drying of wet rope; use prohibited under certain conditions; replacement; use of thimble.....	21
R 408.10584. Synthetic rope; inspection; condition of use; replacement; use of thimble.....	21
R 408.10585. Hoist inspection; general maintenance; cleaning.....	22
R 408.10586. Periodic resocking of wire rope fastenings....	22

R 408.10587. Roof systems; maintenance.....	22
R 408.10588. Building face guiding members; maintenance.....	22
R 408.10589. Rendering safety devices inoperative prohibited; exception.....	22
R 408.10590. Platform operator training.....	22
R 408.10591. Platform load; work on platforms covered with certain materials prohibited; exception; protective precautions; operation of platform under certain wind conditions prohibited; use of anemometer required; accumulation of tools, materials, or debris prohibited; stabilizer ties.....	22
R 408.10592. Personal fall protection.....	23

GENERAL PROVISIONS

R 408.10501. Scope.

Rule 501. (1) This part applies to scaffolds and the use of material and equipment in conjunction with scaffolding around or about places of employment.

(2) Powered and manual mobile elevating platforms and self-propelled vehicle mounted elevating and rotating platforms are not included in these rules but are provided for in general industry safety standard Part 58. "Aerial Work Platforms," R 408.15801 to R 408.15842.

R 408.10502. Applicability for powered platforms.

Rule 502. (1) These rules apply to all new permanent installations for powered platforms and modifications to existing buildings that affect the structural integrity of the building exterior, tie-in guides and attachments, and the supporting structure for the powered platforms.

(2) Employers shall ensure compliance with these rules for any powered platform that is powered by a source other than electricity except for those rules that govern the electrical power source. The alternative power source shall be outfitted with protective devices that are equivalent to the protection that is provided by rules pertaining to an electrical power source.

(3) Scaffolds that are not covered by this part shall be as safe or safer for employees as scaffolds that are regulated by these rules.

(4) Permanent installations shall be in compliance with the provisions of 29 C.F.R. §1910.66, 'Powered Platforms, Manlifts, and Vehicle-Mounted Work Platforms Appendix D – Existing Installations (Mandatory). The following standards that are cited in 29 C.F.R. §1910.66, appendix D, are as follows and adopted by reference in R 408.40509.

- ANSI A120.1 - 1970 edition, entitled "Safety Requirements for Powered Platforms for Exterior Building Maintenance."
- Subpart S, referenced in 29 C.F.R. §1910.66(c)(22)(i), means general industry safety standard Part 39 'Design Safety Standards for Electrical Systems,' R 408.13901 to R 408.13902.
- ANSI A12.1 – 1967 edition, entitled "Safety Requirements for Floor and Wall Openings, Railings and Toeboard."

R 408.10503. Definitions; A to D.

Rule 503. (1) "Anemometer" means an instrument for measuring wind velocity.

(2) "Angulated roping" means a suspension method where the upper point of suspension is inboard from the attachments on the suspended unit, thus causing the suspended unit to bear against the face of the building.

(3) "Bearer," sometimes called a "putlog," means a bearing cross member that supports the floor of a scaffold.

(4) "Boatswain's chair" means a seat that is supported by slings which are attached to a suspended rope.

(5) "Bricklayer's square scaffold" means a scaffold that is composed of framed wood squares which support a platform.

(6) "Building face roller" means a rotating cylindrical member that is designed to ride on the face of the building wall to prevent the platform from abrading the face of the building and to assist in stabilizing the platform.

(7) "Carpenter's bracket scaffold" means a scaffold which is triangular in shape and which is made of wood or metal brackets that are secured to a structure to hold a platform.

(8) "Coupler" means a device which is made of drop-forged steel, malleable iron, structural grade aluminum, or a material of equivalent strength and which is used to lock or join component parts of a tubular scaffold.

(9) "Crawling board" means a plank which has cleats that are spaced and secured at equal intervals for use on roofs, but which is not designed to hold or carry material.

(10) "Davit" means a device which is used singly or in pairs and which is for suspending a powered platform from work, storage, or rigging locations on the building being.

R 408.10504. Definitions; F to L.

Rule 504. (1) "Fall prevention device" means a mechanism attached to a lifeline which will stop uncontrolled descent if an employee falls from an elevated position.

(2) "Heavy duty scaffold" means a scaffold designed and constructed to carry a uniformly distributed load of 75 pounds per square foot.

(3) "Horse scaffold" means a scaffold in which the platform or floor is supported by saw horses.

(4) "Independent pole scaffold" means a scaffold having a platform supported by ledgers attached at both ends to solid uprights independent of other support.

(5) "Interior hung scaffold," means a scaffold suspended inside a building from the ceiling or roof structure.

(6) "Ladder jack scaffold" means a platform supported by metal brackets attached to the rungs or rails of a ladder.

(7) "Ledger" means a horizontal support extending from post to post at right angles to the bearer and supports the bearer.

(8) "Light duty scaffold" means a scaffold designed and constructed to carry a uniformly distributed load of 25 pounds per square foot.

R 408.10505. Definitions; M to O.

Rule 505. (1) "Maximum intended load" means the total weight of the employees, materials, equipment and scaffold.

(2) "Medium duty scaffold" means a scaffold designed and constructed to carry a uniformly distributed load of 50 pounds per square foot.

(3) **"Mobile elevating platform"** means a type of freestanding scaffolding which can be manually moved horizontally from 1 area to another and raised or lowered manually or with power to predetermined heights.

(4) **"Mobile scaffold"** means a tube and coupler or welded frame type scaffold mounted on casters or wheels.

(5) **"Needle beam scaffold"** means a platform which rests on 2 beams which are supported at the end by ropes.

(6) **"Nominal"** means dressed sizes of lumber.

(7) **"Outrigger scaffold"** means a scaffold supported by beams extending from a building and fastened to the frame-work or floor inside a building.

R 408.10506. Definitions; P, R.

Rule 506. (1) "Pick" means a scaffold platform that is manufactured, assembled, and sold as a ready-to-use item.

(2) **"Pinch point"** means a point at which it is possible to be caught between the moving parts of a machine or between moving and stationary parts of a machine.

(3) **"Plank"** means a piece of lumber, as prescribed in R 408.10512, which is sold by a lumber dealer and which does not have stringers or cross braces when purchased.

(4) **"Powered hoisting machine"** means a mechanical, electrical, hydraulic, or pneumatically operated device that is used to raise or lower a swing or suspension scaffold or a mobile elevating platform.

(5) **"Powered platform"** means scaffolding equipment that consists of a permanently installed, power-operated working platform and a roof car or other suspension means.

(6) **"Registered professional engineer"** means a person who has been duly and currently registered and who is licensed by an authority within the United States or its territories to practice the profession of engineering.

(7) **"Roof bracket"** means a bracket which is used on a slope roof to support a plank and which can be fastened to the roof or secured by ropes over the ridge to a fixed object.

(8) **"Roof car"** means a structure which is for suspending a working platform and which provides for the platform's horizontal movement to work positions.

R 408.10507. Definitions; S.

Rule 507. (1) "Safety factor" means a ratio of breaking strength of a piece of material or object to the maximum designed load or stress that is applied when in use.

(2) **"Scaffold"** means an elevated work platform which is for supporting both employees and materials and which is temporary in nature.

(3) **"Scaffold ladder"** means a type of ladder that is attached to scaffolding for access to the platform.

(4) **"Single-pole scaffold"** means a scaffold that has a platform which is supported by ledgers attached to a row of solid uprights at 1 end and a wall or building at the other end.

(5) **"Stability factor"** means the ratio of the stabilizing moment to the overturning moment.

(6) **"Stabilizer tie"** means a flexible line that connects the building anchor and the suspension wire rope which supports the platform.

(7) **"Suspension scaffold"** means a platform that is supported by bearers with each bearer supported at 2 or more points by wire rope from thrust outs that are arranged and operated to permit the raising and lowering of the platform.

(8) **"Swing scaffold"** means a platform which is supported by hangers at not more than 2 points and which is suspended from overhead supports to permit the raising and lowering of the platform.

R 408.10508. Definitions; T, W.

Rule 508. (1) "Thrust out," sometimes called an "outrigger," means a beam that extends out from a building to support a scaffolding platform.

(2) **"Tie-in guides"** means the portion of a building that provides continuous positive engagement between the building and a suspended or supported unit during its vertical travel on the face of the building.

(3) **"Tube and coupler-type scaffold"** means an assembly of tubing that serves as posts, bearers, ledgers, braces, and special couplers which serve to connect the various parts.

(4) **"Welded frame-type scaffold"** means a sectional or frame scaffold that is built up of prefabricated welded sections which consists of posts and intermediate members connected by braces.

(5) **"Window jack scaffold"** means a platform which extends through a window opening and which is secured to the structure and supported by braces.

(6) **"Wire rope scaffold"** means a scaffold that consists of 2 lengths of wire rope strung between building structural members upon which a plank with a standard barrier is supported for special usage in servicing unlimited areas where the use of a conventional scaffold is not practical.

(7) **"Working load"** means the total weight of employees, materials, and equipment.

(8) **"Working platform"** means a suspended structure which is used for vertical travel and which either may be powered from a roof car or have its own raising and lowering powered mechanism.

R 408.10509. Adoption of standards by reference; access to other MIOSHA rules.

Rule 509. (1) The standards specified in this rule, except for the standards specified in subrule (2) of this rule, are adopted in these rules by reference.

(a) The following standards are available from IHS/Global Engineering Documents, 15 Inverness Way East, Englewood, Colorado, 80112, USA, telephone number: 1-800-854-7179 or via the internet at web-site: <http://global.ihs.com>; at a cost as of the time of adoption of these rules, as stated in this subrule:

(i) American National Society Institute Standard ANSI A120.1 'Safety Requirement for Powered Platforms for Exterior Building Maintenance,' 1970 edition, also known as American Society of Mechanical Engineers Standard ASME A120.1 'Safety Requirements Powered Platforms and Traveling Ladders and Gantries for Building Maintenance,' 1970 edition. Cost \$20.00

(ii) American National Society Institute Standard ANSI A12.1 'Safety Requirements for Floor and Wall Openings, Railings and Toeboard,' 1967 edition. Cost \$20.00.

(b) The Code of Federal Regulations, Title 29, Occupational Safety And Health Standard 1910.66 "Powered Platforms, Manlifts, And Vehicle-Mounted Work Platforms," Appendix D "Existing Installations (Mandatory)" is available from the U.S. Government Printing Office, Washington DC, 20402; telephone number (202) 512-1800 or through the GPO website - <http://bookstore.gpo.gov>. Cost. \$11.00.

(c) The standards adopted in subrule 1(a) and (b) of this rule are also available for inspection at the Department of Labor and Economic Growth,

MIOSHA Standards Section, 7150 Harris Drive, P.O. Box 30643, Lansing, Michigan, 48909-8143.

- (d) Copies of the standards adopted in subrule (1)(a) and (b) of this rule may be obtained from the publisher or may also be obtained from the Department of Labor and Economic Growth, MIOSHA Standards Section, 7150 Harris Drive, P.O. Box 30643, Lansing, Michigan, 48909-8143, at the cost charged in subrule (1)(a) and (b), of this rule, plus \$20 for shipping and handling.

(2) The following Michigan Occupational Safety and Health Standards are referenced in these rules. Up to 5 copies of these standards may be obtained at no charge from the Michigan Department of Labor and Economic Growth, MIOSHA Standards Section, 7150 Harris Drive, P.O. Box 30643, Lansing, Michigan, 48909-8143 or via the internet at web-site: www.michigan.gov/mioshastandards. For quantities greater than 5, the cost, as of the time of adoption of these rules, is 4 cents per page.

- (a) General Industry Safety Standard Part 2. Floor and Wall Openings, Stairways and Skylights, R 408.10201 to R 408.10241.
- (b) General Industry Safety Standard Part 3. Fixed Ladders, R 408.10301 to R 408.10372.
- (c) General Industry Safety Standard Part 4. Portable Ladders, R 408.10401 to R 408.10456.
- (d) General Industry Safety Standard Part 7. Guards for Power Transmission, R 408.10701 to R 408.10765.
- (e) General Industry Safety Standard Part 8. Portable Fire Extinguishers, R 408.10801 to R 408.10839.
- (f) General Industry Safety Standard Part 21. Powered Industrial Trucks, R 408.12101 to R 408.12193.
- (g) General Industry Safety Standard Part 33. Personal Protective Equipment, R 408.13301 to R 408.13398.
- (h) General Industry Safety Standard Part 39. Design Safety Standards for Electrical Systems, R 408.13901 to R 408.13902.
- (i) General Industry Safety Standard Part 58. Aerial Work Platforms, R 408.15801 to R 408.15842.

R 408.10511. General requirements.

Rule 511. (1) When required by this part, a safety belt, lanyard, and lifeline shall be provided to employees and used as prescribed in General Industry Safety Standard Part 33. "Personal Protective Equipment," R 408.13301 to R 408.13398.

(2) Except where a ladder, as prescribed in General Industry Safety Standard Part 4. "Portable Ladders," R 408.10401 to R 408.10456, or a self-propelled vehicle mounted elevating platform is furnished, an employee engaged in work that cannot be done safely from the ground or from solid construction shall be provided a scaffold from which to work or shall wear a safety harness and lifeline.

(3) A scaffold, part, or material used in scaffolding shall not be furnished or used if it has a defect, which would create a hazard to an employee. A scaffold damaged or weakened from any cause shall be repaired before use.

(4) A scaffold shall not be loaded to more than the designed working load.

(5) Materials being hoisted to a scaffold shall have a tag line when necessary to control the load.

(6) Tools, materials, and debris shall not be permitted to accumulate in a quantity to cause a hazard.

(7) Precautions shall be taken to protect scaffold members, including suspension ropes, when using a heat producing process.

(8) A lifeline and safety belt shall be used where an employee is required to crawl out on a thrust out or projecting beam.

(9) An employer shall not permit an employee to work on a scaffold outdoors during a storm or high wind, or on a scaffold covered with ice or snow, except when performing emergency service. When performing emergency service, safeguards such as, but not limited to, lanyards and safety belts shall be used by the employee.

(10) Scaffolding endangered by a truck or other moving equipment shall be protected by a warning device, or barrier, or both.

(11) A scaffold shall not be altered or moved horizontally while it is in use or is being occupied unless the scaffold is specifically designed for occupied horizontal travel.

(12) Fiber rope used for or near any work involving the use of corrosive substances or chemicals shall be treated or protected against deterioration.

R 408.10512. Planking.

Rule 512. (1) Planking shall be scaffold grade and capable of supporting the intended load. The maximum span for a 2-by 10-inch or wider plank shall be as prescribed in table 1.

(2) Planking shall comply with all of the following:

- (a) Extend over the end bearer not less than 6 inches, but not more than 12 inches.
- (b) Be cleated or otherwise fastened to prevent shifting and be uniform in thickness, except where lapped as prescribed in subrule (3) of this rule.
- (c) Consist of not less than 2 2-by 10-inch wide boards.

(3) Where planks are lapped, each plank shall lap its bearer not less than 6 inches which will provide minimum overlap of 12 inches.

(4) Where the ends abut each other, the butt joint shall be at the centerline of a pole and rest on separate bearers.

(5) A manufactured plank, or pick, shall be used as prescribed in the manufacturer's instructions.

(6) Planks shall be laid with their edges close together so as to prevent material and tools from falling.

(7) Where a scaffold turns a corner, the planks shall be laid to prevent tipping. The planks that meet the corner bearer at the angle shall be laid first, extending over the diagonally placed bearer far enough to have a good bearing, but not far enough to tip the planks running in the different direction shall be laid so as to extend over the rest on the first layer of planks.

(8) Table 1 reads as follows:

TABLE 1

Planking span Table	Material				
	Full thickness undressed lumber			Nominal thickness lumber	
Working load (p.s.f.)	25	50	75	25	50
Permissible span (ft.)	10	8	7	8	7

R 408.10513. Construction.

Rule 513. (1) A scaffold and its components shall have a designed safety factor of not less than 4 with the load figure including the total weight of materials, men, and scaffold. Load-carrying timber members for scaffold framing shall be not less than 1500 fiber, stress grade, construction grade lumber.

(2) A scaffold, except a ladder scaffold, boatswain's chair, or needle beam scaffold, 10 feet or more above floor or ground level, shall have a standard barrier and toeboard pursuant to rules R 408.10231 and R 408.10233 of General Industry Standard Part 2. "Floor and Wall Openings, Stairways, and Skylights." A life line and safety belt shall be used where a railing is required but not practical.

(3) A scaffold over a walk, aisle, or work area shall have the sides screened from toeboard to the top rail where an employee is required to work or pass under the scaffold.

(4) When work is being performed above a scaffold, overhead protection consisting of 2 inch planks laid tight, or equivalent material, shall be installed not more than 9 feet above the scaffold floor.

(5) Where access is not available directly from a structure, a wood scaffolding shall have a stair to the platform or portable ladder pursuant to General Industry Safety Standards Part 4. "Portable ladders," R 408.10401 to R 408.104560 or a fixed ladder pursuant to Part 3. "Fixed Ladders," R 408.10301 to R 408.10456, except that a cage is not mandatory for the fixed ladder. Use of a stair or fixed ladder shall not have a tendency to tip the scaffold.

(6) Manufactured scaffolding shall be equipped with a stair or a fixed ladder, mounted by a portable ladder, except that a cage is not mandatory for a fixed ladder. On manufactured scaffolding purchased after November 16, 1974, and equipped with a built-in fixed ladder or an attached scaffold ladder, the ladder shall be constructed of rungs not less than 12 inches long, uniformly spaced not less than 12 inches nor more than 16 1/2 inches from the center of 1 rung to another and the rung and component parts shall support a minimum of 300 pounds.

(7) Instead of the requirements for a stair, fixed ladder, or portable ladder, the intermediate horizontal members of a frame of a manufactured tubular welded frame scaffold may be used for access to, and egress from, the work platform if all of the following conditions are met:

- (a) All frames and component parts are compatible in design.
- (b) The intermediate horizontal members of a frame are a minimum of 16 inches in length.
- (c) The horizontal members of each frame shall be uniformly spaced and shall not exceed 17 inches center to center vertically.
- (d) When frames are connected vertically to one another, the distance between the bottom horizontal member of the upper end frame and the top horizontal member of the lower end frame shall be within 3 inches of the uniform spacing of the horizontal members of each frame.
- (e) The elevation to the lowest horizontal member of the bottom frame shall not exceed 21 inches from ground or floor.
- (f) Each horizontal member shall be capable of supporting 300 pounds applied at the member's midpoint without bending or cracking.
- (g) Each horizontal member shall be inspected for, and found free of cracks, bends, or bad welds.
- (h) The guardrail system located on the side where horizontal members of the scaffold frame are used for access to or egress from, a work platform shall be constructed as follows:
 - (i) The intermediate rail shall be omitted between the corner posts at access location.
 - (ii) The top rail shall be continuous between posts.
 - (iii) Only 1 employee at a time shall use a horizontal member of a frame as access to, or egress from, the workstation.

(8) Footing for a scaffold shall be sound, rigid, and capable of supporting the maximum intended load without settling or displacement. Objects such as barrels, boxes, loose brick, or concrete blocks shall not be used.

(9) Poles, legs, or uprights of a scaffold shall be plumb and shall be secured or braced to prevent swaying or displacement.

(10) Load-carrying timber members of a scaffold shall be a minimum of 1500 fiber, stress grade, construction grade lumber.

(11) Construction and attachment of a scaffold shall be such that there is no direct pull on the fasteners.

BUILT-UP SCAFFOLDS

R 408.10521. Wood pole scaffolds generally.

Rule 521. (1) When a wood pole is spliced, the ends shall be square and flat. Not less than 2 wood splice plates shall be secured to adjacent sides and shall be not less than 4 feet in length by 1 inch thick by the same width as the pole and have equal overlap to the joint. More than 1 consecutive splice per general level shall not be made (see figure 1).

(2) A pole scaffold shall be guyed or tied to the building or structure. Where the height or length is more than 25 feet, the scaffold shall be secured at intervals not more than 25 feet vertically and horizontally.

(3) Ledgers shall overlap the poles at each end by not less than 4 inches, be level, and be nailed to the inside of the poles. A ledger shall not be nailed less than 1 inch to the top edge.

(4) Two ledgers meeting at a pole shall be nailed to each other, and 2 ledgers meeting at a corner shall have 1 cut flush to the pole and the other nailed on the outside and overlap.

(5) A ledger shall not be spliced between poles. A spliced ledger shall be reinforced by a bearing block secured to the side of the pole to form a support for the ledger.

(6) A bearer shall be set with its greater dimension vertical and shall project 3 inches beyond the ledger and the inner and outer pole.

(7) Successive lengths of planking shall not abut on a single bearer and, where planks abut, 2 bearers shall be placed not more than 8 inches apart.

(8) When moving a work platform to a new level, the old platform shall remain in place until the new bearers are in place to receive the platform.

(9) A wood pole scaffold less than 60 feet in height shall use materials prescribed in tables 2 to 7. A scaffold more than 60 feet in height shall be designed by an engineer knowledgeable in scaffolds and erected as prescribed in the blueprints. A copy of the blueprint shall be on the job site. A wood pole scaffold shall not be erected beyond the reach of the local fire fighting apparatus.

(10) Diagonal bracing shall be provided to prevent the poles moving in a direction parallel with the wall or from buckling. Full diagonal face bracing shall be erected across the entire face of pole scaffolds in both directions. Brace splices shall be at the poles.

(11) The free ends of a pole scaffold shall be cross-braced.

(12) A wood pole scaffold shall not be erected beyond the reach of fire fighting equipment.

(13) Figure 1 reads as follows:

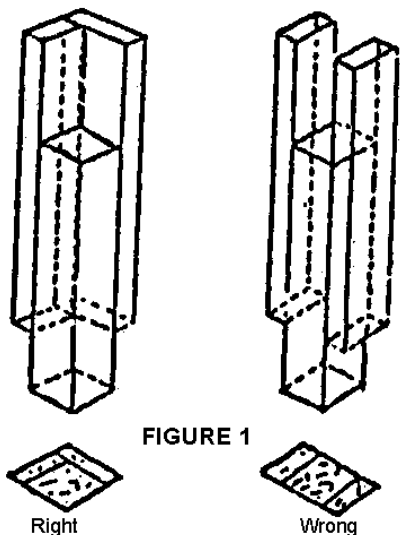

FIGURE 1

(14) Table 2 reads as follows:

TABLE 2 Minimum Nominal Size and Maximum Spacing of Members of Single Pole Scaffolds Light Duty		
	Maximum height of scaffold	
	20 ft.	60 ft.
Uniformly distributed load	Not to exceed 25 p.s.f.	
Poles or uprights	2 x 4 in.	4 x 4 in.
Pole spacing (longitudal)	6 ft. 0 in.	10 ft. 0 in
Maximum width of scaffold	5 ft. 0 in.	5 ft. 0 in.
Bearers of putlogs to 3 ft. 0 in. width	2 x 4 in.	2 x 4 in.
Bearers of putlogs to 5 ft. 0 in. width	2 x 6 in. or 3x4 in.	2 x 6 in. or 3 x 4 in. (rough)
Ledgers	1 x 4 in.	1 1/4 x 9 in. (rough)
Planking	2 x 10 in. (rough)	2 x 10 in.
Vertical spacing of horizontal members	7 ft. 0 in.	7 ft. 0 in.
Bracing, horizontal and diagonal	1 x 4 in.	1 x 4 in.
Tie-ins	1 x 4 in.	1 x 4 in.
Toeboards	4 in. high (min.)	4 in. high (min.)
Guardrail	2 x 4 in.	2 x 4 in.

All members except planking are used on edge.

(15) Table 3 reads as follows:

TABLE 3 Minimum Nominal Size and Maximum Spacing of Members of Single Pole Scaffolds Medium Duty	
Uniformly distributed load	Not to exceed 50 p.s.f.
Maximum height of scaffold	60 ft.
Poles or uprights	4 x 4 in.
Pole spacing (longitudal)	8 ft. 0 in.
Maximum width of scaffold	5 ft. 0 in.
Bearers or putlogs	2 x 10 in. or 3 x 4 in.
Spacing of bearers or putlogs	8 ft. 0 in.
Ledgers	2 x 10 in.
Vertical spacing of horizontal members	9 ft. 0 in.
Bracing, horizontal	1 x 6 in or 1 1/4 x 4 in.
Bracing, diagonal	1 x 4 in.
Tie-ins	1 x 4 in
Planking	2 x 9 in.
Toeboards	4 in. high (minimum)
Guardrail	2 x 4 in.

All members except planking are used on edge.

(16) Table 4 reads as follows:

TABLE 4 Minimum Nominal Size and Maximum Spacing of Members of Single Pole Scaffolds Heavy Duty	
Uniformly distributed load	Not to exceed 75 p.s.f.
Maximum height of scaffold	60 ft.
Poles or uprights	4 x4 in.
Pole spacing (longitudal)	6 ft. 0 in.
Maximum width of scaffold	5 ft. 0 in.
Bearers or putlogs	2 x 10 in. or 3 x 5 in. (rough)
Spacing of bearers or putlog	6 ft. 0 in.
Ledgers	2 x 10 in.
Vertical spacing of horizontal members	6 ft. 6 in.
Bracing, horizontal and diagonal	2 x 4 in.
Tie-ins	1 x 4 in.
Planking	2 x 10 in.
Toeboards	4 in. high (minimum)
Guardrail	2 x 4 in.

All members except planking are used on edge.

(17) Table 5 reads as follows:

TABLE 5 Minimum Nominal Size and Maximum Spacing of Members of Independent Pole Scaffolds Light Duty		
	Maximum height of scaffold	
	20 ft.	60 ft.
Uniformly distributed load	Not to exceed 25 p.s.f.	
Poles or uprights	2 x 4 in.	4 x 4 in.
Pole spacing (longitudinal)	6 ft. 0 in.	10 ft. 0 in.
Pole spacing (transverse)	6 ft. 0 in.	10 ft. 0 in.
Ledgers	1 1/4 x 4 in.	1 1/4 x 9 in.
Bearers to 3 ft. 0 in. span	2 x 4 in.	2 x 4 in.
Bearers to 10 ft. 0 in. span	2 x 6 in. or 3 x 4 in.	2 x 9 (rough) or 3 x 8 in.
Planking	1 1/4 x 9 in. (rough)	2 x 10 in.
Vertical spacing of horizontal members	7 ft. 0 in.	7 ft. 0 in.
Bracing horizontal and diagonal	1 x 4 in.	1 x 4 in.
Tie-ins	1 x 4 in.	1 x 4 in.
Toeboards	4 in. high	4 in. high (min.)
Guardrail	2 x 4 in.	2 x 4 in.

All members except planking are used on edge

(18) Table 6 reads as follows:

TABLE 6 Minimum Nominal Size and Maximum Spacing of Members of Independent Pole Scaffolds Medium Duty	
Uniformly distributed load	Not to exceed 50 p.s.f.
Maximum height of scaffold	60 ft.
Poles or uprights	4 x 4 in.
Pole spacing (longitudinal)	8 ft. 0 in.
Pole spacing (transverse)	8 ft. 0 in.
Ledgers	2 x 10 in.
Vertical spacing of horizontal members	6 ft. 0 in.
Spacing of bearers	8 ft. 0 in.
Bearers	2 x 10 in. (rough) or 2 x 10 in.
Bracing, horizontal	1 x 6 in. or 1 1/4 x 4 in.
Bracing, diagonal	1 x 4 in.
Tie-ins	1 x 4 in.
Planking	2 x 10 in.
Toeboards	4 in. high (min.)
Guardrail	2 x 4 in.

All members except planking are used on edge

(19) Table 7 reads as follows:

TABLE 7 Minimum Nominal Size and Maximum Spacing of Members of Independent Pole Scaffolds Heavy Duty	
Uniformly distributed load	Not to exceed 75 p.s.f.
Maximum height of scaffold	60 ft.
Poles or uprights	4 x 4 in.
Pole spacing (longitudinal)	6 ft. 0 in.
Pole spacing (transverse)	8 ft. 0 in.
Ledgers	2 x 10 in.
Vertical spacing of horizontal members	4 ft. 6 in.
Bearers	2 x 10 in. (rough)
Bracing, horizontal and diagonal	2 x 4 in.
Tie-ins	1 x 4 in.
Planking	2 x 10 in.
Toeboards	4 in. high (min.)
Guardrail	2 x 4 in.

All members except planking are used on edge

R 408.10522. Independent pole scaffold, specific.

Rule 522. (1) An independent pole scaffold shall be set as close to the wall of the building as possible.

(2) Cross bracing shall be provided between the inner and outer set of poles of an independent pole scaffold.

R 408.10523. Single pole scaffold, specific.

Rule 523. Single pole scaffolding shall:

- Have the inner end of the bearer rest in the wall of the building with at least a 4 inch bearing. Notching is prohibited.
- Have the inner end of the bearer, when used on frame buildings, rest on a block 12 inches long and not less than 2 inches by 6 inches nominal size. The block shall be notched the width of the bearer and not less than 2 inches deep. The bearer shall be nailed to both the block and the building.
- Have the inner end of the bearer, when it comes at a window opening, supporting by a plank of equal strength resting on the window sill and fastened to the building. The bearer shall be braced against displacement.
- Have a bearer reinforced with a 3/16 by 2 inch steel strip or its equivalent secured to its lower edge along its entire length.

R 408.10524. Suspension scaffolding.

Rule 524. (1) A suspension scaffold, including the supporting thrustout, shall be capable of sustaining a working load of 50 pounds per square foot with a designed safety factor of not less than 4.

(2) Wire ropes used on suspension scaffolding shall have a designed safety factor of not less than 6. Wire ropes fastened around a rod shall be equipped with a thimble.

(3) When "U" bolt clamps are installed, a minimum of 3 shall be used at each fastening with the "U" bolts installed on the dead end (see table 8). The clamps shall be retightened after loading.

(4) A thrustout for a suspension scaffold shall be not less than a 7 inch, 15.3 pound steel "I" beam which is not less than 15 feet long and which does not project more than 6 1/2 feet beyond the bearing point. It shall be set with the web vertical and spaced not more than 7 feet apart and shall project 1 foot beyond the outer edge of the suspension platform.

(5) The thrustout inner end shall be fastened to the frame of the building with bolts, anchor plates, lockwashers, and jam nuts and it shall be anchored against horizontal displacement or a thrustout may be counterbalanced if the counterweight is fastened to the thrustout. Sand bags or other loose material shall not be used. Where a counterweight is used, it shall be 3 times the supported weight and located on the inner end of the thrustout with the center of the counterweight mass not less than equal distance to the center of the weight of the load as measured from the fulcrum.

(6) A thrustout outer end shall be equipped with a stop-bolt to prevent the shackle slipping over the edge. A thrustout rigged over a parapet wall shall be supported by a wood block a minimum of 4 by 4 by 18 inches long nominal size at that point.

(7) A suspension platform shall be secured to prevent swinging away from the building. Rollers or fenders shall be provided to prevent striking the building and to facilitate raising and lowering.

(8) A bearer for a suspension scaffold shall be made of 4 by 6 inch timber set on edge or structural steel of equivalent strength. A bearer shall have sufficient length to hold the planks between the frame where a hoisting machine is used. Plank edges shall abut.

(9) A powered hoisting machine, where used, shall conform to R 408.10548. The running edge of the suspension wire rope shall be securely attached to the hoisting drum, and not less than 4 turns of rope shall remain on the drum at all times.

(10) Each scaffold shall be installed or relocated in accordance with designs and instructions of a registered professional mechanical or civil engineer, and such installation or relocation shall be supervised by a competent designated person.

(11) Table 8 reads as follows:

TABLE 8
APPLYING WIRE ROPE CLIPS
 Distance between clips should be equal to six rope diameters

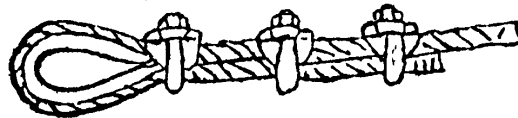

CORRECT METHOD:
 U-Bolts of Clips on short end of rope.

WIRE ROPE OR CABLE
NUMBER AND SPACING OF CLIPS FOR ROPES OF
VARIOUS SIZES

Diameter of rope (in.)	Number of clips	Center-to-center space between clips (in.)	Length of rope turned back exclusive of eye (in.)	Length of wrench (in.)
1/2	3	3	9	12
5/8	3	3 3/4	12	12
3/4	4	4 1/2	18	18
7/8	4	5 1/4	21	18
1	4	6	24	24
1 1/8	5	6 3/4	34	24
1 1/4	5	7 1/2	38	24
1 3/8	6	8 1/4	50	24
1 1/2	6	9	54	24
1 5/8	6	9 3/4	60	30
1 3/4	7	10 1/2	74	30
1 7/8	8	11 1/4	90	30
2	8	12	96	30
2 1/8	8	13	104	30
2 1/4	8	14	112	30

R 408.10525. Swinging scaffolds.

Rule 525. (1) A platform for a swing scaffold shall have a bar, strip, or other device attached to the platform outside the hanger to prevent the platform from slipping off the hanger. A platform shall be not less than 20 inches nor more than 36 inches wide.

(2) Where rope and blocks are used to support a swing scaffold, the scaffold shall comply with all of the following requirements:

- (a) Have hangers made of 3/4 inch round steel, or its equivalent: which are designed to have a flat bottom to hold a platform and which have arms to hold a standard barrier pursuant to R 408.1 051 3(2) and a loop to hold the hook on a block.
- (b) Have supporting ropes of 3/4 inch, first-quality manila, or its equivalent, which are used with not less than 1 6-inch single and 1 6-inch double block. When acid cleaning or sandblasting is done, not less than 5/16 inch wire rope shall be used.
- (c) Have all blocks fit the size of rope they carry.

(d) Have ropes made fast to the point of the hook on the hanger eye by a special hitch which cannot slip.

(3) The platform, rope, slings, and other supporting parts shall be inspected before each installation. Periodic inspections shall be made while the scaffold is in use.

(4) A hook with an eye or ring that is used to support the swing scaffold on the building shall be wrought iron or steel of a cross section not less than 5/8 by 2 inches, or equivalent, with the 5/8 inch measurement on the edge. Eaves or cornices shall be inspected for cracks, loose blocks, or other deterioration before setting the hooks. A hook shall have a safety line of 3/4 inch manila rope, or its equivalent, secured from an eye or ring to a structurally sound portion of the building to prevent slipping of the hook.

(5) Two or more scaffolds shall not be combined by bridging with planks or similar connecting links, unless the scaffolds are equipped with hoisting machines and the planking has the capability to pivot and remain secured to the unit.

(6) Occupancy on a swing scaffold shall be limited as follows:

(a) Maximum designed working load of 500 pounds, 2 employees.

(b) Maximum designed working load of 750 pounds, 3 employees.

(7) An employee using a swing scaffold shall use a safety belt tied to a lifeline by a lanyard not more than 48 inches long connected by an approved fall prevention device on the lifeline. The lifeline shall extend to the ground.

(8) In lieu of providing a lifeline, an employee may attach a safety belt and lanyard to the scaffold, if a separate fall prevention device is installed at each support point, using safety lines equivalent to the support ropes, and if the device is connected to the scaffold with a line which will allow a drop of not more than 12 inches.

(9) Swing scaffolds shall be equipped with rollers or fenders as prescribed in R 408.10524(7).

(10) When not in use, a swing scaffold shall be secured to the building or ground, and all tools and materials shall be removed.

(11) When a hoisting machine is used with a swing scaffold, it shall be as prescribed in R 408.10548 and R 408.10549.

R 408.10526. Outrigger's scaffolds.

Rule 526. (1) A thrustout for an outrigger scaffold shall be of timber 3 by 10 inches nominal, set on edge, or of structural steel of equal strength set with the web vertical. A thrustout shall extend outside the building not more than 6 feet, shall be spaced not more than 6 feet centers, and shall be fastened to prevent twisting or other movement. A thrustout shall be braced diagonally from the outside end to the building. The brace shall be not less than 25% longer than the extended length of the thrustout. The inboard end of outrigger beams, measured from the fulcrum point to the extreme point of support, shall be not less than 1 1/2 times the outboard end in length.

(2) A suspended platform shall be formed by use of 2 by 6 inch nominal vertical hangers and 2 by 6 inch nominal bearers. A vertical hanger shall be braced to prevent side sway and be not more than 10 feet long. Additional support blocks shall be nailed to the vertical hangers above the thrustouts and below the bearers. The inboard ends of outrigger beams shall be securely supported, either by means of struts bearing against sills in contact with the overhead beams or ceiling, or by means of tension members secured to the floor joist underfoot, or by both if necessary. The inboard ends of outrigger beams shall be secured against tipping, and the entire supporting structure shall be

securely braced in both directions to prevent any horizontal movement.

(3) Planking for the platform shall abut edges tightly from end of thrustout to building or from vertical hanger to vertical hanger, and shall be as prescribed in R 408.10512.

(4) A standard barrier and toeboard shall be installed as prescribed in R 408.10231 and R 408.10233 of general industry safety standard Part 2. "Floor and Wall Openings, Stairways and Skylights."

(5) A horse scaffold shall not be used with an outrigger's scaffold.

(6) Outrigger scaffolds designed by a registered professional mechanical or civil engineer shall be constructed and erected in accordance with such design. A copy of the detailed drawings and specifications, showing the sizes and spacing of members, shall be kept on the job. Where additional working levels are required to be supported by the outrigger method, the plans and specifications of the outrigger and scaffolding structure shall be designed by a registered professional mechanical or civil engineer.

R 408.10527. Horse scaffolds.

Rule 527. (1) A horse scaffold shall be built pursuant to table 9 of straight-grained lumber and braced to resist side thrusts.

(2) A horse higher or longer than 4 feet shall have the cross section of each member increased to the next nominal size in width.

(3) Nailing of extension pieces to the legs is prohibited.

(4) Legs shall be set on concrete, another hard surface, or base plates as prescribed in R 408.10513(7).

(5) Horses shall be spaced not more than 6 feet apart on bearer centers.

(6) When tiering, a horse scaffold shall be placed above the one below and the legs held in place by cleats nailed to the planking. A horse scaffold shall not be tiered more than 2 high or 10 feet high.

(7) Table 9 reads as follows:

TABLE 9 Nominal size material for a 4 foot long x 4 foot high horse.	
Bearers	2 x 6 inches
Legs	2 x 4 inches
Brace between legs	1 x 6 inches
Gusset brace at top of leg	1 x 8 inches
Half diagonal brace	1 x 6 inches

R 408.10528. Ladder jack scaffolds.

Rule 528. (1) A ladder jack scaffold shall be used on a Type 1, sometimes-called heavy duty, manufactured ladder only, and at heights not more than 20 feet from the ground or floor level.

(2) The span of a wood plank shall be not more than 8 feet between ladder jacks, and the planking shall be as prescribed in R 408.10512.

(3) The span of a pick shall not exceed 24 feet.

(4) A ladder jack scaffold shall be limited to 2 employees at any 1 time, except if 3 ladders support the plank 3 employees may occupy the plank. Not more than 2 employees shall occupy any given 8 feet of plank at any 1 time.

(5) A ladder used with a ladder jack shall be equipped with nonslip feet pursuant to R 108.10447 of the general industry safety standard, Part 4. "Portable Ladders," R 408.10401 to R 408.10456.

(6) A ladder jack shall be made of metal with a designed strength to sustain the load as prescribed in subrule (1) of R 408.10513. A ladder jack shall be designed to bear on the side rails in addition to the rungs, or if bearing on the rungs only, the bearing surface shall be not less than 10 lineal inches on each rung.

R 408.10529. Boatswain's chair.

Rule 529. (1) The wood seat of a boatswain's chair shall be not less than nominal 12 by 24 inches by 1 inch thick with the underside reinforced by cleats fastened to prevent splitting.

(2) Two 5/8 inch fiber, or equivalent, rope slings shall be reeved through 4 set holes so as to cross each other on the underside. Where an employee is using a heat-or spark-producing process such as gas or arc welding or cutting, 3/8 inch wire rope shall be used in place of the fiber rope.

(3) The employee shall use a safety belt and lifeline. The lifeline shall be securely attached to substantial members of the structure, not scaffold, or to securely rigged lines, which will safely suspend the worker in case of a fall.

(4) The tackle shall consist of bearing or bushed blocks and 5/8 inch manila rope, or its equivalent. A roof iron, hook, or other object to which the tackle is anchored shall be secured to prevent dislodgment. Tie backs shall be installed at right angles to the face of the building and secured to the roof hooks and the building.

R 408.10530. Bricklayer's square scaffold.

Rule 530. (1) The squares of a bricklayer's square scaffold shall be not more than 5 feet wide by 5 feet high and set not more than 5 feet apart for medium duty and not more than 8 feet apart for light duty. The bearers and legs shall be made of 2 by 6 inch material, the corner braces of 1 by 6 material and the diagonal braces of 1 by 8 inch material.

(2) Additional 1 by 8 inch bracing shall extend from the bottom of each square to the top of the next square on the front and rear of the scaffold.

(3) Platform planks shall be not less than 2 by 10 inches with the ends overlapping the bearers of the squares. Each plank shall be supported by not less than 3 squares.

(4) If tiered, the tiers shall not exceed 3 in height with 1 square resting directly above another square. The upper tiers shall rest on continuous rows of planking with the square secured to the planks.

R 408.10531. Carpenter's bracket scaffold.

Rule 531. (1) The supporting brackets of a carpenter's bracket scaffold shall be a triangular frame of not less than 2 by 3 inch material fitted and secured together or of metal of equivalent strength, and of such size to support not less than two, 2 by 10 inch planks.

(2) The supporting brackets shall be fastened to the structure by 1 of the following:

- (a) If made of wood, the corners shall be gusseted in a manner to prevent the joints pulling apart.
- (b) Through bolts not less than 5/8 inch in diameter and long enough to project 3/4 inch beyond the nut when in place.
- (c) A metal stud attachment device.
- (d) Welding to a metal tank.
- (e) Hooking over a secured supporting member capable of sustaining the imposed load.

(3) The supporting brackets shall be not more than 10 feet apart to support 1 employee and not more than 75 pounds of material, or 6 feet apart to support 2 employees and not more than 75 pounds of material.

R 408.10532. Working surfaces; steep slopes.

Rule 532. (1) An employee working on a roof where the working area is more than 20 feet above the ground, the pitch is more than 3 inches in 12 inches, and there is no roof parapet, shall be provided and use a roofing bracket scaffold or crawling board.

(2) An employee using a roofing bracket scaffold or crawling board shall use a safety belt and lifeline or a catch platform shall be provided. The catch platform shall extend 2 feet beyond the projection of the eaves or structure, whichever is farther away, and shall be equipped with a standard barrier and toeboard as prescribed in R 408.10231 and R 408.10233 of general industry safety standard Part 2. "Floor and Wall Openings, Stairways, and Skylights."

R 408.10533. Roofing brackets and crawling boards.

Rule 533. (1) A roofing bracket shall fit the pitch the roof so as to maintain the working plank level.

(2) A roofing bracket shall be secured by nails in addition to the bracket's pointed metal projection, except where a 3/4 inch first grade manila rope, or equivalent, is used as a support.

(3) A crawling board not less than 1 by 10 inches shall extend from the roof eave to the ridge. Cleats shall be 1 by 1 1/2 inches and equal in length to the width of the crawling board. The cleats shall be secured to the crawling board by nails driven through and clinched on the underside. Space between cleats shall not exceed 24 inches.

(4) A crawling board shall be secured to a roof by ridge hooks or other equivalent means.

R 408.10534. Needle beam scaffold.

Rule 534. (1) Wood needle beams shall be not less than 4 by 6 inches with the greater dimension set vertically or equivalent structural steel may be used.

(2) The span between needle beams shall be not more than 8 feet when using 2 inch scaffolding planks.

(3) Rope supports shall be 1 inch diameter first grade manila rope, or equivalent material, and spaced not more than 10 feet apart. The rope shall be attached to the needle beams by a scaffold hitch or an eye splice. The loose end of the rope shall be tied by a bowline knot or a round turn and half hitch. The scaffold hitch shall be arranged in a manner so as to prevent the needle beam from rolling or otherwise becoming displaced.

(4) Scaffold planks shall be secured against displacement.

(5) Tools, bolts, and nuts or a needle beam scaffold shall be secured in containers.

(6) A needle beam scaffold shall be suspended from thrustouts prescribed in rule 524 or from permanent structural members if they have a safety factor of not less than 4 times the maximum intended load.

R 408.10535. Window jack scaffold.

Rule 535. (1) A window jack scaffold shall be used as a work platform for not more than 1 employee and only for the purpose of working at the window opening through which the jack is placed.

(2) A window jack scaffold shall consist of a plank secured to the structure with braces running from a point not more than 4 inches from the end of the plank to the structure at an angle of not less than 45 degrees to the horizontal.

(3) A window jack shall not be used to support a plank running from 1 window jack to another.

(4) Where the prescribed standard barrier cannot be used, the employee shall use safety harness and a lifeline secured to the structure.

MANUFACTURED SCAFFOLDING

R 408.10541. General.

Rule 541. (1) Manufactured scaffolding shall be erected and used as specified by the manufacturer's instructions.

(2) Manufactured scaffolding shall be constructed, installed and maintained as prescribed in rules 511, 512 and 513.

(3) Manufactured scaffolding shall be erected by a competent and experienced employee.

(4) Stationary manufactured scaffolding shall be tied to and braced against a building at intervals not to exceed 30 feet horizontally and 26 feet vertically or otherwise guyed.

(5) Adjusting screws on stationary manufactured scaffolding shall have an adjustment of not more than 18 inches from baseplate to bottom of frame with a minimum of 6 inches retained within the frame.

(6) Before a metal scaffold is erected near an exposed powerline, the utility or property owner shall be consulted. A power line or electrical apparatus shall be considered energized unless the property owner or utility indicates it is deenergized and the line or apparatus is visibly grounded. Where deenergizing is impracticable, the following minimum clearances shall be maintained:

Voltage	Clearance
To 50 kV	10 feet
Over 50 kV	10 feet + .4 inch per kV

R 408.10542. Tube and coupler-type scaffolding.

Rule 542. (1) A light-duty tube and coupler scaffold shall have all posts, bearers, ledgers, and braces of not less than 2 inch nominal O.D. steel tubing or equivalent with the posts spaced not more than 6 feet apart by 10 feet along the length of the scaffold. Other structural members shall be capable of carrying the intended load. The scaffold shall be limited to those heights and working levels prescribed in table 10.

(2) A medium-duty tube and coupler scaffold shall have all posts, ledgers and braces of not less than nominal 2 inch O.D. steel tubing or equivalent with the posts spaced not more than 6 feet apart by 8 feet along the length of the scaffold. Bearers shall be nominal 2 1/2 inch O.D. steel tubing of equivalent, except that 2 inch O.D. tubing may be used if the posts are spaced not more than 5 feet apart by 8 feet along the length of the scaffold. Other structural members shall be capable of carrying the intended load. The scaffold shall be limited to those heights and working levels prescribed in table 11.

(3) A heavy-duty tube and coupler scaffold shall have posts, ledgers and braces of not less than nominal 2 inch O.D. steel tubing or equivalent with the posts spaced not more than 6 feet apart by 6 1/2 feet along the length of the scaffold. Bearers shall be of not less than nominal 2 1/2 inch O.D. steel tubing or equivalent. Other structural members shall be capable of carrying the intended load. The scaffold shall be limited to those heights and working levels prescribed in table 12.

(4) A scaffold to be erected at a height greater than those prescribed in tables 10, 11, or 12 shall be designed by an engineer knowledgeable in scaffolding and a copy of the blue print shall be maintained at the job site.

(5) Tube and coupler type scaffolding shall comply with all of the following:

- (a)** Have ledgers erected along the length of the scaffold which are located on both inside and outside posts at each bearer level. Ledgers shall be interlocked to form continuous lengths and coupled to each post. The bottom ledgers shall be located as close to the base as possible. Ledgers shall be placed not more than 6 feet 6 inches on centers, vertically.
- (b)** Have bearers installed transversely between posts which are coupled to the posts and bearing on the ledger coupler. A bearer shall be not less than 4 inches nor more than 12 inches longer than the post spacing or ledger spacing. A bearer may be cantilevered for use with brackets to carry not more than 2 planks.
- (c)** Be cross braced across the width of the scaffold from the inner to outer ledgers at not less than every third set of posts horizontally and every fourth runner vertically. The bracing shall extend diagonally from the inner and outer ledgers upward to the next outer and inner ledgers.
- (d)** Have longitudinal bracing installed at approximately a 45 degree angle from the base of the first outer post toward the top of the scaffold. Where possible, bracing shall be repeated every fifth post. In a similar manner, longitudinal bracing shall also be installed from the last post extending back and upward toward the first post. Where conditions preclude the attachment of this bracing to the posts, it may be attached to the ledgers.

(6) Table 10 reads as follows:

Uniformly distributed loads	Not to exceed 25 p.s.f	
Post spacing (longitudinal)	10 ft. 0 in.	
Post spacing (transverse)	6 ft. 0 in.	
Working levels	Additional planked levels	Maximum height
1	8	125 ft.
2	4	125 ft.
3	0	91 ft. 0 in.

(7) Table 11 reads as follows:

Uniformly distributed load	Not to exceed 50 p.s.f	
Post spacing (longitudinal)	8 ft. 0 in.	
Post spacing (transverse)	6 ft. 0 in.	
Working levels	Additional planked levels	Maximum height
1	6	125 ft.
2	0	78 ft. 0 in.

(8) Table 12 reads as follows:

TABLE 12 Tube and Coupler Scaffolds Heavy Duty		
Uniformly distributed load	Not to exceed 75 p.s.f	
Post spacing (longitudinal)	6 ft. 6 in.	
Post spacing (transverse)	6 ft. 0 in.	
Working levels	Additional planked levels	Maximum height
1	6	125 ft.

R 408.10543. Welded frame type scaffolds.

Rule 543. (1) Welded frame type scaffolds shall:

- Be cross braced to secure vertical frames together laterally and have such length as to automatically insure the erected scaffold will be square, plumb, and rigid.
- Have the frames and panels secured by coupling pins to provide vertical alignment and prevent uplift.
- Have the panels or frames spaced in a manner to support the intended load.
- Be secured to the building or structure at intervals of not more than 30 feet horizontally and 26 feet vertically.
- Have the planking span limited to table 1 of the rule 512(8).

(2) Where welded frame type scaffold is erected at a height of more than 125 feet, it shall be designed by an engineer knowledgeable in scaffolding and a copy of the blue print shall be maintained at the job site.

(3) The frame and accessories of a welded frame type scaffold shall be inspected for defects before each job use and after misuse. Defective parts shall be repaired or replaced. Repairs and replacements shall have the capability of supporting the intended load.

R 408.10544. Mobile scaffolds.

Rule 544. (1) A mobile scaffold shall be constructed as prescribed in rules 542 or 543 and shall be limited to a height of 50 feet unless designed and erected by an engineer knowledgeable in scaffolding.

(2) A mobile scaffold shall:

- Not exceed a height of 4 times the minimum base dimension, or shall be guyed every 20 feet of height to prevent movement. Outriggers, when used, may be considered as part of the base dimension.
- Have a landing platform at intervals of not more than 30 feet.
- Have the wheels locked when in use and attached by pins or bolts, or other equivalent means, to the frame or adjusting screw.
- Have a limit adjustment of screw jack to not more than 12 inches from top of castor bearing plate to bottom of frame. The castor stem shall fit the socket in the frame and extend inside not less than 6 inches.
- Have all scaffold castors provided with a positive wheel, a swivel lock, or both, to prevent movement.
- Have adequate rigid diagonal bracing to vertical members provided.
- Have exposed surfaces free from sharp edges, burrs, and other hazards.
- Have the width of a working platform at any level not less than 20 inches and secured in place.

(i) Have the designed load of all mobile scaffolds calculated on the basis of: Light - Designed and constructed to carry a working load of 25 pounds per square foot. Medium - Designed and constructed to carry a working load of 50 pounds per square foot. Heavy - Designed and constructed to carry a working load of 75 pounds per square foot.

(j) Have the work level platform of scaffolds, sometimes called towers, of wood, aluminum, or plywood planking, steel, or expanded metal for the full width of the scaffold, except for necessary openings. Work platforms shall be secured in place.

(3) A sectional folding stairway scaffold shall:

- Be designed as medium duty, except for high clearance. A sectional folding stairway scaffold with a high clearance base shall be designated as a light duty scaffold.
- Have an integral stairway and work platform incorporated into the structure.
- Have the end frames designed so that the horizontal bearers provide supports for multiple planking levels.
- Be not more than 4 1/2 feet wide by 6 feet in length.

(4) A sectional folding ladder scaffold shall:

- Be designed as a light duty scaffold, including special base open end sections which are designed for high clearance. For certain special applications, the 6 foot in length folding ladder scaffolds, except for special high clearance base sections, shall be designed for use as medium duty scaffolds.
- Have width of not more than 4 1/2 feet.
- Have a length of not more than 6 feet 6 inches for a 6 foot long unit, 8 feet 6 inches for an 8 foot unit, or 10 feet 6 inches for a 10 foot long unit.
- Have the end frames designed so that the horizontal bearers provide supports for multiple planking levels.
- Have an integral set of pivoting and hinged folding diagonal and horizontal braces and a detachable work platform incorporated into the structure.

R 408.10545. Wire rope scaffolding.

Rule 545. (1) Wire rope used as a supporting means for a plank shall have a designed safety factor of not less than 6 with the load figure including the total weight of men, materials and scaffold.

(2) A plank used on a wire rope scaffold shall be as prescribed in rule 512. A lifeline prescribed in subrule (7) of rule 525 shall be used.

(3) A plank used on a wire rope scaffold shall be attached to the wire rope in a manner which will not allow the plank to disengage such rope and shall facilitate moving the plank along the wire rope.

(4) Wire rope shall be used and maintained as prescribed in rule 571.

R 408.10546. Powered and manual mobile elevating platforms.

Rule 546. (a) Powered and manual mobile elevating platforms shall be operated as prescribed in general industry safety standard, Part 58. "Aerial Work Platforms," R 408.15801 to R 408.15842.

(b) Powered industrial trucks shall be operated as prescribed in general industry safety standard, Part 21. "Powered Industrial Trucks," R 408.12101 to R 408.12193.

R 408.10547. Rescinded.

R 408.10548. Powered hoisting machine.

Rule 548. (1) A powered hoisting machine shall be inspected not less than once a month when in service and not put into service unless free of hazards.

(2) A powered hoisting machine manufactured after the effective date of this part shall carry a label of an approved nationally recognized testing laboratory such as underwriters laboratories or factory mutual engineering corporation that the machine is approved for the use on a suspension scaffold, swinging scaffold, or powered mobile elevating platform.

R 408.10549. Manual powered hoisting devices.

Rule 549. A manually powered hoisting device shall be equipped with a positive locking device.

R 408.10550. Hydraulic and pneumatic systems.

Rule 550. (1) Rigid or flexible piping and the component parts or a hydraulic or pneumatic hoisting machine system shall have a safety factor of not less than 4.

(2) When a hydraulic or pneumatic system is bled, the platform supported by this system shall be in the lowered position or blocked in such a manner that the safety of the employee is assured.

(3) A leak in a hydraulic or pneumatic system shall be repaired before the unit is used.

(4) A reverse check valve or equivalent means shall be installed in the hydraulic cylinder to prevent uncontrolled fall of the work platform in case of system failure.

POWERED PLATFORMS**R 408.10561. Construction and modification; requirements for buildings utilizing working platforms for maintenance; tie-in guides.**

Rule 561. (1) A powered platform installed, or that part of a powered platform modified, after August 27, 1971, shall be in compliance with the design and manufacturing requirements prescribed in ASME standard A120.1, 1970 edition, 'Safety requirements for powered platforms for exterior building maintenance, which is adopted in R 408.10509 by reference, and as further prescribed in the rules of this part.

(2) The following requirements apply to affected parts of buildings that utilize working platforms for building maintenance:

- (a) Structural supports, tie-downs, tie-in guides, anchoring devices, and any affected parts of the building that are included in the installation shall be designed by, or under the direction of, a registered professional engineer who is experienced in such design.
- (b) Exterior installations shall be capable of withstanding prevailing climatic conditions.
- (c) The building installation shall provide safe access to, and egress from, the equipment and shall provide sufficient space to conduct necessary maintenance of the equipment.
- (d) The affected parts of the building shall have the capability of sustaining all of the loads imposed by the equipment.
- (e) The affected parts of the building shall be designed to allow the equipment to be used without exposing employees to a hazardous condition.

(3) The exterior of each building shall be provided with tie-in guides unless the conditions specified in either of the following provisions are met:

- (a) Tie-in guides required pursuant to this rule may be eliminated for not more than 75 feet (22.9 m) of the uppermost elevation of the building if angulated roping is employed, if the use of tie-in guides is not feasible due to the exterior building design, and if an angulation force of not less than 10 pounds (44.4 n) is maintained under all conditions of loading.
- (b) Tie-in guides may be eliminated if 1 of the specified guide systems is provided as specified in R 408.10562 and R 408.10563.

R 408.10562. Intermittent stabilization systems.

Rule 562. (1) An intermittent stabilization system shall keep equipment in continuous contact with the building facade and shall prevent sudden horizontal movement of the platform. The system may be used together with continuous positive building guide systems that use tie-in guides on the same building if the requirements of each system are met.

(2) The maximum vertical interval between building anchors shall be 3 floors or 50 feet (15.3 m), whichever is less.

(3) Building anchors shall be located vertically so that attachments of the stabilizer ties will not cause the platform suspension ropes to angulate the platform horizontally across the face of the building. The anchors shall be positioned horizontally on the building face so as to be symmetrical about the platform suspension ropes.

(4) Building anchors shall be visible to employees and shall allow a stabilizer tie attachment for each of the platform suspension ropes at each vertical interval. If more than 2 suspension ropes are used on a platform, only the 2 building-side suspension ropes at the platform ends shall require a stabilizer attachment.

(5) Building anchors that extend beyond the face of the building shall be free of sharp edges or points. Where cables, suspension wire ropes, and lifelines may be in contact with the building face, external building anchors shall not interfere with their handling or operation.

(6) The intermittent stabilization system building anchors and components shall be capable of sustaining, without failure, not less than 4 times the maximum anticipated load applied or transmitted to the components and anchors. If 2 anchors share the wind load, the minimum design wind load for each anchor shall be 300 pounds (1334 n).

(7) The building anchors and stabilizer ties shall be capable of sustaining anticipated horizontal and vertical loads from winds specified for roof storage design which may act on the platform and wire ropes if the platform is stranded on a building face. If the building anchors have different spacing than the suspension wire rope or if the building requires different suspension spacings on 1 platform, 1 building anchor and stabilizer tie shall be capable of sustaining the wind loads.

(8) A powered platform shall be suspended by 2 or more cables. Where 2 cables are used, each employee on the work platform shall use a safety harness and lanyard that is attached to an individual lifeline. The lifeline shall be secured to the building structure and shall be independent of any cable and structures that support the powered platform.

(9) When normal voice communication cannot be understood, a powered platform shall be equipped with a 2-way voice communication system between the operator and persons who are stationed at a supervised location in the vicinity or within the building being serviced. The communication system shall be operative and shall be tended at all times.

(10) Where thrustouts are used in place of a roof car, they shall be anchored to the building structure with fasteners that are capable of sustaining the imposed load.

R 408.10563. Button guide stabilization systems.

Rule 563. (1) Guide buttons shall be coordinated with platform-mounted equipment.

(2) Guide buttons shall be located horizontally on the building face to allow engagement of each of the guide tracks mounted on the platform.

(3) Guide buttons shall be located in vertical rows on the building face for proper engagement of the guide tracks mounted on the platform.

(4) Two guide buttons shall engage each guide track at all times, except for the initial engagement.

(5) Guide buttons that extend beyond the face of the building shall be free of sharp edges or points. Where cables, ropes, and lifelines may be in contact with the building face, guide buttons shall not interfere with their handling or operation.

(6) Guide buttons, connections, and seals shall be capable of sustaining, without damage, at least the weight of the platform or the guide tracks or guide track connectors shall have provisions to prevent the platform and its attachments from transmitting the weight of the platform to the guide buttons, connections, and seals. In either case, the minimum design load shall be 300 pounds (1334 n) per building anchor.

R.408.10564. Design of installation.

Rule 564. (1) The requirements of this rule apply to equipment that is part of a powered platform installation, such as any of the following:

- (a) Platforms.
- (b) Stabilizing components.
- (c) Carriages.
- (d) Outriggers.
- (e) Hoisting machines.
- (f) Wire ropes.
- (g) Electrical components.

(2) Equipment installations shall be designed by, or under the direction of, a registered professional engineer who is experienced in such design.

(3) The design shall provide for a minimum live load of 250 pounds (113.6 kg) for each occupant of a suspended or supported platform.

(4) Equipment that is exposed to wind when not in service shall be designed to withstand forces generated by winds that have a velocity of 100 miles per hour (44.7 m/s) or more at 30 feet (9.2 m) above grade.

(5) Equipment that is exposed to wind when in service shall be designed to withstand forces generated by winds that have a velocity of 50 miles per hour (22.4 m/s) or more for all elevations.

(6) Bolted connections shall be self-locking or shall otherwise be secured to prevent the loss of the connections by vibration.

R 408.10565. Roof cars; carriages; suspension methods.

Rule 565. (1) A roof car shall be used when it is necessary to move a working platform horizontally to a work or storage position.

(2) Movements of a roof car shall be restricted to a designated path of travel. Mechanical stops shall be provided and shall prevent the roof car from traversing outside the intended path of travel. The stops shall be capable of withstanding a force equal to 100% of the inertial effect of the roof car under power and shall be designed to prevent a crushing or shearing hazard.

(3) Elevated building maintenance equipment shall be suspended by a roof car, carriage, outrigger, davits, or an equivalent method.

(4) Carriages or roof cars shall be in compliance with all of the following provisions:

- (a) The horizontal movement of a carriage shall be controlled to ensure its safe movement and allow accurate positioning of the platform for vertical travel or storage.
- (b) Powered carriages shall not exceed a traversing speed of 50 feet per minute (0.3 m/s).
- (c) The initiation of a traversing movement for a manually propelled carriage on a smooth level surface shall not require a person to exert a horizontal force of more than 40 pounds (444.8 n).
- (d) Structural stops and curbs shall be provided to prevent the traversing of the carriage beyond its designed limits of travel.
- (e) Traversing controls for a powered carriage shall be of a continuous pressure weatherproof type. Multiple controls, when provided, shall be arranged to permit operation from only 1 control station at a time. An emergency stop device shall be provided on each end of a powered carriage for interrupting power to the carriage drive motors.
- (f) The operating control or controls shall be connected so that, in the case of suspended equipment, traversing of a carriage is not possible until the suspended portion of the equipment is located at its uppermost designed position for traversing and is free of contact with the face of the building or building guides. All protective devices and interlocks shall be in the proper position to allow traversing of the carriage.
- (g) Stability for underfoot supported carriages shall be obtained by gravity, by an attachment to a structural support, or by a combination of gravity and a structural support. The use of flowing counterweights to achieve stability is prohibited.
- (h) The stability factor against overturning shall not be less than 5 for horizontal traversing of the carriage, including the effects of impact and wind.
- (i) The carriages and their anchorages shall be capable of resisting accidental overtensioning of the wire ropes that suspend the working platform, and this calculated value shall include the effect of 1-112 times the stall capacity of the hoist motor. The forces that result from the stall load of the hoist and 112 of the wind load shall not cause damage to any part of the installation.
- (j) Roof carriages that rely on having tie-down devices secured to the building to develop the required stability against overturning shall be provided with an interlock that will prevent vertical platform movement unless the tie-down is engaged.
- (k) An automatically applied braking or locking system, or an equivalent, shall be provided that will prevent the unintentional traversing of power-traversed or power-assisted carriages.
- (l) A manual or automatic braking or locking system, or an equivalent, shall be provided that will prevent the unintentional traversing of manually propelled carriages.
- (m) A means to lock out the power supply for the carriage shall be provided.

- (n) Safe access to, and egress from, the carriage shall be provided from a safe surface. If the carriage traverses an elevated area, any operating area on the carriage shall be protected by a guardrail system in compliance with general industry safety standard Part 2. "Floor and Wall Openings, Stairways, and Skylights," R 408.10201 to R 408.10241. Any access gate shall be self-closing and self-latching or shall be provided with an interlock.
- (o) Each carriage work station position shall be identified by location markings or position indicators, or both.
- (p) A motor shall stall if the load on the hoist motor is at any time more than 3 times that necessary for lifting the working platform with its rated load.

R 408.10566. Outriggers

Rule 566. (1) Outriggers may be used as a method of suspension for ground-rigged working platforms where the point of suspension is not more than 300 feet (91.5 m) above a safe surface. A tie-in guide system or systems shall be provided and shall be in compliance with the requirements of R 408.10561 and R 408.10562.

(2) Outriggers shall be used only with self-powered, ground-rigged working platforms.

(3) Each outrigger shall be secured with a tie-down to a verified anchorage on the building during the entire period of its use. The anchorage shall be designed to have a stability factor of not less than 4 against overturning or upsetting the outrigger.

(4) Access to and egress from the working platform shall be from and to a safe surface below the point of suspension.

(5) Each portable outrigger shall be designed for lateral stability to prevent rollover if lateral load is accidentally applied to the outrigger. The accidental lateral load to be considered in this design system shall be not less than 70% of the rated load of the hoist.

(6) Each portable outrigger shall be designed to support a load of not less than 4 times the rated load of the hoist.

(7) Each portable outrigger shall be located so that the suspension wire ropes for 2-point suspended working platforms are hung parallel.

(8) A portable outrigger shall be tied back to a verified anchor on the building with a rope that is equivalent in strength to the suspension rope.

(9) The tie-back rope shall be installed parallel to the centerline of the outrigger.

R 408.10567. Davits.

Rule 567. (1) Every davit installation, whether fixed or portable or rotatable or nonrotatable, shall be designed and installed to insure that it has a stability factor against overturning of not less than 4.

(2) Both of the following requirements apply to roof-rigged davit systems:

- (a) Access to and egress from the working platform shall be from a safe surface. Access or egress shall not require persons to climb over a building's parapet or guard railing.
- (b) The working platform shall be provided with wheels, casters, or a carriage for traversing horizontally.

(3) Both of the following requirements apply to ground-rigged davit systems:

- (a) The point of suspension shall not be more than 300 feet (91.5 m) above a safe surface. A guide system or systems shall be provided and shall be in compliance with the requirements of R 408.10561 and R 408.10562.
- (b) Access and egress to and from the working platform shall only be from a safe surface that is below the point of suspension.
 - (4)** A rotating davit shall not require a horizontal force of more than 40 pounds (177.9 n) per person to initiate a rotating movement.
 - (5)** All of the following requirements shall apply to portable davits:
 - (a) A davit or part of a davit that weighs more than 80 pounds (36 kg) shall be provided with a means for its transport, which shall keep the center of gravity of the davit at or below 36 inches (914 mm) above the safe surface during transport.
 - (b) A davit shall be provided with a pivoting socket or with a base that will allow the insertion or removal of a davit at a position of not more than 35 degrees above the horizontal, with the complete davit inboard of the building face being serviced.
 - (c) Means shall be provided to lock the davit to its socket or base before it is used to suspend the platform.

R 408.10568. Perimeter guarding; equipment stops; maintenance access; elevated track system walkway and guardrail system; platform access and egress safety; certain anchors, fasteners, and structures to be corrosion resistant; cable installation; emergency action plan; repairs or major maintenance to parts of building providing primary support.

Rule 568. (1) Employees who work on roofs while performing building maintenance shall be protected by a perimeter guarding system that meets the requirements of general industry safety standard, Part 2. "Floor and Wall Openings, Stairways, and Skylights," R 408.10201 to R 408.10241.

(2) The perimeter guard shall not be more than 6 inches (152 mm) inboard of the inside face of a barrier, for example, the parapet wall, or roof edge curb of the building being serviced; however, the perimeter guard location shall not be set back more than 18 inches (457 mm) from the exterior building face.

(3) Operational areas for trackless type equipment shall be provided with structural stops, such as curbs, to prevent equipment from traveling outside its intended travel areas and to prevent a crushing or shearing hazard.

(4) Means shall be provided to traverse all carriages and their suspended equipment to a safe area for maintenance and storage. Maintenance shall be performed on equipment in a stored position when possible.

(5) An elevated track system which is located 4 feet (1.2 m) or more above a safe surface and which is traversed by carriage supported equipment shall be provided with a walkway and guardrail system or else the working platform shall be capable of being lowered, as part of its normal operation, to the lower safe surface for access and egress of the personnel and shall be provided with a safe means of access and egress to the lower safe surface.

(6) Imbedded tie-down anchors, fasteners, and affected structures shall be resistant to corrosion.

(7) Hanging lifelines and all cables that are not in tension shall be stabilized at 200-foot (61 m) intervals of vertical travel of the working platform beyond an initial 200-foot (61 m) distance.

(8) Hanging cables, other than suspended wire ropes, that are in constant tension shall be stabilized when the vertical travel is more than an initial 600-foot (183 m) distance. Beyond the initial 600 feet, cables shall be stabilized at intervals of 600 feet (183 m) or less.

(9) A written emergency action plan shall be developed and implemented for each kind of working platform operation. This plan shall explain the emergency procedures that are to be followed in the event of a power failure, equipment failure, or other emergencies which may be encountered. The plan shall include building emergency escape routes, procedures, and alarm systems to be used by each employee before operating a platform. Upon initial assignment and when the plan is changed, the employer shall review, with each employee, those parts of the plan that the employee is required to know in the event of an emergency.

(10) Repairs or major maintenance of those building portions that provide primary support for the suspended equipment shall not affect the capability of the building to be in compliance with the requirements of these rules.

R 408.10569. Electrical requirements.

Rule 569. The following electrical requirements apply to buildings that utilize working platforms for building maintenance:

- (a) General building electrical installations shall be in compliance with the provisions of general industry safety standard Part 39. Design Safety Standards for Electrical Systems.
- (b) Building electrical wiring shall be of such capacity that when a full load is applied to the equipment power circuit not more than a 5% drop from building service-vault voltage shall occur at any power circuit outlet that is used by equipment regulated by these rules.
- (c) The equipment power circuit shall be an independent electrical circuit that shall remain separate from all other equipment within or on the building, other than power circuits that are used for hand tools which will be used in conjunction with the equipment. If the building has an emergency power system, the equipment power circuit may also be connected to this system.
- (d) The power circuit shall be provided with a disconnect switch that can be locked in the "off" or "on" position. The switch shall be located to allow the operators of the equipment access to the switch.
- (e) The disconnect switch for the power circuit shall be locked in the "on" position when the equipment is in use.

R 408.10570. Controls and interlocks.

Rule 570. (1) Control devices for a powered platform shall be a constant pressure type and shall be designed to prevent accidental actuation.

(2) Control devices shall be permanently labeled as to their function.

(3) Where a roof car is used, safety interlocks shall be provided to insure that the working platform will not leave the stored position until the required positive position anchor is engaged and to insure that the roof car cannot move when the working platform is not in the stored position.

R 408.10571. Safety factors.

Rule 571. All of the parts of a powered platform that are subject to stress, except for the wire rope, shall have a design safety factor of not less than 5. Wire rope shall have a design safety factor of not less than 10.

R 408.10572. Working platforms.

Rule 572. A working platform that is used on the exterior of a building shall be equipped with rollers which will be in contact with the building face. Where the vertical working travel of a working platform is more than 130 feet, the platform shall be equipped with guide rollers or guide shoes which shall positively engage guides, such as "t" rails or indented mullions. The guide rollers or guide shoes shall enter the guides at the lowest possible speed and shall not require any manual assistance from an employee while the work platform is in motion. A working platform which is installed before the effective date of this part and which has a rise of more than 130 feet may use an equivalent means to tie the platform to the building instead of guide rollers or guide shoes.

R 408.10573. Inspections and tests.

Rule 573. (1) An employer that has a powered platform under the employer's control shall do all of the following:

- (a) Provide operating instructions and a checklist for a visual inspection which shall be used by the operator before each daily use of the platform. The visual inspection shall include a check of the platform controls and safety interlocks.
- (b) Provide for a physical inspection, and service and repair when required, of the platform by a trained and authorized employee or an outside service every 30 days or before each use cycle if the equipment is used less often than every 30 days. The inspection, service, or repair shall be logged to show the date and the signature of the authorized employee or outside service and the work done.
- (c) Provide for inspections and operating tests not less than annually or after major alterations to determine that all components of the platform, including safety and operating equipment, are in compliance with the provisions of these rules. Such inspections and operating tests shall be made by a trained and authorized employee or outside service.

(2) A special inspection of platform governors and secondary brakes shall be made not less than annually by an authorized and trained employee or outside service to verify that the initiating device for the secondary brake operates at the proper overspeed. If a test cannot be made in the field, the initiating device or hoisting machine, or both, shall be removed from the building and sent to a shop that is equipped to make such a test. When the tested parts are reinstalled, the powered platform shall be reinspected before returning it to service.

R 408.10574. Maintenance.

Rule 574. (1) The following maintenance shall be performed, when required, during the 30-day inspection:

- (a) Replacement of any worn or defective parts noted during the inspections prescribed in R 408.10572.
- (b) Electrical connections shall be tightened and controller contacts and relays shall be cleaned.
- (c) Gears, shafts, bearings, brakes, and hoisting drums shall be aligned.

(2) Hoisting ropes shall be reshackled at the non-drum ends at least once every 2 years. In reshackling a rope, enough shall be cut from the end to remove damaged or fatigued portions. The rope shall be retagged and the limit switches reset, if necessary.

(3) Hoisting rope shall be replaced when there are 6 or more broken wires in any 1 lay or when the wire rope becomes damaged or is in a deteriorated condition.

R 408.10575. Hoisting machines; suspended equipment; 2 and 4-point suspended working platforms; single-point suspended platforms; ground-rigged working platforms; intermittently stabilized platforms; button-guide stabilized platforms; supported equipment; suspension wire ropes and rope connections.

Rule 575. (1) The raising and lowering of suspended or supported equipment shall be performed only by a hoisting machine.

(2) Each hoisting machine shall be capable of arresting any overspeed descent of the load.

(3) Each hoisting machine shall be powered only by air, electric, or hydraulic sources.

(4) Each hoisting machine shall be capable of raising or lowering 125% of the rated load of the hoist.

(5) Moving parts of a hoisting machine shall be enclosed or guarded in compliance with the provisions of general industry safety standard, Part 7. "Guards for Power Transmission," R 408.10701 to R 408.10765.

(6) Flammable liquids shall not be carried on the working platform.

(7) Winding drums, traction drums, and sheaves and directional sheaves that are used in conjunction with hoisting machines shall be sized for the wire rope that is used.

(8) Each winding drum shall be provided with a positive means of attaching the wire rope to the drum. The attachment shall be capable of developing not less than 4 times the rated load of the hoist.

(9) Each hoisting machine shall be provided with a primary brake and at least 1 independent secondary brake, each of which shall be capable of stopping and holding not less than 125% of the lifting capacity of the hoist. The primary brake shall be directly connected to the drivetrain of the hoisting machine and shall not be connected through belts, chains, clutches, or set screw-type devices. The brake shall automatically set when power to the prime mover is interrupted. The secondary brake shall be an automatic emergency type of brake that, if actuated during each stopping cycle, shall not engage before the hoist is stopped by the primary brake and shall stop and hold the platform within a vertical distance of 24 inches (609.6 mm).

(10) Any component of a hoisting machine that requires lubrication for its protection and proper functioning shall be provided with a means for that lubrication to be applied.

(11) All of the following provisions apply to suspended equipment:

- (a) Each suspended unit component, except for suspension ropes and guardrail systems, shall be capable of supporting not less than 4 times the maximum intended live load applied or transmitted to that component.
- (b) Each suspended unit component shall be constructed of materials that will withstand anticipated weather conditions.
- (c) Each suspended unit shall be provided with a load rating plate which is conspicuously located and which states the unit weight and rated load of the suspended unit.
- (d) When the suspension points on a suspended unit are not at the unit ends, the unit shall be capable of remaining continuously stable under all conditions of use and position of the live load and shall maintain not less than a 1.5 to 1 stability factor against unit upset.

- (e) Guide rollers, guide shoes, or building face rollers shall be provided and shall compensate for variations in building dimensions and for minor horizontal out-of-level variations of each suspended unit.
- (f) Each working platform of a suspended unit shall be secured to the building facade by 1 or more of the following methods or by an equivalent method that is in compliance with the provisions of R 408.10561 and R 408.10562:
 - (i) Continuous.
 - (ii) Intermittent.
 - (iii) Button guide engagement.
 - (iv) Angulated roping.
 - (v) Building face rollers.
- (g) Each working platform of a suspended unit shall be provided with a guardrail system on all sides, which shall meet the requirements of general industry safety standard, Part 2. "Floor and Wall Openings, Stairways, and Skylights," R 408.10201 to R 408.10241. All of the following provisions apply to the guardrail system:
 - (i) The system shall consist of a top guardrail, midrail, and toeboard.
 - (ii) The top guardrail shall be not less than 42 inches high and shall be able to withstand not less than a 200- pound force in any downward or outward direction.
 - (iii) The midrail shall be able to withstand not less than a 75-pound (333 n) force in any direction.
 - (iv) The areas between the guardrail and toeboard on the ends and outboard side, and the area between the midrail and toeboard on the inboard side, shall be closed with a material that is capable of withstanding a load of 100 pounds (45.4 kg.) applied horizontally over any area of 1 square foot (.09 m²). All openings in the material shall be small enough to prevent the passage of lifelines and potential falling objects that may be hazardous to persons below.
 - (v) Toeboards shall be capable of withstanding a force of not less than 50 pounds (222 n) applied in any direction at any point along the toeboard.
 - (vi) Toeboards shall be not less than 4 inches in height from the top edge to the level of the platform floor.
 - (vii) Toeboards shall be securely fastened in place at the outermost edge of the platform and have not more than 1/4 of an inch (1.3 cm) clearance above the platform.
 - (viii) Toeboards shall be solid or have an opening that is not more than 1 inch (2.5 cm) in the greatest dimension.
- (12)** All of the following provisions apply to a 2 and 4-point suspended working platform:
 - (a) The working platform shall be not less than 24 inches (610 mm) wide and shall be provided with a minimum of a 12-inch (305 mm) wide passage at or past any obstruction on the platform.
 - (b) The flooring shall be of a slip-resistant type and shall not have an opening that would allow the passage of lifelines, cables, and other potential falling objects.
 - (c) The working platform shall be provided with a means of suspension that will restrict the platform from tilting more than 15 degrees in any direction.

- (d) Any cable that is suspended from above the platform shall be provided with a means for storage to prevent accumulation of the cable on the floor of the platform.
 - (e) All operating controls for the vertical travel of the platform shall be of the continuous-pressure type and shall be located on the platform.
 - (f) Each operating station of every working platform shall be provided with a means of interrupting the power supply to all hoist motors to stop any further powered ascent or descent of the platform.
 - (g) The maximum rated speed of the platform shall not be more than 50 feet per minute (0.3 ms) for single-speed hoists and not more than 75 feet per minute (0.4 ms) for multispeed hoists.
 - (h) All tools, water tanks, and other accessories shall be secured to prevent their movement or accumulation on the floor of the platform.
 - (i) Portable fire extinguishers that are in compliance with the provisions of general industry safety standard, Part 8. "Portable Fire Extinguishers," R 408.10801 to R 408.10839, shall be provided and securely attached on all working platforms.
 - (j) Access to and egress from a working platform, except for those that land directly on a safe surface, shall be provided by stairs, ladders, platforms, and runways that are in compliance with the provisions of general industry safety standards, Part 2. "Floor and Wall Openings, Stairways, and Skylights," R 408.10201 to R 408.10241, and Part 4. "Portable Ladders," R 408.10401 to R 408.10456. Access gates shall be self-closing and self-latching.
 - (k) Means of access to or egress from a working platform that is 48 inches (1.2 m) or more above a safe surface shall be provided with a guardrail system or ladder-handrails that are in compliance with the provisions of general industry safety standards, Part 2. "Floor and Wall Openings, Stairways, and Skylights," R 408.10201 to R 408.10241, and Part 4. "Portable Ladders," R 408.10401 to R 408.10456.
 - (l) The platform shall be provided with a secondary wire rope suspension system if the platform has overhead structures that restrict the emergency egress of employees. A horizontal lifeline or a direct connection anchorage shall be provided as part of a fall arrest system. The system shall be in compliance with the requirements of general industry safety standard Part 33. "Personal Protective Equipment," R 408.10331 to R 408.13398.
 - (m) A vertical lifeline shall be provided as part of a fall arrest system. The system shall be in compliance with the requirements of general industry safety standard Part 33. "Personal Protective Equipment," R 408.10331 to R 408.10398, for each employee on a working platform that is suspended by 2 or more wire ropes if the failure of 1 wire rope or suspension attachment will cause the platform to upset. If a secondary wire rope suspension is used, vertical lifelines are still required for the fall arrest system.
 - (n) An emergency electric operating device shall be provided on roof-powered platforms near the hoisting machine for use in the event of failure of the normal operating device that is located on the working platform or failure of the cable that is connected to the platform. The emergency electric operating device shall be mounted in a secured compartment and the compartment shall be labeled with instructions for use. A means for opening the compartment shall be mounted on a break-glass receptacle that is located near the emergency electric operating device or in an equivalent secure accessible location.
- (13)** Both of the following provisions apply to a single-suspended working platform:
- (a) The requirements of R 408.10575(12)(a) to (k) shall also apply to a single-point working platform.
 - (b) Each single-point suspended working platform shall be provided with a secondary wire rope suspension system that will prevent the working platform from falling if there is a failure of the primary means of support or if the platform contains overhead structures that restrict the egress of the employees. A horizontal lifeline or a direct connection anchorage that meets the requirements of appendix c shall be provided, as part of a fall arrest system that is in compliance with the requirements of general industry safety standard Part 33. "Personal Protective Equipment," R 408.13301 to R 408.13398, for each employee on the platform.
- (14)** Both of the following provisions apply to a ground-rigged working platform:
- (a) The working platform shall be in compliance with all of the requirements of R 408.10575(12)(a) to (k).
 - (b) After each day's use, the power supply within the building shall be disconnected from a ground-rigged working platform, and the platform shall be either disengaged from its suspension points or secured and stored at grade.
- (15)** All of the following provisions apply to an intermittently stabilized platform:
- (a) The platform shall be in compliance with the requirements of R 408.10575(12)(a) to (m).
 - (b) Each stabilizer tie shall be equipped with a quick-connect/quick-disconnect device which cannot be accidentally disengaged, which is for attachment to the building anchor, and which is resistant to adverse environmental conditions.
 - (c) The platform shall be provided with a stopping device that will interrupt the hoist power supply if the platform contacts a stabilizer tie during its ascent.
 - (d) Building face rollers shall not be placed at the anchor setting if exterior anchors are used on the building face.
 - (e) Stabilizer ties that are used on intermittently stabilized platforms shall allow for the specific attachment length that is needed to effect the predetermined angulation of the suspended wire rope. The specific attachment length shall be maintained at all building anchor locations.
 - (f) The platform shall be in continuous contact with the face of the building during ascent and descent.
 - (g) The attachment and removal of stabilizer ties shall not require the horizontal movement of the platform.

- (h) The platform-mounted equipment and its suspension wire ropes shall not be physically damaged by the loads from the stabilizer tie or its building anchor. The platform, platform-mounted equipment, and wire ropes shall be able to withstand a load that is not less than twice the ultimate strength of the stabilizer tie.

(16) All of the following provisions apply to a button-guide stabilized platform:

- (a) The platform shall be in compliance with the requirements of R 408.10575(12)(a) to (m).
- (b) Each guide track on the platform shall engage a minimum of 2 guide buttons during any vertical travel of the platform after the initial button engagement.
- (c) Each guide track on a platform that is part of a roof-rigged system shall be provided with a storage position on the platform.
- (d) Each guide track on the platform shall be sufficiently maneuverable by platform occupants to permit easy engagement of the guide buttons and easy movement into and out of the guide track's storage position on the platform.
- (e) Two guide tracks shall be mounted on the platform and shall provide continuous contact with the building face.
- (f) The load-carrying components of the button guide stabilization system that transmit the load into the platform shall be capable of supporting the weight of the platform or provision shall be made in the guide track connectors or platform attachments to prevent the weight of the platform from being transmitted to the platform attachments.

(17) All of the following provisions apply to supported equipment:

- (a) Supported equipment shall maintain a vertical position in respect to the face of the building by means other than friction.
- (b) Cog wheels or equivalent means shall be incorporated to provide climbing traction between the supported equipment and the building guides. Additional guide wheels or shoes shall be incorporated as may be necessary to ensure that the drive wheels are continuously held in positive engagement with the building guides.
- (c) Launch guide mullions which are indexed to the building guides and which are retained in alignment with the building guides shall be used to align drive wheels that enter the building guides.
- (d) Manned platforms that are used on supported equipment shall be in compliance with the requirements of R 408.10575(12)(a), (b), and (d) to (k) with respect to suspended equipment.

(18) All of the following provisions apply to suspension wire ropes and rope connections:

- (a) Each specific installation shall use suspension wire ropes or combination cable and connections that are in compliance with the specifications recommended by the manufacturer of the hoisting machine that is used. Connections shall be capable of developing not less than 80% of the rated breaking strength of the wire rope.
- (b) Each suspension rope shall have a design factor of not less than 10. The design factor is the ratio of the rated strength of the suspension wire rope to the rated working load and shall be calculated using the following formula:

$$f = \frac{s(n)}{w}$$

where:

f = design factor

s = manufacturer's rated strength of 1 suspension rope.

n = number of suspension ropes under 1 load

w = rated working load on all ropes at any point of travel.

- (c) Suspension wire rope grade shall be at least improved plow steel or equivalent.
- (d) Suspension wire ropes shall be sized to be in compliance with the required design factor, but shall not be less than 5/16 of an inch (7.94 mm) in diameter.
- (e) A reverse bend in wire rope shall not be permitted.
- (f) A bend radius in wire rope shall not be less than 20 times the wire rope diameter.
- (g) Wire rope shall be inspected and maintained as specified in the provisions of R 408.10582.

R 408.10576. Tags.

Rule 576. (1) A corrosion-resistant tag shall be securely attached to 1 of the wire rope fastenings when a suspension wire rope is to be used at a specific location and will remain in that location. This tag shall bear all of the following wire rope data:

- (a) The diameter in inches or millimeters, or both.
- (b) Construction classification.
- (c) Whether nonpreformed or preformed.
- (d) The grade of materials.
- (e) The manufacturer's rated strength.
- (f) The manufacturer's name.
- (g) The month and year the ropes were installed.
- (h) The name of the person or company that installed the ropes.

(2) A new tag shall be installed at each rope renewal.

(3) The original tag shall be stamped with the date of the restocking or the original tag shall be retained and a supplemental tag shall be provided when ropes are restocked. The supplemental tag shall show the date of restocking and the name of the person or company that restocked the rope.

(4) Winding drum-type hoists shall contain not less than 3 wraps of the suspension wire rope on the drum when the suspended unit has reached the lowest possible point of its vertical travel.

(5) Traction drum and sheave-type hoists shall be provided with a wire rope that is of a sufficient length to reach the lowest possible point of vertical travel of the suspended unit and with an additional length of the wire rope that is not less than 4 feet (1.2 m). The lengthening or repairing of suspension wire rope is prohibited. Babbitted fastenings for suspension wire rope are prohibited.

R 408.10577 Compliance with material electrical code required; exception; electrical runway conductors; cable protection; electrical overload protection.

Rule 577. (1) Electrical wiring and equipment shall be in compliance with the requirements specified in section 1910.309 of the national electrical code, except as otherwise required by these rules.

(2) An electrical runway conductor system shall be of a type that is designed for use in exterior locations and shall be located so that the system does not come into contact with accumulated snow or water.

(3) Cables shall be protected against damage that results from overtensioning or from other causes.

(4) Devices shall be included in the control system for the equipment which will provide protection against electrical overloads, 3-phase reversal, and phase failure. The control system shall have a separate method, which shall be independent of the direction control circuit, for breaking the power circuit if there is an emergency or malfunction.

(5) Suspended or supported equipment shall have a control system that will require the operator of the equipment to follow predetermined procedures.

(6) All of the following requirements apply to electrical protection devices:

- (a) On installations where the carriage does not have a stability factor of at least 4 against overturning, an electrical contact or contacts shall be provided and connected so that the operating devices for the suspended or supported equipment shall be operative only when the carriage is located and mechanically retained at an established operating point.
- (b) Overload protection shall be provided in the hoisting or suspension system to protect against the equipment operating in the "up" direction with a load of more than 125% of the rated load of the platform.
- (c) An automatic detector shall be provided for each suspension point which will interrupt power to all hoisting motors for travel in the "down" direction and which will apply the primary brakes if any suspension wire rope becomes slack. A continuous-pressure rigging-bypass switch that is designed for use during rigging is permitted. This switch shall only be used by authorized personnel during rigging.
- (d) Upper and lower directional switches that are designed to prevent the travel of suspended units beyond safe upward and downward levels shall be provided.
- (e) Emergency stop switches shall be provided on remote controlled, roof-powered platforms that are adjacent to each control station on the platform.
- (f) Cables that are in constant tension shall have overload devices which will prevent the tension in the cable from interfering with the load-limiting device or with the platform roll-limiting device. The setting of these devices shall be coordinated with other overload settings at the time the system is designed and shall be clearly indicated on or near the device. The device shall interrupt the equipment travel in the "down" direction.

R 408.10578. Installation and alteration; inspections and tests.

Rule 578. All completed building maintenance equipment installations shall be inspected and tested in the field before being placed in initial service to determine that all parts of the installation are in compliance with applicable requirements of these rules, and that all safety and operating equipment is functioning as required. A similar inspection and test shall be made after any major alteration to an existing installation. A hoist in an installation shall not be subjected to a load that is more than 125% of its rated load.

R 408.10579. Inspection of related building supporting structures; equipment inspection and testing intervals; certification record; employer inspection of platforms.

Rule 579. (1) Related building supporting structures shall undergo periodic inspection by a competent person at intervals of not more than 12 months.

(2) All parts of the equipment, including control systems, shall be inspected and, where necessary, tested by a competent person at intervals specified by the manufacturer and supplier, but not more than 12 month intervals, to determine that equipment parts are in safe operating condition. Parts that are subject to wear, such as wire ropes, bearings, gears, and governors, shall be inspected or tested to determine that they have not worn to such an extent as to affect the safe operation of the installation.

(3) The owner shall keep a certification record of each inspection and test required. The record shall include all of the following information:

- (a) The date of the inspection.
- (b) The signature of the person who performed the inspection.
- (c) The number, or other identifier, of the building support structure and equipment that was inspected.

This certification record shall be kept readily available for review by the director of the Michigan department of consumer and industry services or his or her representative and by the employer.

(4) Working platforms and their components shall be inspected by the employer for visible defects before every use and after each occurrence that could affect the platform's structural integrity.

R 408.10580. Intervals of maintenance inspections and tests; certification record.

Rule 580. (1) A maintenance inspection and, where necessary, a test shall be made of each platform installation every 30 days. If the work cycle is less than 30 days, such inspection and test shall be made before each work cycle. This inspection and test shall follow the procedures recommended by the manufacturer and shall be made by a competent person.

(2) The building owner shall keep a certification record of each inspection and test performed. The record shall contain all of the following information:

- (a) The date of the inspection and test.
- (b) The signature of the person who performed the inspection or test.
- (c) An identifier for the platform installation that was inspected.

The certification record shall be kept readily available for review by the director of the Michigan department of consumer and industry services or his or her designated representative and by the employer.

R 408.10581. Special inspection of governors and secondary brakes.

Rule 581. (1) Governors and secondary brakes shall be inspected and tested at intervals specified by the manufacturer and supplier, but the interval shall not be more than every 12 months.

(2) The results of the inspection and test shall confirm that the initiating device for the secondary braking system operates at the proper overspeed.

(3) The results of the inspection and test shall confirm that the secondary brake is functioning properly.

(4) If any hoisting machine or initiating device for the secondary brake system is removed from the equipment for testing, all reinstalled and directly related components shall be reinspected before returning the equipment installation to service.

(5) Inspection of governors and secondary brakes shall be performed by a competent person.

(6) The secondary brake governor and actuation device shall be tested before each daily use. Where testing is not feasible, a visual inspection of the brake shall be made to ensure that it is free to operate.

WIRE, FIBER, AND SYNTHETIC ROPE

R 408.10582. Wire rope; reinforcement; use of metal thimble, end fittings; requirements for use of wire clips; cutting preparation; lubrication; use of suspension wire rope to follow procedures recommended by manufacturer; inspection of suspension wire rope; certification record.

Rule 582. (1) Wire rope for a scaffold shall be replaced if any of the following conditions exists:

- (a) In any length of 8 diameters, the total number of visible broken wires is more than 6 in 1 rope lay or 3 wires in 1 strand.
- (b) The wire rope has been kinked, crushed, or bird-caged or has sustained any other damage that distorts the wire rope structure.
- (c) The wire rope shows heat or corrosive damage.
- (d) The wire rope contains a broken wire within 18 inches (460.8 mm) of the end attachment.

(2) Wire rope that is bent to form an eye over a bolt or rod which has a diameter that is less than 4 times the rope diameter shall be equipped with a metal thimble.

(3) End fittings should be swagged or zinc-poured sockets.

(4) Where wire clips are used, the provisions of table 8 shall be followed and the u-bolts shall be installed on the dead end or short end of the wire rope.

(5) Wire rope shall be stored in a manner to prevent damage or deterioration.

(6) Before cutting wire rope, a seizing shall be placed on each side of the cut on preformed wire rope, 2 seizings shall be placed on each side of 7/8 inch size or smaller nonpreformed wire rope, and 3 seizings shall be placed on each side of 1 inch or larger size nonpreformed wire rope.

(7) Wire rope shall be maintained in a lubricated condition over its entire length with the same type of lubricant that is used by the manufacturer.

(8) Suspension wire ropes shall be maintained and used in accordance with the procedures recommended by the wire rope manufacturer.

(9) Suspension wire rope shall be inspected by a competent person for visible defects and gross damage to the rope before every use and after each occurrence that might affect the wire rope's integrity.

(10) A thorough inspection of suspension wire ropes in service shall be made once a month. Suspension wire ropes that have been inactive for 30 days or more shall have a thorough inspection before they are placed into service. These thorough inspections of suspension wire ropes shall be performed by a competent person.

(11) The need for replacement of suspension wire rope shall be based on its condition. A wire rope shall be removed for any of the following conditions:

- (a) Evidence of core failure. A lengthening of rope lay, protrusion of the rope core, and a reduction in rope diameter suggests core failure.

(b) Outer wire wear is more than 1/3 of the original outer wire diameter.

(c) Any other condition that the competent person determines has significantly affected the integrity of the rope.

(12) The owner shall keep a certification record of each monthly inspection of a suspension wire rope which shall be verified by the employer. The record shall include the date of the inspection and a number or other identifier of the wire rope that was inspected. The record of inspection shall be made available for review by the director of the Michigan department of consumer and industry services or his or her designated representative and by the employer.

R 408.10583. Fiber rope; inspection; storage; drying of wet rope; use prohibited under certain conditions; replacement; use of thimble.

Rule 583. (1) A fiber rope shall be inspected visually before the start of each daily use as follows:

- (a) Externally for any of the following conditions:
 - (i) Abrasions.
 - (ii) Cut or broken fibers.
 - (iii) Decay.
 - (iv) Burns.
 - (v) Lack of strength.
 - (vi) Softness.
 - (vii) Variation in size or roundness of the strands.
- (b) Internally, by separating the strands at 3 foot intervals, for any of the following conditions:
 - (i) Broken fibers.
 - (ii) Presence of grit.
 - (iii) Mildew or mold.
 - (iv) Color change of the fibers.
 - (v) Powdering.
 - (vi) Short loose fibers.

A rope that has any of the conditions specified in this rule shall be replaced or returned to the manufacturer for repair.

(2) A fiber rope shall be stored in a dry room in coils or on a reel.

(3) A wet fiber rope shall be dried by placing it in the sunshine or a warm room hanging loosely over a rounded peg or hook.

(4) A fiber rope shall not be kinked or run over sharp corners, shall not be used when frozen, and shall not be left in freezing temperatures when wet.

(5) A fiber rope that is subjected to an impact load that is equal to or more than its rated capacity shall be replaced.

(6) A thimble shall be used with fiber rope pursuant to the provisions of R 408.10581(2).

R 408.10584. Synthetic rope; inspection; condition of use; replacement; use of thimble.

Rule 584. (1) A synthetic rope shall be inspected visually before the start of each job for all of the following conditions:

- (a) Abrasions.
- (b) Cut or broken fibers.
- (c) Burns.
- (d) Melted fibers.
- (e) Variation in size or roundness of the strands. A rope that has any of these conditions shall be replaced or returned to the manufacturer for repair.

(2) Because of the variance in manufacturing methods, the manufacturer's recommendations shall be followed.

(3) A synthetic rope shall not be kinked, run over sharp corners, used when frozen, or left in freezing temperatures when wet.

(4) A synthetic rope that is subjected to an impact load that is equal to or more than its rated capacity shall be replaced.

(5) A thimble shall be used with synthetic rope pursuant to the provisions of R 408.10581 (2).

R 408.10585. Hoist inspection; general maintenance; cleaning.

Rule 585. (1) Before lowering personnel below the top elevation of the building, a hoist shall be tested each day in the lifting direction with the intended load to make certain it has sufficient capacity to raise the personnel back to the boarding level.

(2) All parts of the equipment that affect the safe operation of a hoist shall be maintained in proper working order so that the parts perform the functions for which they were intended. The equipment shall be taken out of service when it is not in proper working order.

(3) Control or power contacts and relays shall be kept clean.

(4) All other equipment parts shall be kept clean if their proper functioning would be affected by the presence of dirt or other contaminants.

R 408.10586. Periodic resocking of wire rope fastenings.

Rule 586. (1) Hoisting ropes that utilize poured socket fastenings shall be resocked at the non-drum ends at intervals of not more than 24 months. In resocking the ropes, a sufficient length shall be cut from the end of the rope to remove damaged or fatigued portions.

(2) Resocked ropes shall be in compliance with the requirements of R 408.10582.

(3) Limit switches that are affected by the resocked ropes shall be reset, if necessary.

R 408.10587. Roof systems; maintenance.

Rule 587. Roof track systems, tie downs, and similar equipment shall be maintained in proper working order so that they perform the functions for which they were intended.

R 408.10588. Building face guiding members; maintenance.

Rule 588. T-rails, indented mullions, and equivalent guides that are located in the face of a building shall be maintained in proper working order so that they perform the functions for which they were intended. Brackets for cable stabilizers shall similarly be maintained in proper working order.

R 408.10589. Rendering safety devices inoperative prohibited; exception.

Rule 589. A person shall not render a required safety device or electrical protective device inoperative, except as necessary for tests, inspections, and maintenance. Immediately upon completion of such tests, inspections, and maintenance, the device shall be restored to its normal operating condition.

R 408.10590. Platform operator training.

Rule 590. (1) Working platforms shall be operated only by persons who are proficient in the operation, safe use, and inspection of the particular working platform to be operated.

(2) All employees who operate working platforms shall be trained in all of the following areas:

- (a) Recognition of, and preventative measures for, the safety hazards that are associated with the employee's individual work tasks.
- (b) General recognition and prevention of safety hazards that are associated with the use of working platforms.
- (c) Emergency action plan procedures.
- (d) Work procedures.

(e) Personal fall arrest system inspection, care, use, and system performance.

(3) The training of employees in the operation and inspection of working platforms shall be done by a competent person.

(4) Written work procedures for the operation, safe use, and inspection of working platforms shall be provided for employee training. Pictorial methods of instruction may be used in place of written work procedures if employee communication is improved through the use of this method. The operating manuals that are supplied by the manufacturers for platform system components can serve as the basis for these procedures.

(5) An employer shall certify that employees have been trained in the operation and inspection of a working platform by preparing a certification record that includes all of the following information:

- (a) The identity of the person trained.
- (b) The signature of the employer or the person who conducted the training.
- (c) The date that training was completed.

The certification record shall be prepared at the completion of the training and shall be maintained in a file for the duration of the employee's employment. The certification record shall be kept readily available for review by the director of the Michigan department of consumer and industry services or his or her designated representative.

R 408.10591. Platform load; work on platforms covered with certain materials prohibited; exception; protective precautions; operation of platform under certain wind conditions prohibited; use of anemometer required; accumulation of tools, materials, or debris prohibited; stabilizer ties.

Rule 591. (1) Working platforms shall not be loaded in excess of the rated load as stated on the platform load rating plate.

(2) Employees shall be prohibited from working on snow, ice, or other slippery material that covers a platform, except to remove such materials.

(3) Adequate precautions shall be taken to protect the platform, wire ropes, and lifelines from damage due to acids or other corrosive substances. The precautions taken shall be in accordance with the recommendations of the corrosive substance producer, supplier, platform manufacturer, or other equivalent information sources. Platform members that have been exposed to acids or other corrosive substances shall be washed down after each use with a neutralizing solution at a frequency recommended by the corrosive substance producer or supplier.

(4) Platform members, wire ropes, and lifelines shall be protected when using a heat-producing process. Wire ropes and life lines that have been contacted by the heat-producing process shall be considered to be permanently damaged and shall not be used.

(5) A platform shall not be operated in winds of more than 25 miles per hour (40.2 km/hr), except to move the platform from an operating to a storage position. Wind speed shall be determined based on the best available information, which includes on-site anemometer readings and local weather forecasts that predict wind velocities for the area.

(6) On exterior installations, an anemometer shall be mounted on the platform to determine on-site wind velocities before and during use of the platform. The anemometer may be a portable (hand-held) unit that is temporarily mounted during platform use.

(7) Tools, materials, and debris that are not related to the work in progress shall not be allowed to accumulate on platforms. Stabilizer ties shall be located so as to allow unencumbered passage along the full length of the platform and shall be of such length so as not to become entangled in rollers, hoists, or other machinery.

R 408.10592. Personal fall protection.

Rule 592. Employees on working platforms shall be protected by a personal fall arrest system that is in compliance with the requirements of general industry safety standard Part 33. "Personal Protective Equipment," R 408.13301 to R 408.13398.

APPENDIX

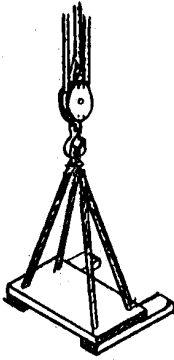

Boatswain's Chair
Example 1

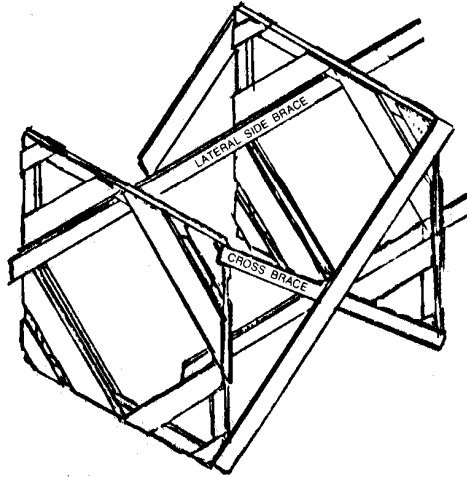

Bricklayer's Square Scaffold
Example 2

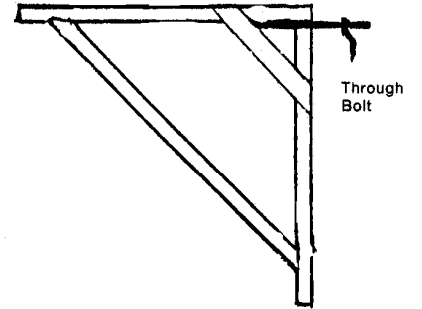

Carpenter's Bracket Scaffold
Example 3

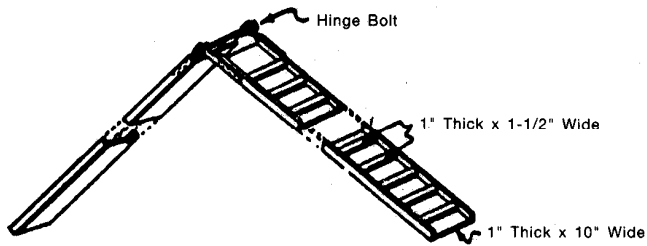

Crawling Board
Example 4

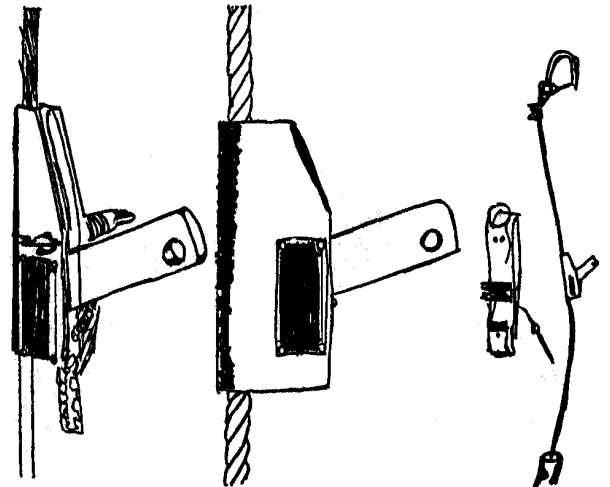

Fall Prevention Device
Example 5

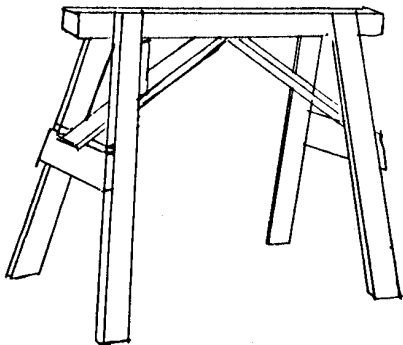

Horse Scaffold
Example 6

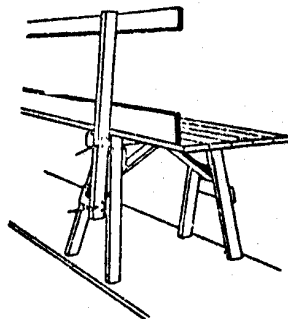

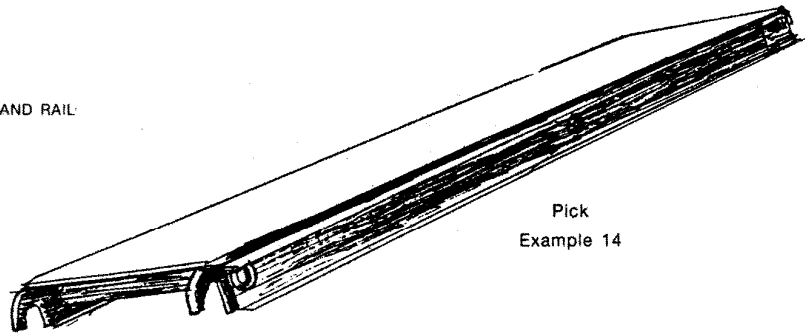
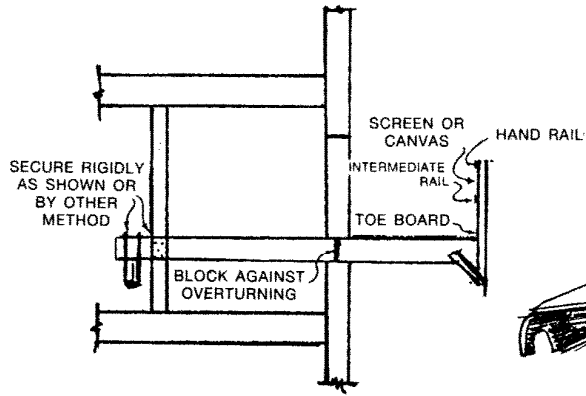

Pick Example 14

Outrigger Scaffold Example 13

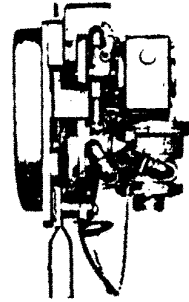
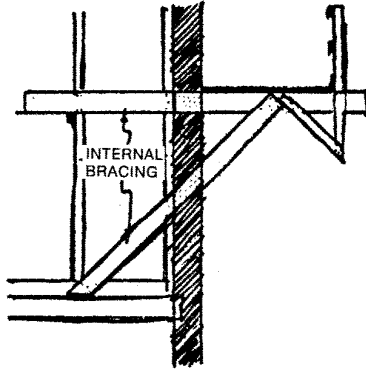

Air Powered Hoisting Machine

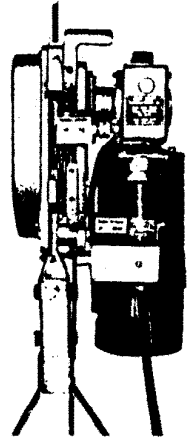

Electric Powered Hoisting Machine

Example 15

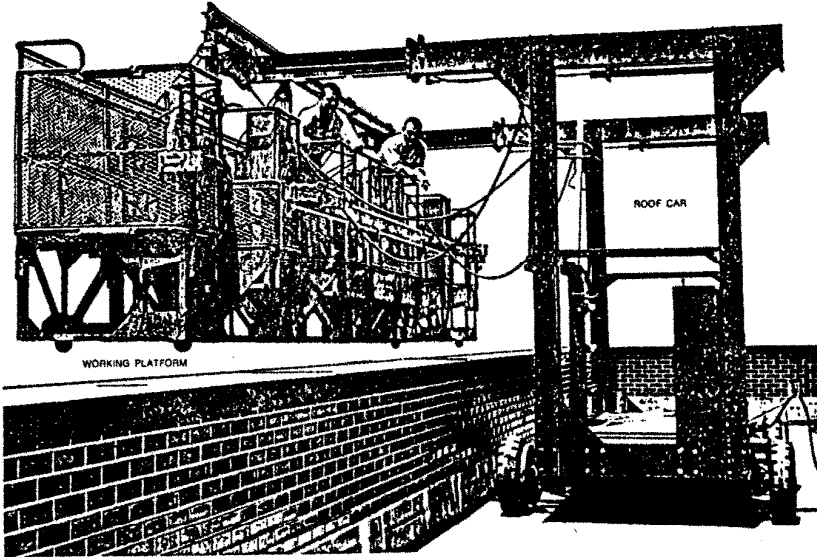

Powered Platform Example 16

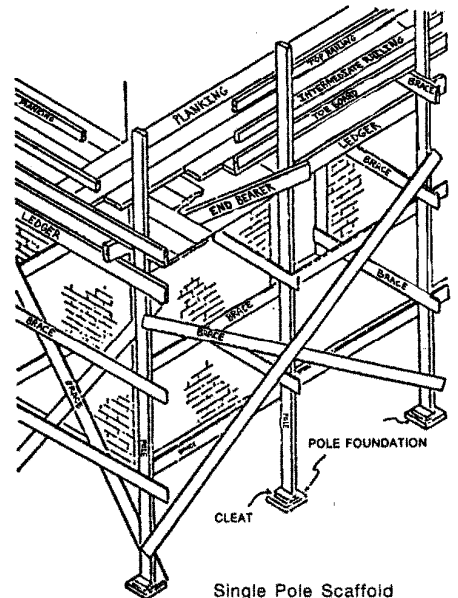

Single Pole Scaffold Example 18

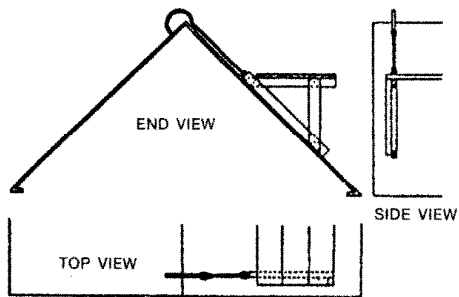

Roof Bracket



Roof Bracket Hooks

Example 17

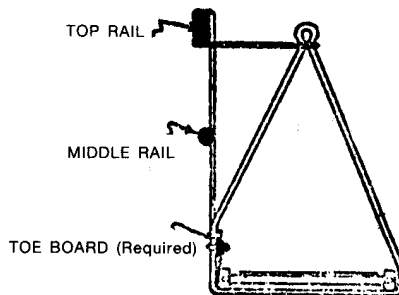
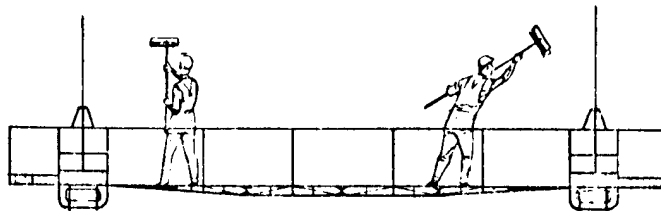
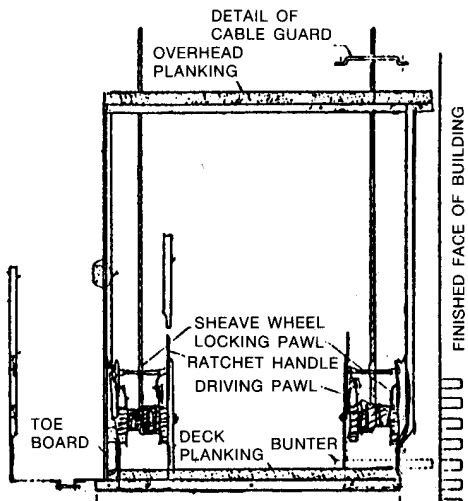

Swing Scaffold
Example 20

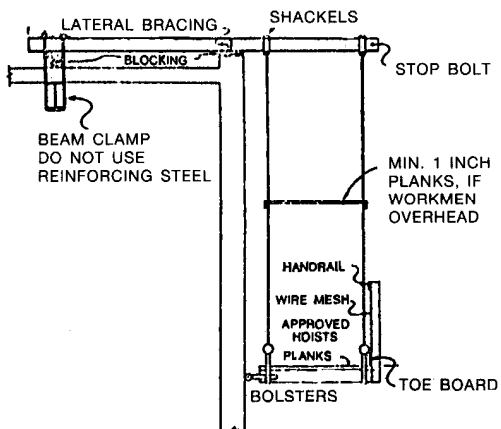

Suspension Scaffold
Example 19

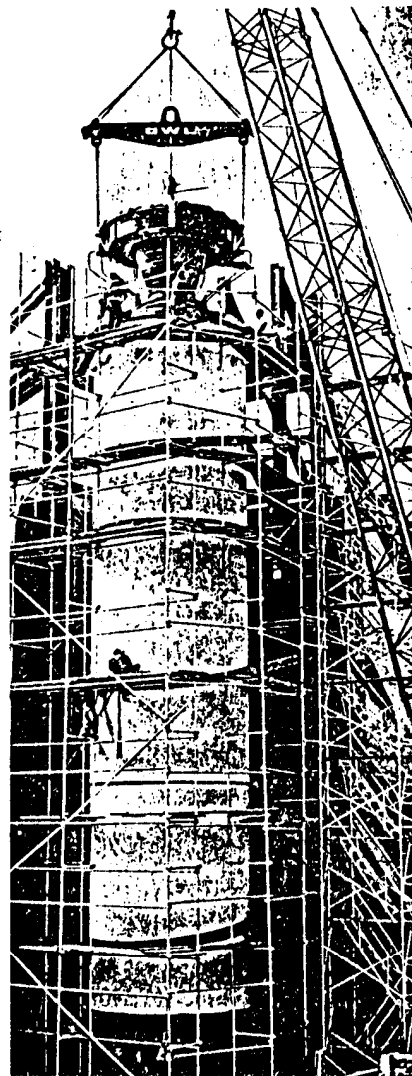
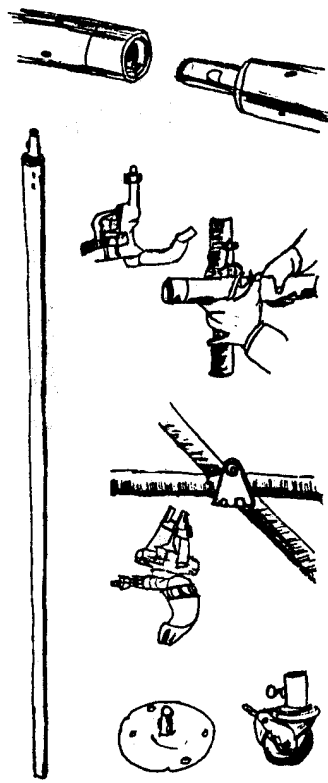

Tube and Coupler Type Scaffold
Example 21

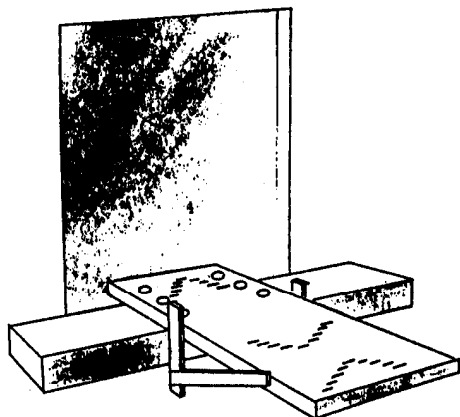

Window Jack Scaffold
Example 22

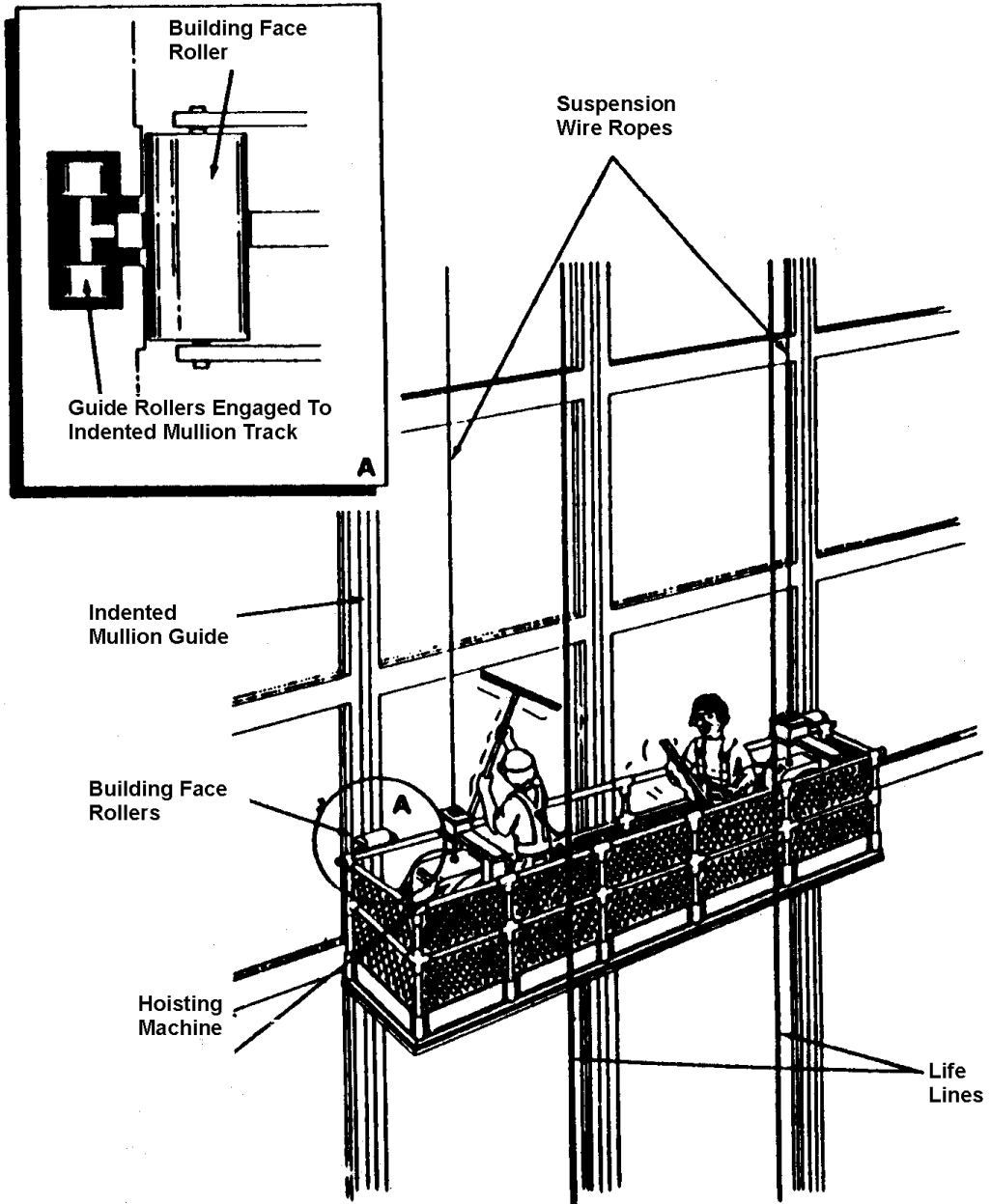

Typical Self-Powered Platform-Continuous
External or Indented Mullion Guide System
Example 23

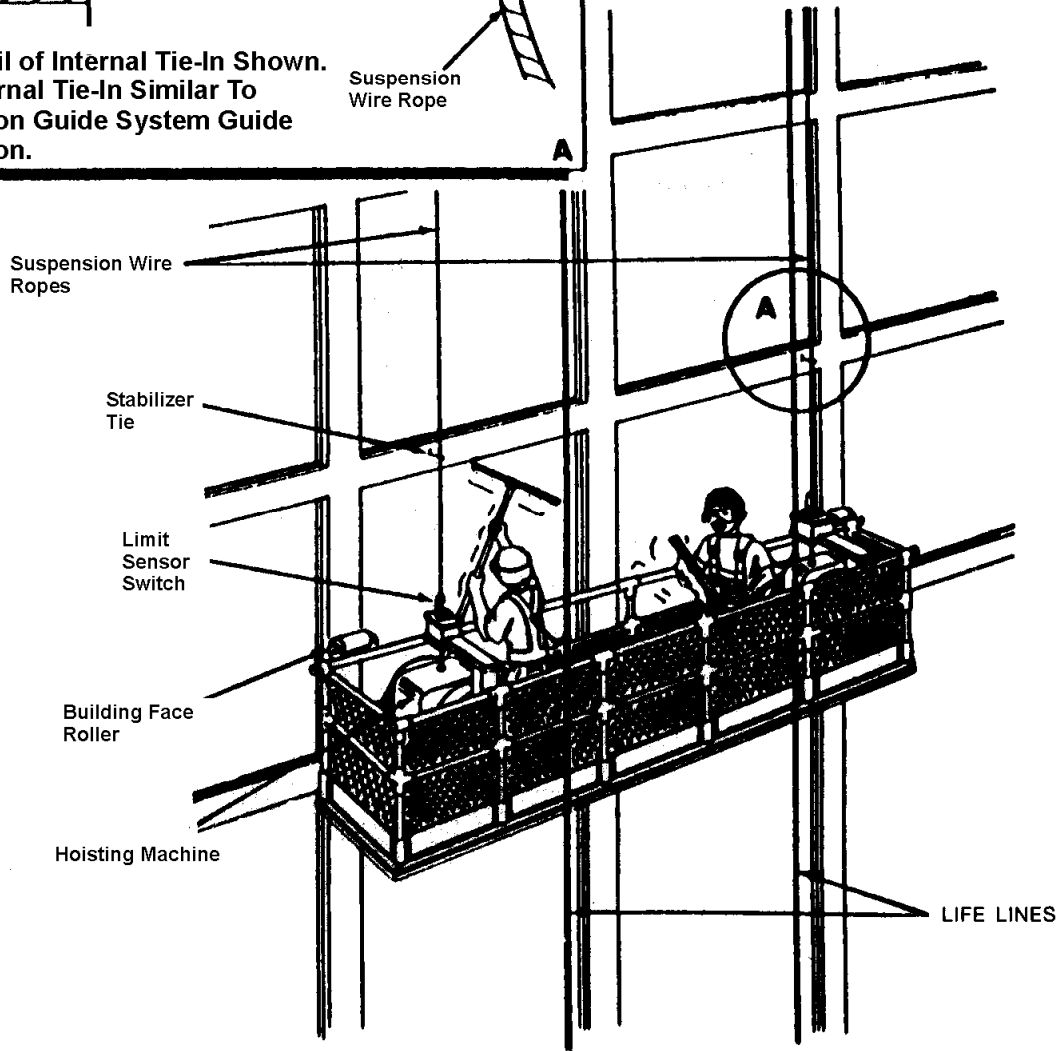
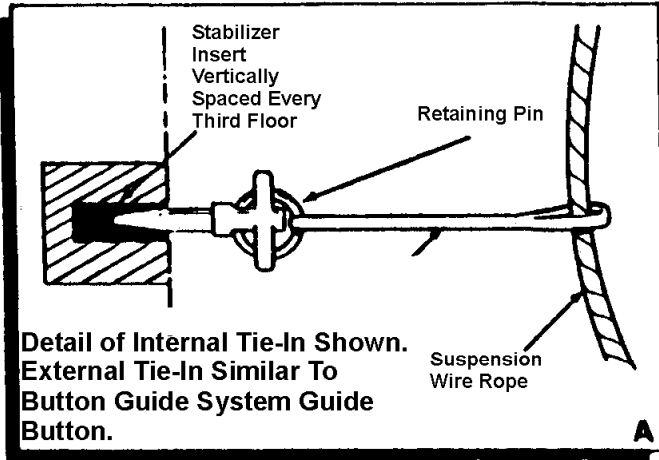

Typical Self-Powered
Platform-Intermittent Tie-in System
Example 24

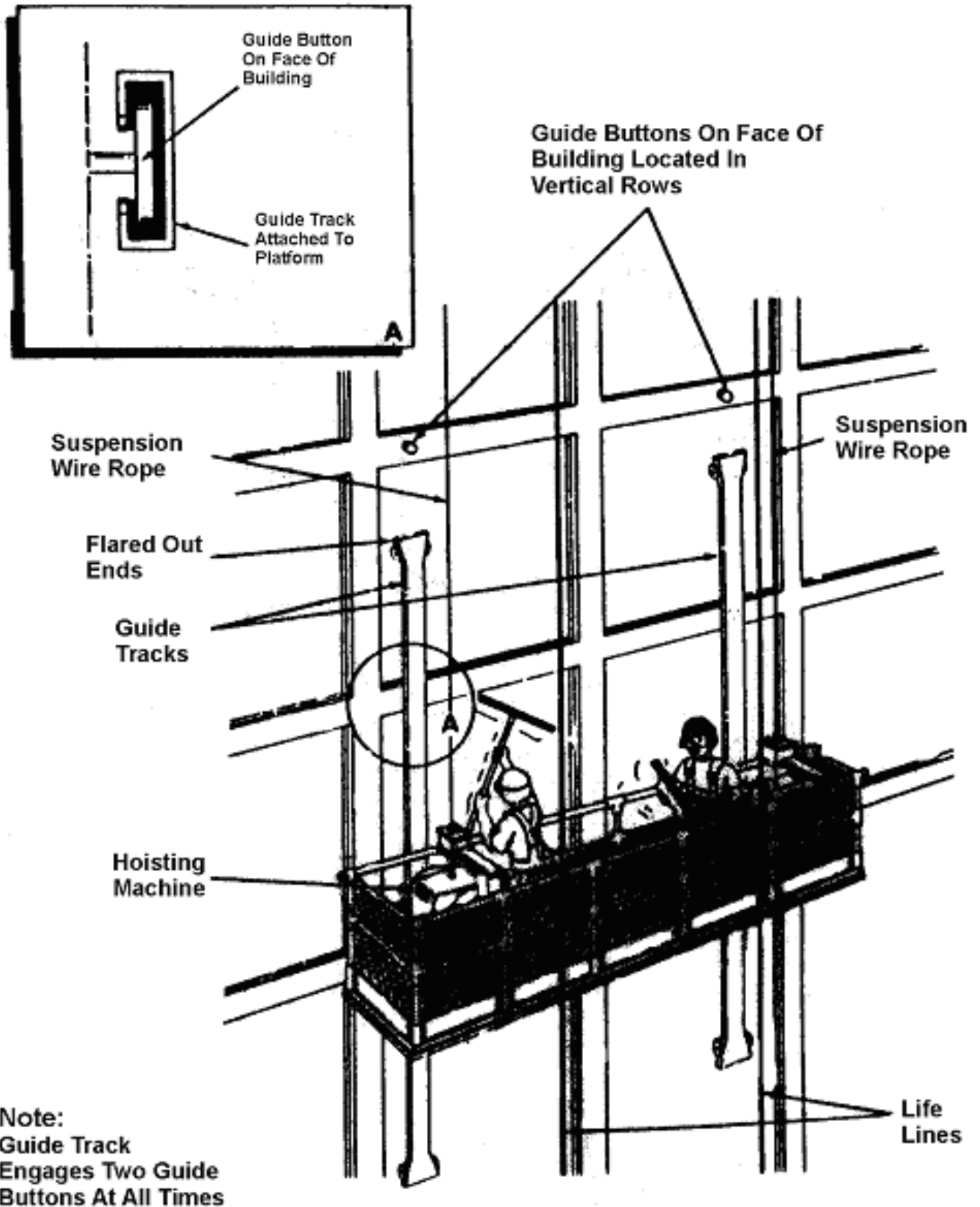

Typical Self-Powered
Platform-Button Guide System
Example 25



For further information contact
Michigan Occupational Safety and Health Administration
PO Box 30643
Lansing, Michigan 48909-8143
Ph: 517.322.1845

The Department of Licensing and Regulatory Affairs will not discriminate against any individual or group because of race, sex, religion, age, national origin, color, marital status, disability, or political beliefs. Auxiliary aids, services and other reasonable accommodations are available upon request to individuals with disabilities.