

Michigan Register

Issue No. 11 – 2009 (Published July 1, 2009)

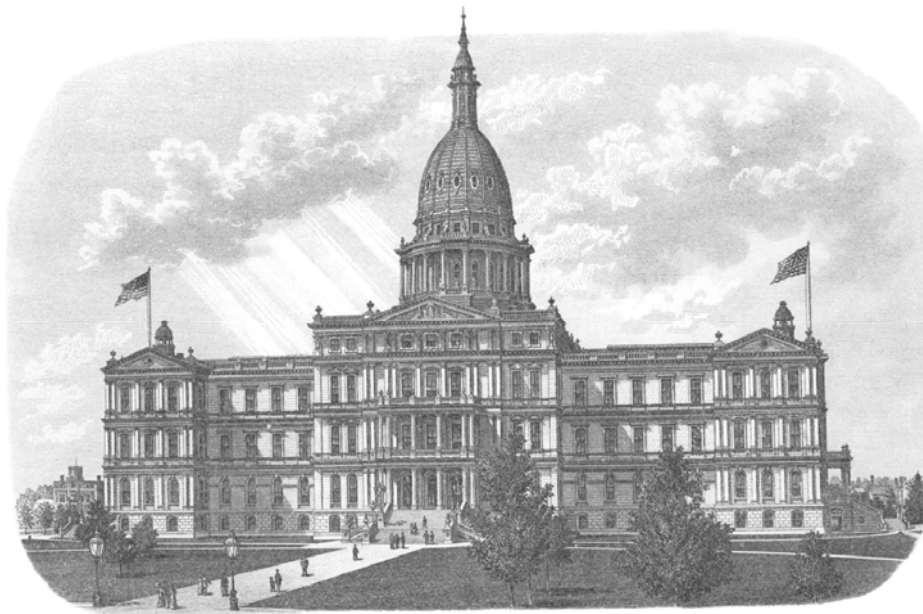

GRAPHIC IMAGES IN THE MICHIGAN REGISTER

COVER DRAWING

Michigan State Capitol:

This image, with flags flying to indicate that both chambers of the legislature are in session, may have originated as an etching based on a drawing or a photograph. The artist is unknown. The drawing predates the placement of the statue of Austin T. Blair on the capitol grounds in 1898.

(Michigan State Archives)

PAGE GRAPHICS

Capitol Dome:

The architectural rendering of the Michigan State Capitol's dome is the work of Elijah E. Myers, the building's renowned architect. Myers inked the rendering on linen in late 1871 or early 1872. Myers' fine draftsmanship, the hallmark of his work, is clearly evident.

Because of their size, few architectural renderings of the 19th century have survived. Michigan is fortunate that many of Myers' designs for the Capitol were found in the building's attic in the 1950's. As part of the state's 1987 sesquicentennial celebration, they were conserved and deposited in the Michigan State Archives.

(Michigan State Archives)

East Elevation of the Michigan State Capitol:

When Myers' drawings were discovered in the 1950's, this view of the Capitol – the one most familiar to Michigan citizens – was missing. During the building's recent restoration (1989-1992), this drawing was commissioned to recreate the architect's original rendering of the east (front) elevation.

(Michigan Capitol Committee)

Michigan Register

Published pursuant to § 24.208 of
The Michigan Compiled Laws



Issue No. 11— 2009

(This issue, published July 1, 2009, contains
documents filed from June 1, 2009 to June 15, 2009)

Compiled and Published by the
State Office of Administrative Hearings and Rules

© 2009 by State Office of Administrative Hearings and Rules, State of Michigan
All rights reserved.
Printed in the United States of America

Michigan Register (ISSN 0892-3124). Published twice per month, with a cumulative index, by the State Office of Administrative Hearings and Rules, pursuant to §24.208 of the Michigan Compiled Laws. Subscription \$400.00 per year, postpaid to points in the U.S. First class postage paid at Lansing, Michigan. Direct all mail concerning subscriptions to State Office of Administrative Hearings and Rules, Ottawa Building - Second Floor, 611 W. Ottawa, P.O. Box 30695, Lansing, MI 48933

Peter Plummer, Executive Director, State Office of Administrative Hearings and Rules; **Deidre O'Berry**, Administrative Rules Analyst for Operations and Publications.

Jennifer M. Granholm, Governor

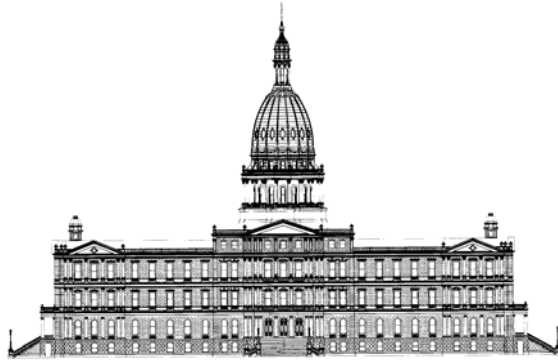

John D. Cherry Jr., Lieutenant Governor

PREFACE

PUBLICATION AND CONTENTS OF THE MICHIGAN REGISTER

The State Office of Administrative Hearings and Rules publishes the *Michigan Register*.

While several statutory provisions address the publication and contents of the *Michigan Register*, two are of particular importance.

24.208 Michigan register; publication; cumulative index; contents; public subscription; fee; synopsis of proposed rule or guideline; transmitting copies to office of regulatory reform.

Sec. 8.

(1) The office of regulatory reform shall publish the Michigan register at least once each month. The Michigan register shall contain all of the following:

- (a) Executive orders and executive reorganization orders.
- (b) On a cumulative basis, the numbers and subject matter of the enrolled senate and house bills signed into law by the governor during the calendar year and the corresponding public act numbers.
- (c) On a cumulative basis, the numbers and subject matter of the enrolled senate and house bills vetoed by the governor during the calendar year.
- (d) Proposed administrative rules.
- (e) Notices of public hearings on proposed administrative rules.
- (f) Administrative rules filed with the secretary of state.
- (g) Emergency rules filed with the secretary of state.
- (h) Notice of proposed and adopted agency guidelines.
- (i) Other official information considered necessary or appropriate by the office of regulatory reform.
- (j) Attorney general opinions.
- (k) All of the items listed in section 7(m) after final approval by the certificate of need commission under section 22215 of the public health code, 1978 PA 368, MCL 333.22215.

(2) The office of regulatory reform shall publish a cumulative index for the Michigan register.

(3) The Michigan register shall be available for public subscription at a fee reasonably calculated to cover publication and distribution costs.

(4) If publication of an agency's proposed rule or guideline or an item described in subsection (1)(k) would be unreasonably expensive or lengthy, the office of regulatory reform may publish a brief synopsis of the proposed rule or guideline or item described in subsection (1)(k), including information on how to obtain a complete copy of the proposed rule or guideline or item described in subsection (1)(k) from the agency at no cost.

(5) An agency shall electronically transmit a copy of the proposed rules and notice of public hearing to the office of regulatory reform for publication in the Michigan register.

4.1203 Michigan register fund; creation; administration; expenditures; disposition of money received from sale of Michigan register and amounts paid by state agencies; use of fund; price of Michigan register; availability of text on internet; copyright or other proprietary interest; fee prohibited; definition.

Sec. 203.

- (1) The Michigan register fund is created in the state treasury and shall be administered by the office of regulatory reform. The fund shall be expended only as provided in this section.
- (2) The money received from the sale of the Michigan register, along with those amounts paid by state agencies pursuant to section 57 of the administrative procedures act of 1969, 1969 PA 306, MCL 24.257, shall be deposited with the state treasurer and credited to the Michigan register fund.
- (3) The Michigan register fund shall be used to pay the costs of preparing, printing, and distributing the Michigan register.
- (4) The department of management and budget shall sell copies of the Michigan register at a price determined by the office of regulatory reform not to exceed the cost of preparation, printing, and distribution.
- (5) Notwithstanding section 204, beginning January 1, 2001, the office of regulatory reform shall make the text of the Michigan register available to the public on the internet.
- (6) The information described in subsection (5) that is maintained by the office of regulatory reform shall be made available in the shortest feasible time after the information is available. The information described in subsection (5) that is not maintained by the office of regulatory reform shall be made available in the shortest feasible time after it is made available to the office of regulatory reform.
- (7) Subsection (5) does not alter or relinquish any copyright or other proprietary interest or entitlement of this state relating to any of the information made available under subsection (5).
- (8) The office of regulatory reform shall not charge a fee for providing the Michigan register on the internet as provided in subsection (5).
- (9) As used in this section, "Michigan register" means that term as defined in section 5 of the administrative procedures act of 1969, 1969 PA 306, MCL 24.205.

CITATION TO THE MICHIGAN REGISTER

The *Michigan Register* is cited by year and issue number. For example, 2001 MR 1 refers to the year of issue (2001) and the issue number (1).

CLOSING DATES AND PUBLICATION SCHEDULE

The deadlines for submitting documents to the State Office of Administrative Hearings and Rules for publication in the *Michigan Register* are the first and fifteenth days of each calendar month, unless the submission day falls on a Saturday, Sunday, or legal holiday, in which event the deadline is extended to include the next day which is not a Saturday, Sunday, or legal holiday. Documents filed or received after 5:00 p.m. on the closing date of a filing period will appear in the succeeding issue of the *Michigan Register*.

The State Office of Administrative Hearings and Rules is not responsible for the editing and proofreading of documents submitted for publication.

Documents submitted for publication should be delivered or mailed in an electronic format to the following address: MICHIGAN REGISTER, State Office of Administrative Hearings and Rules, Ottawa Building - Second Floor, 611 W. Ottawa, P.O. Box 30695, Lansing, MI 48933.

RELATIONSHIP TO THE MICHIGAN ADMINISTRATIVE CODE

The *Michigan Administrative Code* (1979 edition), which contains all permanent administrative rules in effect as of December 1979, was, during the period 1980-83, updated each calendar quarter with the publication of a paperback supplement. An annual supplement contained those permanent rules, which had appeared in the 4 quarterly supplements covering that year.

Quarterly supplements to the Code were discontinued in January 1984, and replaced by the monthly publication of permanent rules and emergency rules in the *Michigan Register*. Annual supplements have included the full text of those permanent rules that appear in the twelve monthly issues of the *Register* during a given calendar year. Emergency rules published in an issue of the *Register* are noted in the annual supplement to the Code.

SUBSCRIPTIONS AND DISTRIBUTION

The *Michigan Register*, a publication of the State of Michigan, is available for public subscription at a cost of \$400.00 per year. Submit subscription requests to: State Office of Administrative Hearings and Rules, Ottawa Building - Second Floor, 611 W. Ottawa, P.O. Box 30695, Lansing, MI 48933. Checks Payable: State of Michigan. Any questions should be directed to the State Office of Administrative Hearings and Rules (517) 335-2484.

INTERNET ACCESS

The *Michigan Register* can be viewed free of charge on the Internet web site of the State Office of Administrative Hearings and Rules: www.michigan.gov/cis/0,1607,7-154-10576_35738---,00.html

Issue 2000-3 and all subsequent editions of the *Michigan Register* can be viewed on the State Office of Administrative Hearings and Rules Internet web site. The electronic version of the *Register* can be navigated using the blue highlighted links found in the Contents section. Clicking on a highlighted title will take the reader to related text, clicking on a highlighted header above the text will return the reader to the Contents section.

Peter Plummer, Executive Director
State Office of Administrative Hearings and Rules

2009 PUBLICATION SCHEDULE

Issue No.	Closing Date for Filing or Submission Of Documents (5 p.m.)	Publication Date
1	January 15, 2009	February 1, 2009
2	February 1, 2009	February 15, 2009
3	February 15, 2009	March 1, 2009
4	March 1, 2009	March 15, 2009
5	March 15, 2009	April 1, 2009
6	April 1, 2009	April 15, 2009
7	April 15, 2009	May 1, 2009
8	May 1, 2009	May 15, 2009
9	May 15, 2009	June 1, 2009
10	June 1, 2009	June 15, 2009
11	June 15, 2009	July 1, 2009
12	July 1, 2009	July 15, 2009
13	July 15, 2009	August 1, 2009
14	August 1, 2009	August 15, 2009
15	August 15, 2009	September 1, 2009
16	September 1, 2009	September 15, 2009
17	September 15, 2009	October 1, 2009
18	October 1, 2009	October 15, 2009
19	October 15, 2009	November 1, 2009
20	November 1, 2009	November 15, 2009
21	November 15, 2009	December 1, 2009
22	December 1, 2009	December 15, 2009
23	December 15, 2009	January 1, 2010
24	January 1, 2010	January 15, 2010

CONTENTS

ADMINISTRATIVE RULES FILED WITH SECRETARY OF STATE

Department of Energy, Labor & Economic Growth

Bureau of Fire Services (SOAHR # 2007-063)

Fire Inspector Certification2-7

Department of Energy, Labor & Economic Growth

State office of Administrative Hearings and Rules (SOAHR # 2008-047)

State Police Retirement Board – General Hearing Rules8-11

PROPOSED ADMINISTRATIVE RULES, NOTICES OF PUBLIC HEARINGS

Department of Energy, Labor & Economic Growth

State office of Administrative Hearings and Rules (SOAHR # 2008-046)

State Retirement Board – General Hearing Rules 13-19

Department of Energy, Labor & Economic Growth

Director’s Office (SOAHR # 2009-018)

Part 381 Ionizing Radiation20-41

ENROLLED SENATE AND HOUSE BILLS SIGNED INTO LAW OR VETOED

Table (2009 Session)43-50

MICHIGAN ADMINISTRATIVE CODE TABLE

Table (2009 Session)52-55

CUMULATIVE INDEX

Cumulative Index (2009)56-59

**ADMINISTRATIVE RULES
FILED WITH THE SECRETARY OF STATE**

MCL 24.208 states in part:

“Sec. 8. (1) The State Office of Administrative Hearings and Rules shall publish the Michigan register at least once each month. The Michigan register shall contain all of the following:

** * **

(f) Administrative rules filed with the secretary of state.”

ADMINISTRATIVE RULES

SOAHR 2007-063

DEPARTMENT OF ENERGY, LABOR & ECONOMIC GROWTH

BUREAU OF FIRE SERVICES

FIRE INSPECTOR CERTIFICATION

Filed with the Secretary of State on June 12, 2009

These rules become effective 60 days after filing.

(By authority conferred on the bureau of fire services by sections 1c, 2b, 3c, and 3 e of 1941 PA 207, MCL 29.1c, 29.2b, 29.3c and 29.3e)

R 29.501, R 29.502, R 29.503, R 29.504, R 29.505, R 29.506, R 29.507, and R 29.508 are amended, and R 29.501a, R 29.502a, R 29.502b, R 29.506a, and R 29.507a are added to the Michigan administrative code as follows:

R 29.501 Definitions.

Rule 1. (1) As used in these rules, "act" means 1941 PA 207, MCL 29.1 to 29.34.

(2) "Continuing education point" means 1 hour spent in training toward continuing education requirements, excluding time spent for lunches, breaks, or other non-training functions.

R 29.501a Adoption by reference.

Rule 1a. (1) The requirements for fire inspector I certification as provided in NFPA 1031 standard for professional qualifications for fire inspector and plan examiner 2003 edition, effective August 7, 2003, are adopted by reference in these rules.

(2) Copies of the standard are available for purchase and download from the NFPA (national fire protection association) at a price at the time of the adoption of these rules of \$34.50. A copy may be ordered online from the NFPA at nfpa.org. Copies of the standard are also available for review from the bureau of fire services, FOIA Coordinator, P.O. Box 30700, Lansing MI 48913, telephone (517) 241-8847. Copies may be purchased from the bureau at the same cost as copyrighted materials from the NFPA plus \$25 for the cost of shipping and handling.

R 29.502 Certification requirements.

Rule 2. To qualify for certification as a certified fire inspector, an applicant shall have met all of the following requirements:

- (a) Be at least 18 years of age.
- (b) Have graduated from an accredited high school or have received a general education development test certificate from the department of education.
- (c) Be able to read and write English.

(d) Be of good moral character. For purposes of these rules a conviction of a misdemeanor or felony which involves theft, dishonesty, or false statement shall be considered as an indication that a person is not likely to serve in a fair, honest, and open manner.

(e) Have not been convicted of any misdemeanor or felony reasonably related to the person's ability to perform as a fire inspector.

(f) Achieve a score of 75% or better on each examination described in R 29.503.

(g) Maintain employment by a governmental agency as a fire inspector supervisor or a fire inspector conducting fire inspections for not less than 4 hours per week.

(h) Hold an NFPA fire inspector I certification, or the equivalent, as determined by the bureau of fire services in consultation with the state fire safety board.

R 29.502a Recertification.

Rule 2a. To be recertified as a state-certified fire inspector, an applicant shall do 1 of the following as appropriate:

(a) Maintain current certification in accordance with both of the following:

(i) Meet the NFPA Inspector 1 requirements as adopted in R 29.501a, former Michigan state police fire inspector training, or other approved program.

(ii) Comply with continuing education as required in R 29.506.

(b) If any applicant's certification has lapsed for not more than the 6 years, the inspector is considered inactive. To be recertified, the applicant shall complete all continuing education points as required in R 19.506 since expiration date of the certification and not later than 90 days following submission of the recertification application to the bureau of fire services.

(c) If a state-certified fire inspector certification has lapsed for more than 6 years, the applicant shall comply with the certification requirements of R 29.502.

R 29.502b Certification denial; revocation.

Rule 2b. A state-certified fire inspector shall be subject to denial or revocation of certification for any of the following actions:

(a) Upon request by resolution of a governing body of an organized fire department in accordance with MCL 29.2b (3).

(b) False registration of attendance at any approved certification program.

(c) Conviction of a misdemeanor or felony reasonably related to the person's ability to perform as a fire inspector.

(d) Failure to report all post-certification misdemeanors or felonies to the bureau of fire services, as required by R 29.505.

(e) Falsification of any certified fire inspector documentation.

(f) Noncompliance with recertification requirements.

R 29.502c Appeals process for revocation.

Rule 2c. If certification is revoked, then the bureau of fire services shall notify the affected party and provide an explanation for the revocation. Applicants may appeal in writing to the state fire marshal for a redetermination within 14 business days of the notification date. Decisions of the state fire marshal may be appealed to the state fire safety board. The direct gubernatorial appointees of the fire safety board may conduct a hearing or refer the matter to the state office of administrative hearings and rules for a hearing pursuant to the administrative procedures act, 1969 PA 306, MCL 24.271 to 24.327.

R 29.502d Review process for denial.

Rule 2d. If certification is denied, then the bureau of fire services shall notify the affected party and provide an explanation for the denial. Applicants may submit a written request to the state fire marshal for a review within 14 business days of the notification date. Decisions of the state fire marshal may be reviewed by the state fire safety board upon a request for the review by the affected party or parties.

R 29.503 Fire inspectors training course and examination; application; selection of applicants for course; course curriculum; preparation of examination; content of examination.

Rule 3. (1) A person who desires to participate in the fire inspectors training in subrule (2) of this rule or who desires to take the examination offered in subrule (4) of this rule shall apply on a form prescribed and furnished by the bureau of fire services. The application shall state whether the person desires to participate in the fire inspectors training class or take the examination without participating in the class. Persons who do not participate in the class but who desire to take the examination shall be provided a course outline and a list of resource material on which the examination is based. Applications shall be received not less than 60 days before the start of the class or, if no class is scheduled, 60 days before the date of the examination.

(2) The state fire marshal shall determine which persons shall attend a fire inspector training course. A person denied the opportunity to attend may request a review of that denial to the state fire safety board pursuant to section 3c of the act.

(3) The course in subrule (2) of this rule shall conform to a curriculum approved by the state fire safety board.

(4) Examinations shall be approved by the state fire safety board. The examinations may be given in parts and in total shall consist of not less than all of the following categories:

- (a) Characteristics and behavior of fire.
- (b) Fire safety in building design and construction.
- (c) The hazards of occupancies.
- (d) Water supplies for fire protection.
- (e) Fire alarm systems and detection devices.
- (f) Extinguishing agents.
- (g) Water sprinkler systems.
- (h) Special fire protection systems.
- (i) Portable fire extinguishers.
- (j) Fire hazards of materials.
- (k) Fire investigation.
- (l) Hazardous materials.
- (m) Plan and review of blueprints.
- (n) Regulations and administrative rules pertaining to fire prevention and safety.

R 29.504 Examination; failure to achieve passing score; reexamination.

Rule 4. (1) A person who does not achieve a score of 75% or better on each part of the examination on his or her first testing may retake that part of the examination at the next regularly scheduled examination date.

(2) A person who does not achieve a score of 75% or better on each part of the examination upon which the person was reexamined on his or her second testing may retake that part of the examination only after the person attends the applicable part of the course described in R 29.503 or receives training which the state fire safety board determines equivalent.

(3) A person who does not achieve a score of 75% or better on each part of the examination upon which the person was reexamined on his or her third testing may retake that part of the examination only after waiting 2 years after the date of the third testing.

R 29.505 State-certified fire inspector; recordkeeping; responsibility.

Rule 5. A state-certified fire inspector shall do the following:

- (a) Keep track of his or her continuing education points on a form prescribed and furnished by the bureau of fire services.
- (b) Furnish documentation of education, experience, and training upon request of the bureau of fire services.
- (c) Complete and submit an application for recertification to the bureau of fire services along with evidence of continuing education not already reviewed by the bureau of fire services at the end of the 3-year certification period.
- (d) Report all misdemeanor and felony convictions to the bureau of fire services upon conviction.

R 29.506 Continuing education.

Rule 6. (1) Continuing education shall conform to the curriculum established by the fire fighters training council, and be approved by the state fire safety board, and consist of at least 1 of the following categories:

- (a) Inspection practices and principles.
 - (b) Fire safety in building design and construction.
 - (c) Occupancies classifications and hazards.
 - (d) Water supplies for fire protection.
 - (e) Fire alarm systems.
 - (f) Extinguishing agents.
 - (g) Automatic sprinkler systems.
 - (h) Alternative fire protection (suppression) systems.
 - (i) Standpipe systems.
 - (j) Portable fire extinguishers.
 - (k) Fire hazards of materials.
 - (l) Fire investigation.
 - (m) Hazardous materials.
 - (n) Plan review.
 - (o) Legal aspects, including state laws and administrative rules pertaining to fire prevention and safety.
 - (p) Communication (written and verbal).
 - (q) Public fire education.
 - (r) Fire and life safety codes or standards.
 - (s) Personal and professional development.
 - (t) Homeland security.
- (2) Certified inspectors shall complete a minimum of 10 continuing education points per year and not less than 60 points in a 3-year recertification period.
- (3) Distance learning courses may be accepted for continuing education points, provided they meet all the following requirements:
- (a) Not more than 30 points shall be earned in a 3-year certification period for distances courses.
 - (b) Courses shall be interactive or self-paced.
 - (c) Each course shall use a clearly defined syllabus to show the approximate time spent on each topic covered in the course.
 - (d) Program applications shall be accompanied by procedures which outline how the criteria in this subrule have been met.
 - (e) A certificate of completion or roster signed by the instructor shall be provided to bureau of fire services and shall include the course approval number.

Rule 29. 506a Program approval.

Rule 6a. All state-certified fire inspector continuing education programs shall be preapproved by the bureau of fire services before continuing education points are awarded. Program approval depends upon the following criteria:

- (a) Requests shall be submitted to the bureau at least 60 days before the training.
- (b) The sponsoring agency or instructor shall submit a completed certified fire inspector continuing education program approval application to the bureau.
- (c) Each program shall include a program roster or other approved means for reporting the student attendance.
- (d) Distance learning course providers shall submit a certificate of completion or transcript to the student.
- (e) Rosters, certificates of completion, or transcripts shall include all of the following:
 - (i) Program specific information.
 - (ii) Signature or name of each student, as applicable.
 - (iii) Certificate number of each student.
 - (iv) Signature or name of instructor of record, as applicable.
- (f) Approved alternative program attendance rosters or systems shall include all information found on the program roster.
- (g) Rosters or transcripts shall be submitted by the course provider within 10 days of the completion of the course to the bureau of fire services for auditing purposes. Students shall submit copies of their certificates of completion to the bureau within 10 days of the completion of the course.
- (h) The training instructor/sponsoring agency shall provide prospective students with the bureau of fire services program training approval number and the points awarded for successful completion.
- (i) Each training program may be approved for not more than a 3-year period and shall correspond to the current fire inspector certification.
- (j) If a program sponsor or instructor refuses or fails to submit information for course approval, an individual may submit information meeting the criteria in subdivision (a), (b), (c) or (d), and (e) of this subrule, as well as documentation of efforts to have the sponsor apply directly.
- (k) A program approved in the middle of a current 3-year cycle shall expire at the end of that cycle.

R 29.507 Delegation of authority

Rule 7 (1) An organized fire department or governing body seeking endorsement for delegation of authority shall submit a request for delegation of authority in the form of a resolution from the governing body to the bureau of fire services.

- (2) Candidates to whom authority may be delegated shall meet all of the following:
 - (a) Hold current certification as a state-certified fire inspector.
 - (b) Successfully complete in-house training developed and conducted by the bureau of fire services.
 - (c) Complete continuing education in accordance with R 29.506.
 - (d) Be employed as a full-time fire inspector.
- (3) Delegation of authority is subject to approval by the bureau of fire services and shall be granted for not more than 2 years beginning each January of an even year and ends the last day of December of the odd year.

R 29.507a Issuance of fire inspector certification; issuance of credentials verifying delegation of authority.

Rule 7a. (1) The state fire marshal shall certify or recertify a person who meets the requirements as a certified fire inspector pursuant to section 2b of the act and R 29.502 and R 29.502a under the following circumstances:

(a) Certification shall be granted for a period of not more than 3 years.

(b) Certification shall expire on December 31 of the year following adoption of these rules and every 3 years thereafter.

(c) As a condition of recertification, a certified inspector shall complete the minimum continuing education requirements established in R29.506.

(d) The bureau of fire services shall issue credentials to a person to whom authority is delegated pursuant to section 2b of the act and R 29.507.

(2) At the time of certification and recertification the bureau of fire services shall issue a card to each state-certified fire inspector employed by an organized fire department or authorized governing body which is approved for delegation for not more than 2 years.

R 29.508 Bureau of fire services; responsibilities.

Rule 8. (1) The bureau of fire services shall maintain a file of those persons who have been certified and shall review certification at least every 3 years for compliance with the act and rules promulgated pursuant to the act.

(2) The bureau of fire services shall maintain a file of those persons delegated authority pursuant to section 2b of the act and shall review the delegation at least every 2 years for compliance with the act and rules promulgated pursuant to the act.

ADMINISTRATIVE RULES

SOAHR 2008-047 SR

DEPARTMENT OF ENERGY, LABOR, AND ECONOMIC GROWTH

STATE OFFICE OF ADMINISTRATIVE HEARINGS AND RULES

STATE POLICE RETIREMENT BOARD - GENERAL HEARING RULES

Filed with the Secretary of State on June 12, 2009

These rules become effective immediately upon filing with the Secretary of State unless adopted under sections 33, 44, or 45a(6) of 1969 PA 306. Rules adopted under these sections become effective 7 days after filing with the Secretary of State.

(By authority conferred on the State Office of Administrative Hearings and Rules by Executive Order 2005-1, MCL 445.2021.)

R 38.1671, R 38.1672, R 38.1673, R 38.1674, R 38.1675, R 38.1676, R 38.1677, R 38.1678, R 38.1679, R 38.1680, R 38.1681, R 38.1682, R 38.1683, R 38.1684, R 38.1685, and R 38.1686 are added to the Michigan Administrative Code as follows:

PART I. PROCEDURAL RULES

R 38.1671 Applicability and definitions.

Rule 71. (1) These rules apply to hearings held under the jurisdiction of the state police retirement board.

(2) As used in these rules:

(a) “Act” means the state police retirement act of 1986, 1986 PA 182, MCL 38.1601.

(b) “Administrative record” means the application and related documents considered by the staff of the retirement system in reaching its determination.

(c) “Application” means a request for a benefit provided by the act. “Application” also includes a request to reopen a closed application and a reapplication.

(d) “Board” means the retirement board as defined in MCL 38.1606.

(e) “Closed application” means a request by an individual for a benefit provided by the act that was withdrawn by the individual or otherwise never decided by the retirement system or the board.

(f) “Good cause,” as used in R 38.1674 and R 38.1682(2), means the legitimate failure to file a document or a witness list in a timely manner and does not include a person’s own careless neglect or inattention to the requirements of R 38.1674 and R 38.1682(2).

(g) “Presiding officer” means presiding officer as defined in MCL 24.279 and 24.280.

(h) “Reapplication” means a request by an individual for a benefit provided by the act that was previously decided by the staff of the retirement system or the board.

(3) The terms defined in 1986 PA 182, MCL 38.1601 et seq; and 1969 PA 306, MCL 24.201 et seq; have the same meaning when used in these rules.

R 38.1672 Notice of hearing.

Rule 72. Notification of any hearing shall state the date, time, place, and issues involved. Notice shall be mailed by first-class mail at least 35 days before the hearing.

R 38.1673 Appearance.

Rule 73. (1) If a party is represented by an attorney, the attorney shall file a written appearance.

(2) An appearance made at a hearing shall be made in person either by the individual who requested the hearing or by legal counsel.

R 38.1674 Filing of documents.

Rule 74. If a document is not filed and served within the time limits established by these rules, the presiding officer or the board shall strike the document unless the individual serving the document establishes good cause as to why the document was not filed and served timely.

R 38.1675 Service.

Rule 75. (1) A party shall serve all documents filed in a contested case on all other parties and the presiding officer. Service shall be made in person or by first-class mail with postage fully paid and addressed to the individual to be served at the individual's last known address.

(2) The date of service shall be the date of personal service or the date that the document is placed in first-class mail.

(3) A party who files a document in a contested case hearing shall file a proof of service that establishes the document was simultaneously and properly served on all other parties.

R 38.1676 Pre-hearing conference; scope.

Rule 76. (1) If a presiding officer determines that a pre-hearing conference will aid in the efficient resolution of the contested case, the presiding officer may direct the parties or their attorneys to participate in a pre-hearing conference, either in person or by telephone, to do any of the following:

- (a) State and simplify the factual and legal issues involved.
- (b) Consider motions to be disposed of before hearing and other preliminary matters.
- (c) Identify proposed documentary evidence and determine its authenticity, if possible.
- (d) Estimate the time for hearing.
- (e) Consider other matters that may aid in the resolution of the contested case.

(2) The presiding officer may provide a written summary of the items discussed to each party after the pre-hearing conference.

(3) At a pre-hearing conference, the presiding officer may direct the parties to file a hearing brief as to any of the issues involved in the action. If the parties are directed to submit hearing briefs, then the parties shall submit briefs to the presiding officer not less than 10 days before the hearing, unless a different date is set by the presiding officer.

R 38.1677 Presiding officer.

Rule 77. (1) The state office of administrative hearings and rules shall designate presiding officers in contested case proceedings.

(2) A presiding officer shall issue orders that are necessary for the fair and efficient determination of the issues presented. These include, but are not limited to, an order in response to a motion to do any of the following:

- (a) Extend the time to file a closing argument.
- (b) Extend the time to file exceptions and/or replies.
- (c) Adjourn a hearing.

- (3) A party shall comply with an order of a presiding officer.
- (4) Neither the presiding officer nor any attorney in a contested case may issue a subpoena.

R 38.1678 Adjournment or continuance of hearing.

Rule 78. A hearing shall not be adjourned or continued except upon an order of the presiding officer. Unless made during a hearing, all motions and requests for an adjournment, or a continuance, shall be filed in writing and state concisely the reasons why an adjournment or continuance is necessary.

R 38.1679 Hearing record.

Rule 79. A verbatim record shall be made of each hearing held. Upon request, a party may order a transcript. The requestor shall pay the cost of the transcript.

R 38.1680 Form; time for filing motion.

Rule 80. (1) A request to the presiding officer for an order in a pending action shall be by motion, in writing, unless made during a hearing. The request shall state the relief or order sought, the grounds and authority on which the request is based, and be signed by the party or the party's attorney.

(2) A copy of the written motion and brief, if any, shall be served in accordance with R 38.1675(1). If a motion or response is supported by affidavit, then the affidavit shall be filed and served with the motion or response.

(3) A party opposing a motion shall serve a response and any brief and supporting affidavit or affidavits within 14 days after service of the motion unless otherwise ordered by the presiding officer.

(4) The presiding officer may limit or dispense with oral arguments on motions.

R 38.1681 Motion for summary disposition.

Rule 81. (1) A party may move for summary disposition on all or any part of the claim at any time. The motion shall state that the moving party is entitled to summary disposition on 1 or more of the following grounds and shall specify the grounds on which the motion is based:

- (a) The petitioner has failed to state a claim upon which relief can be granted.
- (b) There is no genuine issue as to a material fact, except as to the relief to be granted.
- (c) The board lacks jurisdiction of the subject matter.
- (d) The claim or defense is barred because it is untimely.
- (e) The claim or defense is barred because of some other legal impediment or other disposition of the claim.

(2) If the motion for summary disposition is based on subrule (1)(a) of this rule, then only pleadings may be considered. A motion based on subrule (1)(b), (c), (d) or (e) of this rule shall be supported by affidavits or other documentary evidence and shall specifically identify the issues on which the moving party believes there is no genuine issue of material fact. The affidavits, together with the pleadings and documentary evidence then filed in the action, or submitted by the parties, shall be considered. If a motion is made under subrule (1)(b) of this rule and supported as provided in this rule, then an adverse party shall, by affidavits or otherwise provided in this rule, set forth specific facts showing that there is a genuine issue for hearing.

(3) A presiding officer shall rule on a motion for summary disposition in a proposal for decision.

R 38.1682 Discovery.

Rule 82. (1) Discovery shall not be allowed in any contested case hearing conducted under the act or these rules except depositions may be taken upon written approval of the board where it is established that it is impractical or impossible to otherwise obtain the evidence. If the board approves the taking of a deposition, it shall be taken in conformity with the Michigan court rules.

(2) The petitioner shall serve a list of witnesses 20 days before the scheduled hearing date. If the petitioner wishes to testify, he or she shall be included in the witness list. The respondent shall serve a list of witnesses 10 days before the scheduled hearing date. A party shall not call as a witness a person who was not included on a witness list unless the presiding officer finds that the party has established good cause as to why the person was not included on the party's witness list.

R 38.1683 Closing arguments.

Rule 83. The presiding officer shall notify the parties whether written or oral closing arguments shall be scheduled and the time deadlines for such arguments.

R 38.1684 Proposal for decision.

Rule 84. The presiding officer shall prepare a proposal for decision within a reasonable time after the closing of the record. It shall include findings of fact, conclusions of law, and a recommended decision. The proposal for decision shall be served on each of the parties and the hearing coordinator of the retirement system.

R 38.1685 Considerations of documents.

Rule 85. (1) Any documents submitted by or on behalf of the applicant more than 30 days after the date of the notification set forth in R 38.1672 shall not be considered except upon a showing of good cause.

(2) The presiding officer shall admit the administrative record if offered into evidence at the hearing.

R 38.1686 Testimony; telephone and other electronic means.

Rule 86. A presiding officer shall not take the testimony of a witness by way of a telephone conference call or other electronic means unless all of the following occur:

(a) The party who wants to take such testimony serves a motion at least 10 days before the date of the hearing.

(b) The presiding officer concludes that it is impractical or impossible to otherwise obtain the testimony.

(c) The presiding officer concludes that the witness is not needed to appear in person so that the witness's appearance and demeanor may be observed for credibility purposes.

**PROPOSED ADMINISTRATIVE RULES,
NOTICES OF PUBLIC HEARINGS**

MCL 24.242(3) states in part:

“... the agency shall submit a copy of the notice of public hearing to the State Office of Administrative Hearings and Rules for publication in the Michigan register. An agency's notice shall be published in the Michigan register before the public hearing and the agency shall file a copy of the notice of public hearing with the State Office of Administrative Hearings and Rules.”

MCL 24.208 states in part:

“Sec. 8. (1) The State Office of Administrative Hearings and Rules shall publish the Michigan register at least once each month. The Michigan register shall contain all of the following:

* * *

(d) Proposed administrative rules.

(e) Notices of public hearings on proposed administrative rules.”

PROPOSED ADMINISTRATIVE RULES

SOARH 2008-046

DEPARTMENT OF ENERGY, LABOR, AND ECONOMIC GROWTH

STATE OFFICE OF ADMINISTRATIVE HEARINGS AND RULES

JUDGES RETIREMENT BOARD - GENERAL HEARING RULES

Filed with the Secretary of State on

These rules become effective immediately upon filing with the Secretary of State unless adopted under sections 33, 44, or 45a(6) of 1969 PA 306. Rules adopted under these sections become effective 7 days after filing with the Secretary of State.

(By authority conferred on the State Office of Administrative Hearings and Rules by Executive Order 2005-1, MCL 445.2021.)

Draft April 10, 2009

R 38.801, R 38.802, R 38.803, R 38.804, R 38.805, R 38.806, R 38.807, and R 38.808 of the Michigan Administrative Code are rescinded, and R 38.2171, R 38.2172, R 38.2173, R 38.2174, R 38.2175, R 38.2176, R 38.2177, R 38.2178, R 38.2179, R 38.2180, R 38.2181, R 38.2182, R 38.2183, R 38.2184, R 38.2185, and R 38.2186 are added to the Code as follows:

PART I. PROCEDURAL RULES

R 38.801 ~~Notice of hearing.~~ **Rescinded.**

~~Rule 1. Notification of any hearing before the judges' retirement board will be by registered mail, and will state the date, time, place, issues involved, and reasons for holding said hearing. Such notice will be mailed at least 10 days prior to said hearing. Unless indicated otherwise, all hearings will be held in the offices of the judges' retirement board.~~

R 38.802 ~~Appearance.~~ **Rescinded.**

~~Rule 2. When an appearance is made at a hearing, it shall be made either in person or by a duly authorized representative, or by counsel.~~

R 38.803 ~~Written answer; oral statement on charges; service of briefs or arguments.~~ **Rescinded.**

~~Rule 3. The person or persons who have been served with a notice of hearing may, at his option, file a written answer thereto prior to the date set for hearing, or at said hearing may appear and present an oral statement on the charges contained in the notice of hearing. When written briefs or arguments are presented, a copy shall be served upon the opposite parties or their attorneys at least 10 days prior to the date set for the hearing.~~

R 38.804 ~~Failure to appear.~~ **Rescinded.**

~~Rule 4. If the person or persons who have been previously served with a notice of hearing fail to appear at a noticed hearing, the judges' retirement board may proceed with a hearing of the cases brought before it, and may, on the evidence presented, make its decision.~~

R 38.805 Statement of facts. Rescinded.

~~Rule 5. When a hearing is requested, the party requesting the hearing shall submit in writing a fair and accurate statement of the facts to the judges' retirement board and all interested parties. The facts shall be accepted as evidence unless a written answer is filed denying said facts and stating new facts relied upon with the judges' retirement board and all interested parties.~~

R 38.806 Adjournment or continuance of hearing. Rescinded.

~~Rule 6. No hearing shall be adjourned or continued except upon an order of the judges' retirement board or the department employee conducting the hearing. All motions and requests for an adjournment, or a continuance, shall be in writing, which instrument shall state concisely the reasons why an adjournment or continuance is necessary. No motion or request for an adjournment or continuance will be considered unless the same is filed with the judges' retirement board at least 5 days prior to the date assigned for the hearing of the application, complaint or petition, except upon order of the executive secretary of the retirement board which exception will be granted only upon a showing that for reasons not within the control of the person or party making the motion or request, the motion or request could not be filed within the time limited.~~

R 38.807 Stipulations. Rescinded.

~~Rule 7. The parties to any hearing before the judges' retirement board may, by a stipulation in writing, filed with the judges' retirement board, agree upon the facts or any portion of the facts involved in the controversy, which stipulation shall be regarded and used as evidence on the hearing. Parties are requested to thus agree upon the facts whenever practicable.~~

R 38.808 Depositions. Rescinded.

~~Rule 8. Depositions shall only be taken upon written authority of the judges' retirement board where it is proved in writing to the judges' retirement board that it is impractical or impossible to otherwise obtain the evidence. Where depositions are permitted, they shall be taken according to the rules for taking depositions in civil cases in the state of Michigan, being Michigan Statutes Annotated, S27.854 et seq., with all parties given an opportunity to cross-examine the witness under oath.~~

R 38.2171 Applicability and definitions.

Rule 71. (1) These rules apply to hearings held under the jurisdiction of the judges retirement board.

(2) As used in these rules:

- (a) "Act" means the judges retirement act of 1992, 1992 PA 234, MCL 38.2101.**
- (b) "Administrative record" means the application and related documents considered by the staff of the retirement system in reaching its determination.**
- (c) "Application" means a request for a benefit provided by the act. "Application" also includes a request to reopen a closed application and a reapplication.**
- (d) "Board" means the retirement board as defined in MCL 38.2202.**

(e) “Closed application” means a request by an individual for a benefit provided by the act that was withdrawn by the individual or otherwise never decided by the retirement system or the board.

(f) “Good cause,” as used in R 38.2174 and R 38.2182(2), means the legitimate failure to file a document or a witness list in a timely manner and does not include a person’s own careless neglect or inattention to the requirements of R 38.2174 and R 38.2182(2).

(g) “Presiding officer” means presiding officer as defined in MCL 24.279 and 24.280.

(h) “Reapplication” means a request by an individual for a benefit provided by the act that was previously decided by the staff of the retirement system or the board.

(3) The terms defined in 1992 PA 234, MCL 38.2101 et seq; and 1969 PA 306, MCL 24.201 et seq; have the same meaning when used in these rules.

R 38.2172 Notice of hearing.

Rule 72. Notification of any hearing shall state the date, time, place, and issues involved. Notice shall be mailed by first-class mail at least 35 days before the hearing.

R 38.2173 Appearance.

Rule 73. (1) If a party is represented by an attorney, the attorney shall file a written appearance.

(2) An appearance made at a hearing shall be made in person either by the individual who requested the hearing or by legal counsel.

R 38.2174 Filing of documents.

Rule 74. If a document is not filed and served within the time limits established by these rules, the presiding officer or the board shall strike the document unless the individual serving the document establishes good cause as to why the document was not filed and served timely.

R 38.2175 Service.

Rule 75. (1) A party shall serve all documents filed in a contested case on all other parties and the presiding officer. Service shall be made in person or by first-class mail with postage fully paid and addressed to the individual to be served at the individual’s last known address.

(2) The date of service shall be the date of personal service or the date that the document is placed in first-class mail.

(3) A party who files a document in a contested case hearing shall file a proof of service that establishes the document was simultaneously and properly served on all other parties.

R 38.2176 Pre-hearing conference; scope.

Rule 76. (1) If a presiding officer determines that a pre-hearing conference will aid in the efficient resolution of the contested case, the presiding officer may direct the parties or their attorneys to participate in a pre-hearing conference, either in person or by telephone, to do any of the following:

- (a)** State and simplify the factual and legal issues involved.
- (b)** Consider motions to be disposed of before hearing and other preliminary matters.
- (c)** Identify proposed documentary evidence and determine its authenticity, if possible.
- (d)** Estimate the time for hearing.
- (e)** Consider other matters that may aid in the resolution of the contested case.

(2) The presiding officer may provide a written summary of the items discussed to each party after the pre-hearing conference.

(3) At a pre-hearing conference, the presiding officer may direct the parties to file a hearing brief as to any of the issues involved in the action. If the parties are directed to submit hearing briefs, then the parties shall submit briefs to the presiding officer not less than 10 days before the hearing, unless a different date is set by the presiding officer.

R 38.2177 Presiding officer.

Rule 77. (1) The state office of administrative hearings and rules shall designate presiding officers in contested case proceedings.

(2) A presiding officer shall issue orders that are necessary for the fair and efficient determination of the issues presented. These include, but are not limited to, an order in response to a motion to do any of the following:

- (a) Extend the time to file a closing argument.
- (b) Extend the time to file exceptions and/or replies.
- (c) Adjourn a hearing.
- (3) A party shall comply with an order of a presiding officer.
- (4) Neither the presiding officer nor any attorney in a contested case may issue a subpoena.

R 38.2178 Adjournment or continuance of hearing.

Rule 78. A hearing shall not be adjourned or continued except upon an order of the presiding officer. Unless made during a hearing, all motions and requests for an adjournment, or a continuance, shall be filed in writing and state concisely the reasons why an adjournment or continuance is necessary.

R 38.2179 Hearing record.

Rule 79. A verbatim record shall be made of each hearing held. Upon request, a party may order a transcript. The requestor shall pay the cost of the transcript.

R 38.2180 Form; time for filing motion.

Rule 80. (1) A request to the presiding officer for an order in a pending action shall be by motion, in writing, unless made during a hearing. The request shall state the relief or order sought, the grounds and authority on which the request is based, and be signed by the party or the party's attorney.

(2) A copy of the written motion and brief, if any, shall be served in accordance with R 38.2175(1). If a motion or response is supported by affidavit, then the affidavit shall be filed and served with the motion or response.

(3) A party opposing a motion shall serve a response and any brief and supporting affidavit or affidavits within 14 days after service of the motion unless otherwise ordered by the presiding officer.

(4) The presiding officer may limit or dispense with oral arguments on motions.

R 38.2181 Motion for summary disposition.

Rule 81. (1) A party may move for summary disposition on all or any part of the claim at any time. The motion shall state that the moving party is entitled to summary disposition on 1 or more of the following grounds and shall specify the grounds on which the motion is based:

- (a) The petitioner has failed to state a claim upon which relief can be granted.

- (b) There is no genuine issue as to a material fact, except as to the relief to be granted.
- (c) The board lacks jurisdiction of the subject matter.
- (d) The claim or defense is barred because it is untimely.
- (e) The claim or defense is barred because of some other legal impediment or other disposition of the claim.

(2) If the motion for summary disposition is based on subrule (1)(a) of this rule, then only pleadings may be considered. A motion based on subrule (1)(b), (c), (d) or (e) of this rule shall be supported by affidavits or other documentary evidence and shall specifically identify the issues on which the moving party believes there is no genuine issue of material fact. The affidavits, together with the pleadings and documentary evidence then filed in the action, or submitted by the parties, shall be considered. If a motion is made under subrule (1)(b) of this rule and supported as provided in this rule, then an adverse party shall, by affidavits or otherwise provided in this rule, set forth specific facts showing that there is a genuine issue for hearing.

(3) A presiding officer shall rule on a motion for summary disposition in a proposal for decision.

R 38.2182 Discovery.

Rule 82. (1) Discovery shall not be allowed in any contested case hearing conducted under the act or these rules except depositions may be taken upon written approval of the board where it is established that it is impractical or impossible to otherwise obtain the evidence. If the board approves the taking of a deposition, it shall be taken in conformity with the Michigan court rules.

(2) The petitioner shall serve a list of witnesses 20 days before the scheduled hearing date. If the petitioner wishes to testify, he or she shall be included in the witness list. The respondent shall serve a list of witnesses 10 days before the scheduled hearing date. A party shall not call as a witness a person who was not included on a witness list unless the presiding officer finds that the party has established good cause as to why the person was not included on the party's witness list.

R 38.2183 Closing arguments.

Rule 83. The presiding officer shall notify the parties whether written or oral closing arguments shall be scheduled and the time deadlines for such arguments.

R 38.2184 Proposal for decision.

Rule 84. The presiding officer shall prepare a proposal for decision within a reasonable time after the closing of the record. It shall include findings of fact, conclusions of law, and a recommended decision. The proposal for decision shall be served on each of the parties and the hearing coordinator of the retirement system.

R 38.2185 Considerations of documents.

Rule 85. (1) Any documents submitted by or on behalf of the applicant more than 30 days after the date of the notification set forth in R 38.2172 shall not be considered except upon a showing of good cause.

(2) The presiding officer shall admit the administrative record if offered into evidence at the hearing.

R 38.2186 Testimony; telephone and other electronic means.

Rule 86. A presiding officer shall not take the testimony of a witness by way of a telephone conference call or other electronic means unless all of the following occur:

- (a) The party who wants to take such testimony serves a motion at least 10 days before the date of the hearing.**
- (b) The presiding officer concludes that it is impractical or impossible to otherwise obtain the testimony.**
- (c) The presiding officer concludes that the witness is not needed to appear in person so that the witness's appearance and demeanor may be observed for credibility purposes.**

NOTICE OF PUBLIC HEARING

SOAHR #: 2008-046
NOTICE OF PUBLIC HEARING

The Department of Management and Budget, Office of Retirement Services and the Department of Energy, Labor and Economic Growth, State Office of Administrative Hearings and Rules

The Judges Retirement Board and the State Office of Administrative Hearings and Rules will hold a public hearing on July 23, 2009 at 2:00 p.m. The hearing will be held in Conference Room A, 1st Floor of the General Office Building, 7150 Harris Drive, Dimondale, Michigan.

The public hearing is being held to receive comments from interested persons on the promulgation of General Rules: Adding R 38.2171-R38.2186, and Rescission of R 38.801-R38.808.

The Rules for the State Office of Administrative Hearings and Rules are being promulgated under the authority of Executive Order 2005-1, MCL 445.2021. It is proposed that all of the Rules will take effect immediately after filing with the Secretary of State.

Comments may be presented in person and in writing at the time of the hearing. Comments may also be submitted by mail or FAX until July 23, 2009 at 5:00 p.m. Address any comments to:

Judges Retirement Board
Attention: Executive Secretary to the Board
P.O. Box 31070
Lansing, Michigan 48909
Or FAX: 517-322-6145

All hearings are conducted in compliance with the 1900 Americans with Disabilities Act. Hearings are held in buildings that accommodate mobility impaired individuals and accessible parking is available. A disabled person who requires accommodations for effective participation in a hearing should call Linda Albro Sparks at 517-636-6039 (voice) to make the necessary arrangements. To ensure availability of the accommodation, please call at least one (1) week in advance.

Date: May 18, 2009

SOAHR #: 2008-046 SR

PROPOSED ADMINISTRATIVE RULES

SOAHR 2009-018

DEPARTMENT OF ENERGY, LABOR & ECONOMIC GROWTH

DIRECTOR'S OFFICE

OCCUPATIONAL HEALTH STANDARDS

Filed with the Secretary of State on

These rules become effective 7 days after filing with the Secretary of State

(By authority conferred on the director of the department of energy, labor and economic growth by sections 14 and 24 of 1974 PA 154, and Executive Reorganization Order Nos. 1996-1, 1996-2, 2003-18, and 2008-4, MCL 408.1014, 408.1024, 330.3101, 445.2001, 445.2011, and 445.2025)

Draft May 27, 2009

R 325.60601a, R 325.60601b, R 325.60602, R 325.60603, R 325.60604, R 325.60605, R 325.60606, R 325.60607, R 325.60608, R 325.60609, R 325.60610, R 325.60611, R 325.60612, R 325.60613, R 325.60614, R 325.60615, R 325.60616, R 325.60617, and R 325.60618 are added to the Michigan Administrative code and O.H. Rule 2410 is rescinded as follows:

PART 381. IONIZING RADIATION

R 325.60601a Definitions.

Rule 1a. Definitions applicable to these rules.

(1) "Radiation" includes alpha rays, beta rays, gamma rays, x-rays, neutrons, high-speed electrons, high-speed protons, and other atomic particles; but the term does not include sound or radio waves, visible light, or infrared or ultraviolet light.

(2) "Radioactive material" means any material which emits, by spontaneous nuclear disintegration, corpuscular or electromagnetic emanations.

(3) "Restricted area" means any area access to which is controlled by the employer for purposes of protection of individuals from exposure to radiation or radioactive materials.

(4) "Unrestricted area" means any area access to which is not controlled by the employer for purposes of protection of individuals from exposure to radiation or radioactive materials.

(5) "Dose" means the quantity of ionizing radiation absorbed, per unit of mass, by the body or by any portion of the body. When the provisions in these rules specify a dose during a period of time, the dose is the total quantity of radiation absorbed, per unit of mass, by the body or by any portion of the body during such period of time. Several different units of dose are in current use. Definitions of units used in these rules are set forth in subrules (6) and (7) of this rule.

(6) "Rad" means a measure of the dose of any ionizing radiation to body tissues in terms of the energy absorbed per unit of mass of the tissue. One rad is the dose corresponding to the absorption of 100 ergs per gram of tissue (1 millirad (mrad) = 0.001 rad).

(7) "Rem" means a measure of the dose of any ionizing radiation to body tissue in terms of its estimated biological effect relative to a dose of 1 roentgen (r) of x-rays (1 millirem (mrem) = 0.001 rem). The relation of the rem to other dose units depends upon the biological effect under consideration and upon the conditions for irradiation. Each of the following is considered to be equivalent to a dose of 1 rem:

- (a) A dose of 1 roentgen due to x- or gamma radiation.
- (b) A dose of 1 rad due to x-, gamma, or beta radiation.
- (c) A dose of 0.1 rad due to neutrons or high-energy protons.
- (d) A dose of 0.05 rad due to particles heavier than protons and with sufficient energy to reach the lens of the eye.
- (e) If it is more convenient to measure the neutron flux, or equivalent, than to determine the neutron dose in rads, as provided in subrule (7)(c) of this rule, 1 rem of neutron radiation may, for purposes of these rules, be assumed to be equivalent to 14 million neutrons per square centimeter incident upon the body; or, if there is sufficient information to estimate with reasonable accuracy the approximate distribution in energy of the neutrons, the incident number of neutrons per square centimeter equivalent to 1 rem may be estimated from table G-17:

TABLE G-17--NEUTRON FLUX DOSE EQUIVALENTS

Neutron energy (million electron volts (Mev))	Number of neutrons per square centimeter equivalent to a dose of 1 rem (neutrons/cm ²)	Average flux to deliver 100 millirem in 40 hours (neutrons/cm ² per sec.)
Thermal	970 x 10 ⁶	670
0.0001	720 x 10 ⁶	500
0.005	820 x 10 ⁶	570
0.02	400 x 10 ⁶	280
0.1	120 x 10 ⁶	80
0.5	43 x 10 ⁶	30
1.0	26 x 10 ⁶	18
2.5	29 x 10 ⁶	20
5.0	26 x 10 ⁶	18
7.5	24 x 10 ⁶	17
10	24 x 10 ⁶	17
10 to 30	14 x 10 ⁶	10

(8) For determining exposures to x- or gamma rays up to 3 Mev., the dose limits specified in these rules may be assumed to be equivalent to the "air dose." For the purpose of these rules "air dose" means that the dose is measured by a properly calibrated appropriate instrument in air at or near the body surface in the region of the highest dosage rate.

R 325.60601b Availability of referenced documents.

Rule 1b. (1) The following Michigan occupational safety and health standards are referenced in these rules. Up to 5 copies of these standards may be obtained at no charge from the Michigan

Department of Energy, Labor and Economic Growth, MIOSHA Standards Section, 7150 Harris Drive, P.O. Box 30643, Lansing, Michigan, 48909-8143 or via the internet at website: <http://www.michigan.gov/mioshastandards>. For quantities greater than 5, the cost, as of the time of adoption of these rules, is 4 cents per page.

- (a) Occupational health standard part 529 welding, cutting, & brazing, rule 3240.
- (b) Occupational health standard part 476 specifications for accident prevention signs and tags, rule 4501.

(c) Occupational health standard for pulp, paper, and paperboard mills, rule 5001.

(2) The following United States government standards are referenced in these rules and are available without cost as of the time of adoption of these rules by accessing United States government websites:

(a) The United States department of transportation, title 49, chapter I--pipeline and hazardous materials safety administration is available for no cost at:

http://www.access.gpo.gov/nara/cfr/waisidx_07/49cfrv2_07.html.

(b) The United States department of energy, title 10, chapter I--nuclear regulatory commission, part 20--standards for protection against radiation is available for no cost at

http://www.access.gpo.gov/nara/cfr/waisidx_08/10cfr20_08.html.

(c) The United States atomic energy act of 1954, as amended (42 U.S.C. 2011 et seq.) is available for no cost at: <http://www.nrc.gov/reading-rm/doc-collections/nuregs/staff/sr0980/rev1/vol-1-sec-1.pdf>.

(3) The American national standards institute Z54.1, nonmedical x-ray and sealed gamma-ray sources, 1963 edition is adopted by reference in these rules and is available from IHS Global, 15 Inverness Way East, Englewood, Colorado, 80112, USA, telephone number: 1-800-854-7179 or via the internet at website: <http://global.ihs.com>; at a cost of \$49.00 as of the time of adoption of these rules.

(4) The standards referenced in this rule are also available for inspection at the Department of Energy, Labor and Economic Growth, MIOSHA Standards Section, 7150 Harris Drive, P.O. Box 30643, Lansing, Michigan, 48909-8143.

(5) Copies of the standards referenced in subrules (2) and (3) of this rule may also be obtained from the Department of Energy, Labor and Economic Growth, MIOSHA Standards Section, 7150 Harris Drive, P.O. Box 30643, Lansing, Michigan, 48909-8143, at the respective cost charged in each subrule, plus \$20.00 for shipping and handling.

R 325.60602 Exposure of individuals to radiation in restricted areas.

Rule 2. (1) Except as provided in subrule (2) of this rule, no employer shall possess, use, or transfer sources of ionizing radiation in such a manner as to cause any individual in a restricted area to receive in any period of 1 calendar quarter from sources in the employer's possession or control a dose in excess of the limits specified in table G-18.

TABLE G-18

	Rems per calendar quarter
Whole body: Head and trunk; active bloodforming organs; lens of eyes; or gonads	1¼
Hands and forearms; feet and ankles	18¾

Skin of whole body	7½
--------------------	----

(2) An employer may permit an individual in a restricted area to receive doses to the whole body greater than those permitted under subrule (1) of this rule, if all of the following apply:

(a) During any calendar quarter the dose to the whole body does not exceed 3 rems.
 (b) The dose to the whole body, when added to the accumulated occupational dose to the whole body, does not exceed 5 (N-18) rems, where "N" equals the individual's age in years at his or her last birthday.

(c) The employer maintains adequate past and current exposure records which show that the addition of such a dose will not cause the individual to exceed the amount authorized in this rule. As used in this rule, "dose to the whole body" includes any dose to the whole body, gonad, active bloodforming organs, head and trunk, or lens of the eye.

(3) An employer shall not permit any employee who is under 18 years of age to receive in any period of 1 calendar quarter a dose in excess of 10 percent of the limits specified in table G-18.

(4) "Calendar quarter" means any 3-month period determined in 1 of the following ways:

(a) The first period of any year may begin on any date in January if the second, third, and fourth periods accordingly begin on the same date in April, July, and October, respectively, and the fourth period extends into January of the succeeding year, if necessary to complete a 3-month quarter. During the first year of use of this method of determination, the first period for that year shall also include any additional days in January preceding the starting date of the first period.

(b) The first period in a calendar year of 13 complete, consecutive calendar weeks; the second period in a calendar year of 13 complete, consecutive weeks; the third period in a calendar year of 13 complete, consecutive calendar weeks; the fourth period in a calendar year of 13 complete, consecutive calendar weeks. If at the end of a calendar year there are any days not falling within a complete calendar week of that year, such days shall be included within the last complete calendar week of that year. If at the beginning of any calendar year there are days not falling within a complete calendar week of that year, such days shall be included within the last complete calendar week of the previous year.

(c) The 4 periods in a calendar year may consist of the first 14 complete, consecutive calendar weeks; the next 12 complete, consecutive calendar weeks, the next 14 complete, consecutive calendar weeks, and the last 12 complete, consecutive calendar weeks. If at the end of a calendar year there are any days not falling within a complete calendar week of that year, such days shall be included (for purposes of these rules) within the last complete calendar week of the year. If at the beginning of any calendar year there are days not falling within a complete calendar week of that year, such days shall be included (for purposes of these rules) within the last complete week of the previous year.

R 325.60603 Exposure to airborne radioactive material.

Rule 3. (1) An employer shall not possess, use, or transport radioactive material in such a manner as to do the following:

(a) Cause any employee, within a restricted area, to be exposed to airborne radioactive material in an average concentration in excess of the limits specified in table 1 of appendix B to 10 CFR Part 20. The limits given in table 1 are for exposure to the concentrations specified for 40 hours in any workweek of 7 consecutive days. In any such period where the number of hours of exposure is less than 40, the limits specified in the table may be increased proportionately. In any such period where the number of hours of exposure is greater than 40, the limits specified in the table shall be decreased proportionately.

(b) Cause any individual within a restricted area, who is under 18 years of age, to be exposed to airborne radioactive material in an average concentration in excess of the limits specified in table II of appendix B to 10 CFR Part 20. For purposes of this rule, concentrations may be averaged over periods not greater than 1 week.

(2) "Exposed" as used in this rule means that the individual is present in an airborne concentration.

(3) No allowance shall be made for the use of protective clothing, equipment, or particle size.

R 325.60604 Precautionary procedures and personal monitoring.

Rule 4. (1) Every employer shall evaluate the radiation hazards incident to the production, use, release, disposal, or presence of radioactive materials or other sources of radiation under a specific set of conditions. When appropriate, such evaluation shall include a physical survey of the location of materials and equipment, and measurements of levels of radiation or concentrations of radioactive material present.

(2) Every employer shall supply appropriate personnel monitoring equipment, such as film badges, pocket chambers, pocket dosimeters, or film rings, and shall require the use of such equipment by employees as follows:

(a) Each employee who enters a restricted area under such circumstances that he or she receives, or is likely to receive, a dose in any calendar quarter in excess of 25 percent of the applicable value specified in R 325.60602(1).

(b) Each employee less than 18 years of age who enters a restricted area where he or she receives, or is likely to receive, a dose in any calendar quarter in excess of 5 percent of the applicable value specified in R 325.60602(1).

(c) Each employee who enters a high radiation area.

(3) As used in these rules:

(a) "Personnel monitoring equipment" means devices designed to be worn or carried by an individual for the purpose of measuring the dose received (for example, film badges, pocket chambers, pocket dosimeters, film rings).

(b) "Radiation area" means any area, accessible to personnel, in which there exists radiation at such levels that a major portion of the body could receive in any 1 hour a dose in excess of 5 millirem, or in any 5 consecutive days a dose in excess of 100 millirem.

(c) "High radiation area" means any area, accessible to personnel, in which there exists radiation at such levels that a major portion of the body could receive in any 1 hour a dose in excess of 100 millirem.

R 325.60605 Caution signs, labels, and signals.

Rule 5. (1) Symbols prescribed by this rule shall use the conventional radiation caution colors (magenta or purple on yellow background). The symbol prescribed by this rule is the conventional 3-bladed design.

FIGURE G-10

RADIATION SYMBOL

1. Cross-hatched area is to be magenta or purple.
2. Background is to be yellow.

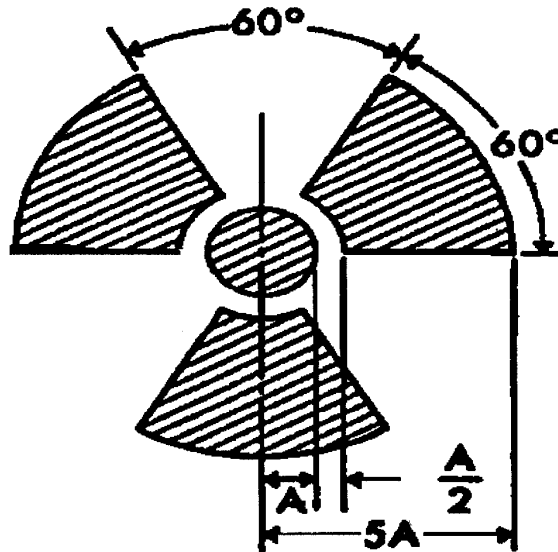

(2) Radiation area. Each radiation area shall be conspicuously posted with a sign or signs bearing the radiation caution symbol described in subrule (1) of this rule and the following words:

CAUTION
RADIATION AREA

- (3) The following apply to high radiation area:
- (a) Each high radiation area shall be conspicuously posted with a sign or signs bearing the radiation caution symbol and the following words:

CAUTION
HIGH RADIATION AREA

(b) Each high radiation area shall be equipped with a control device which shall either cause the level of radiation to be reduced below that at which an individual might receive a dose of 100 millirems in 1 hour upon entry into the area or shall energize a conspicuous visible or audible alarm signal in a manner that the individual entering and the employer or a supervisor of the activity are made aware of the entry. In the case of a high radiation area established for a period of 30 days or less, such control device is not required.

- (4) The following apply to airborne radioactivity area:
- (a) As used in these rules, "airborne radioactivity area" means either of the following:
- (i) Any room, enclosure, or operating area in which airborne radioactive materials, composed wholly or partly of radioactive material, exist in concentrations in excess of the amounts specified in column 1 of table 1 of appendix B to 10 CFR Part 20.

(ii) Any room, enclosure, or operating area in which airborne radioactive materials exist in concentrations which, averaged over the number of hours in any week during which individuals are in the area, exceed 25 percent of the amounts specified in column 1 of table 1 of appendix B to 10 CFR Part 20.

(b) Each airborne radioactivity area shall be conspicuously posted with a sign or signs bearing the radiation caution symbol described in subrule (1) of this rule and the following words:

**CAUTION
AIRBORNE RADIOACTIVITY AREA**

(5) The following apply to additional requirements:

(a) Each area or room in which radioactive material is used or stored and which contains any radioactive material (other than natural uranium or thorium) in any amount exceeding 10 times the quantity of such material specified in appendix C to 10 CFR Part 20 shall be conspicuously posted with a sign or signs bearing the radiation caution symbol described in subrule (1) of this rule and the following words:

**CAUTION
RADIOACTIVE MATERIALS**

(b) Each area or room in which natural uranium or thorium is used or stored in an amount exceeding 100 times the quantity of such material specified in appendix C to 10 CFR Part 20 shall be conspicuously posted with a sign or signs bearing the radiation caution symbol described in subrule (1) of this rule and the following words:

**CAUTION
RADIOACTIVE MATERIALS**

(6) The following apply to containers:

(a) Each container in which is transported, stored, or used a quantity of any radioactive material (other than natural uranium or thorium) greater than the quantity of such material specified in appendix C to 10 CFR Part 20 shall bear a durable, clearly visible label bearing the radiation caution symbol described in subrule (1) of this rule and the following words:

**CAUTION
RADIOACTIVE MATERIALS**

(b) Each container in which natural uranium or thorium is transported, stored, or used in a quantity greater than 10 times the quantity specified in appendix C to 10 CFR Part 20 shall bear a durable, clearly visible label bearing the radiation caution symbol described in subrule (1) of this rule and the following words:

**CAUTION
RADIOACTIVE MATERIALS**

(c) Notwithstanding the provisions of subrule (6)(a) and (b) of this rule a label shall not be required under either of the following circumstances:

(i) If the concentration of the material in the container does not exceed that specified in column 2 of table 1 of appendix B to 10 CFR Part 20.

(ii) For laboratory containers, such as beakers, flasks, and test tubes, used transiently in laboratory procedures, when the user is present.

(d) Where containers are used for storage, the labels required in this subrule shall state also the quantities and kinds of radioactive materials in the containers and the date of measurement of the quantities.

Also see Occupational Health Standard Part 476 Specifications for Accident Prevention Signs and Tags, Rule 4501.

R 325.60606 Immediate evacuation warning signal.

Rule 6. (1) The following apply to signal characteristics:

(a) The signal shall be a midfrequency complex sound wave amplitude modulated at a subsonic frequency. The complex sound wave in free space shall have a fundamental frequency (f_1) between 450 and 500 hertz (Hz) modulated at a subsonic rate between 4 and 5 hertz.

(b) The signal generator shall not be less than 75 decibels at every location where an individual may be present whose immediate, rapid, and complete evacuation is essential.

(c) A sufficient number of signal units shall be installed so the requirements of subrule (1)(b) of this rule are met at every location where an individual may be present whose immediate, rapid, and complete evacuation is essential.

(d) The signal shall be unique in the plant or facility in which it is installed.

(e) The minimum duration of the signal shall be sufficient to ensure that all affected persons hear the signal.

(f) The signal-generating system shall respond automatically to an initiating event without requiring any human action to sound the signal.

(2) The following apply to design objectives:

(a) The signal-generating system shall be designed to incorporate components which enable the system to produce the desired signal each time it is activated within one-half second of activation.

(b) The signal-generating system shall be provided with an automatically activated secondary power supply which is adequate to simultaneously power all emergency equipment to which it is connected, if operation during power failure is necessary, except in those systems using batteries as the primary source of power.

(c) All components of the signal-generating system shall be located to provide maximum practicable protection against damage in case of fire, explosion, corrosive atmosphere, or other environmental extremes consistent with adequate system performance.

(d) The signal-generating system shall be designed with the minimum number of components necessary to make it function as intended, and should utilize components which do not require frequent servicing such as lubrication or cleaning.

(e) Where several activating devices feed activating information to a central signal generator, failure of any activating device shall not render the signal-generator system inoperable to activating information from the remaining devices.

(f) The signal-generating system shall be designed to enhance the probability that alarm occurs only when immediate evacuation is warranted. The number of false alarms shall not be so great that the signal will come to be disregarded and shall be low enough to minimize personal injuries or excessive property damage that might result from such evacuation.

(3) The following apply to testing:

(a) Initial tests, inspections, and checks of the signal-generating system shall be made to verify that the fabrication and installation were made according to design plans and specifications and to develop a thorough knowledge of the performance of the system and all components under normal and hostile conditions.

(b) Once the system has been placed in service, periodic tests, inspections, and checks shall be made to minimize the possibility of malfunction.

(c) Following significant alterations or revisions to the system, tests and checks similar to the initial installation tests shall be made.

(d) Tests shall be designed to minimize hazards while conducting the tests.

(e) Before normal operation, the signal-generating system shall be checked physically and functionally to assure reliability and to demonstrate accuracy and performance. Specific tests shall include all of the following:

(i) All power sources.

(ii) Calibration and calibration stability.

(iii) Trip levels and stability.

(iv) Continuity of function with loss and return of required services such as AC or DC power and air pressure.

(v) All indicators.

(vi) Trouble indicator circuits and signals, where used.

(vii) Air pressure, if used.

(viii) Determine that sound level of the signal is within the limit of subrule (1)(b) of this rule at all points that require immediate evacuation.

(f) In addition to the initial startup and operating tests, periodic scheduled performance tests and status checks shall be made to ensure that the system is at all times operating within design limits and capable of the required response. Specific periodic tests or checks or both shall include all of the following:

(i) Adequacy of signal activation device.

(ii) All power sources.

(iii) Function of all alarm circuits and trouble indicator circuits including trip levels.

(iv) Air pressure (if used).

(v) Function of entire system including operation without power where required.

(vi) Complete operational tests including sounding of the signal and determination that sound levels are adequate.

(g) Periodic tests shall be scheduled on the basis of need, experience, difficulty, and disruption of operations. The entire system shall be operationally tested at least quarterly.

(h) All employees whose work may necessitate their presence in an area covered by the signal shall be made familiar with the actual sound of the signal--preferably as it sounds at their work location. Before placing the system into operation, all employees normally working in the area shall be made acquainted with the signal by actual demonstration at their work locations.

R 325.60607 Posting requirements; exemptions.

Rule 7. Notwithstanding the provisions of R 325.60605 all of the following apply:

(a) A room or area is not required to be posted with a caution sign because of the presence of a sealed source if the radiation level 12 inches from the surface of the source container or housing does not exceed 5 millirem per hour.

(b) Rooms or other areas in onsite medical facilities are not required to be posted with caution signs because of the presence of patients containing radioactive material if there are personnel in

attendance who shall take the precautions necessary to prevent the exposure of any individual to radiation or radioactive material in excess of the limits established in these rules.

(c) Caution signs are not required to be posted at areas or rooms containing radioactive materials for periods of less than 8 hours if both of the following apply:

(i) The materials are constantly attended during such periods by an individual who shall take the precautions necessary to prevent the exposure of any individual to radiation or radioactive materials in excess of the limits established in these rules.

(ii) The area or room is subject to the employer's control.

R 325.60608 Radioactive materials packaged for shipment; exemptions.

Rule 8. Radioactive materials packaged and labeled in accordance with regulations of the department of transportation published in 49 CFR Chapter I, are exempt from the labeling and posting requirements of this rule during shipment if the inside containers are labeled according to R 325.60605.

R 325.60609 Instruction of personnel; posting.

Rule 9. (1) Employers regulated by the nuclear regulatory commission shall be governed by 10 CFR part 20 standards. Employers in a state named in R 325.60616(3) shall be governed by the requirements of the laws and regulations of that state. All other employers shall be subject to subrules (2) and (3) of this rule.

(2) The employer shall do all of the following:

(a) Inform all individuals working in or frequenting any portion of a radiation area of the occurrence of radioactive materials or of radiation in such portions of the radiation area.

(b) Instruct all individuals in the safety problems associated with exposure to such materials or radiation and in precautions or devices to minimize exposure and the applicable provisions of these rules for the protection of employees from exposure to radiation or radioactive materials.

(c) Advise all individuals of reports of radiation exposure which employees may request under these rules.

(3) Each employer to whom these rules apply shall do either of the following:

(a) Conspicuously post a current copy of its provisions and a copy of the operating procedures applicable to the work in locations where employees working in or frequenting radiation areas will observe these documents on the way to and from their place of employment.

(b) Keep documents available for examination of employees upon request.

R 325.60610 Storage of radioactive materials.

Rule 10. Radioactive materials stored in a nonradiation area shall be secured against unauthorized removal from the place of storage.

R 325.60611 Waste disposal.

Rule 11. An employer shall not dispose of radioactive material except by transfer to an authorized recipient, or in a manner approved by the nuclear regulatory commission or a state named in R 325.60616(3).

R 325.60612 Notification of incidents.

Rule 12. (1) Immediate notification. Each employer shall immediately notify the department of environmental quality for employees not protected by the nuclear regulatory commission by means of 10 CFR Part 20; R 325.60616(2) or the requirements of the laws and regulations of states

named in R 325.60616(3) by telephone or telegraph of any incident involving radiation which may have caused or threatens to cause either of the following:

(a) Exposure of the whole body of any individual of 25 rems or more of radiation; exposure of the skin of the whole body of any individual to 150 rems or more of radiation; or exposure of the feet, ankles, hands, or forearms of any individual to 375 rems or more of radiation.

(b) The release of radioactive material in concentrations which, if averaged over a period of 24 hours, would exceed 5,000 times the limit specified for such materials in table II of appendix B to 10 CFR Part 20.

(2) Twenty-four hour notification. Each employer shall within 24 hours following its occurrence notify the department of environmental quality for employees not protected by the nuclear regulatory commission by means of 10 CFR Part 20; R 325.60616(2) or the requirements of the laws and regulations of States named in R 325.60616(3) by telephone or telegraph of any incident involving radiation which may have caused or threatens to cause any of the following:

(a) Exposure of the whole body of any individual to 5 rems or more of radiation.

(b) Exposure of the skin of the whole body of any individual to 30 rems or more of radiation.

(c) Exposure of the feet, ankles, hands, or forearms to 75 rems or more of radiation.

R 325.60613 Reports of overexposure and excessive levels and concentrations.

Rule 13. (1) In addition to any notification required by R 325.60612 each employer shall make a written report within 30 days to the department of environmental quality for employees not protected by the nuclear regulatory commission by means of 10 CFR part 20; or under R 325.60616(2) or the requirements of the laws and regulations of states named in R 325.60616(3) of each exposure of an individual to radiation or concentrations of radioactive material in excess of any applicable limit in these rules. Each report required under this rule shall describe the extent of exposure of persons to radiation or to radioactive material; levels of radiation and concentration of radioactive material involved, the cause of the exposure, levels of concentrations; and corrective steps taken or planned to assure against a recurrence.

(2) If an employer is required under this rule to report to the department of environmental quality any exposure of an individual to radiation or to concentrations of radioactive material, the employer shall also notify that individual of the nature and extent of exposure. The notice shall be in writing and shall contain the following statement: "You should preserve this report for future reference."

R 325.60614 Records.

Rule 14. (1) Every employer shall maintain records of the radiation exposure of all employees for whom personnel monitoring is required under R 325.60604 and advise each employee of their individual exposure on at least an annual basis.

(2) Every employer shall maintain records in the same units used in tables in R 325.60602 and appendix B to 10 CFR Part 20.

R 325.60615 Disclosure to former employee of individual employee's records.

Rule 15. At the request of a former employee, an employer shall furnish to the employee a report of the employee's exposure to radiation as shown in records maintained by the employer under R 325.60614(1). The report shall be furnished within 30 days from the time the request is made and shall cover each calendar quarter of the individual's employment involving exposure to radiation or for a lesser period if requested by the employee. The report shall also include the results of any calculations and analysis of radioactive material deposited in the body of the

employee. The report shall be in writing and contain the following statement: "You should preserve this report for future reference."

R 325.60616 Nuclear regulatory commission licensees—NRC contractors operating NRC plants and facilities—NRC agreement state licensees or registrants.

Rule 16. (1) Any employer who possesses or uses source material, byproduct material, or special nuclear material, as defined in the atomic energy act of 1954, as amended, under a license issued by the nuclear regulatory commission and in accordance with the requirements of 10 CFR part 20 shall be deemed to be in compliance with these rules with respect to possession and use.

(2) NRC contractors operating NRC plants and facilities: Any employer who possesses or uses source material, byproduct material, special nuclear material, or other radiation sources under a contract with the nuclear regulatory commission for the operation of NRC plants and facilities and in accordance with the standards, procedures, and other requirements for radiation protection established by the commission for such contract pursuant to the atomic energy act of 1954, as amended (42 U.S.C. 2011 et seq.), shall be deemed to be in compliance with these rules with respect to possession and use.

(3) NRC—agreement state licensees or registrants the following apply:

(a) Atomic energy act sources. Any employer who possesses or uses source material, byproduct material, or special nuclear material, as defined in the atomic energy act of 1954, as amended (42 U.S.C. 2011 et seq.), and has either registered such sources with, or is operating under a license issued by, a state which has an agreement in effect with the nuclear regulatory commission under section 274(b) (42 U.S.C. 2021(b)) of the atomic energy act of 1954, as amended, and according to the state's laws and regulations, shall be deemed to be in compliance with the radiation requirements of these rules, insofar as his or her possession and use of such material is concerned, unless the Secretary of Labor, after conference with the nuclear regulatory commission, shall determine that the state's program for control of these radiation sources is incompatible with the requirements of these rules. Such agreements currently are in effect only in the states of Alabama, Arkansas, California, Kansas, Kentucky, Florida, Mississippi, New Hampshire, New York, North Carolina, Texas, Tennessee, Oregon, Idaho, Arizona, Colorado, Louisiana, Nebraska, Washington, Maryland, North Dakota, South Carolina, and Georgia.

(b) Other sources. Any employer who possesses or uses radiation sources other than source material, byproduct material, or special nuclear material, as defined in the atomic energy act of 1954, as amended (42 U.S.C. 2011 et seq.), and has either registered such sources with, or is operating under a license issued by a state which has an agreement in effect with the nuclear regulatory commission pursuant to section 274(b) (42 U.S.C. 2021(b)) of the atomic energy act of 1954, as amended, and in accordance with the requirements of that state's laws and regulations shall be deemed to be in compliance with the radiation requirements of these rules, as far as his or her possession and use of such material is concerned, if the state's program for control of these radiation sources is the subject of a currently effective determination by the assistant secretary of labor that such program is compatible with these rules. Such determinations currently are in effect only in the states of Alabama, Arkansas, California, Kansas, Kentucky, Florida, Mississippi, New Hampshire, New York, North Carolina, Texas, Tennessee, Oregon, Idaho, Arizona, Colorado, Louisiana, Nebraska, Washington, Maryland, North Dakota, South Carolina, and Georgia.

R 325.60617 Machine rooms in pulp, paper, and paperboard mills covered by Rule 5001 radiation.

Rule 17. Special standards regarding the use of radiation equipment shall be posted and followed as required by these rules.

R 325.60618 X-ray control in welding, cutting, and brazing covered by Rule 3240.

Rule 18. (1) Transmission pipeline: x-ray inspection. The use of x-rays and radioactive isotopes for the inspection of welded pipeline joints shall be carried out in conformance with the American national standards institute Z54.1, safety standard for nonmedical x-ray and sealed gamma-ray sources, as adopted in R 325.60601b.

(2) Mechanical piping systems: x-ray inspection. The use of x-rays and radioactive isotopes for the inspection of welded piping joints shall be in conformance with the American national standards institute Z54.1, safety standard for nonmedical x-ray and sealed gamma-ray sources, as adopted in R 325.60601b.

Rule 2410 Ionizing Radiation Rescinded.

~~(Source: 1910.96—entire section, except as noted)~~

~~—(1) Definitions applicable to this rule.~~

~~—(a) "Radiation" includes alpha rays, beta rays, gamma rays, X rays, neutron, high speed electrons, high speed protons, and other atomic particles; but such term does not include sound or radio waves, or visible light, or infrared or ultraviolet light.~~

~~—(b) "Radioactive material" means any material which emits, by spontaneous nuclear disintegration, corpuscular or electromagnetic emanations.~~

~~—(c) "Restricted area" means any area access to which is controlled by the employer for purposes of protection of individuals from exposure to radiation or radioactive materials.~~

~~—(d) "Unrestricted area" means any area access to which is not controlled by the employer for purposes of protection of individuals from exposure to radiation or radioactive materials.~~

~~—(e) "Dose" means the quantity of ionizing radiation absorbed, per unit of mass, by the body or by any portion of the body. When the provisions in this rule specify a dose during a period of time, the dose is the total quantity of radiation absorbed, per unit of mass, by the body or by any portion of the body during such period of time. Several different units of dose are in current use. Definitions of units used in this rule are set forth in paragraphs (f) and (g) of this subsection.~~

~~—(f) "Rad" means a measure of the dose of any ionizing radiation to body tissues in terms of the energy absorbed per unit of mass of the tissue. One rad is the dose corresponding to the absorption of 100 ergs per gram of tissue (1 millirad (mrad) = 0.001 rad).~~

~~—(g) "Rem" means a measure of the dose of any ionizing radiation to body tissue in terms of its estimated biological effect relative to a dose of 1 roentgen (r) of Xrays (1 millirem (mrem) = 0.001 rem). The relation of the rem to other dose units depends upon the biological effect under consideration and upon the conditions for irradiation. Each of the following is considered to be equivalent to a dose of 1 rem:~~

~~—(i) A dose of 1 (r) due to X or gamma radiation;~~

~~—(ii) A dose of 1 rad due to X, gamma, or beta radiation;~~

~~—(iii) A dose of 0.1 rad due to neutrons or high energy protons;~~

~~—(iv) A dose of 0.05 rad due to particles heavier than protons and with sufficient energy to reach the lens of the eye;~~

~~—(v) If it is more convenient to measure the neutron flux, or equivalent, than to determine the neutron dose in rads, as provided in subdivision (iii) of this paragraph, 1 rem of neutron radiation may, for purposes of the provisions in this rule may be assumed to be equivalent to 14 million neutrons per square centimeter incident upon the body; or, if there is sufficient information to estimate with~~

reasonable accuracy the approximate distribution in energy of the neutrons, the incident number of neutrons per square centimeter equivalent to 1 rem may be estimated from Table G-17.

TABLE G-17—NEUTRON FLUX DOSE EQUIVALENTS

Neutron energy (million electron volts (Mev))	Number of neutrons per square centimeter equivalent to a dose of 1 rem (neutrons/cm ²)	Average flux to deliver 100 millirem in 40 hours (neutrons/cm ² per sec.)
Thermal	970×10^6	670
0.0001	720×10^6	500
0.005	820×10^6	570
0.02	400×10^6	280
0.1	120×10^6	80
0.5	43×10^6	30
1.0	26×10^6	18
2.5	29×10^6	20
5.0	26×10^6	18
7.5	24×10^6	17
10	24×10^6	17
10 to 30	14×10^6	10

—(h) For determining exposures to X or gamma rays up to 3 Mev., the dose limits specified in this rule may be assumed to be equivalent to the "air dose". For the purpose of this rule "air dose" means that the dose is measured by a properly calibrated appropriate instrument in air at or near the body surface in the region of the highest dosage rate.

—(2) Exposure of individuals to radiation in restricted areas:

—(a) Except as provided in paragraph (b) of this subsection, no employer shall possess, use, or transfer sources of ionizing radiation in such a manner as to cause any individual in a restricted area to receive in any period of one calendar quarter from sources in the employer's possession or control a dose in excess of the limits specified in Table G-18.

TABLE G-18

	Rems per calendar quarter
Whole body: Head and trunk; active blood-forming organs; lens of eyes; or gonads	1-1/4
Hands and forearms; feet and ankles	18-3/4
Skin of whole body	7-1/2

—(b) An employer may permit an individual in a restricted area to receive doses to the whole body greater than those permitted under paragraph (a) of this subsection, so long as:

—(i) During any calendar quarter the dose to the whole body shall not exceed 3 rems; and

—(ii) The dose to the whole body, when added to the accumulated occupational dose to the whole body, shall not exceed $5(N-18)$ rems, where "N" equals the individual's age in years at his last birthday; and

—(iii) The employer maintains adequate past and current exposure records which show that the addition of such a dose will not cause the individual to exceed the amount authorized in this paragraph. As used in this paragraph, "dose to the whole body" shall be deemed to include any dose to the whole body, gonad, active blood-forming organs, head and trunk, or lens of the eye.

—(c) No employer shall permit any employee who is under 18 years of age to receive in any period of one calendar quarter a dose in excess of 10 percent of the limits specified in Table G-18.

—(d) "Calendar quarter" means any 3-month period determined as follows:

~~—(i) The first period of any year may begin on any date in January: Provided, That the second, third, and fourth periods accordingly begin on the same date in April, July, and October, respectively, and that the fourth period extends into January of the succeeding year, if necessary to complete a 3-month quarter. During the first year of use of this method of determination, the first period for that year shall also include any additional days in January preceding the starting date of the first period; or~~

~~—(ii) The first period in a calendar year of 13 complete, consecutive calendar weeks; the second period in a calendar year of 13 complete, consecutive weeks; the third period in a calendar year of 13 complete, consecutive calendar weeks; the fourth period in a calendar year of 13 complete, consecutive calendar weeks. If at the end of a calendar year there are any days not falling within a complete calendar week of that year, such days shall be included within the last complete calendar week of that year. If at the beginning of any calendar year there are days not falling within a complete calendar week of that year, such days shall be included within the last complete calendar week of the previous year; or~~

~~—(iii) The four periods in a calendar year may consist of the first 14 complete, consecutive calendar weeks; the next 12 complete, consecutive calendar weeks, the next 14 complete, consecutive calendar weeks, and the last 12 complete, consecutive calendar weeks. If at the end of a calendar year there are any days not falling within a complete calendar week of that year, such days shall be included (for purposes of this rule) within the last complete calendar week of the year. If at the beginning of any calendar year there are days not falling within a complete calendar week of that year, such days shall be included (for purposes of this rule) within the last complete week of the previous year.~~

~~—(e) No employer shall change the method used by him to determine calendar quarters except at the beginning of a calendar year.~~

~~—(3) Exposure to airborne radioactive material.~~

~~—(a) No employer shall possess, use or transport radioactive material in such a manner as to cause any employee, within a restricted area, to be exposed to airborne radioactive material in an average concentration in excess of the limits specified in Table 1 of Appendix B to 10 CFR Part 20. The limits given in Table 1 are for exposure to the concentrations specified for 40 hours in any workweek of 7 consecutive days. In any such period where the number of hours of exposure is less than 40, the limits specified in the table may be increased proportionately. In any such period where the number of hours of exposure is greater than 40, the limits specified in the table shall be decreased proportionately.~~

~~—(b) No employer shall possess, use, or transfer radioactive material in such a manner as to cause any individual within a restricted area, who is under 18 years of age, to be exposed to airborne radioactive material in an average concentration in excess of the limits specified in Table II of Appendix B to 10 CFR Part 20. For purposes of this paragraph, concentrations may be averaged over periods not greater than 1 week.~~

~~—(c) "Exposed" as used in this subsection means that the individual is present in an airborne concentration. No allowance shall be made for the use of protective clothing or equipment, or particle size.~~

~~—(4) Precautionary procedures and personal monitoring.~~

~~—(a) Every employer shall make such surveys as may be necessary for him to comply with the provisions of this rule. "Survey" means an evaluation of the radiation hazards incident to the production, use, release, disposal, or presence of radioactive materials or other sources of radiation under a specific set of conditions. When appropriate, such evaluation includes a physical survey of the location of materials and equipment, and measurements of levels of radiation or concentrations of radioactive material present.~~

~~—(b) Every employer shall supply appropriate personnel monitoring equipment, such as film badges, pocket chambers, pocket dosimeters, or film rings, to, and shall require the use of such equipment by:~~

- (i) Each employee who enters a restricted area under such circumstances that he receives, or is likely to receive, a dose in any calendar quarter in excess of 25 percent of the applicable value specified in paragraph (2)(a) of this rule; and
 - (ii) Each employee under 18 years of age who enters a restricted area under such circumstances that he receives, or is likely to receive, a dose in any calendar quarter in excess of 5 percent of the applicable value specified in paragraph (2)(a) of this rule; and
 - (iii) Each employee who enters a high radiation area.
- (c) As used in this rule:
- (i) "Personnel monitoring equipment" means devices designed to be worn or carried by an individual for the purpose of measuring the dose received (e.g., film badges, pocket chambers, pocket dosimeters, film rings, etc.);
 - (ii) "Radiation area" means any area, accessible to personnel, in which there exists radiation at such levels that a major portion of the body could receive in any 1 hour a dose in excess of 5 millirem, or in any 5 consecutive days in excess of 100 millirem; and
 - (iii) "High radiation area" means any area, accessible to personnel, in which there exists radiation at such levels that a major portion of the body could receive in any one hour a dose in excess of 100 millirem.
- (5) Caution signs, labels, and signals. (See also Rule 4501)
- (a) General:
- (i) Symbols prescribed by this subsection shall use the conventional radiation caution colors (magenta or purple on yellow background). The symbol prescribed by this subsection is the conventional three-bladed design.

FIGURE G-10

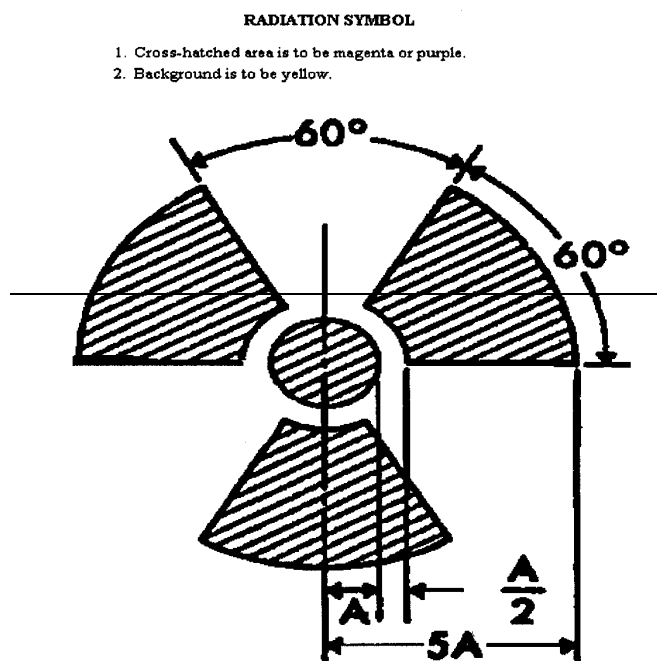

- (ii) In addition to the contents of signs and labels prescribed in this subsection, employers may provide on or near such signs and labels any additional information which may be appropriate in aiding individuals to minimize exposure to radiation or to radioactive material.

~~—(b) Radiation area. Each radiation area shall be conspicuously posted with a sign or signs bearing the radiation caution symbol described in paragraph (a) of this subsection and the words:~~

~~CAUTION
RADIATION AREA~~

~~—(c) High radiation area.~~

~~—(i) Each high radiation area shall be conspicuously posted with a sign or signs bearing the radiation caution symbol and the words:~~

~~CAUTION
HIGH RADIATION AREA~~

~~—(ii) Each high radiation area shall be equipped with a control device which shall either cause the level of radiation to be reduced below that at which an individual might receive a dose of 100 millirems in 1 hour upon entry into the area or shall energize a conspicuous visible or audible alarm signal in such a manner that the individual entering and the employer or a supervisor of the activity are made aware of the entry. In the case of a high radiation area established for a period of 30 days or less, such control device is not required.~~

~~—(d) Airborne radioactivity area.~~

~~—(i) As used in the provisions of this rule, "airborne radioactivity area" means:~~

~~—(A) Any room, enclosure, or operating area in which airborne radioactive materials, composed wholly or partly of radioactive material, exist in concentrations in excess of the amounts specified in column 1 of Table 1 of Appendix B to 10 CFR Part 20 or~~

~~—(B) Any room, enclosure, or operating area in which airborne radioactive materials exist in concentrations which, averaged over the number of hours in any week during which individuals are in the area, exceed 25 percent of the amounts specified in column 1 of Table 1 of Appendix B to 10 CFR Part 20.~~

~~—(ii) Each airborne radioactivity area shall be conspicuously posted with a sign or signs bearing the radiation caution symbol described in paragraph (a) of this subsection and the words:~~

~~CAUTION
AIRBORNE RADIOACTIVITY AREA~~

~~—(e) Additional requirements.~~

~~—(i) Each area or room in which radioactive material is used or stored and which contains any radioactive material (other than natural uranium or thorium) in any amount exceeding 10 times the quantity of such material specified in Appendix C to 10 CFR Part 20 shall be conspicuously posted with a sign or signs bearing the radiation caution symbol described in paragraph (a) of this subsection and the words:~~

~~CAUTION
RADIOACTIVE MATERIALS~~

~~—(ii) Each area or room in which natural uranium or thorium is used or stored in an amount exceeding 100 times the quantity of such material specified in 10 CFR Part 20 shall be conspicuously posted with a sign or signs bearing the radiation caution symbol described in paragraph (a) of this subsection and the words:~~

~~CAUTION
RADIOACTIVE MATERIALS~~

~~—(f) Containers.~~

~~—(i) Each container in which is transported, stored, or used a quantity of any radioactive material (other than natural uranium or thorium) greater than the quantity of such material specified in Appendix C to 10 CFR Part 20 shall bear a durable, clearly visible label bearing the radiation caution symbol described in paragraph (a) of this subsection and the words:~~

~~CAUTION~~

RADIOACTIVE MATERIALS

—(ii) Each container in which natural uranium or thorium is transported, stored, or used in a quantity greater than 10 times the quantity specified in Appendix C to 10 CFR Part 20 shall bear a durable, clearly visible label bearing the radiation caution symbol described in paragraph (a) of this subsection and the words:

CAUTION

RADIOACTIVE MATERIALS

—(iii) Notwithstanding the provisions of subdivisions (i) and (ii) of this paragraph a label shall not be required:

—(A) If the concentration of the material in the container does not exceed that specified in column 2 of Table 1 of Appendix B to 10 CFR Part 20, or

—(B) For laboratory containers, such as beakers, flasks, and test tubes, used transiently in laboratory procedures, when the user is present.

—(iv) Where containers are used for storage, the labels required in this subparagraph shall state also the quantities and kinds of radioactive materials in the containers and the date of measurement of the quantities.

—(6) Immediate evacuation warning signal.

—(a) Signal characteristics.

—(i) The signal shall be a midfrequency complex sound wave amplitude modulated at a subsonic frequency. The complex sound wave in free space shall have a fundamental frequency (f_1) between 450 and 500 hertz (Hz) modulated at a subsonic rate between 4 and 5 hertz.

—(ii) The signal generator shall not be less than 75 decibels at every location where an individual may be present whose immediate, rapid, and complete evacuation is essential.

—(iii) A sufficient number of signal units shall be installed such that the requirements of subdivision (ii) of this paragraph are met at every location where an individual may be present whose immediate, rapid, and complete evacuation is essential.

—(iv) The signal shall be unique in the plant or facility in which it is installed.

—(v) The minimum duration of the signal shall be sufficient to insure that all affected persons hear the signal.

—(vi) The signal-generating system shall respond automatically to an initiating event without requiring any human action to sound the signal.

—(b) Design objectives.

—(i) The signal-generating system shall be designed to incorporate components which enable the system to produce the desired signal each time it is activated within one-half second of activation.

—(ii) The signal-generating system shall be provided with an automatically activated secondary power supply which is adequate to simultaneously power all emergency equipment to which it is connected, if operation during power failure is necessary, except in those systems using batteries as the primary source of power.

—(iii) All components of the signal-generating system shall be located to provide maximum practicable protection against damage in case of fire, explosion, corrosive atmosphere, or other environmental extremes consistent with adequate system performance.

—(iv) The signal-generating system shall be designed with the minimum number of components necessary to make it function as intended, and should utilize components which do not require frequent servicing such as lubrication or cleaning.

—(v) Where several activating devices feed activating information to a central signal generator, failure of any activating device shall not render the signal-generator system inoperable to activating information from the remaining devices.

~~—(vi) The signal-generating system shall be designed to enhance the probability that alarm occurs only when immediate evacuation is warranted. The number of false alarms shall not be so great that the signal will come to be disregarded and shall be low enough to minimize personal injuries or excessive property damage that might result from such evacuation.~~

~~—(c) Testing.~~

~~—(i) Initial tests, inspections, and checks of the signal-generating system shall be made to verify that the fabrication and installation were made in accordance with design plans and specifications and to develop a thorough knowledge of the performance of the system and all components under normal and hostile conditions.~~

~~—(ii) Once the system has been placed in service, periodic tests, inspections, and checks shall be made to minimize the possibility of malfunction.~~

~~—(iii) Following significant alterations or revisions to the system, tests and checks similar to the initial installation tests shall be made.~~

~~—(iv) Tests shall be designed to minimize hazards while conducting the tests.~~

~~—(v) Prior to normal operation the signal-generating system shall be checked physically and functionally to assure reliability and to demonstrate accuracy and performance. Specific tests shall include:~~

~~—(A) All power sources.~~

~~—(B) Calibration and calibration stability.~~

~~—(C) Trip levels and stability.~~

~~—(D) Continuity of function with loss and return of required services such as AC or DC power, air pressure, etc.~~

~~—(E) All indicators.~~

~~—(F) Trouble indicator circuits and signals, where used.~~

~~—(G) Air pressure (if used).~~

~~—(H) Determine that sound level of the signal is within the limit of subparagraph (a)(ii) of this subsection at all points that require immediate evacuation.~~

~~—(vi) In addition to the initial startup and operating tests, periodic scheduled performance tests and status checks must be made to insure that the system is at all times operating within design limits and capable of the required response. Specific periodic tests or checks or both shall include:~~

~~—(A) Adequacy of signal activation device.~~

~~—(B) All power sources.~~

~~—(C) Function of all alarm circuits and trouble indicator circuits including trip levels.~~

~~—(D) Air pressure (if used).~~

~~—(E) Function of entire system including operation without power where required.~~

~~—(F) Complete operational tests including sounding of the signal and determination that sound levels are adequate.~~

~~—(vii) Periodic tests shall be scheduled on the basis of need, experience, difficulty, and disruption of operations. The entire system should be operationally tested at least quarterly.~~

~~—(viii) All employees whose work may necessitate their presence in an area covered by the signal shall be made familiar with the actual sound of the signal—preferably as it sounds at their work location. Before placing the system into operation, all employees normally working in the area shall be made acquainted with the signal by actual demonstration at their work locations.~~

~~—(7) Exceptions from posting requirements. Notwithstanding the provisions of subsection (5) of this rule:~~

~~—(a) A room or area is not required to be posted with a caution sign because of the presence of a sealed source, provided the radiation level 12 inches from the surface of the source container or housing does not exceed 5 millirem per hour.~~

- ~~—(b) Rooms or other areas in onsite medical facilities are not required to be posted with caution signs because of the presence of patients containing radioactive material, provided that there are personnel in attendance who shall take the precautions necessary to prevent the exposure of any individual to radiation or radioactive material in excess of the limits established in the provisions of this rule.~~
- ~~—(c) Caution signs are not required to be posted at areas or rooms containing radioactive materials for periods of less than 8 hours: Provided, that~~
 - ~~—(i) The materials are constantly attended during such periods by an individual who shall take the precautions necessary to prevent the exposure of any individual to radiation or radioactive materials in excess of the limits established in the provisions of this rule; and~~
 - ~~—(ii) Such area or room is subject to the employer's control.~~
- ~~—(8) Exemptions for radioactive materials packaged for shipment. Radioactive materials packaged and labeled in accordance with regulations of the Department of Transportation published in 49 CFR Chapter I, are exempt from the labeling and posting requirements of this rule during shipment, provided that the inside containers are labeled in accordance with the provisions of subsection (5) of this rule.~~
- ~~—(9) Instruction of personnel, posting:~~
 - ~~—(a) Employers regulated by the Nuclear Regulatory Commission shall be governed by 10 CFR Part 20 standards. Employers in a State named in paragraph (16)(c) of this rule shall be governed by the requirements of the laws and regulations of that State. All other employers shall be regulated by the following:~~
 - ~~—(b) All individuals working in or frequenting any portion of a radiation area shall be informed of the occurrence of radioactive materials or of radiation in such portions of the radiation area; shall be instructed in the safety problems associated with exposure to such materials or radiation and in precautions or devices to minimize exposure; shall be instructed in the applicable provisions of this rule for the protection of employees from exposure to radiation or radioactive materials; and shall be advised of reports of radiation exposure which employees may request pursuant to the regulations in this rule.~~
 - ~~—(c) Each employer to whom this rule applies shall post a current copy of its provisions and a copy of the operating procedures applicable to the work conspicuously in such locations as to insure that employees working in or frequenting radiation areas will observe these documents on the way to and from their place of employment, or shall keep such documents available for examination of employees upon request.~~
 - ~~—(10) Storage of radioactive materials. Radioactive materials stored in a nonradiation area shall be secured against unauthorized removal from the place of storage.~~
 - ~~—(11) Waste disposal. No employer shall dispose of radioactive material except by transfer to an authorized recipient, or in a manner approved by the Nuclear Regulatory Commission or a State named in paragraph (16)(c) of this rule.~~
 - ~~—(12) Notification of incidents:~~
 - ~~—(a) Immediate notification. Each employer shall immediately notify the Department of Public Health for employees not protected by the Nuclear Regulatory Commission by means of 10 CFR Part 20; paragraph (16)(b) of this rule or the requirements of the laws and regulations of States named in paragraph (16)(c) of this rule, by telephone or telegraph of any incident involving radiation which may have caused or threatens to cause:~~
 - ~~—(i) Exposure of the whole body of any individual of 25 rems or more of radiation; exposure of the skin of the whole body of any individual to 150 rems or more of radiation; or exposure of the feet, ankles, hands, or forearms of any individual to 375 rems or more of radiation; or~~
 - ~~—(ii) The release of radioactive material in concentrations which, if averaged over a period of 24 hours, would exceed 5,000 times the limit specified for such materials in Table II of Appendix B to 10 CFR Part 20.~~
 - ~~—(iii) A loss of 1 working week or more of the operation of any facilities affected; or~~

- ~~—(iv) Damage to property in excess of \$100,000.~~
- ~~—(b) Twenty four hour notification. Each employer shall within 24 hours following its occurrence notify the Department of Public Health for employees not protected by the Nuclear Regulatory Commission by means of 10 CFR Part 20; paragraph (16)(b) of this rule, or the requirements of the laws and regulations of states named in paragraph (16)(c) of this rule, by telephone or telegraph of any incident involving radiation which may have caused or threatens to cause:
 - ~~—(i) Exposure of the whole body of any individual to 5 rems or more of radiation; exposure of the skin of the whole body of any individual to 30 rems or more of radiation; or exposure of the feet, ankles, hands, or forearms to 75 rems or more of radiation; or~~
 - ~~—(ii) A loss of 1 day or more of the operation of any facilities; or~~
 - ~~—(iii) Damage to property in excess of \$10,000.~~~~
- ~~—(13) Reports of overexposure and excessive levels and concentrations.
 - ~~—(a) In addition to any notification required by subsection (12) of this rule each employer shall make a report in writing within 30 days to the Department of Public Health for employees not protected by the Nuclear Regulatory Commission by means of 10 CFR Part 20 of each exposure of an individual to radiation or concentrations of radioactive material in excess of any applicable limit in this rule. Each report required under this paragraph shall describe the extent of exposure of persons to radiation or to radioactive material; levels of radiation and concentration of radioactive material involved, the cause of the exposure, levels of concentrations; and corrective steps taken or planned to assure against a recurrence.~~
 - ~~—(b) In any case where an employer is required pursuant to the provisions of this subsection to report to the Department of Public Health any exposure of an individual to radiation or to concentrations of radioactive material, the employer shall also notify such individual of the nature and extent of exposure. Such notice shall be in writing and shall contain the following statement: "You should preserve this report for future reference."~~~~
- ~~—(14) Records:
 - ~~—(a) Every employer shall maintain records of the radiation exposure of all employees for whom personnel monitoring is required under subsection (4) of this rule and advise each of his employees of his individual exposure on at least an annual basis.~~
 - ~~—(b) Every employer shall maintain records in the same units used in tables in subsection (2) of this rule and Appendix B to 10 CFR Part 20.~~~~
- ~~—(15) Disclosure to former employee of individual employee's records.
 - ~~—(a) At the request of a former employee an employer shall furnish to the employee a report of the employee's exposure to radiation as shown in records maintained by the employer pursuant to paragraph (14)(a) of this rule. Such report shall be furnished within 30 days from the time the request is made, and shall cover each calendar quarter of the individual's employment involving exposure to radiation or such lesser period as may be requested by the employee. The report shall also include the results of any calculations and analysis of radioactive material deposited in the body of the employee. The report shall be in writing and contain the following statement: "You should preserve this report for future reference."~~
 - ~~—(b) The former employee's request should include appropriate identifying data, such as social security number and dates and locations of employment.~~~~
- ~~—(16) Nuclear Regulatory Commission licensees—AEC contractors operating AEC plants and facilities—AEC Agreement State licensees or registrants.
 - ~~—(a) Any employer who possesses or uses source material, by product material, or special nuclear material, as defined in the Atomic Energy Act of 1954, as amended, under a license issued by the Nuclear Regulatory Commission and in accordance with the requirements of 10 CFR Part 20 shall be deemed to be in compliance with the requirements of this rule with respect to such possession and use.~~~~

~~—(b) AEC contractors operating AEC plants and facilities: Any employer who possesses or uses source material, by product material, special nuclear material, or other radiation sources under a contract with the Nuclear Regulatory Commission for the operation of AEC plants and facilities and in accordance with the standards, procedures, and other requirements for radiation protection established by the Commission for such contract pursuant to the Atomic Energy Act of 1954, as amended (42 U.S.C. 2011 et seq.), shall be deemed to be in compliance with the requirements of this rule with respect to such possession and use.~~

~~—(c) AEC Agreement State licensees or registrants:~~

~~—(i) Atomic Energy Act sources. Any employer who possesses or uses source material, by product material, or special nuclear material, as defined in the Atomic Energy Act of 1954, as amended (42 U.S.C. 2011 et seq.), and has either registered such sources with, or is operating under a license issued by, a State which has an agreement in effect with the Nuclear Regulatory Commission pursuant to section 274(b) (42 U.S.C. 2021(b)) of the Atomic Energy Act of 1954, as amended, and in accordance with the requirements of the State's laws and regulations shall be deemed to be in compliance with the radiation requirements of this rule, insofar as his possession and use of such material is concerned, unless the Secretary of Labor, after conference with the Nuclear Regulatory Commission, shall determine that the State's program for control of these radiation sources is incompatible with the requirements of this rule. Such agreements currently are in effect only in the State of Alabama, Arkansas, California, Kansas, Kentucky, Florida, Mississippi, New Hampshire, New York, North Carolina, Texas, Tennessee, Oregon, Idaho, Arizona, Colorado, Louisiana, Nebraska, Washington, Maryland, North Dakota, South Carolina, and Georgia.~~

~~—(ii) Other sources. Any employer who possesses or uses radiation sources other than source material, byproduct material, or special nuclear material, as defined in the Atomic Energy Act of 1954, as amended (42 U.S.C. 2011 et seq.), and has either registered such sources with, or is operating under a license issued by a State which has an agreement in effect with the Nuclear Regulatory Commission pursuant to section 274(b) (42 U.S.C. 2021(b)) of the Atomic Energy Act of 1954, as amended, and in accordance with the requirements of that State's laws and regulations shall be deemed to be in compliance with the radiation requirements of this rule, insofar as his possession and use of such material is concerned, provided the State's program for control of these radiation sources is the subject of a currently effective determination by the United States Department of Labor that such program is compatible with the requirements of this rule. Such determinations currently are in effect only in the States of Alabama, Arkansas, California, Kansas, Kentucky, Florida, Mississippi, New Hampshire, New York, North Carolina, Texas, Tennessee, Oregon, Idaho, Arizona, Colorado, Louisiana, Nebraska, Washington, Maryland, North Dakota, South Carolina, and Georgia. [1910.96]~~

~~—(17) For machine rooms in pulp, paper and paperboard mills covered by Rule 5001: Radiation. Special standards regarding the use of radiation equipment shall be posted and followed as required by this rule. [1910.261(k)(32)]~~

~~—(18) X ray control in welding, cutting, and brazing, covered by Rule 3240.~~

~~—(a) Transmission pipeline: X-ray inspection. The use of X-rays and radioactive isotopes for the inspection of welded pipeline joints shall be carried out in conformance with the American National Standard Safety Standard for Non-Medical X-ray and Sealed Gamma-Ray Sources, ANSI Z54.1-1963. [1910.252(g)(1)(vii)]~~

~~—(b) Mechanical piping systems: X-ray inspection. The use of X-rays and radioactive isotopes for the inspection of welded piping joints shall be in conformance with the American National Standard and Safety Standard for Non-Medical X-ray and Sealed Gamma-Ray Sources. ANSI Z54.1-1963. [1910.252(g)(2)(ii)]~~

**ENROLLED SENATE AND HOUSE BILLS
SIGNED INTO LAW OR VETOED
(2009 SESSION)**

Mich. Const. Art. IV, §33 provides: “Every bill passed by the legislature shall be presented to the governor before it becomes law, and the governor shall have 14 days measured in hours and minutes from the time of presentation in which to consider it. If he approves, he shall within that time sign and file it with the secretary of state and it shall become law . . . If he does not approve, and the legislature has within that time finally adjourned the session at which the bill was passed, it shall not become law. If he disapproves . . . he shall return it within such 14-day period with his objections, to the house in which it originated.”

Mich. Const. Art. IV, §27, further provides: “No act shall take effect until the expiration of 90 days from the end of the session at which it was passed, but the legislature may give immediate effect to acts by a two-thirds vote of the members elected to and serving in each house.”

MCL 24.208 states in part:

“Sec. 8. (1) The State Office of Administrative Hearings and Rules shall publish the Michigan register at least once each month. The Michigan register shall contain all of the following:

* * *

(b) On a cumulative basis, the numbers and subject matter of the enrolled senate and house bills signed into law by the governor during the calendar year and the corresponding public act numbers.

(c) On a cumulative basis, the numbers and subject matter of the enrolled senate and house bills vetoed by the governor during the calendar year.”

**ENROLLED SENATE AND HOUSE BILLS
SIGNED INTO LAW OR VETOED
(2009 SESSION)**

Public Act No.	Enrolled House Bill	Enrolled Senate Bill	I.E. * Yes / No	Governor Approved Date	Filed Date	Effective Date	Subject
1	4239		Yes	3/11	3/11	3/11/09	Employment security; administration; persons to whom agency information may be disclosed and assessment of solvency tax; revise. (Rep. B. Constan)
2		202	Yes	3/26	3/27	3/27/09	Liquor; retail sales; prohibition of ownership or marketing for certain entities; revise and clarify. (Sen. A. Sanborn)
3	4582		Yes	3/31	3/31	3/31/09	Appropriations; supplemental; multidepartment supplemental for 2008-2009 fiscal year; provide for. (Rep. L. Gonzales)
4		190	Yes	4/2	4/2	4/2/09	Communications; video services; dispute resolution process; provide for. (Sen. S. Thomas)
5	4515		Yes	4/6	4/6	4/6/09 #	Michigan business tax; credit; number of credits for certain cell manufacturing facilities; increase. (Rep. D. Slavens)
6		319	Yes	4/6	4/6	4/6/09 #	Michigan business tax; credit; credit available for certain cell manufacturing facilities; increase, and revise composition of review board. (Sen. J. Pappageorge)
7	4258		Yes	4/6	4/7	4/7/09	Appropriations; supplemental; multidepartment supplemental for fiscal year ending September 30, 2009; provide for. (Rep. G. Cushingberry)

* - I.E. means Legislature voted to give the Act immediate effect.

** - Act takes effect on the 91st day after *sine die* adjournment of the Legislature.

*** - See Act for applicable effective date.

+ - Line item veto

- Tie bar

Public Act No.	Enrolled House Bill	Enrolled Senate Bill	I.E. * Yes / No	Governor Approved Date	Filed Date	Effective Date	Subject
8		098	Yes	4/9	4/9	1/1/08 #	Michigan business tax; estimated payments; clarification during transition period for penalties associated with the payment of estimated taxes for the 2008 tax year; provide for. (Sen. J. Pappageorge)
9	4496		Yes	4/9	4/9	1/1/08 #	Michigan business tax; estimated payments; clarification during transition period for penalties associated with the payment of estimated taxes for the 2008 tax year; provide for. (Rep. S. Roberts)
10	4096		Yes	4/9	4/9	4/9/09 #	Criminal procedure; warrants; issuance of certain search warrants; revise. (Rep. R. LeBlanc)
11		188	Yes	4/9	4/9	4/9/09 #	Criminal procedure; warrants; issuance of certain search warrants; revise. (Sen. A. Cropsey)
12		379	Yes	4/9	4/9	4/9/09 #	Financial institutions; loan officers; mortgage loan officer registration; require for consumer financial service companies. (Sen. D. Olshove)
13		380	Yes	4/9	4/9	4/9/09 #	Financial institutions; loan officers; registration of consumer financial services company mortgage loan officers; allow under mortgage brokers, lenders, and servicers licensing act. (Sen. G. Van Woerkom)

* - I.E. means Legislature voted to give the Act immediate effect.

** - Act takes effect on the 91st day after *sine die* adjournment of the Legislature.

*** - See Act for applicable effective date.

+ - Line item veto

- Tie bar

Public Act No.	Enrolled House Bill	Enrolled Senate Bill	I.E. * Yes / No	Governor Approved Date	Filed Date	Effective Date	Subject
14		381	Yes	4/9	4/9	4/9/09 #	Financial institutions; loan officers; registration of consumer financial services company mortgage loan officers; allow under secondary mortgage act. (Sen. B. Hardiman)
15		227	Yes	4/9	4/9	4/9/09	Children; guardians; guardianship assistance act; clarify. (Sen. I. Clark-Coleman)
16	4045		Yes	4/9	4/9	4/9/09	Economic development; neighborhood enterprise zones; requirements for filing certain applications for a neighborhood enterprise zone; revise. (Rep. B. Scott)
17	4159		Yes	4/9	4/9	4/9/09	Children; adoption; adoption support subsidy; modify to bring into compliance with federal IV-E standards. (Rep. A. Smith)
18	4668		Yes	4/13	4/13	4/13/09	Employment security; benefits; nonchargeable benefits; modify. (Rep. S. Lindberg)
19		399	Yes	4/13	4/13	4/13/09	Employment security; benefits; provision relating to extended benefits; modify. (Sen. J. Allen)
20	4669		Yes	4/13	4/13	4/13/09	Employment security; benefits; training benefits charged to nonchargeable account; clarify. (Rep. L. Liss)
21		195	Yes	5/5	5/5	5/5/09 #	Local government; financing; investment in certain certificates of deposit; include credit unions. (Sen. T. Stamas)

* - I.E. means Legislature voted to give the Act immediate effect.

** - Act takes effect on the 91st day after *sine die* adjournment of the Legislature.

*** - See Act for applicable effective date.

+ - Line item veto

- Tie bar

Public Act No.	Enrolled House Bill	Enrolled Senate Bill	I.E. * Yes / No	Governor Approved Date	Filed Date	Effective Date	Subject
22	4397		Yes	5/5	5/5	5/5/09 #	Education; financing; investment of certain deposit; include credit unions. (Rep. J. Mayes)
23		322	Yes	5/7	5/7	5/7/09	Appropriations; supplemental; projects administered by departments of natural resources and military affairs; provide funding. (Sen. M. McManus)
24	4309		Yes	5/12	5/12	5/12/09	Appropriations; zero budget; supplemental appropriations; provide for fiscal year 2008-2009. (Rep. G. Cushingberry)
25	4715		Yes	5/12	5/12	5/12/09	State financing and management; funds; investment of money in state lottery fund; modify. (Rep. B. Johnson)
26		466	Yes	5/12	5/12	5/12/09	Michigan business tax; credit; number of credits available for certain cell manufacturing facilities and cap on credit for certain research and development expenses; increase. (Sen. W. Kuipers)
27		145	Yes	5/20	5/21	7/1/09 #	Criminal procedure; sentencing; restitution to include recovery for replacement value if fair market value is impractical or impossible to ascertain; allow. (Sen. J. Barcia)
28		146	Yes	5/20	5/21	7/1/09 #	Crime victims; restitution; recovery for replacement value if fair market value is impossible or impractical to ascertain; allow. (Sen. A. Cropsey)

* - I.E. means Legislature voted to give the Act immediate effect.

** - Act takes effect on the 91st day after *sine die* adjournment of the Legislature.

*** - See Act for applicable effective date.

+ - Line item veto

- Tie bar

Public Act No.	Enrolled House Bill	Enrolled Senate Bill	I.E. * Yes / No	Governor Approved Date	Filed Date	Effective Date	Subject
29	4453		Yes	5/20	5/21	7/5/09 #	Civil procedure; foreclosure; foreclosure by advertisement; prohibit unless requirements of mortgage negotiation program have been completed. (Rep. S. Jackson)
30	4454		Yes	5/20	5/21	7/5/09 #	Civil procedure; foreclosure; negotiation program for mortgages of certain residential property that are in default; create. (Rep. A. Coulouris)
31	4455		Yes	5/20	5/21	7/5/09 #	Civil procedure; foreclosure; foreclosure by advertisement; prohibit if borrower qualifies for modification of mortgage loan. (Rep. B. Johnson)
32	4781		Yes	6/4	6/4	12/1/09 #	Trade; vehicles; recreational vehicle dealers; allow separate licensure as dealers under Michigan vehicle code. (Rep. J. Sheltrown)
33		363	Yes	6/4	6/4	12/1/09 #	Trade; vehicles; recreational vehicle manufacturers, wholesalers, warrantors, and dealers; regulate. (Sen. J. Allen)
34		409	Yes	6/4	6/4	6/4/09	Natural resources; fishing; period of validity of licenses; allow natural resources commission to modify. (Sen. J. Barcia)
35	4145		Yes	6/4	6/4	6/4/09	Natural resources; inland lakes; establishment of special rules on lakes; repeal sunset. (Rep. G. Hansen)

* - I.E. means Legislature voted to give the Act immediate effect.

** - Act takes effect on the 91st day after *sine die* adjournment of the Legislature.

*** - See Act for applicable effective date.

+ - Line item veto

- Tie bar

Public Act No.	Enrolled House Bill	Enrolled Senate Bill	I.E. * Yes / No	Governor Approved Date	Filed Date	Effective Date	Subject
36		010	Yes	6/4	6/4	6/4/09	Natural resources; wildlife; taking of raptors for falconry; require department to issue an order establishing season. (Sen. R. Richardville)
37	4224		Yes	6/4	6/4	6/4/09	Traffic control; traffic regulation; prohibition for a truck trailer to tow both a slasher and saw unit; eliminate. (Rep. K. Ebli)
38	4308		Yes	6/9	6/9	6/9/09	Appropriations; zero budget; supplemental appropriations; provide for fiscal year 2008-2009. (Rep. G. Cushingberry)
39	4830		Yes	6/12	6/12	6/12/09	Counties; boards and commissions; powers and duties of county road commissioners; allow to be reorganized by charter counties under certain circumstances. (Rep. F. Miller)
40		096	Yes	6/18	6/18	6/18/09	Occupations; individual licensing and regulation; rules for certain educational programs; allow adoption by the department. (Sen. P. Birkholz)
41		108	Yes	6/18	6/18	6/18/09	Gaming; bingo and charitable gaming; eligibility for charitable gaming licenses; expand to include an auxiliary of a national veterans' organization. (Sen. R. Kahn)
42		383	Yes	6/18	6/18	4/1/10 #	Probate; trusts; conflicts between chapter 81 of the revised statutes of 1846 and the Michigan trust code; resolve. (Sen. W. Kuipers)

* - I.E. means Legislature voted to give the Act immediate effect.

** - Act takes effect on the 91st day after *sine die* adjournment of the Legislature.

*** - See Act for applicable effective date.

+ - Line item veto

- Tie bar

Public Act No.	Enrolled House Bill	Enrolled Senate Bill	I.E. * Yes / No	Governor Approved Date	Filed Date	Effective Date	Subject
43		384	Yes	6/18	6/18	4/1/10 #	Probate; trusts; conflicts between chapter 63 of the revised statutes of 1846 and the Michigan trust code; resolve. (Sen. W. Kuipers)
44		385	Yes	6/18	6/18	4/1/10 #	Probate; trusts; Michigan uniform fraudulent transfer act; amend to conform to Michigan trust code. (Sen. H. Clarke)
45		386	Yes	6/18	6/18	4/1/10 #	Probate; trusts; powers of appointment act of 1967; amend to conform to Michigan trust code. (Sen. W. Kuipers)
46		387	Yes	6/18	6/18	4/1/10 #	Probate; trusts; Michigan trust code; enact. (Sen. A. Cropsey)
47	4286		Yes	6/18	6/18	6/18/09	Natural resources; hunting; promotion of; provide for on department of natural resources controlled land. (Rep. J. Nerat)
48		432	Yes	6/18	6/18	6/18/09	Liquor; licenses; license to serve alcohol on certain premises of Wayne state university; allow under certain circumstances. (Sen. H. Clarke)
49	4479		Yes	6/18	6/18	6/18/09	Property tax; other; county board of commissioners meeting in October; revise meeting date. (Rep. V. Barnett)
50		416	Yes	6/18	6/18	6/18/09	State financing and management; bonds; interest rates for school loans; revise. (Sen. M. Switalski)

* - I.E. means Legislature voted to give the Act immediate effect.

** - Act takes effect on the 91st day after *sine die* adjournment of the Legislature.

*** - See Act for applicable effective date.

+ - Line item veto

- Tie bar

Public Act No.	Enrolled House Bill	Enrolled Senate Bill	I.E. * Yes / No	Governor Approved Date	Filed Date	Effective Date	Subject
51		280	Yes	6/23	6/23	9/21/09 #	Natural resources; nonnative species; restricted and prohibited species lists; revise. (Sen. G. Van Woerkom)
52	4579		Yes	6/23	6/23	9/21/09 #	Natural resources; nonnative species; restricted and prohibited species lists; authorize departments of agriculture and natural resources to revise, and make sanctions applicable to additional species. (Rep. R. Warren)
53	4930		Yes	6/23	6/23	6/11/09	Sales tax; exemptions; tax incentive for sale of aircraft and aircraft components manufactured in Michigan; provide for. (Rep. K. Segal)
54		624	Yes	6/23	6/23	6/11/09	Use tax; exemptions; tax incentive for sale of aircraft and aircraft components manufactured in Michigan; provide for. (Sen. J. Allen)

* - I.E. means Legislature voted to give the Act immediate effect.

** - Act takes effect on the 91st day after *sine die* adjournment of the Legislature.

*** - See Act for applicable effective date.

+ - Line item veto

- Tie bar

**MICHIGAN ADMINISTRATIVE CODE TABLE
(2009 SESSION)**

MCL 24.208 states in part:

“Sec. 8. (1) The State Office of Administrative Hearings and Rules shall publish the Michigan register at least once each month. The Michigan register shall contain all of the following:

* * *

(i) Other official information considered necessary or appropriate by the State Office of Administrative Hearings and Rules.”

The following table cites administrative rules promulgated during the year 2000, and indicates the effect of these rules on the Michigan Administrative Code (1979 ed.).

**MICHIGAN ADMINISTRATIVE CODE TABLE
(2009 RULE FILINGS)**

R Number	Action	2009 MR Issue	R Number	Action	2009 MR Issue	R Number	Action	2009 MR Issue
29.501	A	11	38.1671	A	11	209.24	*	4
29.501a	A	11	38.1672	A	11	209.25	*	4
29.502	A	11	38.1673	A	11	209.26	*	4
29.502a	A	11	38.1674	A	11	209.28	*	4
29.502b	A	11	38.1675	A	11	209.31	A	4
29.503	A	11	38.1676	A	11	209.32	A	4
29.504	A	11	38.1677	A	11	209.33	A	4
29.505	A	11	38.1678	A	11	209.34	A	4
29.506	A	11	38.1679	A	11	209.35	R	4
29.506a	A	11	38.1680	A	11	209.36	R	4
29.507	A	11	38.1681	A	11	209.37	A	4
29.507a	A	11	38.1682	A	11	209.38	A	4
29.508	A	11	38.1683	A	11	209.41	*	4
29.509	A	11	38.1684	A	11	209.42	*	4
29.510	A	11	38.1685	A	11	209.43	*	4
35.651	R	9	38.1686	A	11	209.44	*	4
35.652	R	9	125.190	*	8	209.51	*	4
35.652a	R	9	125.191	*	8	209.52	*	4
35.653	R	9	125.192	*	8	209.53	*	4
35.654	R	9	125.193	*	8	209.54	*	4
38.1201	R	10	125.194	*	8	209.55	*	4
38.1203	R	10	125.195	*	8	209.56	*	4
38.1204	R	10	125.196	*	8	209.61	R	4
38.1207	R	10	125.197	*	8	209.62	R	4
38.1371	A	10	125.198	A	8	209.63	A	4
38.1372	A	10	209.1	*	4	209.64	A	4
38.1373	A	10	209.3	R	4	209.65	A	4
38.1374	A	10	209.5	R	4	209.66	A	4
38.1375	A	10	209.7	*	4	209.67	A	4
38.1376	A	10	209.8	*	4	209.68	A	4
38.1377	A	10	209.11	R	4	209.71	R	4
38.1378	A	10	209.13	*	4	209.72	R	4
38.1379	A	10	209.14	R	4	209.73	R	4
38.1380	A	10	209.15	R	4	209.74	R	4
38.1381	A	10	209.16	*	4	209.75	R	4
38.1382	A	10	209.17	R	4	209.76	A	4
38.1383	A	10	209.18	R	4	209.81	A	4
38.1384	A	10	209.19	*	4	209.91	A	4
38.1385	A	10	209.21	R	4	209.101	A	4
38.1386	A	10	209.23	R	4	209.111	A	4

(* Amendment to Rule, A Added Rule, N New Rule, R Rescinded Rule)

2009 MR 11 – July 1, 2009

R Number	Action	2009 MR Issue	R Number	Action	2009 MR Issue	R Number	Action	2009 MR Issue
285.561.1	*	10	333.127	A	6	339.203b	A	9
285.561.2	*	10	333.129	A	6	339.203c	A	9
285.561.3	*	10	333.131	A	6	339.203d	A	9
285.561.4	*	10	333.133	A	6	339.204	*	9
285.561.5	*	10	336.1801	*	10	339.205	*	9
285.561.6	*	10	336.1802a	*	10	339.205a	A	9
285.561.7	*	10	336.1803	*	10	339.206	*	9
285.561.8	*	10	336.1821	*	10	339.206a	A	9
285.561.9	*	10	336.1822	*	10	339.207	*	9
285.561.10	*	10	336.1823	*	10	339.210	A	9
299.1021	*	7	336.1830	*	10	339.211	*	9
299.1022	*	7	336.1831	*	10	339.213	*	9
299.1023	*	7	336.1832	*	10	339.215	*	9
299.1024	*	7	336.1833	*	10	339.217	*	9
299.1025	*	7	338.2511	A	9	339.219	*	9
299.1026	*	7	338.7001	*	9	339.221	R	9
299.1027	*	7	338.7001a	A	9	339.223	*	9
299.1028	*	7	338.7002	*	9	339.223a	A	9
322.55.1	A	9	338.7003	A	9	339.225	*	9
325.161	*	5	338.7101	*	9	339.226	A	9
325.163	*	5	338.7102	*	9	339.229	*	9
325.165	*	5	338.7103	*	9	339.230	A	9
325.166	*	5	338.7104	*	9	339.231	*	9
325.168	*	5	338.7105	*	9	339.232	A	9
330.7001	*	7	338.7107	*	9	339.233	*	9
330.7199	*	7	338.7107a	A	9	339.234	A	9
330.7243	*	7	338.7107b	A	9	339.234a	A	9
333.101	A	6	338.7108	R	9	339.235	*	9
333.103	A	6	338.7110	*	9	339.235a	A	9
333.105	A	6	338.7111	A	9	339.237	*	9
333.107	A	6	338.7112	A	9	339.243	*	9
333.109	A	6	338.7114	A	9	339.245	*	9
333.111	A	6	338.7113	A	9	339.246	A	9
333.113	A	6	339.101	*	9	339.246a	A	9
333.115	A	6	339.103	A	9	339.249	*	9
333.117	A	6	339.201	*	9	339.251	*	9
333.119	A	6	339.202	*	9	339.253	*	9
333.121	A	6	339.202a	A	9	339.255	*	9
333.123	A	6	339.203	*	9	339.257	*	9
333.125	A	6	339.203a	A	9	339.259	*	9

* Amendment to Rule, A Added Rule, N New Rule, R Rescinded Rule)

2009 MR 11 – July 1, 2009

R Number	Action	2009 MR Issue	R Number	Action	2009 MR Issue	R Number	Action	2009 MR Issue
339.261	*	9	397.72	A	6	400.11125	*	7
339.265	*	9	397.81	A	6	400.11127	*	7
339.267	*	9	397.82	A	6	400.11131	*	7
339.269	*	9	397.83	A	6	400.11133	*	7
339.271	A	9	397.84	A	6	400.11135	R	7
339.303	*	9	397.85	A	6	400.11137	R	7
339.403	*	9	397.91	A	6	400.11139	R	7
340.1721a	A	7	397.92	A	6	400.11141	R	7
340.1721e	A	7	400.1901	*	7	400.11143	*	7
340.1851	A	7	400.1902	*	7	400.11145	*	7
340.1852	A	7	400.1903	*	7	400.11146	A	7
340.1853	A	7	400.1904	*	7	400.11147	*	7
340.1854	A	7	400.1905	*	7	400.11149	*	7
340.1855	A	7	400.1907	*	7	400.11201	*	7
390.1901	A	9	400.1914	*	7	400.11203	*	7
390.1902	A	9	400.1915	*	7	400.11205	*	7
390.1903	A	9	400.1916	*	7	400.11207	*	7
390.1904	A	9	400.1917	*	7	400.11208	A	7
390.1905	A	9	400.1921	*	7	400.11209	*	7
390.1906	A	9	400.1931	*	7	400.11211	*	7
390.1907	A	9	400.1932	*	7	400.11213	*	7
390.1908	A	9	400.1934	*	7	400.11215	*	7
397.01	A	6	400.1941	*	7	400.11217	*	7
397.02	A	6	400.1942	*	7	400.11219	*	7
397.03	A	6	400.1943	*	7	400.11221	*	7
397.04	A	6	400.1944	*	7	400.11224	A	7
397.05	A	6	400.1951	*	7	400.11227	*	7
397.21	A	6	400.1952	*	7	400.11302	A	7
397.22	A	6	400.11101	*	7	400.11305	R	7
397.31	A	6	400.11102	*	7	400.11319	*	7
397.41	A	6	400.11103	*	7	400.11401	A	7
397.42	A	6	400.11105	*	7	400.11403	A	7
397.43	A	6	400.11106	*	7	400.11405	A	7
397.44	A	6	400.11109	*	7	400.11407	A	7
397.45	A	6	400.11113	*	7	400.11409	A	7
397.46	A	6	400.11115	*	7	400.11411	A	7
397.51	A	6	400.11119	*	7	400.11413	A	7
397.61	A	6	400.11121	*	7	408.4012	*	10
397.62	A	6	400.11122	A	7	408.4024	*	10
397.71	A	6	400.11123	*	7	408.4025	*	10

(* Amendment to Rule, A Added Rule, N New Rule, R Rescinded Rule)

2009 MR 11 – July 1, 2009

R Number	Action	2009 MR Issue	R Number	Action	2009 MR Issue	R Number	Action	2009 MR Issue
408.4026	*	10	408.42931	A	6	460.642	A	10
408.4027	*	10	408.42934	A	6	460.644	A	10
408.4031	*	10	408.42937	A	6	460.646	A	10
408.4032	*	10	408.42940	A	6	460.648	A	10
408.4033	*	10	408.42943	A	6	460.650	A	10
408.4038	*	10	431.1245	*	9	460.652	A	10
408.4047	*	10	431.3055	*	9	460.654	A	10
408.4057	*	10	431.3075	*	9	460.656	A	10
408.4058	*	10	431.3295	*	9	460.20101	*	8
408.4087	*	10	431.1301	*	4	460.20302	*	8
408.4109	*	10	431.3090	*	4	460.20304	*	8
408.4114	*	10	431.4205	*	4	460.20309	*	8
408.4121	*	10	432.5	*	5	460.20320	R	8
408.4127	*	10	432.16	*	5	460.20321	R	8
408.4171	*	10	432.18	*	5	460.20326	*	8
408.4186	R	10	460.481	R	10	460.20402	*	8
408.4193	*	10	460.482	R	10	460.20405	*	8
408.4195	*	10	460.483	R	10	460.20407	*	8
408.4197	*	10	460.484	R	10	460.20408	*	8
408.4507	*	10	460.485	R	10	460.20425	*	8
408.4701	*	10	460.486	R	10	460.20430	*	8
408.10122	*	10	460.487	R	10	460.20602	*	8
408.10123	*	10	460.488	R	10	460.20604	*	8
408.10126	*	10	460.489	R	10	460.20605	*	8
408.10127	*	10	460.601a	A	10	460.20606	*	8
408.10128	*	10	460.601b	A	10			
408.10129	*	10	460.602	A	10			
408.10142	*	10	460.604	A	10			
408.10143	*	10	460.606	A	10			
408.10155	*	10	460.608	A	10			
408.42901	A	6	460.610	A	10			
408.42904	A	6	460.612	A	10			
408.42907	A	6	460.615	A	10			
408.42910	A	6	460.618	A	10			
408.42913	A	6	460.620	A	10			
408.42916	A	6	460.622	A	10			
408.42919	A	6	460.624	A	10			
408.42922	A	6	460.626	A	10			
408.42925	A	6	460.628	A	10			
408.42928	A	6	460.640	A	10			

(* Amendment to Rule, A Added Rule, N New Rule, R Rescinded Rule)

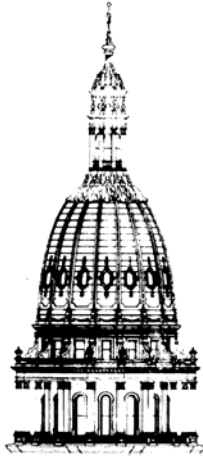

**CUMULATIVE
INDEX**

A

ARICULTURE, DEPARTMENT OF

Office of the Racing Commission General Rules (2009-9)

Reg. No 561 Dispensing Facility Vapor Pressure (2009-10)

Reg. No 570 Food Establishment Manger Certification (2009-10*)

ATTORNEY GENERAL, DEPARTMENT OF

Opinions

Legality of radio-controlled fishing devices under MCL 324.48703(1)

OAG 7222 (2009-1)

Legal effect of the Department of Environmental Quality's operational memoranda

OAG 7223 (2009-1)

Governor's Authority to Direct the Department of Environmental Quality To Impose Certain Requirements in the Processing of Applications for Air Emissions Permits for Coal-fired Power Plants

OAG No. 7224 (2009-5)

Force and Effect of Gubernatorial Statements Made in Line Item Veto Transmittal Letters

OAG No. 7225 (2009-5)

Whether a Person Serving as a Township Supervisor and City Police Hold Incompatible Offices

OAG No. 7226 (2009-5)

Legality of proxy voting under Open Meetings Act

OAG Opinion No. 7226 (2009-6)

* Proposed Rules

Application of the Sex Offenders Registration Act's Student Safety Zone Exception to Prisoners

OAG Opinion No. 7228 (2009-7)

Issues relating to the intentional sinking of a vessel to expand recreational Diving opportunities on the Great Lakes bottomlands

OAG Opinion No. 7229 (2009-8)

Voting rights of members of a summer resort owners corporation Created under 1929 PA 137.

OAG Opinion No. 7230 (2009-10)

Responsibility for costs associated with mental health treatment Provided to inmates at county jails

OAG Opinion No. 7231 (2009-10)

Incompatibility of offices of general law township trustee and fire chief Of a jointly administered fire department

OAG Opinion No. 7232 (2009-10)

C

COMMUNITY HEALTH, DEPARTMENT OF

Communicable and Related Diseases (2009-9*)

General Rules (2009-9)

General Rules (2009-9)

Michigan Care Improvement Registry (2009-5)

Michigan Medical Marihuana (2009-6)

Psychology Rules (2009-9)

Reporting of Non Suicidal, Non Medicinal Chemical Poisonings (2009-7*)

State Trauma Systems (2009-8*)

E

EDUCATION, DEPARTMENT OF

Special Education Programs and Services (2009-7)

ENERGY, LABOR & ECONOMIC GROWTH, DEPARTMENT OF

Corrections

Boiler Rules (2009-10)

Boiler Rules (2009-10)

Development Program (2009-8)

Electric Interconnection and Net Metering Standards (2009-10)

Fire Inspector Certification (2009-11)

Gas Safety (2009-8)

Insurance Policy Forms - Nonconforming Clause (2009-9*)

Judges Retirement Board – General Hearing Rules (2009-3*)

Part 1 a. Abrasive Wheels (2009-10)

Part 9 Michigan Housing and Community Development Fund, Michigan Housing and Community

Part 8 Electrical Code (2009-9*)

Part 29, Communication Towers (2009-6)

Part 381 Ionizing Radiation (2009-11*)

Property and Casualty Reserves – Actuarial Opinion (2009-7*)
Public School Retirement Board – General Hearing Rules (2009-10)
State Police Retirement Board – General Hearing Rules (2009-11)
State Retirement Board – General Hearing Rules (2009-11*)
Workers’ Compensation Health Care Services Rules (2009-5*)
Unarmed Combat Rules (2009-9)

ENVIRONMENTAL QUALITY, DEPARTMENT OF

Part. 8 Emission Limitations and Prohibitions – Oxides of Nitrogen (2009-10)
Supplying Water to the Public (2009-9*)

EXECUTIVE OFFICE

Executive Reorganization

2009 EO’s

- No. 1 (2009-2)
- No. 2 (2009-3)
- No. 3 (2009-3)
- No. 4 (2009-3)
- No. 5 (2009-3)
- No. 6 (2009-5)
- No. 7 (2009-5)
- No. 8 (2009-5)
- No. 9 (2009-5)
- No. 10 (2009-5)
- No. 11 (2009-5)
- No. 12 (2009-5)
- No. 13 (2009-5)
- No. 14 (2009-5)
- No. 15 (2009-5)
- No. 16 (2009-6)
- No. 17 (2009-6)
- No. 18 (2009-6)
- No. 19 (2009-6)
- No. 20 (2009-6)
- No. 21 (2009-7)
- No. 22 (2009-8)
- No. 23 (2009-10)
- No. 24 (2009-10)
- No. 25 (2009-10)
- No. 26 (2009-10)
- No. 27 (2009-10)
- No. 28 (2009-10)
- No. 29 (2009-10)
- No. 30 (2009-10)
- No. 31 (2009-10)
- No. 32 (2009-10)
- No. 33 (2009-10)

* Proposed Rules

No. 34 (2009-10)

No. 35 (2009-10)

H

HISTORY ARTS AND LIBRARIES, DEPARTMENT OF

State Aid Rules (2009-6)

HUMAN SERVICES, DEPARTMENT OF

Corrections

Adult Foster Care Family Homes and Licensing Rules (2009-6)

Children's and Adult Foster Care Camps (2009-7)

Licensing Rules for Family and Group Child Care Homes (2009-7)

N

NATURAL RESOURCES, DEPARTMENT OF

Threaten and Endanger Species (2009-7)

Wilderness and Natural Areas (2009-9)

S

STATE POLICE, DEPARTMENT OF

Criminal Justice Information Systems (2009-2*)

T

TRANSPORTATION, DEPARTMENT OF

Prequalification of Construction Contractors (2009-10*)

TREASURY, DEPARTMENT OF

Children of Veterans Tuition Grant Program (2009-9)

Lottery Rules (2009-5)