

2015 Michigan Residential Code Errors and Conflicts

The following are errors and conflicts that have been identified at this point. The Bureau of Construction Codes has reviewed these issues. The Director of Department of Licensing and Regulatory Affairs has delegated the authority to make, and has approved, the following determinations which are binding on all enforcing agencies.

Stair Geometry

In the Michigan Residential Code Section R311.7.4.1 Riser height and Section R311.7.4.2 Tread depth are the correct requirements for stair geometry and they are the promulgated state rules consistent with MCL 125.1513d. These provisions shall replace the provisions in Sections R311.7.5.1 and R311.7.5.2 respectively; however the exceptions in R311.7.5.1 are still valid.

Vapor Retarders

There are 2 sections on vapor retarders in the 2015 Michigan Residential Code, R601.3 and R702.7. It has been determined by the department that section R601.3 is the section that is to be enforced by all enforcing agencies.

Figure R507.2.1(2) was obviously corrupted during the publication of the rules and was not noticed until it was published by the International Code Council. The figure that must be used by all enforcing agencies is now provided.

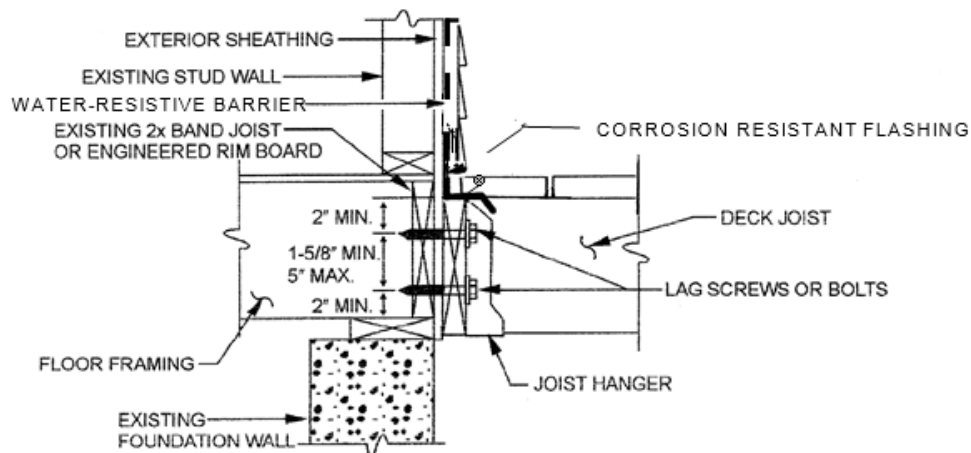

For SI: 1 inch = 25.4 mm.

FIGURE R507.2.1(2)
PLACEMENT OF LAG SCREWS AND BOLTS IN BAND JOISTS

Carbon Monoxide Detector Location

MRC section R315 does not provide the location of the carbon monoxide detectors. The location of these devices is found in the 1972 PA 230 section 4f, MCL 125.1504f: "A carbon monoxide device shall be located in the vicinity of the bedrooms, which may include 1 device capable of detecting carbon monoxide near all adjacent bedrooms; in areas within the dwelling adjacent to an attached garage; and in areas adjacent to any fuel-burning appliances." They are to be installed in accordance with manufacturer's recommendations and should not be placed within fifteen feet of fuel-burning heating or cooking appliances such as gas stoves, furnaces or fireplaces or in or near very humid areas such as bathrooms.

Duct Construction

The Michigan Residential Code (MRC) Sections N1103.2.3 and M1601.1.1 conflict regarding the use of building framing cavities for plenums. To resolve the conflict we look at the definition of "cost effective" in MCL 125.1502a(p), and MCL 125.1504(3)(f) and (g).

MCL 125.1504a(p) states:

(p) "Cost-effective", in reference to section 4(3)(f) and (g), means, using the existing energy efficiency standards and requirements as the base of comparison, the economic benefits of the proposed energy efficiency standards and requirements will exceed the economic costs of the requirements of the proposed rules based upon an incremental multiyear analysis that meets all of the following requirements:

(i) Considers the perspective of a typical first-time home buyer.

(ii) Considers benefits and costs over a 7-year time period.

(iii) Does not assume fuel price increases in excess of the assumed general rate of inflation.

(iv) Ensures that the buyer of a home who would qualify to purchase the home before the addition of the energy efficient standards will still qualify to purchase the same home after the additional cost of the energy-saving construction features."

MCL 125.1504(3)(f) and (g) state:

"(3) The code shall be designed to effectuate the general purposes of this act and the following objectives and standards:

(f) To provide standards and requirements for cost-effective energy efficiency that will be effective April 1, 1997.

(g) Upon periodic review, to continue to seek ever-improving, cost-effective energy efficiencies."

The conflict is resolved in favor of M1601.1.1 as MRC Section M1601 is the definitive section on duct construction. This decision is based on MRC Section R102.1 (Where there is a conflict between a general requirement and a specific requirement, the specific requirement shall be applicable.) and that Section N1103.2.3 has not been shown to meet the definition of cost effective.

Combustible Insulation

Section R302.13 is the language that is promulgated by the department and is the language that must be used. Section R302.14 shall be treated as if it was deleted which was the intent.

Roof Loading Data Sheet

Figure 802.10.1 under Exposure Factor C the designation should be B C and D to be consistent with the ASCE 7-10 standard. The text for the exposures is correct but when A was deleted to be consistent with standard an auto correct function relabeled the remaining exposures A, B and C. This was not caught before publication. If the text is used for providing the requested information and A, B and C designation replaced with B, C and D respectively the information will be correct.