



# Geotechnical Manual



**Bureau of Bridges & Structures**  
**November 2019 - Revised February 2026**



# ***Engineering Manual Preamble***

This manual provides guidance to administrative, engineering, and technical staff. Engineering practice requires that professionals use a combination of technical skills and judgment in decision making. Engineering judgment is necessary to allow decisions to account for unique site-specific conditions and considerations to provide high-quality products, within budget, and to protect the public health, safety, and welfare. This manual provides the general operational guidelines; however, it is understood that adaptation, adjustments, and deviations are sometimes necessary. Innovation is a key foundational element to advance the state of engineering practice and develop more effective and efficient engineering solutions and materials. As such, it is essential that our engineering manuals provide a vehicle to promote, pilot, or implement technologies or practices that provide efficiencies and quality products, while maintaining the safety, health, and welfare of the public. When making significant or impactful deviations from the technical information from these guidance materials, it is expected that reasonable consultations with experts, technical committees, and/or policy setting bodies occur prior to actions within the time frames allowed. It is also expected that these consultations will eliminate any potential conflicts of interest, perceived or otherwise. Michigan Department of Transportation Leadership is committed to a culture of innovation to optimize engineering solutions.

The National Society of Professional Engineers Code of Ethics for Engineering is founded on six fundamental canons. Those canons are provided below.

Engineers, in the fulfillment of their professional duties, shall:

1. Hold paramount the safety, health, and welfare of the public.
2. Perform Services only in areas of their competence.
3. Issue public statement only in an objective and truthful manner.
4. Act for each employer or client as faithful agents or trustees.
5. Avoid deceptive acts.
6. Conduct themselves honorably, reasonably, ethically and lawfully so as to enhance the honor, reputation, and usefulness of the profession.

*Cover Photos:* Top, Left – Drilled shaft construction within cofferdam for new bridge.  
Top, Right – Existing slope failure on MDOT trunkline.  
Center, Left – Drill crew drilling with a CME 850 ATV.  
Center, Right – 16-inch diameter steel pile driving at proposed bridge abutment.  
Bottom, Left – Graphical 3D representation of aerial lidar data collected on federal highway route.  
Bottom, Right – Lab testing equipment, direct shear and triaxial testing apparatuses.

## TABLE OF CONTENTS

<b>SECTION 1 – INTRODUCTION.....</b>	<b>1</b>
<b>1.1 INTRODUCTION.....</b>	<b>1</b>
<b>SECTION 2 – GENERAL INFORMATION.....</b>	<b>2</b>
<b>2.1 ADMINISTRATIVE OR ORGANIZATIONAL STRUCTURE.....</b>	<b>2</b>
<b>2.2 PROJECT DEVELOPMENT PROCESS.....</b>	<b>2</b>
<b>2.3 GEOTECHNICAL DESIGN POLICIES AND THEIR BASIS .....</b>	<b>2</b>
2.3.1 MANUAL CHANGES .....	3
<b>2.4 GEOTECHNICAL SOFTWARE .....</b>	<b>4</b>
<b>SECTION 3 – CONSULTANT CONTRACTS .....</b>	<b>6</b>
<b>3.1 GENERAL.....</b>	<b>6</b>
<b>3.2 CONSULTANT CONTRACTING METHODS .....</b>	<b>6</b>
3.2.1 DESIGN-BID-BUILD PROJECTS.....	6
3.2.2 INNOVATIVE CONTRACTING METHODS.....	7
3.2.3 SPECIAL PROJECTS.....	7
<b>SECTION 4 – MICHIGAN GLACIAL HISTORY .....</b>	<b>8</b>
<b>4.1 FUTURE SECTION TO BE DEVELOPED.....</b>	<b>8</b>
<b>SECTION 5 – FIELD INVESTIGATION TECHNIQUES AND PROCEDURES .....</b>	<b>9</b>
<b>5.1 GENERAL.....</b>	<b>9</b>
5.1.1 REVIEW OF PROJECT REQUIREMENTS.....	9
5.1.2 REVIEW OF AVAILABLE DATA .....	9
5.1.2.1 Topographic Maps.....	9
5.1.2.2 Aerial Photographs.....	10
5.1.2.3 Geological Maps and Reports .....	10
5.1.2.4 Natural Resources Conservation Service Soil Surveys .....	10
5.1.2.5 Water Well Surveys .....	10
5.1.2.6 Existing Design Plans and Construction Records.....	10
5.1.2.7 Remote Sensing.....	11
5.1.3 SITE RECONNAISSANCE .....	11
<b>5.2 PERMITS .....</b>	<b>12</b>
<b>5.3 FIELD WORK ON PRIVATE PROPERTY .....</b>	<b>12</b>
5.3.1 RAILROAD ACCESS .....	12
5.3.2 DOCUMENTATION OF PROPERTY DAMAGE.....	13

## TABLE OF CONTENTS

<b>5.4</b>	<b>UTILITY LOCATION/NOTIFICATION.....</b>	<b>13</b>
<b>5.5</b>	<b>DRILLING SAFETY.....</b>	<b>13</b>
<b>5.6</b>	<b>DRILLING AND SAMPLING OF SOIL AND ROCK.....</b>	<b>14</b>
5.6.1	EQUIPMENT.....	14
5.6.2	DRILLING METHODS.....	14
5.6.2.1	Continuous Flight or Hand Auger Borings.....	14
5.6.2.2	Hollow-Stem Auger Borings.....	15
5.6.2.3	Rotary Drilling.....	15
5.6.2.4	Direct Push Borings (i.e., GeoProbe®).....	15
5.6.2.5	Coring.....	16
5.6.2.6	Other Drilling Methods.....	16
5.6.3	BACKFILL OF BOREHOLES.....	16
5.6.4	SOUNDINGS.....	17
5.6.5	TEST PITS AND TRENCHES.....	17
5.6.6	SAMPLING PROCEDURES.....	17
5.6.6.1	Bulk Bag Samples.....	17
5.6.6.2	Split-Barrel Sampler.....	18
5.6.6.3	Thin-Walled Undisturbed Tube Sampler.....	18
5.6.6.4	Transverse Shear Core Sampling.....	18
5.6.6.5	Rock Core Sampling.....	18
5.6.6.6	Other Sampling Methods.....	20
<b>5.7</b>	<b>GEOPHYSICAL METHODS.....</b>	<b>20</b>
5.7.1	SEISMIC REFRACTION AND REFLECTION SURVEY.....	21
5.7.2	ELECTRICAL RESISTIVITY SURVEY.....	21
5.7.3	GROUND PENETRATING RADAR (GPR).....	21
5.7.4	SURFACE WAVE METHODS (SASW AND MASW).....	22
<b>5.8</b>	<b>IN-SITU SOIL TESTING.....</b>	<b>22</b>
5.8.1	STANDARD PENETRATION TEST (SPT).....	22
5.8.2	CONE PENETROMETER TEST (CPT).....	23
5.8.3	DYNAMIC CONE PENETROMETER TEST (DCP).....	23
5.8.4	DILATOMETER TEST (DMT).....	24
5.8.5	PRESSUREMETER TEST (PMT).....	25
5.8.6	FIELD VANE TEST.....	25
5.8.7	FALLING WEIGHT DEFLECTOMETER (FWD).....	25
<b>5.9</b>	<b>FIELD INSTRUMENTATION.....</b>	<b>26</b>
5.9.1	GENERAL PURPOSE.....	26
5.9.2	INCLINOMETERS.....	27
5.9.3	SETTLEMENT INDICATORS.....	27
5.9.3.1	Settlement Plates.....	28

TABLE OF CONTENTS

5.9.3.2	Pneumatic Settlement Cell.....	28
5.9.3.3	Benchmarks and Heave Stakes .....	28
5.9.3.4	Crack Gauges .....	28
5.9.4	PIEZOMETERS .....	29
5.9.5	MONITORING WELLS.....	29
5.9.6	TILTMETERS .....	30
5.9.7	VIBRATION MONITORING .....	30
5.9.8	OTHER SPECIAL INSTRUMENTATION.....	31
5.9.9	INTERPRETATION AND REPORTING.....	31
5.9.9.1	Qualifications of Personnel .....	31
<b>5.10</b>	<b>SURVEY .....</b>	<b>31</b>
<b>5.11</b>	<b>APPENDIX 5.....</b>	<b>32</b>
5.11.1	APPENDIX 5.1 .....	32
<b>SECTION 6 – SUBSURFACE INVESTIGATION GUIDELINES.....</b>		<b>34</b>
<b>6.1</b>	<b>INTRODUCTION.....</b>	<b>34</b>
<b>6.2</b>	<b>GENERAL REQUIREMENTS .....</b>	<b>34</b>
6.2.1	SPACING AND NUMBER OF BORINGS .....	34
6.2.2	CONSULTANT GEOTECHNICAL ENGINEER.....	35
6.2.3	MISCELLANEOUS .....	35
6.2.3.1	Groundwater Observations.....	36
<b>6.3</b>	<b>GUIDELINES FOR MINIMUM EXPLORATIONS.....</b>	<b>37</b>
6.3.1	STRUCTURES.....	37
6.3.1.1	Bridges.....	37
6.3.1.2	Bridge Approach Embankments.....	38
6.3.1.3	Retaining Walls.....	38
6.3.1.4	Culverts.....	39
6.3.1.5	Overhead Sign Structures.....	40
6.3.1.6	High Mast Lighting.....	40
6.3.1.7	Strain Poles.....	40
6.3.1.8	Mast Arms .....	41
6.3.1.9	Dynamic Message Signs (DMS), Closed Circuit Television Camera (CCTV) Poles & Environmental Sensor Station (ESS) Poles .....	41
6.3.1.10	Cable Barriers .....	41
6.3.1.11	Noise Barrier Walls.....	41
6.3.1.12	Buildings .....	42
6.3.1.13	Excavations.....	42
6.3.1.14	Tunnels .....	42
6.3.1.15	Boardwalks .....	43
6.3.1.16	Other Structures.....	43

## TABLE OF CONTENTS

6.3.2	ROADWAY.....	43
6.3.2.1	New Roadway Alignment or Widening .....	44
6.3.2.2	Evaluation of Existing Pavement Section and Subgrade .....	46
6.3.2.3	Bedrock.....	47
6.3.2.4	Peat Deposits, Compressible Soils, and Very Soft Soils.....	47
6.3.3	GEOHAZARDS .....	48
6.3.3.1	Artesian Conditions .....	48
6.3.3.2	Landslides – Slope Failure .....	49
6.3.3.3	Karst/Sinkholes (Define, Characteristics).....	49
6.3.3.4	Underground Mines .....	49
6.3.3.5	Hazardous Materials .....	50
6.3.4	OTHER CASES.....	50
6.3.4.1	Sewers .....	50
6.3.4.2	Infiltration, Detention or Underground Storage Basins.....	50
6.3.4.3	Wetland Mitigation .....	51
6.3.4.4	Trenchless Pipe Installation.....	51

## **SECTION 7 – LABORATORY TESTING.....53**

<b>7.1</b>	<b>GENERAL.....</b>	<b>53</b>
<b>7.2</b>	<b>SOIL .....</b>	<b>53</b>
7.2.1	GRAIN SIZE ANALYSIS .....	53
7.2.1.1	Sieve Analysis .....	53
7.2.1.2	Hydrometer .....	54
7.2.2	MOISTURE CONTENT.....	54
7.2.3	ATTERBERG LIMITS.....	54
7.2.3.1	Liquid Limit .....	54
7.2.3.2	Plastic Limit .....	54
7.2.3.3	Shrinkage Limit.....	55
7.2.4	SPECIFIC GRAVITY .....	55
7.2.5	UNIT WEIGHT .....	55
7.2.6	STRENGTH TESTS .....	55
7.2.6.1	Unconfined Compression Test .....	55
7.2.6.2	Triaxial Compression Tests.....	56
7.2.6.3	Housel Transverse Shear test.....	56
7.2.6.4	Direct Shear .....	57
7.2.6.5	Miniature Vane Shear (Torvane).....	57
7.2.6.6	Pocket Penetrometer .....	57
7.2.7	ONE-DIMENSIONAL CONSOLIDATION TEST .....	57
7.2.8	LOSS ON IGNITION TEST (LOI) – ORGANIC CONTENT.....	58
7.2.9	PERMEABILITY TESTS.....	59

TABLE OF CONTENTS

	7.2.9.1	Constant Head.....	59
	7.2.9.2	Falling Head.....	59
	7.2.9.3	Flexible Wall Permeability.....	59
7.2.10		ENVIRONMENTAL CORROSION TESTS OR ELECTRO-CHEMICAL TESTS.....	59
	7.2.10.1	pH.....	59
	7.2.10.2	Chloride.....	60
	7.2.10.3	Sulfates.....	60
	7.2.10.4	Electrical Resistivity.....	60
7.2.11		COMPACTION TEST.....	60
	7.2.11.1	Standard Proctor.....	60
	7.2.11.2	Modified Proctor.....	61
	7.2.11.3	Michigan Cone Test.....	61
7.2.12		CALIFORNIA BEARING RATIO.....	61
7.2.13		RESILIENT MODULUS TEST.....	61
<b>7.3</b>		<b>ROCK.....</b>	<b>61</b>
	7.3.1	UNIT WEIGHT.....	61
	7.3.2	STRENGTH TESTING.....	62
	7.3.2.1	Unconfined (Uniaxial) Compression Tests.....	62
	7.3.2.2	Point Load Tests.....	62
	7.3.3	ELASTIC MODULI.....	62

**SECTION 8 – MATERIALS DESCRIPTION, CLASSIFICATION, AND LOGGING..... 63**

<b>8.1</b>		<b>GENERAL.....</b>	<b>63</b>
<b>8.2</b>		<b>SOIL DESCRIPTION AND CLASSIFICATION.....</b>	<b>63</b>
	8.2.1	RELATIVE DENSITY OR CONSISTENCY.....	63
	8.2.2	COLOR.....	65
	8.2.3	MOISTURE CONDITION.....	65
	8.2.4	PARTICLE ANGULARITY AND SHAPE.....	65
	8.2.5	CONSTITUENTS AND GRADATION.....	65
	8.2.5.1	Primary.....	65
	8.2.5.2	Secondary Soil Constituents.....	68
	8.2.5.3	Tertiary.....	68
	8.2.6	ADDITIONAL DESCRIPTIVE TERMS.....	68
	8.2.6.1	Unusual Odors.....	69
	8.2.7	FIELD LOGGING.....	69
	8.2.8	GLOSSARY OF SOIL DESCRIPTION TERMS.....	69
<b>8.3</b>		<b>ROCK DESCRIPTION AND CLASSIFICATION.....</b>	<b>71</b>
	8.3.1	COLOR.....	71
	8.3.2	WEATHERING.....	71
	8.3.3	CONSTITUENTS.....	72

## TABLE OF CONTENTS

8.3.4	STRENGTH.....	72
8.3.5	GRAIN SIZE.....	73
8.3.6	DISCONTINUITIES .....	73
8.3.7	ROCK FRACTURE DESCRIPTION .....	74
8.3.8	RECOVERY AND ROCK QUALITY DESIGNATION (RQD) .....	74
8.3.9	ROCK MASS RATING (RMR) .....	74
<b>8.4</b>	<b>CLASSIFICATION OF SWAMP DEPOSITS .....</b>	<b>74</b>
8.4.1	SEDIMENTARY PEAT .....	75
8.4.2	SEMI-ORGANIC SEDIMENTARY DEPOSITS .....	76
8.4.3	FIBROUS PEAT.....	76
8.4.4	WOODY PEAT.....	77
8.4.5	MOSS PEAT .....	77
8.4.6	MUCK .....	77
8.4.7	RELATIONSHIP BETWEEN COLOR AND DEGREE OF DECOMPOSITION.....	78
8.4.8	MARL AND VERY SOFT CLAY .....	78
<b>SECTION 9 – GEOTECHNICAL ANALYSIS .....</b>		<b>81</b>
<b>9.1</b>	<b>GENERAL.....</b>	<b>81</b>
9.1.1	GEOTECHNICAL ENGINEERING QUALITY ASSURANCE .....	81
<b>9.2</b>	<b>FINAL SELECTION OF DESIGN VALUES .....</b>	<b>82</b>
9.2.1	DEVELOPMENT OF A SUBSURFACE PROFILE .....	82
9.2.2	SOIL STRENGTH DETERMINATION.....	83
9.2.3	DRAINED STRENGTH OF GRANULAR SOILS .....	83
9.2.3.1	Standard Penetration Test Corrections.....	84
9.2.3.2	Friction Angle Correlation .....	85
9.2.4	SHEAR STRENGTH OF COHESIVE SOILS.....	86
9.2.5	SELECTION OF DESIGN PROPERTIES FOR ENGINEERED MATERIALS .....	86
9.2.5.1	Embankment, Compacted in Place .....	86
9.2.5.2	Structure Embankment .....	87
9.2.5.3	Structure Backfill .....	88
9.2.5.4	Select Backfill.....	88
<b>9.3</b>	<b>ROADWAY .....</b>	<b>89</b>
9.3.1	SOIL MAP, PROFILE DRAWINGS, AND CROSS-SECTIONS.....	89
9.3.2	ROADWAY PLAN AND PROFILE.....	89
9.3.3	ROADWAY SUBGRADE.....	91
9.3.3.1	Subgrade Design Value Determination and Recommendations.....	91
9.3.3.2	Problematic Subgrade Conditions.....	91
9.3.3.3	Potholes.....	97
9.3.3.4	Impact of Water Seepage and Drainage on Subgrade .....	99

## TABLE OF CONTENTS

9.3.4	SLOPE SLOUGHING .....	101
9.3.5	CULVERTS .....	103
9.3.6	UTILITY EXCAVATIONS .....	103
9.3.7	ROADWAY SLOPES AND EMBANKMENTS .....	104
9.3.7.1	Roadway Design Responsibilities .....	105
9.3.7.2	Embankment Settlement .....	106
9.3.7.3	Slope Stability of Embankments and Slopes .....	112
9.3.7.4	Lateral Squeeze .....	116
9.3.7.5	Other Slope Stability Considerations .....	118
9.3.7.6	Stability Improvement Techniques .....	119
9.3.8	EROSION CONTROL CONSIDERATIONS.....	125
9.3.9	DETERMINATION OF PLAN QUANTITIES AND CONTRACT DOCUMENTS .....	125
<b>9.4</b>	<b>BRIDGE FOUNDATION DESIGN – LOAD AND RESISTANCE FACTOR DESIGN (LRFD) METHODOLOGY .....</b>	<b>125</b>
9.4.1	DESIGN METHODOLOGY OVERVIEW.....	126
9.4.2	FOUNDATION LOAD AND RESISTANCE DETERMINATION.....	128
9.4.3	FOUNDATION TYPE.....	128
9.4.3.1	Shallow Foundations .....	128
9.4.3.2	Driven Piles.....	132
9.4.3.3	Micropiles.....	137
9.4.3.4	Drilled Shafts .....	138
9.4.4	FOUNDATION DESIGN GUIDELINES.....	140
9.4.4.1	Deep Foundation Deflection Criteria .....	140
9.4.4.2	Lateral Loads .....	140
9.4.4.3	Scour.....	141
9.4.4.4	Downdrag.....	141
9.4.4.5	Reuse of Existing Foundations .....	142
9.4.5	OVERALL STABILITY.....	142
<b>9.5</b>	<b>FOUNDATION DESIGN–ALLOWABLE STRESS DESIGN (ASD) METHODOLOGY. 143</b>	
9.5.1	SPREAD FOOTINGS – ALLOWABLE STRESS DESIGN.....	143
9.5.2	DRIVEN PILES – ALLOWABLE STRESS DESIGN.....	144
9.5.3	MICROPILES – ALLOWABLE STRESS DESIGN.....	144
9.5.4	DRILLED SHAFTS – ALLOWABLE STRESS DESIGN .....	144
<b>9.6</b>	<b>RETAINING WALL DESIGN.....</b>	<b>145</b>
9.6.1	GRAVITY RETAINING WALLS.....	149
9.6.2	MSE WALLS.....	151
9.6.3	NONGRAVITY CANTILEVERED WALLS.....	152
9.6.4	ANCHORED WALLS .....	154
9.6.5	SOIL NAIL WALLS .....	154
9.6.6	TEMPORARY GEOTEXTILE WALL.....	155

TABLE OF CONTENTS

**9.7 REINFORCED SOIL SLOPES..... 156**  
9.7.1 REINFORCED FILL MATERIALS ..... 156

**9.8 OVERHEAD SIGNS, LUMINAIRES, TRAFFIC SIGNALS, NOISE BARRIER WALLS,  
CCTV POLES, AND BUILDINGS ..... 156**

**SECTION 10 – GEOTECHNICAL REPORTING ..... 159**

**10.1 GENERAL..... 159**

**10.2 GEOTECHNICAL DATA REPORT..... 160**  
10.2.1 SOIL BORING NAMING CONVENTION ..... 160

**10.3 CONTENTS OF GEOTECHNICAL ENGINEERING REPORT ..... 161**  
10.3.1 PRELIMINARY GEOTECHNICAL OR LETTER REPORT ..... 161  
10.3.2 FINAL GEOTECHNICAL REPORT..... 163  
10.3.2.1 Executive Summary (Optional)..... 163  
10.3.2.2 Table of Contents ..... 163  
10.3.2.3 Introduction ..... 163  
10.3.2.4 Project Description..... 164  
10.3.2.5 Field Investigation ..... 164  
10.3.2.6 Laboratory Testing ..... 164  
10.3.2.7 Site Conditions ..... 164  
10.3.2.8 Subsurface Conditions..... 164  
10.3.2.9 Design Analysis and Recommendations..... 165  
10.3.2.10 Construction Considerations..... 174  
10.3.2.11 Attached Figures ..... 176  
10.3.2.12 Appendix A ..... 176  
10.3.2.13 Appendix B ..... 177  
10.3.2.14 Other Appendices..... 179  
10.3.3 REPORTS FOR BUILDINGS..... 179  
10.3.4 CALCULATIONS ..... 179

**10.4 ADDENDUM REPORTS ..... 180**

**10.5 SPECIAL PROVISION..... 180**

**SECTION 11 – REFERENCES ..... 181**

**11.1 REFERENCES..... 181**

**LIST OF TABLES**

Table 1: Terms Used to Convey Geotechnical Policy ..... 3

Table 2: Geotechnical Software ..... 4

Table 3: Minimum Number of Building Borings..... 42

Table 4: Relative Density for Cohesionless Soils ..... 64

Table 5: Consistency for Cohesive Soils ..... 64

Table 6: Moisture Content Descriptions ..... 65

Table 7: Rock Type Classifications..... 71

Table 8: Rock Weathering Terms ..... 72

Table 9: Strength Terms ..... 73

Table 10: Terms to Describe Rock Grain Size..... 73

Table 11: Terms to Describe Degree of Rock Fractures..... 74

Table 12: Estimated Shear Strengths and Unit Weights for Preliminary Embankment Analysis ..... 87

Table 13: Frost Susceptibility Classification of Soils (NCHRP 1-37A, 2004) ..... 95

Table 14: Shear Strengths and Drainage Conditions for Slope Stability Analysis (after FHWA-NHI-05-123, 2005) ..... 113

Table 15: Limit States (modified after FHWA-NHI-05-094) ..... 127

Table 16: Fill Wall Evaluation Factors (modified after Earth Retaining Structures, 2008, FHWA-NHI-07-071) ..... 147

Table 17: Cut Wall Evaluation Factors (modified after Earth Retaining Structures, 2008, FHWA-NHI-07-071) ..... 148

Table 18: Soil Boring Naming Convention ..... 161

**LIST OF FIGURES**

Figure 1: Metal Core Box with Styrofoam Inserts..... 19

Figure 2: Wood Core Box with Wood Inserts..... 19

Figure 3: Recommended Practice for Plugging Soil Borings ..... 32

Figure 4: Soil Boring Layout for Retaining Walls ..... 39

Figure 5: Typical Spiral Augers ..... 64

Figure 6: The Formation of Sedimentary Peat..... 76

Figure 7: The Formation of Fibrous Peat ..... 77

Figure 8: The Formation of Woody Peat ..... 77

Figure 9: Example 1 Soil Boring Data Sheet ..... 79

Figure 10: Example 2 Soil Boring Data Sheet ..... 80

Figure 11: Angle of Internal Friction vs. N-value (After Peck et al, 1974)..... 86

Figure 12: Cut to Fill Transition Undercut..... 93

Figure 13: Load Transfer from Axle Loads on Concrete Joints (After MATES, Issue No. 14) ..... 98

Figure 14: Pumping Water at Joint (after MATES, Issue No. 14) ..... 99

Figure 15: Soil Slough in Spring..... 102

Figure 16: Existing Roadway Slopes..... 104

Figure 17: Schematics of Lateral Squeeze Phenomenon ..... 116

Figure 18: Definitions of Parameters in Calculating Factor of Safety Against Lateral Squeeze..... 117

Figure 19: Examples of Abutment Tilting Due to Lateral Squeeze (FHWA, 2006a) ..... 118

Figure 20: Rock Buttress Integrated into Slope Fix (TRB SR 247, 1996) ..... 123

Figure 21: Rock Buttress at Toe of Slope (FHWA, 2005)..... 123

Figure 22: Cobblestone Ditch at Slope Interface ..... 124

Figure 23: Flowchart for LRFD Spread Footing Design..... 131

Figure 24: General Flowchart for LRFD Pile/Shaft Design..... 133

Figure 25: Abutment Stability Analysis Critical Section ..... 143

Figure 26: Gravity Mass Concrete Wall and Gabion Basket Wall (AASHTO LRFD, November 2017) ..... 149

Figure 27: Gravity – Precast Segmental and Modular Block Walls (AASHTO LRFD, November 2017) ..... 150

Figure 28: Semi-Gravity Retaining Walls -a) Cantilever, b) Counterfort, c) Buttress (Earth Retaining Structures, June 2006) ..... 150

Figure 29: Generic Cross-Section of an MSE Structure..... 151

Figure 30: Nongravity Retaining Walls-a) Cantilever, b) Anchored, c) Braced, d) Deadman Anchored (Earth Retaining Structures, June 2008) ..... 153

Figure 31: General Cross-Section of a Soil Nail Wall (after Soil Nail Walls Reference Manual, 2015, FHWA-NHI-14-007) ..... 155

Figure 32: General Cross-Section of a CCTV Foundation ..... 157

Figure 33: Geotechnical Report Table of Sign Foundation Recommendations..... 163

Figure 34: Stability Analysis Summary Graphic..... 167

Figure 35: Spread Footing Design Summary Table ..... 168

Figure 36: Spread Footing Bearing Resistance Summary Chart..... 169

## TABLE OF CONTENTS

Figure 37: Example of Driven Pile Analysis Summary Table .....	170
Figure 38: Example of Micropile Analysis Summary Table .....	171
Figure 39: Example of Micropile Lateral Analysis Summary Table .....	171
Figure 40: Example of Drilled Shaft Foundation Analysis/Recommendations Summary Table .....	172
Figure 41: Example of Drilled Shaft Lateral Analysis Summary Table.....	173
Figure 42: Example of Permanent Tieback Sheet Pile Wall Design Summary Table .....	174
Figure 43: Example of Permanent Cantilever Sheet Pile Wall Design Summary Table .....	174

If you require assistance accessing this information or require it in an alternative format, contact the Michigan Department of Transportation's (MDOT) Americans with Disabilities Act (ADA) coordinator at [Michigan.gov/MDOT-ADA](https://Michigan.gov/MDOT-ADA).

# PAGE INTENTIONALLY LEFT BLANK

## SECTION 1 – INTRODUCTION

### 1.1 INTRODUCTION

The purpose of the Michigan Department of Transportation (MDOT) *Geotechnical Manual* (the Manual) is to convey MDOT geotechnical policies and procedures for design and construction of transportation infrastructure and appurtenances. The creation of the Manual complements the overall objective of the Geotechnical Services Section (GSS) of providing for safe, economical, effective and efficient geotechnical designs.

Entities that perform work for MDOT or on MDOT funded projects are expected to adhere to the criteria presented in the Manual. When deviations from guidelines presented in the Manual are needed, the GSS must be consulted to determine the appropriate course of action. The Manual supersedes the Fifth Edition of the *Field Manual of Soils Engineering* and the 2004 Edition of the *Geotechnical Investigation and Analysis Requirements for Structures*.

The format of the Manual is intended to present information in the same general sequence as it would occur during project development for a conventional design-bid-build project. With that said, the Michigan Department of Transportation (MDOT) is continually looking at ways to improve project delivery to the public and does utilize innovative contracting mechanisms to achieve this goal. As such, the Manual contents also will apply on recently used contractual procedures for Design Build and Construction Management-General Contractor processes.

The Manual presents most of the information normally required in the geotechnical design of transportation projects; however, it is impossible to address every situation that designers will encounter. Therefore, designers must exercise good engineering judgment on individual projects. Any questions concerning the applicability of procedure, analysis, or method should be directed to the GSS for review and comment. MDOT manuals are reviewed either monthly or annually and revised as necessary. At times during the geotechnical investigation and analysis, it may be helpful to obtain information from MDOT manuals. The following link provides access to these [manuals](#).

## SECTION 2 – GENERAL INFORMATION

### 2.1 ADMINISTRATIVE OR ORGANIZATIONAL STRUCTURE

This subsection summarizes the responsibilities of MDOT’s geotechnical engineering staff. In general, the geotechnical staff is broken into two sections: the Geotechnical Service Section (GSS) located in Lansing and the region soils engineer located in each region. Under the umbrella of the Bureau of Bridges and Structures, the overall GSS personnel structure services geotechnical needs for both design and construction aspects on MDOT projects.

It should be noted that the Manual only addresses geotechnical aspects of pavement design. How this information is applied in pavement and roadway design can be found in the [MDOT User Guide for Mechanistic-Empirical Pavement Design](#) manual.

### 2.2 PROJECT DEVELOPMENT PROCESS

MDOT’s project development process consists of a complex system with several predefined tasks. Within the MDOT system, Planisware is the software used to manage a project via these tasks. Typical tasks allocated for geotechnical services include the following:

- Task 3510 – Roadway Geotechnical Investigation
- Task 3325 – Geotechnical Site Characterization – Structures
- Task 3530 – Geotechnical Foundation Engineering Report
- Task 3815 – Geotechnical Design Review – Structures

In general, Task 3510 functions are associated with field investigations and recommendations associated with roadway related infrastructure. Tasks 3325, 3530, and 3815 are directly associated with the bridge investigation and design process. A complete description of these Project Development Tasks is provided on the MDOT website or in the Project Management Development/Design Task Manual. In addition, the [Project Task flowchart](#) is provided on MDOT’s website and provides a graphical view of how each task fits into the overall project development process.

### 2.3 GEOTECHNICAL DESIGN POLICIES AND THEIR BASIS

Technical policies and design requirements provided in the Manual have been derived from national standards and design guidelines such as those produced by American Association of State Highway and Transportation Officials (AASHTO) and the Federal Highway Administration (FHWA). The following manuals, listed in order of priority, are the primary source of geotechnical policy for MDOT:

1. AASHTO LRFD Bridge Design Specifications, most current edition plus interims
2. FHWA Manual on Subsurface Investigations, most current edition

FHWA geotechnical manuals, or other nationally recognized design manuals, are considered secondary relative to the AASHTO manuals listed above for establishing MDOT geotechnical

design policy. FHWA geotechnical manuals have been used to address areas not specifically covered by the above listed AASHTO manuals. Where justified by research or local experience, the design policies and requirements provided herein may deviate from the AASHTO and FHWA design specifications and guidelines and shall supersede the requirements and guidelines within the AASHTO and FHWA manuals.

For foundation and wall design, the load and resistance factor design (LRFD) approach must be used to be consistent with MDOT Bridge Design policy. For aspects of foundation and wall design that have not yet been developed in the LRFD format, allowable stress (ASD) or load factor design (LFD) will be used until such time the LRFD approach has been developed.

In the Manual, terms and definitions provided in the table below are used to convey geotechnical policy.

Table 1: Terms Used to Convey Geotechnical Policy

Term	Definition
Must	The associated provisions must be used. There is no acceptable alternative.
Should	The associated provisions must be used unless strong justification is available and provided based on well-established regional or national practice, and if backed up by well accepted research results.
May	The associated provisions are recommended, but alternative methods or approaches that are consistent with the intent of the provisions are acceptable.
Evaluate, evaluated, address, addressed	The associated issue must be evaluated or addressed through detailed analysis and the results documented.
Consider, considered	The associated recommended provisions must be evaluated, and the reasons and analyses used to decide whether to or not to implement the recommended provisions must be documented.
Geotechnical Engineer	The geotechnical engineer, soils engineer, or engineering geologist who has been given responsibility to coordinate the geotechnical design, field investigation, or research activities for the project.

### 2.3.1 MANUAL CHANGES

It is intended that the Manual will be continually updated as required to clarify geotechnical practice in MDOT and include new information. Revisions and submittals from all users of the Manual, both inside MDOT and consultants, are encouraged. The following revision procedure should be used:

1. *Define the Problem* - Discuss the suggestion or revision of the Manual with others that have a stake in the outcome. If it is agreed the item should be proposed, develop a written proposal.
2. *Develop a Written Proposal* - Research and develop a written proposal using the three general subject headings:
  - Problem Statement – Clearly state the existing problem.
  - Analysis/Research Data – Research and analysis of the problem and potential solution are thorough and understandable.
  - Proposal – Present solution that is supported by facts and solves the problem. Include impact on other areas and how these impacts have been coordinated with other areas.
3. *Review and Approval* - After reviewing the written proposal for completeness, the Geotechnical Services Section will either accept, without further review, manual corrections for inclusion in the Manual or advance the proposal to other sections within MDOT for further review and comment.

Regardless of whether a proposal is accepted, the Geotechnical Services Section will reply in writing to the person making the submittal.

4. *Implementation of Approved Revision* - After a proposal has final approval, a revised manual page will be prepared for inclusion into the document. The Geotechnical Services Section will keep records of manual changes. Major changes like adding new sections will require the words “REVISED Month Year” to be placed adjacent to the initial date on the Manual’s cover and in page footers.

## 2.4 GEOTECHNICAL SOFTWARE

This section provides a general overview of software used in geotechnical engineering and analysis. The following table provides a list of software, including but not limited to, which is currently used by MDOT or its representatives. Consultants are not required to obtain the same software as MDOT unless indicated by an asterisk, but all software must adhere to the models and theory permitted in the Manual.

Table 2: Geotechnical Software

Analysis Type	Software
Soil Boring Log Preparation	<ul style="list-style-type: none"> <li>• Gint*</li> <li>• BoreDM*</li> <li>• OpenRoads (or future version)*</li> </ul>
Structure Foundation Analysis	<ul style="list-style-type: none"> <li>• Driven</li> <li>• DrivenPiles</li> <li>• Apile</li> </ul>

Analysis Type	Software
	<ul style="list-style-type: none"> <li>• GRLWEAP</li> <li>• CAPWAP</li> <li>• LPILE</li> <li>• COM624</li> <li>• FoSSA</li> <li>• EMBANK</li> <li>• GROUP</li> <li>• FB-MultiPier</li> </ul>
Retaining Wall Analysis, Steepened Slopes, and Shoring Analysis	<ul style="list-style-type: none"> <li>• MSEW</li> <li>• ReSSA</li> <li>• SupportIT</li> <li>• SPW 911</li> <li>• CivilTech Software Shoring Suite</li> </ul>
Slope Stability	<ul style="list-style-type: none"> <li>• Slide</li> <li>• SLOPE/W</li> <li>• PCSTABL</li> <li>• RSS</li> </ul>
Miscellaneous Analysis	<ul style="list-style-type: none"> <li>• Microsoft Excel</li> <li>• MathCADD</li> </ul>

## SECTION 3 – CONSULTANT CONTRACTS

### 3.1 GENERAL

MDOT has historically utilized geotechnical consultants to provide geotechnical engineering services on selected projects. Performing work in this capacity requires consultants to be prequalified in the Design-Geotechnical and/or Design-Geotechnical: Advanced classifications. Requirements to obtain prequalification status can be viewed by clicking on this [link](#). Please note that obtaining prequalification status does not guarantee work from MDOT.

### 3.2 CONSULTANT CONTRACTING METHODS

The following three avenues are typical ways geotechnical consultants can perform work for MDOT.

#### 3.2.1 DESIGN-BID-BUILD PROJECTS

- The Geotechnical Services Section (GSS) issues a Request for Proposal for Statewide As-Needed Geotechnical Services. Selected consultants are then contracted as needed when projects arise. While the scoping of work may vary in complexity with this contract, the statewide contract typically encompasses more complex geotechnical work such as bridge foundation design, geo-hazard investigation and analyses, or embankment settlement and stability analyses in challenging soil conditions. This type of work requires prequalification in the Design-Geotechnical: Advanced classification. The selected consultants act as an extension of the GSS. Statewide as-needed opportunities are advertised on MDOT's website under Vendor/Consultant Services.
- The MDOT region office issues a Request for Proposal for As-Needed Geotechnical Services specific to that region. Selected consultants are then contracted by the region soils engineer to provide services as required. In general, the scope of work for these contracts encompass soil borings and pavement core acquisitions, standard plan foundation analyses and recommendations (e.g., strain poles, overhead signs), and roadway recommendations. This type of work requires prequalification in the Design-Geotechnical classification. These consultants act as an extension of the region soils engineer. In addition, regional based opportunities are advertised on MDOT's website under Vendor/Consultant Services.
- Request for Proposals for transportation projects (e.g., roadway reconstruction/rehabilitation, bridge widening/reconstruction, Intelligent Transportation System structures) are advertised on MDOT's website. As part of this request for proposal, a secondary prequalification of either geotechnical classification is listed on the request and opportunities exist to be on a project design team in this capacity. Projects typically consist of either roadway or bridge design services.

In general, geotechnical consultants working directly with the GSS or region offices will do so through a formal contract in which the consultant is assigned project specific tasks. Through these tasks, the consultant is typically responsible to develop a detailed geotechnical investigation plan, conduct a field investigation, perform testing and design, and produce a geotechnical report. On certain projects requiring only drilling/coring services, the number of soil borings/pavement cores and depths should be defined by the GSS or region soils engineer. For these as-needed assignments, the consultant is viewed as an extension of MDOT's geotechnical staff; therefore, frequent communication between MDOT's geotechnical staff and the consultant is essential for a successful project.

When a geotechnical subconsultant is retained by a prime design consultant, the GSS or region soils engineer should assist the MDOT project manager in development of any special/specific geotechnical requirements on the project. In addition, the GSS or region soils engineer may assist as needed in review of the geotechnical consultant cost estimate and geotechnical consultant work product.

### 3.2.2 INNOVATIVE CONTRACTING METHODS

Innovative contracts consist of design-build, construction management-general contractor, alternate technical concepts, and public private partnership projects. Opportunities exist for geotechnical companies to be a subconsultant to the prime consultant or contractor in these settings as well. Future innovative contracting projects can be found on the MDOT Innovative Contracting website by clicking on this link [Innovative Contracting](#). Prequalification in one or both geotechnical classifications is required to perform services on these types of projects.

### 3.2.3 SPECIAL PROJECTS

The GSS or region may select a consultant to conduct geotechnical research, special studies, or prepare documents. Upon request by the region on these project types, the GSS and/or region soils engineer should provide assistance in the following ways.

- Determine the scope of services required.
- Prepare Request for Qualifications.
- Review overall proposal.
- Review price proposal.
- Attend initial scoping meetings with selected consultant and other meetings as needed.
- Review final deliverable.

## SECTION 4 – MICHIGAN GLACIAL HISTORY

### 4.1 FUTURE SECTION TO BE DEVELOPED

## SECTION 5 – FIELD INVESTIGATION TECHNIQUES AND PROCEDURES

### 5.1 GENERAL

This section provides guidelines and commonly used techniques for determining the scope of a geotechnical field investigation. As requirements and conditions will vary with each project, engineering judgment is essential in tailoring the investigation to the specific project. Useful references that provide extensive information on planning and conducting a geotechnical investigation are NHI 132031 *Subsurface Investigations-Geotechnical Site Characterization* and GEC-5 *Evaluation of Soil and Rock Properties* published 2002, and GEC-5 *Geotechnical Site Characterization* published 2017.

#### 5.1.1 REVIEW OF PROJECT REQUIREMENTS

One item to initially consider when planning and performing a subsurface investigation is a thorough review of the project requirements. Useful items for the Geotechnical Engineer to review are the following:

- Project location and size.
- Project type (current and proposed alignment, reconstruction, widening, improvement, structure type, and slope stability).
- Project criteria (structure locations, structure loads, bridge span lengths, maintenance of traffic, and cut and fill locations).
- Project constraints (right-of-way, environmental considerations, and permitting).
- Project design and construction timelines and budgets.

#### 5.1.2 REVIEW OF AVAILABLE DATA

Upon review of the project requirements, the Geotechnical Engineer should review all available pertinent information sources as part of the planning process. Further research into these data sources could provide valuable information in determining applicable soil boring number, type, depths, and other sources of testing as necessary. The following sections highlight potential sources that should be considered in developing a field investigation.

##### 5.1.2.1 Topographic Maps

These maps are prepared by the U.S. Geological Survey (USGS) and are readily available at the USGS Topographic Maps or [Michigan Geographic Data Library](#). Physical features, configuration and elevation of the ground surface, and surface water features are portrayed on these maps. This data is valuable in determining preliminary accessibility for field equipment and possible problem areas.

#### 5.1.2.2 Aerial Photographs

These photographs are available from commercial web mapping sources and the Michigan Geographic Data Library noted in Section [5.1.2.3](#). They are valuable in that they can provide the basis for reconnaissance and, depending on the age of the photographs, show manmade structures, excavations, or fills that affect accessibility and the planned depth of exploration. Historical photographs can also help determine the reasons and timeline of channel migration, general scour, and sinkhole activity.

#### 5.1.2.3 Geological Maps and Reports

Considerable information on the geological conditions of an area can often be obtained from geological maps and reports. These reports and maps often show the location and relative position of the different geological strata and present information on the characteristics of the different strata. This data can be used directly to evaluate the rock conditions or depths to be expected and indirectly to estimate possible soil conditions since the parent material is one of the factors controlling soil types. These maps may also be useful to the Geotechnical Engineer in delineating areas of karst or existing underground mines. Geological maps and reports can be obtained from the USGS, [Michigan Geological Survey website](#), [DTMB - Maps | Geographic Information Systems \(GIS\)](#) and local university libraries.

#### 5.1.2.4 Natural Resources Conservation Service Soil Surveys

These surveys are compiled by the U.S. Department of Agriculture usually in the form of county soils maps. These surveys can provide valuable data on shallow surface soils including mineral composition, grain size distribution, depth to rock, general water table information, drainage characteristics, geologic origin, and presence of significant organic deposits. Published and downloadable county soil maps are available on the Natural Resources Conservation Service (NRCS) [Soil Survey](#) web page while interactive soil maps are available on the [NRCS Web Soil Survey](#) web page.

#### 5.1.2.5 Water Well Surveys

The Michigan Department of Environment, Great Lakes, and Energy (EGLE), formerly the Michigan Department of Environmental Quality (MDEQ), has developed a web-based database of water wells drilled throughout Michigan. These files are useful in obtaining general soil and rock types and depths in a specific area. Groundwater depth information is typically documented in these files as well. This resource can be located on the [EGLE Wellogic](#) website.

#### 5.1.2.6 Existing Design Plans and Construction Records

MDOT has many archived plans and construction records of the existing roadways and structures. Obtaining and reviewing this information can be useful for the Geotechnical Engineer in many ways. Specific knowledge of the subsurface conditions, foundation

type, depth, width, and other existing underground structures can be determined from these plans. These plans can typically be obtained through a request to the MDOT project manager for the project. The *Field Manual of Soil Engineering* should be referenced for the design methodology utilized in the development of these plans.

Some caution is advised when reviewing the soil boring information in older versions of the plans. Older drilling and field testing methods, such as jetting or manual Standard Penetration Test (SPT) hammers, may not be as reliable as drilling and field testing methods utilized today. As a result, variations in the subsurface conditions than those indicated in these documents may be observed utilizing present-day drilling equipment and procedures.

#### 5.1.2.7 Remote Sensing

A tool that is starting to gain use for gathering large amounts of terrain or topographical data is the use of Light Detection and Ranging (LiDAR) surveys. LiDAR surveys are comprised of three types. Each type and best use practices are summarized below.

1. Mobile – The survey equipment for this type of scan is mounted on a vehicle and is capable of traveling at near highway speeds. This scan type is capable of collecting large amounts of corridor information in a quick and safer way when compared to traditional survey methods.
2. Terrestrial – Terrestrial LiDAR is mounted on a tripod and is useful in collecting very accurate survey information in a localized area. This method is very useful in collecting data in hard to access areas (cliff faces, steep slopes) or when repeatable data is desired to compare current and future land topography conditions.
3. Aerial – When topographical data or general land features are needed, aerial LiDAR provides a great tool in cheaply collecting this data from the user's desktop. This data is available for MDOT users through [MiSAIL website](#). The data is best used from hydraulic surveys, conceptual or preliminary roadway re-alignments, or geohazard delineation such as sinkholes or a preliminary slope stability investigation.

#### 5.1.3 SITE RECONNAISSANCE

As part of the planning phase, the Geotechnical Engineer should visit the project site. The site visit is most effective when conducted after the previously noted project site information has been collected and reviewed. The visit will enable the engineer to observe first-hand the field conditions and more accurately correlate previous data with newly obtained site information. The following items, if applicable, should be defined by the site reconnaissance:

- Drilling Logistics – define approximate boring locations, required routes to access borings, type of equipment required, location of existing benchmark (if applicable), evidence of buried or overhead utilities, right-of way or private property access, traffic

control required to perform soil borings, equipment storage areas, water supply, site restoration, cutting disposal, etc.

- Structures – consider nearby structures/utilities and how they will impact the field investigation and design development. Note condition of existing pavements and structures.
- Permits – determine the various types of permits that may be required.
- Land & Water Features – escarpments, outcrops, erosion features, surface settlement, marshes, vegetation, slope failures or sloughing, drainage, scour, flood levels, channel migration, adjacent land usage, etc.

## 5.2 PERMITS

A right-of-way permit is required to perform work within MDOT's right-of-way. More information on the process for obtaining this permit is provided in [Task 3510](#) and [3325](#) descriptions. In addition, permits can be obtained through the [MDOT Permit Gateway](#).

When drilling in or near lakes and streams, a permit is required under Part 301 and for wetlands Part 303 of 1994 PA 451, as amended, from EGLE. If work is being conducted for the department, the permit is coordinated through the Transportation Service Center. If the work is for a private entity, the applicant must go through EGLE directly.

## 5.3 FIELD WORK ON PRIVATE PROPERTY

If the field investigation extends outside the MDOT right-of-way, the Geotechnical Engineer must obtain written permission prior to entering the property. Right-of-way maps are available for all MDOT trunklines and can be obtained via coordination with the MDOT project manager. The Geotechnical Engineer should consult these maps if field activities extend outside MDOT's right-of-way. Obtaining right of entry is typically conducted by MDOT and can be coordinated by the MDOT project manager.

### 5.3.1 RAILROAD ACCESS

If the field investigation is near or within the railroad right-of-way, it is necessary to coordinate the field work with the railroad company. The coordination is initially conducted through the MDOT project manager.

The schedule for obtaining permission/permits from the railroad company can sometimes be a long process. Consequently, this coordination should begin as soon as possible once it is realized that work is required within the railroad right-of-way. Depending on the location of the field investigation, the railroad may require a safety course before work can proceed. Dependent on the distance the drilling is from the track, the railroad may also require a flagger during the field investigation.

For consultant contracts, the Geotechnical Engineer should account for costs associated with work conducted in the railroad right-of-way in their price proposal.

### 5.3.2 DOCUMENTATION OF PROPERTY DAMAGE

The Geotechnical Engineer is responsible for documenting any damage that occurs during the field investigation. Examples of this are crop damage, tire ruts in the lawn, cutting trees or shrubs, and utilities. The field personnel must document the type and extent of the damaged item. For trees, the size and type of tree must be recorded. Take photographs of the damaged area/item and at completion of any repaired area.

For consultant contracts, the Geotechnical Engineer should account for costs within the price proposal that are associated with damages that occur during the field investigation, if applicable. In the case where unexpected damages occur, the Geotechnical Engineer should contact the MDOT project manager for further direction.

## 5.4 UTILITY LOCATION/NOTIFICATION

Prior to drilling, it is necessary for the Geotechnical Engineer to determine the location of any utilities within the area. For most areas, underground utilities can be determined by contacting the Statewide “[MISS DIG](#)” system. Review of existing plans can also provide additional insight into where existing or abandoned utilities may be located.

MDOT roadway right-of-ways include freeway lighting and storm sewers, Intelligent Transportation Structures, and miscellaneous electrical systems, which are not typically part of the MISS DIG System. The Geotechnical Engineer is responsible for contacting the appropriate MDOT agency noted in [Task 3510 or 3325](#) descriptions to provide appropriate clearance for these utilities. For utilities not located through the MISS DIG system, a “soft dig” utilizing hand digging or vacuum type equipment may be necessary prior to conducting the field investigation.

## 5.5 DRILLING SAFETY

The nature of the equipment used and climatic conditions often present potential hazards that should be evaluated on a site-specific basis. It is the responsibility of the Geotechnical Engineer, as well as field crew members, to adjust the investigation program and/or provide equipment, training, and other means to provide safe working conditions. It may be necessary to prepare a unique safety plan for unusual projects to provide guidance for field staff, which could include unique safety practices, emergency contact information, and considerations for first aid.

Minimum protective gear for all field personnel should be in compliance with MDOT’s Personal Protection Equipment Policy, as stated in [MDOT PPE Guidance doc 10118.pdf](#). During drilling, field personnel should also use tear-away safety vests.

Nonroutine environmental issues may be encountered during a site investigation. For example, discolored odorous soil or contaminated groundwater may be detected from previous site

studies during the planning process or during drilling and sampling operations. Other geologic conditions that can create issues during drilling operations and require preplanning are artesian groundwater or naturally occurring methane gas. When geotechnical investigations must be conducted under such conditions, significant preplanning is required not only to protect the field crew, but also to comply with any governing environmental regulations. These conditions may require additional personal protection equipment and training during the field investigation and disposal of contaminated spoils at an appropriate location.

## 5.6 DRILLING AND SAMPLING OF SOIL AND ROCK

Various types of drilling and sampling techniques are typically utilized on MDOT projects. Drilling equipment utilized to advance the borehole must be noted on the field log. This section summarizes general information on the equipment, methods, and techniques utilized during a typical field investigation.

### 5.6.1 EQUIPMENT

Several factors influence the applicability and selection of subsurface exploration equipment and methodology for site investigation. Selection of equipment and methods are usually based on geotechnical data needs and geologic conditions but may also be based on site access, equipment availability, project budget, environmental restrictions, or a combination of these.

Geotechnical Engineers should be familiar with the exploration methods applied on their projects, their results, and potential limitations or effects on the data they receive from the field. For a specific project, the Geotechnical Engineer should carefully consider the drilling and sampling methods best suited. The main purpose of the subsurface investigation is adequate site characterization. The quality of the results is an important facet of the subsurface investigation, and different drilling techniques are better suited to certain materials and conditions. Michigan is a state of very diverse soil and rock conditions and proper selection of tooling is critical to achieve high quality and timely results. Achieving quality results from a drilling program are more important than convenience.

### 5.6.2 DRILLING METHODS

#### 5.6.2.1 Continuous Flight or Hand Auger Borings

This drilling method consists of rotating an auger while simultaneously advancing it into the ground to the desired depth. Samples of cuttings can be removed from the auger; however, the depth of the sample can only be approximated. These samples are disturbed and should be used only for material identification. Primary uses include soil strata and groundwater determination and hole advancement prior to SPTs. Machine auger borings have been widely used within MDOT to evaluate shallow subsurface conditions for roadway investigations. Auger borings are limited in depth by the presence of groundwater or collapsible soils. The standard practice for advancing augers is described by ASTM D1452.

Manual hand auger borings are another method utilized in field investigations. Hand auger borings are limited in depth by the presence of groundwater and collapsible soil. Additionally, penetration into hard or dense soil can be difficult due to the operator's physical limitations. These borings are typically utilized to supplement other drilling methods or in areas that normal drilling equipment are unable to access.

#### 5.6.2.2 Hollow-Stem Auger Borings

A hollow-stem auger (HSA) consists of a continuous flight auger surrounding a hollow drill stem. This advancement method is one of the most common drilling methods utilized in Michigan. The HSA is advanced similar to other augers; except, removal of the hollow stem auger is not necessary for sampling. SPT and undisturbed samples are obtained through the hollow drill stem, which acts like a casing to hold the hole open. As a supplemental form of verification, soil cuttings observed by the driller/field engineer can be utilized to determine soil strata type. Monitoring wells and piezometers can also be installed using this method.

When groundwater is encountered, appropriate action to mitigate differential hydrostatic head that develops between the inside and outside of the auger casing must be taken to prevent unreliable SPT results. The standard practice for using hollow-stem augers is described by ASTM D6151.

#### 5.6.2.3 Rotary Drilling

Rotary drilling is one of the common methods utilized in Michigan. In this method, the boring is advanced by a combination of the chopping action of a light bit and jetting action of the water flowing through the bit. A downward pressure applied during rotation advances the hollow drill rods with a cutting bit attached to the bottom. The drill bit cuts the material and the drilling fluid washes the cuttings from the borehole. SPT and undisturbed samples are obtained through the drilling fluid, which holds the borehole open. To obtain accurate water level readings during the field investigation, this drilling method should be used in addition to hollow-stem augers or monitoring wells.

#### 5.6.2.4 Direct Push Borings (i.e., GeoProbe<sup>®</sup>)

Direct push equipment is hydraulically-powered percussion/probing machines that use the vehicle weight (sometimes with ground anchors) combined with percussion at times to advance the drill string. These machines can obtain continuous, small diameter samples through the soil strata but due to the percussion effects produce a considerable amount of sample disturbance. These samples are suitable for determining the soil profile and for performing basic index testing.

#### 5.6.2.5 Coring

The most common method for obtaining rock samples is through coring. Circulating water removes ground-up material from the hole while also cooling the bit. The rate of advance is controlled to obtain the maximum possible core recovery with a minimal amount of disturbance. Coring is to be performed in accordance with ASTM D2113 – *Standard Practice for Rock Core Drilling and Sampling of Rock for Site Investigation*. For further guidance on this topic, refer to Section [5.6.6.5 Rock Core Sampling](#).

A geologist or geotechnical engineer is often on-site during coring operations to observe the coring process and perform measurements that are pertinent in determining the rock mass characteristics.

#### 5.6.2.6 Other Drilling Methods

Other drilling advancement methods exist such as percussion (sonic), wash borings, jet, air rotary, and cable tool but are not commonly utilized for geotechnical investigations in Michigan. The Geotechnical Services Section must be contacted prior to use of these drilling methods.

### 5.6.3 BACKFILL OF BOREHOLES

Upon completion, all borings must be backfilled in accordance with the *Recommended Practice for Plugging Soil Borings* issued by the Southeastern Branch, Michigan Section, American Society of Civil Engineers. This document is appended to the end of this section as [Figure 3](#). Following these guidelines prevents cross-contamination of aquifers and reduces the risk of borehole subsidence and resulting issues that could develop (e.g., vehicle damage, adjacent roadway deterioration, delay to traveling public due to lane closure). If special cases arise that require deviation from this document, then the Geotechnical Services Section (GSS) should be contacted prior to the use of these methods.

In certain parts of the state, soil borings are performed in Michigan Wellhead Protection areas. If these aquifers are penetrated, then the boring must be backfilled per ELGE guidelines. The Michigan Wellhead Protection Map can provide the Geotechnical Engineer more geographical guidance of these protected areas.

Boreholes that penetrate through surface layers of hot mixed asphalt or concrete pavement must be suitably patched. In addition, boreholes through bridge decks must be suitably patched.

Disposal of the soil cuttings or slurry generated from the drilling process is the responsibility of the geotechnical consultant. Disposal locations should be handled on a case-by-case basis. Consultants should not assume the soils or slurry can be disposed of on site.

#### 5.6.4 SOUNDINGS

A sounding is a method of exploration in which either static or dynamic force is used to push a rod or advance an auger into the soil profile. Samples are not usually obtained with this procedure. The depth to rock or thickness of an organic layer can easily be deduced from the resistance to penetration. Soundings are considered as a supplemental form of investigation.

#### 5.6.5 TEST PITS AND TRENCHES

These are the simplest methods of inspecting subsurface soils. Test pits consist of excavations performed by hand, backhoe, vacuum truck, or dozer. They offer the advantages of speed and ready access for sampling. They are severely hampered by limitations of depth and by the fact they generally cannot be used below the groundwater table. Test pits are typically used as a supplemental form of investigation during the design phase or to investigate soil related issues and various types of structure location/depths during construction. In certain situations, soil erosion and sedimentation control measures may be required.

Upon completion, the excavated test pit should be backfilled with the excavated material or other suitable material. If future construction of a slope, roadway, or structure, is planned for this area, the backfill should be compacted in accordance with the *MDOT Standard Specifications for Construction* requirements. In areas of agricultural use or areas used to support plant growth, the operator should be instructed to keep the topsoil separate. Ideally, the operator should backfill the excavation such that the backfilled pit is reestablished to support vegetation. Reseeding may be necessary to comply with MDOT requirements.

#### 5.6.6 SAMPLING PROCEDURES

American Society for Testing and Materials International (ASTM) has procedures that must be followed for collection of field samples. Samples must be properly obtained, preserved, and transported to a laboratory facility in accordance with these procedures to preserve the samples as best as possible. See ASTM D4220 – *Standard Practices for Preserving and Transporting Soil*. Soil and rock samples collected during the field investigation are to be retained for a period of two years from the completion of the field investigation or until the project has been constructed, whichever is less. There are several procedures that can be used for the collection of samples as described below.

##### 5.6.6.1 Bulk Bag Samples

Bulk samples are highly disturbed samples obtained from auger cuttings or test pits. The quantity of the sample depends on the type of testing to be performed but can range up to 50 pounds or more. General testing performed on these samples includes classification, moisture-density, environmental testing, California Bearing Ratio, and triaxial testing on remolded specimens.

#### 5.6.6.2 Split-Barrel Sampler

The most commonly used sampling method utilized in Michigan is the split-barrel sampler, also known as the standard split-spoon. This method is used in conjunction with the Standard Penetration Test. The sampler is a 2-inch (O.D.) split barrel that is driven into the soil with a 140-pound hammer dropped 30 inches. After it has been driven 18 inches, it is withdrawn and the sample removed. The sample should be immediately examined, logged, and placed in sample jar for storage. Sample jars should be affixed with a label indicating the boring number, sample number, depth, blow counts, and percent recovery. Soil obtained with this type of sampling is adequate for moisture content, grain-size distribution, Atterberg limit tests, and visual identification. Sampling must be in accordance with ASTM D1586 – *Standard Test Method for Penetration Test and Split-Barrel Sampling of Soils*.

#### 5.6.6.3 Thin-Walled Undisturbed Tube Sampler

The thin-walled tube sampler, also known as the Shelby tube, is a thin-walled steel tube pushed into the soil to be sampled by hydraulic pressure and then after a short waiting period, spun to shear off the base. Afterward, the sampler is pulled out, immediately sealed, and taken to the laboratory facility. This process allows the sample to be undisturbed as much as possible and is suitable for fine-grained soils that require strength and consolidation tests. See ASTM D1587 - *Standard Practice for Thin-Walled Tube Sampling of Soils for Geotechnical Purposes*.

#### 5.6.6.4 Transverse Shear Core Sampling

This method of sampling collects undisturbed cohesive samples and consists of hydraulically pushing a 1.75-inch O.D. diameter by 28.75-inch-long sampling barrel into the sampled soil. Within the sampling barrel are several liners varying in length between 1 and 3 inches. For more details on this method, refer to the *Field Manual of Soil Engineering*, Fifth Edition, page 38.

Historically, this method of sampling has been performed by MDOT on a routine basis. Although this method is not commonly utilized in the private sector, MDOT uses the method on a case-by-case basis. Samples collected are tested in unconfined compression tests and transverse shear strength tests.

#### 5.6.6.5 Rock Core Sampling

Rock core sampling is used to obtain a continuous, relatively undisturbed sample of the intact rock mass for evaluation of its geologic and engineering properties. Three basic types of core barrels are single tube, double tube, and triple tube. MDOT requires the use of double or triple tube core barrels and N-size (core diameter of 1.874 in.) or larger cores when conducting rock coring. Wireline recovery methods are preferred when coring lengths exceed 10 ft. Individual core runs must be no greater than 5 ft. When

projects involve rock slope applications, the Geotechnical Engineer should consider the use of only a triple tube core barrel system because it is better suited to obtain the level of detail critical for these types of investigation. Rock coring must be labeled, preserved, and transported in accordance with ASTM D2113 and ASTM D5079. Rock core recovery and Rock Quality Designation (RQD) should be determined in the field by a qualified professional such as the geotechnical field engineer or geologist. Core samples must be placed in either wood or metal core boxes (see Figure 1 and 2).

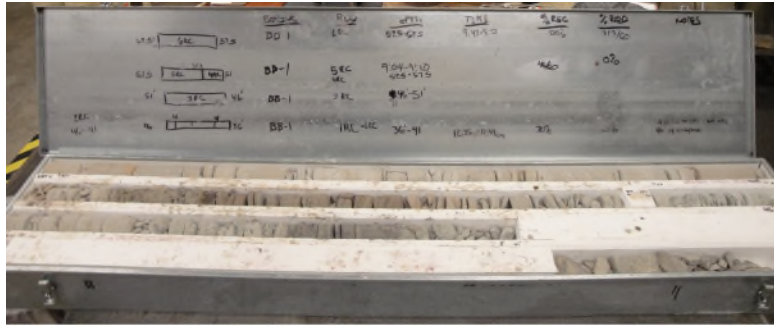

Figure 1: Metal Core Box with Styrofoam Inserts

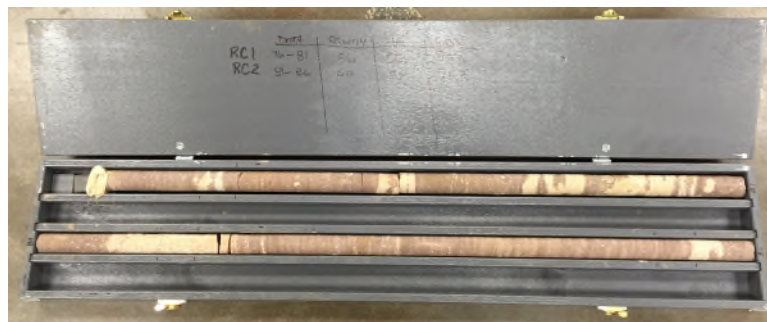

Figure 2: Wood Core Box with Wood Inserts

Once the rock core is placed in the core box and the box properly labeled, a photograph should be taken to obtain a permanent record of the original core condition at the time of recovery. Furthermore, the photographs are also useful for reviewing the condition of the core when preparing final logs and are invaluable to individuals who do not have an opportunity to inspect the actual core.

*Drilling Bits* - The proper selection of a drilling bit is critical. An improper bit is detrimental to core recovery and drilling production rates. Many resources are available to determine the appropriate bit including the references provided in Section [5.1](#) and from the bit manufacturer. Ultimately, the driller is responsible for bit selection and obtaining quality results. A combination of proper planning, being familiar with bit types, and experience coring various rock formations within Michigan aid in obtaining higher quality results.

*Core Orientation* - In some rock slope applications, it is important to understand the precise orientation of rock discontinuities for the design. Orienting recovered rock core so that it can be properly mapped and evaluated, as though it were still in place, requires special core barrels. Currently, specialized core barrels that scribe a reference mark (line) on the side of the core as it is drilled are more routinely used. Special recording devices within the core barrel relate the known azimuth orientations to the reference mark so that, when the core is subsequently removed from the core barrel, the core can be oriented to its exact in-situ position. These specialized core barrels are relatively expensive and require additional training to use properly and interpret results. Refer to NHI 132031 *Subsurface Investigations-Geotechnical Site Characterization*.

*Borehole Camera Surveys* – In special cases, boreholes can be imaged to visually inspect the condition of the sidewalls and distinguish gross changes in lithology. These devices can also be used to identify fracture zones, shear zones, and joint patterns in rock core holes. Furthermore, they aid the Geotechnical Engineer or geologist in identifying/interpreting the orientation of the rock core. The GSS should be contacted prior to using this technique.

#### 5.6.6.6 Other Sampling Methods

Other sampling methods exist such as a piston sampler, Denison core sampler, and pitcher tube sampler but are not commonly utilized for MDOT geotechnical investigations. The GSS or region soils engineer should be contacted prior to using sampling methods not listed in previous sections of the Manual.

## 5.7 GEOPHYSICAL METHODS

Geophysical techniques are nondestructive methods used to gather information over large areas and to supplement information between boreholes. These exploration techniques are most useful for extending the interpretation of subsurface conditions beyond what is determined from small diameter borings. This tool can provide information on the general subsurface profile, the depth of bedrock, depth to groundwater, the location of granular borrow areas, peat/marl deposits, or subsurface anomalies. Common methods utilized for geotechnical explorations include seismic refraction and reflection, electrical resistivity, and ground penetrating radar.

However, results can be significantly affected by many factors including the presence of groundwater, non-homogeneity of soil stratum thickness, and the range of wave velocities within a particular stratum. Subsurface strata that have similar physical properties can be difficult to distinguish with geophysical methods. Because of these limitations, geophysics should be considered a secondary exploration method to drilling and the primary exploration should be by conventional borings. Furthermore, data obtained from the surveys should be

interpreted and processed by an experienced and highly-trained geophysicist. This information must not be included in the bid documents unless otherwise approved by the GSS.

For secondary resources on this topic, see FHWA-IF-021 *Application of Geophysical Methods for Highway Related Problems* and USACE EM 1110-1-1802.

### 5.7.1 SEISMIC REFRACTION AND REFLECTION SURVEY

These methods rely on the fact that acoustic signals travel through different materials at different velocities. The times required for an induced acoustic signal to travel to set detectors after being refracted or reflected by the various subsurface materials are measured. This data is then used to interpret material types and thicknesses. Seismic refraction is limited to material stratifications in which velocities increase with depth. For the seismic refraction method, refer to ASTM D5777. Seismic investigations can be performed from the surface or from various depths within borings. For crosshole seismic techniques, see ASTM D4428.

### 5.7.2 ELECTRICAL RESISTIVITY SURVEY

This method is based on the differences in electrical conductivity between subsurface strata. An electric current is passed through the ground between electrodes and the resistivity of the subsurface materials is measured and correlated to material types. Several electrode arrangements have been developed, with the Wenner four-point electrical test being the most commonly used in the United States. Refer to ASTM G57 and D6431 for additional guidance on this topic.

Electrical resistivity testing is generally utilized for the following reasons.

- To find the depth to bedrock since soil and rock typically have different electrical resistances.
- Resistivity testing is affected by the moisture content of the soil and the presence or lack of metals, salts, and clay particles. Thus, resistivity surveys may be used to model groundwater flow through the subsurface.
- Resistivity surveys are also used to determine the potential for corrosion of foundation materials for the in-situ subsurface materials.

### 5.7.3 GROUND PENETRATING RADAR (GPR)

The velocity of electromagnetic radiation is dependent upon the material through which it is traveling. GPR uses this principle to analyze the reflections of radar signals transmitted into the ground by a low frequency antenna. Signals are continuously transmitted and received as the antenna is towed across the area of interest, thus providing a profile of the subsurface material interfaces.

GPR is limited by the contrast in the properties of adjacent material. In addition to having sufficient velocity contrast, the boundary between the two materials needs to be sharp. For instance, it is more difficult to see a water table in fine-grained materials than in coarse-grained materials because of the different relative thicknesses of the capillary fringe for the same contrast. See ASTM D6432.

#### 5.7.4 SURFACE WAVE METHODS (SASW AND MASW)

Surface wave methods consist of Spectral Analysis of Surface Waves (SASW) or Multi-channel Analysis of Surface Waves (MASW). The SASW and MASW methods are used to measure layer thickness, depth, and the shear wave velocity ( $V_s$ ) of the layer. The shear wave velocity is more of bulk (general) velocity than a discrete velocity of a layer. Discrete shear wave velocity may be determined by crosshole or downhole methods. While the SASW will typically have two geophones, the MASW will have additional geophones spread over a larger area. Typically, SASW and MASW profiles are limited to a depth of approximately 130 feet using man-portable equipment. Additional depth can be obtained, but heavier motorized equipment is required.

### 5.8 IN-SITU SOIL TESTING

The testing described in this section provides the Geotechnical Engineer with soil and rock parameters determined in-situ. This is important on all projects, especially those involving soft clays, loose sands, and/or sands below the water table, due to the difficulty of obtaining representative samples suitable for laboratory testing. For each test included, a brief description of the equipment and test method is presented. While this section covers some of the more common tests performed at MDOT, others may also be useful in the field investigation and can be considered by the GSS or region soils engineer on a case-by-case basis.

#### 5.8.1 STANDARD PENETRATION TEST (SPT)

The Standard Penetration Test (SPT) is performed during the advancement of a soil boring to obtain an approximate measure of soil resistance, as well as a disturbed soil sample with a split-barrel sampler. The procedures for the SPT are detailed in ASTM D1586.

Generally, all borings should be performed with split-spoon sampling. Split-spoon samples must be obtained with a standard spoon of 2 inches O.D. and 1.5 inch I.D., and advanced by dropping a 140-pound hammer on the drill rod from a height of 30 inches. The sampler is typically advanced a total of 18 inches. The number of blows required to advance the sampler for each of the three 6-inch increments is recorded. The sum of the number of blows for the second and third increments is called the N-value.

Various types of hammers have historically been utilized to perform the SPT, including donut, safety, and automatic hammers. Currently, safety and automatic hammers are utilized with the automatic hammer being the preferred hammer of choice by MDOT. Field investigations should use an automatic hammer unless site or project conditions warrant otherwise. The use of a

donut hammer is not permitted. Hammers utilized on an MDOT funded project must be calibrated in accordance with ASTM D4633 *Standard Test Method for Energy Measurement for Dynamic Penetrometers*. Hammer calibration must have been conducted within two years from the start of drilling the project or after hammer adjustment/repair, whichever criterion is more stringent. The energy ratio result of the calibration test should be provided in the geotechnical report. This information allows the Geotechnical Engineer the opportunity to apply hammer energy corrections to the field N-values as deemed applicable.

The SPT values should not be used indiscriminately. They are sensitive to the variations in individual drilling practices and equipment. Studies have also indicated that the results are more reliable in sands than clays. In addition, SPTs conducted in gravel, cobbles, and boulder formations can result in elevated blow counts that are not necessarily representative of the actual subsurface conditions. Although extensive use of this test in subsurface exploration is recommended, it should be augmented by other field and laboratory tests, particularly in clay profiles.

### 5.8.2 CONE PENETROMETER TEST (CPT)

The Cone Penetrometer Test (CPT) is a quasi-static penetration test in which a cylindrical rod with a conical point is advanced through the soil at a constant rate and the resistance to penetration is measured. A series of tests performed at varying depths at one location is commonly called a sounding. Although not widely used on transportation projects for MDOT, special circumstances may find the use of this test beneficial. Tests must be performed in accordance with ASTM D5778 - *Standard Test Method for Performing Electronic Friction Cone and Piezocone Penetration Testing of Soils* (electro-piezocones). The use of this method must be approved by the GSS.

The penetrometer data is plotted showing the tip stress, the friction resistance, and the friction ratio (friction resistance divided by tip stress) vs. depth. Pore pressures can also be plotted with depth. Ideally, these results can be graphically presented adjacent to the soil profile for that specific location. The results should also be presented in tabular form indicating the interpreted results of the raw data.

### 5.8.3 DYNAMIC CONE PENETROMETER TEST (DCP)

This test is similar to the cone penetrometer test except, instead of being pushed at a constant rate, the cone is driven into the soil similar to the SPT. The number of blows required to advance the cone in selected increments is recorded. The increment determination is dependent on the purpose of obtaining the test data. The DCP test is typically utilized at shallow depths (5 ft) in pavement investigations as design methodology trends toward the direction of a mechanistic design approach.

Tests can be performed continuously to the depth desired with an expendable cone, which is left in the ground upon drill rod withdrawal, or they can be performed at specified intervals using a retractable cone and advancing the hole by auger or other means between tests. Samples are not obtained.

Blow counts are generally used to identify material type and relative density. However, while correlations between blow counts and engineering properties of the soil exist, they are not as widely accepted as those for the SPT. Furthermore, available correlations are based on an instrument with specific size and weight parameters. Since there are currently various models available that have different size hammers, drop heights, cone diameters and cone tip angles, the user should ensure the proper device is being used for the appropriate testing purpose and data correlation. These tests are conducted on a case-by-case basis and should be approved by the GSS or region soils engineer prior to use.

MDOT users must use DCP equipment with the following specifications. The DCP instrument consists of a 0.625-inch (16mm) diameter steel drive rod with a replaceable point or disposable cone tip, a 17.6-lb (8 kg) hammer that is dropped from a fixed height of 22.6 inches (575 mm), a coupler assembly, and a handle. During pavement investigations, the instrument is typically used to assess material properties down to a depth of at least 39 inches (1000 mm) below the surface. The penetration depth can be increased using drive rod extensions. The penetration rate (mm per blow) is calculated and can be used to estimate the California Bearing Ratio (CBR), to identify strata thickness, shear strength of strata, and other material characteristics. The test must be performed in accordance with ASTM 6951 *Standard Test Method for Use of the Dynamic Cone Penetrometer in Shallow Pavement Applications*. The DCP is being increasingly used in routine as well as specialized testing of unbound pavement layers and subgrade.

#### 5.8.4 DILATOMETER TEST (DMT)

The dilatometer is a 3.75-inch wide and 0.55-inch thick stainless-steel blade with a thin 2.4-inch diameter expandable metal membrane on one side. While the membrane is flush with the blade surface, the blade is either pushed or driven into the soil using a drilling rig. Rods carry pneumatic and electrical lines from the membrane to the surface. At depth intervals of 12 inches, pressurized gas is used to expand the membrane, both the pressure required to begin membrane movement and that required to expand the membrane into the soil 0.04 inches (1.1 mm) are measured. Additionally, upon venting the pressure corresponding to the return of the membrane to its original position may be recorded. Through developed correlations, information can be deduced concerning material type, pore water pressure, in-situ horizontal and vertical stresses, void ratio or relative density, modulus, shear strength parameters, and consolidation parameters. Compared to the pressuremeter, the flat dilatometer has the advantage of reduced soil disturbance during penetration. Tests must be performed in accordance with ASTM D6635 - Standard Test Method for Performing the Flat Plate Dilatometer.

These tests are conducted on a case-by-case basis and should be approved by the GSS prior to use.

#### 5.8.5 PRESSUREMETER TEST (PMT)

The pressuremeter measures stress/strain properties of soils by inflating a probe placed at a desired depth in a borehole. The PMT provides much more direct measurements of soil compressibility and lateral stresses than do the SPT or CPT. Results are interpreted based on semi-empirical correlations from past tests and observation. In situ horizontal stresses, shear strength, bearing capacities, and settlement can be estimated using these correlations. The PMT is a delicate tool and is very sensitive to borehole disturbance. This test requires a high level of technical expertise to perform and is relatively time consuming. Tests are completed in accordance with ASTM D4719. Further guidance into the use of this instrument can be located in FHWA-IP-89-008 *The Pressuremeter for Highway Applications*. These tests are conducted on a case-by-case basis and should be approved by the GSS prior to use.

#### 5.8.6 FIELD VANE TEST

This test consists of pushing a four-bladed vane at the base of a borehole into very soft to medium stiff cohesive soil or organic deposits to the desired depth and applying a torque at a constant rate until the material fails in shear. The torque measured at failure provides the undrained shear strength. A second test run immediately after remolding at the same depth provides the remolded strength of the soil and soil sensitivity. Tests must be completed in accordance with ASTM D2573 (AASHTO T 223). These tests are conducted on a case-by-case basis and should be approved by the GSS prior to use.

#### 5.8.7 FALLING WEIGHT DEFLECTOMETER (FWD)

A deflectometer is a portable apparatus used to determine the stiffness of base and subbase materials during pavement design by measuring the deflection under an applied load or, in simple terms, to ensure the in-place foundation materials are compacted enough to provide a stable foundation for the pavement.

The device is either mounted on a trailer or truck bed and takes measurements of the deflection of the compacted soils impacted by a falling weight. It measures deflection and estimates a modulus value based on the force required to generate a given deflection for that soil type. These tests can be used to obtain subgrade resilient modulus values for pavement design or are sometimes used to detect potential voids below the roadway. In addition, the use of FWD tests are conducted on a case-by-case basis and should be approved by the region soils engineer prior to use.

## 5.9 FIELD INSTRUMENTATION

### 5.9.1 GENERAL PURPOSE

Every geotechnical design involves uncertainties and every construction job involving soil or rock runs the risk of encountering surprises because of uncertain soil conditions or soil behavior. These circumstances are the result of working with materials created by nature, which seldom provides uniform conditions. The inability of exploratory procedures to detect all possible properties and conditions of natural material requires the Geotechnical Engineer to make assumptions and select equipment and construction procedures without full knowledge of what might be encountered. Field instrumentation can reduce these uncertainties and can aid in the selection of appropriate field equipment and construction procedures.

Field instrumentation is typically utilized during two stages of project development, either during the design phase or the construction phase. During the design phase, field instrumentation can be utilized for the following purposes:

- Definition of initial site conditions
- Establish the behavior of geologic formations when loaded or unloaded
- Confirmation of foundation response through performance or proof testing
- Fact finding at a failure or emergency situation

The most common deployment of field instrumentation monitoring is during construction. In this phase, instrumentation can be utilized to address the following situations:

- Validate engineering design assumptions
- Construction control
- Liability protection
- Research or advance the state-of-the-practice
- Safety

The objectives for instrumentation during construction will change depending on the size and type of construction, the geotechnical conditions and the project schedule. Some types of instrumentation monitoring are a required part of construction (e.g., testing of tieback anchors, testing of micropiles). Other types of instrumentation monitoring should only be implemented if construction durations are sufficiently long to make the data collection useful or relevant. Preload (surcharge) monitoring is an example of this category.

After establishing a clear set of objectives, the Geotechnical Engineer identifies the potential need for instrumentation monitoring and communicates the preliminary instrumentation plans with the MDOT project manager to confirm that the objectives of the instrumentation work are justified and fit within the project scope or construction plans. In the case of plan development, the use of field instrumentation will require development of a special provision. The special

provision must describe, at a minimum, the type of equipment to be utilized, frequency of measurements, qualifications of personnel, and type of frequency of reporting required.

The following sections highlight commonly used field instrumentation. Additional information and guidelines for selecting, installing, monitoring, and interpreting instrumentation data can be found in the Federal Highway Administration (FHWA) *Geotechnical Instrumentation Manual*, FHWA, HI-98-034. In addition, companies selling instrumentation typically have detailed information describing these guidelines as well.

### 5.9.2 INCLINOMETERS

These instruments are used to monitor the magnitude, direction, and rate of subsurface deformations. Typical applications include monitoring the rate and extent of horizontal movement of embankments or cut slopes, determining the location of an existing failure surface, and monitoring deflection of retaining walls. They are also used to measure deformation during lateral load testing of deep foundations.

Inclinometers can be installed at several levels on an embankment or cut slope to define the extent and nature of subsurface movements. An inclinometer consists of a grooved casing grouted vertically in a borehole. The role of the casing is to deform with the surrounding ground such that readings taken within the casing reflect accurate measurements of ground movement. Typically, the grooves are aligned parallel to the direction of movement. The probe is periodically inserted down the casing and deflection of the casing is measured. The inclinometer probe contains accelerometers at either end to measure the parallel and perpendicular tilt of the casing. Successive measurements are plotted to provide a chronological indication of the extent and rate of subsurface movements.

Installation of inclinometer casing must be continued sufficiently into material that is not expected to deform. This will provide a point-of-fixity at the bottom of the casing to which other measurements through the casing can be reliably correlated to.

### 5.9.3 SETTLEMENT INDICATORS

These instruments are used to record the amount and rate of settlement under load. The most common installation of these instruments is for use with embankments where high settlements are predicted. In these situations, the load from the new embankment causes compression in the underlying soil, resulting in settlement at the roadway surface or in adjacent areas. While monitoring the vertical settlements of embankments is most common, vertical settlements may also need to be monitored for bridges on spread footings or piles, drainage culverts, or natural hillsides as an indicator of slope movement. The instruments detailed below identify the most common instrumentation types for monitoring vertical deformation of structures and embankments. A special provision for use of these devices must be developed based on site and project conditions and included in the contract documents.

#### 5.9.3.1 Settlement Plates

One of the simplest forms of a settlement indicator is the settlement plate, which typically consists of a steel plate placed on the ground surface prior to embankment construction. A reference rod and steel protective casing are then attached to the plate. As fill placement progresses, additional rods and casing are added and a measurement taken.

Settlement plates are to be placed at those points under the embankment where maximum settlement is predicted, or other points of interest. The platform elevation must be recorded before embankment construction begins. This is imperative because all future readings will be compared with the initial reading. Plotting of the data is then plotted as a function of time. Upon review of this data, the Geotechnical Engineer will determine when the rate of settlement has slowed sufficiently for construction to continue.

#### 5.9.3.2 Pneumatic Settlement Cell

Another way to monitor settlement during construction is with a pneumatic settlement cell. This system consists of a reservoir, liquid-filled tubing, and a pressure transducer attached to a settlement plate.

The transducer measures the pressure created by the column of liquid in the tubing. As the transducer settles with the surrounding ground, the height of the column is increased and the transducer measures higher pressure. Settlements are calculated by converting the change in pressure to inches of liquid head.

#### 5.9.3.3 Benchmarks and Heave Stakes

Settlement benchmarks are installed on structures or embankments upon essential completion of construction or in an excavation to determine vertical deformations. Place physical targets, such as a PK nail, a sturdy stake, or simply a painted mark on a wall, to measure settlement. Use conventional elevation survey techniques to determine changes in elevation. To serve as a reference monument, ensure the benchmark is located outside the area that is loaded or unloaded. Collection of reference data in advance of any work to establish a sufficient baseline condition is preferred.

#### 5.9.3.4 Crack Gauges

Crack gauges refer to simple commercial devices installed over a crack in a structure, such as a retaining wall, to visually monitor relative vertical and horizontal movements. Crack gauges permit visual monitoring and measurement of structural movements without requiring the use of survey equipment. Several configurations of the gauges are

available, such as gauges mounted on a flat surface or gauges mounted on either side of a corner.

Crack gauges have some limitations, and their use requires judgment and experience. Crack gauges are typically only capable of monitoring movement in two dimensions; therefore, multiple gauges mounted at several locations on the structure will be required to monitor movement in three dimensions.

#### 5.9.4 PIEZOMETERS

The term piezometer is generally used to describe an instrument where seals are placed within the ground at selected depths to monitor pore pressure conditions only within a certain stratum. Piezometers are used to measure the groundwater head at a specific depth. The layout and target depths of piezometer installation are determined by actual site conditions and project requirements. Typical uses include monitoring of embankment construction, measuring groundwater in a landslide situation, or determining the hydrostatic head of a confined aquifer.

The simplest type of piezometer is an open standpipe piezometer. Open standpipe piezometers have a slower response time than some of the more sophisticated instruments but are generally more cost effective to install and are more reliable than other methods. Where fast response to pore pressure changes is desired, the use of more sophisticated instruments, such as a vibrating wire or pneumatic piezometers, should be considered by the Geotechnical Engineer.

For monitoring filling activities, the critical levels to which the excess pore pressure will increase prior to failure can be estimated during design. During construction, vibrating wire or pneumatic piezometers are typically used to monitor the pore water pressure buildup. After construction, the dissipation of the excess pore water pressure over time is used as a guide to consolidation rate. Thus, piezometers can be used to control the rate of fill placement during embankment construction over soft soils.

Piezometers should be placed prior to construction in the strata in which problems are most likely to develop. The pore water pressure should be checked often during embankment construction. After the fill is in place, it can be monitored at a decreasing frequency. The data should be plotted (as pressure or feet of head) as a function of time. A good practice is to plot pore water pressure, settlement, and embankment elevation on the same time-scale plot for comparison.

Piezometers are to be abandoned in accordance with EGLE guidelines.

#### 5.9.5 MONITORING WELLS

A monitoring or observation well is used to monitor “long-term” groundwater levels or to provide ready access for sampling to detect groundwater contamination. It consists of a

perforated section of pipe or well point attached to a riser pipe, installed in a borehole with the annulus filled with sand, and then appropriately sealed. Installation and decommissioning of monitoring wells must be in accordance with EGLE requirements.

#### 5.9.6 TILTMETERS

Tiltmeters are used to monitor the change in vertical inclination of points on the ground or on structures. Typical highway applications include monitoring the tilt of mechanically stabilized earth or conventional retaining walls and bridge columns. The complexity of tiltmeters can range from relatively simple instruments, based on a plumb line or bubble level, to more sophisticated devices equipped with accelerometers, which are housed inside a protective cover. Two common transducer types are servo-accelerometers and pendulum and vibrating-wire setups. Tiltmeters can either be permanently affixed to a structure or be portable. For the portable versions, a reference plate is attached to the structure and the portable instrument is attached to the plate in a repeatable position and the reading is obtained. The portable tiltmeter can be used to measure tilt biaxially by rotating the instrument 180 degrees on the reference plate and taking another reading. Fixed tiltmeters can also be used biaxially by installing two transducers on the same bracket at 90-degree angles to one another.

It is imperative that the tiltmeter reference plate or mounting bracket is attached securely to the structure that is to be monitored. Tiltmeters are typically cemented or screwed into place. A limitation of tilt measurements is that they tend to be more localized than with other types of field instrumentation. Extrapolating tilt measurements across a structure involves assumptions about the rigidity of the structure and, therefore, can be very difficult. For this reason, tiltmeters are generally used in conjunction with other deformation measurement methods such as inclinometers or surveying points.

#### 5.9.7 VIBRATION MONITORING

Some projects require that ground vibrations be monitored during construction. The two most common examples of vibration monitoring occur with installation of driven piles and blasting for rock excavation. The vibrations caused by pile driving or blasting can be damaging to nearby structures, utilities, or bothersome to people who feel the vibrations. This is especially true of historic structures and structures constructed over poor soils. Other sources of vibrations encountered on a construction project to be considered by the Geotechnical Engineer include vibratory compactors, large equipment, demolition, and sheet pile installation.

If vibration monitoring is deemed necessary during construction, the contract documents are to include a special provision covering this topic. The special provision should specify the type of monitoring, the sensitivity, frequency, duration of the monitoring, and in some cases, the maximum permissible vibration levels.

### 5.9.8 OTHER SPECIAL INSTRUMENTATION

Situations may arise where field instruments, other than those described above, and automated data acquisition systems are desired for use on a project. The need for special instrumentation and the selection of instruments will be evaluated on a case-by-case basis with the GSS.

### 5.9.9 INTERPRETATION AND REPORTING

For guidance on the data interpretation process, refer to the aforementioned references. Product manufacturers typically provide useful guidelines on the data interpretation process.

In general, field instrumentation reporting will consist of two phases, interim monitoring reports and a final report of a monitoring program. The reported information must adhere to the contract special provision or project scoping document. The Geotechnical Engineer is to distribute copies of these reports to all the parties, as determined during development of the field monitoring plan.

#### 5.9.9.1 Qualifications of Personnel

All personnel involved in the installation, collection, and interpretation of instrument data must be familiar with the instrumentation being used. These personnel must be familiar with the installation report so that, if anomalies are encountered, they can provide feedback to the engineers processing the data. In addition, personnel obtaining the data must report to a licensed engineer experienced in the interpretation of the specific type of data being collected. In the case of settlement readings, a licensed land surveyor may be required. The qualifications of all personnel involved with the installation, calibration, maintenance and data collections must comply with the requirements as directed by the special provision. Specific qualifications for a specific type of instrumentation used on a specific project should be outlined within the special provision.

## 5.10 SURVEY

The level of survey and oversight required for geotechnical tasks, other than locating soil borings, will be determined by the GSS or region soils engineer on a case-by-case basis. The level of oversight and survey control used for determining the location and elevation of soil borings must be in accordance with Section [6.2.3](#). The requirement details for other geotechnical-related survey tasks will be provided in the scope of service or special provision documents.

## 5.11 APPENDIX 5

## 5.11.1 APPENDIX 5.1

## Recommended Practice For Plugging Soil Borings

This document is intended to supplement "Recommended Practice for Soil Borings", Manual No. 1 as issued by the Southeastern Branch of the Michigan Section of the American Society of Civil Engineers in April, 1969. The purpose of this document is to outline recommended practice for the backfilling, plugging, and sealing of test borings. The methods recommended herein, or as amended, are intended to restore the area of the test borings to its original condition in order to prevent migration of fluids or gases from one strata to another and to minimize the possibility of surface or sub-surface pollution. These methods have been tested and found effective in the Great Lakes area under most conditions. Where conditions are such that the methods presented herein are not applicable, supplemental procedures should be employed under the direction of a qualified Engineer.

- 1.0 Drilling Soil Borings - Soil borings shall be made in accordance with the "Recommended Practice of Soil Borings" mentioned above. Drilling may be by any of the methods specified therein subject to the limitations set forth for each method.
- 2.0 Plugging Soil Borings - The plugging of soil borings shall be accomplished in accordance with the methods set forth herein. On the basis of the field logs prepared during the drilling of the boring, the hole shall be assigned to one of the categories listed below and the appropriate plugging method utilized.

SOIL BORING CATEGORIES AND PLUGGING METHODS	Natural Soil	Cement Grout	Pressure Cement Grout	Bentonite
Boring through Sand above or to Bedrock				
A. No ground water	Yes (7)			
B. Ground water	Yes (7)			
Boring through Sand into Bedrock				
A. No ground water	Yes (7)			
B. Ground water		Yes (1)		
C. Water in rock		Yes (1)		
D. Artesian water in rock			Yes (1)	
Boring through Clay above or to Bedrock				
A. No ground water	Yes (7)			
B. Ground water	Yes (7)			
Boring through Clay into Bedrock				
A. No ground water	Yes (7)			
B. Ground water				Yes (7)
C. Water in rock		Yes (1)		
D. Artesian water in rock			Yes (2)	
Boring through Clay above Sand, to or into Bedrock				
A. No ground water	Yes (7)			
B. Ground water in sand or rock		Yes (3)		Yes (3)
Boring through alternate strata of Sand and Clay				
A. One layer of sand	Yes (7)			
B. One layer of clay				Yes (4)
C. Several alternate layers				Yes (4)
Borings encountering Artesian Water		Yes (8,5)	Yes (6)	
Borings encountering Gas, Coal, Sulphurous or other noxious substances at any depth		Yes (8,5)	Yes (6)	

Figure 3: Recommended Practice for Plugging Soil Borings

1. Grout to top of rock.
2. Grout to minimum 5 feet above rock:
3. Grout to minimum 5 feet above sand.
4. Backfill to top of top clay stratum.
5. Grout entire boring.
6. Pressure grout at source
7. Fill entire hole.
8. Place plug to elevation near source and grout remainder of hole.

**GROUND WATER** shall mean water that is free to move through a soil mass under the influence of gravity. **SAND** shall mean any predominantly granular material which will permit the flow of ground water. Includes silty sand, gravel, cinder fill, etc. **CLAY** shall mean any predominantly fine-grained material which is relatively impermeable and which will not permit the flow of ground water. Includes silt, silty clay, sandy clay, etc. **NATURAL SOIL** shall mean material that is removed from the drill hole. **ARTESIAN WATER** shall mean any water which rises above the level at which it is encountered. **CEMENT GROUT** shall mean Portland cement mixed with sufficient water to provide suitable consistency for placing or pumping. **PRESSURE GROUTING** shall mean injecting cement with a positive displacement pump, or other suitable devices which will maintain a pressure higher than the artesian head. **BENTONITE** shall mean any properly processed expansive colloidal clay. Cement grout may be used in lieu of Bentonite.

Borings drilled through soils or rock with profile not described in the foregoing categories must be effectively sealed to prevent movement of water between aquifers, or leakage at ground surface.

### 3.0 Special Cases

3.1 Piezometer or Standpipe Installation—Where required by the Engineer or owner, a piezometer or standpipe shall be installed in the test boring upon completion of drilling. The piezometer or standpipe shall be sealed in a manner consistent with the requirements for such installation and, insofar as practicable, in conformance with the plugging methods set forth in Section 2.0 above. At such time as the piezometer is no longer required, it shall be sealed by grouting or by other appropriate means.

3.2 Holes Not Plugged — Where the requirements of the owner or Engineer dictate that holes shall be left open, casings shall be left in place to prevent caving of the holes or migration of fluids or gases from one stratum to another. At such time as the requirement to maintain the hole open ceases, the hole shall be plugged in accordance with the methods specified in 2.0 above.

4.0 Plugging records - The drillers' field notes and borings log shall include the following information regarding the plugging of the borings:

- A. Plugging method utilized.
- B. Quantities of Bentonite, grout, or other material utilized in plugging.
- C. Any unusual conditions encountered during plugging such as excessive take of grout materials, leakage exterior of casing, etc.
- D. State if casing was placed and left in hole.

## ACKNOWLEDGEMENT

These recommendations were prepared by a sub-committee appointed on September 22, 1971, at a regular meeting of the Soil Mechanics and Foundation Committee, Southeastern Branch, Michigan Section, American Society of Civil Engineers. The effort of many individuals and organizations who assisted the committee is gratefully acknowledged. The following individuals have participated most directly in the preparation: Grover W. Fox, Sub-Committee Chairman; Raymond P. Elliott, P.E.; Kenneth W. Kramer, P.E.; Jerome C. Meyer, P.E.; J. N. Hargrave-Thomas; Harley Corbin; Khalid Hindo, P.E.; Garrett H. Evans, P.E., Technical Group Chairman, 1970.

Figure 3 continued: Recommended Practice for Plugging Soil Borings Continued

## SECTION 6 – SUBSURFACE INVESTIGATION GUIDELINES

### 6.1 INTRODUCTION

A subsurface investigation is required for new or replaced structures and roadway alignments involving earthwork. Examples of this include bridge replacements, widening of existing bridges and roadway realignments (permanent and temporary), retaining walls, box culverts, overhead sign structures, sound barrier walls and other miscellaneous structures.

This section presents guidelines to plan a subsurface investigation. Since requirements will vary with project conditions, engineering judgment is essential in tailoring the investigation to the specific project. The Geotechnical Engineer uses available soils and geologic maps, water well records, existing reports, plans and boring logs, publications, aerial photographs, and other reference material that are available to prepare a preliminary subsurface investigation. Borings should then be selectively located during a field check attended by the Geotechnical Engineer or an appointed representative.

The actual location, spacing, and depth of borings are dictated by the topography, geologic conditions, visible soil conditions, design considerations, existing utilities, and in accordance with the practices set forth herein.

The investigation should provide sufficient data for the Geotechnical Engineer to recommend the most efficient design. Without sufficient data, the engineer must rely on conservative designs, which may cost considerably more than a site-specific exploration program.

A comprehensive subsurface investigation might include both conventional borings and other specialized field investigatory or testing methods. While existing data can provide some preliminary indication of the necessary extent of exploration, more often it will be impossible to finalize the investigation plan until some additional field data is collected. Therefore, close communication between the Geotechnical Engineer and driller/field engineer is essential. The results of preliminary borings should be reviewed as the investigation is ongoing so that additional borings and in-situ testing, if necessary, can be performed without remobilization.

### 6.2 GENERAL REQUIREMENTS

#### 6.2.1 SPACING AND NUMBER OF BORINGS

On new alignments, borings are sometimes made in two or more stages. In the planning/scoping stage, relatively few borings are made to assist in the selection of preferred alignment, bridge/structure location and length, and to identify areas requiring further exploration in the subsequent stage(s). Based upon these findings, additional borings may be made between the initial borings to define soil conditions in greater detail. The selection of sample type and frequency is determined by soil conditions and design and construction requirements for the

structure. Where soil conditions are favorable, especially for small structures or roadway investigations, all borings are often completed in the first phase of the investigation. The spacing, depth, and number of borings should be in accordance with Section [6.3](#) so that soil conditions are adequately characterized. However, if soil conditions vary appreciably, more closely spaced or deeper borings may be required. The spacing, depth, and number should be determined by engineering judgment as the work progresses. There should be a sufficient number of borings to determine the stratification and interrelation of the soils to the extent economically feasible. The exploration should be conducted considering the requirements of the structure or roadway. All subsurface data necessary for the selection of the foundation or roadway quantities and their design must be obtained.

### 6.2.2 CONSULTANT GEOTECHNICAL ENGINEER

Consultant Geotechnical Engineers must submit to the MDOT project manager for review and comment a detailed subsurface investigation plan prior to the commencement of any field operations. The plan must describe the soil or rock stratification anticipated as the basis of the planned exploration. In the plan, outline proposed testing types (borings/soundings), depths, boring equipment, and locations of all testing. The consultant's subsurface investigation plan must conform to the requirements of the Manual. Frequently, explorations are conducted in sensitive environmental areas or in high hazard traffic areas. The consultant's exploration plan must describe any special access requirements or traffic control requirements necessary to protect MDOT's interests during the field investigation phase. The consultant is responsible for all special access requirements, permits, and traffic control. All traffic control must conform to the approved maintenance of traffic permit.

### 6.2.3 MISCELLANEOUS

The extent of the exploration will vary considerably with the nature of the project. However, the following general standards apply to all investigation programs or as appropriate for the specific project and agreed upon by the Geotechnical Services Section (GSS) or region soils engineer.

1. All borings for bridge foundation design must extend below the estimated scour depths.
2. All borings must extend below the foundation.
3. Each boring, sounding, and test pit should be given a unique identification number for easy reference. Generally, the borings should be numbered in chronological order with lower number borings starting at the lower stations. Reference Section [10.2.1](#) for soil boring naming conventions.
4. The ground surface elevation and actual location must be accurately determined for each boring, sounding, and test pit by qualified personnel who are trained in the use of the required equipment. Locate each item by survey, use conventional survey methods and/or a Global Positioning System unit certified by the manufacturer to submeter accuracy. Survey data transmitted to the individual boring logs and soil boring data sheet must include station, offset, elevation, northing, easting, longitude, and latitude.

Coordinates must be in the Michigan State Plane Coordinate System (NAD 83) and elevations in the Vertical Datum (NAVD 1988). Longitude and latitude coordinates must be reported in the WGS 1984 Datum. Vertical elevations should be reported within an accuracy of 0.1 ft. These methods and accuracies must be followed unless otherwise approved by the project manager.

5. A sufficient number of disturbed and undisturbed samples, suitable for the types of testing and analyses intended, should be obtained within each layer of material. SPTs must be taken at 5 ft intervals unless noted otherwise. Conduct sampling and in-situ testing in accordance with ASTM D1586, ASTM D1587, and ASTM D2113.
6. All soil samples recovered during the subsurface exploration must be labeled, preserved, and transported in accordance with ASTM D4220. Refer to Section [5.6.6.5](#) for further guidance on rock core samples.
7. For all overhead sign, high mast lighting, mast arms, strain poles, closed circuit television camera (CCTV) poles, environmental sensor station, cable barrier and sound wall structures, boring locations must be within 10 ft of the foundation footprint. If the proposed foundation is in an area not accessible to a machine boring meeting this criterion, one hand boring to a target depth of at least 7 ft must be taken within the footprint of the foundation and one auger boring taken at the closest point of access. It is highly desirable to have the hand auger and machine boring overlap so that a continuous profile can be achieved.
8. When rock is encountered during the field investigation, the minimum depth of exploration must be equal to the maximum expected foundation depth plus 5 ft.

#### 6.2.3.1 Groundwater Observations

Measure and record groundwater levels within each boring or test pit when first encountered, at completion of drilling, and after sufficient time has elapsed for the groundwater level to stabilize. An elapsed time of 24 hours is commonly utilized for structure investigations. If more than one day is required to complete a boring, measure and record the depth of the boring and groundwater level at the end and beginning of each day. Hole collapse, if applicable, should also be noted on the boring log.

In addition, drilling or flushing fluids introduced into the borehole that may affect the groundwater readings must be recorded on the boring logs. Drilling methods utilized during the field investigation may affect the accuracy of groundwater level readings. Therefore, the Geotechnical Engineer should carefully consider the drilling methods utilized so that accurate groundwater information is obtained. Regardless of drilling methods utilized, the Geotechnical Engineer is responsible for accurate depiction of the groundwater level(s) at the time of the investigation. Installing a monitoring well or drilling with augers for a certain distance may be necessary to accurately depict the groundwater level.

If artesian conditions are encountered that may affect the design and construction of the geotechnical item being investigated, then long-term monitoring with monitoring wells and/or piezometers will likely be required. Reference Section [6.3.3.1](#) for further artesian discussion.

In addition, when drilled shafts foundations may be used on a project, long term groundwater readings will be required as part of the investigation. This entails installing monitoring wells and/or piezometers during the field investigation.

### 6.3 GUIDELINES FOR MINIMUM EXPLORATIONS

With the above general concepts in mind, the following guidelines for location and depth of borings should be followed. In addition to the guidelines below, the number and depth of borings must be adequate to assess overall stability.

#### 6.3.1 STRUCTURES

##### 6.3.1.1 Bridges

For all bridges, at least one boring must be taken at each substructure unit location. Borings should be taken at opposite sides of adjacent substructure locations when practical. Additional requirements are indicated below.

- For bridge substructures that are 100 feet wide and wider, an additional boring must be taken at opposite ends of each substructure.
- When spread footings are proposed on bedrock, conduct one sounding at the opposite end of the footing.
- Where highly variable conditions are anticipated or encountered, then a boring should be advanced at both ends of each substructure unit.
- See Section [6.2.3.1](#) for groundwater observations discussion.

If part-width (staged) construction is a potential design scenario, then the Geotechnical Engineer should consider locating a boring at/near the stage line so that the contractor has sufficient soil data for design of the temporary earth retention system.

The minimum sampling frequency is every 5 ft in depth where an SPT is obtained. In cases where spread footings are proposed, increase SPT frequency to 2.5 ft directly below the bottom of footing elevation to a minimum of 1.5 times the footing width B. When cohesive materials are encountered that indicate undrained shear strength values less than 2,500 pounds/square foot, representative undisturbed Shelby tube samples must be obtained for laboratory analysis. Push Shelby tubes in conjunction with or in place of SPTs for strength and consolidation testing.

If spread footings are a potential foundation support option, the borings are extended until sufficient information has been obtained to complete the bearing capacity and settlement analysis. The boring must extend to a minimum depth of 50 ft below bottom of footing elevation unless rock is encountered.

If the footing bears on bedrock, or bedrock is encountered within 1 times the footing width  $B$ , obtain a minimum 10 ft rock core to determine the integrity of the rock and to verify that the exploration was not terminated on a boulder.

For bridges on a deep foundation system supported by soil, the depth of the investigation must extend at least 20 ft below the anticipated pile or shaft tip elevation or a minimum of two times the minimum pile group dimension, whichever is greater. All borings must extend through unsuitable strata, such as unconsolidated fill, peat, highly organic materials, soft fine-grained soils, and loose coarse-grained soils, to reach hard or dense materials. For driven piles bearing on rock, a minimum 10 ft rock core must be obtained at each structure to determine the integrity of the rock and to verify that the exploration was not terminated on a boulder. For drilled shafts or micropiles that are supported on or socketed into the rock, obtain a minimum 10 ft rock core, or a length of rock core equal to at least 3 times the estimated shaft diameter, whichever is greater. Coring requirements must be sufficient to determine the physical and strength characteristics of the rock within the entire zone of foundation influence.

#### 6.3.1.2 Bridge Approach Embankments

For projects involving grade raises, widenings, or new construction, refer to Subsection [6.3.2](#) for further guidance. The Geotechnical Engineer is responsible for evaluating the effects the bridge approach design changes have on the underlying soils. The bridge approach is defined as the embankment that extends 100 ft longitudinally from the “beginning” or “end” of the bridge and extends to the toe of the front and side slopes. The bridge approach embankment classification may be extended if there are any stability or settlement issues that would affect the bridge’s performance or transition between the roadway and bridge approach embankment.

#### 6.3.1.3 Retaining Walls

At least two borings are required for each retaining wall unless the wall length is less than 50 ft. Exploration points must be spaced at a maximum of 200 ft along the alignment of the wall. For anchored or tieback walls, perform additional borings in the anchored or tieback zone at a maximum spacing of 200 ft offset from the borings along the wall alignment (see [Figure 4](#)). For soil nail walls, additional soil borings must be conducted behind the wall at a distance corresponding to 1.0 to 1.5 times the height of

the wall at a maximum spacing of 200 ft offset from the borings along the wall alignment.

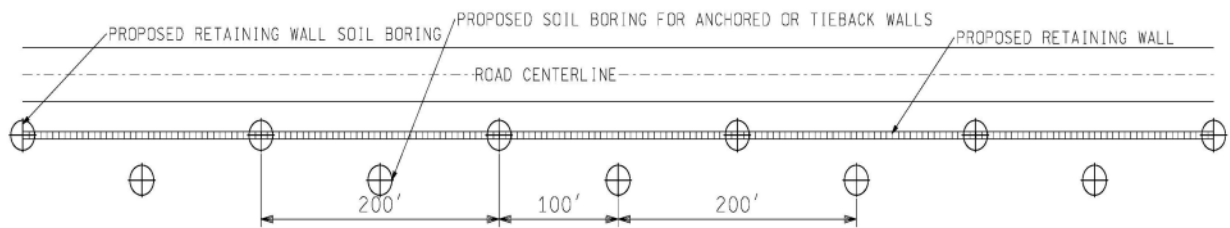

Figure 4: Soil Boring Layout for Retaining Walls

Borings must extend below the bottom of the wall a minimum of twice the wall height or auger refusal, whichever is shallower. If the wall bears on or slightly above bedrock, a minimum of one 10 ft rock core must be conducted at each site to determine the integrity and load capacity of the rock. Additional rock soundings must be conducted between borings performed at the wall alignment to profile the rock surface. All borings must extend through unsuitable strata, such as unconsolidated fill, peat, highly organic materials and soft fine-grained soils, to reach hard or dense materials. This applies to all earth retaining structures, proprietary systems as well as precast and cast-in-place. Refer to Section [6.3.1.1](#) for boring requirements on structures supported by deep foundations.

Increase SPT frequency to 2.5 ft directly below the retaining wall footing for a depth of either 10 ft or 1.5 times the footing width B, whichever is more.

#### 6.3.1.4 Culverts

All structures considered culverts will have a C## of Control Section designation while a bridge will have a B##, R##, or S## of Control Section designation assigned to it (e.g., C02 of 33082). In general, culverts are defined by having spans less than 20 ft. All new culverts must have a minimum of two soil borings taken along the alignment and hand augers at the headwalls/aprons. For culverts under divided freeways, a total of three soil borings are required with one boring performed in the median. If stage construction is planned, additional borings may be required near the stage line. Culvert extensions must have a minimum of one soil boring at each extension and hand augers at the headwall/aprons. Foundation investigation with SPTs is required for culverts 60 inches in diameter or greater. Soil borings with SPTs must also be conducted for box or slab culverts equal to or greater than 48 inches in width. Soil borings must extend to a depth beneath the anticipated invert elevation of at least 20 ft or twice the height of added embankment, whichever is greater.

Machine or hand auger borings with hand soundings may be necessary for culverts or culvert extensions smaller than the sizes specified above. Contact the region soils engineer or MDOT project manager for further guidance.

#### 6.3.1.5 Overhead Sign Structures

Truss signs and cantilever signs are commonly encountered on highway structures. Standard plans have been developed for these structures that contain standard foundation designs for each of these structures. The foundation designs provided on the standard plan are based on an assumed set of foundation soil properties, groundwater conditions, and other factors. These soil properties and conditions must be met in order to use the foundation design shown on the standard plans. If these conditions are not met (such as bedrock, organic soils, very soft soils), then a site-specific design will be required.

The subsurface investigation for these structures must be sufficient to determine whether the subsurface and site conditions meet the requirements shown on the standard plans or site-specific designs. The standard plans are located on MDOT's [Traffic & Safety](#) Minimum investigation guidelines are provided below.

- *Non-Cantilever Truss Signs* – One soil boring to a minimum depth of 50 ft at each foundation location. If “low clay” is encountered, deeper soil borings are required.
- *Cantilever Signs* – One soil boring to a minimum depth of 40 ft at each foundation location. If “low clay” is encountered, deeper soil borings are required.
- If bedrock is encountered, rock cores must be taken to a depth below the anticipated foundation depth of at least two times the diameter of the shaft or one times the width of the spread footing.

#### 6.3.1.6 High Mast Lighting

Conduct one soil boring at each high mast location. Advance the boring to a minimum depth of 35 ft unless unsuitable soils are encountered. Conduct sampling and SPTs at 2.5 ft intervals to 20 ft and then 5 ft intervals thereafter to the boring termination depth. If bedrock is encountered, rock cores must be taken to a depth below the anticipated foundation depth of at least the diameter of the shaft.

#### 6.3.1.7 Strain Poles

Advance one soil boring to a minimum depth of 30 ft at each strain pole foundation location unless low clay is encountered. If low clay is encountered, advance the soil boring to a minimum depth of 40 ft. Verify that the soil strength properties meet or exceed the soil strength properties outlined on the standard plans. These plans are located on the [Traffic and Safety](#) web page. Conduct sampling and SPT's at 2.5 ft intervals to 20 ft then 5 ft thereafter to the boring termination depth. If bedrock is

encountered, rock cores must be taken to a depth below the anticipated foundation depth of at least the diameter of the shaft.

#### 6.3.1.8 Mast Arms

Advance one soil boring to a minimum depth of 25 ft at each mast arm foundation location. Verify that the soil strength properties meet or exceed the soil strength properties outlined on the standard plans. These plans are located on the [Traffic and Safety](#). Conduct sampling and SPT's at 2.5 ft intervals to 20 ft then 5 ft thereafter to the boring termination depth. If bedrock is encountered, rock cores must be taken to a depth below the anticipated foundation depth of at least the diameter of the shaft.

#### 6.3.1.9 Dynamic Message Signs (DMS), Closed Circuit Television Camera (CCTV) Poles & Environmental Sensor Station (ESS) Poles

Minimum investigation guidelines are provided below.

- For CCTV Poles, advance one soil boring to a minimum depth of 30 ft at each designated location.
- For ESS Poles, advance one soil boring to a minimum depth of 20 ft at each designated location.
- For DMSs, advance one soil boring to a minimum depth of 45 ft at each designated location.

Conduct sampling and SPTs at 2.5 ft intervals to 20 ft and then 5 ft intervals thereafter to the boring termination depth. If bedrock is encountered, rock cores must be taken to a depth below the anticipated foundation depth of at least the diameter of the shaft.

#### 6.3.1.10 Cable Barriers

One soil boring must be advanced to a depth of 20 ft at each designated end section terminal. Conduct sampling and SPTs at 2.5 ft intervals to 10 ft and then 5 ft intervals thereafter to the boring termination depth.

#### 6.3.1.11 Noise Barrier Walls

Test boring locations for noise barrier walls must be placed near the beginning and ending of the wall, at the location of major changes in the wall alignment, and at a distance of 200 to 400 ft between these locations based on the uniformity of the subsurface conditions.

Due to varying conditions (berms, slopes, etc.) that arise at these locations, boring depths should be determined based on a case-by-case basis for each project. Boring depths should consider boring access elevation in relation to the top of foundation elevation. Advance soil borings to a minimum depth of 40 ft below the top of the foundation. Conduct sampling and SPT's at 2.5 ft intervals to 20 ft then 5 ft thereafter to

the boring termination depth. If bedrock is encountered, rock cores must be taken to a depth below the anticipated foundation depth of at least the diameter of the shaft. Unsuitable soil conditions such as the low clay soil condition may require deeper borings. Reference the Michigan Noise Barrier Wall Design Guidelines for typical foundation depths used on standard walls. Due to the variations that could arise with the wall designs, reduced soil boring depths may be allowed if approved by the GSS.

#### 6.3.1.12 Buildings

The wide variability of these projects often makes the approach to the investigation of the subsurface conditions a case-by-case basis. In general, the following guidelines are provided. For more specific guidelines, refer to the Michigan Building Code.

Table 3: Minimum Number of Building Borings

Building Surface Area (ft <sup>2</sup> )	Minimum Number of Borings
<200	1
200 - 1000	2
1000 – 3000	3
>3000	4

The depth of borings will vary depending on the expected loads being applied to the foundation and/or site soil conditions. The borings should extend until sufficient information has been obtained to complete the foundation analysis. At a minimum, extend borings to a depth of 20 ft below the bottom of footing elevation, unless rock is encountered. If the footing bears on bedrock, or bedrock is encountered within 1 times the footing width B, the Geotechnical Engineer should obtain a minimum 5 ft rock core per site to determine the integrity of the rock and to verify that the exploration was not terminated on a boulder. Increase SPT frequency to 2.5 ft for a depth of either 10 ft or 1.5 times the footing width B below the bottom of footing, whichever is more.

#### 6.3.1.13 Excavations

If deep excavations are required for the project, additional borings may be required if other site borings do not adequately provide the necessary subsurface data for the design. The explorations should be carried to at least 1.5 times the depth of the excavation to determine subsurface conditions that may exist below the level of excavation. This is necessary to design a temporary shoring system and/or a dewatering system that may be required in such deep excavations. Additional borings may be required on a case-by-case basis to address overall stability.

#### 6.3.1.14 Tunnels

Investigation criteria for tunnels will need to be established by the GSS for each project on an individual basis.

#### 6.3.1.15 Boardwalks

Support for boardwalks vary depending on size parameters, intended use, and subsurface conditions at the proposed site. Typical supports consist of spread footings, driven steel or wood piles, and helical piles. Borings should be placed at each end of the boardwalk and at intermediate locations that will sufficiently identify subsurface conditions.

The depth of borings will vary depending on the expected loads being applied to the foundation and/or site soil conditions. For boardwalks on a deep foundation system supported by soil, the depth of the investigation must extend at least 10 ft below the anticipated pile or shaft tip elevation. All borings must extend through unsuitable strata, such as unconsolidated fill, peat, highly organic materials, soft fine-grained soils, and loose coarse-grained soils, to reach hard or dense materials.

For spread footings, extend borings to a minimum depth of 5 times the footing width B below the bottom of footing elevation, unless rock is encountered. If the footing bears on bedrock, or bedrock is encountered within 1 times the footing width B, the Geotechnical Engineer should verify the integrity of the rock using coring or augering methods, and to verify that the exploration was not terminated on a boulder.

#### 6.3.1.16 Other Structures

Contact the GSS for instructions concerning other structures not covered in this section.

### 6.3.2 ROADWAY

Roadway explorations are made along the proposed alignment for the purpose of defining subsurface conditions. This information is utilized in the design of the pavement section, as well as in defining the limits of unsuitable materials and recommending any remedial measures to be taken. As part of planning each roadway exploration, it is important that the Geotechnical Engineer review existing data and conduct a site reconnaissance as described in Section [5.1](#). Review of existing documentation and visiting the site can provide the Geotechnical Engineer with insight into project aspects that aid in developing a thorough and effective exploration. Upon review of this documentation and the complexity of the project, the Geotechnical Engineer in collaboration with the road designer should determine whether a two-phased exploration approach is beneficial for the project. The initial investigation phase should be conducted early enough in the design process to assist in determining the general subsurface conditions and development of preliminary concepts/plans. Based on the initial information identified in the initial phase, the second phase is refined to obtain supplemental borings and samples required for final design.

The following sections provide minimum guidelines for situations that may arise in road construction. In some cases, combining guidelines from Sections [6.3.2.1](#) and [6.3.2.2](#) may be

applicable. For situations that are not covered in these sections, contact the GSS or region soils engineer for further guidance.

### 6.3.2.1 New Roadway Alignment or Widening

Roadway projects that require a new alignment or additional lane(s) or shoulder widening must adhere to the following subsections.

#### 6.3.2.1.1 At Grade and Cuts

Several geometric configurations exist when considering cut sections in roadway design. Some common configurations encountered are symmetrical cuts on a new alignment, cuts into existing slopes to widen an existing roadway, cut-fill transitions, or cuts on an existing slope. During the planning phase, it is important that the Geotechnical Engineer consider and obtain sufficient field data to provide detailed recommendations on the subgrade and stability of the anticipated slopes. Refer to Section [9.3](#) for roadway recommendations needed in design.

In general, conduct at least one boring at intervals of 200 ft (variable conditions) to 400 ft (uniform conditions) along the slope length. For deep cuts (15 ft or greater) or where sloughing of existing cut slopes is prevalent, the boring plan should have a minimum of 3 borings along a line perpendicular to the roadway centerline or planned slope face to establish a geologic cross-section for analysis.

Extend and sample borings as follows:

- For borings in areas of little or no grade change, extend borings a minimum of 5 ft below the cut at ditch line or top of subgrade, whichever is greater. Where a stability analysis is required, extend borings a minimum of 15 ft below depth of cut at the ditch line.
- In unsuitable soils, borings should extend below grade into competent materials or to twice the depth of the cut, whichever occurs first.
- If rock is present above the minimum elevation of the cut, the rock must be cored to the full depth of the planned cut plus 5 ft.
- An understanding of the overall purpose of the boring is important when developing a sampling and field testing plan. For proposed road profiles that are close to the existing grade, profile drilling with augers to identify the soil type may be sufficient. In cases where determining the strength or compressibility of the soil is important, then SPTs and undisturbed sample collection must be conducted. For cases where the cut is greater than 15 ft or deemed critical by the Geotechnical Engineer due to the proposed soils, SPTs must be conducted at minimum intervals of 5 ft but decreasing this interval to 2.5 ft in areas of specific interest should be considered when planning the investigation.

- For new construction, collect bulk samples of the various types of cut and subgrade soils encountered throughout the project length. Bulk samples should be sufficient in quantity to perform the necessary laboratory testing. Laboratory tests will be dependent based on the depth and use of these soils. Laboratory testing to be considered, but not limited to, during the geotechnical investigation is grain size distribution, moisture-density relationship, Atterberg limits, permeability, consolidated-undrained shear test with pore pressure measurements, and California Bearing Ration (CBR) or resilient modulus testing.

#### 6.3.2.1.2 Fills

Embankments are placed in several geometric configurations during road design. Some common configurations encountered are symmetrical fills on a new alignment, fills placed to widen an existing roadway, cut-fill transitions, or fills placed on an existing slope. During the planning phase, it is important that the Geotechnical Engineer obtain adequate field data to provide detailed recommendations on settlement potential and stability of the proposed embankment slopes based on the underlying subsurface conditions.

Embankment widening projects will require careful consideration of the exploration locations. Borings near the toe of the existing fill are needed to evaluate the present condition of the underlying soils. In addition, borings through the existing fill into the underlying soil or, if overexcavation of unsuitable soil had been done during the initial fill construction, borings to define the extent of the removal should be obtained to define conditions below the existing fill.

In situations where the existing roadway was previously constructed using a swamp treatment (peat excavation and swamp backfill) and a grade raise or widening is anticipated, additional investigation must be conducted of the existing fill slopes in these areas. Historic swamp treatment details allowed the contractor to waste the peat excavation material between the proposed slope and a theoretical 1:1 line starting at the shoulder hinge point and extending to the toe of slope. Investigation in these sloped areas delineate if poor soils exist and, if so, can then be accounted for during design.

In general, place at least one boring at an interval of 200 ft (variable conditions) to 400 ft (uniform conditions) along the embankment length. For high fills (15 ft or greater) or where unsuitable soils exist, the boring plan should have a minimum of 3 borings along a line perpendicular to the roadway centerline to establish a cross-section for stability analysis.

Extend and sample borings as follows:

- A minimum of twice the proposed embankment height unless a hard cohesive or very dense cohesionless stratum or bedrock is encountered above this depth.
- In scenarios where unsuitable soil extends to deeper than twice the fill height, the boring depth should extend through the unsuitable layer into competent material or to a depth adequate for settlement analysis, whichever is less.
- An understanding of the underlying soil conditions requires appropriate sampling intervals and methods. Sampling and SPTs should be conducted at minimum intervals of 5 ft but decreasing this interval to 2.5 ft in areas of specific interest should be considered when planning the investigation. In addition, testing for strength and compressibility in fine-grained soil requires the need for undisturbed samples.

#### 6.3.2.2 Evaluation of Existing Pavement Section and Subgrade

For projects that do not entail major earthwork, such as existing roadways or roadways with proposed minor widenings, a modified subsurface investigation may be utilized. Projects that may fall into this category are reconstruction and rehabilitation of the roadway within the existing limits. Subsurface investigation requirements for pavement structure design vary with location, traffic level, and project size.

In general, conduct pavement cores and soil borings at spacing between 200 and 1000 ft based on the uniformity of the subsurface conditions, or as directed by the region soils engineer. Soil boring locations must be alternated between lanes or as directed by the region soils engineer. Consider additional borings in problem areas (e.g., heaving rutting, faulting, fatigue cracking). Borings must be advanced to a minimum depth of 5 ft. These borings are typically advanced with either manual hand augers or machine augers. If requested by the Geotechnical Engineer, SPTs and dynamic cone penetrometer tests should be conducted at the time of the investigation. Bulk samples of the subbase and base are collected, and lab testing is conducted to determine the grain size distribution.

In some investigations, particularly those projects that are reusing existing materials, samples of the base, subbase, and subgrade are collected for soil classification, moisture-density relationship (proctor), CBR, or resilient modulus testing. Unless otherwise directed by the region soils engineer, collect bag samples of the base and subbase at each boring location for soil classification purposes. In addition, bulk samples of the different subgrade soils for the entire project should be collected for laboratory testing.

### 6.3.2.3 Bedrock

Shallow rock is sometimes identified during the planning phase or unexpectedly discovered during the field investigation. In these cases, soil borings must be obtained as described in Sections [6.3.2.1](#) and [6.3.2.2](#). However, these borings may not provide adequate information in a roadway cut scenario for the road designer to establish a good estimate of rock quantities. As a result, rock soundings using power auger methods should be conducted to better delineate the surface of the rock. The following guidelines are provided.

- For single roadways, soundings should be taken at 50 to 100 ft intervals along the centerline and along both ditch lines.
- For a dual roadway, soundings should be taken at 50 to 100 ft intervals along the centerline, the centerline of the lanes, and along the outside ditch lines.
- For a dual roadway with widely divided lanes, each lane must be treated as a single roadway.

It should be noted that the tighter spacing provided is for conditions where potential nonuniform conditions exist. The greater spacing is for conditions where preliminary field data indicate that a more uniform condition exists.

In lieu of soundings, the Geotechnical Engineer should also consider geophysical techniques to determine the bedrock surface elevation. Use of these techniques will be considered by the GSS on a case-by-case basis.

In some regions throughout Michigan, the Geotechnical Engineer should be aware of potential geohazards such as karst, artesian flows, and underground mines as outlined in Section [6.3.3](#).

### 6.3.2.4 Peat Deposits, Compressible Soils, and Very Soft Soils

Borings and soundings are required in all peat deposits, compressible soils (such as marl and very soft soils), and where significant consolidation or risk of overall instability is considered possible. The following guidelines cover general conditions.

- Soundings must be taken at 50 ft intervals longitudinally and transversely to the roadway centerline on a grid pattern to establish the contour of the swamp bottom. Closer spacing of the soundings may be needed depending on the estimated embankment width, existing infrastructure surrounding the site, or the condition of the swamp bottom. If there is an appreciable change in depth between soundings, intermediate soundings and/or auger borings may be necessary to determine a true bottom profile. The soundings should extend at least 50 ft beyond an estimated toe of slope. Additional cross-section soundings will be necessary if a sloping bottom indicates a potential stability problem.

For roadways being widened in old swamp treatment areas, borings should be placed to determine if the previous swamp treatment extended to the bottom of the proposed 1:1 slope noted in the R-103 Standard Plan. In addition, soil borings/soundings are commonly taken outside this zone so that a profile can be determined and slope stability analysis conducted.

- Soundings should be conducted with the following methods: auger borings, hand auger borings, hydraulically pushed probe rod, or small diameter steel rods (peat rods).
- Locate a sufficient number of borings with SPTs to supplement the soundings and identify the vertical and horizontal extents. Soil borings should be conducted at distance intervals between 100 to 200 ft. Spacing considerations are length of organic soil area, bottom depth consistency, and type of transportation asset (roadway, retaining wall, etc.) being constructed through that area.
- Sampling and SPTs should be conducted at intervals of 5 ft decreasing to 2.5 ft near the true bottom interface. Variations from these guidelines require prior approval by the GSS or region soils engineer.
- Extend soil borings beyond the swamp deposits and a minimum of 5 ft into material that does not exhibit organic soil or very soft consistency. Extending the boring at least 5 ft minimizes the risk of a “false bottom” existing. A false bottom is where a sand layer is interbedded between organic layers but to the driller it appears that no more organic material is present beneath the sand layer.

### 6.3.3 GEOHAZARDS

Many geohazards exist throughout the State of Michigan. Several of the more common ones are discussed in the following sections. When these conditions are anticipated or unexpectedly encountered during the investigation phase of the project, an experienced geotechnical engineer may need to develop a specialized subsurface program or modify the existing one.

#### 6.3.3.1 Artesian Conditions

At times during a field investigation, artesian conditions can be encountered throughout various areas of Michigan. According to *Michigan’s Flowing Well Handbook*, artesian characteristics can be defined as water that rises to a point above the top of the aquifer. If the water also rises above the ground surface, the well is called a “flowing well” or “flowing artesian well”. The borehole should be plugged appropriately per EGLE guidelines. Since artesian conditions have the potential to affect the engineer’s design, means to determine the hydrostatic head must be included as part of the field investigation. For instance, these means could include, but are not limited to, installing representative piezometers, pressure transducers, or vibrating wire sensors and need to

be included in the price proposal if possible. For artesian conditions encountered during construction, the GSS should be contacted to provide additional guidance in this matter.

When artesian conditions are anticipated based on the review of existing documents or experience of drilling in these areas, then proper means of documenting these conditions should be considered, planned for, and implemented into the field investigation phase of the project. If artesian conditions are encountered unexpectedly, the GSS should be contacted to determine the effects these conditions could have on the project and if further investigation is warranted.

#### **6.3.3.2 Landslides – Slope Failure**

Locate borings within the top, middle, and bottom of the landslide area or as near to these locations as practical. Obtain additional offset and longitudinal borings to define the landslide limits and the bedrock surface as necessary, considering the anticipated remediation. Extend borings through overburden soils and into bedrock. If bedrock is known to be very deep, extend the borings at least 30 feet below the estimated failure surface.

If bedrock is encountered, sample a minimum of 5 ft into bedrock at each boring location. Adjust boring spacing and location, bedrock coring, and boring depth per Section 6.3.1.3 if the landslide repair will involve a retaining wall. When landslides occur, contact the GSS for additional guidance.

#### **6.3.3.3 Karst/Sinkholes (Define, Characteristics)**

Karst topography has been encountered in parts of Michigan's Upper and Lower Peninsulas. Karst features are a result of dissolution of the carbonate and evaporate bedrock units and subsequent collapse of these units. Typical karst conditions, both natural and induced, develop in soluble rocks such as limestone, dolomite, gypsum, and rock salt. These cavities are caused by solution-widening of joints and bedding planes caused by flowing groundwater. As a result, irregularities in the bedrock surface topography or voids in bedrock units may cause a collapse to occur.

Subsurface karst features must be thoroughly explored using borings and geophysical methods. The extent of the scope will be determined on a case-by case-basis. The GSS should be contacted if karst or sinkhole features are suspected or encountered.

#### **6.3.3.4 Underground Mines**

Where the roadway crosses areas of known or possible underground mining, locate borings transverse to centerline as necessary to establish the lateral extent of mining conditions. The Geotechnical Engineer should also consider surface features, geology, and mine records in determining boring locations. Where appropriate, the use of geophysical techniques in conjunction with drilling may be warranted and will be

considered on a case-by-case basis. Each program exploring underground mines must be tailored for the specific project and site conditions. Contact the GSS when mined conditions are anticipated or encountered.

#### 6.3.3.5 Hazardous Materials

Drilling activities in hazardous or potentially contaminated material may be required during the field investigation. When this information is known or determined during the planning phase, the field investigation must include appropriate sampling, drill cutting disposal, and safety protocols required for environmentally sensitive investigations. If during the field investigation unusual odors or potentially hazardous materials are encountered, the region soils engineer or GSS must be immediately notified.

Appropriate environmental staff should also be contacted when these conditions are encountered. Each scope or subsequent scope of investigation under these conditions will be determined on a case-by-case basis.

If methane gas or other flammable vapors are anticipated, appropriate monitoring equipment should be used during the field investigation. It is imperative to document these observations on the boring logs and soils report.

### 6.3.4 OTHER CASES

#### 6.3.4.1 Sewers

Test boring locations for sewers should be coordinated with roadway borings if possible. In addition, locate soil borings at points of maximum invert depths and to the extent possible, near manhole structure locations. If roadway borings are not performed as part of the investigation, borings must be spaced no greater than 500 ft along the proposed sewer line. Conduct auger drilling or split-spoon sampling to a depth that is at least 5 ft below the proposed maximum excavation elevation. For excavations that require shoring, split-spoon sampling should be conducted during advancement of the soil boring.

#### 6.3.4.2 Infiltration, Detention or Underground Storage Basins

For basins associated with the MDOT's Drainage Manual, conduct one auger boring (SPT borings with 2.5 ft sampling may be substituted) per one acre with a minimum of two borings per basin. The soil borings must be advanced to a minimum depth of 5 ft below the proposed deepest elevation of the basin.

If a sheet pile weir or shoring is proposed, then additional borings must be conducted for the design of this structure. The depth of the boring must extend to at least twice the height of the exposed wall face or a minimum of 20 ft.

A minimum of two field permeability tests per infiltration basin should be performed, with this number increasing for larger ponds. Detention basins do not require permeability testing as infiltration is ignored in design. Field permeability tests must be performed in accordance with ASTM D6391, ASTM D3385, and ASTM D8152. In lieu of the field permeability tests, laboratory hydraulic conductivity testing of the soil in accordance with ASTM D5084 may be substituted. Appropriate bulk or undisturbed samples of soil at the pond bottom must be collected to perform this laboratory testing.

For basins associated with the MDOT Stormwater Treatment Manual, conduct a minimum of one machine or hand boring at each basin. If infiltration data is needed, the geotechnical engineer can provide values based on the soil borings. The boring must be advanced to a minimum of 5 ft beyond the basin bottom. Sheet pile design borings associated with these basins must adhere to the guidance provided earlier in this subsection for the Drainage Manual requirements.

Sufficient testing should be conducted to verify whether the excavated material can be used for roadway construction. If rock is to be excavated from the pond, sufficient SPT borings and rock coring must be conducted to estimate the volume, rippability, and hardness of the rock to be removed.

#### 6.3.4.3 Wetland Mitigation

On certain projects, wetland mitigation consists of creating a wetland. These potential mitigation areas must be explored with soil borings and monitoring wells. Soil borings must be conducted in a grid pattern at a minimum of one boring per acre with a minimum of three total borings per site. Soil samples must also be collected for soil classification and testing for potential roadway use. In addition, a minimum of three monitoring wells must be installed per site.

#### 6.3.4.4 Trenchless Pipe Installation

Trenchless pipe installation commonly occurs within MDOT's right-of-way during the execution of construction projects. In many instances, pits are excavated to house necessary equipment and to facilitate installation of the drilling tools and pipe. In areas where this type of installation occurs, one soil boring must be located at each entry and exit point. Intermediate borings between these points should be considered on a case-by-case basis or if runs extend longer than 100 ft. Boring depths must extend to at least 10 ft below the bottom of pipe casing or borehole. When groundwater is encountered, consideration should be given to installing an observation well.

When utilities are installed using trenchless methods by local agencies or private entities, a permit is required by MDOT to work in the right-of-way. The geotechnical requirements for crossing the MDOT right-of-way can be found on Form 3702.



## SECTION 7 – LABORATORY TESTING

### 7.1 GENERAL

As with other phases of the geotechnical investigation, the laboratory testing should be intelligently planned in advance, but flexible enough to be modified based on test results. The purpose of the laboratory testing program is to validate visual soil classifications and assess the engineering properties of the soil and bedrock identified by the field exploration.

MDOT requires all laboratory testing for design conform to the requirements of the most current cited American Society for Testing and Materials International (ASTM), American Association of State Highway and Transportation Officials (AASHTO), or MTM standards. Users of the Manual must familiarize themselves with the requirements of these standards and issue laboratory reports that follow such protocols and include the required reporting information. All laboratory testing for design must fulfill the requirements of AASHTO R18 for qualifying testers and calibrating/verifications. Upon request of the Geotechnical Services Section (GSS), documentation must be provided verifying that the testing entity meets the requirements of AASHTO R18.

MDOT requires all laboratory testing for construction conform to the *Materials Quality Assurance Procedures Manual*.

### 7.2 SOIL

#### 7.2.1 GRAIN SIZE ANALYSIS

These tests must be performed on samples that were obtained for field classification verification on the major soil types encountered during the investigation. The number of tests should be limited to reasonably establish the stratification without duplication. A minor soil type, if not critical, may be given a visual classification instead of performing classification tests for reference.

This test is performed in two stages: sieve analysis for coarse-grained soils (sands, gravels) and hydrometer analysis for fine-grained soils (clay, silts). A grain size distribution curve with soil classification (ASTM D2487) must be provided as a part of the following tests.

##### 7.2.1.1 Sieve Analysis

Sieve analysis is used to determine the grain size distribution of soils. The soil is passed through a series of woven wires with square openings of decreasing sizes. The information obtained from the test allows the Geotechnical Engineer to classify the soil based on the percentage retained on the sieve.

This work must consist of determining the gradation of a sample in accordance with ASTM C136. Sieves used must consist of U.S. Standard Sieve sizes 3 in., 2 in., 1 in., and 3/8 in. and U.S. Standard Sieve Nos. 4, 10, 40, 100 and 200, with the soil decanted over the No. 200. Additional U.S. standard sieve sizes and numbers may be required.

#### 7.2.1.2 Hydrometer

The hydrometer analysis is used to determine the particle size distribution in a soil that is finer than a No. 200 sieve size (0.075 mm), which is the smallest standard size opening in the sieve analysis. The procedure is based on the sedimentation of soil grains in water. It is expressed by Stokes Law, which says the velocity of the soil sedimentation is based on the soil particles shape, size, weight, and viscosity of the water. Thus, the hydrometer analysis measures the change in specific gravity of a soil-water suspension as soil particles settle out over time.

The hydrometer analysis must be in accordance with ASTM D7928 and include a specific gravity determination performed in accordance with ASTM D854. If 20 percent or more passes the No. 200 sieve, a hydrometer analysis must be performed.

### 7.2.2 MOISTURE CONTENT

Moisture content is defined as the ratio of the weight of water in a sample to the weight of solids. The weight of the solids must be oven dried and is considered as weight of dry soil. Organic soils can have the water content determined but must be dried at a lower temperature for the weight of dry soil to prevent degradation of the organic matter.

This test must consist of the moisture content determination in accordance with ASTM D2216. Test representative samples of soil from each major stratum.

### 7.2.3 ATTERBERG LIMITS

Atterberg limits are different descriptions of the moisture content of fine-grained soils as it transitions between a solid to a liquid state. For classification purposes, the two primary Atterberg limits used are the plastic limit (PL) and the liquid limit (LL). The plastic index (PI) is also calculated for soil classification.

#### 7.2.3.1 Liquid Limit

The liquid limit is defined as the moisture content at which a soil transitions from a plastic state to a liquid state. Tests must be performed in accordance with ASTM D4318.

#### 7.2.3.2 Plastic Limit

The plastic limit is the moisture content at which a soil transitions from being in a semisolid state to a plastic state. Tests must be performed in accordance with ASTM D4318 .

### 7.2.3.3 Shrinkage Limit

The shrinkage limit (SL) is the water content corresponding to the behavior change from the semisolid to solid states of a silt or clay. It can also be defined as the water content at which any further reduction in water content will not result in a decrease in volume of the soil mass.

Shrinkage limit tests must be in accordance with ASTM D4943. This test should be performed only with prior approval from the GSS or region soils engineer.

### 7.2.4 SPECIFIC GRAVITY

The specific gravity of soil is defined as the ratio of the unit weight of a given material to the unit weight of water. For soils composed of particles smaller than the No. 4 sieve (4.75 mm), use the procedure described in ASTM D854. For particles larger than this sieve size, use the procedure described in ASTM C127.

The specific gravity of soil is needed to relate a weight of soil to its volume, and it is used in the computations of other laboratory tests such as the consolidation and hydrometer analysis.

### 7.2.5 UNIT WEIGHT

Unit weight is a direct determination of either the moist or total weight of the soil sample divided by the total cylindrical volume of the intact sample (for the total/moist unit weight), or the oven-dried weight divided by the total volume (for the dry unit weight). This test procedure is performed on soil with cohesive properties. When performing this test, take at least three height measurements (120 degrees apart) and a minimum of the three diameter measurements at the quarter points of the height.

### 7.2.6 STRENGTH TESTS

The strength of a soil is the maximum stress the soil structure can resist before failure. Soils generally derive their strength from friction between particles (expressed as the angle of internal friction,  $\phi$ ), or cohesion between particles (expressed as the cohesion,  $c$  in units of force/unit area), or both. These parameters are expressed in the form of total stress ( $c, \phi$ ) or effective stress ( $c', \phi'$ ). The total stress on any subsurface element is produced by the overburden pressure plus any applied loads. The effective stress equals the total stress minus the pore water pressure. The common methods of determining these parameters in the laboratory are discussed below.

#### 7.2.6.1 Unconfined Compression Test

The unconfined compression test is a quick method to determine the value of undrained shear strength for cohesive soils. The test involves a cohesive soil sample with no confining pressure and an axial load being applied to observe the axial strains corresponding to various stress levels. The stress at failure is referred to as the

unconfined compression strength. The undrained shear strength is taken as one-half the unconfined compressive strength.

The test must be conducted in accordance with ASTM D2166. These tests should be performed on undisturbed samples. A graph of the strain versus compressive stress must be included as part of the data report.

#### 7.2.6.2 Triaxial Compression Tests

The triaxial compression test is a more sophisticated testing procedure for determining the strength of a soil. The test involves a soil specimen subjected to an axial load until failure while also being subjected to confining pressure that approximates the in-situ stress conditions. These tests must be performed on undisturbed samples. Contact the GSS prior to proposing these tests. The three types of triaxial tests are described below.

*Unconsolidated-Undrained (UU)* - In unconsolidated-undrained tests, the specimen is not permitted to change its initial water content before or during shear. The results are total stress parameters. This test is used primarily in the calculation of immediate embankment stability during quick-loading conditions. Refer to ASTM D2850.

*Consolidated-Undrained (CU)* - The consolidated-undrained test is the most common type of triaxial test. This test allows the soil specimen to be consolidated under a confining pressure prior to shear. After the pore water pressure is dissipated, the drainage line will be closed, and the specimen will be subjected to shear.

CU tests must be conducted in accordance with ASTM D4767. A minimum of 3 tests on similar specimens with varying confining pressures must be made to determine the shear strength parameters. Pore pressure measurements must be taken during this test so that the effective stress parameters can also be derived.

*Consolidated-Drained (CD)* - The consolidated-drained test is conducted with similar methods as the consolidated-undrained test except that drainage is permitted during shear and the rate of shear is very slow. Thus, the buildup of excess pore pressure is prevented. Again, several tests on similar specimens must be conducted to determine the shear strength parameters. This test is used to determine parameters for calculating long-term stability of embankments.

#### 7.2.6.3 Housel Transverse Shear test

The transverse shearing resistance test is a direct measure of what may be called the static yield value, or that shear stress greater than which the soil will suffer progressive deformation. The force required to cause the complete failure of a sample in the transverse double shear of a soil cylinder 1.5 in<sup>2</sup> in cross-sectional area is measured.

Observations are made of the rate of shearing deformation for each of six or seven load elements applied at ten-minute intervals and the actual load at which progressive deformation occurs is determined by interpolation.

This test is unique to Michigan and has historical significance in calculating bearing and pile capacity. This work must be conducted in accordance with Michigan Test Method 401. For additional information on the details and use of this test, refer to the *Field Manual of Soil Engineering*, January 1970.

#### 7.2.6.4 Direct Shear

In this test, a thin soil sample is placed in a shear box consisting of two parallel blocks and a normal force is applied. One block remains fixed while the other block is moved parallel to it in a horizontal direction. The soil fails by shearing along a plane that is forced to be horizontal. A series of at least three tests with varying normal forces is required to define the shear strength parameters for a particular soil. This test is typically run as a consolidated-drained test on cohesionless materials. Tests must be performed in accordance with ASTM D3080.

#### 7.2.6.5 Miniature Vane Shear (Torvane)

The miniature vane shear test is performed to obtain undrained shear for plastic cohesive soils. These tests should be utilized in conjunction with a laboratory testing program. This test consists of a hand-held device that is pushed into the sample and a torque is measured. They can be performed in the lab or in the field, typically on the ends of Shelby tubes, split-barrel samples, test pits, and footing excavation. See ASTM D4648 for additional guidance on the miniature vane shear test.

#### 7.2.6.6 Pocket Penetrometer

The pocket penetrometer test is used to obtain the unconfined compressive strength of a soil sample, typically a split-spoon or Shelby tube sample. This test should be utilized in conjunction with a laboratory testing program. When performing this test, the hand-held device is slowly pushed into the soil sample to the designated depth marked on the device and the tip resistance is measured. This test can be performed in the lab or in the field, typically on the ends of Shelby tubes and split-barrel samples, test pits, and footing excavations. Common misreadings due to fast versus steady penetration and pushing against coarse sand or fine gravel particles can occur with this device. To prevent misreadings from occurring due to larger particles, the user should inspect the sample after testing to ensure no larger particles were encountered, thereby adversely affecting the reading.

### 7.2.7 ONE-DIMENSIONAL CONSOLIDATION TEST

The amount of settlement induced by placement of load bearing elements on the ground surface or the construction of earthen embankments will affect the performance of the

structure. Settlement occurs in the subsoils through a combination of the rearrangement of the individual particles and the squeezing out of water. The calculation of settlement involves many factors (including the magnitude of the load), the effect of the load at the depth at which compressible soils exist, the water table, and characteristics of the soil itself. Consolidation testing is performed to determine the nature of these characteristics.

The most often used method of consolidation testing is the one-dimensional test. The consolidation test unit consists of a consolidometer (oedometer) and a loading device. The soil sample is placed between two porous stones, which permit drainage. Load is applied incrementally and is typically held up to 24 hours. Typical load increments not including the seating load should be 0.125, 0.25, 0.5, 1, 2, 4, 8, and 16 tons per square foot (tsf). Unloading should be applied in 25 percent decrements of the maximum load. In some instances, the maximum load applied may need to extend to 32 tsf to obtain a minimum load of 4 times the preconsolidation pressure. The test measures the height of the specimen after each loading is applied. The results are plotted on a time versus deformation log scale plot. From this curve, two parameters can be derived: coefficient of consolidation ( $C_v$ ) and coefficient of secondary compression ( $C_\alpha$ ). These parameters are used to predict the rate of primary settlement and the amount of secondary consolidation.

After the time-deformation plots are obtained, the void ratio and the strain can be calculated. Two more plots can be presented: an  $e$ -log  $p$  curve that plots void ratio ( $e$ ) as a function of the log of pressure ( $p$ ) or an  $\epsilon$ -log  $p$  curve where  $\epsilon$  equals percent strain. The parameters necessary for settlement calculation can be derived from the  $e$ -log  $p$  curve and are: compression index ( $C_c$ ), recompression index ( $C_r$ ), preconsolidation pressure ( $P_c$ ), and initial void ratio ( $e_0$ ). Alternatively, the  $\epsilon$ -log  $p$  curve provides the compression index ( $C_{ec}$ ), the recompression index ( $C_{er}$ ), and the preconsolidation pressure ( $P_c$ ).

To evaluate the recompression parameters of the sample, an unload/reload cycle can be performed during the loading schedule. To better evaluate the recompression parameters for overconsolidated clays, the unload/reload cycle may be performed after the preconsolidation pressure has been defined. After the maximum loading has been reached, the loading is removed in appropriate decrements. Consolidation tests must be in accordance with ASTM D2435. In addition to the parameters noted earlier in this section, test reports must include test results from specific gravity, initial and final moisture contents, initial and final degrees of saturation, and unit weights. Individual data sheets for all time curves,  $e$ -log  $p$  curve, and the  $\epsilon$ -log  $p$  curve must also be provided as part of this test.

### 7.2.8 LOSS ON IGNITION TEST (LOI) – ORGANIC CONTENT

Organic soils demonstrate very poor engineering characteristics, most notably low strength and high compressibility. In the field, these soils can usually be identified by their dark color, musty odor, and low unit weight. The most used laboratory test for design purposes is the loss on

ignition test, which measures how much of a sample's mass burns off when placed in a muffle furnace. The results are presented as a percentage of the total sample mass. Tests must be performed in accordance with ASTM D2974.

### 7.2.9 PERMEABILITY TESTS

Permeability, also known as hydraulic conductivity, has the same units as velocity and is generally expressed in ft/min. Coefficient of permeability is dependent on void ratio, grain-size distribution, pore-size distribution, roughness of mineral particles, fluid viscosity, and degree of saturation. There are three standard laboratory test procedures for determining the coefficient of soil permeability: constant and falling head tests and flexible wall tests. Permeability can also be determined either directly or indirectly from a consolidation test.

#### 7.2.9.1 Constant Head

In the constant head test, water is introduced into a sample of soil and the difference of head between the inlet and outlet remains constant during the testing. After the flow of water becomes constant, water that is collected in a flask is measured in quantity over a time period. This test is more suitable for coarse-grained soils that have a higher coefficient of permeability. Tests must be conducted in accordance with ASTM D2434.

#### 7.2.9.2 Falling Head

The falling head test uses a similar procedure to the constant head test, but the head is not kept constant. The permeability is measured by the decrease in head over a specified time. Tests must be performed in accordance with ASTM D5856.

#### 7.2.9.3 Flexible Wall Permeability

For fine-grained soils, tests performed using a triaxial cell are generally preferred. In-situ conditions can be modeled by application of an appropriate confining pressure. The sample can be saturated using back pressuring techniques. Water is then allowed to flow through the sample and measurements are taken until steady-state conditions occur. Tests must be performed in accordance with ASTM D5084.

### 7.2.10 ENVIRONMENTAL CORROSION TESTS OR ELECTRO-CHEMICAL TESTS

These tests are performed to determine the corrosion classification of soil and water. A series of tests may include pH, resistivity, chloride content, and sulfate content testing. Based on the scope and soil conditions of the project, this testing may be appropriate. Testing can be done either in the laboratory or in the field. Sampling must be obtained in accordance with sampling procedures prepared by the Michigan Department of Environmental Quality.

#### 7.2.10.1 pH

The pH test is used to determine the acidity or alkalinity of the subsurface or surface water environments. Acidic or alkaline environments have the potential for being aggressive on structures (such as metallic culverts, anchors, steel strips, pipes, and steel

piles) placed within these environments. Soil samples collected during the normal course of a subsurface exploration may be used for pH testing. The pH of soils must be determined using ASTM G51. Surface water samples must have the pH determined using ASTM D1293.

#### 7.2.10.2 Chloride

Subsurface soils and surface water should be tested for chloride if the presence of salt laden or brackish water is suspected. Chloride testing for soils shall be determined using AASHTO T291 – Standard Method of Test for Determining Water-Soluble Chloride Ion Content in Soil. The chloride testing for the surface water shall be performed in accordance with ASTM D512.

#### 7.2.10.3 Sulfates

Subsurface soils and surface water may be tested for sulfate. Sulfate testing for soils must be determined using AASHTO T290. This test is commonly performed when considering subgrade chemical stabilization. The sulfate testing for surface water must be conducted in accordance with ASTM D516.

#### 7.2.10.4 Electrical Resistivity

Resistivity testing is used to determine the electric conduction potential of the subsurface environment. Where construction materials susceptible to corrosion are used in the existing subgrade, it is necessary to determine the corrosion potential of these soils. This test may be performed for structures with metallic components such as steel reinforcement, permanent steel sheet piling, soil anchors, soil nails, culverts, pipes, or piles. Resistivity must be determined using ASTM G57 (field method) or AASHTO T288 (laboratory method). The resistivity of surface water samples must be determined using ASTM D1125.

### 7.2.11 COMPACTION TEST

Compaction tests are used to determine the optimum water content and maximum dry density that can be achieved for a particular soil using a designated compactive effort. These tests are utilized in conjunction with certain laboratory tests (such as direct shear, California Bearing Ratio, and permeability) to establish a baseline when determining the density for testing remolded samples. For compaction testing on construction projects with earthwork, refer to the *MDOT Density Testing and Inspection Manual*.

#### 7.2.11.1 Standard Proctor

This test method uses a 5.5-pound rammer dropped from a height of 12 inches. The sample is compacted in three layers. Testing procedures must adhere to ASTM D698 (AASHTO T99).

#### 7.2.11.2 Modified Proctor

This test method uses a 10-pound rammer dropped from a height of 18 inches. The sample is compacted in five layers. Testing procedures must adhere to ASTM D1557 (AASHTO T180).

#### 7.2.11.3 Michigan Cone Test

This test method is intended for determining the dry density of granular soils under a standard method of compaction. Granular soils are defined here as soil material having less than 10 percent loss by washing and 100 percent passing the 2-inch sieve. This test is typically utilized for compaction verification of the fill during construction. For more information on this test, refer to the *MDOT Density Testing and Inspection Manual*.

### 7.2.12 CALIFORNIA BEARING RATIO

The California Bearing Ratio (CBR) is used to determine the strength of a soil under controlled moisture and density conditions. The test results are utilized to provide subgrade design values for pavement design. The test must be conducted in accordance with ASTM D1883 and requires approval by either the GSS or region soils engineer. A minimum of three identical soil samples are tested with varying relative density and moisture content as specified by the Geotechnical Engineer. CBR testing is encouraged on subgrade soils with high silt content (> 70 percent).

### 7.2.13 RESILIENT MODULUS TEST

This test is used to determine the dynamic elastic modulus of a base or subgrade soil under conditions that represent a reasonable simulation of the physical conditions and stress states of such materials under flexible pavements subjected to wheel loads. A prepared cylindrical sample is placed in a triaxial chamber and conditioned under static or dynamic stresses. A repeated axial stress is then applied at a fixed magnitude, duration, and frequency. The resilient modulus ( $M_r$ ) is calculated by dividing the deviator stress by the resilient axial strain. This value is used in the design and evaluation of pavement systems. Tests must be performed in accordance with AASHTO T307 and with approval of either the GSS or region soils engineer.

## 7.3 ROCK

Laboratory rock testing is performed to determine the strength and elastic properties of intact specimens and the potential for degradation and disintegration of the rock material.

Deformation and strength properties of intact rock core specimens aid in evaluating the larger-scale rock mass. Laboratory test results must be considered in conjunction with knowledge of the in-situ characteristics of the rock mass. This section covers common laboratory tests performed on intact rock core specimens.

### 7.3.1 UNIT WEIGHT

Unit weight is a direct determination of either the moist or total weight of the rock core sample divided by the total cylindrical volume of the intact sample (for the total/moist unit weight) or

the oven-dried weight divided by the total volume (for the dry unit weight). This measurement includes any voids or pore spaces in the sample and, therefore, can be a relative indicator of the strength of the core sample. Samples should be tested at the moisture content representative of field conditions, and samples should be preserved until time of testing. Moisture contents must be performed in accordance with ASTM D2216.

### 7.3.2 STRENGTH TESTING

#### 7.3.2.1 Unconfined (Uniaxial) Compression Tests

The purpose of this test is to determine the uniaxial compressive strength of rock. The uniaxial compression test is the most direct means of determining rock strength and must be conducted in accordance with ASTM D7012. Cylindrical rock specimens are tested in compression without lateral confinement. The test procedure is similar to the unconfined compression test for soil and concrete. The uniaxial test can also be conducted with confining pressure in a triaxial cell. Use of a confining pressure may be particularly valuable for softer rock.

#### 7.3.2.2 Point Load Tests

The purpose of the point load test is to estimate the unconfined compression strength of rock. The test is conducted by compressing a piece of rock between two points on cone-shaped platens until the rock specimen breaks in tension between these two points. Because the point load test provides an index value for the compressive strength, the Geotechnical Engineer should calibrate the results with a limited number of uniaxial compression tests. Tests should be conducted in accordance with ASTM D5731.

### 7.3.3 ELASTIC MODULI

The elastic modulus of an intact rock core specimen may also be obtained during the unconfined compression test. The strain for each loading step must be determined if the elastic modulus is measured. Because strains will be very small, the accuracy and resolution of the strain monitoring must be very high. By including lateral strain measurements during this test, it is possible to determine the Poisson's ratio of the test specimen.

## SECTION 8 – MATERIALS DESCRIPTION, CLASSIFICATION, AND LOGGING

### 8.1 GENERAL

During a field exploration, a log must be kept of the materials encountered. A field engineer, geologist, or driller usually keeps the field log. Details of the subsurface conditions encountered (including basic material descriptions, details of the equipment used, drill hole advancement and sampling methods, weather conditions, date and time of start and finish, boring locations and elevations, and other subsurface conditions observed (e.g., groundwater, heaving sands, drilling chatter) should be recorded. The guidelines provided in ASTM D5434 should be utilized to summarize the work when performing a subsurface exploration.

Material descriptions, classifications, and other information obtained during the subsurface explorations are heavily relied upon throughout the remainder of the investigation program and during the design and construction phases of a project. Therefore, it is necessary that the method of reporting this data is standardized between MDOT soil engineers, technicians, and consultants. Thus, MDOT has adopted the use of the following procedures presented in this chapter.

### 8.2 SOIL DESCRIPTION AND CLASSIFICATION

MDOT utilizes a modified Unified Soil Classification System (USCS) to describe soil in regard to soil type, color, relative density/consistency, etc. The description should match the requirements of the USCS as outlined in ASTM D2488 except as modified herein. This practice has particular value in grouping similar soil samples so that only a minimum number of laboratory tests need be run for positive soil classification. Where laboratory testing is conducted in accordance with ASTM D2487, the use of these soil descriptions should be recorded on the final boring log. With that said, it is common practice to leave out descriptors on the boring log such as lean, well graded, or poorly graded. A detailed soil description should include the following items, in this order:

Relative Density/Consistency → Color → Moisture → Soil Description (constituents) → Other pertinent information and descriptors.

Descriptors can be defined as particle angularity and shape, particle size, and structure. The following subsections briefly describe these items.

#### 8.2.1 RELATIVE DENSITY OR CONSISTENCY

Soil strength refers to the degree of load-carrying capacity and resistance to deformation that a particular soil may develop. For cohesionless granular soils (sand, gravel, and silt), the relative in-place density is a measure of strength. The in-place relative density for cohesionless soils can be estimated by the Standard Penetration Test (SPT - Blow counts) and by resistance to drilling equipment or “spiral” augers ([Figure 5](#)) as described in [Table 4](#). The use of spiral augers to

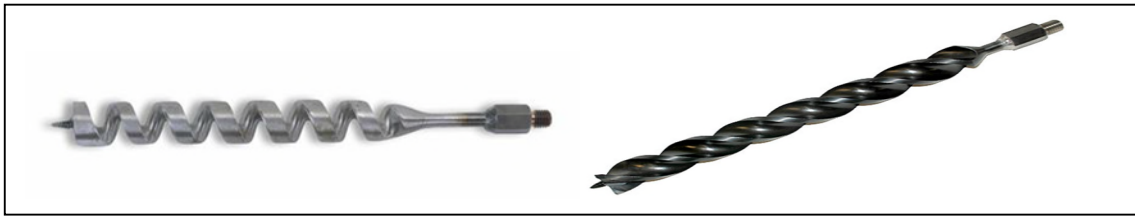

Figure 5: Typical Spiral Augers

identify relative consistency is not commonly used in typical field investigations but is occasionally used during footing subgrade inspections. For cohesive soils, “consistency” is a measure of cohesion or shear strength. The shear strength of clay soils can be estimated in the field using manual methods, the SPT, as noted in [Table 5](#), or a hand penetrometer. Table 5 is based on shear strength and not the estimated unconfined compressive strength as determined by a hand penetrometer. Note that, for clay soils, loss of moisture will result in increased strength; therefore, consistency of clay soils should be estimated at the natural moisture content.

Table 4: Relative Density for Cohesionless Soils

Descriptive Term	SPT – $N_{60}$ (blows/ft) <sup>1</sup>	Relative Density %	Resistance to Spiral Auger
Very Loose	≤ 4	0 – 20	The auger can be forced several inches into the soil without turning under the bodyweight of the technician.
Loose	5 – 10	>20 – 40	The auger can be turned into the soil for its full length without difficulty. It can be chugged up and down after penetrating about 1 ft so that it can be pushed down 1 inch into the soil.
Medium Dense	11 – 30	>40 – 70	The auger cannot be advanced beyond ±2.5 ft without great difficulty. Considerable effort by chugging required to advance further.
Dense	31 – 50	>70 – 85	The auger turns until tight at ±1 ft and cannot be advanced further.
Very Dense	> 50	>85 -100	The auger can be turned into the soil only to about the length of its spiral section.

<sup>1</sup>The above descriptor may be misleading in gravelly soils.

Table 5: Consistency for Cohesive Soils

Descriptive Term	SPT – $N_{60}$ (blows/ft)	Shear Strength – $s_u$ (psf)	Manual Index for Consistency
Very Soft	≤ 2	0 - 250	Extrudes between fingers when squeezed
Soft	3 – 4	> 250 - 500	Molded by light to moderate finger pressure
Medium Stiff	5 – 8	>500 – 1000	Molded by moderate to firm finger pressure

Descriptive Term	SPT – N <sub>60</sub> (blows/ft)	Shear Strength – s <sub>u</sub> (psf)	Manual Index for Consistency
Stiff	9 – 15	>1000 – 2000	Readily indented by thumb, difficult to penetrate
Very Stiff	16 - 30	>2000 – 4000	Readily indented by thumbnail
Hard	> 30	> 4000	Indented with difficulty by thumbnail

The soil consistency, when appropriate and available, should be added to the field classification at the very beginning, using the terminology described below. Examples: **Loose**, Brown, Moist, fine GRAVEL; **Medium Stiff**, Gray, Moist Sandy CLAY.

### 8.2.2 COLOR

Soil color is not in itself a specific engineering property but may be an indicator of other significant geologic processes that may be occurring within the soil mass. Color may also aid in the subsurface correlation of soil strata. Soil color should be determined in the field at its natural moisture content. Primary colors should be used (brown, gray, yellow, etc.). Soils with different shades or tints of basic colors are described by using two basic colors (e.g., gray-green, dark gray). When the soil is irregularly marked (spots, flecked, blotches, etc.), the term “mottled” can be applied (e.g., gray mottled brown). Examples are Brown, Gray, Black, Light Brown, Dark Gray.

### 8.2.3 MOISTURE CONDITION

The in-situ moisture condition should be determined using the visual-manual procedure. The moisture condition is defined using the following terms.

Table 6: Moisture Content Descriptions

Moisture Description	Criteria
Dry	Absence of moisture, dusty, dry to the touch
Moist	Damp but no visible water
Saturated	Visible free water

### 8.2.4 PARTICLE ANGULARITY AND SHAPE

Coarse-grained soils are described as angular, subangular, subrounded, or rounded. Gravel, cobbles, and boulders can be described as flat, elongated, or flat and elongated. Descriptions of fine-grained soils will not include a particle angularity or shape. For definitions and illustrations on these terms, refer to ASTM D2488.

### 8.2.5 CONSTITUENTS AND GRADATION

#### 8.2.5.1 Primary

The primary soil constituent is defined as the material fraction that has the greatest impact on the engineering behavior of the soil and represents the soil type found in the largest percentage. To determine the primary constituent, it must first be determined

whether the soil is “Fine-Grained” or “Coarse-Grained” or “Organic” as defined below. The field soil classification “word picture” will be built around the primary constituent as defined by the soil types described below. This term must be capitalized when listing the material description on the boring log.

**Coarse-Grained Soils:** More than 50 percent of the soil is retained on the No. 200 sieve. A good rule of thumb to determine if particles will be retained or pass the No. 200 sieve is if individual particles can be distinguished by the naked eye, then they will likely be retained. Also, the finest sand particles often can be identified by their sparkle or glassy quality.

- *Gravel* - Identified by particle size, gravel consists of rounded to angular particles of rock. Gravel size particles usually occur in varying combinations with other particle sizes. Gravel is subdivided into particle size ranges as follows: (Note that particles greater than 3 inches are cobbles or boulders, as defined in the Glossary of Terms.)
  - *Coarse* - Particles passing the 3-inch sieve and retained on the 3/4-inch sieve.
  - *Fine* - Gravel particles passing the 3/4-inch sieve and retained on the No. 4 sieve.

**Note:** The term "gravel" in this system denotes a particle size range and should not be confused with "gravel" used to describe a type of geologic deposit or a construction material.

- *Sand* - Identified by particle size, sand consists of rock particles, usually silicate (quartz) based, ranging between gravel and silt sizes. Sand has no cohesion or plasticity. Its particles are gritty grains that can easily be seen and felt and may be rounded (natural) or angular (usually manufactured). Sand is subdivided into particle size ranges as follows:
  - *Coarse* - Particles that will pass the No. 4 sieve and be retained on the No. 10 sieve.
  - *Medium* - Particles that will pass the No. 10 sieve and be retained on the No. 40 sieve.
  - *Fine* - Particles that will pass the No. 40 sieve and be retained on the No. 200 sieve.
  - *Well-Graded* - Indicates relatively equal percentages of fine, medium, and coarse fractions are present.

**Note:** The particle size of coarse-grained primary soils is important to the Geotechnical Engineer. Always indicate the particle size or size range immediately before the primary soil constituent.

Exception: The use of ‘Gravel’ alone will indicate both coarse and fine gravel are present. Examples: **fine and medium SAND; coarse GRAVEL.**

Include the particle shape (angular, partially angular, sub-rounded, or rounded) when appropriate, such as for aggregates, manufactured sands, or when it could significantly affect the engineering properties. Example: medium to coarse, **angular SAND**; **rounded GRAVEL**.

- *Cobbles and Boulders* - The coarse-grained soil classification as outlined in the Manual does not take into account the presence of cobbles and boulders within the soil mass. When cobbles and/or boulders are detected, either visually within a test pit or as indicated by drilling action/core recovery, they should be reported on the field logs after the main soil description. These two terms are defined in Section [8.2.8](#). The descriptor should be as follows:
  - *with cobbles* - when only cobbles are present
  - *with boulders* - when only boulders are present
  - *with cobbles and boulders* - when both cobbles and boulders are present

**Fine-Grained Soils:** More than 50 percent of the soil passes the No. 200 sieve.

- *Silt* - Identified by behavior and particle size, silt consists of material passing the No. 200 sieve that has low to no plasticity (no cohesion) and exhibits little or no strength when dried. Silt can typically be rolled into a ball or strand, but it will easily crack and crumble. To distinguish silt from clay, place material in the palm of one hand and with the other, make several vigorous blows on the heel of the hand holding the soil. If water appears on the surface, creating a glossy texture, then the primary constituent is silt.
- *Clay* - Identified by behavior and particle size, clay consists of material passing the No. 200 sieve and exhibits plasticity or cohesion (ability of particles to adhere to each other) within a wide range of moisture contents. Moist clay can be rolled into a thin 1/8-inch thread that will not crumble. Also, clay will exhibit strength increase with decreasing moisture content, retaining considerable strength when dry. Clay is often encountered in combination with other soil constituents such as silt and sand. If a soil exhibits plasticity, it contains clay. The amount of clay can be related to the degree of plasticity; the higher the clay content, the greater the plasticity.

**Note:** When applied to laboratory gradation tests, silt size is defined as that portion of the soil finer than the No. 200 sieve and coarser than the 0.002 mm. Clay size is that portion of soil finer than 0.002 mm. For field classification, the distinction will be strictly based upon cohesive/plasticity characteristics.

**Organic Soils:** Section [8.4](#) describes the classification process to be used for peat and common organic soils encountered in Michigan.

### 8.2.5.2 Secondary Soil Constituents

Secondary soil constituents represent one or more soil types other than the primary constituent that appear in the soil in significant percentages sufficient to readily affect the appearance or engineering behavior of the soil. To correlate the field classification with laboratory classification, this definition corresponds to the amounts of secondary soil constituents  $\geq 12$  percent for fine-grained and  $\geq 30$  percent for coarse-grained secondary soil constituents. The secondary soil constituents will be added to the field classification as an adjective preceding the primary constituent. Two or more secondary soil constituents should be listed in ascending order of importance. The use of Silty in Silty Clay as a secondary soil constituent should be determined based on the plasticity index criteria stated in ASTM D2487 versus the percentage of silt in the soil.

Examples: **Silty** fine SAND; **Peaty** MARL; **Gravelly, Clayey** SAND; **Sandy** SILTY CLAY; **Silty Clayey** SAND.

### 8.2.5.3 Tertiary

Tertiary soil constituents represent one or more soil types that are present in a soil in quantities sufficient to readily identify, but not in sufficient quantities to significantly affect the engineering behavior of the soil. The tertiary constituent will be added to the field classification with the phrase “with \_\_\_” at the end following the primary constituent and all other descriptors. This definition corresponds to approximately 5 to 12 percent for fine-grained and 15 to 29 percent for coarse-grained tertiary soil constituents.

Example: Dense, Gray, Saturated, Silty fine to coarse SAND **with Gravel and Peat**; Stiff, Brown, Moist CLAY **with Sand**.

Soil types that appear in the sample in percentages below tertiary levels need not be included in the field classification. However, the slight appearance of a soil type may be characteristic of a transition in soil constituents (more significant deposits nearby) or may be useful in identifying the soil during construction. These slight amounts can be included for descriptive purposes at the end of the field classification as “Trace of \_\_\_\_.” Example: Loose, Brown, Saturated, fine and medium SAND; **Trace of Silt** – Hard, Gray, Moist Sandy SILTY CLAY; **Trace of Gravel**.

## 8.2.6 ADDITIONAL DESCRIPTIVE TERMS

Additional descriptors should be added as needed to adequately describe the soil for the purpose required. These descriptors should typically be added to the field classification before the primary and secondary constituents, in ascending order of significance (exceptions noted below). Definitions for several descriptive terms can be found in the Glossary of Terms, Section [8.2.8](#). Other terms may be used as appropriate for descriptive purposes, but not for soil

constituents. Examples: Light Brown, Moist, **laminated** SILTY CLAY; Stiff, Brown, Moist, **blocky** CLAY.

Exceptions: Certain descriptive terms such as “Fill” may be more appropriate after the primary constituent or at the end of the field classification. Also, the description of distinct soils (inclusions) within a larger stratum should be added after the complete field classification of the predominant soil.

Examples of Exceptions: Brown, Moist Sandy CLAY **FILL** with coarse angular Gravel, brick and asphalt fragments or Loose, Brown, Moist SAND; Trace of organics and brick fragments (**FILL**) - Very Soft, Gray, Saturated MARL; **Occasional Lenses of Saturated fine Sand**.

#### 8.2.6.1 Unusual Odors

If during drilling activities, any unusual odors are encountered, they should be noted on the soil boring log/sheet. By noting these, the Geotechnical Engineer can evaluate if a potential design or construction issue related to the unusual odor exists.

#### 8.2.7 FIELD LOGGING

In addition to recording the soil description outlined in the previous subsections, the field investigation record should also include applicable items as outlined in ASTM D5434. Key items such as groundwater observations, artesian conditions, obstructions encountered, difficulties in drilling (caving, coring boulders, surging, or rise in sand inside casing or augers), loss of circulation, drilling mud, casing needed and why, sampler plugged, driving on rock, geotextile encountered, and drilling equipment utilized are beneficial information to the designer and contractor during the design and construction phase.

#### 8.2.8 GLOSSARY OF SOIL DESCRIPTION TERMS

- *Blocky* - Cohesive soil that can be broken down into small angular lumps that resist further breakdown.
- *Boulder* - A rock fragment, usually rounded by weathering or abrasion, with average dimension of 12 inches or more.
- *Calcareous* - Soil containing calcium carbonate either from limestone deposits or shells. The carbonate will react (fizz) with weak hydrochloric acid.
- *Cemented* - The adherence or bonding of coarse soil grains due to presence of a cementitious material. May be *weak* (readily fragmented), *firm* (appreciable strength), or *indurated* (very hard, water will not soften, rocklike).
- *Cobble* - A rock fragment, usually rounded or partially angular, with an average dimension of 3 to 12 inches.

- *Fat Clay* - Fine-grained soil with very high plasticity and dry strength. Usually has a sticky or greasy texture due to very high affinity for water. Remains plastic at very high water contents (Liquid Limit >50).
- *Fill* - Man-made deposits of natural soils and/or waste materials. Document the components carefully since presence and depth of fill are important engineering considerations.
- *Fissured* - The soil breaks along definite planes of weakness with little resistance to fracturing.
- *Frequent* - Occurring more than one per 1 ft thickness.
- *Friable* - A soil that is easily crumbled or pulverized into smaller, non-uniform fragments or clumps.
- *Laminated* - Alternating horizontal strata of different material or color, usually in increments of ¼ inch or less.
- *Layer* - Horizontal inclusion of soil greater than 4 inches thick but less than 12 inches.
- *Lens* - Inclusion of a small pocket of a soil between 3/8 inch and 4 inches thick, often with tapered edges.
- *Mottled* - Irregularly marked soil, usually clay, with spots of different colors.
- *Muck* - See Section [8.4](#).
- *Occasional* - Occurring once or less per 1 ft thickness.
- *Organic* - Indicates the presence of material that originated from living organisms, usually vegetative, undergoing some stage of decay. May range from microscopic size matter to fibers, stems, leaves, wood pieces, shells, etc. Usually dark brown or black in color and accompanied by a distinct odor.
- *Parting* - A very thin soil inclusion of up to 3/8-inch thickness.
- *Stratum* – Horizontal inclusion of soil greater than 12 inches thick.
- *Trace* - Indicates appearance of a slight amount of a soil type, which may be included in the classification for descriptive or identification purposes only. The use of this term is described in the Tertiary subsection above.
- *Varved* - The paired arrangement of laminations in glacial sediments that reflect seasonal changes during deposition; fine sand and silt are deposited in the glacial lake during summer and finer particles are usually deposited in thinner laminations in winter.

### 8.3 ROCK DESCRIPTION AND CLASSIFICATION

There are numerous rock classification systems, but none of these is universally used. This section provides a composite of those classification systems that incorporates the significant descriptive terminology relevant to MDOT geotechnical design and construction.

Rocks are classified into three major divisions: igneous, sedimentary, and metamorphic. All three rock types are found in the State of Michigan.

Table 7: Rock Type Classifications

Rock Type	Definition
Igneous	Derived from molten material
Sedimentary	Derived from settling, depositional, or precipitation processes
Metamorphic	Derived from pre-existing rocks due to heat, fluids, and/or pressure

A detailed rock description provided on the boring log should include the following applicable items.

- Color → Degree of Weathering → Rock Type → Grain size → Strength → Other pertinent descriptive terms and information.

Descriptors can be defined as texture, structure, mineral composition, rock hardness, and discontinuities. The rock description determination and logging must include identification of discontinuities and fractures for classification of the rock mass strength. However, the detail of the rock description provided for a particular rock type should be dictated by the complexity and objectives of the project. For instance, projects that involve rock stability or require excavation into the underlying rock (micropiles, drilled shafts) warrants more detail when developing the rock description. The Soil Boring Data Sheet provided in [Figure 9](#) gives an example of standard rock descriptions. Additional descriptors, if presented, must be relevant to the design of the project. The following subsections briefly describe the rock descriptors.

#### 8.3.1 COLOR

The color should be determined in the field from fresh samples directly after removal from the core barrel. Primary colors should be used (brown, gray, yellow, etc.). Rocks with different shades or tints of basic colors are described by using two basic colors (e.g., gray-green, dark gray). Examples are Brown, Gray, Black, Light Brown, Dark Gray.

#### 8.3.2 WEATHERING

The degree of weathering must be described as part of the rock classification. The degree of weather is defined as follows.

Table 8: Rock Weathering Terms

Description	Definition
Fresh	Rock shows no sign of weathering, loss of strength, or other effects of weathering such as slight discoloration on major discontinuity surfaces
Slightly Weathered	Rock is slightly discolored, but not noticeably lower in strength than fresh rock
Moderately Weathered	Rock is discolored and noticeably weakened, but less than half is decomposed; a minimum of 2-inch diameter sample can be broken readily by hand across the rock fabric
Highly Weathered	More than half of the rock is decomposed; rock is weathered so that a minimum 2-inch diameter sample can be broken readily by hand across the rock fabric
Completely Weathered	Original minerals or rock have been almost entirely decomposed to secondary minerals even though the original fabric may be intact; material can be granulated by hand
Residual Soil	Original minerals of rock have been entirely decomposed to secondary minerals, and original rock fabric is not apparent; material can be easily broke by hand

### 8.3.3 CONSTITUENTS

The principal constituent is the rock type constituting the major portion of the stratum being investigated. The rock type provided on the Soil Boring Data Sheet must be identified by either a professional geologist or a qualified Geotechnical Engineer. Rock descriptions should use technically correct geologic terms, although accepted local terminology may be used provided the terminology helps describe distinctive characteristics. Some examples of rock types are limestone, shale, slate, dolomite, basalt, and sandstone.

### 8.3.4 STRENGTH

[Table 9](#) presents guidelines for common qualitative assessment of strength while mapping or during primary logging of rock cores at the site by using point load test correlations or a geologic hammer and pocketknife. The field estimates should be confirmed where appropriate by comparisons with selected laboratory tests, such as the point load test or uniaxial compression test as discussed in Section [7.3.2](#). Provide qualitative descriptions of factors that might affect strength such as weak layers and any seams for which strength tests are not representative.

Table 9: Strength Terms

Description	Definition	Approximate Uniaxial Compressive Strength (psi)
Extremely Weak Rock	Can be indented by thumbnail	35 - 150
Very Weak Rock	Can be peeled by pocket knife	150 - 725
Weak Rock	Can be peeled with difficulty by pocketknife	725 – 3,500
Medium Strong Rock	Can be indented 3/16 inch with sharp end of pick	3,500 – 7,000
Strong Rock	Requires one blow of geologist's hammer to fracture	7,000 – 15,000
Very Strong Rock	Requires many blows of geologist's hammer to fracture	15,000 – 36,000
Extremely Strong Rock	Can only be chipped with blows by geologist's hammer	> 36,000

### 8.3.5 GRAIN SIZE

The grain size description should be classified according to the terms presented in [Table 10](#). This description is typically utilized for sedimentary rocks. The grain size descriptions are consistent with those used in the USCS for soil particles.

Table 10: Terms to Describe Rock Grain Size

Description	Grain Size (mm)	Characterization of Individual Grains
Very coarse grained	>#4 (>4.75)	Grains are greater than popcorn kernels
Coarse grained	#10 to #4 (2.00-4.75)	Individual grains can easily be distinguished by eye
Medium grained	#40 to #10 (0.425 – 2.00)	Individual grains distinguished by eye
Fine grained	#200 to #40 (0.075 - 0.425)	Individual grains distinguished by eye with difficulty
Very fine grained	< #200 (0.075)	Cannot be distinguished by unaided eye

### 8.3.6 DISCONTINUITIES

Discontinuity is the general term for any mechanical break in a rock mass that has zero or low tensile strength. It is the collective term for most types of joints, weak bedding planes, weak schistosity planes, weakness zones, and faults. When determining the Rock Mass Rating (RMR) on the core run, the Geotechnical Engineer must carefully record the type, shape, width, and surface roughness of the discontinuity. In addition, the fill material within the discontinuity should be logged. It is best practice to record the discontinuities in the field immediately after the core has been removed from the barrel. For additional information on determining these parameters, refer to NHI Course No. 132012 and GEC No. 5.

### 8.3.7 ROCK FRACTURE DESCRIPTION

Naturally occurring fractures are described by using the same terminology (surface roughness, shape, and aperture width) that is used for discontinuities. The number of naturally occurring fractures observed in each 1 ft of core should be recorded as the fracture frequency. “Good” practice is to have the field geotechnical engineer or geologist log the fractures per foot while the core is still in the tube liner or immediately after it has been transferred to the core tray or box. Mechanical breaks, thought to have occurred during drilling or handling, are not counted.

In certain cases, as determined useful by the Geotechnical Engineer, the degree of fracturing is added as a descriptor to the rock description. The terms in [Table 11](#) should be used to describe the degree of fracturing observed in the rock core.

Table 11: Terms to Describe Degree of Rock Fractures

Description	Spacing
Unfractured	> 10 ft
Intact	3 ft to 10 ft
Slightly Fractured	1 ft to 3 ft
Moderately Fractured	4 inches to 12 inches
Fractured	2 inches to 4 inches
Highly Fractured	< 2 inches

### 8.3.8 RECOVERY AND ROCK QUALITY DESIGNATION (RQD)

Core recovery and RQD should be logged while the core is in as close to its original condition as possible. Ideally, this information is determined while the core is still in the tube liner or split tube or immediately after it has been transferred to the core box. Mechanical breaks, such as caused by handling or drilling, should be noted as such and not included in the RQD calculations. The core recovery and RQD must be reported with the rock description on the boring log. These values should be calculated in accordance with guidelines presented in ASTM D2113 and FHWA NHI-01-031.

### 8.3.9 ROCK MASS RATING (RMR)

The information obtained in the previous sections is used to develop the RMR. The RMR is used as a basis for design of transportation facilities constructed in, on, or of rock. It should be determined using the guidelines presented in Section 10 of the *AASHTO LRFD Bridge Design Specifications*. Obtaining this value on all projects where rock coring is conducted is not always necessary and should be determined by the Geotechnical Engineer on a case-by-case basis.

## 8.4 CLASSIFICATION OF SWAMP DEPOSITS

Through swamp areas, it has become evident that embankments must be constructed so that they extend to a stable foundation. The manner in which this will be accomplished and the problems that will be encountered depend largely on the type and depth of materials that exist

in the swamp. Because of the importance of the type of the swamp materials, a comprehensive classification taken largely from the works of Dr. Alfred Dachnowski-Stokes is given in the following paragraphs.

The presence of peat or muck is generally easily discernible by surface appearance and vegetation. An adequate conception of peat deposits can be obtained only from information on an entire vertical section or profile of a peat area down to the underlying mineral soil. It is important to bear in mind that peat deposits, under natural conditions, consist of different layers of peat superimposed upon one another. These layers differ markedly in composition and show considerable range in physical properties, organic constituents, and reaction to the activity of micro-organisms and growing plants.

Peat deposits represent different stages in a process of development, which in many instances has continued since the close of the ice age and is still in progress. The deposits vary in size and depth, in the number, thickness and composition of layers, and in such characteristics as color, reaction and elevation of water level.

The purpose of the following classification is to present the properties and characteristics of the different types of swamp deposits that determine their behavior when subjected to standard methods of construction. The relationship between the several kinds of swamp material and the units of natural vegetation that have given rise to them in a succession of stages will become evident from the following diagrams and descriptions.

The various methods of swamp treatment are discussed in detail in the *Standard Specifications for Construction* and [Standard Plan R-103 series](#). The Geotechnical Engineer should become thoroughly acquainted with the standard methods of treatment for average swamp conditions and should be so informed as to recognize unusual conditions that require special treatment.

#### 8.4.1 SEDIMENTARY PEAT

In any shallow lake or pond, the history of a peat deposit begins with a stage of vegetation associated with the open water. It consists of microscopic organisms, submerged plants, pond weeds, water lilies, and similar forms of plant life. The yearly addition of decaying bodies of such organisms in depressions and basins accumulates to form a soft, oozy, structureless peat. It contains plant remains that are recognizable and material that has lost all traces of its origin and has become changed into an amorphous residue.

Sedimentary peat is fine-textured material, which is often gelatinous when wet but hard when dry. In some localities, it occurs as a dense, impervious organic sediment; in other places, it contains bits of tissue from roots and leaves, a variety of seeds, wind-blown pollen, quantities of shells from mollusks, and diatoms that have siliceous skeletons, or sand, silt, and clay. The color of sedimentary peat ranges from brown to olive green.

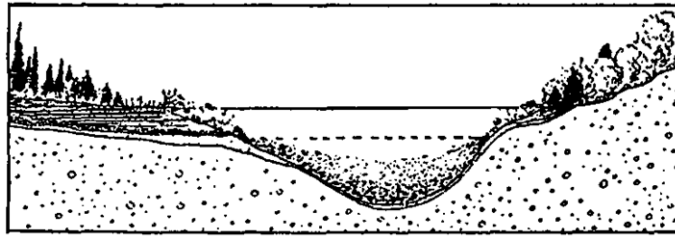

Figure 6: The Formation of Sedimentary Peat

#### 8.4.2 SEMI-ORGANIC SEDIMENTARY DEPOSITS

These are soft sedimentary deposits of silt, mixed with sand, clay and organic material, occurring in deep glacial drainage ways. They have many of the objectionable characteristics of sedimentary peat but generally are more stable. The material is generally identified as 'soft sediments' in boring logs or swamp soundings. In the USCS classification system, this may be identified or described as "ORGANIC SILT." The organic content varies between 4 and 10 percent by dry weight. The moisture content commonly has a range from 50 to 70 percent by dry weight. Its dry density generally ranges from 50 to 70 pounds per cubic foot (pcf). The transverse yield shear value ranges from 75 to 200 psf. In particle size distribution, the material generally averages more than 50 percent in silt size with the balance split between the sand and clay-colloid sizes. Because of a high percentage of mineral silt and sand, soft sediments often lend themselves better to treatment by consolidation rather than displacement. In addition, the classification of this material should adhere to the guidelines provided in ASTM D2487.

The physical properties of soft sediments are given above for the purpose of distinguishing this material from true peat because it is often incorrectly identified as sedimentary peat. Material classified as peat contains 20 to 30 percent or more organic matter. True peats have very low dry weights, commonly 25 pcf or less and sometimes as low as 5 pcf. The moisture content of peats commonly ranges from 100 to 500 percent and often well exceeds 1000 percent. The shear value for peat normally is less than 50 psf.

#### 8.4.3 FIBROUS PEAT

The second stage in the development of a peat deposit is generally associated with the encroachment of marsh vegetation upon the lake or pond in which the free water surface is disappearing by the filling process of aquatic plants. In this case, the dominant vegetation consists either of sedges (such as wire grass, saw grass, tule, rushes with cattail) or of reeds, canes, and reedlike grasses. These plants have a root growth that in time builds up to a firm, coarse to felty fibrous and porous peat layer of an interwoven network of underground stems and roots.

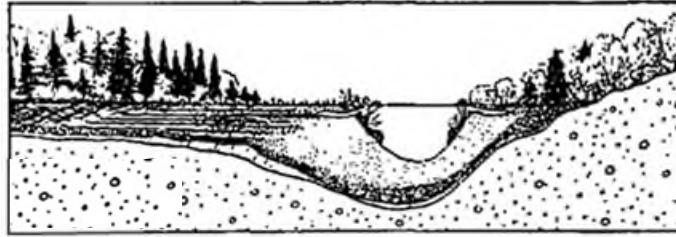

Figure 7: The Formation of Fibrous Peat

#### 8.4.4 WOODY PEAT

The final stage of native vegetation that establishes itself upon a layer of reed or sedge peat under natural conditions is a swamp forest of conifers together with deciduous trees. Under these conditions, the principal source of organic matter is an accumulation of fallen logs, branches, and roots varying in size and degree of decomposition. Additional marked effects of the influence of a swamp forest are indicated by the litter from leaves and needles, by a considerable contribution of bits of twigs, bark, cones and fruiting bodies, and by a considerable amount of crumbly, granular residue (duff or leaf mold) matted together by a meshwork of roots and the mycelium of fungi.

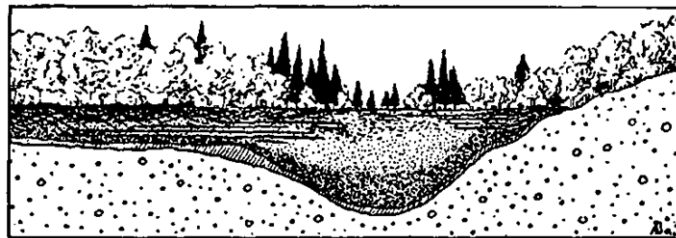

Figure 8: The Formation of Woody Peat

#### 8.4.5 MOSS PEAT

Moss peat differs markedly in character and composition from the kinds of peat previously described. It is formed predominately by the small stems and leaves of sphagnum mosses. The native surface vegetation is made up largely of various species of sphagnum and a scattered growth of sedges and small ericaceous shrubs (principally leatherleaf, Labrador tea, laurel, blueberries) together with scrubby, dwarfed black spruces and tamarack. There is not much timber growth owing to the very low amount of soluble mineral and organic constituents in the water retained by the mosses. Moss peat may be classified as fibrous peat.

#### 8.4.6 MUCK

Although the terms peat and muck are often used synonymously, the two are distinguished based on the degree of decomposition. Muck is black, structureless ooze containing no identifiable plant remains. It represents the advanced state of decomposition of plant remains. Muck generally comprises the well decomposed surface material of swamps and wet depressions.

#### 8.4.7 RELATIONSHIP BETWEEN COLOR AND DEGREE OF DECOMPOSITION

Color is one of the important aids in the recognition of different grades of peat. There is generally a progressive darkening in color as peat material decomposes to muck.

To express the degree of decomposition that has taken place, it has been found practical in highway work to employ an arbitrary scale of three divisions. These represent more or less definite values to indicate grades of slightly decomposed peat, partly decomposed peat and well decomposed peat or muck.

Partially decomposed grades of peat are usually brown. Very dark brown and black colors serve as a general basis for estimating grades of well decomposed peat or muck. They are the result of active oxidation and of a high proportion of residual material contributed chiefly by the activity of micro-organisms.

#### 8.4.8 MARL AND VERY SOFT CLAY

Marl and very soft clay are sometimes encountered in association with peat. Marl consists of fresh water deposits of calcium carbonate with small and varying percentages of peat, clay, and fine sand. In color, it ranges from dull gray to almost white. The texture varies with the mode of origin and ranges from very fine textured precipitates to the coarser textured deposits of shells from mollusks, nodules, and cylinders from stonewort. Marl has a very definite chalky feel and very little plasticity when tested between the thumb and finger. It may occur anywhere in the peat profile below the surface peat, with the purer deposits usually found in the shallow portions of the swamp. Very soft clay, when present, always occurs at the bottom of the swamp. It differs from underlying soil material because it is of more recent origin and, therefore, unconsolidated. It is often more fluid than the overlying sedimentary peat and feels very sticky and very smooth when tested between the thumb and finger. When inspected, very soft clay has a consistency similar to toothpaste.

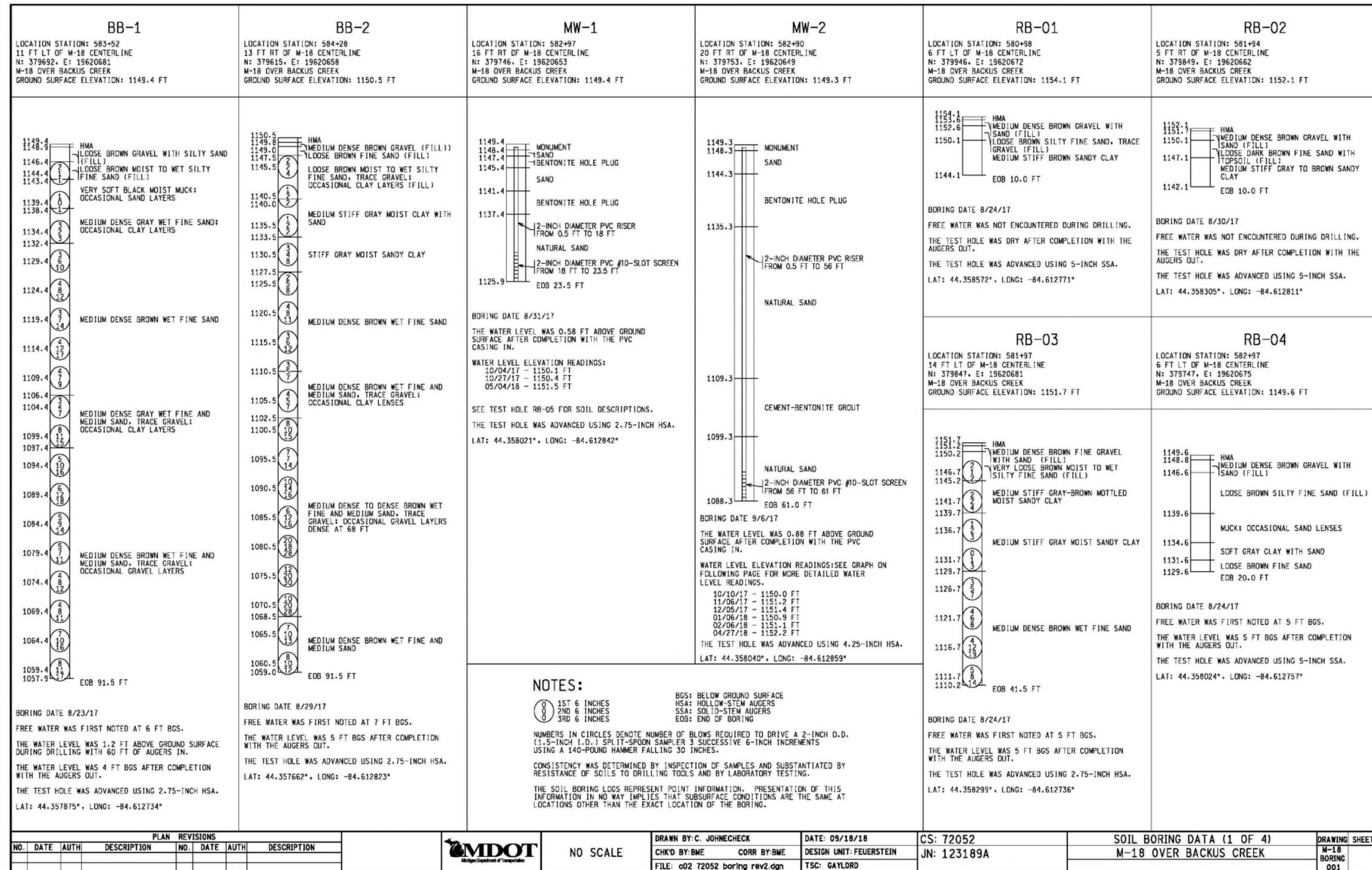

Figure 9: Example 1 Soil Boring Data Sheet

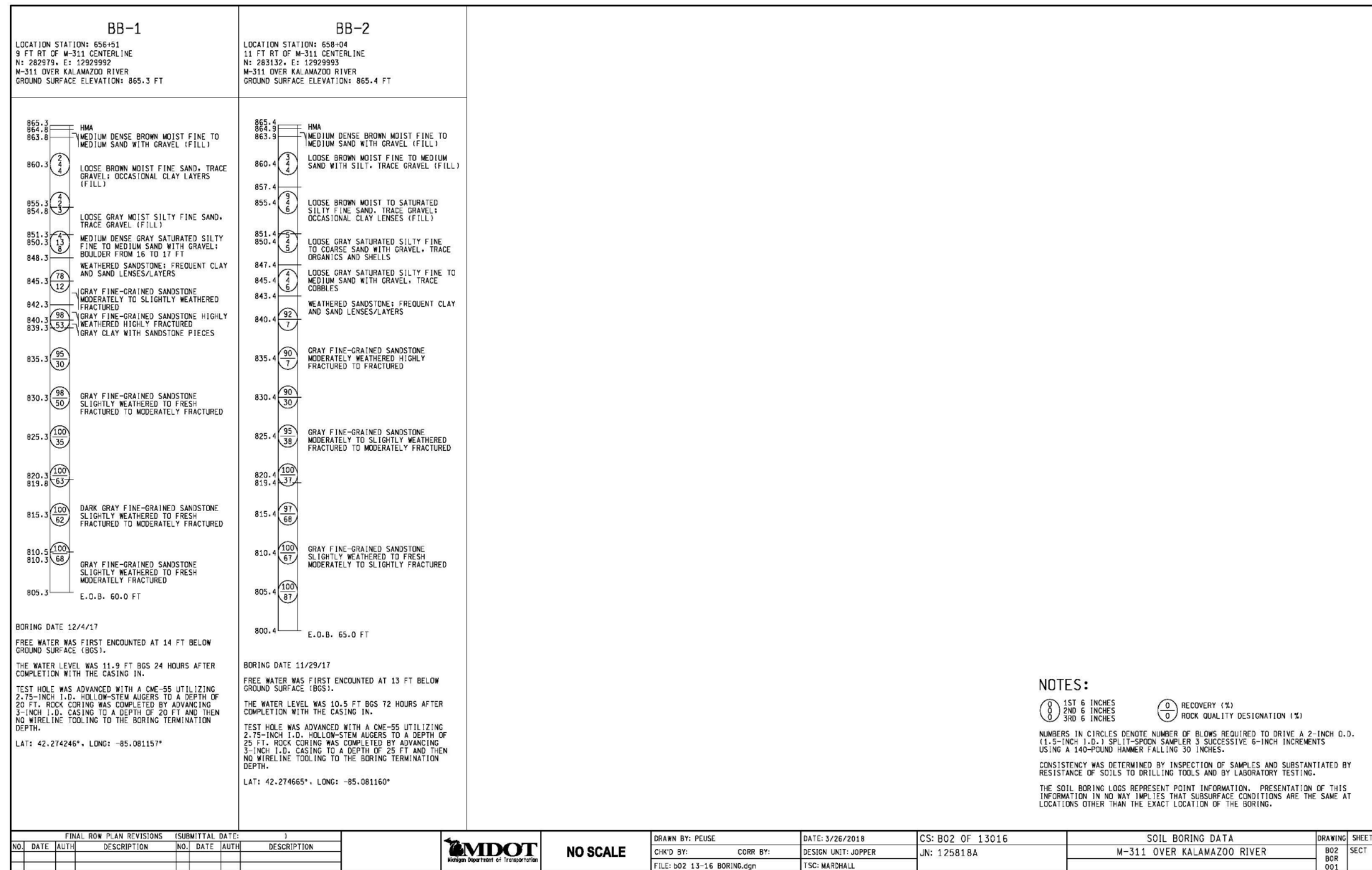

Figure 10: Example 2 Soil Boring Data Sheet

## SECTION 9 – GEOTECHNICAL ANALYSIS

### 9.1 GENERAL

This section presents MDOT’s geotechnical design guidelines. This includes the approach to the geotechnical investigations of the project and the correlations that link the field and laboratory work that precedes this section to the engineering analysis that is described here. Once all exploration and testing have been completed, the Geotechnical Engineer must organize and analyze all existing data and provide recommendations. The geotechnical engineer-of-record must develop a design approach that reflects both the requirements of the Manual, as well as generally accepted industry practice.

Accordingly, the geotechnical engineering consists of interpreting field data, developing geologic profiles, selecting foundation types, performing analyses, developing designs, plans and specifications, construction monitoring, maintenance, etc. This is accomplished by knowing applicability and limitations of the geotechnical design methodologies and assessing the uncertainties associated with soil properties and the resulting impact on structural performance. The Geotechnical Engineer is required to evaluate the design or analysis and decide if it is “reasonable” and if it will meet the performance expectations that have been established. Reasonableness is a subjective term that depends on the engineer’s experience, both in design and construction. If the solution does not appear reasonable, the engineer should make the appropriate changes to develop a reasonable solution. In addition, the Geotechnical Engineer should document why the first solution was not reasonable and why the second solution is reasonable. This documentation is an important part of the development of the design approach. If the solution appears reasonable, then design should proceed to the economics of geotechnical engineering.

The economics of geotechnical engineering assesses the effectiveness of the solution from a cost perspective. Sometimes designers and geotechnical engineers get caught up in the science and art of geotechnical engineering and do not evaluate other non-geotechnical solutions that may be cost effective both in design and construction. For example, alternate alignments should be explored to avoid poor soils or on existing unstable slopes, decreasing vertical alignment to reduce embankment loads, placing alternate designs on the plans to facilitate competitive bidding. The science, art, and economics are not sequential facets of geotechnical engineering but are very often intermixed throughout the design process. As a result, it is crucial that communication between the interdisciplinary groups involved in the design occur throughout this process.

#### 9.1.1 GEOTECHNICAL ENGINEERING QUALITY ASSURANCE

A formal internal geotechnical engineering quality assurance plan should be established for all phases of the geotechnical engineering process. The first-line geotechnical engineer is expected to perform analyses with due diligence and a self-prescribed set of checks and balances. The

geotechnical quality control plan should include milestones in the project development where analysis, recommendations, etc. are reviewed by at least one other geotechnical engineer of equal experience or higher seniority. Documentation that the quality assurance process has been followed and must be evident upon review of geotechnical calculations, reports, etc. (e.g., signatures, initials, other notations). All engineering work must be performed under the direct supervision of a professional engineer licensed by the State of Michigan.

## 9.2 FINAL SELECTION OF DESIGN VALUES

After the field investigation and laboratory testing is completed, the geotechnical designer must review the quality and consistency of the data and should determine if the results are consistent with expectations. Once the lab and field data have been collected, the process of developing a subsurface profile and selecting final material properties begins. At this stage, the geotechnical designer generally has several sources of data consisting of that obtained in the field, laboratory test results and correlations from index testing. In addition, the geotechnical designer may have experience based on other projects in the area or in similar soil/rock conditions. Therefore, if the results are not consistent with each other or previous experience, the reasons for the differences should be evaluated, poor data eliminated or marginalized (based on evaluation) and trends in data identified. At this stage, it may be necessary to conduct additional tests to try and resolve discrepancies.

Where reliability data was used to establish load and resistance factors, the factors were developed assuming mean values for the design properties used. On occasion, design values that are more conservative than the mean may still be appropriate, especially if there is an unusual amount of uncertainty in the assessment of the design properties due, for example, to highly variable site conditions, lack of high-quality data to assess property values, or widely divergent property values from the different methods used to assess properties within a given geologic unit.

### 9.2.1 DEVELOPMENT OF A SUBSURFACE PROFILE

To better understand the site and aid in determining final design values, the Geotechnical Engineer should develop a subsurface profile that “paints a picture” of the stratigraphy within the project limits. Ultimately, a working model is developed that depicts major subsurface layers exhibiting distinct engineering characteristics. While this is useful to evaluate and interpret the data gathered and ultimately provide design and construction recommendations, this is considered interpretive data and the profile should not be included as a contract document.

The following steps outline the creation of the subsurface profile:

1. Complete the field and lab work and incorporate the data into a soil boring log sheet or individual boring logs.
2. Create a cross-section(s) by plotting borings at their respective elevations and positions horizontal to one another with appropriate scales. Understanding the geologic

deposition/history can be very useful, especially at river crossings where the river may have been relocated or may have meandered over time. Caution should be exercised when attempting to connect with soil layers in adjacent borings because the geologic stratigraphy may not be consistently thick or consistently present. It has been the experience of MDOT that soil profiles at river crossings can be considerably different, particularly at relatively shallow depths, from one side to the other.

If appropriate, two or more cross-sections, longitudinal and transverse to the structure/roadway centerline can be developed when a site has large extents or varying conditions. For instance, wider bridge structures may warrant a cross-section longitudinally along the centerline of the entire bridge and then transversely at each substructure if variations are seen in the borings between each of the substructure units. Multiple cross-sections may also be useful when conducting a global stability analysis at a bridge approach or in a critical fill/cut section.

3. Analyze the profile(s) to see how it compares with the expected results and knowledge of geologic history. Make modifications to the profile as necessary.

### 9.2.2 SOIL STRENGTH DETERMINATION

The selection of soil shear strength for design should consider, at a minimum, the following:

- The rate of construction loading relative to the hydraulic conductivity of the soil (i.e., drained or undrained strengths);
- The effect of applied load direction from the structure on the measured shear strengths during testing;
- The effect of expected levels of deformation for the geotechnical structure or soil mass; and
- The effect of the construction sequence on the loading and drainage of the soil profile.

In general, where loading is rapid enough and/or the hydraulic conductivity of the soil is low enough such that excess pore pressure induced by the proposed loading will not dissipate, undrained (total) stress parameters should be used. Where loading will be slow enough and/or the hydraulic conductivity of the soil is great enough such that excess pore pressures induced by the applied load dissipate as the load is applied, drained (effective) soil parameters should be used. Drained (effective) soil parameters should also be used to evaluate long-term conditions where excess pore pressures have been allowed to dissipate or where the designer has explicit knowledge of the expected magnitude and distribution of the excess pore pressure.

### 9.2.3 DRAINED STRENGTH OF GRANULAR SOILS

The drained friction angle of granular deposits should be evaluated by empirical correlation to the results of SPT testing, other relevant in-situ tests, and/or laboratory shear strength tests on undisturbed samples (if feasible) or reconstituted disturbed samples. If reconstituted samples

are used in this endeavor, the samples should be compacted to the same relative density estimated from the available in-situ data. The following sections provide guidance in correlating the SPT test to the drained angle of friction.

### 9.2.3.1 Standard Penetration Test Corrections

Many correlations exist that relate the corrected N-values to relative density ( $D_r$ ), peak effective angle of internal friction, undrained shear strength, and other parameters; therefore, it is incumbent upon the designer to understand the correlations being used and the requirements of the correlations for corrected N-values. Design methods are available for using N-values directly in the design of driven piles, embankments, spread footings, drilled shafts, etc. These methods and correlations were developed based on the standard of practice, which corresponds to an average hammer efficiency ( $E_f$ ) of 60 percent. When using these correlations or design methods in the analysis, it is the onus of the Geotechnical Engineer to use appropriate corrected N-values. Standard designations used for corrected N-values are  $N_{60}$  and  $N_{160}$ . Corrections to obtain these values are discussed in greater detail in the following sections. It should be noted that these are not the only corrections that can be made to the field SPT values, but are more commonly used in geotechnical design, and the Geotechnical Engineer must determine the applicable correction values for each specific project. More guidance on the use of correction factors can be found in Federal Highway Administration (FHWA) *Subsurface Investigations – Geotechnical Site Characterization (NHI-01-031)*, *FHWA Soils and Foundations Workshop (NHI-00-045)* publication, and the *FHWA Evaluation of Soil and Rock Properties (FHWA-IF-02-034)* publication.

#### 9.2.3.1.1 Correction for Hammer Efficiency

In standard practice, a variety of hammer systems are used to perform the standard penetration test. These systems can have varying levels of performance and should be corrected when using correlations or design methods that were developed based on a  $N_{60}$  value. The correction equation is summarized below.

$$N_{60} = N_{\text{field}} * E_f / 60$$

$N_{\text{field}}$  = the N-value measured in the field during the test.

$E_f$  = the efficiency of the hammer system used to conduct the test. This is determined based on calibration of the SPT hammer as described in [Section 5.8.1](#).

#### 9.2.3.1.2 Correction for Overburden Pressure

Since N-values of similar materials increase with increasing overburden stress, the corrected N-value is often normalized to 1-atmosphere effective overburden stress by using overburden normalization schemes. This normalized value is described below.

$$N_{160} = N_{60} * C_N$$

$$C_N = [0.77 * \log_{10}(40/p'_o)] \text{ and } C_N < 2.0 \text{ (Peck, et al., 1974)}$$

$p'_o$  = the vertical effective pressure at the depth where the SPT test is performed (ksf)

### 9.2.3.2 Friction Angle Correlation

As discussed previously, the N-values measured in the field ( $N_{\text{field}}$ ) will likely require corrections or adjustments. Once the corrections are completed, various published correlations estimate the angle of internal friction of cohesionless soils based on SPT-N values and effective overburden pressure. Some of these correlations are widely accepted as representative; whereas, others are more likely to overestimate lab test data. In the absence of laboratory shear strength testing, internal angle of friction estimates for cohesionless soils, based on N-values, must not exceed the values proposed by Peck, 1974 (see [Figure 11](#)). These values are based on SPT N-values obtained at an effective overburden pressure of one ton per square foot. The correction factor,  $C_N$ , as discussed in Section [9.2.3.1.2](#) may be used to “correct” N values obtained at the overburden pressures other than 1 tsf. Caution is advised in soils that exhibit coarser gravel, cobbles, or boulders as these conditions may artificially inflate the field N-values and erroneously increase the angle of friction correlation between these parameters. Also, be cautious of the temptation to use the upper values of these ranges, especially in cases where the location and geologic deposition of the material being used on the project is unknown at the time of the design analysis. For additional information on correlating SPT to the internal angle of friction for cohesionless soil, refer to the Federal Highway Administration (FHWA) *Evaluation of Soil and Rock Properties* (FHWA-IF-02-034) publication.

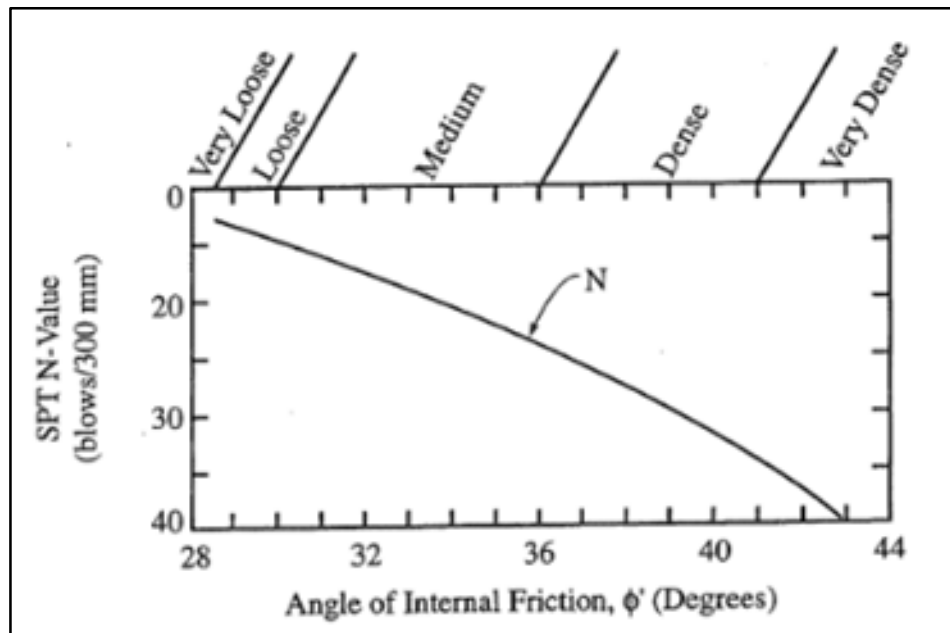

Figure 11: Angle of Internal Friction vs. N-value (After Peck et al, 1974)

#### 9.2.4 SHEAR STRENGTH OF COHESIVE SOILS

For design analysis of short-term conditions in normally to lightly overconsolidated cohesive soils, the undrained shear strength is commonly evaluated. Preferred methods to determine these values are either in-situ testing or laboratory testing of undisturbed samples. Laboratory testing such as unconfined compression tests or unconsolidated undrained (UU) triaxial tests are commonly used to estimate this soil parameter. Strength measurements from hand torvanes and pocket penetrometers can also be useful in estimating the undrained shear strength but should not be solely used in the geotechnical design of critical elements.

Long-term effective stress strength parameters of clays should be evaluated by consolidated drained direct shear tests, consolidated drained (CD) triaxial tests, or consolidated undrained (CU) triaxial tests with pore water pressure measurements. The use of these tests should be determined by the Geotechnical Engineer based on the criteria in Section 9.2.2 and complexity of the project.

#### 9.2.5 SELECTION OF DESIGN PROPERTIES FOR ENGINEERED MATERIALS

This section provides guidelines for the selection of soil properties that are commonly used on MDOT projects. The engineering properties are based primarily on gradation and compaction requirements, with consideration of the geologic source of the fill material typical for the specific project location.

##### 9.2.5.1 Embankment, Compacted in Place

Per the *MDOT Standard Specifications*, Embankment, CIP may consist of “sound earth,” which is defined as “a natural, or otherwise Engineer-approved material, that can be

compacted to the required density, contains no organic material, and has a maximum unit weight of at least 95 pounds per cubic foot.” For this type of material where the gradation specification is fairly broad, a wider range of properties will need to be considered by the Geotechnical Engineer during the design analysis.

In certain types of projects such as Design Build projects or Construction Management-General Contractor (CMGC) projects, the source of sound earth may be known, and sampling and specific laboratory testing may be viable to ascertain appropriate property selection. However, in most MDOT design projects, the source of sound earth is unknown and reasonable assumptions must be made by the Geotechnical Engineer when checking the roadway design, specifically overall stability of fill sections. To provide a sound and consistent methodology for determination of shear strength parameters of proposed embankments **that are not yet constructed**, the following parameters summarized in [Table 12](#) should be used in the design analysis unless site-specific data is available. These values should not be used to analyze stability in existing embankments. When considering roadway projects that consist of both cuts and fills, it is recommended to obtain bulk samples of the cut areas and conduct appropriate laboratory tests to obtain site-specific soil parameters. Although this may not be the exact source of borrow material used by the contractor, it may be more indicative of borrow sources in that area and, as a result, better estimate soil parameters used in the design analysis.

Table 12: Estimated Shear Strengths and Unit Weights for Preliminary Embankment Analysis

Material	Moist Unit Weight	Total Stress (short term)		Effective (long term)	
	$\gamma_m$ (pcf)	c (psf)	$\phi$ (deg)	$c'$ (psf)	$\phi'$ (deg)
Embankment, CIP - Cohesive	125-130	1000-1500	0	50-100	24-30
Embankment, CIP – Granular <sup>1</sup>	120-125	0	32-34	0	32-34
Structure Embankment	120-125	0	32-34	0	32-34
Structure Backfill	120-125	0	32-34	0	32-34
Select Backfill	120-125	0	32	0	32

<sup>1</sup> Granular embankment is a soil that has 15 percent or less passing the No. 200 Sieve.  
 c = undrained shear strength,  $c'$  = effective shear strength,  
 $\phi$  = angle of internal friction,  $\phi'$  = effective angle of internal friction

#### 9.2.5.2 Structure Embankment

The pay item for Structure Embankment per the *MDOT Standard Specifications for Construction* consists of a Class III granular material meeting the gradation specified in Table 902-3. Although this is granular material, the specification allows for a wide range

of gradations from only sand, to gravel, to an assortment of sand, gravel, and fines (passing #200 sieve). Fine content can range from 0 to 15 percent.

With such a wide variation in gradation, angles of internal friction between 32 to 40 degrees are possible when the soil is well compacted. [Table 12](#) provides recommended soil properties to use for the design analysis. When the source of the material is unknown, it is not prudent to select a design friction angle that is near the upper end of the range unless quality assurance testing is specified and conducted during construction. In such cases, the Geotechnical Engineer must look at this conservatively and use the lower end of the range provided.

This material is typically used beneath a spread footing. Common scenarios where this material is used with a spread footing are illustrated in *Bridge Design Guide* 5.45.1.

#### 9.2.5.3 Structure Backfill

The requirements for Structure Backfill ensure that the mixture will meet MDOT's Class II gradation. The materials are likely to be poorly graded sand and contain enough fines to be moderately moisture sensitive. Depending on the location in Michigan, the specification allows up to 7 to 10 percent fines. Lab testing and experience on material that meets Structure Backfill gradation requirements indicate that drained friction angles of 32 to 40 degrees are possible when the soil is well compacted. However, these values are highly dependent on the geologic source of the material. The granular soil in Michigan has typically been glacially derived, resulting in subangular to angular soil particles. Hence, these angular particles tend to have higher shear strength values. However, the windblown, beach, or alluvial sands are generally rounded through significant transport and could have significantly lower shear strength values. Caution should be used when assigning strength parameters to these sands. For use on MDOT projects, a range of values for shear strength based on previous experience for Structure Backfill is provided in [Table 12](#). MDOT recommends using internal angles of friction of 32 to 34 degrees in design if specific lab testing on specific borrow source is unavailable. For all analyses, all granular material must be modeled with zero cohesive strength.

#### 9.2.5.4 Select Backfill

Select Backfill consists of granular material meeting MDOT's Class II gradation. It is used behind permanent or temporary mechanically stabilized walls. For permanent walls, the material must also meet the electrochemical requirements of the special provision. An angle of internal friction equal to 32 degrees should be used for design analysis. For all analyses, all granular material must be modeled with zero cohesive strength.

### 9.3 ROADWAY

Once the field investigation is complete, the Geotechnical Engineer has the task of compiling all the data and analyzing it to determine its effect on pavement design, drainage, stability, and roadway plan preparation. To better acquaint the Geotechnical Engineer with design problems and analysis methods used in this endeavor, the following discussion for the application of the soil data is presented.

#### 9.3.1 SOIL MAP, PROFILE DRAWINGS, AND CROSS-SECTIONS

When constructing a new roadway or reconstructing an existing roadway, it is important to understand where the final roadway profile and proposed subgrade elevation fall in relation to the soils and groundwater and frost depth on the site. As part of understanding this relationship, it is beneficial for the Geotechnical Engineer to first plot the soil borings on the roadway profile sheet, which shows the existing ground surface, proposed final road grade, approximate subgrade elevation, and soil borings with water depth all plotted to scale. It is also important to note the expected high water table even though it may be different than that encountered during the actual field investigation. For considerations in determining the final road plan and profile, refer to Section [9.3.2](#). Once this is completed, the soil at the subgrade elevation can be determined and limits of similar subgrades (soil types) plotted on a plan view drawing. Depending on the project size, it may be beneficial to overlay an aerial map and U.S. Department of Agriculture soil survey of the project area on the plan view area as well. Some of the overlays may have already been done at the subsurface investigation phase and could be reused at this time (see Section [5.1.2](#)). If not already done in the earlier stages of planning, having the road designer develop a series of cross-sections or a corridor model of existing and proposed conditions can be beneficial to understanding the overall project and what is required for further analysis and subsequent recommendations. In critical areas, such as areas of poor soils or large cuts and fills, plotting the soil borings on the cross-section or as a 3D cell with the corridor model as a reference further develops this understanding and aids in future analysis and planning.

After a review of these drawings and an understanding of the soils and groundwater depth is developed across the site, discussion may be necessary between the Geotechnical Engineer and roadway designer if concerns arise regarding drainage, unsuitable soils, or stability. Adjustments to the alignment(s) may be warranted depending on the severity of the issue and site constraints. These drawings will aid the Geotechnical Engineer in formulating final recommendations.

#### 9.3.2 ROADWAY PLAN AND PROFILE

The plan and profile are the medium for adjusting the proposed cross-section to the existing topography. When grade checking the plan and profile, the Geotechnical Engineer should check the items in which soil texture and soil topography have a direct influence. Such items are briefly discussed in the following paragraphs.

*Fill* – The height of a fill above groundwater table, the high-water mark of rivers at flood stage and known high levels of the Great Lakes and inland lakes is very important. The field investigation, past observations, and existing county soil surveys provide the information regarding groundwater tables; the elevation of high water on streams and rivers and lakes is recorded and is also readily available to the designer. During the early design phase, the Geotechnical Engineer is concerned with the height of fill grades above groundwater and above the high-water mark in the smaller streams. The policy for new construction is to establish plan grades at a minimum of five feet above the yearly maximum groundwater table. When water table soundings have been taken during the dry season of the year, the geotechnical report should also include an estimate of the yearly maximum water table. For reconstruction projects that do not meet this criterion, it may be prudent to increase the grade in these areas. In cases where grade controls are such that it is impossible to maintain the minimum grade height, underdrains are used to lower the water table to five feet below plan grade assuming there is positive drainage available. The fill grade should be established at a minimum of two to four feet above the high-water mark of small streams depending upon the type of highway being considered. Where a choice must be made between a raise of grade and the placing of underdrains, the grade raise is always preferable and, in most cases, improves the vertical alignment. The elevation of existing structures, ravines, small streams or any low areas should be examined to determine the suitability of such features as outlets for underdrains placed at five and one-half feet below pavement grade.

When the project being grade checked follows an existing road, grade raises over undesirable soils are common. These grade raises may vary from a five-foot raise, controlled by a high water table, to a minimum one-foot raise over an old pavement where the water table is not a factor. A grade raise with granular material is desirable wherever possible.

The material available for fill construction will generally influence the cross-section and the method of construction. Underwater fills and fills in all places where the operation of compaction equipment is difficult should always be constructed of granular materials.

*Cut* - The soil through cut sections is the material that will be used for adjacent fills, and the soil type indicates the necessity for subbase, the estimated quantities of subgrade undercutting, and drains. These items should be checked and, where the design varies from the standards, a careful study should be made to determine whether objectionable features introduced by the variation have been adequately considered. Sand-over-clay soils, depressed sections such as underpasses, dump areas, deep cuts, and swamps must be checked carefully to determine whether sufficient drainage has been provided.

### 9.3.3 ROADWAY SUBGRADE

The supporting ground beneath a pavement structure is called the subgrade. The subgrade is located below the pavement and base and subbase courses. It extends to such depths as may be important to structural design and pavement life, and it may consist of materials in excavations (cuts) or embankments (fills). This section addresses the primary geotechnical attributes of subgrade soils that the Geotechnical Engineer should be cognizant of during the design process. It is not the intent of this section to provide pavement section analysis or design guidelines; that is covered in the *Pavement Selection Manual* and *MDOT User Guide for Mechanistic-Empirical Pavement Design*.

#### 9.3.3.1 Subgrade Design Value Determination and Recommendations

Once the elevation and soil type of the proposed subgrade is known, recommendations for pavement design and construction are provided by the Geotechnical Engineer. The *MDOT User Guide for Mechanistic Empirical Pavement Design* requires the Geotechnical Engineer/region soils engineer to provide the subgrade resilient modulus value as an input to the pavement design analysis. This value(s) can be determined one of three ways: back calculation using the falling weight deflectometer tests, historical correlations using visual observation of the soil type, and/or laboratory testing. The method to use in determination of this value should be discussed with the region soils engineer and roadway designer prior to the field investigation (MDOT performs field investigation) or prior to formulating a proposal for advertisement (consultant performs field investigation). It is common to have an additional geotechnical scope of services as part of the Request for Proposal when the design/investigation is performed by a consultant. Although one subgrade resilient modulus value is commonly reported on most projects, a new alignment or reconstruction project of considerable length may have varying subgrade soil types and, therefore, warrant reporting more than one value. A cost analysis can then be made to determine if multiple pavement section designs are warranted and should be used on the project. For current design procedures, refer to the *MDOT User Guide for Mechanistic-Empirical Pavement Design*.

#### 9.3.3.2 Problematic Subgrade Conditions

Since roadways traverse across long distances and over many soil types and differing geologic depositions, it is not surprising that conditions arise that are not conducive to support, or even construction, of pavement systems. In cases where the subgrade is inadequate, methods of improving the existing subgrade conditions must be identified. Inadequate subgrade may consist of silt, silty sand, organic laden soils (swamp deposits), saturated soils, or soft to very soft soil. In summary, objectionable subgrade materials requiring correction fall into one of two broad categories: soils of low bearing capacity and frost heave textured soils or conditions that cause detrimental pavement heave. Discussion of these problematic areas is provided in the following sections.

An important part of this evaluation is the balance between construction costs and long-term operational costs. This balance is best resolved through direct discussions between the Geotechnical Engineer, roadway designer, and/or Pavement Management Section.

#### 9.3.3.2.1 Weak Subgrade

Soft to very soft clay soil, organic soils (peat marl), silt, or fine sand with high amounts of silt could be problematic due to their compressibility or lower bearing capacity characteristics. Compressibility of the clay soils may be an issue if fills are being placed upon it or if they are relatively close to the wheel load. Further discussion of subsoils subject to compressibility concerns are discussed further in Section [9.3.7](#). Low strength subgrade will increase the pavement section thickness and/or create constructability issues. It is best to recognize and account for these potential issues during the design phase. MDOT has addressed these conditions using the following methods:

- Subgrade Undercutting,
- Subgrade Manipulation,
- Treatment of Peat Marshes,
- or Chemical Subgrade Stabilization

Treatment of peat marshes is discussed in the following section. Details and pay items for subgrade undercutting and manipulation are discussed further in the *Standard Specifications for Construction* while chemical stabilization will require a special provision. If chemical treatment of the subgrade is being considered, contact the region soils engineer for more information on this topic and its feasibility. Chemical analysis of the soil is required in design if stabilization through chemical methods is used.

Another area that has potentially weak subgrade or nonuniform soil is in cut to fill transitions. These areas can be identified during the design phase and are usually treated through subgrade undercutting. An undercut detail for cut to fill transitions is illustrated below. The A and B Horizons illustrated in [Figure 12](#) can be defined as follows.

*A Horizon* – The uppermost layer of a soil profile from which inorganic colloids and other soluble materials have been leached. Usually contains remnants of organic life.

*B Horizon* – The layer of a soil profile in which material leached from the overlying A Horizon is accumulated.

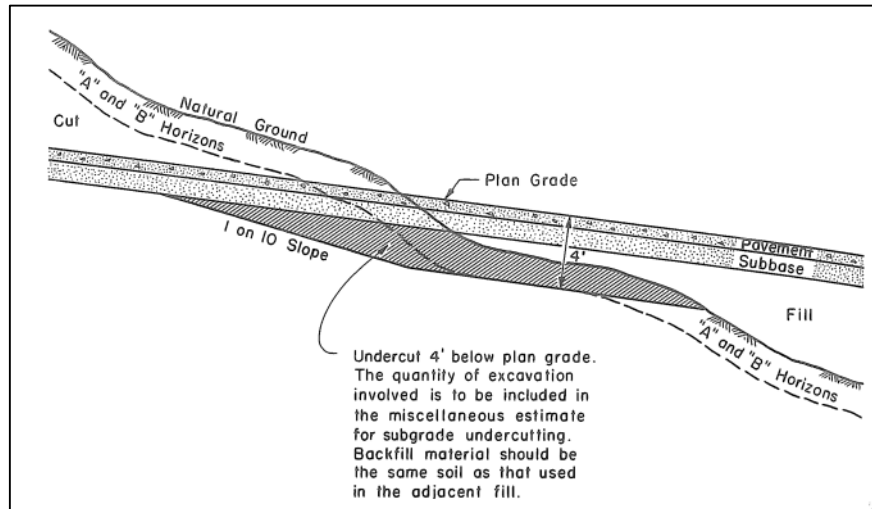

Figure 12: Cut to Fill Transition Undercut

#### 9.3.3.2.2 Peat Marshes

Organic soils such as peat, marl, and very soft clay (either organic or inorganic) have properties that can be characterized as having low shear strengths and high compressibility. The characterization and classification of these soil types are discussed in Sections 7 and 8. If these soil types are encountered during the field investigation, the Geotechnical Engineer should review the data and determine if additional boring depth and frequency above the minimums stated in Section 6 are warranted. Since the properties of these soils cause undesirable roadway performance, soils that fall into this category and are present within the roadway limits are typically removed and backfilled with suitable material. Even existing roadways that have been constructed over organic soils, specifically peat, will continue to see secondary settlement many decades after the initial stress increase was applied. **As such, roadway reconstruct projects where these conditions exist should be conservatively scoped for removal and replacement** with further investigation, analysis, and recommendations by the Geotechnical Engineer on the appropriate course of action during the design phase. Furthermore, increases in vertical alignment and roadway width will result in increased total settlement, which may be uniform or differential. These increases may also create stability issues, which are discussed further in Section [9.3.7.3](#).

Where these poor soils are encountered within the roadway alignment, [Standard Plan R-103-C](#), Treatment of Peat Marshes, provide three basic methods for treatment. The details provide guidance for undercuts in organic and very soft soils that have over time been proven to work. However, the Geotechnical Engineer is still responsible for checking the stability of these excavations to ensure appropriate factors of safety exist for that specific project site. Some situations where modifications to these standard details may be required are the following:

- Peat excavations deeper than 15 ft;
- The swamp bottom is sloping;
- Fills placed through peat excavation areas that are 15 ft or greater in height; or
- A combination of these scenarios.

#### 9.3.3.2.3 Frost Susceptible Soils

As ground temperatures decrease to below freezing, water within a soil mass freezes and undergoes a volumetric change as a result of the water-to-ice phase change. Lenses of frozen water form in this zone and draw additional moisture upward through capillary action that in turn freeze and expand. The movement or displacement associated with this process is termed frost heave. When thawing occurs during a warm period after freezing or during the spring thaw, the soil that expanded then resettles to its original position. In addition, as the frozen soil thaws from the surface downward, the excess moisture from the thawing ice lenses will cause a loss of strength and stability in the thawing soil leading to insufficient pavement support. This back and forth movement, which causes stress in the pavement section, is referred to as frost action. While pavement sections are designed to accommodate certain levels of stress and corresponding deflections, the larger the deflections and the greater number of stress cycles adversely affects the pavement section life expectancy.

Frost action can cause differential heaving, surface roughness and cracking, blocked drainage, and a reduction in bearing capacity during thaw periods. Three conditions must exist to cause frost heaving and associated frost action problems:

- Frost-susceptible soils,
- Subfreezing temperatures in the soil, and
- A source of water.

In general, silts, clays with high percentage of silt particles, and fine silty sands are highly frost susceptible. If encountered during the field investigation, treatment of these areas must be addressed in the design process.

[Table 13](#) provides a summary of the soil type and frost susceptibility classification based on research by the Federal Highway Administration.

When designing the pavement section in cold climate regions, three design approaches have been used to mitigate frost action:

1. Complete Protection approach: requires the use of non-frost susceptible materials for the entire depth of expected frost penetration.

2. Limited Subgrade Frost Penetration approach: permits some frost penetration into the subgrade, with the intent of not allowing unacceptable surface roughness and premature pavement distress/life expectancy to occur.
3. Reduced Subgrade Strength approach: allows more frost penetration into the subgrade but provides adequate strength during thaw weakened periods.

Table 13: Frost Susceptibility Classification of Soils (NCHRP 1-37A, 2004)

Frost Group	Degree of Frost Susceptibility	Type of Soil	Percentage of Finer than 0.075 mm (#200) by wt.	Soil Classification
F1	Negligible to Low	Gravelly soils	3-10	GC, GP, GC-GM, GP-GM
F2	Low to Medium	Gravelly soils	10-20	GC, GP, GC-GM, GP-GM
		Sands	3-15	SW, SP, SM, SW-SM, SP-SM
F3	High	Gravelly Soils	Greater than 20	GM-GC
		Sands, except very fine silty sands	Greater than 15	SM, SC
		Clay, PI > 12	–	CL, CH
F4	Very High	All Silts	–	ML, MH
		Very Fine Silty Sands	Greater than 15	SM
		Clays PI < 12	–	CL, CL-ML
		Varied clays and other fine grained, banded sediments	–	CL, ML, SM, CH

Currently, *MDOT's Standard Specifications for Construction* uses the term Frost Heave Textured Material, which is defined as soil with 50 percent silt particles (0.002 to 0.075mm) and a plasticity index less than 10. Any soils encountered within the subgrade meeting these parameters require removal to minimum depths of 3.5 to 4 ft south of the northern line of Township 12 North and 4 to 5 ft in geographical areas north of that same line. **It is recommended that the higher end of those ranges be used in current practice, especially in areas of high-volume traffic and deeper frost depths.**

Alternatively, if removal is not feasible or reasonable, then subgrade stabilization can be considered. This consideration should be made in partnership with the MDOT central office.

Based on this current practice, one could say MDOT uses a "Limited Subgrade Frost Penetration" approach where the current pavement design section permits some frost penetration into the subgrade. The most frost susceptible soil (frost heave textured material) is removed to depths of 3.5 to 5 feet while other subgrade soils, even though

they could be highly frost susceptible, may not result in movements of a magnitude detrimental to the pavement's performance.

Nevertheless, it is advised that the Geotechnical Engineer consider how past pavement performance and water depths in areas where these highly frost susceptible soils are present could affect the future design. In addition, limited research has shown that soils with 2.0 inches/foot of frost heave may lead to unacceptable effects on pavement performance and life expectancy. However, soils that normally would not be classified as frost heave textured materials could exceed the 2.0 inches/foot criterion. For instance, soils such as clays with plasticity indices less than 15 and silty clayey sand would not necessarily be classified as frost heave textured material but are highly frost susceptible and certain gradations would not meet this criterion. **As such, Geotechnical Engineers may consider using more selective criteria in defining frost heave textured materials as soil that is 50 percent passing the #200 sieve and has a plasticity index less than 15.** If this approach is selected, the Geotechnical Engineer should specify estimated limits and quantities to address these soils.

As an alternative, areas that have high frost susceptible soils but do not necessarily meet the requirement of Frost Heave Textured Material, raising the grade or installing drains to remove water could also be considered. Normally, establishing the final grade four to five feet above the high-water level or installing subgrade drains to a similar depth so that the source of water is cut off can significantly decrease the detrimental effects caused by frost susceptible soils. In urbanized areas where reconstruction of the roadway is proposed, it may be challenging or cost prohibitive to raise the grade to this extent due to the high density of existing building and utility infrastructure. In these situations, a drainage system and/or subgrade undercutting may be more viable options in treating these problematic soils.

If evaluating past pavement performance of the existing roadway indicates damage caused by frost heave, then additional subgrade treatment may be warranted and should be set up in the design plans. In areas of new roadways or realignments, raising the grade so that a minimum separation of five feet exists between the roadway surface and highly frost susceptible soils is also preferred and should be considered a prudent practice when designing and constructing MDOT roads.

For more information on frost susceptible soils, refer to the FHWA Geotechnical Aspects of Pavements Reference Manual, Publication No. FHWA NHI-10-092 and the research report Predictive Modeling of Freezing and Thawing of Frost-Susceptible Soils by Michigan State University, Baladi and Rajaei, Report No:RC-1610.

*Undercut Limits* - The width of the undercut excavation varies with the extent of the deposit of undesirable material. Where the material extends entirely across the grade, the excavation is made to lines approximately two feet outside the edge of pavement. In general, good practice is to undercut entirely across the roadway width even if the undesirable material is only present in a portion of the roadway cross-section. This practice is to prevent the potential for differential frost heave that sometimes occurs when materials of different texture or moisture content are placed directly adjacent to one another (see *Texture Changes* paragraph below). If underdrains are present outside this horizontal limit, the undercut must extend out to this line. At each end of the undercut, the excavation must be extended so that there is a gradual transition from full depth cut to original subgrade surface. The transition at each is generally 25 to 50 ft long depending on the depth of the undercut. A 1:10 ratio (cut: distance) with a minimum of 25 feet is a good rule of thumb when transitioning in these areas.

Where granular backfill is used in an area of clay soils, it is necessary to provide drainage for water that would otherwise accumulate within the material. To accomplish this, it is necessary to undercut to the ditch or provide an underdrain where there is no ditch, or the bottom of the excavation is below the ditch line.

*Texture Changes* - Frost heave also occurs where there is an abrupt change in soil texture. The heave in this case is due to the different natural moisture contents of the soils. Those soils having a high natural moisture content, such as clay and silt, expand considerably more upon freezing than do granular soils having a lower natural moisture content. Hence, differential frost heaving can take place where an abrupt change in soil texture occurs.

The abrupt change in texture is generally a simple matter to correct. The condition is corrected by selective excavation and replacement of acceptable backfill where only a few small deposits are involved. Another less used option that could possibly be utilized is to thoroughly mix the two soils where the variation is sufficiently extensive that excavation of individual areas is not practical. Again, appropriate transition zones should be used in these excavated areas. The mixing operation is generally accomplished with scrapers by excavating half width of the area and stockpiling. Material from the remaining half is then excavated and placed in the half already removed. The stockpiled material is then used to complete the backfill. Handling of the excavated material is limited to one and one-half times by this method. However, it seems mixing of the soils is less used and being phased out of general construction practice.

### 9.3.3.3 Potholes

Potholes are formed due to a localized loss of support of the surface course through either a failure in the subgrade or base/subbase layers. Potholes are often associated

with frost heave, which pushes the pavement up due to ice lenses forming in the subgrade during the freezing period. During the thaw, voids (often filled with water) are created in the soil beneath the pavement surface due to the melting ice and/or gaps beneath the surface pavement resulting from heave. When vehicles drive over this gap, high hydraulic pressure is created in the void resulting in high pore water pressure that ultimately weakens the surrounding soil. The road surface cracks due to the weakened soil and tire load and then falls into the void, leading to the formation of a pothole.

Potholes or joint faulting can also occur as a result of pumping water at joints in concrete pavement. This scenario occurs when repeated, heavy tire loads are transferred from one pavement slab to the adjacent one under the following two principal conditions: 1) lack of effective load transfer from slab to slab across the joints, and 2) the presence of water under the slab. [Figure 13](#) and [Figure 14](#) illustrate the mechanism by which this occurs.

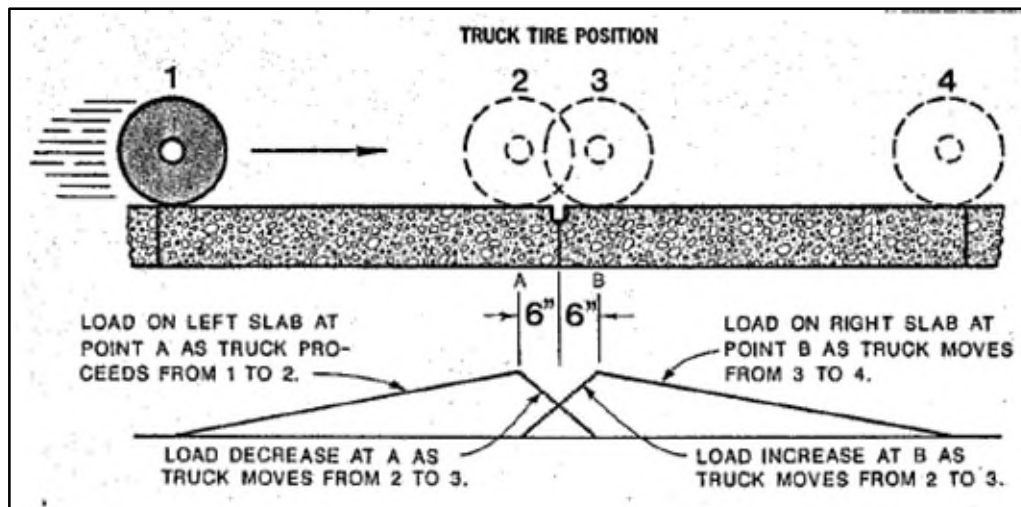

Figure 13: Load Transfer from Axle Loads on Concrete Joints (After MATES, Issue No. 14)

Figures 12 and 13 illustrate a tire load moving over a joint that is either without or has ineffective load transfer devices and is resting on a water filled base material. As it approaches the joint traveling from position 1 to 2, the load under the left side of the joint (at point A) increases from zero up to the full weight of the axle, while simultaneously, the water under the slab is being squeezed forward of the truck axle and pushed beneath the right-hand slab, as illustrated in [Figure 14](#). In approximately one-hundredth of second, the axle load is transferred from the left to the right slab. During this transition, the vertical load at the end of the first slab immediately drops to zero while the vertical load on the beginning of the second slab suddenly rises from zero to its maximum value at B, thereby rapidly expelling the just accumulated water backward under the end of the first slab. That slab, now unloaded, recovers from its deflected position, creating a void. Note that, although the same load rolls over points A

and B at the same speed, the rate of load application at B is about 20 times the rate at A. The ability of the rapidly flowing water to remove particles of soil is substantially enhanced by its increase in velocity since the largest particle size that can be moved by a stream of water is proportional to the square of the water's velocity. That is, if the velocity doubles, the size of the particle that can be moved is quadrupled. Pieces up to 1/8 inch in diameter have been found to move in this manner.

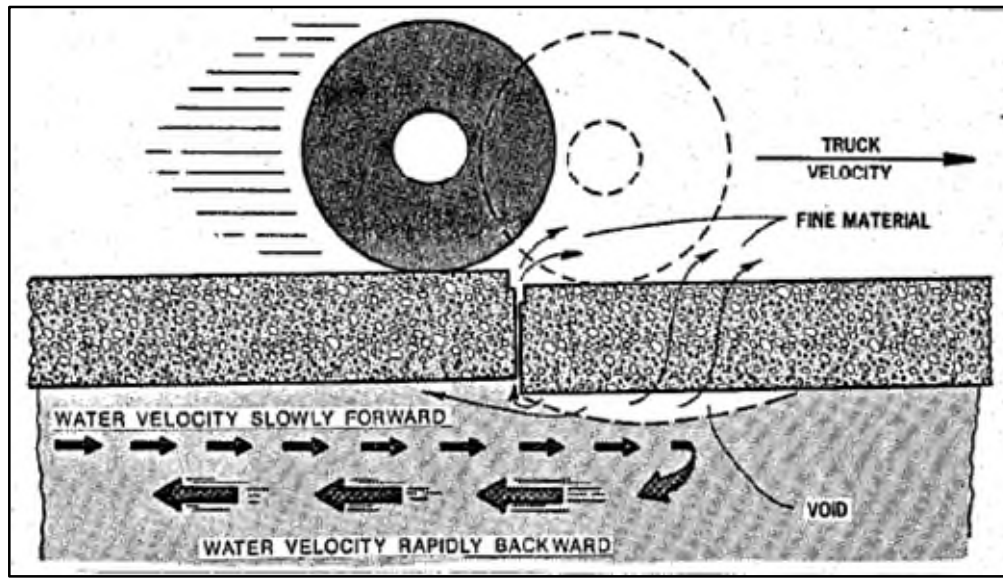

Figure 14: Pumping Water at Joint (after MATES, Issue No. 14)

As a result of the high rate of loading and previous forward water flow, significant quantities of water are rapidly ejected back from under the end of the second slab, carrying more soil with them than they carried when they came forward, producing the void shown in [Figure 14](#). Simultaneously, a portion of the water with finer materials in it may be squeezed or “pumped” up through the transverse and shoulder joints, removing more material from beneath the pavement. This process, continually repeated with the passage of numerous trucks, in the long run results in subsidence near the joint and eventual slab cracking or formation of a pothole.

In roadway sections where potholes readily occur, additional investigation is warranted to determine the cause of the pavement deterioration. Undercuts of the subgrade and/or implementing additional drainage of the subbase and subgrade may be needed to prevent future occurrence.

#### 9.3.3.4 Impact of Water Seepage and Drainage on Subgrade

The damaging effects of excess moisture on the pavement section have long been recognized. Moisture, in combination with heavy traffic loads and freezing temperatures, can have a profound negative effect on both material properties and the

overall performance of a pavement system. Water may seep upward from a high groundwater table or it may flow laterally from the pavement edges, cut slopes, and shoulder ditches. Knowledge of groundwater and its movement are critical to the performance of the pavement, as well as stability of adjacent side slopes, especially in cut situations. Groundwater can be especially troublesome for pavements in low-lying areas. Thus, groundwater control, usually through interception and removal before it can enter the pavement section, is an essential part of pavement design.

Removal of free water in pavements can be accomplished by draining the free water vertically into the subgrade or laterally through a drainage layer into a system of underdrains. If the subgrade already consists of free draining soil, like on some roads in the western portion of the Lower Peninsula or where poor draining subgrade has already been replaced with free-draining material and drainage, then implementation of a drainage system may not be necessary. An exception to this is discussed in the In-Slope Drainage paragraph below. In cases where the existing roadway, widening, or new roadway has no way for subsurface or surface water that enters the pavement section from being removed, appropriate measures to implement underdrains need to be addressed in the design phase. [Standard Plan R-80](#) series provides drainage options for pavement section and slope design. These items of work are typically incorporated in the project design by 1) discovery during the field investigation and specifically locating the area to implement the drain or 2) providing a miscellaneous quantity to allow for wet areas that cannot be definitively anticipated during design but identified during construction by field staff.

*Subbase Drains* - Subbase drains serve to provide drainage of the subbase course throughout the entire roadway section. In wider roadways, several subbase drains may be required. Common practice is to place a minimum of two per roadway but not greater than 30 ft center-to-center and not under wheel loads. Spacing determination could be based on permeability of subbase used in that area of the state and desired time for removal of water, subgrade slope as it may affect drainage path distance, and potential amount of water that may need to be removed from the section.

*Subgrade Drains* - Subgrade drains are placed adjacent to the pavement for the purpose of lowering a high groundwater condition and/or for the purpose of draining the granular subbase. Where grades may not be raised consistent with good vertical alignment, subgrade drains are required. In areas of a level or consistent water table, this treatment is not as desirable as raised grades because topography and outlet facilities generally do not allow the placing of drains at suitable depth and gradient. Where consistent or seasonal water tables are high and where outlets are available, deep drains, preferably at a minimum of five feet below pavement grade, may be placed per the standard plan. The number of drains required depends on the elevation of the

water table and width of grade. Spacing and depth should be determined so as to lower the water five feet below the bottom of pavement.

*Bank Drains* - Water seepage encountered in cut slopes must be intercepted by drains before it daylights on the slope face or reaches the subgrade. While in some cases a subgrade drain, if placed and designed appropriately, can be used as dual purpose, the use of a bank drain may be better suited to intercept seepage water before it reaches the subgrade or subbase. When cuts intercept groundwater in rolling topography, the underground water surface is usually on a gradient. Where the gradient of the water surface is across the roadway, drains placed on the high side will usually suffice. Where the probable direction of flow is longitudinal or skewed, drains may be placed on one side with one or more laterals to intercept water five feet or more below the bottom of pavement.

*In-Slope Drainage – “Day-lighting”* - Extreme caution is advised in areas where it is assumed that the pavement section will be daylighted horizontally through the subbase onto the fill slope or into the ditch. In some cases, the contractor places clay on the outside edge of the slope or low permeability topsoil, which can limit or block the drainage path of the base and subbase courses. Essentially, the drainage system’s capacity is limited by the least permeable material that the water must pass through. In a true daylighted section, the base and subbase extend to the slope face. The *FHWA Geotechnical Aspects of Pavements* notes that the daylighted sections must be periodically maintained free from fines, soil, vegetation, and other debris.

It is advised that pavement sections be designed to address these conditions from happening by either installing edge/subbase drains or ensuring the subbase and base courses are detailed on the plans and constructed in the field so that horizontal drainage can occur. Also, ditches should be designed to keep water below the daylighted area, especially during times of high rain events and spring thaws. The Geotechnical Engineer is responsible to work with the design engineer ensuring suitable drainage occurs.

#### 9.3.4 SLOPE SLOUGHING

The occurrence of seepage in the backslopes of cut sections is a common problem when certain soil conditions are present in these areas. If not addressed, the seeping water will result in continual erosion and sloughing of the slope. Sometimes substantial quantities of vegetation and surface soil can slide downslope. Typically, the slough is surficial in nature and not a deep-seated movement. A picture of a soil slough is illustrated in [Figure 15](#). During the design phase, the Geotechnical Engineer should be aware of soil conditions that could create sloughing issues. A few of these conditions are discussed in the following paragraphs.

One condition conducive to exit seepage is where a pervious material is underlain or surrounded by an impervious soil. Generally, it occurs at the contact line where sand overlies clay. If the contact line between the two strata is uniform, a bank drain placed on the slope to intercept the water prior to it reaching the slope surface will usually suffice in remediating this condition. Where irregular sandy pockets or irregular flow conditions exist across a slope face, it is often difficult to place bank drains effectively. Granular blankets have been found to be a more effective remedial drainage measure and are discussed more thoroughly in Section [9.3.3.4](#).



Figure 15: Soil Slough in Spring

Slope sloughing also occurs during the spring thaw where silt soils are exposed in the backslopes. During freezing weather, additional moisture is attracted to the frozen slope surface. In the first warm days of spring, the excess moisture is rapidly released creating a condition of semi-fluid soil, which tends to flow down the surface of the slope. Whenever silt is exposed on steeper slopes, it should be undercut and replaced with a granular blanket as detailed in [Standard Plan R-80 Series](#).

Another scenario to consider in design is where an existing roadway constructed of granular embankment is widened to accommodate additional lanes/shoulders. To ensure the existing granular embankment is allowed to drain, fill associated with the widening should consist of Granular Material Class II or III.

When these conditions exist, the Geotechnical Engineer must provide appropriate treatment limits and associated quantities within the contract documents. During some projects, soil conditions such as these may not be defined during the design phase. However, it is prudent for

the Geotechnical Engineer to specify miscellaneous quantities based on experience with the soils encountered within the project limits.

### 9.3.5 CULVERTS

The size and location of the existing and proposed culverts on a project should be checked by the Geotechnical Engineer. Whenever a new culvert is proposed or an existing culvert size and/or location is changed, analysis of the soil borings conducted during the field investigation is performed by the Geotechnical Engineer. Each culvert location should be checked for adequate foundation support and depth of cover over the culvert. Where it is deemed that insufficient foundation support is present, the Geotechnical Engineer will need to provide recommendations concerning special treatments. When checking the depth of cover, experience has shown that a two-foot minimum depth of cover over the pipe is required to preclude objectionable heaving of the pavement. The two-foot minimum dimension is measured from the top of the pipe to the lowest point at the bottom of the pavement. It should be noted that this distance is a minimum and, if possible, additional cover is preferred because it will provide better long-term performance of the roadway.

### 9.3.6 UTILITY EXCAVATIONS

Utility excavations within the roadway right-of-way should be reviewed by the Geotechnical Engineer to see if any unusual soil conditions or structural related issues may exist. Proper bedding and compaction of the utility trench within the roadway is of paramount importance to achieve acceptable rideability and long-term pavement performance. MDOT has developed standard bedding details and compaction requirements to achieve this goal. Proposed excavations near structure footings must be carefully reviewed and recommendations provided by the Geotechnical Engineer to preclude any loss of foundation support.

Based on the subsurface data gathered in these areas, several conditions may exist that require inclusion of certain plan quantities in the design phase. For instance, excavations in saturated granular soil require special considerations for dewatering and/or earth retention to prevent loss of ground. The stability of the excavation close to the traveled roadway may impose a safety risk to the traveling public. Another situation in which the Geotechnical Engineer may need to specify additional quantities is where pits are excavated to facilitate trenchless installation, such as in a jack and bore operation.

Nonconstruction project utility installations within the MDOT right-of-way require approval by means of a formal permit. The permit agent in conjunction with the Geotechnical/soils engineer should advise the applicant about what subsurface information is required and what precautionary requirements should be added to those given in the standard permit form. Utility work involving complex soils and/or specialty installations justifies the Geotechnical Engineer's interest and periodic inspection during progress of the work. For those utility installations

required to be installed using trenchless methods, refer to Form 3702 [Application Requirements for Trenchless Installations](#).

### 9.3.7 ROADWAY SLOPES AND EMBANKMENTS

Many of MDOT's roadway projects require the design and construction of roadway slopes and embankments. In most cases, roadway slopes and embankments will be used to meet grade and alignment requirements in areas of changing topography. However, roadway slopes and embankments can also be used to form temporary access routes or work platforms during construction. This section summarizes procedures that the Geotechnical Engineer should follow when conducting geotechnical studies for roadway slopes and embankments.

Roadway slopes and embankments are considered separately in this section, primarily due to the different geologic conditions that will occur for each:

*Roadway Slopes* – Roadway slopes are defined by the existing geology at a site. They may involve excavation of a cut slope or construction adjacent to a natural slope (See [Figure 16](#)). Relative to the embankment fill, geologic conditions for roadway slopes will normally be more variable.

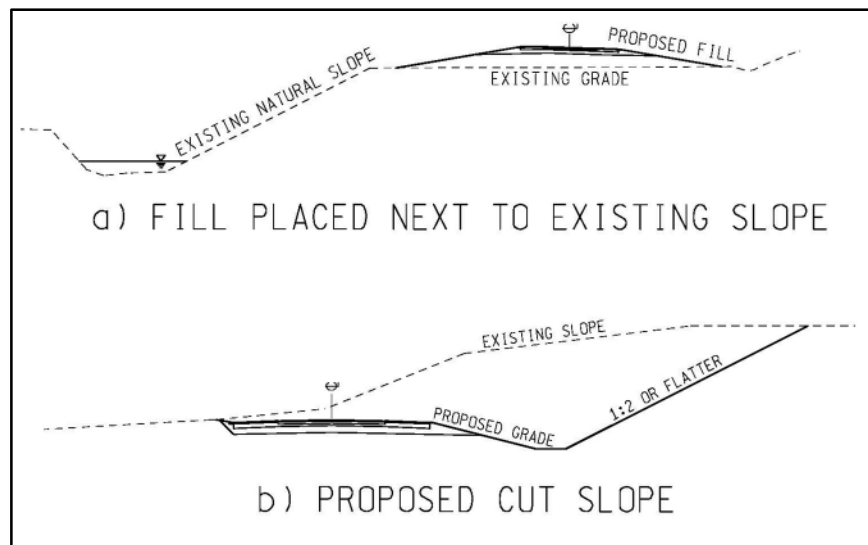

Figure 16: Existing Roadway Slopes

*Roadway Embankments* – Roadway embankments involve fills constructed of engineered material. The embankment fill is either imported from off-site or relocated from another portion of the project and placed on the existing ground. Contract documents specify fill placement, procedures, material requirements, and compaction requirements.

The different geologic conditions for roadway slopes and embankments result in different geotechnical requirements relative to field explorations and engineering design. For example:

- The primary geotechnical concern for roadway slopes is the stability of the slope. The stability assessment requires characterization of geologic layers and groundwater conditions of the existing material. Engineering design activities focus on the evaluation of short- and long-term stability for different groundwater and material strength assumptions. If the factor of safety for the stability of the slope is inadequate, improvement procedures typically involve flattening slopes, drainage improvements, use of a retaining structure, or some type of ground improvement.
- The primary geotechnical design issues for embankments include bearing capacity, slope stability and long-term settlement. These design issues are often controlled by the engineering characteristics of the geologic material below the fill rather than the properties of the fill. Consequently, geotechnical explorations for the embankment focus on characterization of the existing foundation material, and engineering design evaluates how these existing materials respond to the load from the new fill. If an unacceptable response is predicted, methods of improving the soil below the fill to achieve better performance may be required before the fill is constructed.

Thorough geotechnical analyses and design are important for both the roadway slope and embankment. Inadequate consideration of geotechnical design requirements can result in short-term construction and/or long-term operational problems. For roadway slopes, a primary design consideration is the potential failure of slopes during construction. If slope movements are slow, the primary problem could be maintenance requirements to remove earth as it encroaches on the roadway. In the case of embankments, slope stability and bearing capacity failures can occur during construction, causing construction delays and contractor claims. Following construction, settlement beneath the embankment can result in poor ride quality of the roadway, subsequently leading to long-term maintenance requirements and premature pavement failures.

One area of main concern is on fills leading up to bridge abutments. Relatively large differential settlement between the approach embankment and the bridge abutment can create poor ride quality and potential safety issues. This situation is also referred to as the “bump at the end of bridge.”

#### 9.3.7.1 Roadway Design Responsibilities

Responsibility for the design of roadway slopes and embankments primarily resides with the Geotechnical Engineer and the road designer. Other units are involved as necessary.

For roadway slopes and embankments, the Geotechnical Engineer responsibilities are the following:

- Plans and then performs the geotechnical exploration, including the field investigation and laboratory testing;

- Conducts geotechnical analyses to evaluate slope stability for natural and cut slopes and bearing capacity, side slope stability, and settlement for embankments;
- Provides construction recommendations, including subgrade preparation requirements, maximum slope angles for construction and long-term operations, and the need for ground improvement where settlements are excessive;
- Identifies, installs, and monitors instrumentation and develops special provisions for construction as needed; and
- Supports the construction personnel and road design section if construction issues develop.

The roadway designer also has an integral part in this design process. The roadway designer does the following:

- Sets a roadway alignment and grade. Fill/cut slope ratios are generated using preset “standard” slope ratios as defined in the *Road Design Manual*. Right-of-way limits are preliminarily defined by these standard slope ratios. **The Geotechnical Engineer reviews the preliminary slope ratios and provides recommendations for adjustments, where needed, as part of the project design process.** The recommendations for adjustments are based upon geotechnical investigations and analyses, economics, right-of-way considerations, etc. Ultimately, the Geotechnical Engineer and the roadway designer work together to determine the final slope ratios considering these factors; and
- Prepares plans and specifications for construction with input and review by the Geotechnical Engineer.

### 9.3.7.2 Embankment Settlement

New embankments and embankment widenings must be analyzed to determine the effects that settlement may have on the roadway embankment. The ability to accurately quantify both the magnitude and rate of settlement will depend on the thoroughness of the field investigation, quality of laboratory testing, size of the embankment, and consistency of the foundation soils. As the height and width of the embankment increases, the potential for settlement also increases because of the stress change that occurs in the foundation soil. The amount of settlement also increases as the thickness and compressibility of the foundation soil increases.

The magnitude and rate of embankment settlement are important long-term (operational) considerations, particularly where thick deposits of cohesive soil occur. It is important for the Geotechnical Engineer to conduct settlement analyses to determine if the amount of settlement after construction is within the project criteria. If the settlement appears to be excessive, then measures may be required to improve the soil

or that allow a majority of the predicted settlement to occur during construction. This section summarizes methods of analysis for sites under long-term loading conditions.

#### 9.3.7.2.1 Settlement Analysis Methods

Methods discussed in the American Association of State Highway and Transportation Officials (AASHTO) LRFD Bridge Design Specifications (Section 10.6.2), FHWA Soil Slope and Embankment Design Reference Manual, and FHWA Soils and Foundation Reference Manuals should be used to perform detailed settlement analysis for roadway embankments. Laboratory test results from soil samples obtained should be used as a basis for determining the primary and secondary settlement amounts and rates for cohesive soils. Because primary consolidation and secondary compression can continue to occur long after the embankment is constructed (post construction settlement), they represent the major settlement concerns for embankment design and construction. Post construction settlement can damage structures and utilities located within the embankment, especially if those facilities are also supported by adjacent soils or foundations that do not settle appreciably and lead to differential settlements. If the primary consolidation is allowed to occur prior to placing utilities or structures that would otherwise be impacted by the settlement, the impact is essentially mitigated. However, it can take weeks to years for primary settlement to be essentially complete, and significant secondary compression of organic soils can continue for decades. Many construction projects cannot absorb the scheduling impacts associated with waiting for primary consolidation and/or secondary compression to occur. Therefore, estimating the time rate of settlement is often as important as estimating the magnitude of settlement.

The amount and rate of settlement can be calculated by hand or computer programs such as EMBANK (FHWA, 1993) or FOSSA. Alternatively, spreadsheet or MathCADD solutions can be easily developed and used for this purpose.

Settlement calculations can be made for cohesionless soil sites using elastic theory. Typically, this settlement is “immediate” and occurs during construction of the embankment. Therefore, immediate settlement is typically of less concern than either primary or secondary settlement amounts since it occurs prior to final grading and paving operations. Utilize the references stated in the initial paragraph of this subsection when conducting this type of analysis. Use of corrected blow counts from the Standard Penetration Test (SPT) or in-situ methods, such as the pressuremeter, should be used to develop settlement estimates in cohesionless soils. See Section [9.2.3.1](#) for correcting blow count values obtained from the SPT.

#### 9.3.7.2.2 Embankment Settlement Criteria

To establish the target embankment settlement criteria, the tolerance of affected structures or utilities to total and differential settlement must be determined. Lateral movement (i.e., lateral squeeze) caused by the embankment settlement and its effect on adjacent structures, including standard lights, overhead signs and signal foundations, etc., must also be considered. If structures or utilities are not impacted by the embankment settlement, settlement criteria are likely governed by long-term maintenance needs of the roadway surfacing. In that case, the target settlement criteria must be established with consideration of the effect differential settlement will have on the pavement life and profile.

#### 9.3.7.2.3 Embankment Settlement Mitigation

During the roadway design process, there are times where the predicted increase in stress from proposed roadway fill could cause the subsoils to consolidate beyond tolerable limits. Scenarios where stress increases can commonly occur are placing a new embankment on a new alignment, an increase in the vertical profile of an existing roadway, or a widening of the existing roadway embankment. In these cases, some form of mitigation may be necessary so that the pavement section performs as intended and so that total and/or differential settlement does not create premature distress in the pavement and a potential safety issue for motorists using the roadway. For treatment of peat, marl, muck and underlying very soft clay, see Section [9.3.3.2.2](#).

The following paragraphs summarize typical methods MDOT implements to mitigate areas where predicted settlement amounts are outside tolerable limits. It should be noted that special provisions and/or special details on the plans will need to be developed as part of the contract documents if these mitigation methods are used. In addition, [www.geotechtools.org](http://www.geotechtools.org) may also provide some insight into potential mitigation measures for embankment settlement.

*Undercut (over-excavation)* – This method refers to excavating the soft compressible or unsuitable soils from below the embankment footprint and replacing these materials with higher quality, less compressible material. Because of the high cost associated with excavating and disposing of unsuitable soils, as well as the difficulties associated with excavating below the water table, overexcavation and replacement typically only makes economic sense under certain conditions. Some of these conditions include, but are not limited to:

- The area requiring over-excavation is limited;
- The unsuitable soils are near the ground surface and generally extend to a depth of 5 ft or less;

- Temporary shoring and/or dewatering are not required to support or facilitate the excavation or if they are then these costs are included when analyzing this option and;
- Suitable materials are readily available to replace the over-excavated unsuitable soils.

*Preloading and Surcharging* – One of the most effective methods for controlling the magnitude and rate of settlement in soils is to use preloads and surcharges. As a designer considering this type of mitigation, it should be noted that overall stability of the proposed fill heights also needs to be considered to ensure appropriate factors of safety are achieved under these conditions. Overall stability of fills is discussed in Section [9.3.7.3](#).

Preloading refers to the placement of the embankment fill early enough during construction that most of the settlement has occurred by the time the roadway is paved. Surcharging involves placing additional embankment height for some specified period of time, then removing the extra embankment fill once the anticipated settlement has occurred. This method is effective in speeding up the consolidation process because the percentage of consolidation required under a surcharge will be less than the complete consolidation under the design load. It is customary to assume consolidation is essentially complete at the theoretical 90 percent completion stage, where  $T = 0.848$ .  $T$  is known as a dimensionless time factor and is related to the coefficient of consolidation. In comparison,  $T = 0.197$  for 50 percent consolidation. Therefore, it takes less than one-fourth the time to achieve an average of 50 percent consolidation in a soil layer than it does to achieve 90 percent. In this example, the objective would be to place a surcharge sufficiently large such that 50 percent of the total settlement estimated from the fill embankment and the surcharge is equal to or greater than 100 percent of the settlement estimated under the fill embankment alone at its design height. The surcharge fill as a stand-alone method to accelerate the rate of settlement needs to be at least one-third the design height of the embankment to provide any significant time savings. It should be noted that using wick drains as discussed in the next subsection may reduce this required height and still achieve the same result.

In addition to decreasing the time to reach the target settlement, surcharges can also be used to reduce the impact of secondary settlement. Similar to the example presented above, the intent is to use the surcharge to pre-induce the settlement estimated to occur from primary consolidation and secondary compression due to the embankment load. For example, if the estimated primary consolidation under an embankment is 18 inches and secondary compression is estimated at an additional 6 inches over the next 30 years, then the surcharge would be designed to achieve 24 inches of settlement

or greater under primary consolidation only. The principles of the design of surcharges to mitigate long-term settlement are complex and the Geotechnical Services Section should be contacted if this method is being proposed on a project.

Two significant design and construction considerations for using surcharges include embankment stability and reuse of the additional fill materials. New fill embankments over soft soils can result in stability problems as discussed in Section [9.3.7.3](#). Adding additional surcharge fill would only exacerbate the stability problem. Furthermore, after the settlement objectives have been met, the surcharge will need to be removed. If the surcharge material cannot be moved to another part of the project for use as fill or as another surcharge, it is often uneconomical to bring the extra surcharge fill to the project only to haul it away again. Also, when fill soils must be handled multiple times or during cold winter months, it is advantageous to specify granular material to reduce workability issues during wet and freezing weather conditions.

*Wick Drains* – Wick drains, or prefabricated vertical drains, are vertical drainage paths that can be installed into compressible soils to decrease the overall time required for completion of primary consolidation. Wick drains typically consist of a long plastic core wrapped by a geotextile. The geotextile functions as a separator and a filter to keep the plastic core from being plugged by the adjacent soil, and the plastic core provides a means for the excess pore water pressures to dissipate. A drainage layer is typically placed across the ground surface prior to installing the wick drains and provides a drainage path beneath the embankment for water flowing from the wick drains. A drainage layer typically consists of a free draining material such as an MDOT Class IIAA or 6A.

The drains are typically rectangular measuring approximately 4 inches wide by 3/16 inch thick and have a length as specified on the plans. They are attached to a mandrel and are usually pushed into place using a static force. After the wick drains are installed, the fill embankment and possibly surcharge fill are placed above the drainage blanket. A key consideration for the use of wick drains is the site conditions. If obstructions or a very dense or stiff soil layer is located above the compressible layer, predrilling may be necessary, which may offset the economic viability of this option. The use of wick drains to depths over 80 feet also require specialized equipment.

The primary function of a wick drain is to reduce the drainage path in a thick compressible soil deposit. A significant factor controlling the time rate of settlement is the length of the drainage path. Since the time required for a given percentage consolidation completion is related to the square of the drainage path, cutting the drainage path in half would reduce the consolidation time to one-fourth the initial time, all other parameters held constant. A key design consideration is maximizing the

efficiency of the drain spacing. For design guidance, refer to FHWA RD-86, Prefabricated Vertical Drains.

*Lightweight Fill* – Lightweight fills can also be used to mitigate settlement issues by reducing the new loads imposed on the underlying compressible soils, thereby reducing the magnitude of the settlement. Situations where lightweight fill may be appropriate include conditions where the construction schedule does not allow for time of staged embankment construction, where existing utilities or adjacent structures are present that cannot tolerate the magnitude of settlement induced by placement of typical fill, and at locations where post-construction settlements may be excessive under conventional fills.

Lightweight fill can consist of a variety of materials including expanded polystyrene blocks (geofoam), lightweight cellular concrete, or lightweight aggregates (expanded shale, blast furnace slag). Lightweight fills typically have much higher unit prices compared to conventional earth fill but are especially effective in mitigating settlement and global stability issues.

Geofoam is approximately 2 pounds per cubic foot (pcf) and, as a result, is particularly effective at reducing driving forces or settlement potential. The weight is proportional to the Young's Modulus, or compressibility, of the foam and inversely proportional to its unit cost. The specific grade of foam selected should consider the needs of the project. Typical geofoam embankments consist of the foundation soils, the geofoam fill, and a load dissipater slab designed to transfer loads to the geofoam. Geofoam can be severely damaged by gasoline and petroleum-based products and, therefore, must be covered with an impermeable liner where such fluids can potentially reach the geofoam. Other design considerations for geofoam include creep, flammability, buoyancy, moisture absorption, photo-degradation, and differential icing of pavement constructed over geofoam. Furthermore, geofoam should not be used where the water table could rise and cause buoyancy problems because geofoam will float. Design guidelines for geofoam embankments are provided in the National Cooperative Highway Research Program (NCHRP) document titled *Geofoam Applications in the Design and Construction of Highway Embankments* (Stark et al., 2004). Geofoam embankments using vertical side slopes, or side slopes steeper than 1V:2H, and their associated facing treatments are not permitted unless approved in writing by the Geotechnical Services Section. MDOT has developed a special provision for usage of geofoam in roadway and bridge approach applications. For use of geofoam beneath roadways, a minimum distance of 3.5 ft is required from the finish grade to the top of the geofoam. When geofoam is used next to slopes, a minimum cover of 2 ft is required from the finish grade to the outermost edge of the geofoam block. In addition, the maximum fill height placed above

the geofoam must be analyzed to ensure acceptable strength and deformation requirements.

Large quantities of air can be entrained into a cement and water mixture to produce a lightweight porous cementitious material that can be poured in place of soil to reduce the driving force to improve stability or reduce settlement. Typical unit weights range from 20 to 80 pcf and, relative to soil, its shear strength is fairly high. However, if significant differential settlement is still anticipated despite the use of the lightweight cellular concrete, due to its relatively brittle nature, it could crack and lose much of its shear strength. Therefore, the stability analysis must be analyzed using cracked section properties. This aspect should be considered if using lightweight cellular concrete. In addition, specifications typically require lift thicknesses that allow for dissipation of heat of hydration. Its cost can be quite high, being among the most expensive of the lightweight fill materials mentioned herein.

Mineral aggregates, such as expanded shales or blast furnace slags, can also be used as lightweight fill materials. Expanded shales consist of inert mineral aggregates that have similar shear strengths to many conventional fill materials but have in-place unit weights between 45 to 60 pcf. The primary disadvantage with expanded shales is that these materials are expensive. Blast furnace slag is a waste material sometimes used for lightweight fill. The weight of blast furnace slag is approximately 80 pcf and, as a result, is not as effective as other lightweight fill materials. Due to the potential durability and chemical issues associated with some lightweight aggregates, approval from the Geotechnical Services Section is required before such materials may be considered for use in embankments.

### 9.3.7.3 Slope Stability of Embankments and Slopes

The Geotechnical Engineer is responsible for determining the overall stability of natural slopes, cut slopes, and embankments for all phases of construction. Consider the factors in the following subsections when planning and performing a stability assessment. Moreover, any fill placed near or against a bridge abutment or foundation or that can impact a nearby buried or aboveground structure, will likewise require a stability assessment by the Geotechnical Engineer. Embankments and slopes less than 10 ft in height with 2H:1V or flatter side slopes may be designed based on past precedence, experience, and engineering judgement provided there are no problematic soil conditions.

#### 9.3.7.3.1 Development of Parameters for Stability Assessment

The stability analysis for a specific site should include the following general approach: *Soil Strength Parameters* - Perform and obtain appropriate level of investigation, sample collection, and testing to adequately analyze the slope for the appropriate conditions.

Section 6.3.2 provides field investigation guidance for roadway fill and slopes. In addition, detailed assessment of soil and rock stratigraphy is critical to the proper assessment of slope stability and is a direct input parameter for slope stability analysis. It is important to define any thin, weak layers that are present as they could control the stability of the slope in question. Knowledge of geologic conditions present at the site and knowledge of past performance may also be critical factors in the assessment of slope stability.

Determine whether the soil layers will experience long-term and/or short-term loading (drained vs. undrained) strength and which one will control the stability of the slope because it will determine the type of in-situ and lab testing performed for the site.

Table 14 summarizes the principles involved in selecting analysis conditions and shear strengths. For short-term stability analysis, undrained shear strength parameters should be obtained. For long-term stability analysis, drained shear strength parameters may be estimated, but project-specific testing may be required. When assessing the stability of a landslide, residual shear strength parameters may be needed, since the soil has typically deformed enough to reach a residual value. Additionally, if a cut slope in overconsolidated clay is exposed, then residual strength values may be the controlling case. Furthermore, if a staged stability analysis (multi-stage loading) is required due to a site underlain by silt, soft clay or organic soils, then appropriate strength parameters should be obtained under the anticipated staged loading conditions.

Table 14: Shear Strengths and Drainage Conditions for Slope Stability Analysis (after FHWA-NHI-05-123, 2005)

	CONDITION		
	Undrained/End of Construction	Intermediate/Multi-Stage Loading	Drained/Long-Term
Analysis procedure and shear strength for free draining soils	Effective stress analysis, using $c'$ and $\phi'$	Effective stress analysis, using $c'$ and $\phi'$	Effective stress analysis, using $c'$ and $\phi'$
Analysis procedure and shear strength for impermeable soils	Total stress analysis, using $c$ and $\phi$ from in-situ, UCT, UU or CU tests	Total stress analysis, using $c_u$ from CU tests and estimate of consolidation pressure	Effective stress analysis, using $c'$ and $\phi'$
Internal pore pressures	No internal pore pressure for total stress analyses, set $\mu$ equal to zero in computer input	No internal pore pressure for total stress analyses, set $\mu$ equal to zero in computer input	$\mu$ from seepage analyses
	$\mu$ from seepage analysis for effective stress analyses	$\mu$ from seepage analysis for effective stress analyses	

External water pressures	Include	Include	Include
Unit weight	Total	Total	Total*

$c', \phi'$  – drained strength parameters, effective cohesion and effective angle of friction  
 $c, \phi$  – undrained strength parameters, cohesion and angle of friction  
 $c_u$  – undrained shear strength  
 $\mu$  - pore pressure.  
 UCT – Unconfined Compression Test, UU – Unconsolidated Undrained, CU – Consolidated Undrained  
 \*This assumes the software or analysis method takes into account pore water pressures.  
 Note: Multi-stage loading includes stage construction, rapid drawdown, and any other condition where a period of consolidation under one set of loads is followed by a change in load under undrained conditions.

It is not always easy to determine whether soil will behave in a drained or undrained manner. Both the rate of loading and the permeability of the soil will determine whether the soil responds in a drained or undrained state. Because it is often very difficult to predict the rate of loading during design, the best approach is to check both the drained and undrained cases and to use the more critical strength as the basis for design.

*Groundwater* – Determine the groundwater level (piezometric levels) for normal and worse case conditions. For natural slopes, detailed piezometric data at multiple locations and depths within and below the slope will likely be needed, depending on the geologic complexity of the soil stratigraphy and groundwater conditions. Consider the potential for variations in groundwater levels, seasonal fluctuations, artesian effects, perched water, piping due to water exiting the slope face, potential for rapid drawdown, and the effects of irrigation.

*Cross-Sections* – Obtain cross-sections along the slope to determine site geometry in relation to vertical and lateral limits of each soil layer. Locate cross-sections in critical areas with respect to loading, height/inclination of slope, and adverse or weak subsurface conditions.

*External Loads* – Analyze the effect of structure loads, soil loads, and live load surcharges on slope stability.

*Construction* – Consider the construction schedule and any safety issues that may arise during construction. The most critical case may occur during construction of a structure, utility installation, embankment, or temporary cut. Foreseeing these conditions and analyzing them in the design stage may result in fewer issues during construction.

### 9.3.7.3.2 Stability Analysis Methods

Limit equilibrium methods must be used to assess slope stability. The Modified Bishop, simplified Janbu, Spencer, or other widely accepted slope stability analysis methods should be used for rotational, translational, and irregular surface mechanisms. For more detailed discussion on the use of these methods, refer to the *FHWA-NHI—05-123 Soil Slope and Embankment Design* publication. Section [2.3.1](#) of the Manual provides various computer software packages available that allow the limit equilibrium analysis to be performed relatively quickly.

In a purely cohesionless soil profile, the potential slope failure mechanism is anticipated to be relatively shallow and parallel to the slope face. For infinite slopes consisting of cohesionless soils that are above the water table, the factor of safety for slope stability is determined as follows:

$$\text{Factor of Safety} = \frac{\tan \phi}{\tan \beta} \quad \text{where } \phi \text{ is the internal angle of soil friction and } \beta \text{ is the slope angle.}$$

Note that conducting an infinite slope analysis does not preclude the need to check for deeper slope failure mechanisms, such as would be assessed by the Modified Bishop or similar methods listed above.

Translational (block) or noncircular searches are generally more appropriate for modeling thin, weak layers or suspected planes of weakness. If there is a disparately strong layer either below or above a thin, weak layer, the user must ensure that the modeled failure plane lies within the suspected weak layer so that the most critical failure surface is modeled as accurately as possible. Circular searches for these types of conditions should generally be avoided because they do not generally model the most critical failure surface.

### 9.3.7.3.3 Resistance Factors and Factors of Safety for Slope Stability Analysis

For overall stability analysis of walls and structure foundations, design must be consistent with the *AASHTO LRFD Bridge Design Specifications*. Unless approved by the Geotechnical Services Section (GSS), the following minimum resistance factors and factors of safety must be used in the design analysis. For slopes adjacent to but not directly supporting or containing a structural element, a maximum resistance factor of 0.75 should be used. For foundations on slopes that support or contain a structural element such as bridges, critical utility, building foundation, or another retaining wall, a maximum resistance factor of 0.65 should be used. Exceptions to this could include minor walls that have a minimal impact on the stability of the existing slope, in which the 0.75 resistance factor may be used. Since these resistance factors are combined with a load factor of 1.0 (overall stability is assessed as a service limit state only), these

resistance factors of 0.75 and 0.65 are equivalent to a factor of safety equal to 1.3 and 1.5, respectively. These factors of safety that are produced in available slope stability programs are essentially inverted to obtain the resistance factors noted above.

For general slope stability analysis of cuts, fills, and landslide repairs, a minimum factor of safety equal to 1.25 should be used. Larger factors of safety should be used if there is significant uncertainty in the slope analysis input parameters. The 1.25 factor of safety guideline used in cut and natural slope analysis assumes that in-situ and/or laboratory testing is performed to obtain additional soil strength parameters. Higher factors of safety should be considered by the Geotechnical Engineer if only N-value correlations are used to determine soil strength parameters.

#### 9.3.7.4 Lateral Squeeze

Lateral squeeze is a special case of short-term undrained deformation that occurs from a local shear or a long-term creep type deformation when an applied load bears on a weak cohesive layer overlying a stiff soil or rock stratum as illustrated in [Figure 17](#). This phenomenon can occur where a soft cohesive layer is located beneath an embankment fill or a bridge approach fill leading up to an abutment foundation. When this scenario occurs, significant lateral stresses and associated lateral deformations can occur and, therefore, must be analyzed by the Geotechnical Engineer. This check is in addition to the overall stability analysis performed in the AASHTO code.

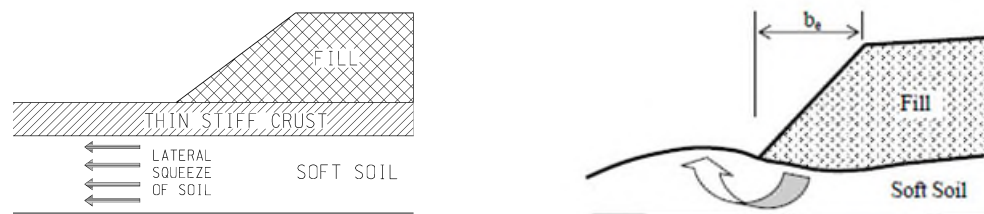

Figure 17: Schematics of Lateral Squeeze Phenomenon

For embankment slopes which may encounter this scenario, the following equation can be used to determine the factor of safety against failure by squeezing. The geometry of the problem and the forces involved are shown in [Figure 18](#).

$$FS_{SQ} = \left[ \frac{2s_u}{\gamma D_s \tan \theta} \right] + \left[ \frac{4.14s_u}{\gamma H} \right]$$

$\theta$  = angle of slope

$\gamma$  = unit weight of the fill

$D_s$  = depth of soft soil beneath the toe of the end of slope or side slope of the fill

$H$  = height of the fill

$s_u$  = undrained shear strength of the soft soil beneath the fill

$FS_{SQ}$  = Lateral Squeeze Factor of Safety

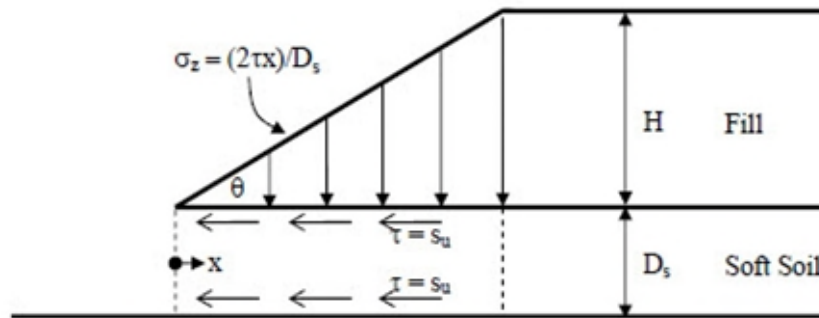

Figure 18: Definitions of Parameters in Calculating Factor of Safety Against Lateral Squeeze

For  $FS_{SQ}$  less than 2.0, lateral squeeze may occur, and remediation options must be considered. Contact the GSS to discuss potential options. The lateral squeeze analysis is especially crucial when considering the use of a reinforced slope or base reinforcement in improving stability of fill embankments over softer soils. When the depth of the soft layer,  $D_s$ , is greater than the base of the width of the end slope,  $b_e = H/\tan\theta$ , general slope stability behavior governs the design. In that case, the methods described in previous sections may be used to evaluate the overall stability of the embankment. If adequate support conditions cannot be achieved, either the soft soils should be removed, or ground improvement methods of the foundation soils is required. Additional discussion on these methods are discussed in [Section 9.3.7.6](#).

For approach fills placed at bridge approaches, experience has shown that lateral squeeze of the foundation soil can occur, and abutment tilting may result if the surface load applied by the weight of the fill exceeds 3 times the undrained shear strength,  $s_u$ , of the soft foundation soil,

$$\gamma * H > 3 * s_u,$$

where  $\gamma$  is the unit weight of fill and  $H$  is the height of the fill. [Figure 19](#) illustrates different modes of abutment tilting due to lateral squeeze. Whether the lateral squeeze will be short- or long-term can be determined by evaluating the consolidation rate of settlement with respect to the rate of application of the load.

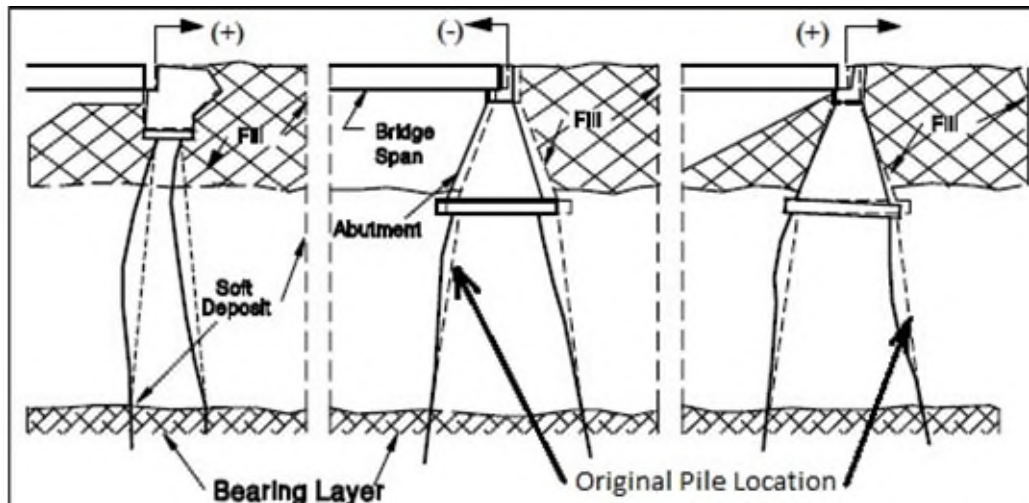

Figure 19: Examples of Abutment Tilting Due to Lateral Squeeze (FHWA, 2006a)

If lateral squeeze is suspected at a bridge abutment (based on the aforementioned equation), then a recommended solution to minimize abutment tilting is to induce settlement of the fill prior to installation of abutment piles or shafts. Methods of doing this are discussed in Section [9.3.7.2.3](#). If the construction time schedule or other factors do not permit preconsolidation of the foundation soils, then lightweight fill can be used to reduce the driving forces.

#### 9.3.7.5 Other Slope Stability Considerations

Over the years of embankment and cut slope construction, MDOT has experienced occasional stability issues with existing embankments and cut slopes. Usually, the stability problem is rooted in some form of drainage issue or underlying problematic soil condition. One area where stability issues have arisen is where embankments are widened and/or constructed over peat excavation and swamp backfill areas. In this scenario, either the peat soils were not completely removed or the embankment height in conjunction with horizontal/vertical excavation limits were not sufficient. Additional detail on scenarios where additional stability analysis may be required in peat excavation areas are discussed in Section [9.3.3.2.2](#).

Another potential long-term, problematic scenario that arises is where embankment fills greater than 30 ft high are constructed at a 1V:2H slope. In this situation, two problematic conditions, surficial erosion/sloughing and long-term creep of the embankment side slope, have been observed. Dealing with the initial problem can be handled by specifying appropriate erosion control measures in the design. Additionally, including subbase underdrains and subgrade underdrains into the design allows for capture of any subsurface water and prevents saturation of the embankment fill or water daylighting onto the slope. Long-term creep of the embankment is usually quite massive and can produce constant or seasonal movement, which can lead to

rideability/safety issues or eventual roadway failure. As a result, the Geotechnical Engineer should look at embankments with these fill heights during design, especially if typical embankment construction in the region of the state consists of clay fill, and determine if mitigation is required. Possible mitigation measures could be flattening the slope, implementing a bench in the slope, or specifying a granular embankment. If issues such as these are anticipated by the Geotechnical Engineer or scoping engineer, appropriate discussions should occur with the designer early in the design or scoping phase so that appropriate right-of-way limits (if applicable) can be defined and planned for in a timely manner.

#### **9.3.7.6 Stability Improvement Techniques**

If the results of the stability analyses indicate that the slope does not meet the minimum factor of safety requirements, then it may be necessary to incorporate slope stabilization methods to improve the slope performance. This section provides a summary of stabilization methods to consider for natural or cut slopes in soil and embankment fills. For rock slope stability issues, contact the GSS. In addition, [www.geotechtools.org](http://www.geotechtools.org) may also provide some insight into potential mitigation measures to improve embankment stability.

##### **9.3.7.6.1 Regrading – Flattening the Slope**

The simplest approach for improving the stability of a slope is to flatten the slope angle until the stability requirements are met. This approach can often be used for either cut slopes or fill slopes unless right-of-way constraints, environmental limitations, or economic considerations preclude regrading. In some locations, the stability of a slope can be improved by constructing a balance berm at the toe of the slope. The berm functions by providing additional horizontal resistance to the driving force. While the balance berm can be used for cut slopes, it is more suitable for use with embankment fills. In addition, regrading by reducing the fill height could be a remedial option if other design parameters, such as geometrics or low beam elevations on a river crossing, are still able to be achieved.

##### **9.3.7.6.2 Direct Excavation and Replacement**

Another relatively simple stability measure is to remove and replace problematic soil, if it is determined to be too soft for the proposed embankment loading. This approach is normally limited to a depth of 10 ft below the existing grade. Ideally, this option is used when the soil is above the water table or possible dewatering provisions must be accounted for, consequently increasing the cost of this option. Replacement soil is typically engineered granular backfill.

##### **9.3.7.6.3 Staged Construction**

Where soft compressible soils are present below a new embankment location and it is not economical to remove and replace these soils with compacted fill, the embankment

can be constructed in stages to allow the strength of the compressible soils to increase under the weight of new fill. Construction of the second and subsequent stages commences when the strength of the compressible soils is sufficient to maintain stability. To define the allowable height of fill for each stage and maximum rate of construction, detailed geotechnical analysis is required. The analysis to define the height of fill placed during each stage and the rate at which the fill is placed is typically completed using a limit equilibrium slope stability program along with time rate of settlement analysis to estimate the percent consolidation required for stability. Field monitoring of settlement and pore water pressures are usually required during construction.

#### 9.3.7.6.4 Reinforced Soil Slope

Reinforcement may be used to increase the factor of safety against slope failure and typically consists of placing either a geotextile or geogrid at the base of an embankment prior to constructing the embankment. This approach is particularly effective where soft/weak soils are present below a planned embankment location. The reinforcement can be designed for either temporary or permanent applications. The design of the reinforcement is similar to the design of a reinforced slope in that limit equilibrium slope stability methods are used to determine the geotextile strength required to obtain the desired factor of safety. Depending on the strength of reinforcement required in the design, procurement of higher strength geotextiles can take “considerable” time once the project is let. As a result, the Geotechnical Engineer will need to assess this parameter and compare it to the project construction timeline during the design phase to minimize the potential of construction delays occurring.

Reinforcement materials should be placed in continuous, horizontal strips with the direction of main reinforcement placed perpendicular to the slope face. Where base reinforcement is used, the use of Granular Material Class II or dense graded aggregate 21AA or 22A may also be needed to increase the embankment shear strength.

Depending on the height of the slope and right-of-way limitations, reinforced soil slopes may be used to achieve suitable factors of safety for stability. Reinforced slopes and embankments are slopes constructed at steeper face angles than the effective friction angle of the fill by the inclusion of soil reinforcement. The reinforcement typically consists of either geotextile or geogrid and is placed in alternating, horizontal layers with the backfill. For detailed discussion and design guidance, refer to the FHWA-NHI-00-043 *Mechanically Stabilized Earth Walls and Reinforced Soil Slopes Design and Construction Guidelines* manual.

#### 9.3.7.6.5 Lightweight Fills

Lightweight fills reduce the proposed loads imposed on the underlying soil, thereby reducing the driving force and increasing the stability of an embankment. Materials classified as lightweight fill consist of expanded polystyrene blocks (geofoam), lightweight cellular concrete, or lightweight aggregates (expanded shale, blast furnace slag). This remedial option may be appropriate on projects where the construction schedule does not allow for use of other less timely options. Further discussion on this topic is provided in Section [9.3.7.2.3](#).

#### 9.3.7.6.6 Ground Improvement

Various types of ground improvement can be considered to improve the stability or reduce the settlement of a project site. Typically, these methods involve replacing or improving the existing material within the slide plane with a higher friction or cemented soil. Selecting an appropriate ground improvement method depends on the evaluation of several factors including the types of soil at the site, the depth of the critical failure zone, access requirements, project timeline, surrounding infrastructure, and design objectives. Potential ground improvement methods suitable for highway use include the following.

*Stone Columns* – This method involves placing columns of gravel or crushed rock in the ground at 5 to 10 ft horizontal spacing. In general, the columns range in diameter and depth from 15 to 36 inches and 10 to 50 ft, respectively. Increased strength within the treatment zone results in a higher factor safety for embankment or slope stability. Additionally, properly designed treatment zones beneath a proposed embankment result in limiting the amount of settlement. For design methods and additional considerations, refer to the FHWA-RD-98-086 Ground Improvement Technical Summaries and FHWA-RD-83-02C *Design and Construction of Stone Columns*.

*Vibro-Densification/Compaction* – This method involves densification of cohesionless soils with a vibrating probe. Horizontal spacing of densification points typically range from 5 to 10 ft, depending on the density of the existing material. The required treatment depth is designed for each project and is typically in the range of 15 to 50 feet. This method is most suitable in cohesionless soils that have less than 15 percent fines (passing the #200 sieve). Densification can be done above and below the groundwater table. Further discussion and design guidance can be found in FHWA-SA-98-086 *Ground Improvement Technical Summaries*.

*Dynamic Compaction* – This method involves dropping a 10 to 20-ton weight from heights ranging from 40 to 70 ft above the ground surface. This method is suitable for densifying cohesionless soil located above the groundwater level. Depths of densification can extend to about 30 ft below the treatment surface. The primary

advantage of this approach is the relatively low cost for the improvement. One disadvantage is the ground vibration that occurs during each drop weight. Additional design guidance can be found in the FHWA-SA-95-037 *Dynamic Compaction* manual.

*Other Methods* – Other ground improvement methods exist that may be viable in the transportation infrastructure. These include compaction grouting and jet grouting/cement deep soil mixing. Compaction grouting is where a column of grout is formed at a specified spacing by injecting grout at a high pressure. Where limited headroom exists on projects, this may be a viable ground improvement option. Jet grouting involves mixing cement with the native soil thereby increasing the strength of the soil. While this is a very versatile ground improvement method, it is usually the most expensive.

#### 9.3.7.6.7 Structural Systems

Structural systems can be used to enhance the stability of many cut or natural slopes. These structural systems are often more expensive than methods involving ground improvement, regrading, and groundwater control. Possible systems include the following.

*Retaining Walls* – In many cut or natural slope locations, retaining walls can be used to improve local and/or deep-seated stability. These include conventional concrete gravity and cantilever retaining walls and cantilever or anchored soldier pile walls. Section [9.6](#) discusses types of retaining walls in more detail.

*Ground Anchor or Soil Nail Systems* – Methods of stabilizing existing slopes may consist of ground anchors or soil nails. Ground anchors consist of strands or bars that are grouted into the soil or rock at some distance from the slope face and then post-tensioned. Soil nails are reinforcing, passive elements that are drilled and grouted sub horizontally in the ground to support excavations in soil or in soft and weathered rock. For additional guidance on the design and construction of these systems, refer to the AASHTO *LRFD Bridge Design Specifications* manual, FHWA-IF-99-015 *Ground Anchors and Anchored Systems* manual, and the FHWA-NHI-14-007 *Soil Nail Walls Reference Manual*.

#### 9.3.7.6.8 Rock Buttress or Berm

The principle behind the use of buttresses and toe berms is to provide sufficient dead weight and increased shear resistance near the toe of the unstable slope or embankment to increase the stability to an acceptable level. Two types of rock buttresses or berms are illustrated in [Figure 20](#) and [Figure 21](#). In addition, the geotextile fabric and open graded nature of the stone berm provide a seepage path for any water that exits the unstable slope or embankment. The buttress must be heavy enough to

provide the additional resistance near the toe of the slope required for the stability. In some cases, the rock buttress can extend below the toe of slope and create a shear key mechanism that provides increased soil strength and achieve better factors of safety for deeper seated failure surfaces.

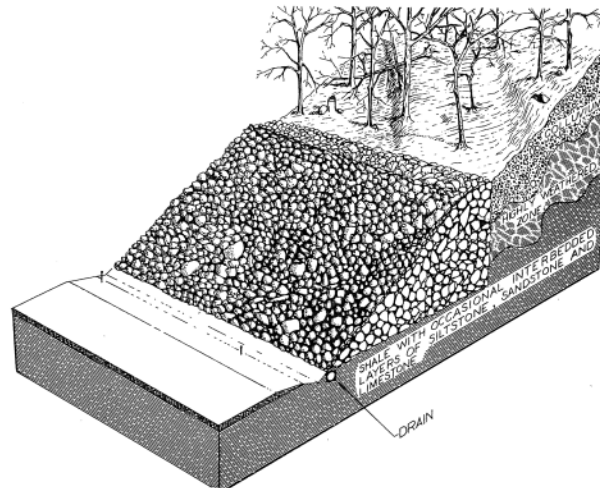

Figure 20: Rock Buttress Integrated into Slope Fix (TRB SR 247, 1996)

The buttress must be stable against overturning, sliding, and bearing failure. A settlement analysis should also be performed if the foundation is compressible to ensure that the final grade of the buttress is consistent with the geometric design requirements of the project. Internal failure modes of the buttress should also be checked to ensure that the buttress does not fail by internal shear.

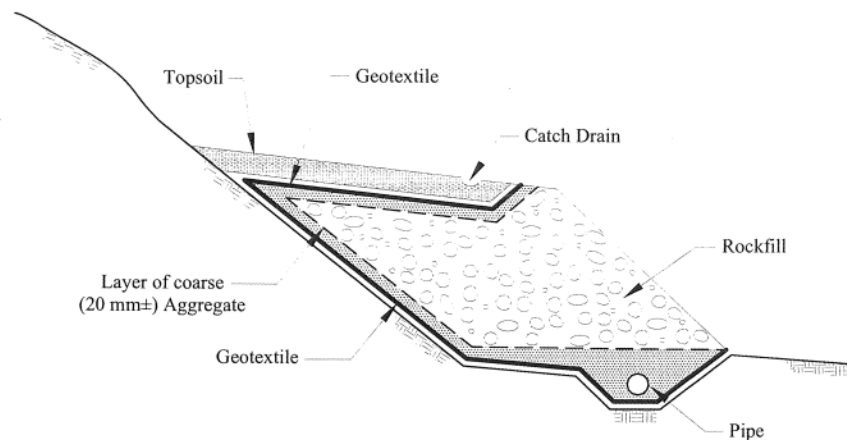

Figure 21: Rock Buttress at Toe of Slope (FHWA, 2005)

#### 9.3.7.6.9 Groundwater Control

Groundwater can be a significant contribution to slope instability, primarily from the reduction in effective stresses. The importance of adequate drainage cannot be overstated when designing cut slopes. Surface water collection can be accomplished

using drainage ditches and berms located above the top of the cut, around the sides of the cut, and at the base of the cut. Once the surface water is collected, it must be directed into suitable collection facilities.

One situation that is often overlooked in design of cut slopes is where the existing slope continues upward at the top of the cut. Surface water flowing from the upper natural slope onto the cut section can cause severe erosion and sloughing of the cut slope. A common remedy is to include a cobblestone ditch at this interface point (see [Figure 22](#)). The ditch collects the surface water and directs it to a suitable collection area. The Geotechnical Engineer is responsible for ensuring that pay items to address this scenario are included on the plans.

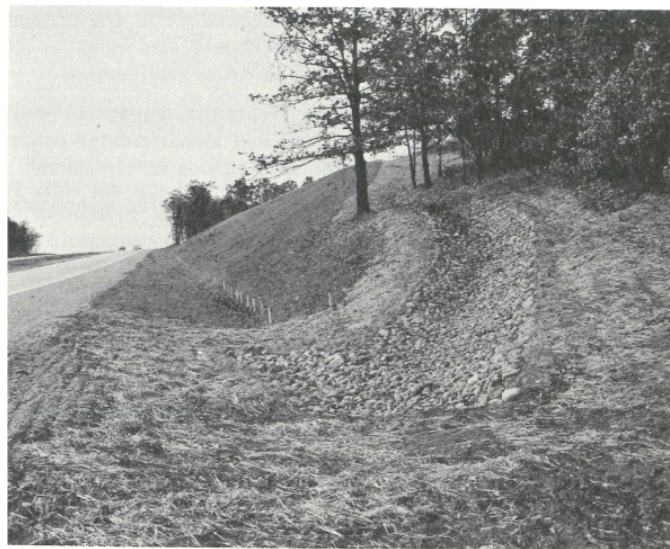

Figure 22: Cobblestone Ditch at Slope Interface

Another situation that arises in the construction of cut slopes is where the cut slope intersects either the actual groundwater table or a perched groundwater condition. Borings taken across the cut section should provide information on the groundwater situation and the Geotechnical Engineer can then provide appropriate recommendations regarding profile grade, cut slope grades, and drainage. Common drainage recommendations in this situation include placing miscellaneous quantities of Bank Drains and/or Granular Blanket in the contract documents for use during construction. In areas that have known water issues, appropriate quantities can be placed on the specific plan sheets. In some cases where actual slope stability is dependent on keeping groundwater levels at a certain level, an actual bank drain design including details may be necessary so that assumptions utilized in the design analysis are then built in construction. [Standard Plan R-80 series](#) provides drainage details for Bank Drains and Granular Blankets. Section [9.3.4](#) also provides additional discussion on the use of these items.

Other drainage features such as horizontal drains and relief wells can also be used to lower groundwater levels when a stability problem arises. However, these are not widely used within MDOT, and if being considered on a project, the GSS should be contacted prior to their use.

### 9.3.8 EROSION CONTROL CONSIDERATIONS

Erosion control of embankment and cut slopes need to be considered as part of the design analysis. Surface erosion is most common in clean sands and nonplastic silts. All slopes should be designed with adequate drainage and temporary and permanent erosion control measures to limit erosion. The amount of erosion that occurs along the slope is a factor of soil type, rainfall intensity, slope angle, length of slope, slope geometry (i.e., swales, benches, curves), curb and gutter, and vegetative cover. While some of these factors are not controlled by the designer, the factors that are can be optimized to fit the site by the design team. Considerations and application for erosion control measures are in Section 2.05 of the *Road Design Manual* and Section 6 of the *Soil Erosion and Sedimentation Control Manual*.

### 9.3.9 DETERMINATION OF PLAN QUANTITIES AND CONTRACT DOCUMENTS

Section [9.3](#) covers considerable amounts of information regarding roadway design for MDOT. Throughout the roadway design process, it is important for the Geotechnical Engineer to communicate the necessary pay items, quantities, and special provisions required for design, bidding, and construction. For instance, quantities due to poor subgrade and/or drainage concerns must have appropriate pay items and quantities noted in the plans. Additionally, settlement and stability mitigation measures are unique items and require development of new special provisions or modification of existing ones specific for that job.

## 9.4 BRIDGE FOUNDATION DESIGN – LOAD AND RESISTANCE FACTOR DESIGN (LRFD) METHODOLOGY

The satisfactory performance of a structure depends on the proper selection, design, and construction of the foundation used to support the structure. This section discusses MDOT's criteria for the geotechnical design of bridge foundations for new structures. Section [9.5](#) provides foundation design criteria for allowable stress design (ASD) foundation design. These criteria for new bridges adhere to methods and policy set forth in the following documents unless otherwise modified herein.

- Section 3 (Loads and Load Factors) and Section 10 (Foundations) of the *AASHTO LRFD Bridge Design Specifications* (most recent version)
- Program/Project Management System (P/PMS) Tasks 3325, 3530, and 3815
- MDOT Bridge Design Manual
- MDOT Drainage Manual

The function of the bridge foundation is to transfer loads from the structure to the earth. This is done by spreading concentrated loads over a sufficient area to provide adequate bearing support and to limit deformations under the imposed load. The foundation can also transfer loads through unsuitable soil strata to suitable bearing strata. To successfully perform this task, knowledge of the loading conditions, environmental and climatic effects over the life of the structure, subsurface soil conditions, location and quality of rock, groundwater conditions, construction practices, scour effects on the structure, and construction cost is necessary to choose the most appropriate foundation type and size.

On some projects, the selection process will be relatively intuitive for the particular geology and bridge location. However, other times secondary factors such as maintaining traffic or construction schedule may be a deciding factor during the foundation selection process. It should be noted that the selection process involves several parties, especially on more complex projects, and continued communication during the design development is crucial and highly encouraged as part of the MDOT foundation design process.

#### 9.4.1 DESIGN METHODOLOGY OVERVIEW

The former process for designing foundations used the Allowable Stress Design (ASD) methodology in accordance with the *2002 AASHTO Standard Specifications for Highway Bridges, 17<sup>th</sup> Edition*. Existing bridges considered for superstructure replacement or widening should continue to use the ASD foundation design methods or as directed by MDOT Bridge Design. In these scenarios, it is imperative that the geotechnical and structural engineers discuss this early in the project so that the design approach is consistent.

In 2007, MDOT adopted the *AASHTO LRFD Bridge Design Specifications*, and the approach used for the design of new bridge supported foundation elements changed. The design methodology uses load and resistance factors based on the variability of loads and resistances. These load and resistance factors have been calibrated from actual statistics (in most cases) to ensure the reliability of components throughout the structure. In general, the overall concept in respect to structural and geotechnical engineering is that, when a certain load  $Q$  is placed on a component, there is sufficient resistance  $R$  to ensure that a certain performance criterion is not exceeded. This is illustrated in the following equation.

Load ( $Q$ ) < Resistance ( $R$ )

By adding load factors ( $\gamma$ ) and a load modifier ( $n$ ) to each type of load ( $Q$ ), a certain level of uncertainty, importance, and redundancy is applied to the anticipated loads. On the resistance side of the equation, a resistance factor ( $\phi$ ) is applied to the nominal resistance ( $R_n$ ) to account for variability and uncertainty. The following equation illustrates the basic LRFD design concept.

$$Q = \sum \eta_i \gamma_i Q_i \leq \phi R_n = R_r$$

Where,

$Q$  = Factored Load

$Q_i$  = Force Effect

$\eta_i$  = Load Modifier

$\gamma_i$  = Load Factor

$R_f$  = Factored Resistance

$R_n$  = Nominal Resistance (i.e., ultimate capacity)

$\phi$  = Resistance Factor

The above equation is applicable to more than one load condition that defines the “Limit State.” A Limit State is a condition beyond which a component/member of a foundation or other structure ceases to satisfy the provisions for which the component/member was designed. AASHTO has defined the following limit states for use in design:

- Strength Limit State
- Service Limit State
- Extreme Event Limit State
- Fatigue Limit State

The Fatigue Limit State is the only state that is not used in geotechnical analyses or design. A description of the limit states that are used in geotechnical engineering are provided in the following table.

Table 15: Limit States (modified after FHWA-NHI-05-094)

Limit State	Description
Strength	The strength limit state is a design boundary condition considered to ensure that strength and stability are provided to resist specified load combinations and avoid the total or partial collapse of the structure. Examples of strength limit states in geotechnical engineering include bearing failure, sliding, design flood event, and earth loadings for structural analysis. For the design flood event, MDOT uses the 100-year flood event.
Service	The service limit state represents a design boundary condition for structure performance under intended service loads and accounts for some acceptable measure of structure movement throughout the structure’s performance life. Examples include vertical settlement of a foundation or lateral displacement of a retaining wall. Another example of a service limit state condition is the rotation of a rocker bearing on an abutment caused by instability of the earth slope that supports the abutment.
Extreme Event	Evaluation of a structural member/component at the extreme event limit state considers a loading combination that represents an excessive or infrequent design boundary condition. Such conditions may include ship

Limit State	Description
	impacts, vehicle impact, ice flow, check flood, and seismic events. Because the probability of these events occurring during the life of the structure is relatively small, a smaller margin of safety is appropriate when evaluating this limit state. A common Extreme Limit State checked at MDOT is the check flood event (500-year flood event). Seismic events are not a normal Extreme Limit design check at MDOT.

#### 9.4.2 FOUNDATION LOAD AND RESISTANCE DETERMINATION

Bridge foundation loads are to be determined by the bridge engineer. However, the Geotechnical Engineer plays a key role in the evaluation of certain loads. The following discussion summarizes the typical process recommended in defining foundation loads.

- The bridge engineer determines the nominal loads for the structure, as well as the load combination limit states and load factors to be considered for each limit state. For lateral loading on a deep foundation system, the bridge engineer will identify the range of lateral loads and the fixity at the head of the pile. Some “back and forth” discussion with the Geotechnical Engineer may be prudent to obtain preliminary values of lateral resistance available based on the soil encountered at the site. For extreme events (e.g., ice, scour), the corresponding axial and lateral loads and their limit states should be identified as appropriate.
- The Geotechnical Engineer determines the geotechnical resistance based on the structure layout, load combinations provided by the bridge engineer, and data collected during the field and laboratory investigation. Again, some “back and forth” discussion may be necessary to determine the most suitable foundation support for the site.
- The bridge engineer then performs the final sizing and structural design of the foundations for the bridge based on input from the Geotechnical Engineer. If foundation elements are revised after submittal of the final geotechnical recommendations, then the Geotechnical Engineer should be contacted to determine if revisions are necessary.

#### 9.4.3 FOUNDATION TYPE

Foundations for MDOT bridge structures or federal and/or state funded structures must be supported by spread footings, driven piles, micropiles, or drilled shafts, unless otherwise approved by the GSS. Each of these foundation elements are discussed in the following sections.

##### 9.4.3.1 Shallow Foundations

Geotechnical design of footings, and all related considerations, must adhere to the *AASHTO LRFD Bridge Design Specifications*, Article 10.6, except as specified in the following paragraphs and sections. [Figure 23](#) provides a flowchart that illustrates the

design process and interaction required between structural and geotechnical engineers needed to complete a spread footing design.

In general, spread footings distribute the structure loads to suitable soil strata or rock at relatively shallow depth (typically less than 10 ft). Shallow foundations should not be utilized in the following situations:

- For piers at water (stream, river, drain) crossings where the proposed foundation would bear on soil or erodible bedrock,
- For abutments that bear on erodible rock, unless the bottom of footing is below scour depths determined for the check flood event. Spread footings on scour-resistant rock must be designed and constructed to maintain the integrity of the supporting rock,
- For abutments that bear on soil, unless approved by the GSS and the bottom of footing is below scour depths determined for the check flood event. In most cases, this will result in a deep foundation system,
- On nonengineered fills, and
- At abutments that are located within a Mechanically Stabilized Earth (MSE) wall unless the criteria in Section 7.03.12.C.2 of the *Bridge Design Manual* is met.

#### 9.4.3.1.1 Footing Bearing Depth

The bottom of footing will be mainly dictated by frost depth for footings not bearing on bedrock. In addition, footing depth may be dictated by scour depth or the depth to competent bearing stratum. Embedding the footing to an acceptable depth is imperative so that the footing does not move due to the freezing ground and subsequent expansion of the soil beneath the footing. For MDOT design, a minimum depth of 4 ft is required for footing embedment. This minimum depth is measured from the bottom of footing to finish grade. Since frost is multi-directional, this minimum dimension should be considered from any direction. In areas of the state where frost depths can go much deeper than 4 ft and high frost susceptible soils exist (see [Table 13](#)), the Geotechnical Engineer may specify additional footing depth requirements. In addition, footing depth may be dictated by scour depth or the depth to competent bearing stratum.

#### 9.4.3.1.2 Nearby Structures

Where foundations are placed adjacent to existing structures, the influence of the existing structure on the behavior of the foundation and the effect of the foundation on the existing structures shall be investigated. Issues to be investigated include, but are not limited to, settlement of the existing structure due to the stress increase caused by the new footing, decreased overall stability due to the additional load created by the

new footing, and the effect on the existing structure of excavation, shoring, and/or dewatering to construct the new foundation.

#### 9.4.3.1.3 Settlement Criteria of Shallow Foundations

Settlement normally governs the size and capacity for shallow foundations, especially in non-cohesive soils. The total and differential settlement of a substructure unit, as well as the differential settlement between two adjacent substructure units, must be considered when analyzing a shallow foundation. MDOT recommends a total settlement limit of 1.5 inches for an individual substructure unit and differential settlement of 0.75 inches between or within substructures units. This settlement criteria are the same for design of concrete culverts and 3-sided precast culverts. For flexible culverts, MDOT recommends a total settlement limit of 2 inches and differential settlement of 1.5 inches.

Furthermore, the time for settlement to occur, as well as the rate of settlement, should be considered in the analysis. The paragraphs below discuss how settlement and consolidation of the subsoils can be time dependent. In addition, longer spans or some type of extreme conditions may warrant consideration of settlement criteria outside these limits. Designers considering using criteria outside the aforementioned limits must ensure the structure can tolerate the settlement **and** receive approval from the GSS and MDOT bridge design supervising engineer.

Typically for shallow foundations founded on cohesionless soil, a large portion of the settlement occurs quickly, often during construction. Therefore, it may be possible to manage the settlement by considering the construction sequence and critical structure connection timeline. The Geotechnical Engineer should investigate the construction sequence and work with the bridge engineer in determining foundation suitability, especially if at first glance the calculated settlement seems to be undesirable.

For cohesive soils, the amount of settlement can be quite large and take a long time to occur. Therefore, subsoils, which consolidate to the extent that exceed the criteria previously provided, must be modified to support the footing or an alternate deep foundation system must be used. Transient loads may be omitted from the settlement analyses on or in cohesive soil deposits that are subject to time dependent consolidation.

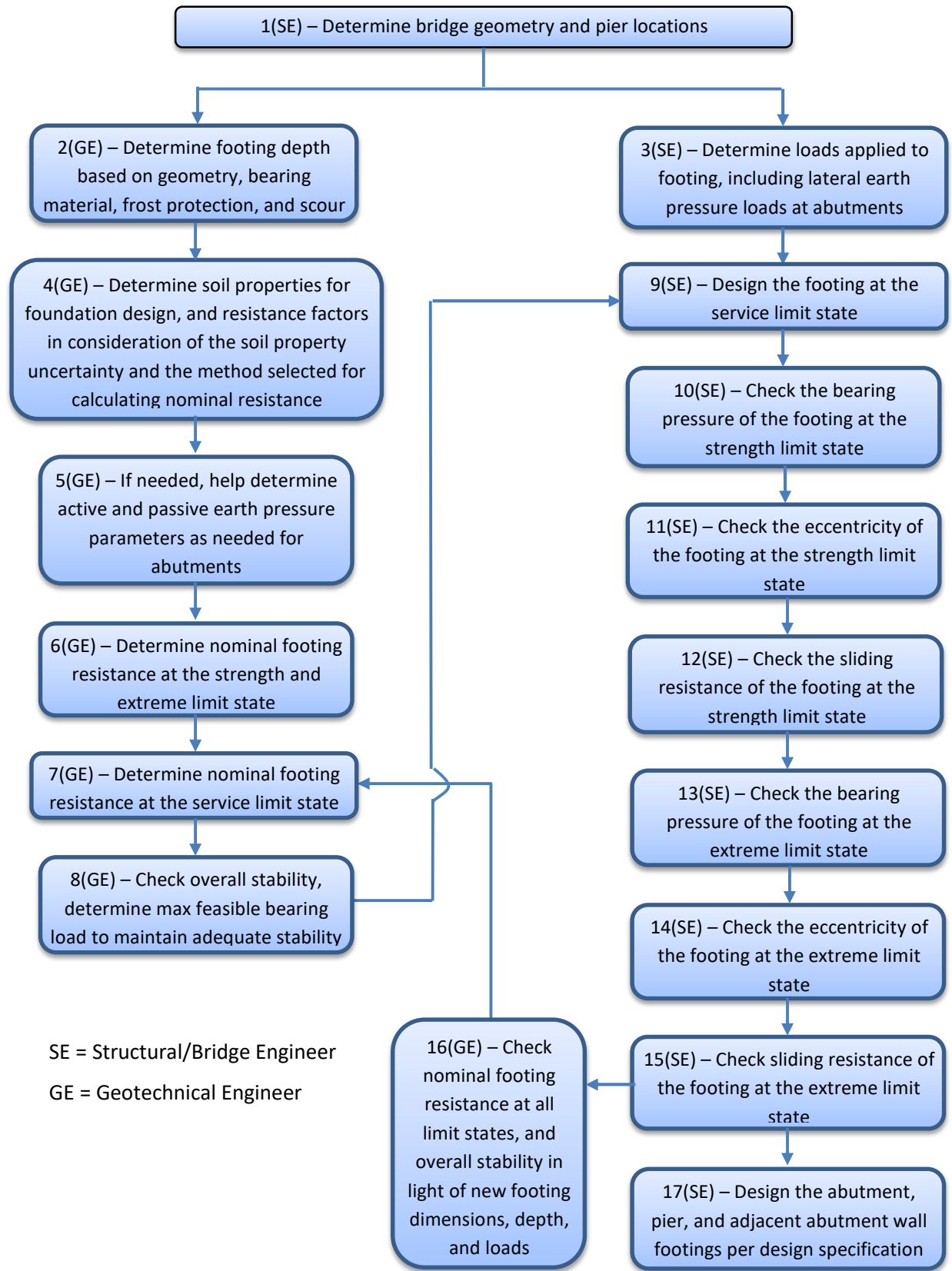

Figure 23: Flowchart for LRFD Spread Footing Design

#### 9.4.3.1.4 Other Shallow Foundation Considerations

MDOT has developed several bridge design guides for detailing spread footings located on Structure Embankment or in cut applications. Detail series [5.45](#) and [5.46](#) illustrate criteria when using a spread footing in these applications. The Geotechnical Engineer should ensure these guidelines are used when conducting the analysis and subsequently detailed appropriately on the final design plans.

#### 9.4.3.2 Driven Piles

The selection of driven pile foundation type for a structure should be based on the specific soil conditions, foundation loading requirements, and final performance criteria. Geotechnical analysis and design of driven piles must adhere to Section 10 of the *AASHTO LRFD Bridge Design Specifications* (most current version), except as specified herein and in the *MDOT Bridge Design Manual*. [Figure 24: General Flowchart for LRFD Pile/Shaft Design](#) provides a flowchart that illustrates the general design process and the interaction required between structural and geotechnical engineers to complete a driven pile foundation design. MDOT has standardized pile sizes and nominal resistances and therefore streamlining certain steps of this process.

##### 9.4.3.2.1 Pile Types, Sizes and Tip Reinforcement

Piles installed on MDOT projects or those with federal aid should consist of steel H-piles, steel cast-in-place (CIP) concrete piles, or timber piles. Standard practice is to utilize steel piles for structures supporting vehicular traffic while timber piles are typically utilized to support timber bridge structures on lower volume local roads, boardwalks, or multi-use recreational trail structures. Typical pile sizes are provided in Section [7.03.09.B](#) of the *MDOT Bridge Design Manual*. Timber pile size variations are provided in Section 912 of the *Standard Specifications for Construction*.

Unless otherwise required for special driving conditions, pipe piles should be analyzed with a closed end as a flat plate with or without a steel pile point (see *Bridge Design Guide* [8.21.03](#)). Reinforced pile tips may be warranted on H-piles where the piles are required to penetrate through cobbles and/or boulders or piles are driven to or into bedrock. However, installing a pile tip does not eliminate all potential for pile damage and high driving stresses may occur at these locations resulting in pile damage. To minimize the risk from this occurring, a drivability analysis must be included as part of the design process.

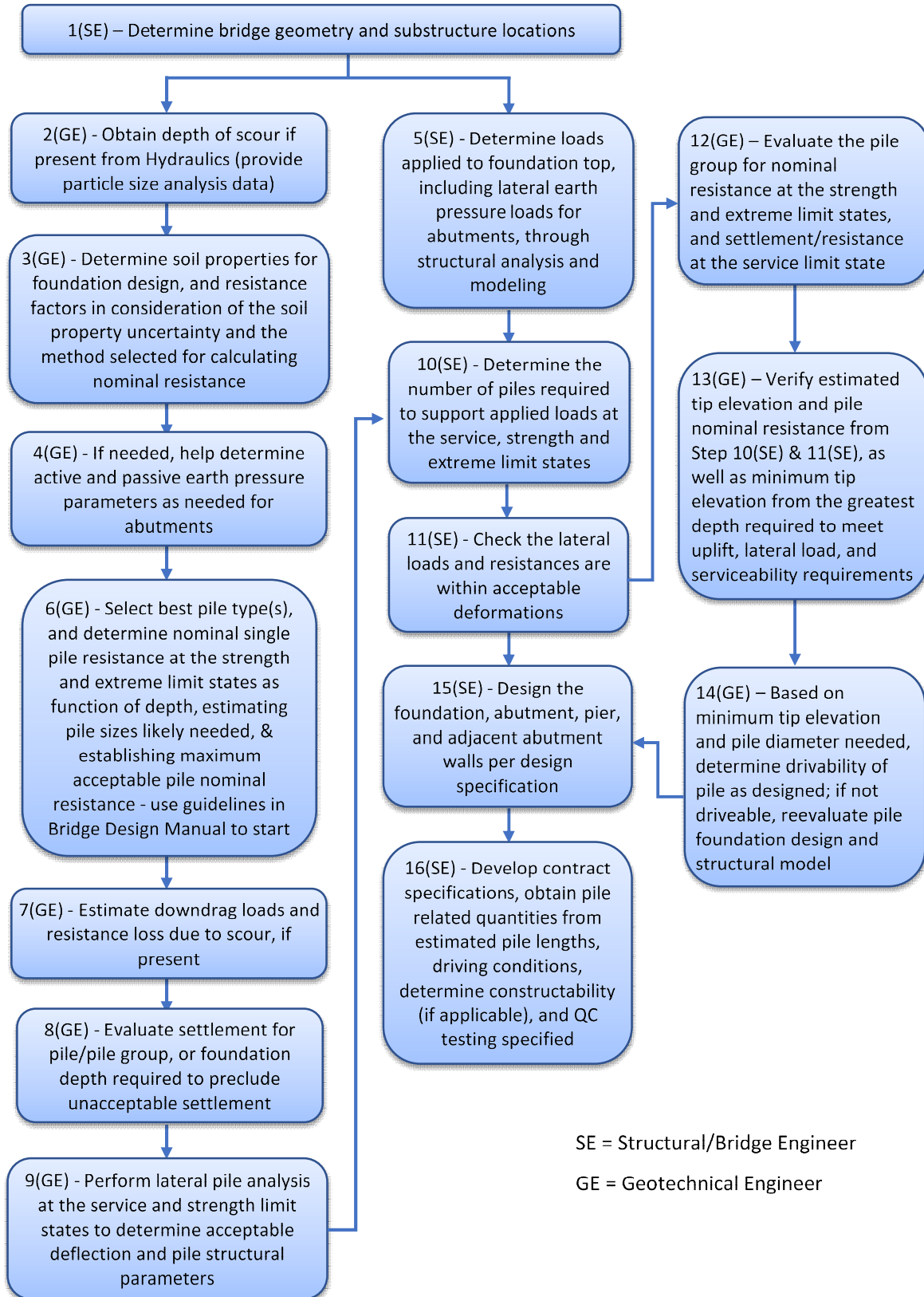

Figure 24: General Flowchart for LRFD Pile/Shaft Design

#### 9.4.3.2.2 Driven Pile Nominal Resistance Determination

The *MDOT Bridge Design Manual* Section 7.03.09.B provides standard pile sizes and nominal driven axial pile resistances used for bridge foundation design. These sizes and standard resistances should be used unless subsurface conditions, structural loads/stresses, or economics warrant using other combinations of pile type and resistance values.

To obtain these standardized nominal pile resistances, boring depths should be of adequate depth so that the typical nominal pile resistances are obtained. It is not acceptable to limit pile resistance based on “not having enough soils data” unless unusual subsurface conditions exist (i.e., artesian conditions). This practice not only tends to provide an inefficient design, but piles tend to be driven deeper during construction than estimated on the plans. This adds unexpected costs to the project.

All driven piles must be accepted based on the nominal resistance determined from

- The dynamic formula (Modified Gates Formula),
- Dynamic measurements with signal matching (Pile Driving Analyzer/Case Pile Wave Analysis Program (PDA/CAPWAP)), or
- Full-scale load testing in addition to dynamic measurements with signal matching.

Pile acceptance based solely on wave equation or static analysis are not acceptable methods of quality control unless otherwise approved by the GSS. For nominal driven pile resistances greater than 600 kips, dynamic measurements with signal matching must be specified in the contract documents. The Modified Gates Formula for pile driving quality control and design must not be used when the nominal pile driving resistance is greater than 600 kips. Additionally, this formula is not recommended as a driving quality control measure when nominal pile driving resistances are less than 250 kips unless some modifications are made to the resistance factor. This modification is described in the following paragraph. It should be noted that this equation becomes considerably less reliable/accurate when applied to pile resistances less than 250 kips or greater than 600 kips.

When determining the nominal driving pile resistance ( $R_{ndr}$ ) in design and construction, the resistance factors ( $\phi_{dyn}$ ), with the exception of the dynamic formula, adhere to the guidelines provided in the *AASHTO LRFD Bridge Design Specifications*. A resistance factor ( $\phi_{dyn}$ ) of 0.5 versus 0.4 is utilized by MDOT when the Modified Gates Formula is specified as the quality control measure for nominal driving resistances 250 kips and greater. For nominal driving resistances from 150 kips and less than 250 kips, a resistance factor of 0.4 must be used. Note that the Modified Gates Formula is for end of driving conditions only and does not apply at the beginning of redrive conditions. In

addition, when dynamic measurement and signal matching is specified, the 0.65 resistance factor has been derived based on beginning of redrive conditions and is not applied at the end of drive conditions unless approved by the GSS. More information on the resistance factors is outlined in the *MDOT Bridge Design Manual* Section 7.03.09.C.

In certain soil conditions, using a waiting period and restrrike after initial pile driving may be advantageous in optimizing the pile foundation design when dynamic measurement and signal matching is specified. After initially driving the piles to a specified tip elevation, the piles are allowed to “set up” for a specified waiting period, which allows pore water pressures to dissipate and soil strength to increase. The piles are then instrumented and restruck to confirm the required nominal resistance. The length of the waiting period depends primarily on the strength and drainage characteristics of the subsurface soils (how quickly the soil can drain) and the required nominal resistance. The minimum waiting period should be 48 hours unless otherwise specified by the engineer. In certain cases, more than 48 hours may be required to allow sufficient set up to occur to recognize the economic benefits of this process. In this case, the Geotechnical Engineer must place a note on the plans specifying the required time interval. Additionally, this time interval should be discussed during the design process and incorporated into the development of the project schedule. In summary, the pile design should compare the cost and risk of extending the standard waiting period to gain sufficient strength versus designing and driving the piles deeper to achieve the required resistance.

#### 9.4.3.2.3 Other Driven Pile Considerations

*Artesian Conditions* – Michigan has areas where confined aquifers are present and artesian conditions exist. Reviewing well logs in the area, speaking with local well drillers, and reviewing existing soil borings can provide some insight into where these conditions exist. When considering foundation types, MDOT’s policy is to avoid penetration into known confined aquifer layers unless otherwise approved by the GSS.

The previously mentioned standard nominal resistances may not be obtained prior to penetrating the confined stratum and, as a result, requires the Geotechnical Engineer to specify lower capacity piles. In most cases, the Geotechnical Engineer recommends a maximum pile tip elevation sufficiently above the confined aquifer to maintain the integrity of the confining layer. The maximum pile tip elevation must be shown on the Soil Boring Data sheet. Depending on the situation, it may be prudent to specify dynamic testing and signal matching so that a delayed restrrike can be used if needed to obtain the specified nominal pile resistance.

*Vibrations* – Piles driven into the ground cause vibrations that may be of concern if buildings, utilities, or other existing structures are present nearby. Several factors must be considered in this analysis including, but not limited to, structure/utility foundation type and age, distance from pile driving to structure/utility, and sensitivity of structure/utility to the vibration frequency and magnitude caused by the anticipated pile driving. Potential mitigation measures are to move/support the utility or to pre-bore pile locations of concern. If it is deemed that the vibrations caused by pile driving cannot be mitigated within tolerable risk, a low vibration foundation such as micropiles or drilled shafts may provide an alternate foundation solution.

Shakedown settlement can occur on sites where vibrations from pile driving cause adjacent soils within a certain distance of the pile to settle. Assessing this potential is crucial in part-width construction sites or where adjacent pavement, utilities and/or structures are located within the shakedown zone. This is especially true for structures that are supported on shallow foundations, which bear on cohesionless soils. MDOT funded a research project to study shakedown settlement and subsequently developed a spreadsheet to help engineers assess this risk. The research report titled *Effect of Pile-Driving Induced Vibrations on Nearby Structures and Other Assets* can be downloaded from the MDOT [Research Administration](#) website. As part of the design process on projects, evaluation of the shakedown potential by the Geotechnical Engineer must occur on potentially troublesome sites. The spreadsheet for assessing the shakedown potential can be obtained by contacting the GSS foundation analysis engineer.

*Pre-Boring* – Aside from vibration mitigation, pre-boring may also be necessary to allow piles to penetrate hard or dense soil layers and to achieve the minimum required penetration or lessen skin friction in area of downdrag. Piles extending through embankment fill should penetrate a minimum of 10 feet into natural ground. Greater minimum penetration is sometimes needed due to estimated scour or when deep pile embedment is needed to develop adequate resistance to lateral loads. Pre-boring typically extends to the specified elevation and the pile is driven in the drilled hole to the specified nominal resistance or absolute refusal. The feasibility of pre-boring piles is highly dependent on soil and groundwater conditions. When pre-boring is required, the Geotechnical Engineer should account for this in the driving analysis and specify a pre-bore elevation on the soil boring data sheet.

*Constructability* – Pile installation requires leads that support the driving hammer and driven pile. These are typically free-hanging from a crane and require ample overhead space. When considering this type of foundation, the overhead space should be free of all utilities if possible. In certain situations, insulation or temporary shutdown of overhead power lines can be performed to prevent “arcing” of electricity from the line

to the pile leads but must be coordinated and agreed upon with the utility company during the design phase.

When installing batter piles, the Geotechnical Engineer should also consider any conflicts with the proposed cofferdam/temporary sheeting lines. Furthermore, any safety issues due to the pile leads/hammer overhanging travel lanes must be addressed.

Occasionally within Michigan's geology, cobbles, boulders, and bedrock may be encountered within the proposed pile driving zone. Where these conditions exist, the Geotechnical Engineer needs to consider the risk of pile damage when driving through these subsurface conditions. It is common practice to specify pile points where these conditions are encountered.

#### 9.4.3.3 Micropiles

Micropiles are small diameter (less than 12 inches), drilled and grouted nondisplacement piles that are reinforced. They are capable of withstanding axial loads similar to those used for driven steel piles. Micropiles are considered very versatile because they are installed by methods that cause minimal disturbance to adjacent structures and soil, can be installed where access is restrictive, and can be installed in all soil types and ground conditions. However, in comparison to spread footings and driven piles, micropiles are more costly and should be considered as an alternate to address special circumstances.

Geotechnical analysis and design of micropiles must adhere to Section 10 of the *AASHTO LRFD Bridge Design Specifications* (most current version), except as specified herein and in the *MDOT Bridge Design Manual*. Additional information on micropile design may be found in the *FHWA Micropile Design and Construction Reference Manual* (Publication No. FHWA NHI-05-039). [Figure 24: General Flowchart for LRFD Pile/Shaft Design](#) provides a flowchart that illustrates the design process and interaction required between structural and geotechnical engineers to complete a micropile foundation design.

##### 9.4.3.3.1 Micropile Diameter

Typical micropile casing outside diameter varies from 5.5 to 10.75 inches. The majority of MDOT projects have utilized 7-inch and 9.625-inch diameter casing for installation on bridge foundation projects. These two sizes are more commonly available and should be specified on MDOT projects unless loads or other site conditions warrant going outside these sizes.

#### 9.4.3.3.2 Micropile Nominal Resistance Determination

Nominal axial resistances utilizing the sizes above can range from 100 kips to 600 kips and can be dependent on soil/rock strata, magnitude of bridge loads transferred to the pile, and site limitations.

Micropiles installed in soil or in weathered/discontinuous rock must only account for the side friction bond between the grout and soil/rock when determining the nominal resistance unless otherwise approved by the GSS.

#### 9.4.3.3.3 Other Micropile Considerations

Part of the micropile installation process is to use potable water as a flushing medium. Appropriate soil erosion and sedimentation control measures must be included as part of the contract documents to ensure appropriate handling of the discharged water.

*Constructability* - As part of the micropile construction process, a certain number of micropiles require verification and proof load testing. Typically, either a dead load or reaction piles are used as the counterweight in the load test process. The Geotechnical Engineer must consider site constraints when designing and specifying these types of load tests on a specific project site. When installing battered micropiles, the Geotechnical Engineer should also consider any conflict with the proposed cofferdam/temporary sheeting lines that may impede the installation process.

#### 9.4.3.4 Drilled Shafts

A drilled shaft (also called drilled caisson) is a circular deep foundation element that is constructed by excavating a hole in most cases with power auger equipment. Reinforcing steel and concrete are then placed within the excavation. In unstable soils such as soft clays and cohesionless soils, casing or drilling slurry is used to maintain the stability of the hole. Drilled shafts should be considered when large axial and/or lateral loads are anticipated, and favorable geologic conditions exist (see [Bridge Design Manual](#)). This can occur with large span lengths or at stream crossings where predicted scour depths are deep that can result in large unsupported lengths on the deep foundation element. Drilled shaft diameters for bridge construction typically range from 2.5 to 6 ft in diameter. Larger shafts have been utilized on some projects, but smaller shafts (less than 2.5 ft) for the support of bridge foundations are not allowed per the AASHTO code.

Geotechnical analysis and design of drilled shafts must adhere to Section 10 of the *AASHTO LRFD Bridge Design Specifications* (most current version), except as specified herein and in the *MDOT Bridge Design Manual*. Additional information on drilled shaft design may be found in the *FHWA Drilled Shafts: Construction Procedures and LRFD*

*Design Methods* (Publication No. FHWA NHI-10-016, GEC-010). [Figure 24: General Flowchart for LRFD Pile/Shaft Design](#) provides a flowchart that illustrates the design process and interaction required between structural and geotechnical engineers to complete a drilled shaft foundation design.

#### 9.4.3.4.1 Drilled Shaft Nominal Resistance Determination

Nominal axial resistances utilizing the sizes above typically range from 600 to 2000 kips and are dependent on the soil/rock strata, magnitude of bridge loads transferred to the drilled shaft, length/diameter of the element, and site limitations. In some cases where shafts bear on competent rock, nominal axial resistances may exceed 2000 kips. The shaft axial nominal resistance is determined from the tip resistance and/or shaft side resistance. Since the maximum value of each of these is very unlikely to occur at the same time, it is MDOT's practice to determine the axial nominal resistance utilizing only skin friction between the shaft and soil/rock interface. When either tip resistance or both side and tip resistance is used to determine the nominal axial resistance, the Geotechnical Engineer must consider strain compatibility and complete a detailed analysis to determine what amount of each can be utilized while maintaining acceptable levels of displacement at the service limit state. The references provided in the preceding subsection provide detailed guidance and discussion on this topic. Approval from the GSS is also required when utilizing this design approach.

Another design consideration to account for is when temporary, left in place casing or permanent casing is utilized within the drilled shaft bond zone. Since steel casing will generally reduce the side resistance of a shaft, the Geotechnical Engineer must account for some reduction within this bond zone area.

#### 9.4.3.4.2 Other Drilled Shaft Considerations

*Nearby Structures* – Where shaft foundations are installed adjacent to existing structures, the influence of the existing structure(s) on the behavior of the foundation and the effect of the foundation on the existing structures, including vibration effects due to casing installation, should be investigated. In addition, the impact of casing soils during shaft excavation on the stability of foundations supporting adjacent structures should be evaluated. Where existing structure foundations are adjacent to the proposed shaft foundation or where a shaft excavation cave-in could adversely affect an existing foundation, the design should require that casing to be advanced as the shaft excavation proceeds.

*Artesian Conditions* – Michigan has areas where confined aquifers are present and artesian conditions exist. Reviewing well logs in the area, speaking with local well drillers, and reviewing existing soil borings can provide some insight into where these

conditions exist. When considering foundation types, it is MDOT's policy to avoid use of drilled shafts if artesian conditions exist unless otherwise approved by the GSS.

*Gas pockets* – The general presence of methane in the overburden and rock strata in Michigan has been chronicled at various locations. When soil boring logs indicate the presence of gas pockets, MDOT's policy is to avoid the use of drilled shafts unless otherwise approved by the GSS.

*Aesthetics* – Temporary steel casing is sometimes used for constructing the drilled shaft and is left in place when completed. The designer should consider aesthetic requirements for the project and, if necessary, specify cut-off elevations on the plans for the casing that is left in place.

*Constructability* – Drilled shaft installation equipment requires sufficient access and ample space to operate. These aspects must be considered by the Geotechnical Engineer and bridge engineer during the design phase of the project. Logistics such as the turning radius required for spoil spin-off, staging of pump trucks, material handling, and area for spoil disposal and equipment should be considered as part of this planning.

For all drilled shafts supporting bridges, crosshole sonic log testing must be installed on each shaft. Language to provide appropriate access tube types and spacing, testing firm qualifications, and appropriate installation and testing requirements must be provided in the bridge drilled shaft special provision.

#### 9.4.4 FOUNDATION DESIGN GUIDELINES

##### 9.4.4.1 Deep Foundation Deflection Criteria

Excessive movement of the foundation supporting bridges may lead to discontinuities in the slope of the driving surface, damage to the bridge structure, jamming of bearings, poor bridge deck drainage, and expansion joints, or even collapse. The Geotechnical Engineer, in collaboration with the structural/bridge engineer, must estimate the maximum settlement and lateral movement anticipated in the foundation to ensure they are within tolerable limits. Acceptable lateral deflections need to be evaluated on a case-by-case basis in consultation with the structural/bridge engineer since deflections will be based upon numerous factors (i.e., type of superstructure, loading type, pile head fixity, bridge span).

##### 9.4.4.2 Lateral Loads

Multiple rows of deep foundation elements will have less lateral resistance than the sum of single foundation elements because of pile-soil-pile interactions that take place in the group. This is due to the "shadowing" effects caused by foundation elements in the front row. As a result, appropriate reduction factors must be applied to groups of

foundation elements that have center-to-center spacing close enough to cause this to happen. The *AASHTO LRFD Bridge Design Specifications Manual*, Section 10, provides additional guidance on determining appropriate reduction factors.

#### 9.4.4.3 Scour

The effects of scour must be evaluated in determining the required deep foundation depth. The foundation must be designed so that it provides the needed geotechnical resistance during the design scour events. Foundation depth must be sufficient to provide the required nominal axial and lateral resistance. Scour depths are calculated for both the 100-year (“design flood”) and 500-year (“check flood”) events. In addition, the foundation element must also be designed to resist debris/ice loads occurring during the flood events in addition to the loads applied from the structure. The axial resistance lost due to scour should be determined using a static analysis and should not be factored.

For driven pile design, the pile will need to be installed to the required axial resistance plus the skin friction resistance that will be lost due to scour. From the basic LRFD equation:

$$\sum \eta_i \gamma_i Q_i \leq \phi R_n - \text{See Section } \a href="#">9.4.1 \text{ for term definitions}$$

The summation of the factored loads ( $\sum \eta_i \gamma_i Q_i$ ) must be less than or equal to the factored resistance ( $\phi R_n$ ). Therefore, the nominal resistance ( $R_n$ ) must be greater than or equal to the sum of the factored loads divided by the resistance factor ( $\phi$ ). This can be written as follows:

$$R_n \geq (\sum \gamma_i Q_i) / \phi_{\text{dyn}}$$

For scour conditions, the total or nominal driving resistance ( $R_{\text{ndr}}$ ) needed to obtain  $R_n$  is therefore:

$$R_{\text{ndr}} = R_n + R_{\text{scour}}$$

$R_{\text{scour}}$  = skin friction, which must be overcome during driving through predicted scour zone (kips)

#### 9.4.4.4 Downdrag

Downdrag loads on piles, shafts, or micropiles must be evaluated as described in *AASHTO Bridge Design Specifications*, Article 3.11.8 and Section 10. If a downdrag condition exists, the resulting downdrag loads (DD) are included with the permanent load combinations used in structure design and an appropriate load factor is applied to

the downdrag loads. In addition to applying the downdrag loads on the load side of the LRFD equation, the downdrag loads must also be subtracted from the resistance side of the equation since this resistance will not be available for foundation support.

If downdrag is deemed to be an issue at a particular structure, the Geotechnical Engineer should consider mitigation through the following ways:

- Deeper installation of the foundation elements to obtain greater resistance that offsets the calculated downdrag,
- Isolation of the pile from the backfill through a steel pipe or extruded corrugated polypropylene sheets wrapped around the pile,
- Use of lightweight fills, or
- Implement a preloading or surcharge program prior to installing the foundation elements.

#### 9.4.4.5 Reuse of Existing Foundations

Reuse of the existing foundations are common when only the superstructure is scheduled for replacement. In this case, the foundation must be checked to ensure that the proposed superstructure does not overload the foundation or cause it to experience detrimental settlements. It is assumed that the substructure has been evaluated and meets the anticipated service life. In most cases, the existing plans provide maximum and average bearing pressures for different dead load and live load scenarios or pile loads that were used to design the foundation.

If the proposed superstructure loads result in bearing pressures or pile loads equal to or less than those existing on the structure, then reusing the foundation can be considered as an option. If the proposed loads result in higher loads than existing, then additional field investigation and analysis could be required. Depending on project/site constraints and amount of overload, possible mitigation options to consider are 1) change the type of the superstructure (steel vs. concrete beams), 2) retrofit the existing foundation with micropiles, or 3) reconstruct a new foundation system. It should be noted that option 3 requires a scope change of the project.

#### 9.4.5 OVERALL STABILITY

Overall stability of the bridge abutment and approach must be checked at the service limit state. A detailed overall stability analysis discussion including lateral squeeze analysis is discussed in Section [9.3.7.3](#).

When analyzing the stability of an abutment at a river crossing, there are times when either the bridge abutments or river is not perpendicular to each other. In these cases, modeling a

cross-section transverse to the river or abutment at the centerline of the bridge may not be the most critical section to analyze. [Figure 25](#) illustrates this scenario at a river crossing.

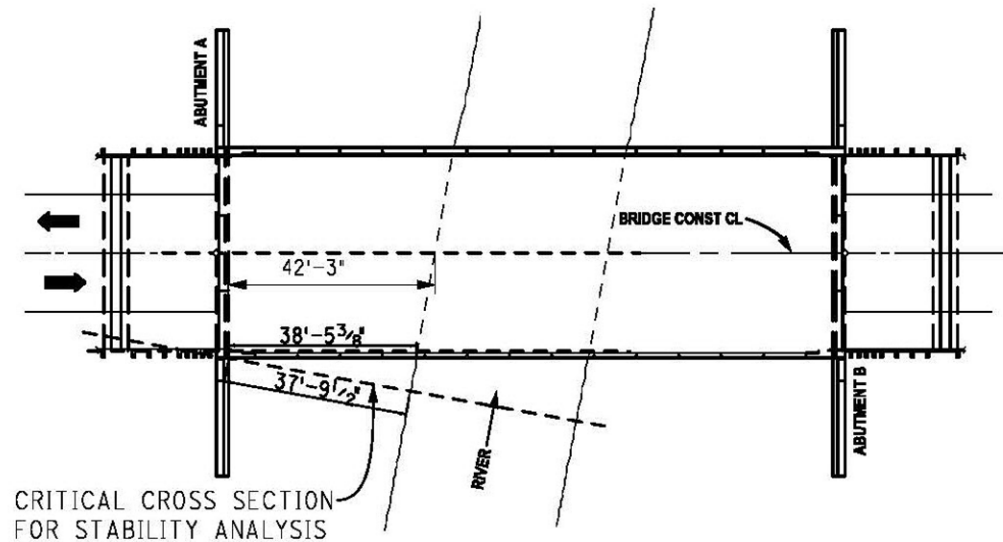

Figure 25: Abutment Stability Analysis Critical Section

## 9.5 FOUNDATION DESIGN—ALLOWABLE STRESS DESIGN (ASD) METHODOLOGY

While all new bridge construction uses the LRFD methodology for design, existing bridges considered for superstructure replacement or widening typically use the ASD methodology for foundation analysis. The type of design methodology should be determined at the beginning of the project by MDOT Bridge Design. This section discusses MDOT's criteria for the geotechnical design of existing or widened bridge foundations. These criteria adhere to methods and policy set forth in the following documents unless otherwise modified herein.

- Section 3 Loads and Section 4 Foundations of the 2002 AASHTO Standard Specifications for Highway Bridges, 17th Edition (ASSHB)
- Sections [9.4.3](#), [9.4.4](#), and [9.4.5](#) of the Manual, except for the parts related to LRFD methodology
- *MDOT Bridge Design Manual – Load Factor Design (LFD) Sections*
- MDOT Bridge Design Guides
- MDOT Drainage Manual

### 9.5.1 SPREAD FOOTINGS – ALLOWABLE STRESS DESIGN

Spread footing design must be in accordance with Section 4.4 of the ASSHB. The allowable bearing capacity must have a minimum factor of safety of 3.0. Allowable settlement of the existing structure due to the superstructure replacement and/or widening must be determined on a case-by-case basis for that specific structure. Additional settlement or differential

settlement between the existing and proposed structures estimated to be no greater than 0.5 inches is desired in these types of design scenarios. Estimated settlement greater than this amount must be approved by the GSS and bridge engineer.

### 9.5.2 DRIVEN PILES – ALLOWABLE STRESS DESIGN

Driven steel piles are typically used for support of foundation widenings when the existing structure is already founded on driven piles. Standard sizes and allowable vertical capacities are specified in [Section 7.03.09](#) of the *Bridge Design Manual*. Pile sizes and capacities outside the criteria specified must be approved by the GSS. Driven pile design must adhere to Section 4.5 of the ASSHB.

All driven piles must be accepted based on the pile capacity determined from

- The dynamic formula as specified in the 2003 Standard Specifications for Construction,
- Dynamic measurements with signal matching (PDA/CAPWAP),
- Or full-scale load testing in addition to dynamic measurements with signal matching.

In determining the estimated pile length for design when the dynamic formula (*Michigan Modified Engineering News Record*) is to be used as the quality control measure during construction, it is recommended that a minimum factor of safety of 2.5 be applied to the ultimate pile capacity as calculated by static analysis when determining the allowable pile capacity. When dynamic measurements and signal matching is to be used as the quality control measure in determining the allowable pile capacity, a minimum factor of safety of 2.25 can be applied to the ultimate capacity. For a full-scale load test with dynamic measurements and signal matching used as quality control, a minimum factor of safety of 1.9 can be applied to the ultimate capacity.

### 9.5.3 MICRPILES – ALLOWABLE STRESS DESIGN

Micropiles are sometimes used in bridge widening projects due to the low vibration nature of their installation or in low overhead. In addition, they are used to retrofit existing foundations that require additional foundation support caused by additional loading from the new superstructure replacement. Since micropile design is not discussed in the ASSHB manual, the design and construction of micropiles must be in accordance with the *FHWA Micropile Design and Construction Reference Manual, 2005 (NHI-05-039)*. In addition, MDOT has developed special provisions for micropiles that provide helpful design information based on previous experience. A minimum factor of safety of 2.0 must be used when determining the axial compressive capacity of a micropile provided verification and proof testing is performed during construction. [Section 9.4.3.3.3](#) of the Manual should also be used when considering design and construction of micropiles.

### 9.5.4 DRILLED SHAFTS – ALLOWABLE STRESS DESIGN

Design of drilled shafts must be in accordance with Section 4.6 of the ASSHB. Another useful resource is the FHWA Publication FHWA-IF-99-025, *Drilled Shaft: Construction Procedures and*

*Design Methods*, 1999, authored by Reese and O’Neil. In addition, MDOT has developed special provisions for drilled shafts that provide helpful construction requirements based on previous experience. Section [9.4.3.4.2](#) of the Manual should also be used when considering design and construction of drilled shafts. A minimum factor of safety of 2.5 must be used when determining the axial compressive capacity from static analysis.

## 9.6 RETAINING WALL DESIGN

Retaining walls are typically included in projects to minimize construction in wetlands, widen existing facilities, and minimize the amount of right-of-way needed in urban environments. Projects modifying existing facilities often need to retrofit or replace existing retaining walls or widen abutments for bridges. All abutments and walls within the right-of-way should be designed and constructed in accordance with the following documents:

- MDOT Bridge Design Manual,
- MDOT Bridge Design Guides,
- MDOT Road Design Manual,
- MDOT Drainage Manual,
- Section 3 and 11 of the AASHTO LRFD Bridge Design Specifications (most recent version),
- AASHTO Standard Specifications for Highway Bridges, 2002, 17th Edition, (Temporary Walls Only), and
- FHWA guidance documents for that specific wall type.

Wall types can be classified into fill wall and cut wall applications. Examples of fill walls include standard cantilever walls, modular gravity walls (gabions, modular block), and Mechanically Stabilized Earth (MSE) walls. Cut walls include soil nail walls, cantilever soldier pile walls, and ground anchored walls. Some wall types require a unique design for both internal and external stability. Other walls have standardized or proprietary designs for internal stability with external stability analyzed by the Geotechnical Engineer. Many times, Geotechnical Engineers need to not only develop their own designs but also evaluate and review standardized and proprietary wall designs. Therefore, it is important that the Geotechnical Engineer has an understanding of the applications for each wall type, subsurface exploration and design requirements, construction methods, and relative costs. The following tables provide different types of wall systems and general evaluation factors that can be used by designers for preliminary wall selection on a project.

During the design process of the wall system, it is important to identify various design requirements and constructability concerns such as:

- Surcharge loads from adjacent structures
- Backslope and toe slope geometries
- Right-of-way restrictions

- Material type
- Aesthetics
- Tolerable horizontal and vertical movements of wall and adjacent structures/properties
- Easements
- Utilities
- Excavation limits
- Wetlands
- Construction staging – maintenance of traffic

Once these items are defined, an analysis and design plans can be completed to meet the project requirements.

Many of the wall systems discussed in the following sections can be used for both temporary and permanent conditions. For the purpose of design, any wall system that is expected to remain temporary for more than three years must be designed for the requirements of permanent structures.

Table 16: Fill Wall Evaluation Factors (modified after Earth Retaining Structures, 2008, FHWA-NHI-07-071)

Wall Type	Application <sup>1</sup>	Cost Effective Height Range	Required ROW <sup>2</sup>	Differential Settlement Tolerance <sup>3</sup>	Relative Cost	Advantages	Disadvantages
Concrete Gravity	P	3 – 10 ft	0.5H – 0.7H	1/500	Medium/High	<ul style="list-style-type: none"> <li>• Durable</li> <li>• Concrete facing can meet aesthetic requirements</li> </ul>	<ul style="list-style-type: none"> <li>• Relatively long construction time</li> </ul>
Concrete Cantilever	P	6 – 30 ft	0.4H – 0.7H	1/500	Medium/High	<ul style="list-style-type: none"> <li>• Durable</li> <li>• Concrete can meet aesthetic requirements</li> </ul>	<ul style="list-style-type: none"> <li>• Relatively long construction time</li> <li>• Deep foundation support may be necessary</li> </ul>
Concrete Counterfort	P	30 – 60 ft	0.4H – 0.7H	1/500	Medium/High	<ul style="list-style-type: none"> <li>• Durable</li> <li>• Concrete can meet aesthetic requirements</li> </ul>	<ul style="list-style-type: none"> <li>• Relatively long construction time</li> <li>• Deep foundation support may be necessary</li> </ul>
Modular Block	P	6 - 15 ft	3 – 7 ft	1/200	Low/Medium	<ul style="list-style-type: none"> <li>• Does not require skilled labor</li> <li>• Relatively fast construction time</li> <li>• Flexibility in aesthetic facings</li> </ul>	<ul style="list-style-type: none"> <li>• Limited application</li> </ul>
Gabion	P/T	6 – 15 ft	0.5H – 0.7H	1/50	Low/Medium	<ul style="list-style-type: none"> <li>• Does not require skilled labor or specialized equipment</li> </ul>	<ul style="list-style-type: none"> <li>• Significant labor required</li> <li>• Need adequate source of stone</li> <li>• Application use in specialized areas only</li> </ul>
MSE Wall (precast facing)	P	10 – 100 ft	0.7H – 1.1H	1/100	Medium	<ul style="list-style-type: none"> <li>• Does not require skilled labor or specialized equipment</li> <li>• Flexibility in aesthetic facings</li> </ul>	<ul style="list-style-type: none"> <li>• Requires use of select backfill</li> <li>• Metallic reinforcement subject to corrosion in aggressive environment</li> </ul>
MSE Wall (modular/segmental block facing)	P	6 – 50 ft	0.7H – 1.1H	1/200	Medium	<ul style="list-style-type: none"> <li>• Does not require skilled labor or specialized equipment</li> <li>• Segmental blocks are easily handled</li> </ul>	<ul style="list-style-type: none"> <li>• Requires use of select backfill</li> <li>• Positive reinforcement connection to blocks is difficult to achieve</li> </ul>
MSE Wall (geotextile/geogrid/welded wire facing)	T	6 – 50 ft	0.7H – 1.1H	1/60	Low/Medium	<ul style="list-style-type: none"> <li>• Does not require skilled labor or specialized equipment</li> </ul>	<ul style="list-style-type: none"> <li>• Facing may not be aesthetically pleasing</li> <li>• Geotextile walls have flexible facing</li> </ul>

<sup>1</sup> P – Permanent, T – Temporary

<sup>2</sup> Right-of-Way (ROW) - ROW requirements expressed as the distance (as a fraction of wall height, H) behind the wall face where fill or footing placement is generally required, except where noted. Additional distance for temporary excavation may be required for constructability.

<sup>3</sup> Ratio of the difference in vertical settlement between two points along the wall to the horizontal distance between the points.

Table 17: Cut Wall Evaluation Factors (modified after Earth Retaining Structures, 2008, FHWA-NHI-07-071)

Wall Type	Application <sup>1</sup>	Cost Effective Height Range	Required ROW <sup>2</sup>	Relative Cost	Advantages	Disadvantages
Sheet Pile - Cantilever	P/T	Up to 15 ft	None <sup>3</sup>	Low	<ul style="list-style-type: none"> <li>• Rapid construction</li> <li>• Readily available</li> </ul>	<ul style="list-style-type: none"> <li>• Difficult to construct in hard ground or through obstructions</li> <li>• Vibrations caused by installation can create structural damage, aesthetic cracks, and/or settlement of adjacent structures and pavements</li> </ul>
Soldier Pile/Lagging	P/T	Up to 15 ft	None <sup>3</sup>	Medium	<ul style="list-style-type: none"> <li>• Rapid construction – Driven System</li> <li>• Soldier piles can be driven or drilled</li> </ul>	<ul style="list-style-type: none"> <li>• Relatively long construction time</li> <li>• Deep foundation support may be necessary</li> </ul>
Tangent Pile Wall	P/T	6 - 15 ft	None <sup>3</sup>	Low/Medium	<ul style="list-style-type: none"> <li>• Adaptable to irregular layout</li> <li>• Can control wall stiffness</li> <li>• Low vibration installation possible</li> </ul>	<ul style="list-style-type: none"> <li>• Difficult to maintain vertical tolerances in hard ground</li> <li>• Requires specialized equipment</li> <li>• Significant spoils for disposal</li> </ul>
Secant Pile Wall	P/T	6 – 15 ft	None <sup>3</sup>	Low/Medium	<ul style="list-style-type: none"> <li>• Adaptable to irregular layout</li> <li>• Can control wall stiffness</li> <li>• Low vibration installation possible</li> </ul>	<ul style="list-style-type: none"> <li>• Requires specialized equipment</li> <li>• Significant spoils for disposal</li> </ul>
Anchored <sup>4</sup>	P/T	15 – 70 ft	0.6H + anchor bond length	Medium/High	<ul style="list-style-type: none"> <li>• Can resist large lateral pressures</li> <li>• Adaptable to varying site conditions</li> </ul>	<ul style="list-style-type: none"> <li>• Requires skilled labor and specialized equipment</li> <li>• Anchors may require permanent easements</li> </ul>
Soil Nail	P/T	10 – 70 ft	0.6H – 1.0H	Medium	<ul style="list-style-type: none"> <li>• Smaller equipment required for installation</li> <li>• Adaptable to irregular wall alignment</li> </ul>	<ul style="list-style-type: none"> <li>• Nails may require permanent easements</li> <li>• Difficult to construct and design below water table or in soil that excessively sloughing when excavated</li> </ul>

<sup>1</sup> P – Permanent, T – Temporary

<sup>2</sup> Right-of-Way (ROW) - ROW requirements expressed as the distance (as a fraction of wall height, H) behind the wall face where wall anchorage components are installed.

<sup>3</sup> ROW required if wall include anchors.

<sup>4</sup> Anchored walls are walls that require some type of tieback /anchored system. The four wall systems mentioned prior to this system can all be anchored if required by project design criteria.

### 9.6.1 GRAVITY RETAINING WALLS

Gravity retaining walls are constructed of either cast-in-place concrete with reinforcement or precast concrete units. Gravity, semi-gravity, and modular block walls fall under the umbrella of gravity type walls typically used at MDOT. These types of walls depend on the weight of concrete and soil to resist external forces such as overturning and sliding. Semi-gravity walls are commonly used for earth retaining structures and bridge abutments in fill situations. They can also be used in cut applications, but for such an application the area behind the wall must be temporarily sloped or supported.

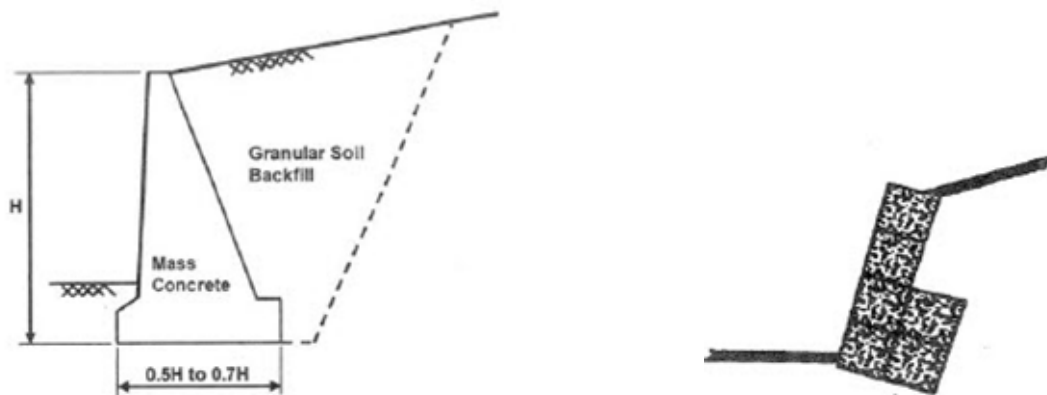

Figure 26: Gravity Mass Concrete Wall and Gabion Basket Wall (AASHTO LRFD, November 2017)

Gravity type walls consist of a concrete mass to retain the fill from a grade difference.

Semi-gravity retaining walls consist of cantilever, counterfort, or buttress type walls, which use soil weight in addition to the concrete to resist lateral pressures caused by the earth backfill (See [Figure 28](#)). Modular gravity walls consist of concrete blocks stacked on top of one another (See [Figure 27](#)). Gabion baskets filled with coarse stone are another modular wall system but are only used by MDOT in unique applications (See [Figure 26](#)). Prior approval by the GSS must be obtained prior to use of gabion baskets. Modular blocks can only be used in landscaping or roadway applications. With the exception of a Geosynthetic Reinforced Soil (GRS) Abutment, modular blocks are not used to support or retain fill that is supporting bridge elements. A special provision for modular blocks is required when using this type of wall system on a project.

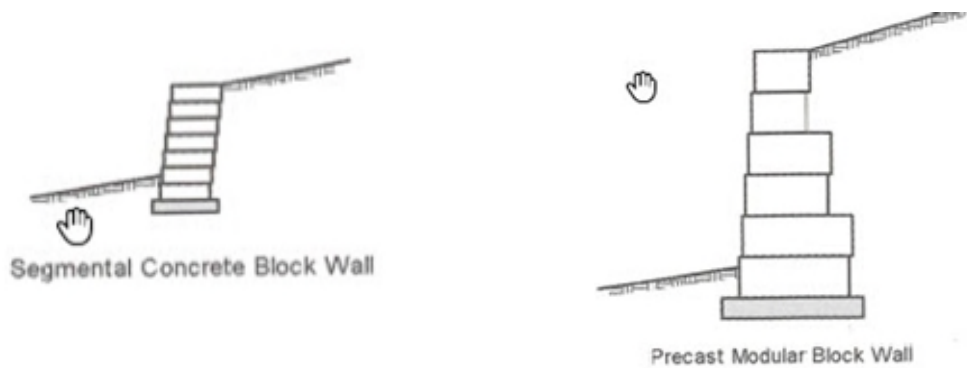

Figure 27: Gravity – Precast Segmental and Modular Block Walls (AASHTO LRFD, November 2017)

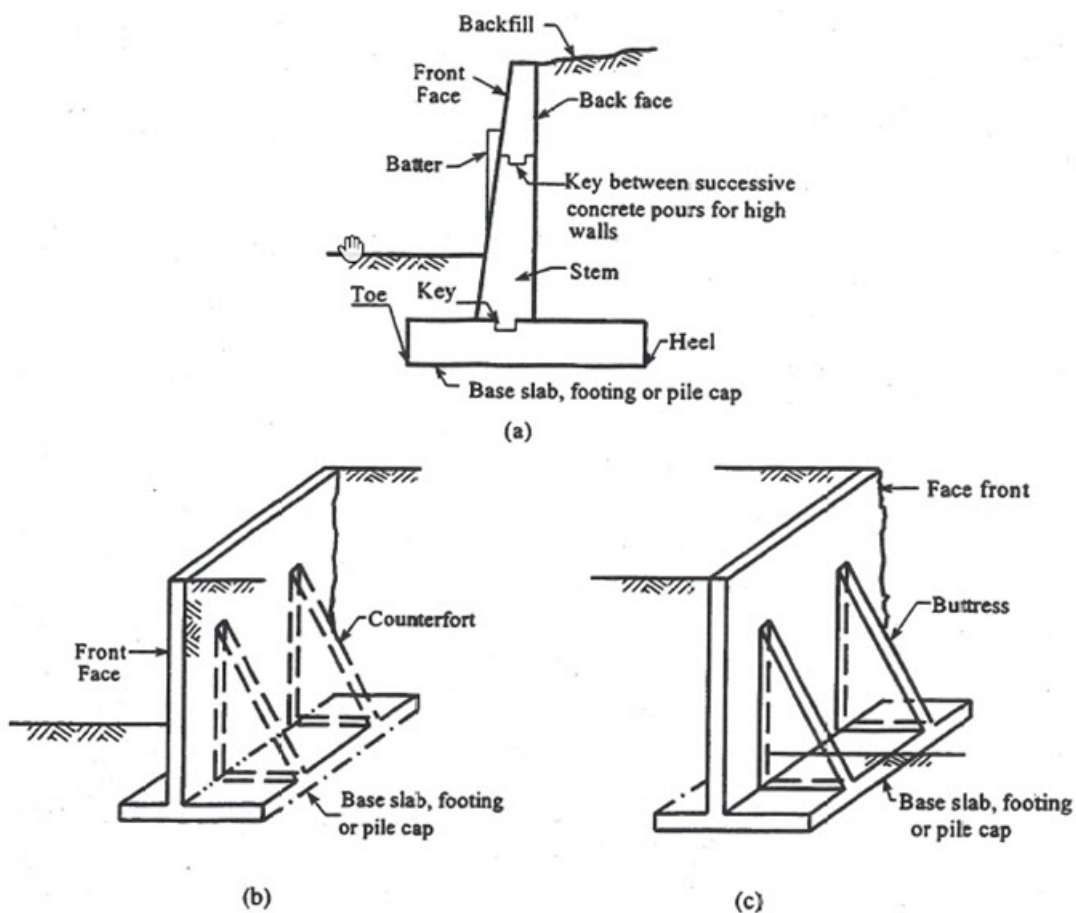

Figure 28: Semi-Gravity Retaining Walls -a) Cantilever, b) Counterfort, c) Buttress (Earth Retaining Structures, June 2006)

The design of gravity walls includes analyzing the overall stability, bearing, deformation (vertical and horizontal), sliding, and overturning. Following the design guidance provided in Section [9.6](#), the Geotechnical Engineer or structural engineer must ensure the wall design meets these

external stability requirements. If a deep foundation is used to support the wall system, the analyses must be performed using the procedures noted in Section 9.4.

### 9.6.2 MSE WALLS

Permanent Mechanically Stabilized Earth retaining walls consist of precast concrete panels or cast-in-place facing connected to a reinforced soil mass. MDOT requires the reinforced mass to consist of alternating layers of granular material and steel reinforcing. When using an MSE wall on a project, the Geotechnical Engineer is responsible for performing an external stability and deformation (vertical and horizontal) analysis of the wall system. The external stability analysis consists of checking bearing resistance, overall and compound stability, eccentricity, and sliding. Since these walls are proprietary systems, the wall designer is responsible for designing and checking the internal stability components such as tensile and pullout resistance of reinforcement and structural resistance of face elements and face element connections. Shop drawings are then developed and submitted to MDOT for review and approval. The special provision for *Mechanically Stabilized Earth Retaining Wall System* is used when this wall system is selected on a project. Aside from the manuals noted in Section 9.6, the *FHWA GEC 11, Design and Construction of Mechanically Stabilized Earth Walls* provide additional guidance and details for the design of these types of walls.



Figure 29: Generic Cross-Section of an MSE Structure

A segmental block retaining wall system consists of smaller precast blocks that are connected to a geosynthetic reinforced soil mass. The special provision for *Segmental Block Retaining Wall, Reinforced* provides standard requirements when this type of reinforced soil mass system is used on a project. MDOT allows segmental blocks for landscaping and noncritical wall applications.

### 9.6.3 NONGRAVITY CANTILEVERED WALLS

A nongravity cantilevered wall is an earth retaining system that derives lateral resistance through embedment of vertical wall elements and supports retained soil with facing elements. The vertical wall elements and facing may be continuous such as secant or tangential drilled shafts and auger cast-in-place piles, or steel sheet piles. Alternatively, vertical elements may consist of discrete elements (soldier piles) such as driven piles or drilled shafts spanned by a structural facing such as timber lagging, shotcrete, steel sheets, or precast concrete panels.

*Steel Sheet Pile Wall* - Steel sheet piling is the most common nongravity cantilevered wall system used at MDOT (See [Figure 30](#), a). There are typically three steel sheet pile bid items specified for MDOT projects: temporary, temporary left in place, and permanent. Temporary and temporary left in place walls are designed by the contractor's engineer while permanent sheet pile walls are designed by the Geotechnical Engineer in conjunction with the project's structural engineer.

- Temporary, Steel Sheet Piling – The designer specifies locations and checks design viability where sheet piling is anticipated to be needed during construction. During construction, the contractor's engineer performs a design analysis and submits a design package for review by MDOT. Within the submittal package, the contractor's engineer specifies the type, size, depth, and other appurtenances needed for the temporary wall. For temporary conditions, the wall must be designed for a design life of three years unless the project warrants a longer design life duration. Quantities should be estimated based on the area of earth retention. How to take these measurements in the field is described in more detail in the *Standard Specifications for Construction*. Once the sheet piling is no longer needed, it is removed by the contractor.
- Temporary, Steel Sheet Piling, Left in Place – All the requirements discussed for the temporary, steel sheet piling also apply to this item with only one difference. Once the sheet piling is no longer needed, it is left in place. Since it is left in place, the steel sheeting must meet Buy America requirements on any federally funded projects.
- Steel Sheet Piling, Permanent – Permanent sheet pile walls must have a minimum design life of 75 years per the *MDOT Bridge Design Manual*. The Geotechnical Engineer is responsible for selecting the size/type of permanent sheet pile to be used, depth to which it will be installed, and estimating deflection limits. Independently or collaborating with the structural engineer, structural design requirements must also be analyzed as part of the design phase. Quantities are determined based on the lines and length below cut-off shown on the plans or determined by the engineer. Permanent

steel sheet piling used on any federally funded projects must meet Buy America requirements.

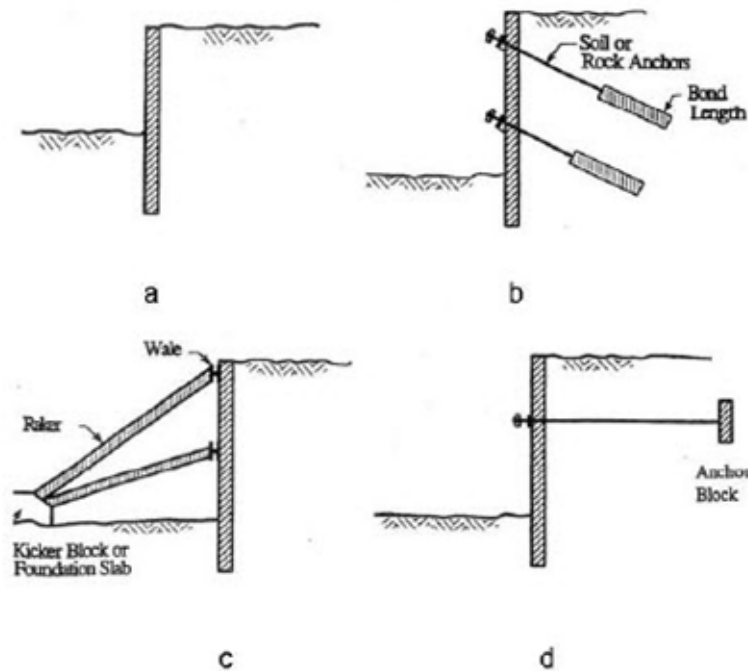

Figure 30: Nongravity Retaining Walls-a) Cantilever, b) Anchored, c) Braced, d) Deadman Anchored (Earth Retaining Structures, June 2008)

Cantilever sheet pile walls embedded in favorable soils can typically be designed for exposed heights ranging from 12 to 15 ft before service limit criteria are exceeded. Walls exceeding this height typically require anchors, deadmen, or internal bracing/rakers.

One common issue overlooked in the design process is how the installation of the sheet piling affects surrounding structures and roadways. Sheet piling is typically installed via vibratory or impact driven methods. Since vibratory methods lend to faster installation, this is the method typically chosen by the contractor. However, vibrations caused by this method verses impact driven methods tend to be more detrimental and may lead to settlement of adjacent soils and subsequent damage to surrounding structures. In these sensitive situations, the Geotechnical Engineer may recommend that a note be placed on the plans notifying the contractor to use impact driven methods for sheet pile installation. With that said, there are scenarios that arise where adjacent settlement or vibrations are not tolerable and a low vibration installation retention system (i.e., drilled) may be better suited. If the sheet piling is to be removed, removal methods must also be considered and addressed appropriately in the design phase.

**Soldier Pile Wall** - Soldier pile walls consist of either drilled or driven structural elements with lagging placed in between each element. Permanent soldier pile walls require a cast-in-place concrete facing while the lagging on temporary walls can consist of wood, precast concrete

panels, or steel sheets. This type of wall is typically considered where hard/dense soils create installation challenges for driven wall systems or where vibrations caused by driven systems cannot be tolerated. Cantilevered wall sections embedded in favorable soils have maximum exposed heights from 12 to 15 ft. Anchors or deadmen are typically required for exposed heights that exceed these values. Permanent soldier pile wall systems require approval by the GSS prior to use on a project.

#### 9.6.4 ANCHORED WALLS

Anchored/braced walls generally consist of vertical structural elements such as soldier piles, sheet pile, or drilled shafts and lateral anchorage elements placed beside or through the vertical structural elements (See [Figure 30](#), b & d). Aside from the manuals noted in Section [9.6](#), the *FHWA GEC 4, Ground Anchors and Anchored Systems* manual provides additional guidance and details into the design and construction of these systems. One item of design that is commonly overlooked when analyzing anchored walls is what earth pressure envelope to use. Per the design references previously provided, the Apparent Earth Pressure envelope should be used for walls that have two or more rows of anchors. Permanent anchored walls require approval by the GSS prior to use on a project.

#### 9.6.5 SOIL NAIL WALLS

Soil nails are reinforcing, passive elements that are drilled and grouted subhorizontally in the ground to support excavations in soil or in soft and weathered rock. General elements of a typical soil nail wall are illustrated in [Figure 31](#). Unlike ground anchors that are post-tensioned, soil nails contribute to the stability of the earth-resisting systems mainly through tension as a result of the deformation of the retained soil or weathered soil mass. Soil nails also transfer loads to the surrounding ground through shear stresses (i.e., bond stresses) along the grout-ground interface. As with any passive system, some movement of the wall must be expected to engage the nails.

Soil nail walls are not specifically addressed by the *AASHTO LRFD Bridge Design Specifications*. Soil nail walls must be designed by the Geotechnical Engineer in accordance with the *FHWA Soil Nail Walls Reference Manual, 2015 (FHWA-IF-14-007)*. Use of this wall system and selected design methodology must be approved by the GSS.

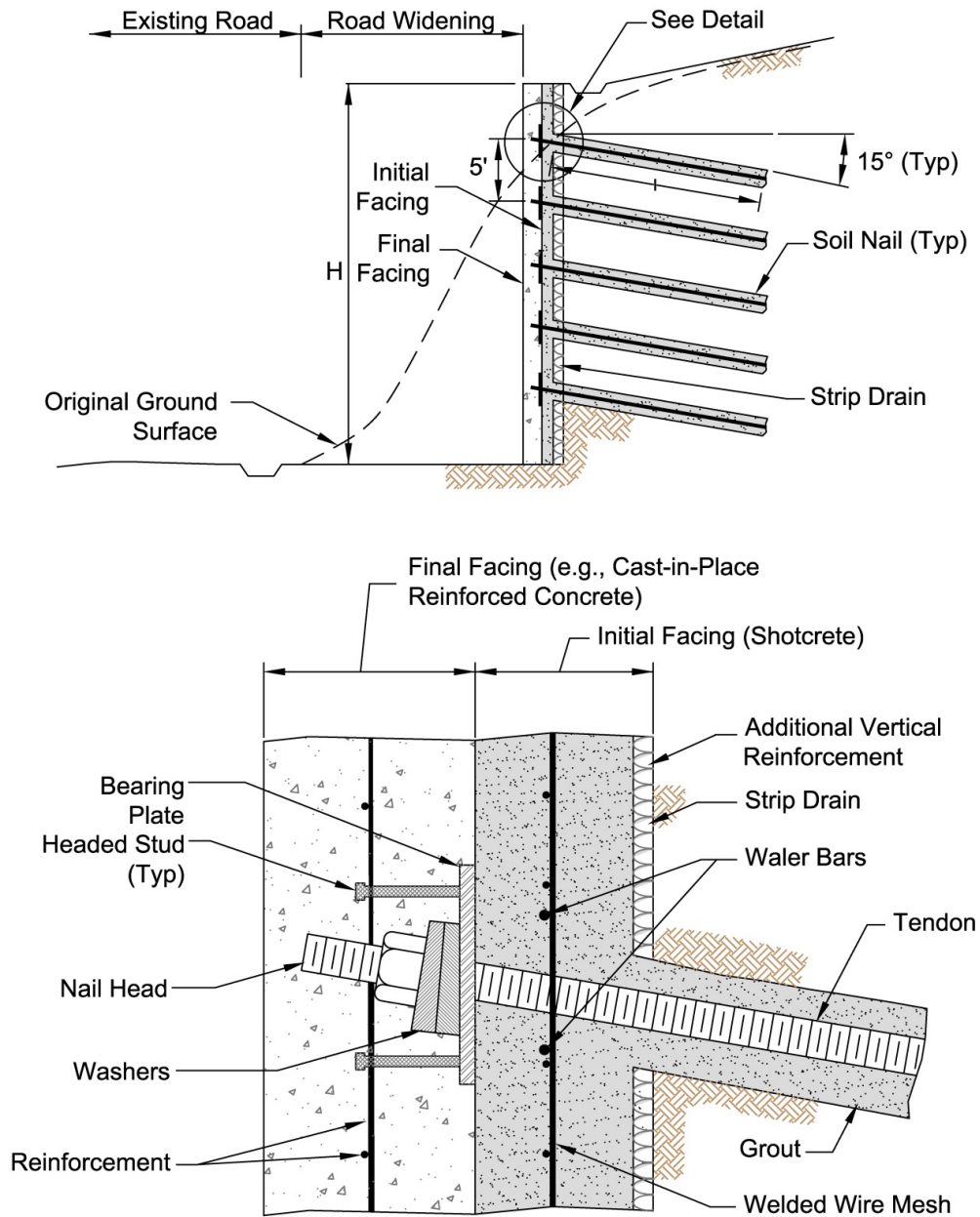

Figure 31: General Cross-Section of a Soil Nail Wall (after Soil Nail Walls Reference Manual, 2015, FHWA-NHI-14-007)

### 9.6.6 TEMPORARY GEOTEXTILE WALL

This section presents design requirements for temporary wrapped-face, geotextile reinforced walls. Temporary geotextile walls must consist of continuous, sheet-type, woven geotextile reinforcement layers constructed alternatively with horizontal layers of compacted sand backfill. The wall face is formed by wrapping each geotextile layer around and back into the overlying lift of backfill.

Temporary geotextile walls are typically used for detours, bridge constructing staging, and roadway widenings. Construction is relatively rapid and does not require specialized labor or equipment. The MDOT *Special Provision for Temporary Geotextile Retaining Wall* limits the height of these walls to 8 ft with a level backslope. Temporary walls higher than this should be designed as a temporary MSE wall in accordance with the *Frequently Used Special Provision for Mechanically Stabilized Earth Retaining Wall System* unless otherwise approved by the GSS.

## 9.7 REINFORCED SOIL SLOPES

Reinforced soil slopes (RSS) are a transitional system between conventional fill slopes and earth retaining wall systems. They are a form of reinforced soil that incorporates planar reinforcing elements in constructed earth-sloped structures with face inclinations of less than 70 degrees (1V:0.36H). Typically, RSSs have slopes ranging from 1V:2H to 1V:1H while conventional fill slopes are 1V:2H or flatter. For MDOT or federally funded projects, reinforced slopes steeper than 1V:1H must be approved by the GSS. *FHWA GEC 11, Design and Construction of Mechanically Stabilized Earth Walls and Reinforced Slopes – Volume I and II*, or most current version of that manual, must be used as the basis for design. Allowable stress design methodology should be used for design of reinforced soil slopes.

### 9.7.1 REINFORCED FILL MATERIALS

Fill materials used to construct the RSS must meet the Structure Backfill requirements as outlined in [Table 12](#) and have a pH between 4.5 and 9. Reinforcement used within the reinforced soil zone must be extensible and consist of either geogrid or geotextile fabric. Inextensible (metallic) reinforcement, when approved by the Geotechnical Services Section, must be connected and used with wire basket facing.

## 9.8 OVERHEAD SIGNS, LUMINAIRES, TRAFFIC SIGNALS, NOISE BARRIER WALLS, CCTV POLES, AND BUILDINGS

All new foundation supports for overhead truss and cantilever signs, strain poles, mast arms, and dynamic message signs must follow design procedures discussed in the *LRFD Specifications for Structural Supports for Highway Signs, Luminaires, and Traffic Signals, 1<sup>st</sup> Edition (2015)*, with 2017 to 2022 Interim Revisions. In addition, MDOT has developed several standardized foundation plans for these types of structures. The standard plan drawings or typical size for drilled shaft foundations are summarized below.

- Strain Poles – See Traffic Signal Strain Pole Foundation Design Table, Sig-Design-153-A & 154-A.
- Mast Arms – See Traffic Signal Mast Arm Pole Foundation Design Table, Sig-Design-284-B
- Overhead Truss Signs – See Non-Cantilever Truss Foundation Chart, Sign-340-C
- Overhead Cantilever Signs – See Cantilever Foundation Chart, Sign-340-C
- Dynamic Message Sign (DMS) – See Special Detail ITS-032-A Foundation Chart. Also see *Special Provision for Dynamic Message Sign, Support Structure and Foundation*.

- High Mast Luminaire – See Standard Plan for Tower Lighting Unit Foundation R-135-A. Note that during the construction submittal review process, the manufacturer must verify the loads from their light tower do not exceed those used in the development of the standard foundation design. If the manufacturer’s loads exceed the design loads, then a site specific design must be prepared by the contractor.
- For noise barrier walls, foundation design must adhere to the Michigan Noise Barrier Wall Design Guidelines document. Typical drilled shaft depths are referenced within the foundation depth tables. Additional design guidance is located in Section 15 (Sound Barriers) of the AASHTO LRFD Bridge Design Specifications.
- Closed Circuit Television Camera (CCTV) Poles – See Standard Plan for Spun Concrete Pole ITS-033-C. The standard foundation is 4 ft diameter by 20 ft embedment – Adequate foundation depth to be verified by Geotechnical Engineer. If additional length is necessary due to poor soils or an unstable bottom, then recommend the use of the add depth pay item described in the Special Provision for Spun Concrete Pole and Drilled Shaft Foundation. Aggregate is typically used for an unstable bottom to provide a firm base when setting the spun pole in the hole. Concrete is used when additional length is needed to meet design requirements. See [Figure 32](#) for a standard foundation design.

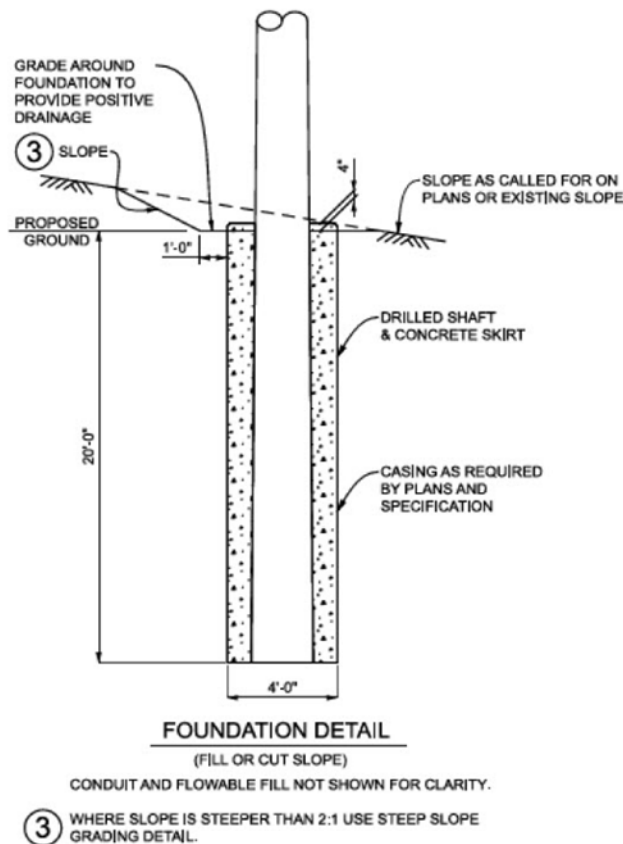

Figure 32: General Cross-Section of a CCTV Foundation

For the structures that have standardized designs, the details of how these were developed are summarized in detailed reports. For subsurface conditions not covered within the design charts, special foundation designs are required by a professional engineer licensed in the State of Michigan. Load combinations can be found in the reports or for the case of cantilever and truss signs, special detail SIGN-300-D and SIGN-360-C summarizes these loads, respectively.

In some locations of the state, shallow bedrock may be present at the structure location. In these situations, it may be prudent to consider using a shallow foundation instead of a drilled shaft foundation. Since the spread footing requires a larger footprint for construction, other items such as adjacent utilities, roadway impacts, and existing right-of-way limits must also be considered when analyzing the use of a spread footing. Standardized spread footing designs for cantilever and truss signs are Sign-330-C, Sign 365-B, Sign-600-B, and Sign-610-B. However, a site-specific design may be required.

*Buildings* – The provisions of this section cover design requirements for small building structures, such as rest areas or maintenance buildings. Typically, buildings are supported on shallow spread footings. Driven piles or drilled shaft foundations may be considered for conditions where soft, compressible soils are present. However, long-term performance of floor slabs, sidewalks, and pavement must be considered.

Foundations must be designed in accordance with the latest Michigan Building Code. This design code specifies that all foundations be designed using allowable stress design methodology. These design methods result in ultimate capacities for the selected foundation type and an appropriate factor of safety must be applied to determine the allowable capacity. The factors of safety noted in Section [9.5](#) should be used in the analysis. Reports and designs for buildings must also address seismic site classification and be sealed by a professional engineer licensed by the State of Michigan.

If septic drain field(s) are needed, local regulations will govern the geotechnical design, including who is qualified to perform the design (i.e., a special license may be required). In general, the soil type, permeability of the soil, and the maximum seasonal groundwater level will need to be assessed for septic system designs.

## SECTION 10 – GEOTECHNICAL REPORTING

### 10.1 GENERAL

Upon completion of the subsurface investigation, lab testing, and analysis, the information must be compiled in a report format that is clear and easy to follow. This report will serve as the permanent record of all geotechnical data known during design of the project, and it may be referenced throughout the design, construction, and service life of the project. As such, it is one of the most important functions of the geotechnical process.

The geotechnical reporting from a high-level view can be characterized under two categories, either roadway (P/PMS Task 3510) or bridge (P/PMS Tasks 3325, 3530, and 3815) related work. These tasks are part of the Program/Project Management System MDOT has developed to map each aspect of the design process. Reporting is one of the work steps outlined in these geotechnical-related tasks. This section provides guidelines for geotechnical reporting.

In general, the first category in the roadway scope of work may consist of obtaining pavement cores and soil borings and then simply providing soil boring data sheets. It can also involve a more complex investigation and reporting process for reconstruction or new road alignment projects, which may include slope stability and settlement analyses. Ancillary structures such as sign foundations, light towers, or strain pole/mast arm foundations may also fall within the more complex roadway projects. In addition, culverts and retaining walls are structures that are typically within the roadway category but may require a level of foundation investigation and reporting similar to a bridge. The second category for geotechnical investigations and reporting involves bridge widenings, new bridges, or bridge reconstruction. Bridge investigations are typically more complex and require more detailed analysis and reporting requirements.

For projects providing only subsurface information, lab testing, or other field-testing information, the guidelines provided in Section [10.2](#) must be adhered to. Note that these reports contain only factual data and are absent of any engineering recommendations or interpretation. For more complex roadway projects where analysis and recommendations are provided and for bridge projects, the reporting guidelines presented in Section [10.3](#) must be followed. For internal MDOT geotechnical reports, the basis of the recommendations is documented in the project file. An internal memo summarizing these items with subsequent detailed recommendations is prepared for final documentation and is included in the project file. All internal memos and geotechnical reports are provided to the MDOT project manager.

Lastly, reports and memos can be prepared at all stages of projects, and they must clearly be identified as “preliminary,” “interim,” or “final” to refer to the stage of the project, not the correspondence. When correspondence at any stage is going through development or review, it is identified as “draft.” Providing a preliminary report and subsequent final report has been very

effective in the typical geotechnical design process and should be used on more complex roadway and bridge projects.

## 10.2 GEOTECHNICAL DATA REPORT

In line with P/PMS Task 3325 (Geotechnical Site Characterization), a Geotechnical Data Report is developed at an early stage of project development. However, many roadway projects falling under Task 3510 also only require providing factual subsurface information such as pavement cores, soil borings, in-situ testing, and lab testing and, therefore, should adhere to these reporting requirements. The contents of this report should include the following.

- Transmittal (typically one page). If desired, provide summary of work performed and subsurface investigation (optional).
- Soil Boring Data Sheet(s) and Individual Boring Logs (as requested in the scope) – absent of any interpretive stratigraphy between soil borings. See Section [10.3.2.12](#) for soil boring reporting requirements.
- Boring Location Plan – Plan must show existing roadway or bridge alignment with stationing. Overlay proposed bridge outline and/or roadway alignment and aerial view as appropriate. Present a north arrow, legend, and appropriate scale.
- Laboratory Testing Results (see Section [10.3.2.13](#) for laboratory testing requirements).
- In-situ Testing Results, if applicable (e.g., pressuremeter, resistivity, dynamic cone penetrometer, ground penetrating radar, falling weight deflectometer, vane shear).

The contents of this report present only factual information. No interpretative data, recommendations, or conclusions are presented in this data report. Examples of typical roadway and bridge soil boring data sheets are illustrated in [Figure 9](#).

### 10.2.1 SOIL BORING NAMING CONVENTION

This section addresses test hole or soil boring naming convention for MDOT projects. To provide clarity for what the soil boring was drilled for, the following naming convention in [Table 18](#) must be used on MDOT projects. If the soil boring will be used for duplicate purposes, then some judgement by the Geotechnical Engineer should be used in determining the boring call out based on the importance of its use on the project. In addition, for more complex projects that have multiple bridges, roads, and/or signs, the structure number or roadway can be placed in parentheses for each soil boring if desired by the project manager. This minimizes confusion if borings have the same number but are for different structures and roads. For instance, a bridge boring has the designation of BB-1(R02). A sign boring has the designation of SB-1(G-233C) and a road boring has the designation of RB-1(I-94 EB). Each soil boring abbreviation naming convention has its own number sequence for that specific project. For instance, road and bridge borings on the same project will have numbering RB-1, RB-2, etc. and BB-1, BB-2, etc.

Table 18: Soil Boring Naming Convention

Soil Boring Abbreviation Naming Convention	Description
RB	Road Boring (Includes borings for road, sewers, water main, roadway cores)
BB	Bridge Boring
CB	Culvert Borings (See Section <a href="#">6.3.1.4</a> for culvert definition and when SPT borings are required)
SB	Sign or Signal Boring (Cantilever, Truss, Gantry, Strain Pole, Mast Arm)
RWB	Retaining Wall Boring
ITB	ITS Boring (dynamic message sign (DMS), closed circuit television camera (CCTV) poles, Road Weather Information System (RWIS) Stations)
SWB	Sound Wall Boring
LB	Light Tower Boring
S	Soundings to determine rock surface or peat/swamp depths
MB	Miscellaneous borings such as swamp check borings, pump station borings, or others

### 10.3 CONTENTS OF GEOTECHNICAL ENGINEERING REPORT

As discussed previously, two categories of reports are typically prepared for MDOT projects: roadway and bridge. Reports for buildings such as rest areas are considered a unique case and reporting guidelines must adhere to Section [10.3.3](#). Geotechnical roadway reports follow P/PMS Task 3510 (Perform Roadway Geotechnical Investigation) while geotechnical bridge reports follow P/PMS Task 3530 (Geotechnical Foundation Engineering Report). Unlike the *Geotechnical Data Report*, some interpretation and opinion in formulating the recommendations are discussed within the *Geotechnical Engineering Report*. However, all interpretations are clearly defined as such. It is important to describe potential problems disclosed by analyses and identify potential feasible solutions. Provide an assessment of cost, risk, and uncertainty associated with each of the possible solutions if requested.

#### 10.3.1 PRELIMINARY GEOTECHNICAL OR LETTER REPORT

Preliminary level geotechnical reports are typically used to provide geotechnical input for the following:

1. Alternative/comparison analyses and/or early geologic concerns (e.g., structure study, initial Task 3325 or 3510 findings, foundation option comparisons, preliminary grading analyses for roadways, stability and settlement concerns of natural slopes and proposed cuts/fills, or grading requirements that may affect right-of-way limits), and

2. rapid assessment of emergency repair needs (e.g., geohazards such as landslides or sinkholes, bridge foundation issues).

For preliminary level design, a reconnaissance of the project site and limited subsurface exploration program are usually conducted, as well as some detailed geotechnical analysis to characterize key elements of the roadway, structure, or geohazard remedial action design. These analyses are adequate to assess potential alternatives and estimate preliminary costs.

Geotechnical projects that consist solely of standard plan structures (such as cantilever and truss signs, strain poles, mast arms, tower lights, dynamic message signs) may use a simple letter report as the final documentation. Where special designs are required for standard plan structures, additional discussion in the analysis and recommendations sections should be provided so that an understanding of the assumptions and design information/analysis used can be documented. Letter reports may also be appropriate when investigating small culverts, sound walls, or where simple roadway projects are solely defined as the scope of work.

The preliminary or letter report should contain the following elements.

1. A general description of the project, project elements, and project background as applicable.
2. A brief summary of the regional and site geology as applicable. This section may be more applicable in bridge foundation reports or landslide reports.
3. A summary of the field exploration conducted, if applicable.
4. A summary of the laboratory testing conducted, if applicable.
5. A description of the project soil and rock conditions. The amount of detail included here will depend on the type of structure/roadway type/scope of work. Soil profiles for key project features such as bridges, major walls, and landslides may need to be developed.
6. A summary of the preliminary or final geotechnical recommendations. Foundation tables, as illustrated in [Figure 33](#) and [Figure 35](#) through [Figure 43](#), may be appropriate when providing recommendations for bridges, walls, or other structure types. For roadway projects, citing stations and associated preliminary grade, drainage, fill/cut slope angles, and subgrade recommendations in those areas provide a concise delivery format. Include discussion of any geologic conditions (e.g., soft soils, unsuitable soils, landslides) that may affect the project design.

Sign No., Span, Location, & Boring No.	Job No. & Control Section	Boring Station & Offset	Shaft Diameter (in.)	Shaft Depth (ft)	Casing
New Truss, 85 ft Exit 69A, SB-1	118729C 41029	141+92 2 ft RT of EOM	48	37	Cased
New Truss, 85 ft Exit 69A, SB-2	118729C 41029	141+97 2 ft LT of EOM	48	37	Cased
G233-C Exit 24 In Advance of Gore, SB-3	132546C 70063	1393+92 8 ft RT of EOM	48	28	Uncased
G234-C Exit 24 at Gore Point, SB-4	132546C 70063	1405+50 12 ft RT of EOM	48	28	Uncased

Figure 33: Geotechnical Report Table of Sign Foundation Recommendations

- Appendices that include any boring logs, soil boring log sheets, boring location plan, laboratory test data obtained, soil profiles developed, any field data obtained, and any photographs.

In larger projects where a two-phased investigation and/or reporting structure is utilized, it may be feasible to use several sections of the preliminary report in the final geotechnical report.

### 10.3.2 FINAL GEOTECHNICAL REPORT

The following outline should be followed in preparing final geotechnical reports for MDOT projects. Each of these sections could be a sentence, a paragraph, or several subsections depending on the scope of work and the purpose of the correspondence.

#### 10.3.2.1 Executive Summary (Optional)

This section is included in project reports with a relatively complicated scope of work. Prepare executive summaries that provide a brief summary of the findings and recommendations. List specific recommendations that result in a deviation from MDOT's general guidelines or construction practices. Typically, this section is one to two pages long.

#### 10.3.2.2 Table of Contents

A detailed table of contents not only provides a general roadmap for the reader but also allows the reader to find areas of interest within the report rather quickly. Each section or subsection of the report must also have page numbers noted within the header or footer. Although not required, linking the table of contents to sections of the report provides added efficiency, especially in larger project reports.

#### 10.3.2.3 Introduction

The introduction describes why the report was prepared (purpose, objective, general scope), what's included in it, how it relates to other reports prepared for the project, and how it's organized. List previous reports, authors, and dates, if applicable. If other

documents or literature were reviewed as part of formulating the report, then adding a subsection or paragraph citing these items should be placed within the introduction.

#### 10.3.2.4 Project Description

This section introduces the project and describes it in detail. Include references to a project or site location map. Discuss the scope of the project (such as roadway widening or bridge replacement) and major features within the project limits (e.g., five-span structure, retaining wall, roadway widening widths, and station limits). Discuss other applicable items of the project such as deep cuts or fills, special drainage considerations, or maintenance of traffic requirements. It must also be stated what design methodology and design manuals were used for the project. In more complex projects involving different manuals and/or methodology, noting these items in the Design Analysis and Recommendations section may be more appropriate.

#### 10.3.2.5 Field Investigation

Provide a summary of the field investigation(s) conducted (e.g., number and type of soil borings, pavement cores, test pits, soundings), if applicable. Note the description of methods and standards used during the field investigation. Also include a description of field instrumentation installed and its purpose. Results of the instrumentation should also be provided or referenced in this section. Indicate date of last calibration and hammer energy ratio in percent for the hammer system(s) used.

#### 10.3.2.6 Laboratory Testing

Discuss types and number of laboratory tests conducted on the soil and rock samples. Include a summary of laboratory testing results as applicable. If deemed significant, discuss the results of these laboratory tests. Appendices are typically used to present compiled data. At a minimum, report the information stated in Section [10.3.2.13](#) on the laboratory test data report sheet.

#### 10.3.2.7 Site Conditions

Discuss the general topography, major drainage features, vegetation, utilities, rock outcrops, notable swamps/marshy areas, and regional and local geology. If appropriate, describe observations in a specific and quantitative way (e.g., 50 ft high, 4V:1H rock slope). For building reports, present appropriate seismic site classification information.

#### 10.3.2.8 Subsurface Conditions

This section provides a summary of the soil, rock, and groundwater conditions at the project site. The soil and rock conditions should be organized into individual stratum and general strength, moisture contents, or other laboratory testing data may be discussed within the stratum descriptions. Groundwater conditions during and after the drilling operations, perched water tables, artesian aquifers, and potential seasonal variations if known are included in this section.

For large roadway projects where the project is divided into stations in the Design Analysis and Recommendations section, discussing the specific subsurface conditions for that area in this section may be more appropriate. Appendices are typically used to present compiled data such as a soil boring data sheet, individual boring logs, monitoring well results, and photographs. See Section [10.3.2.12](#) for soil boring reporting requirements.

#### 10.3.2.9 Design Analysis and Recommendations

*General* - Interpretation of the data is the first phase of analysis and these interpretations should be summarized here. For analysis procedures, refer to Section [9.1](#). Sometimes engineering judgement is all that is needed to develop the recommendations and identify the construction considerations presented later. However, often formal analyses are needed to develop, confirm, and quantify recommendations. Such analyses should be presented in this section. Enough information should be given to perform a cursory review of the recommendations and to identify any significant analysis methods, assumptions, and input parameters (e.g., soil and rock parameters) used. The calculations conducted are included as a deliverable per Section [10.3.4](#).

Design alternatives often need to be evaluated from a geotechnical perspective. The evaluation of pros and cons, risks and costs, etc. is a form of analysis that belongs in this section.

The interpretation of analysis results is the first step in developing design recommendations. It is important that design recommendations for all project features and loading conditions be presented in this section. Recommendations based on the analysis results and/or author experience should be evident. For example, if a recommendation is not consistent with the results of the analysis, an explanation should be provided. Provide concise recommendations directed toward the preferred alternative and presented on a station-by-station, structure/substructure location, and/or feature-by-feature basis. Present recommendations in such a way to be applied to the design and construction specifications. For example, specifying that shoring is needed can be considered a general recommendation but by what means does the designer use to pay for it and by what specification (standard pay item or special provision). Providing more detailed recommendations allows the designer to understand the Geotechnical Engineer's intent for their recommendation. If, in addition to written recommendations, actual design for geotechnical features or certain recommendations require visual sketches for clarity, it may be necessary to include sketches or drawings to convey recommendations or designs as figures. If many are necessary, these should be placed in the Appendix.

If, through this process, the need for further work is identified, it should be presented as a recommendation here. The Geotechnical Engineer must explain the importance of the supplemental work. It should also be mentioned in the Executive Summary section, if applicable.

#### 10.3.2.9.1 Roadway or Subgrade Recommendations

Prepare recommendations related to the design and construction of the roadway that include any remedial measures necessary to complete the project. Provide specific treatment of soft foundation areas, revisions to the preliminary roadway alignment/grade, design of cut/fill slopes, drainage considerations, embankment design related to stability or settlement, construction sequence, instrumentation, field controls, and any other design factors affecting the project. Be specific in the recommendations, noting the extent (station and offset) and depth of all required remedial measures. Likewise, be detailed regarding locations concerning cut and fill slope recommendations.

Prepare recommendations related to the pavement design and subgrade support parameters and construction of the roadway subgrade. Provide specific treatment of soft subgrade. Be specific in the recommendations, noting the extent (station and offset) and depth of all required remedial earthwork measures. Subgrade design values such as the resilient modulus or California Bearing Ratio values with corresponding conversion factors to the subgrade resilient modulus should be placed in this section. The pavement design consists of recommendations on the subbase, base, and pavement (concrete or hot mix asphalt (HMA)) layers. As applicable, the following items should be addressed by the Geotechnical Engineer.

*Alignment Recommendations* – Identify recommended revisions to the horizontal and vertical alignment from the preliminary plans. Include a discussion on why vertical or horizontal alignment revisions are recommended.

*Unsuitable Soils* – Determine areas of unsuitable soils and specify treatment options. For example, subgrade undercutting or peat excavation areas need to be delineated and these areas presented in the report. See Section [9.3.3](#) for determination of these areas and possible mitigation methods.

*Drainage* – Discuss groundwater levels and effect on excavations or construction activities. Provide recommendations to address groundwater concerns that align with the standard specifications or special provisions. Note areas subject to soil erosion and specify soil erosion control measures, if applicable. Items for the Geotechnical Engineer to address should be the pavement section drainage system, cut/fill slope drainage,

storm water or infiltration/detention basins, and surface water flow into the roadway section. See Sections 9.3.3.4 and 9.3.4 for additional discussion on addressing these items. For infiltration/detention basins, the Geotechnical Engineer is responsible for verifying any proposed embankment slopes meet acceptable factors of safety for overall stability (See Section 9.3.7.3.3).

*Roadway Structures* – Provide recommendations for structures related to the roadway corridor including retaining walls, traffic signal poles, overhead highway signs, culverts, sound walls, sewers, etc. Retaining wall reporting guidelines are provided in Section 10.3.2.9.2.

*Stability Analysis Reporting* – Document analysis methods/software used, assumptions made for soil strength parameters and groundwater conditions, selected factors of safety/resistance factors, conclusions from analyses, and recommended methods of mitigation (e.g., regrading, undercutting, ground improvement). Provide stability analysis graphics that summarize the recommendation in the report (see Figure 34). Reference Section 9.3.7.3 for further discussion on the stability analysis.

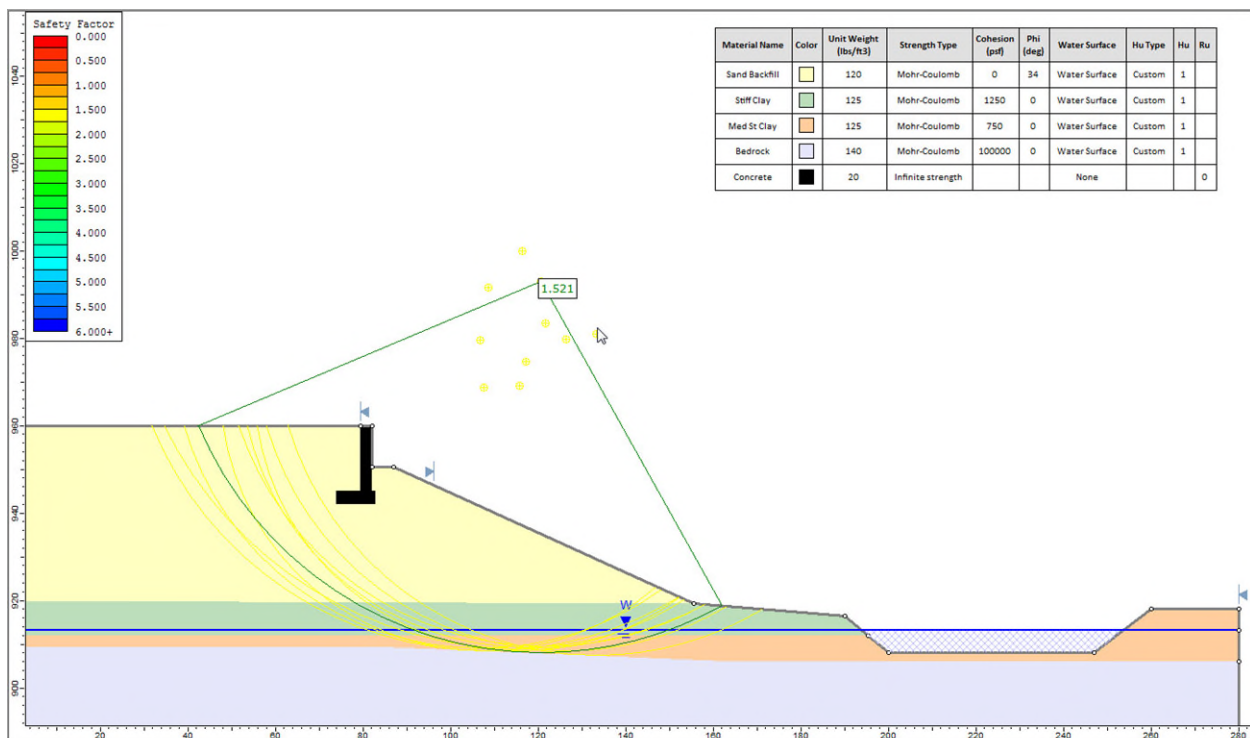

Figure 34: Stability Analysis Summary Graphic

*Settlement* - Document analysis methods/software used, assumptions made for soil parameters (e.g., preconsolidation pressure, compression/recompression index, coefficient of consolidation), groundwater conditions, conclusions from analyses,

recommended mitigation (e.g., over-excavation, use of lightweight fills, wick drains and preloading, staged construction). Reference Section [9.3.7.2](#) for further discussion on the settlement analysis.

#### 10.3.2.9.2 Structure Foundation Recommendations

The Geotechnical Engineer must provide definitive recommendations on the structure or geotechnical aspects that are consistent with the responsibilities discussed in Section 9. Note suitable shallow or deep foundation types analyzed and provide final recommendations on selected option. The Geotechnical Engineer must provide a summary of the design assumptions including, but not limited to, information about the design methodologies, axial and horizontal structure loading information (usually obtained from structural engineer), embankment fill heights, type of embankment or structure backfill required, side slope and end slope angles, and other pertinent information as applicable or requested by the GSS. At a minimum, the Geotechnical Engineer must address the following.

*Spread Footing* – Note settlement analyses results (both total and differential) and provide recommendations on the bearing resistances for the different limit states, associated resistance factors, and cohesion and/or drained friction values for sliding analyses. Recommend minimum footing size and embedment depth. Provide a chart as needed indicating bearing resistance available based on effective footing sizes. In addition, include a note that the region soils engineer must inspect the footing excavation. An example summary table and chart are provided below in [Figure 35](#) and [Figure 36](#).

Design Parameter	Abutment A	Pier 1	Abutment B
Bottom of Footing – ft	607.8	608.3	609.9
Proposed Effective Footing Width - ft	12	9	12
<b>Strength Limit State Design</b>			
Nominal Bearing Resistance ( $q_n$ ) - psf	10,200	10,200	10,200
Resistance Factor ( $\phi_b$ )	0.45	0.45	0.45
Factored Bearing Resistance ( $q_R$ ) - psf	4,600	4,600	4,600
<b>Service Limit State Design</b>			
Nominal Bearing Resistance ( $q_n$ ) - psf	2,750	2,750	2,750
Estimated Total Settlement – in.	<1.5	<1.5	<1.5
Differential Settlement – in.	≤ 0.5		
Resistance Factor for Sliding ( $\phi_{\text{sliding}}$ )	0.85	0.85	0.85

Figure 35: Spread Footing Design Summary Table

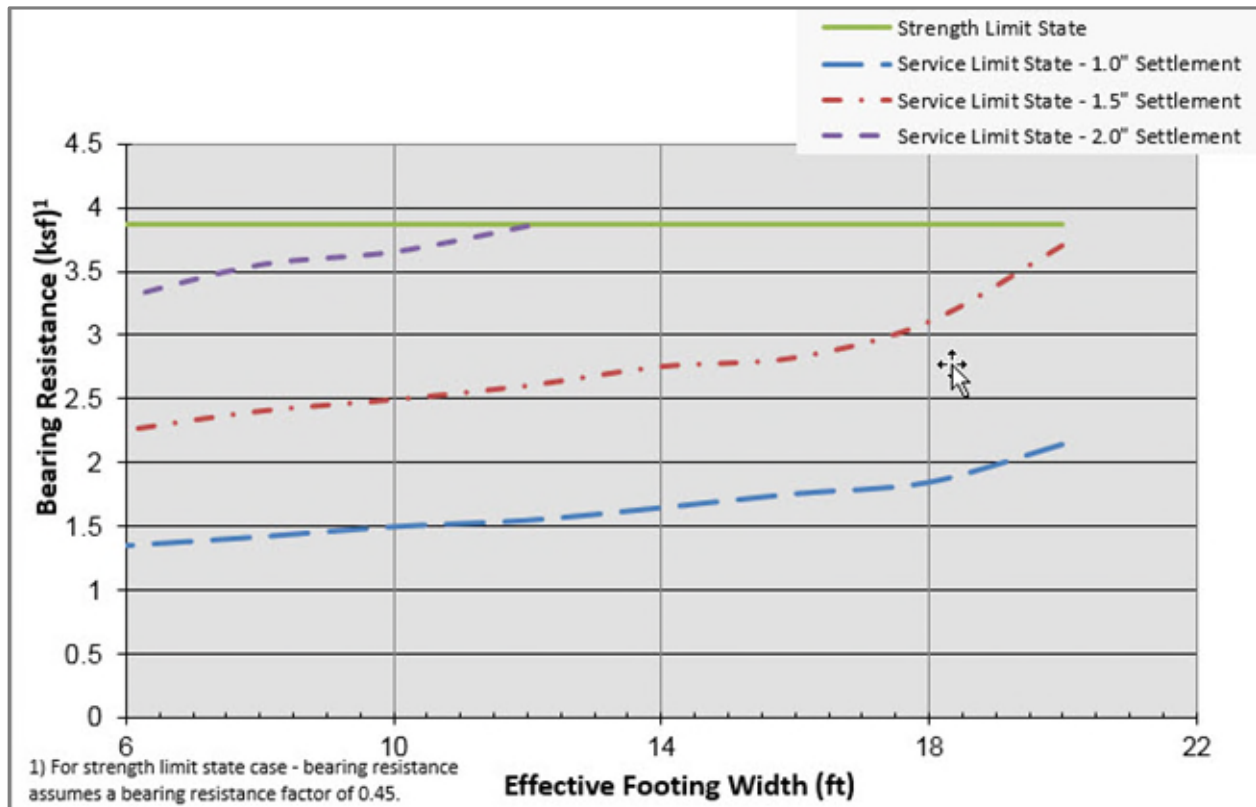

Figure 36: Spread Footing Bearing Resistance Summary Chart

*Driven Steel Piles* – The following items must be addressed as applicable in this section. [Figure 37](#) provides an example table summarizing several of these items.

1. Suitable pile type(s) and reasons for design selection and exclusion as appropriate.
2. Provide estimate or design pile tip elevation. Note minimum pile tip elevation.
3. Recommend nominal pile driving resistance, factored nominal bearing resistance, and corresponding resistance factors. Account for scour or downdrag when providing these recommendations.
4. Present recommendation on lateral pile resistance and corresponding deflections.
5. Recommend minimum pile spacing and shadowing effects if applicable.
6. Estimate pile settlement and pile group settlement as applicable. Comment on differential settlement between substructures.
7. Consider effects of lateral squeeze and comment as applicable.
8. Recommend locations and number of test piles.
9. Provide guidance to the design engineer on recommended special provisions for pile installation or quality control measures.

10. Recommend appropriate type of quality control/quality assurance during installation (e.g., Federal Highway Administration modified Gates formula, dynamic testing, load test).
11. Make recommendation on whether steel pile points are required.

Design Parameter	Abut. A	Pier 1	Pier 2	Abut. B
Pile Section	HP 14x89	HP 14x89	HP 14x89	HP 14x89
Bottom of Footing/Tremie Elevation	942.0	910.0/908.5	914.0/913.5	933.0
Scour Elevation – 100/500 Year	N/A	902.0/905.0	911.0/910.0	N/A
Minimum Pile Tip Elevation	912.0	890.0	894.0	908.0
Estimated Pile Tip Elevation	904.0	866.0	873.0	902.0
Nominal Pile Driving Resistance - $R_{ndr}$ (kips)	600	600	600	600
Side Resistance in Scourable Zone - $R_s$ (kips) <sup>1</sup>	0	20	0	0
Nominal Pile Bearing Resistance – $R_n$ (kips)	600	580	600	600
Resistance Factor for Driven Piles - $\phi_{dyn}$	0.5	0.5	0.5	0.5
Factored Nominal Bearing Resistance- $\phi_{dyn} * R_n$ (kips)	300	290	300	300
Nominal Horizontal Geotechnical Resistance with 0.5 in. of Deflection (kips)	12	12	12	12
Resistance Factor for Horizontal Pile Resistance	1.0	1.0	1.0	1.0

<sup>1</sup> Nominal side resistance loss due to 100-year/500-year scour event.

Figure 37: Example of Driven Pile Analysis Summary Table

*Micropiles* – When micropiles are recommended for use on a project, provide the following information. [Figure 38](#) and [Figure 39](#) illustrates example tables summarizing many of these items.

1. Note recommended casing size, casing thickness, reinforcing bar diameter, and minimum bond zone diameter. Recommend grout compressive strength and steel yield stress for the casing and bar design.
2. Recommend micropile tip elevation and bottom of casing depth/elevation.
3. Provide recommendations on nominal axial compression resistance, factored nominal axial compression resistance, and associated resistance factors. Account for scour and/or downdrag when providing these recommendations.
4. Provide recommendations on lateral micropile resistance and corresponding deflections.
5. Recommend minimum micropile spacing and shadowing effects if applicable
6. Estimate micropile settlement and micropile group settlement as applicable. Comment on differential settlement between substructures.

7. Consider effects of lateral squeeze and comment as applicable.
8. Recommend locations and number of verification and proof load tests.
9. Provide guidance to the design engineer on recommended special provisions for micropile installation and quality control measures.

Design Parameter	Pier 1	Pier 2	Pier 3
Minimum Micropile Bond Zone Diameter (in.)	9.6	9.6	9.6
Minimum Casing Outside Diameter – Min. Thickness (in.)	9.625 x 0.5	9.625 x 0.5	9.625 x 0.5
Reinforcing Bar Diameter	No. 18	No. 18	No. 18
Bottom of Footing/Tremie Elevation (ft)	907.0/904.5	904.0/901.0	910.5/908.5
Scour Elevation – 100/500-Year (ft)	893.0/895.0	893.0/895.0	911.0/911.0
Bottom of Permanent Casing Elevation (ft)	889.0	889.0	896.5
Micropile Tip Elevation (ft)	865.0	864.0	870.5
Nominal Axial Compression Resistance - $R_n$ (kips)	430	430	430
Resistance Factor for Micropiles - $\phi_{stat}$	0.7	0.7	0.7
Factored Nominal Axial Resistance - $\phi_{stat} \cdot R_n$ (kips)	300	300	300
Nominal Horizontal Geotechnical Resistance with 0.5 in. of Deflection (kips)	12.0	12.0	12.0
Resistance Factor for Horizontal Micropile Resistance	1.0	1.0	1.0

Figure 38: Example of Micropile Analysis Summary Table

Design Parameter	Design Assumptions and Results
Maximum Factored Vertical Load (kips)	300
Maximum Factored Lateral Load (kips)	12
Maximum Factored Moment (ft-kips)	0
Size of reinforcing bar	No. 18 Bar
Casing Size (in.)	9.625 O.D., 0.5 Wall Thickness
Grout Compressive Strength (psi)	5,000
Calculated Maximum Shear Force (kips)	12.0
Calculated Maximum Moment (in-kip)	603.54
Point of Fixity (ft)	Elev. 895.2
Calculated Depth of Maximum Shear (ft)	Top of Micropile, Elev. 907.0
Calculated Depth of Maximum Moment (ft)	Top of Micropile, Elev. 907.0

Figure 39: Example of Micropile Lateral Analysis Summary Table

*Drilled Shafts* – When drilled shafts are recommended for use on a project, provide the following information. [Figure 40](#) and [Figure 41](#) illustrate example tables summarizing many of these items.

1. Note recommended shaft diameter, bottom of drilled shaft elevation, and casing size and type. For casing type, specify if permanent or temporary, left-in-place casing will be required for constructability.
2. Recommend bottom of casing depth/elevation, if applicable.
3. Provide recommendation on nominal axial shaft resistance, factored nominal axial shaft resistance, and associated resistance factors. Account for scour and/or downdrag when providing these recommendations.
4. Provide recommendations on lateral shaft resistance and corresponding deflections. Provide maximum internal moment and shear forces and point of fixity based on the lateral pile analysis.
5. Estimate shaft settlement and shaft group settlement as applicable. Comment on differential settlement between substructures.
6. Consider effects of lateral squeeze and comment as applicable.
7. Recommend minimum shaft spacing and group/shadowing effects on capacity if applicable.
8. Provide guidance to the design engineer on recommended special provisions for shaft installation and quality control measures.

Design Parameter	Abutment A	Pier 1	Abutment B
Drilled Shaft, Standard Diameter (in)	60	60	60
Drilled Shaft, Rock Diameter (in)	54	54	54
Design Scour Elevation – 100/500 Year (ft)	584.0/582.0	584.0/583.0	590.0/588.0
Bottom of Abut. Wall or Pile Cap Elevation (ft)	621.0	624.1	622.0
Casing Type <sup>1</sup>	Temp, LIP	Temp, LIP	Temp, LIP
Top / Bottom of Casing Elevation (ft)	621.0 / 580.0	624.1 / 582.0	622.0 / 582.0
Top / Bottom of Drilled Shaft, Standard Elevation (ft)	621.0 / 580.0	624.1 / 582.0	622.0 / 582.0
Top / Bottom of Drilled Shaft, Rock Elevation (ft)	580.0 / 557.0	582.0 / 566.0	582.0 / 567.0
Factored Axial Shaft Resistance (kips)	895	895	895

<sup>1</sup>Temp, LIP – Temporary Left-in-Place.

Figure 40: Example of Drilled Shaft Foundation Analysis/Recommendations Summary Table

Design Parameter	Design Assumptions and Results
Maximum Unfactored Vertical Load (kips)	586.9
Maximum Unfactored Lateral Load (kips)	45.5
Maximum Unfactored Moment (ft-kips)	2,133
Size and Number of Reinforcing Bars (1% of rock socket diameter)	22 – No. 9 Bars
Concrete Compressive Strength (psi)	3,500
Calculated Deflection (in)	2.0
Calculated Maximum Shear Force (kips)	587.9
Calculated Maximum Moment (in-kip)	25,261
Point of Fixity (ft) <sup>1</sup>	44
Calculated Depth of Maximum Shear (ft) <sup>1</sup>	44.6
Calculated Depth of Maximum Moment (ft) <sup>1</sup>	41.5

<sup>1</sup>Depths are referenced from Bottom of Abutment Wall or Bottom of Pile Cap as noted in Figure 37.

Figure 41: Example of Drilled Shaft Lateral Analysis Summary Table

*Retaining Walls* – When retaining walls are recommended for use on a project, provide the following information. Depending on the type of wall and foundation support option selected, use the reporting guidelines in the previous sections for that foundation type.

1. Discuss retaining wall types considered and reasons for design recommendation and exclusions as appropriate.
2. Provide factored/nominal bearing resistance or alternate foundation recommendations as applicable.
3. Report on results of external stability analyses including overall stability and lateral squeeze as applicable.
4. Include discussion on anchor/deadman type, size, length, and capacity as applicable.
5. Discuss estimated total and differential settlement.
6. For MSE walls, note recommendation on minimum strap length to meet modes of failure analyzed during the external stability analyses.
7. Discuss wall drainage and backfill requirements.
8. Discuss corrosion protection for buried steel elements.
9. Document the testing and instrumentation requirements.
10. For permanent sheet pile walls, document the design assumptions and recommendations. See [Figure 42: Example of Permanent Tieback Sheet Pile Wall Design Summary Table](#) and [Figure 43: Example of Permanent Cantilever Sheet Pile Wall Design Summary Table](#).

Design Criteria	Sheet Pile Wall
Design Top of Sheet Pile Wall Elevation (ft)	714-716
Design Front of Wall Height (Exposed Height)	Max 19.5 ft
Waler Elevation (ft)	712.0
Design Live Load Surcharge (psf)	360
Backslope Angle (degrees from horizontal)	26.6 – Broken Slope
Sheeting and Bracing Requirements	
Recommended Sheet Pile Section – ASTM A572, Grade 50	PZC 26
Required Minimum Section Modulus of Sheet Piling (in <sup>3</sup> /ft)	48.4
Required Sheet Pile Length (ft)	42
Recommended Wale Section – ASTM A572, Grade 50	2 – C9 x 20
Anchor Plate Dimensions – AASHTO M270, Grade 50, (in)	8.0 x 8.0 x 2.0
Wale Load – Unfactored Horizontal Earth Pressure (kips/ft)	10.42
Wale Load – Unfactored Live Load Surcharge (kips/ft)	4.59
Recommended Threaded Tie Bar – ASTM A615, Grade 75 (in)	#18 Bar – 2.25" Dia.
Maximum Tie Bar Spacing (ft)	6.5
Maximum Tie Bar Spacing from End of Wall (ft)	3.4

Figure 42: Example of Permanent Tieback Sheet Pile Wall Design Summary Table

Design Criteria	Sheet Pile Wall
Design Top of Wall Elevation (ft)	714 - 716
Design Front (Exposed) Wall Height (ft)	Max 9
Design Live Load Surcharge (psf)	360
Backslope Angle (degrees from horizontal)	26.6 - Broken
Frontslope Angle (degrees from horizontal)	18.4
Sheeting Requirements	
Recommended Sheet Pile Section – ASTM A572, Grade 50	PZC 26
Required Minimum Section Modulus of Sheet Piling (in <sup>3</sup> /ft)	48.4
Required Sheet Pile Length (ft)	31

Figure 43: Example of Permanent Cantilever Sheet Pile Wall Design Summary Table

#### 10.3.2.10 Construction Considerations

Construction considerations for either roadway or structure projects are a key component of the geotechnical report and must be addressed by the Geotechnical Engineer. Considerations mentioned in this section should assist the designer to identify potential issues and provide options and/or recommendations to address that issue. The following bullets provide discussion topics to be considered and addressed as applicable in this section.

- *Groundwater/Surface Water* – When groundwater or surface water (e.g., stream, river, lake) is encountered during a field investigation, methods to control the water if excavating into it should be addressed. If surface water is also an issue in a culvert replacement, how will the surface water be maintained during construction. Pay items such as steel sheet piling, cofferdams, construction dam and bypass pumping should be recommended by the Geotechnical Engineer if needed to facilitate construction of the structure or roadway. Several standard pay items or special provisions exist to address many of these issues.

When sites encounter artesian conditions, which are penetrated by excavation or foundation systems, contract language and appropriate pay items must be developed for each site on a case-by-case basis. Questions regarding how to address this type of subsurface condition should be directed to the Geotechnical Services Section.

- *Cut Slopes* – Recommended maximum allowable angle of repose to facilitate construction should be specified in this section. These recommendations should be in accordance with Michigan Occupational Safety and Health Administration (MIOSHA) rules.
- *Bridges, Culverts, Retaining Walls, Overhead Sign Structures and other Shallow Foundation Supported Structures* – If soil undercutting is required as part of the recommendations, then provide recommendation on the vertical and horizontal limits and material used for replacement.
- *Maintenance of Traffic* – Whether the project will have traffic detoured or constructed part-width, it should be reviewed by the Geotechnical Engineer. Many part-width construction scenarios involving excavations require shoring of some type. In consideration of this scenario, the Geotechnical Engineer should provide recommendations on the type of shoring system to be used and whether it should be left in place or removed. For instance, during a bridge replacement project, stageline sheeting installed during the second phase may need to be left in place to minimize the risk of subsidence of the adjacent roadway.
- *Inspections* – The Geotechnical Engineer should provide guidance to the design team whether inspection of the roadway subgrade or foundation/retaining wall excavations is required and specify what plan notes are required.
- *Vibrations* – Sheet pile and driven pile installation create vibrations that may be detrimental to adjacent roadways or structures. Settlement or structural damage of adjacent roadways, structures, or utilities can occur in certain situations. The Geotechnical Engineer should evaluate if vibrations are anticipated to be a potential issue based on installation methods being used, distance from installation source, and purpose or condition of the existing roadway or structure. Potential mitigation measures that may need to be specified are as follows:
  - Requiring the contractor to impact drive the steel sheet piling versus vibrating it into place,
  - Performing vibration and/or settlement monitoring of structures or utilities, or
  - Using a low vibration foundation element or shoring option.

#### 10.3.2.11 Attached Figures

Provide a site location map, soil boring location plan, and any soil profile drawings or cross-sections developed when interpreting the geologic conditions of the site. A U.S. Geological Survey topographic quadrangle map should be provided either as the site location map or other separate figure. See Section [10.2](#) for reporting details on the soil boring location plan.

#### 10.3.2.12 Appendix A

Place the soil boring data sheet(s) and individual soil boring logs in Appendix A. Develop these logs by integrating the driller's field logs, laboratory test data, in-situ test data as applicable, and visual descriptions. Include the following information on the soil boring data sheets and individual soil boring logs:

##### 10.3.2.12.1 Soil Boring Heading

- Project Number (123456PES, PE, EPE, etc.)
- Project Name (M-24 over the Iosco River, M-24 Realignment)
- Bridge Identification (B02 of 52055)
- Station, Offset, and Surface Elevation
- Coordinates (see Section [6.2.3](#))
- Names of Drilling, Sampling and Logging Firm(s) and Personnel
- Name/Type of Drill Rig
- Methods of Drilling and Sampling
- Hammer Efficiency
- Date Started and Date Completed

##### 10.3.2.12.2 Soil Boring Information

- A depth and elevation scale
- Indication of stratum change
- Description of material in each stratum per MDOT material description guidelines
- Depth of bottom of boring
- Depth of boulders and cobbles, if encountered
- Static and free water level observations
- Caving depth
- Artesian water height of rise
- Blow-back of sand during drilling and height
- Cavities or other unusual conditions
- Borehole backfilling or sealing methods
- Types and depths of instrumentation installed
- Depth interval represented by sample
- Sample number and type

- Percent recovery for each sample
- Blow counts as recorded in the field for each 6 inches of drive for split spoon samples
- Strength testing data (hand penetrometer, unconfined compression test, etc.)
- Moisture content
- Liquid limit, plastic limit, plasticity index
- Rock core run percent recovery
- Rock core run Rock Quality Designation (RQD)
- Rock compressive strength test results

#### 10.3.2.13 Appendix B

Include lab testing report sheets, in-situ testing results, and photographs, as applicable. For the laboratory tests listed below, include these items on the test reports.

##### 10.3.2.13.1 Unconfined Compression Test

Provide a report of the unconfined compression test according to ASTM D2166 and include the following.

- *Heading* – Include project identification, boring number, station and offset (if available), northing and easting coordinates, depth interval of sample, and sample number in the report heading.
- *Graphical Data* – Show a graph of the stress-strain relationship. Present an interpretation of the results including the maximum stress at the corresponding strain.
- *Specimen Data* – Show specimen data including dimensions of specimen, wet unit weight and/or dry unit weight, moisture content, liquid limit, plastic limit, description of material, and failure sketch to scaled size disclosing major crack patterns.

##### 10.3.2.13.2 Consolidation Test

Provide a report of the consolidation test according to ASTM D2435 and include the following information.

- *Heading* – Include Heading information from Section [10.3.2.13.1](#).
- *Graphical Data* – Provide a graph illustrating the pressure-void ratio relationship with void ratio plotted to arithmetic scale and pressure plotted to logarithmic scale for both the loading and rebound.

Provide time-consolidation curves for each loading of the specimen on supplemental sheets. Show deformation readings to the nearest 0.0001 inch, plotted to an arithmetic scale, with time in minutes plotted to a logarithmic scale or square root-of-time plotted to an arithmetic scale. Indicate the pressure for each

curve. Show the entire curve of any one loading but no more than two loadings on a single sheet. Use abbreviated heading information on each sheet.

Show the coefficient of consolidation for loadings that are used in the analyses. Present in either graphical or tabular form.

- *Test Data* – For each consolidation test, include diameter, specific gravity, liquid limit, plastic limit, description of the soil, and particle-size analysis of samples. Also include the initial and final readings for thickness, moisture content, wet and dry unit weight, and void ratio.

#### 10.3.2.13.3 Direct Shear Test

Provide a report for the direct shear test according to ASTM D 3080 and include the following information.

- *Heading* - Include Heading information from Section [10.3.2.13.1](#).
- *Graphical Data* – Present normal pressure versus shear stress and shear displacement versus shear stress in graphical form, established on the basis of not less than three normal loads.
- *Test Data* – For each of the three specimens, include initial (wet) weight and volume of the specimen, wet unit weight, and moisture content. In addition, include the following information on one or more of the test specimens: liquid limit, plasticity index, and particle-size analysis (see Section [10.3.2.13.5](#)). Record a description of the material and the type of test. Provide an interpretation of the cohesion and friction angle from the data.

#### 10.3.2.13.4 Triaxial Compression Test

Provide a report of the triaxial compression test according to ASTM D2850 or D4767 and provide the following.

- *Heading* - Include Heading information from Section [10.3.2.13.1](#).
- *Graphical Data* - For each test specimen, show the relationship for the vertical stress versus strain and the pore pressure versus strain in graphical form. For the appropriate range of stress conditions selected, show the Mohr's stress circles based on total and effective stress. Provide an interpretation of the cohesion and friction angle from the data.
- *Test Data* - For each specimen, include moisture content, wet and dry unit weights, liquid limit, plastic limit, particle-size analysis (see Section [10.3.2.13.5](#)), chamber pressures, and failure sketches to a scaled size showing front and side views disclosing major crack patterns. Record a description of the material and the type of triaxial test (e.g., UU, CU, CD).

#### 10.3.2.13.5 Particle Size Analysis

Provide a report of the particle size analysis according to ASTM D7928 and provide the following information.

- *Heading* - Include Heading information from Section [10.3.2.13.1](#).
- *Graphical Data* - For each tested sample, show the relationship for grain size (mm) and percent passing by weight in graphical form. The grain size in millimeters must be plotted in logarithmic scale on the x-axis while the percent passing by weight is plotted in arithmetic scale on the y-axis. Provide sieve sizes on the graph showing the material breaks or at divisions within the same material type.
- *Test Data* - Provide the unified soil classification description, natural moisture content, plastic limit, liquid limit, plasticity index, summary of the percent gravel, sand and silt/clay size particles ( $D_{60}$ ,  $D_{30}$ ,  $D_{10}$ ), coefficient of curvature ( $C_c$ ), and coefficient of uniformity ( $C_u$ ).

#### 10.3.2.14 Other Appendices

Add and label other appendices as needed.

### 10.3.3 REPORTS FOR BUILDINGS

Geotechnical reports, which provide geotechnical recommendations for proposed buildings, should follow the letter report outline presented in Section [10.3.1](#). In addition to the reporting sections discussed in Section [10.3.1](#), recommendations and discussion pertaining specifically to building design and construction should be presented in this report. For example, sections pertaining to site grading, building foundation, and the floor slab should be included as part of this report. As required by the Michigan Building Code, the report must be signed and sealed by a professional engineer licensed by the State of Michigan.

### 10.3.4 CALCULATIONS

As part of the final deliverable, a calculation package of the analysis must be provided during submittal of the final geotechnical report or shortly after the final report submittal and placed in the design file. However, at any time within the design phase of the project, calculations of the analysis must be provided by the consultant if requested by MDOT. The package is not part of the geotechnical report but is a separate deliverable and must have a title sheet and table of contents. The table of contents must list the different types of analyses performed and corresponding page numbers. Add narrative throughout the calculations that describes the basis of the design recommendations from the calculations or other considerations. If using spreadsheets, provide detailed hand calculations for one example to demonstrate the accuracy of the spreadsheet. A thorough quality assurance check of the package must be performed with the following clearly noted on each page: date, initials of the person doing the calculations, and the reviewer. The calculation package must be submitted in portable document format (PDF).

## 10.4 ADDENDUM REPORTS

If the project design is altered as project development advances, the geotechnical recommendations may have to be modified from those presented in the original geotechnical memorandum or report. When the project approaches the final design stage, the Geotechnical Engineer should determine if the geotechnical report needs to be revised to reflect modified assumptions and recommendations incorporated in the final design plans.

## 10.5 SPECIAL PROVISION

A special provision is a document that details directions, provisions, and requirements for the work to be performed. Many times, these are needed to provide guidance to the construction staff and contractor. Existing special provisions can be found on the MDOT website at this [link](#). If modification to existing special provisions are required, then resubmittal, review, and approval is required prior to use on an MDOT project. Development of new special provisions must adhere to the guidelines presented in the *Road Design Manual*, Section 11.

If you require assistance accessing this information or require it in an alternative format, contact the Michigan Department of Transportation's (MDOT) Americans with Disabilities Act (ADA) coordinator at [Michigan.gov/MDOT-ADA](https://Michigan.gov/MDOT-ADA).

## SECTION 11 – REFERENCES

### 11.1 REFERENCES

AASHTO, 1993. *AASHTO Guide for Design of Pavement Structures*.

AASHTO, 2002. *Standard Specifications for Highway Bridges*, 17<sup>th</sup> Edition.

AASHTO, 2017. *AASHTO LRFD Bridge Design Specifications*.

AASHTO, Miscellaneous Standards via ASTM Compass Web Portal, [www.compass.astm.org](http://www.compass.astm.org).

Abramson, L.W., T.S. Lee, S. Sharma, G.M. Boyce, *Slope Stability and Stabilization Methods*, 1996, John Wiley & Sons, Inc., New York .

American Association of State Highway and Transportation Officials, 2012 with Interims. *AASHTO Load Resistance Factor Design (LRFD) Bridge Design Specifications*.

American Society for Testing and Materials International (ASTM International), Miscellaneous Standards via ASTM Compass Web Portal, [www.compass.astm.org](http://www.compass.astm.org).

Das, B.M., 1999, *Principles of Foundation Engineering*, Fourth Edition, Brooks/Cole Publishing Company, California.

Department of the Navy, Naval Facilities Engineering Command, 1982. *Soil Mechanics – Design Manual 7.1*, Publication No. NAVFAC DM-7.1, Alexandria, Virginia.

Department of the Navy, Naval Facilities Engineering Command, 1986. *Foundations and Earth Structures 7.2*, Publication No. NAVFAC DM-7.2, Alexandria, Virginia.

E.C. Novak, Jr., May 1974. *An Investigation of the Definition of Frost Heave Textured Material*, Research Report No: R-914.

Gilbert Baladi, Pegah Rajaei, December 10, 2014. *Predictive Modeling of Freezing and Thawing of Frost-susceptible Soils*.

Holtz, R.D, Kovacs, W.D., 1981. *An Introduction to Geotechnical Engineering*, Prentice-Hall Inc., New Jersey.

Holtz, R.D., Christopher, B.R., and Berg, R.R., 2008. *Geosynthetic Design and Construction Guidelines*, FHWA NHI-07-092.

Lukas, R.G. (1995), Geotechnical Engineering Circular No. 1 Dynamic Compaction, Publication No. FHWA SA-95-037.

- Michigan Department of Environmental Quality, Water Bureau, March 2005, *Flowing Well Handbook*.
- Michigan Department of State Highways, January 1970. *Field Manual of Soil Engineering – Fifth Edition*.
- Michigan Department of Transportation, April 6, 2009. *Uniform Field Soil Classification System (Modified Unified Description)*.
- Michigan Department of Transportation, *Bridge Design Guides*. Michigan Department of Transportation, *Bridge Design Manual*.
- Michigan Department of Transportation, Construction and Technology Support Area, Geotechnical Services Unit, March 2004. *Geotechnical Investigation and Analysis Requirements for Structures*.
- Michigan Department of Transportation, Materials and Technology Division, December 1987. *Joint Faulting in Concrete Pavements*, Materials and Technology Engineering and Science, Issue No. 14.
- Michigan Department of Transportation, Materials and Technology Division, January 1988, *Drainage – The Solution to the Three Problems Critical to Pavement Performance*, Materials and Technology Engineering and Science, Issue No. 15.
- Michigan Department of Transportation, *Michigan DOT User Guide for Mechanistic-Empirical Pavement Design*, Interim Edition, November 2017.
- Michigan Department of Transportation, *Road Design Manual*.
- Michigan Department of Transportation, Tetra Tech MPS, *Drainage Manual*, January 2006.
- Transportation Research Board, National Research Council, 1996, *Landslides – Investigation and Mitigation*, Special Report 247.
- U.S. Department of Transportation, Federal Highway Administration, April 2002. *Geotechnical Engineering Circular No. 5 – Evaluation of Soil and Rock Properties*, Publication No. FHWA-IF-02-034.
- U.S. Department of Transportation, Federal Highway Administration, November 1997. *Subsurface Investigations*, Publication No. FHWA-IF-97-021.
- U.S. Department of Transportation, Federal Highway Administration, May 2002. *Subsurface Investigations – Geotechnical Site Characterization*, Publication No. FHWA-NHI-01-031.

- U.S. Department of Transportation, Federal Highway Administration, Washington D.C., June 2010, *Geotechnical Aspects of Pavements Reference Manual*, Publication No. FHWA NHI-10-092.
- U.S. Department of Transportation, Federal Highway Administration, Washington D.C., 2006. *Soils and Foundations – Volume I and II*, FHWA Publication No. FHWA-NHI-06-088.
- U.S. Department of Transportation, Federal Highway Administration, Washington D.C., 2008. *Earth Retaining Structures*, Publication No. FHWA-NHI-07-071.
- U.S. Department of Transportation, Federal Highway Administration, Washington D.C., 2003. *Soil Nail Walls*, Geotechnical Engineering Circular No. 7, Publication No. FHWA-IF-03-017.
- U.S. Department of Transportation, Federal Highway Administration, Washington D.C., 2006. *Design and Construction of Driven Pile Foundations – Volume I and II*, Publication No. FHWA-NHI-05-042.
- U.S. Department of Transportation, Federal Highway Administration, Washington D.C., 2005. *Micropile Design and Construction*, Publication No. FHWA-NHI-05-039.
- U.S. Department of Transportation, Federal Highway Administration, Washington D.C., 2010. *Drilled Shafts: Construction Procedures and LRFD Design Methods*, Geotechnical Engineering Circular No. 10, Publication No. FHWA-NHI-10-016.
- U.S. Department of Transportation, Federal Highway Administration, Washington D.C., 1999. *Drilled Shafts: Construction Procedures and Design Methods*, Publication No. FHWA-IF-99-025.
- U.S. Department of Transportation, Federal Highway Administration, Washington D.C., 2001. *Shallow Foundations*, Publication No. FHWA-NHI-01-023.
- U.S. Department of Transportation, Federal Highway Administration, Washington D.C., September 2005. *Soil Slope and Embankment Design*, Publication No. FHWA-NHI-05-123 and 124.
- U.S. Department of Transportation, Federal Highway Administration, Washington D.C., March 2012. *Design and Construction of Mechanically Stabilized Earth Walls and Reinforced Slopes – Volume I and II*, Publication No. FHWA-NHI-09-24 and 25.
- U.S. Department of Transportation, Federal Highway Administration, Washington D.C., November 2009. *Design and Construction of Mechanically Stabilized Earth Walls and Reinforced Slopes*, Publication No. FHWA-NHI-09-085.
- U.S. Department of Transportation, Federal Highway Administration, Washington D.C., June 1999. *Ground Anchors and Anchored Systems*, Publication No. FHWA-IF-99-015.

U.S. Department of Transportation, Office of Bridge Technology, Federal Highway Administration, Washington D.C., *Geotechnical Engineering Circular No. 6 – Shallow Foundations*, September 2002. Publication No. FHWA-SA-02-054.

U.S. Department of Transportation, Office of Bridge Technology, Federal Highway Administration, Washington D.C., 1995, *Geotechnical Engineering Circular No. 1 - Dynamic Compaction*, Publication No. FHWA SA-95-037.