

# Check Dam

## Definition

Small barrier, grade control structure, or dam constructed across a swale, drainage ditch, or other channelized flow of water. Also known as in-stream/channel energy dissipaters, ditch checks, prefabricated check dams, and permeable runoff structures.

## Description and Purpose

Check dams reduce scour and channel erosion by reducing flow velocity and encouraging sediment settlement by reducing the effective slope of the channel. A check dam is a device constructed of angular or crushed stone, crushed concrete, gravel bags, fiber rolls, or other prefabricated products placed across a natural or man-made channel or ditch.

Runoff water runs through and spills over the top of check dams and continues along the drainage way or swale. Check dams in a channel or ditch should be placed in series along gradients to act like terraces.

Check dams can be either temporary (during construction) or permanent.

### Pollutants controlled:

- Suspended solids

### Treatment Mechanisms:

- Slows runoff velocity and protects the channel substrate and establishing vegetation.
- Disperses or redirects concentrated flows within in the channel to reduce erosion potential.
- May collect sediment by acting as a small settling basin

### Pollution Removal Efficiencies:

- Primary purpose is to prevent channel erosion.
- May be effective in removing large, dense particulates. Removal efficiency is typically less than 80%.

## Companion and Alternative BMPs

- Utilized in [Diversions](#), Storm Water Conveyance Channels, and Grassed Waterways to reduce erosive velocity and aid vegetation establishment.

## **Advantages and Disadvantages**

### Advantages:

- Small footprint, fits within an existing channel
- Simple and inexpensive design, easy to install
- Ease of access for cleanout and maintenance
- Can be used for pretreatment to reduce velocity and provide some removal of solids
- May be modified to provide filtration
- Materials may recycled/reused: (stone, crushed concrete, and prefabricated products)

### Disadvantages:

- Can not be used in streams unless approved by DNRE permit.
- Additional downstream treatment necessary for sediment laden storm water
- Reduce the hydraulic capacity of the channel
- May clog with leaves in autumn
- Must be carefully designed and installed to assure minimization of erosion

## **Location**

- In temporary and permanent storm water conveyance channels draining less than ten acres.
- Upstream of surface waters or treatment practices

## **General Characteristics**

- Installed in a series with spacing dependent on channel slope
- Installed perpendicular to channel flow
- Low point of the dam (Spillway) in the center. High point along the channel side slope.
- May be temporary or permanent

## **Materials**

- Materials and design can vary according to need and conditions.
- Crushed or angular aggregate (stone or crushed concrete) underlain with geotextile.
- Other materials: Gravelbags, prefabricated synthetic products
- Do Not Use: straw bales, silt fence, logs, and similar materials which create a vertical downstream face, as they may create a plunge pool and undercutting, leading to failure

## **Design**

1. Install perpendicular to channel flow to ensure that water does not flow around them.
2. Installed in a series. Steeper gradients require dams to be closer together. The down-gradient toe of the dam is at the same elevation as the bottom of the spillway opening of the next dam downstream.
3. The middle of the dam should be 6-9 inches lower than the outer edges.
4. Spillway should be no taller than 2 feet above the channel bottom, or the potential for downstream scouring increases
5. Underlay with a non-woven geotextile fabric, which is toed in 6 inches at the upstream edge.
6. The upstream and downstream faces should be 2:1 or flatter. Flatter slopes reduce traffic hazards. Slope and height of check dams in transportation corridors must follow safety specifications of the transportation agency.
7. Scour protection (riprap, geotextile fabric, or mulch blankets) should be installed for at least 2 feet immediately below the check dam to dissipate energy and to prevent scouring and undercutting.
8. Aggregate size should increase with increased slope and velocity. Size may range from 4 to 15 inches. A small "bedding stone" placed under large aggregate may prevent scouring and undercutting
9. Aggregate should extend up the banks of the channel to a point a minimum of 18 inches above anticipated flows to avoid washouts and overflow around the dam.
10. Gravel bags must be securely sealed and placed by hand in an interlocking pattern.

## **Performance Enhancers**

- Excavate a sump/sediment pool above the dam to increase storage volume and enhance settling.
- Can be modified to work as a Filter by adding smaller aggregate on the upstream side.

## **Construction Guidelines**

1. Construct concurrently with channel construction, during any time of year
2. Place and toe-in geotextile underlay and downstream scour protection
3. Place aggregate material in the center of the channel to the desired center height
4. Place aggregate moving outward toward channel edge. The top of the check dam at the channel edge should be at least 6 inches higher than the center, creating a parabolic or trapezoidal downstream overflow profile.

## **After Construction**

- Remove temporary check dams only after vegetation or permanent channel lining has been established.
- Remove or grade accumulated sediment prior to permanent seeding and mulching.
- For permanent check dams, an operation and maintenance plan which includes regular inspections of structural integrity and removal of accumulated sediment, shall be developed. It is important that the placement of

permanent check dams be considered during channel design, as check dams will decrease the capacity of the channel.

### **Maintenance**

Check dams should be inspected weekly and after each runoff event from rain or snowmelt. Washouts, sidecutting, undercutting, scouring, and deteriorating gravel bags should be repaired immediately. If erosion occurs between dams, install a protective channel liner (riprap, mulch blanket, etc.), or additional checkdams

To ensure water can flow through the dam, sediment should be removed when it accumulates to 1/2 the height of the dam, placed in an approved upland area and stabilized.

### **References**

- California Stormwater Quality Association. 2003. *California Stormwater BMP Handbook*. Section SE-4: Check Dams.  
<https://www.casqa.org/resources/bmp-handbooks/construction>
- Massachusetts DEP. 2008. *Massachusetts Stormwater Handbook*. Volume 2, Chapter 2: Structural BMP Specifications.  
<http://www.mass.gov/eea/docs/dep/water/laws/i-thru-z/v2c2.pdf>
- National Pollutant Discharge Elimination System (NPDES) BMPs.
- Virginia Department of Conservation and Recreation. 1995. *Virginia Erosion & Sediment Control Field Manual*. 2nd ed. Virginia Department of Conservation and Recreation, Division of Soil and Water Conservation, Richmond, VA.
- Metropolitan Council/Barr Engineering co. 2000 Sediment Control Check Dams
- IDEQ Storm Water Best Management Practices Catalog, September 2005
- State of New York Department of Transportation, 2003. Soil Erosion & Sedimentation Control – Check Dams

# Exhibit 1: Typical Aggregate Check Dam Schematic

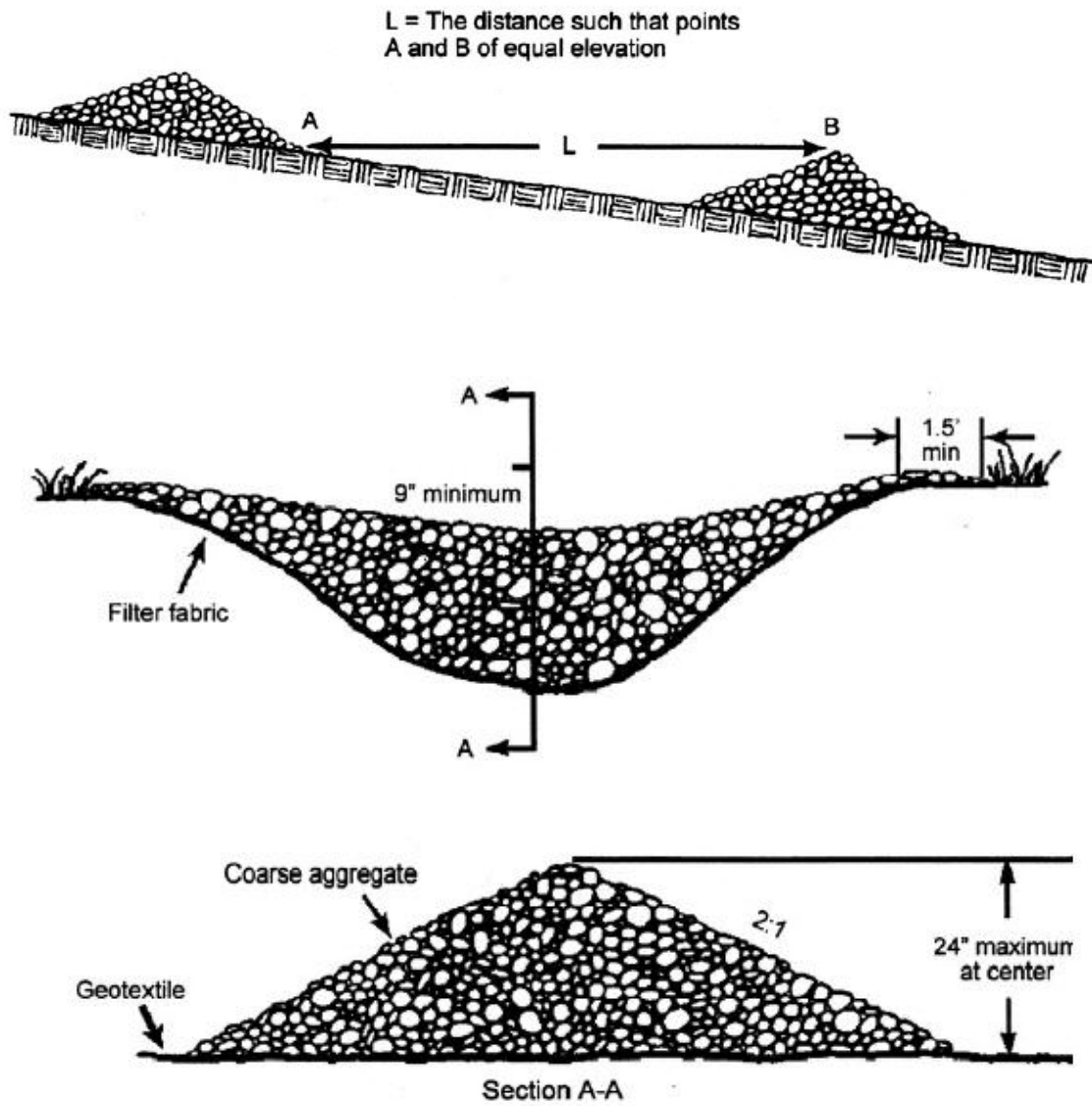

Source: Metropolitan Council/Barr Engineering co. 2000 Sediment Control Check Dams

**Exhibit 2: Typical Cross Sectional Schematic of a Gravel Bag Check Dam**

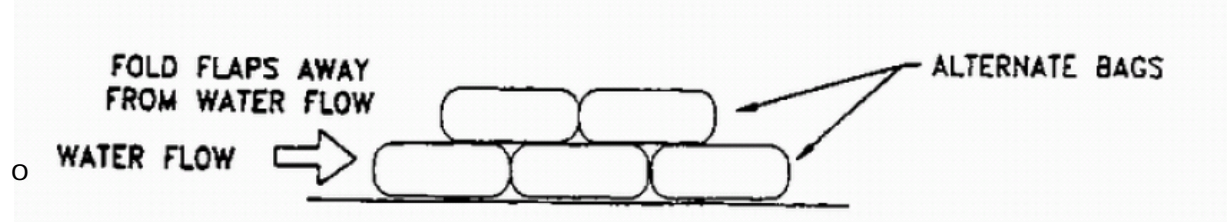

Source: IDEQ Storm Water Best Management Practices Catalog, September 2005

**Exhibit 3: Typical Prefabricated Permeable Runoff Control Structure Schematic**

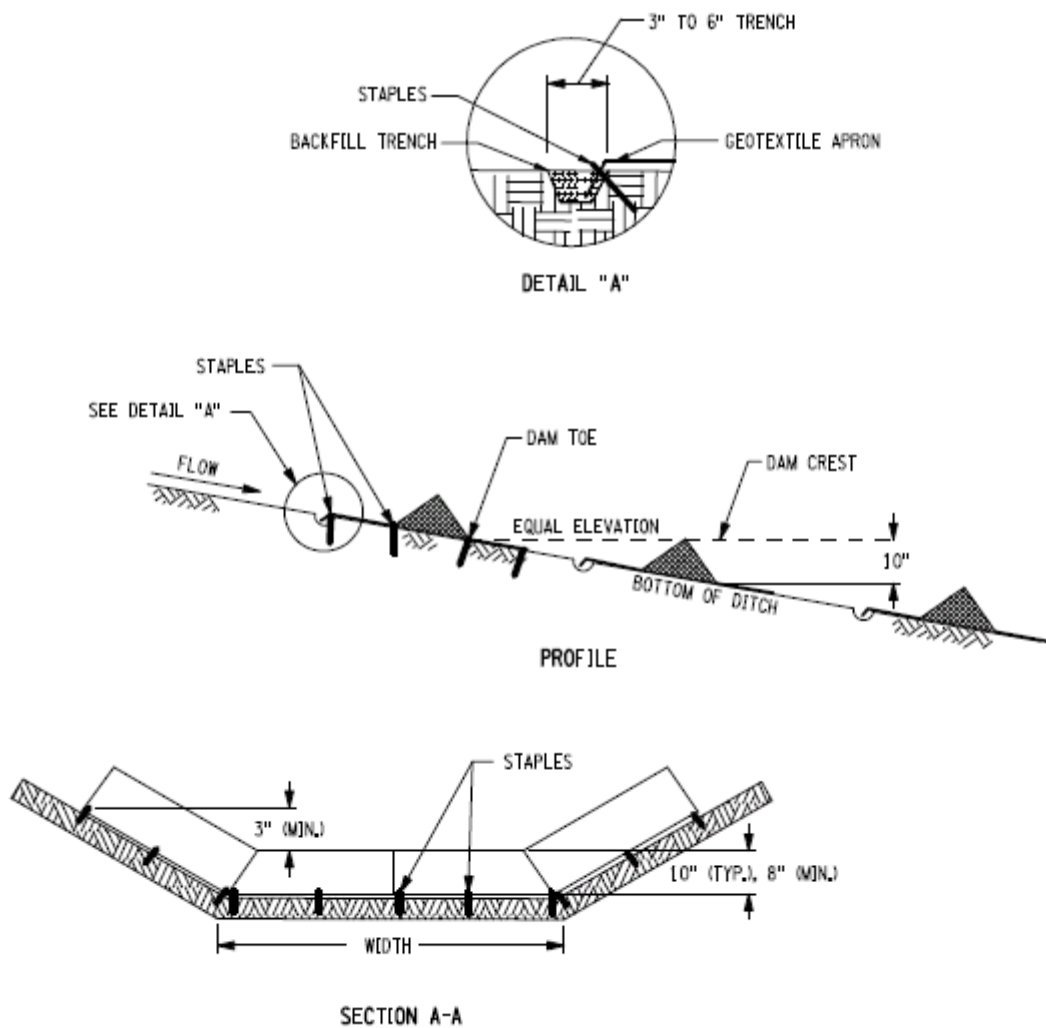

- Notes:
1. Install per manufacturer's specifications
  2. Use in conjunction with mulch blankets or other downstream scour protection

Source: State of New York Department of Transportation, 2003. Soil Erosion & Sedimentation Control – Check Dams