



**DEPARTMENT OF LICENSING AND REGULATORY AFFAIRS**  
**DIRECTOR'S OFFICE**  
**CONSTRUCTION SAFETY STANDARDS**

Filed with the Secretary of State on June 23, 1992 (as amended September 3, 1996) (as amended April 11, 2000)  
(as amended March 5, 2008) (as amended April 29, 2013) **(as amended September 17, 2013)**

These rules become effective immediately upon filing with the Secretary of State  
unless adopted under sections 33, 44, or 45a(6) of 1969 PA 306.

Rules adopted under these sections become effective 7 days after filing with the Secretary of State.

(By authority conferred on the director of the department of licensing and regulatory affairs  
By sections 19 and 21 of 1974 PA 154, and Executive Reorganization Order Nos. 1996-2, 2003-1,  
2008-4, and 2011-4, MCL 445.2001, 445.2011, 445.2025, and 445.2030)

R 408.43205, R 408.43206, R 408.43208, R 408.43212, R 408.43214, and R 408.43216  
of the Michigan Administrative Code are amended,  
and R 408.43203 of the Code is rescinded as follows:

**PART 32. AERIAL WORK PLATFORMS**

Table of Contents:

R 408.43201 Scope. ....	1	R 408.43208 Preoperational procedures. ....	4
R 408.43202 Equipment covered. ....	1	R 408.43209 Electrical hazards. ....	4
R 408.43204 Definitions.....	2	R 408.43212 Vehicles; traffic control.....	6
R 408.43204a Adopted and referenced standards.....	2	R 408.43214 Fall protection. ....	6
R 408.43205 Construction. ....	3	R 408.43216 Operating procedures. ....	6
R 408.43206 Insulated aerial device testing.....	3	R 408.43220 Figures.....	7
R 408.43207 Permits; training. ....	3		

**R 408.43201 Scope.**

**Rule 3201.** These rules apply to the construction, operation, maintenance, and inspection of aerial work platforms with either manual or powered mobility as used in construction operations as defined by 1974 PA 154, MCL 408.1001 to MCL 408.1094.

**R 408.43202 Equipment covered.**

**Rule 3202.** (1) These rules apply to equipment that has a primary function of elevating personnel, together with their tools and necessary materials, on a platform, which is mechanically positioned. The units covered are described by the following American national standards institute standards:

(a) ANSI standard A92.2, 2002 edition, "Vehicle-Mounted Elevating and Rotating Aerial Devices," which is adopted by reference in R 408.43204a. This standard applies to vehicle-mounted devices installed on commercial chassis and covers the following type of units (See figure 1):

- (i) Extensible boom aerial devices.
- (ii) Aerial ladders.
- (iii) Articulating boom aerial devices.
- (iv) Vertical towers.

(v) A combination of any of the equipment specified in paragraphs (i) to (iv) of this subdivision.

(b) ANSI standard A92.3, 2006 edition, "Manually Propelled Elevating Aerial Platforms," which is adopted by reference in R 408.43204a. This standard applies to work platforms which are manually propelled, which are vertically adjustable by manual or powered means, and which may be towed or manually moved horizontally on wheels or casters that are an integral part of the work platform base. (See figure 2).

(c) ANSI standard A92.5, 2006 edition, "Boom-Supported Elevating Work Platforms," which is adopted by reference in R 408.43204a. This standard applies to all integral frame, boom-supported elevating work platforms which telescope, articulate, rotate, or extend beyond the base dimensions. (See figure 3).

(d) ANSI standard A92.6, 1999 edition, "Self-Propelled Elevating Work Platforms," which is adopted by reference in R 408.43204a. This standard applies to self-propelled vertically adjustable integral chassis work platforms. Such work platforms are power-operated with primary controls for all movement operated from the platform. (See figure 4).

(2) Equipment adapted to elevating personnel with a primary function other than elevating personnel, such as fork trucks or cranes, are not covered by these rules. Those types of equipment are provided for in construction safety standards Part 10. "Lifting and Digging Equipment," R 408.41001a to R 408.41099a and Part 13. "Mobile Equipment," R 408.101301.

**Exception:** If the above-adapted equipment is equipped with controls that can be operated from the platform, then the requirements of R 408.43205 to R 408.43216 shall apply.

R 408.43203 Rescinded.

#### **R 408.43204 Definitions.**

**Rule 3204. (1)** "Aerial device" or "aerial work platform" means an entire device that is designed and manufactured to raise personnel to an elevated work position on a platform supported by scissors, masts, or booms.

(2) "Aerial ladder" means an aerial device that consists of a single- or multiple-section rung ladder.

(3) "Articulating boom" means an aerial device that has two or more hinged boom sections.

(4) "Authorized person" means a person who is approved and assigned to perform specific types of duties by the employer and who is qualified to perform those duties because of his or her training or experience.

(5) "Commercial chassis" means a vehicle that is built for over-the-road (roadway) travel.

(6) "Exposed power line" means a power line that is not isolated or guarded.

(7) "Extensible boom" means an aerial device, except for the aerial ladder-type, that has a telescopic boom.

(8) "Insulated aerial device" means an aerial work platform that is designed with dielectric components to meet specific electrical insulating ratings.

(9) "Mechanically positioned" means that the elevating assembly, whether a mechanical (cable or chain), hydraulic, pneumatic, electric or other powered mechanism, is used to raise or lower the platform.

(10) "Platform" means the portion of an aerial work platform, such as a bucket, basket, stand, cage, or the equivalent, that is designed to be occupied by personnel.

(11) "Power Line" means a distribution or transmission electrical line.

(12) "Qualified person" means a person who possesses a recognized degree, certificate, professional standing, or skill and who, by knowledge, training, and experience, has demonstrated the ability to deal with problems relating to the subject matter, the work, or the project.

(13) "Qualified telecommunications employee" means an employee trained to work on communication lines in the proximity of energized power transmission and distribution lines.

(14) "Vehicle" means any carrier that is not manually propelled.

(15) "Vehicle-mounted elevating and rotating work platform" means an aerial device or aerial work platform.

(16) "Vertical tower" means an aerial device that is designed to operate vertically on a level surface.

#### **R 408.43204a Adopted and referenced standards.**

**Rule 3204a. (1)** The standards specified in this rule, except for the standards specified in subrule (2) of this rule, are adopted by reference.

(a) The following American National Standard Institute (ANSI) standards are available from Global Engineering Documents, 15 Inverness Way East, Englewood, Colorado, 80112, USA, telephone number: 1-800-854-7179 or via the internet at web-site: <http://global.ihc.com>; at a cost, as of the time of adoption of these rules, as stated in this subrule:

(i) ANSI A92.3, "Manually Propelled Elevating Aerial Platforms," 2006 edition. Cost: \$68.00.

(ii) ANSI A92.5, "Boom-Supported Elevating Work Platforms," 2006 edition. Cost: \$68.00.

(b) The following ANSI standards are available from the Scaffold and Access Industry Association, 400 W. Admiral Blvd., Kansas City, Missouri, 64106, USA, telephone number: 1-816-595-4860 or via the internet at website: [www.shop.saiaonline.org](http://www.shop.saiaonline.org); at a cost, as of the time of adoption of these rules, as stated in this subrule:

(i) ANSI A92.2, "Vehicle-Mounted Elevating and Rotating Aerial Devices," 2001 edition. Cost: \$45.00

(ii) ANSI A92.6, "Self-Propelled Elevating Work Platforms," 1999 edition. Cost: \$45.00

(c) The "Manual on Uniform Traffic Control Devices, Part 6: Temporary Traffic Control," 2011 Michigan/2009 Federal Edition is available at no cost from the Michigan Department of Transportation via the Internet at website: [www.michigan.gov/mdot](http://www.michigan.gov/mdot). The entire 2011 Michigan Manual on Uniform Traffic Control Devices (MMUTCD) may be purchased from the Michigan Department of Transportation, Cashiers Office, P.O. Box 30648, Lansing, Michigan 48909-8148; (517) 322-1676; at a cost of \$145.00 as of the time of adoption of these rules.

(d) The standards adopted in subrule 1(a) to (c) of this rule are also available for inspection at the Department of Licensing and Regulatory Affairs, MIOSHA Standards Section, 7150 Harris Drive, P.O. Box 30643, Lansing, Michigan, 48909-8143.

(e) Copies of the standards adopted in subrule 1(a) to (c) of this rule may be obtained from the publisher or may also be obtained from the Department of Licensing and Regulatory Affairs, MIOSHA Standards Section, 7150 Harris Drive, P.O. Box 30643, Lansing, Michigan, 48909-8143, at the cost charged in subrule 1(a) to (c), of this rule, plus \$20 for shipping and handling.

(2) The following Michigan Occupational Safety and Health Standards are referenced in these rules. Up to 5 copies of these standards may be obtained at no charge from the Michigan Department of Licensing and Regulatory Affairs, MIOSHA Standards Section, 7150 Harris Drive, P.O. Box 30643, Lansing, Michigan, 48909-8143 or via the internet at web-site: [www.michigan.gov/mioshastandards](http://www.michigan.gov/mioshastandards). For quantities greater than 5, the cost, as of the time of adoption of these rules, is 4 cents per page.

(a) Construction Safety Standard Part 6. Personal Protective Equipment, R 408.40601 to R 408.40641.

(b) Construction Safety Standard Part 10. Lifting and Digging Equipment, R 408.41001a to R 408.41099a.

(c) Construction Safety Standard Part 13. Mobile Equipment, R 408.101301.

(d) Construction Safety Standard Part 22. Signals, Signs, Tags, and Barricades, R 408.42201 to R 408.42243.

(e) Construction Safety Standard Part 45. Fall Protection, R 408.44501 to R 408.44502.

(f) General Industry Safety Standard Part 7. Guards for Power Transmission, R 408.10701 to R 408.10765.

#### **R 408.43205 Construction.**

**Rule 3205.** (1) Aerial work platforms shall be designed, constructed, and tested so as to be in compliance with the requirements of the following applicable American national standards institute standards:

(a) ANSI standard A92.2, 2002 edition, "Vehicle-Mounted Elevating and Rotating Aerial Devices."

(b) ANSI standard A92.3, 2006 edition, "Manually Propelled Elevating Aerial Platforms."

(c) ANSI standard A92.5, 2006 edition, "Boom-Supported Elevating Work Platforms."

(d) ANSI standard A92.6, 1999 edition, "Self-Propelled Elevating Work Platforms."

These standards are adopted by reference in R 408.43204a.

(2) Aerial work platforms shall not be field-modified for uses other than those intended by the manufacturer, unless the modification has been certified in writing by the manufacturer or by any other equivalent entity, such as a nationally recognized testing laboratory, to be in compliance with the applicable ANSI standard and this rule, and to be at least as safe as the equipment was before modification.

(3) Aerial work platforms shall be equipped with emergency controls at ground level.

(4) Emergency ground level controls shall be clearly marked as to their intended function and be capable of overriding the platform controls.

(5) Attachment points shall be provided for fall protection devices for personnel who occupy the platform on aerial work platforms described in R 408.43202 (a) and (c). (See figures 1 and 3).

#### **R 408.43206 Insulated aerial device testing**

**Rule 3206.** If the aerial work platform is rated and used as an insulated aerial device, an employer shall test the electrical insulating components for compliance with the rating of the aerial work platform in accordance with ANSI standard A92.2, 2002 edition, which is adopted in R 408.43204a. Such testing shall comply with all of the following provisions:

(a) The test shall be performed not less than annually.

(b) Written, dated, and signed test reports shall be made available by the employer for examination by a department representative.

(c) The insulated portion of an aerial device shall not be altered in any manner that might reduce its insulating value.

#### **R 408.43207 Permits; training.**

**Rule 3207.** (1) An employer shall provide the operator of an aerial work platform with an aerial work platform permit.

(2) The requirements of subrule (8)(a), (b), (c), and (d) of this rule shall be met before an employee is issued a permit.

(3) A permit shall be carried by the operator or be available at the job site and shall be displayed upon request by a department of licensing and regulatory affairs representative.

(4) A permit shall indicate the type of aerial work platforms an operator has been trained on and is qualified to operate.

(5) A permit to operate an aerial work platform is valid only when performing work for the employer who issued the permit. A permit shall be issued for a period of not more than 3 years.

(6) A permit shall contain all of the following information (see sample permit):

(a) Firm name.

(b) Operator's name.

(c) Name of issuing authority. (Authorized by)

(d) The following types of aerial work platform the operator is authorized to operate:

(i) Vehicle-mounted elevating work platform such as the following:

(A) Extensible boom aerial devices.

(B) Aerial ladders.

(C) Articulating boom aerial devices.

(D) Vertical towers.

(ii) Manually propelled elevating work platforms.

(iii) Boom-supported elevating work platforms.

(iv) Self-propelled elevating work platforms.

(e) Date issued.

(f) Expiration date.

(7) The following is a sample permit:

**SAMPLE PERMIT**

<b>AERIAL WORK PLATFORM PERMIT</b>			
_____			
<i>(Firm Name)</i>			
_____			
<i>(Name)</i>			
Type of aerial work platform authorized to operate:			
Date Issued	Type	Authorized by	Expiration Date

(8) An employer shall provide each employee who will operate the aerial work platform with instruction and training regarding the equipment before a permit is issued or reissued. Such instruction and training shall ensure that each operator is in compliance with the minimum following provisions:

(a) Is instructed by a qualified person in the intended purpose and function of each of the controls.

(b) Is trained by a qualified person or reads and understands the manufacturer's or owner's operating instructions and safety rules.

(c) Understands by reading or by having a qualified person explain, all decals, warnings, and instructions displayed on the aerial work platform.

(d) Reads and understands the provisions of this subrule and subrules (1) to (7) and (9) of this rule or be trained by a qualified person on their content.

(9) The manufacturer's operating instructions and safety rules shall be provided and maintained in a legible manner on each unit by the employer.

**R 408.43208 Preoperational procedures.**

**Rule 3208.** (1) The employer shall ensure before the commencement of operations near power lines and when the clearances cannot be maintained as specified in Tables 1-3, that the owner, owner representative, or utility are notified with all pertinent information about the job.

(2) Any overhead wire shall be considered to be an energized line until the owner of the line, his or her authorized representative, or a utility representative assures either of the following:

(a) The line is de-energized and has been visibly grounded.

(b) The line is insulated for the system voltages and the task will not compromise the insulation of the conductor and/or cause an electrical hazard.

**R 408.43209 Electrical hazards.**

**Rule 3209.** (1) The employer shall ensure that an aerial work platform shall be operated so that the distances from energized power lines and equipment prescribed in Table 1 are maintained, except for the following:

(a) As prescribed in subrule (2) of this rule addressing tree trimming.

(b) As prescribed in subrule (3) of this rule addressing telecommunications.

(c) Where insulating barriers are not a part of or an attachment to the aerial device that has been erected to prevent physical contact with the lines.

(2) A qualified lineman or a qualified line clearance tree trimmer shall maintain distances as prescribed in Table 2 when performing work from an aerial work platform on or near an exposed power line unless any of the following conditions exist:

(a) The employee is insulated or guarded from the energized part by gloves or gloves and sleeves, as provided for and prescribed in Construction Safety Standard Part 6. "Personal Protective Equipment" and Construction Safety Standard Part 30. "Telecommunications."

(b) The employee is insulated, isolated, or guarded from any other conductive part.

(c) The energized part is insulated from the employee.

(3) A qualified telecommunications employee shall maintain the distances prescribed in Table 3 when working from an aerial lift, unless the employee is insulated, isolated, or guarded from any other conductive part or the energized part is insulated from the employee.

(4) Employees shall use insulated bucket, gloves and sleeves that are rated at more than the voltage to be worked on or that with which they might come into contact, to comply with subrules (2) and (3) of this rule.

(5) The clearances, as prescribed in Tables 1-3, do not apply when the owner of the line or his or her authorized representative, or a utility representative assures that the conductor is insulated for the system voltages and the task will not compromise the insulation of the conductor and/or cause an electrical hazard.

(6) Tables 1, 2, and 3 read as follows:

<b>Table 1 Minimum Clearance Distances for Equipment</b>		
<b>Voltage</b>	<b>Clearance With Boom Raised</b>	<b>Clearance Boom Lowered and No Load in Transit</b>
To 50 kV	10 feet	4 feet
Over 50 kV	10 feet + .4 inch per each 1 kV over 50 kV	10 feet
50 to 345 kV	--	10 feet
346 to 750 kV	--	15 feet

<b>Table 2 Minimum Working Distances for Qualified Line-Clearance Tree Trimmers and Qualified Linemen</b>	
<b>Voltage Range Phase to Phase (kilovolts)</b>	<b>Minimum Working Distance</b>
2.1 to 15.0	2 feet 0 inches (61 cm)
15.1 to 35.0	2 feet 4 inches (71 cm)
35.1 to 46.0	2 feet 6 inches (76 cm)
46.1 to 72.5	3 feet 0 inches (91 cm)
72.6 to 121.0	3 feet 4 inches (102 cm)
138.0 to 145.0	3 feet 6 inches (107 cm)
161.0 to 169.0	3 feet 8 inches (112 cm)
230.0 to 242.0	5 feet 0 inches (152 cm)
345.0 to 362.0	*7 feet 0 inches (213 cm)
550.0 to 552.0	*11 feet 0 inches (335 cm)
700.0 to 765.0	*15 feet 0 inches (457 cm)

\*Note: For 345-362 kV., 500-552 kV., and 700-765 kV., the minimum working distance and the minimum clear hot stick distance may be reduced that such distances are not less than the shortest distance between the energized part and a grounded surface.

<b>Table 3 Minimum Approach Distances for Qualified Telecommunications Employees</b>	
<b>Voltage Range (Nominal Phase to Phase)</b>	<b>Minimum Approach Distances</b>
300 V and less	1 foot - 0 inches (30.5 cm)
Over 300 V, not over 750 V	1 foot - 6 inches (46 cm)
Over 750 V, not over 2 kV	2 feet - 0 inches (61 cm)
Over 2 kV, not over 15 kV	3 feet - 0 inches (91 cm)
Over 15 kV, not over 37 kV	3 feet - 6 inches (107 cm)
Over 37 kV, not over 87.5 kV	4 feet - 0 inches (122 cm)
Over 87.5 kV, not over 121 kV	4 feet - 6 inches (137 cm)
Over 121 kV, not over 140 kV	--

**R 408.43212 Vehicles; traffic control.**

**Rule 3212.** (1) Before moving a vehicle supporting an aerial ladder for highway travel, employees shall secure ladders in the lower position and shall use the manually operated device at the base of the ladder, or other effective means to prevent elevation or rotation of the ladder.

(2) Before moving a vehicle supporting an aerial lift for travel, employees shall inspect the boom to ensure that it is properly cradled and the outriggers are in the stowed position, except as provided in subrule (3) of this rule.

(3) When a boom is elevated with employees in working position, the vehicle supporting an aerial device shall not be moved unless the equipment is specifically designed for this type of operation and meets the requirements of R 408.43205.

(4) An employer shall ensure that operators of an aerial work platform over or adjacent to any public or private roadway maintain adequate clearances of all portions of the aerial work platform to prevent being struck by vehicular traffic.

(5) When aerial work platforms are in use, all traffic control requirements shall be in compliance with Part 6 of the 2011 Michigan Manual on Uniform Traffic Control Devices (MMUTCD), which is adopted in R 408.43204a, and Construction Safety Part 22. Signals, Signs, Tags, and Barricades, as referenced in R 408.43204a.

**R 408.43214 Fall protection.**

**Rule 3214.** (1) The employer shall provide a safety harness that has a lanyard which is in compliance with construction safety standard Part 45. "Fall Protection," R 408.44501 to R 408.44502 and which is affixed to attachment points provided and approved by the manufacturer. Any occupant of an aerial work platform described in the provisions of R 408.43202(a) and (c) and figures 1 and 3 shall use the harness. A fall arrest system shall only be used where the aerial lift is designed to withstand the vertical and lateral loads caused by an arrested fall.

(2) An employee may use a body belt with a restraint device with the lanyard and the anchor arranged so that the employee is not exposed to any fall distance. An employee shall use a restraint device where the aerial lift cannot withstand the vertical and lateral loads imposed by an arrested fall.

(3) An employee shall be prohibited from belting off to an adjacent pole, structure, or equipment while working from an aerial work platform.

(4) An employer shall not allow employees to exit an elevated aerial work platform, except where elevated work areas are inaccessible or hazardous to reach. Employees may exit the platform with the knowledge and consent of the employer. When employees exit to unguarded work areas, fall protection shall be provided and used as required in construction safety standard Part 45. "Fall Protection," R 408.44501 to R 408.44502.

**R 408.43216 Operating procedures.**

**Rule 3216** (1) The aerial work platform shall be used only in accordance with the manufacturers or owners operating instructions and safety rules.

(2) The designed rated capacity for a given angle of elevation shall not be exceeded.

(3) The guardrail system of the platform shall not be used to support any of the following:

- (a) Materials.
- (b) Other work platforms.
- (c) Employees.
- (4) Employees shall maintain firm footing on the platform while working on the platform. The use of railings, planks, ladders, or any other devices on the platform for achieving additional height is prohibited.

(5) Only aerial work platforms that are equipped with a manufacturer's installed platform controls for horizontal movement shall be moved while in the elevated position.

(6) Before and during driving while elevated, an operator of a platform shall do both of the following:

(a) Look in the direction of, and keep a clear view of, the path of travel and make sure that the path is firm and level.

(b) Maintain a safe distance from all of the following:

- (i) Obstacles.
- (ii) Debris.
- (iii) Drop-offs.
- (iv) Holes.
- (v) Depressions.
- (vi) Ramps.
- (vii) Overhead obstructions.
- (viii) Overhead electrical lines.
- (ix) Other hazards to safe elevated travel.

(7) Outriggers or stabilizers, when provided, are to be used in accordance with the manufacturer's instruction. Brakes shall be set and outriggers and stabilizers shall be positioned on pads or a solid surface.

(8) Aerial work platforms shall be elevated only when on a firm and level surface or within the slope limits allowed by the manufacturer's instructions.

(9) A vehicle-mounted aerial work platform (figure 1) shall have its brakes set before elevating the platform.

(10) A vehicle-mounted aerial work platform (figure 1) shall have wheel chocks installed before using the unit on an incline.

(11) Climbers shall not be worn while performing work from an aerial work platform.

(12) Platform gates shall be closed while the platform is in an elevated position.

(13) Altering, modifying, or disabling safety devices or interlocks is prohibited.

R 408.43220 Figures.  
Rule 3220. Figures 1 to 4 are as follows:

Figure 1  
Vehicle-Mounted Elevating Work Platform

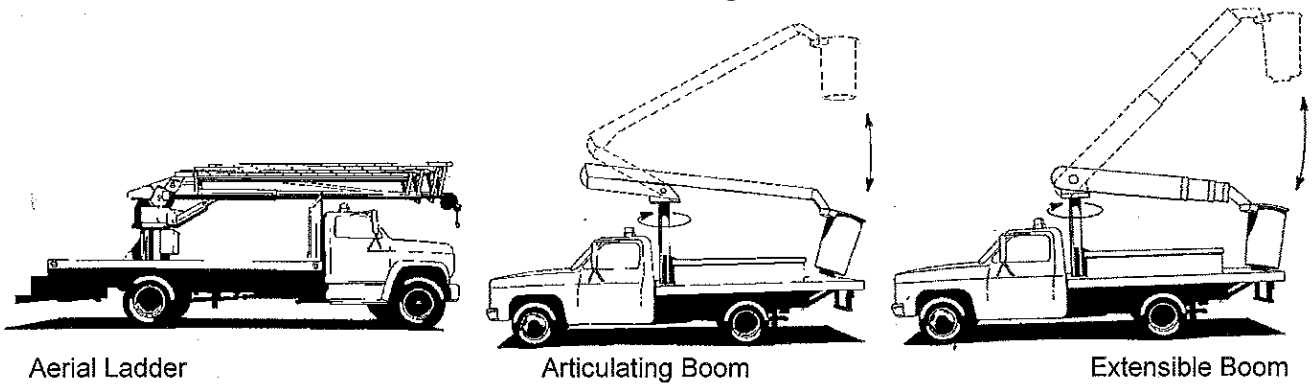

Figure 2  
Manually Propelled Elevating Work Platform

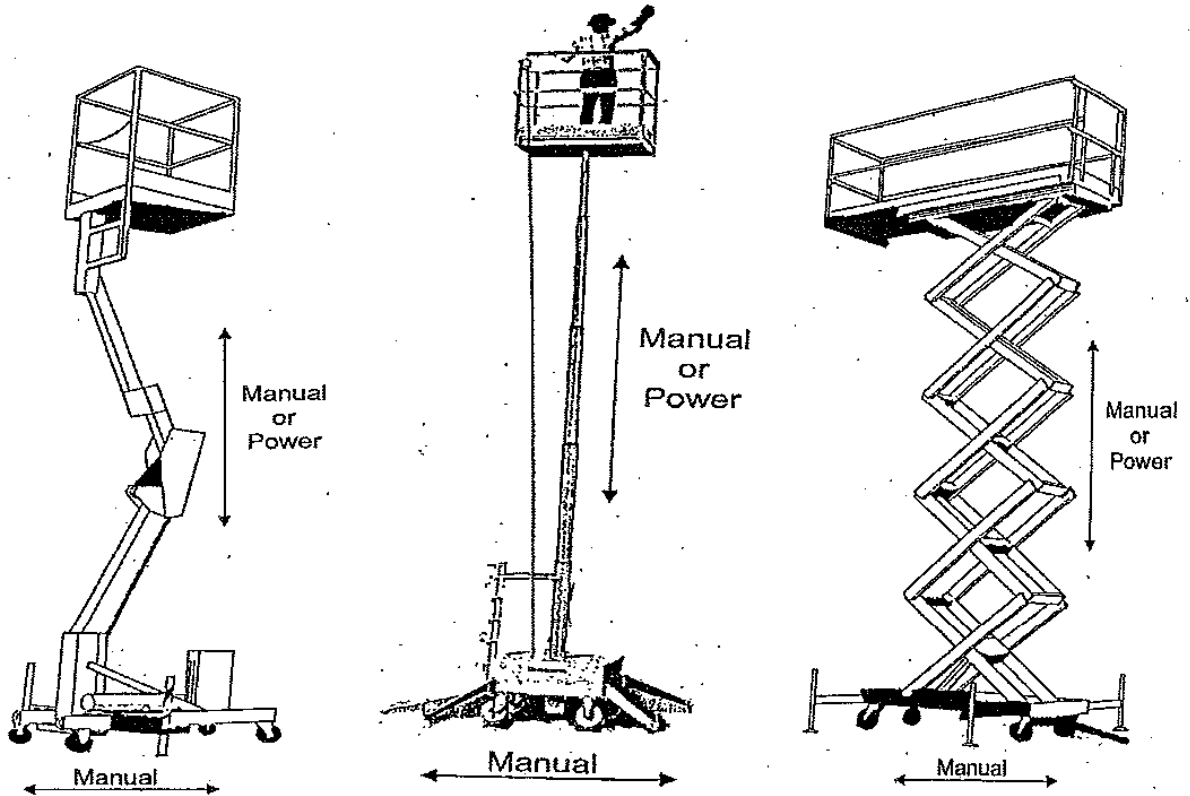

Figure 3  
Boom-Supported Elevating Work Platform

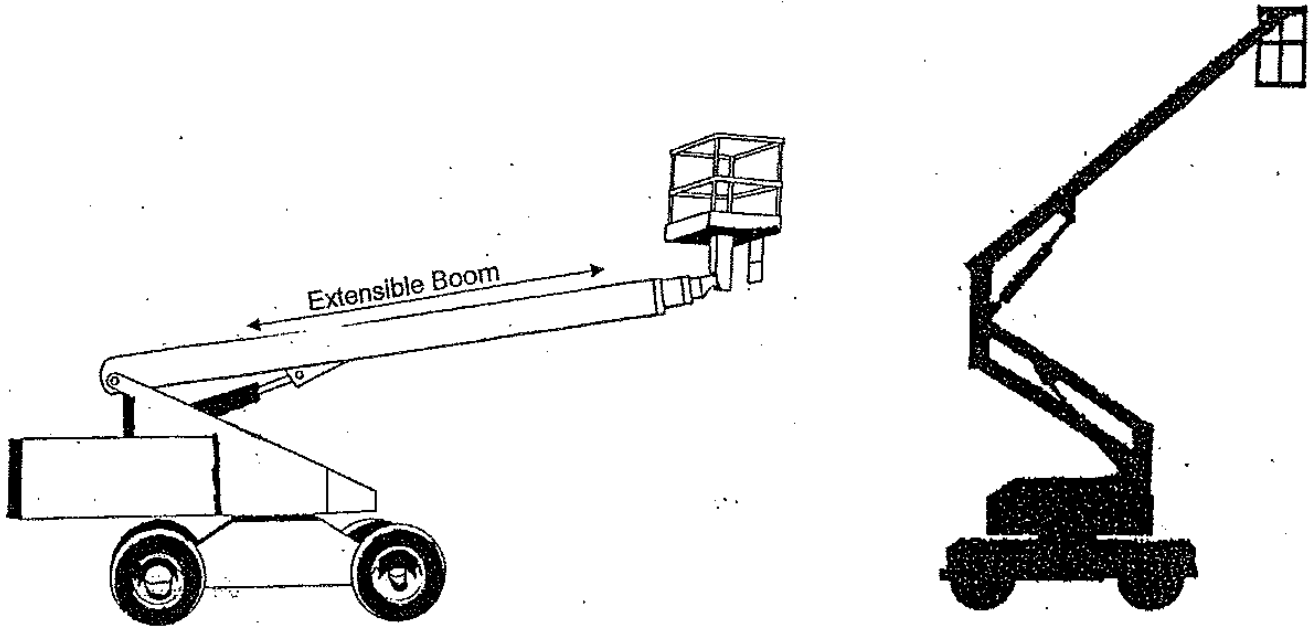
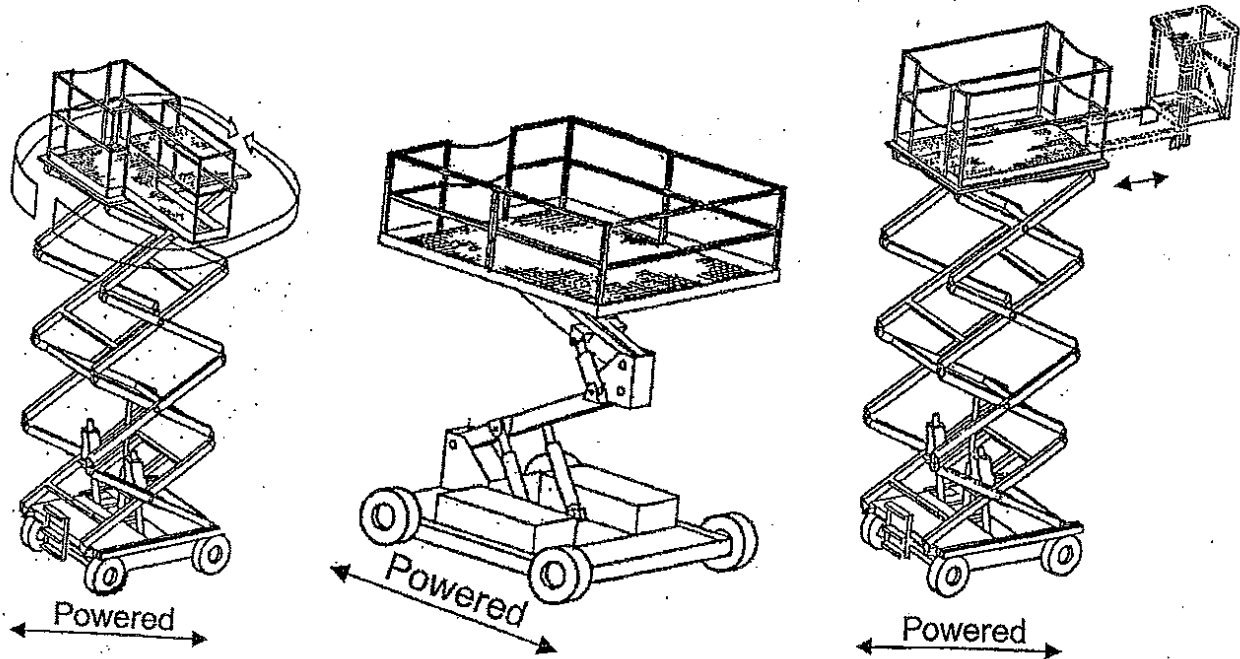

Figure 4  
Self-Propelled Elevating Work Platform









Michigan Occupational Safety and Health Administration  
PO Box 30643  
Lansing, Michigan 48909-8143  
Ph: 517-284-7740

The Department of Licensing and Regulatory Affairs will not discriminate against any individual or group because of race, sex, religion, age, national origin, color, marital status, disability, or political beliefs. Auxiliary aids, services and other reasonable accommodations are available upon request to individuals with disabilities.