

Tower Lighting Unit Installation Inspection Procedure

Description

This procedure describes the requirements for the installation inspection of tower lighting units.

General Structure Inspection

1) Obtain project plans.

- Upon receiving a work assignment from MDOT, the inspector must contact the project office to coordinate an inspection schedule and obtain the project plans for structure location information. Inspector must review the project plans to ensure all structures requiring inspection are completed. Record all observations on [MDOT form 1458](#).

2) Establish and record structure location.

- Record MDOT Region, County, Route, GPS coordinates (minimum 10 decimal places) and brief location description.

3) Inspect and record structure information.

- Upright Condition / Slip Connections
 - Tower lighting units are erected using sections connected by a slip connection. Record the number of sections that make up the tower lighting unit. Using binoculars, visually inspect the condition of the longitudinal seam welds, hand hole welds, and general structure condition. Record any signs of rust.
- Upright Lean
 - Measure and record the distance the upright leans in relation to the roadway. This must be measured using a 4-foot level and recorded as inches per 4 feet and direction related to the roadway (i.e. upright leans $\frac{1}{4}$ " in 4 feet away from traffic, towards traffic, with traffic or against traffic). Also note if each upper section is leaning and note the direction of lean in the remarks section of the inspection report.

4) Inspect and record anchor bolt information.

- Visually inspect the structure base looking for missing or damaged anchor bolts or nuts. Note any damage or corrosion and any bolts that have been bent to align with holes in the base plate. Inspect welds in the base looking for cracks or unusual welds. Inspect the base, gussets, and vertical support for corrosion, cracks, gouges, dents, etc. Inspect the condition of the concrete foundation, noting any spalling, cracks, voids, and general deterioration.

- Anchor Bolt Plan
 - Mark the bolt numbers on the vertical support with a yellow permanent paint marker corresponding to the example on the inspection reference detail sheet at the end of this procedure for future reference. Attach a plastic tag to the number one anchor bolt between the base plate and the concrete foundation including the date of inspection, structure number, and inspector's name and organization.
- Anchor Bolt Diameter
 - Measure and record the anchor bolt diameter.
- Anchor Bolt ID#
 - Record the anchor bolt ID# which is stamped into the exposed end of the anchor bolt.
- Turn-of-Nut Verification
 - Verify anchor bolts reflect the proper $1/6$ and $1/3$ turn-of-nut markings. Record any incorrect markings in the remarks section of the inspection report.
- Sounding Anchor Nuts
 - Hit the side of the top nuts and hit the top of the bolts using a 24 oz. hammer. This is done to check for loose nuts (leveling and top) and/or cracked or broken bolts. If the nuts are tight, there is a sharp ringing sound; if the nuts are loose, there is a dull sound. Visually check for any gaps between the nuts, washers and the base plate. Tap one side of each washer placing one hand on the washer opposite the side being tapped. If the washer moves, the nut is not properly tightened.
- Anchor Bolt Projection (P)
 - Measure and record the distance between the top of the top nut and the top of the anchor bolt. Note any bolts that are lower than the top of the nut and measure the depth. Record the measurement as a negative projection.
- Anchor Bolt Stand-Off Distance (S)
 - Measure and record the distance between the top of the concrete foundation and the bottom of the levelling nut. Note any stand-off distances greater than 1 inch in the remarks section of the inspection report.
- Anchor Bolt Ultrasonic Results
 - Ultrasonic Testing must be performed on all anchor bolts which are tightened using the turn-of-nut method. The individual doing the ultrasonic testing (UT) must be qualified as ASNT Level II, on recommended practice SNT-TC-1A.

Calibrate the ultrasonic unit for straight beam probe method using a 10-inch screen. The probe is placed on a 1-inch calibration block (DSC block or section of anchor bolt) and the indications on the screen are adjusted so that a reflection is positioned at each inch mark. Next, place the probe on a 9-inch-long test bar that has a $1/8$ -inch-deep saw cut at a set distance (3 inches from the end) in the threaded portion of the rod. Peak the back reflection from the $1/8$ -inch-deep saw cut until the indication is at 60 or 80 percent of screen height. The dB reading is recorded to establish the "REFERENCE LEVEL." The "SCANNING LEVEL" is set by

adding 14 to 30 dB over the reference level. Calibration should be checked at each location before inspecting any bolts.

Grind all anchor bolt ends flat being sure to remove all galvanizing, paint, dirt, and debris. Ensure the surface is as smooth and flat as possible since surface imperfections $\frac{1}{16}$ inch or greater can affect the UT results. Only grind the bolt a sufficient amount to remove any paint and smooth the surface.

Apply couplant (glycerin) to the ends of the bolts. Ultrasonically test the anchor bolts using a circular motion inspection pattern and record the results. When scanning the anchor bolts, there should be no indications on the CRT screen between the initial pulse and the end of the screen (10-inch depth). Any indication that is displayed after the initial pulse is a possible flaw. Record the depth of the discontinuity observed and the amount of dB required to bring the indication to the "REFERENCE LEVEL" on the screen. This is recorded as the "INDICATION LEVEL."

After the ultrasonic testing is complete, wipe off all the couplant with a wet rag, allow surface to dry completely, and spray the bolt ends with cold galvanizing or zinc-rich paint.

- Rodent Screen
 - Verify that a rodent screen has been properly installed around the foundation and baseplate. Note any deficiencies in the remarks section of the report.

Report Writing, Safety and Equipment

Reporting Procedure

All reports must be detailed and accurate and will be used as evidence of work performed. All reports must have a minimum of one photo of the overall structure attached. Provide additional photos of deficiencies prior to submitting the report to MDOT. All reports must be submitted to MDOT-StructuralFabrication@michigan.gov and files must be named as detailed below:

- 1458 SN-CS-JN Date
- Example: 1458 B332-82194-109971 101217

Safety

All inspections and related work must be in accordance with the Department's Personal Protective Equipment (PPE) Policy as stated in the MDOT Guidance Document [10118](#) and MIOSHA safety standards (use of safety apparel and equipment safety guards). Safety apparel and equipment (hard hats, leather gloves, harnesses, lanyards, safety glasses, safety shoes, and safety vests) must be worn by all workers.

Any unusual or potentially dangerous conditions must be reported immediately to the Structural Fabrication Unit at MDOT-StructuralFabrication@michigan.gov.

Equipment/Tool List

- Complete Ultrasonic Unit with Straight Beam Probe
- Distance and Sensitivity Calibration Block
- 8-10" calibration anchor bolt with a 1/8" cut 2-4" up from the bottom
- Couplant
- Rags
- Cold Galvanizing Spray or Zinc-Rich Paint
- Grinder
- 4 Foot Level
- 24 oz. Hammer
- Binoculars
- Identification Tags
- Yellow Paint Markers
- Tape Measure
- Voltage Detector
- [MDOT Form 1458, Tower Lighting Unit Installation Inspection Report](#)

Inspection Reference Detail

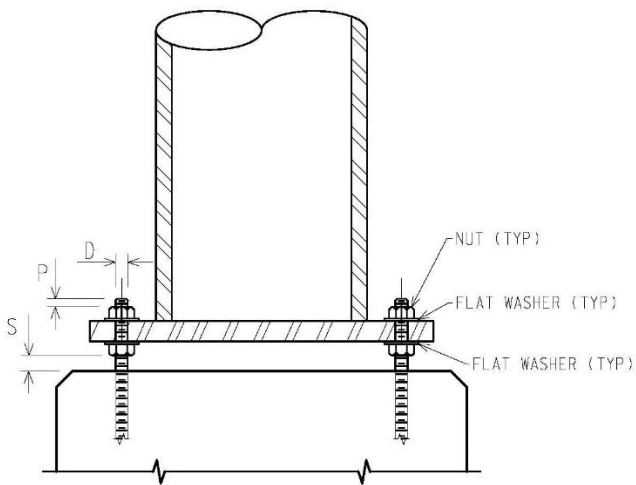
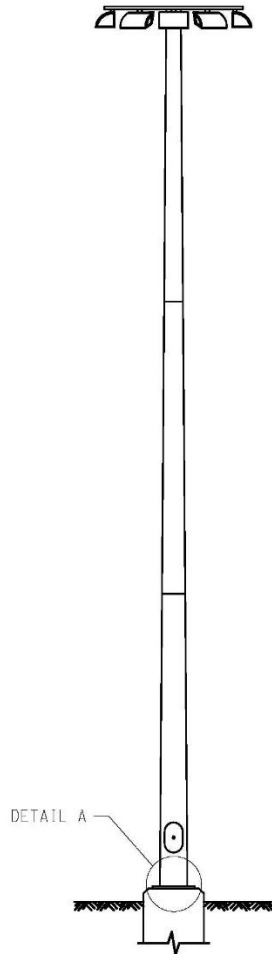

DETAIL A

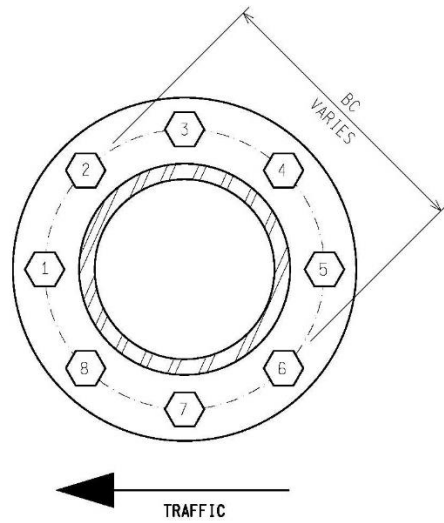

BOLT LAYOUT

NUMBER OF ANCHOR BOLTS AND BOLT
CIRCLE DIAMETER MAY VARY