

CATEGORY 2 GENERATOR INTERCONNECTION APPLICATION
 FOR ALL PROJECTS WITH AGGREGATE GENERATOR OUTPUT OF
 MORE THAN 20 KW BUT LESS THAN OR EQUAL TO 150 KW
 Also Serves as Application for Category 2 Net Metering
 (Note: Category 2 Net Metering Program only available to Renewable Generator Projects)

Electric Utility Contact Information

Utility Name
 Interconnection Coordinator
 Utility Street Address
 Utility Street Address
 Interconnection Hotline: XXX.XXX.XXXX
 Interconnection Email: xxxx@xxx.com

For Office Use Only	
Application No. _____	
Date & Time Application Received	

Customer / Account Information

Electric Utility Customer Information: (As shown on utility bill)

Customer Name (Last, First, Middle):
 Customer Mailing Address:

Customer E-Mail Address: (optional)
 Electric Service Account #
 Electric Service Meter Number:

Are you applying for the Net Metering Program?

Yes No

Are you interested in selling Renewable Energy Credits (REC's)

Yes No

Will you have an Alternative Electric Supplier?

Yes No

Notes: Enter name ONLY if your energy is supplied by a 3rd party, not the utility.
 You must apply to both the Distribution Utility and your Alternate Energy Provider (if applicable) for Net Metering

Alternative Electric Supplier Name

--

Generation System Site Information

Physical Site Service Address (if not Billing Address):

Annual Site Requirements Without Generation in Kilowatthours

	kW h/year
--	-----------

Peak Annual Site Demand in Kilowatts (only for customers billed on demand rates)

	kW /year
--	----------

Attached Site Plan:

Attached Electrical One-Line Drawing (See the Appendix D for a sample Inverter Type Project)

(Per MPSC Order in Case No. U-15787- The one-line diagram must be signed and sealed by a licensed professional engineer, licensed in the State of Michigan or by an electrical contractor licensed by the State of Michigan with the electrical contractor's license number noted on the diagram.)

Page #

Page #

Synchronous/Induction Generators: Must fill out Appendix A or B and provide a Detail One-Line Diagram

See Appendix E and F for a sample the Detail One-Line Diagram for Synchronous or Induction projects

Note: The following information on these system components shall appear on the preliminary Detail One-Line Diagram

Page #

- Breakers - Rating, location and normal operating status (open or closed)
- Buses - Operating voltage
- Capacitors - Size of bank in Kvar
- Circuit Switchers - Rating, location and normal operating status (open or closed)
- Current Transformers - Overall ratio, connected ratio
- Fuses - normal operating status, rating (Amps), type
- Generators - Capacity rating (kVA), location, type, method of grounding
- Grounding Resistors - Size (ohms), current (Amps)
- Isolating transformers - Capacity rating (kVA), location, impedance, voltage ratings, primary and secondary connections and method of grounding
- Potential Transformers - Ratio, connection
- Reactors - Ohms/phase
- Relays - Types, quantity, IEEE device number, operator lines indicating the device initiated by the relays.
- Switches - Location and normal operating status (open or closed), type, rating
- Tagging Point - Location, identification

CATEGORY 2 GENERATOR INTERCONNECTION APPLICATION

FOR ALL PROJECTS WITH AGGREGATE GENERATOR OUTPUT OF
MORE THAN 20 KW BUT LESS THAN OR EQUAL TO 150 KW

Also Serves as Application for Category 2 Net Metering

(Note: Category 2 Net Metering Program only available to Renewable Generator Projects)

Generation System - Manufacturer Information

System Type (Solar, Wind, Biomass, Methane Digester, etc):

Generator Type (Inverter, Induction, Synchronous):

Total Generator(s) Nameplate DC Rating (Solar Only):

kW

Total Generator(s) Nameplate AC Rating:

kW

Expected Annual Output in Kilowatthours

kWh/year

AC Output Operating Voltage:

Generator Wiring Configuration (Single Phase, Three Phase):

Is the Inverter tested to IEEE1547.1?

Yes No Not Applicable

Inverter Based Systems:

Manufacturer

Model (Name / Number)

Inverter Output Power Rating (kW)

No. of Inverter(s)

Induction & Synchronous Based Systems

Manufacturer

Model (Name / Number)

Installation Information

Project Single Point of Contact: (Electric Utility Customer, Developer, or other)

Name:

Company (If Applicable):

Phone Number:

E-Mail Address:

Requested In Service Date:

Licensed Professional Engineer Name (If applicable)

Licensed Electrical Contractor Name (If applicable)

Electrical Contractor/PE Phone #:

Electrical Contractor/PE E-Mail:

Customer and Contractor Signature and Fees

Attached \$100 Interconnection Application Fee or

Attached \$100 combined Interconnection & Net Metering Program application fees
(\$75 Interconnection Application Fee plus \$25 fee required if selecting net metering)

(Check # / Money Order #)

(Sign and Return complete application with Application Fee to Electric Utility Contact)

To the best of my knowledge, all the information provided in this Application Form is complete and correct.

Customer

Project Developer/Contractor (If Applicable)

Note: Refer to the applicable "Michigan Electric Utility Generator Interconnection Procedures" for a detailed explanation of the Interconnection Process, Fees, Timelines, and

APPENDIXES

Appendix A: Technical Information for Synchronous-Type Generators
Appendix B: Technical Information for Induction-Type Generators
Appendix C: Sample Site Plan
Appendix D: Sample One-Line diagram for Inverter Type Project
Appendix E: Sample One-Line diagram for Synchronous Type Project
Appendix F: Sample One-Line diagram for Induction Type Project

Appendix A

Synchronous Generators

Generator Information

- a. Generator Nameplate Voltage
- b. Generator Nameplate W atts or Volt-Amperes
- c. Generator Nameplate Power Factor (pf)
- d. RPM

a.
b.
c.
d.

Technical Information

- e. Minimum and Maximum Acceptable Terminal Voltage
- f. Direct axis reactance (saturated)
- g. Direct axis reactance (unsaturated)
- h. Quadrature axis reactance (unsaturated)
- i. Direct axis transient reactance (saturated)
- j. Direct axis transient reactance (unsaturated)
- k. Quadrature axis transient reactance (unsaturated)
- l. Direct axis sub-transient reactance (saturated)
- m. Direct axis sub-transient reactance (unsaturated)
- n. Leakage Reactance
- o. Direct axis transient open circuit time constant
- p. Quadrature axis transient open circuit time constant
- q. Direct axis subtransient open circuit time constant
- r. Quadrature axis subtransient open circuit time constant
- s. Open Circuit saturation curve
- t. Reactive Capability Curve showing overexcited and underexcited limits (Reactive Information if non-synchronous)
- u. Excitation System Block Diagram with values for gains and time constants (Laplace transforms)
- v. Short Circuit Current contribution from generator at the Point of Common Coupling
- w. Rotating inertia of overall combination generator, prime mover, couplers and gear drives
- x. Station Power load when generator is off-line, W atts, pf
- y. Station Power load during start-up, W atts, pf
- z. Station Power load during operation, W atts, pf

e.
f.
g.
h.
i.
j.
k.
l.
m.
n.
o.
p.
q.
r.
s.
t.
u.
v.
w.
x.
y.
z.

Appendix B

Induction Generators

Generator Information

- a. Generator Nameplate Voltage
- b. Generator Nameplate W atts or Volt-Amperes
- c. Generator Nameplate Power Factor (pf)
- d.RPM

a.
b.
c.
d.

Technical Information

- e. Synchronous Rotational Speed
- f. Rotation Speed at Rated Power
- g. Slip at Rated Power
- h. Minimum and Maximum Acceptable Terminal Voltage
- i. Motoring Power (kW)
- j. Neutral Grounding Resistor (If Applicable)
- k. $I_2^2 t$ or K (Heating Time Constant)
- l. Rotor Resistance
- m. Stator Resistance
- n. Stator Reactance
- o. Rotor Reactance
- p. Magnetizing Reactance
- q. Short Circuit Reactance
- r. Exciting Current
- s. Temperature Rise
- t. Frame Size
- u. Design Letter
- v. Reactive Power Required in Vars (No Load)
- w. Reactive Power Required in Vars (Full Load)
- x. Short Circuit Current contribution from generator at the Point of Common Coupling
- y. Rotating inertia, H in Per Unit on kVA Base, of overall combination generator, prime mover, couplers and gear drives
- z. Station Power load when generator is off-line, W atts, pf
- aa. Station Power load during start-up, W atts, pf
- bb. Station Power load during operation, W atts, pf

e.
f.
g.
h.
i.
j.
k.
l.
m.
n.
o.
p.
q.
r.
s.
t.
u.
v.
w.
x.
y.
z.
aa.
bb.

Appendix C: Sample Site Plan - Provided for Reference Only

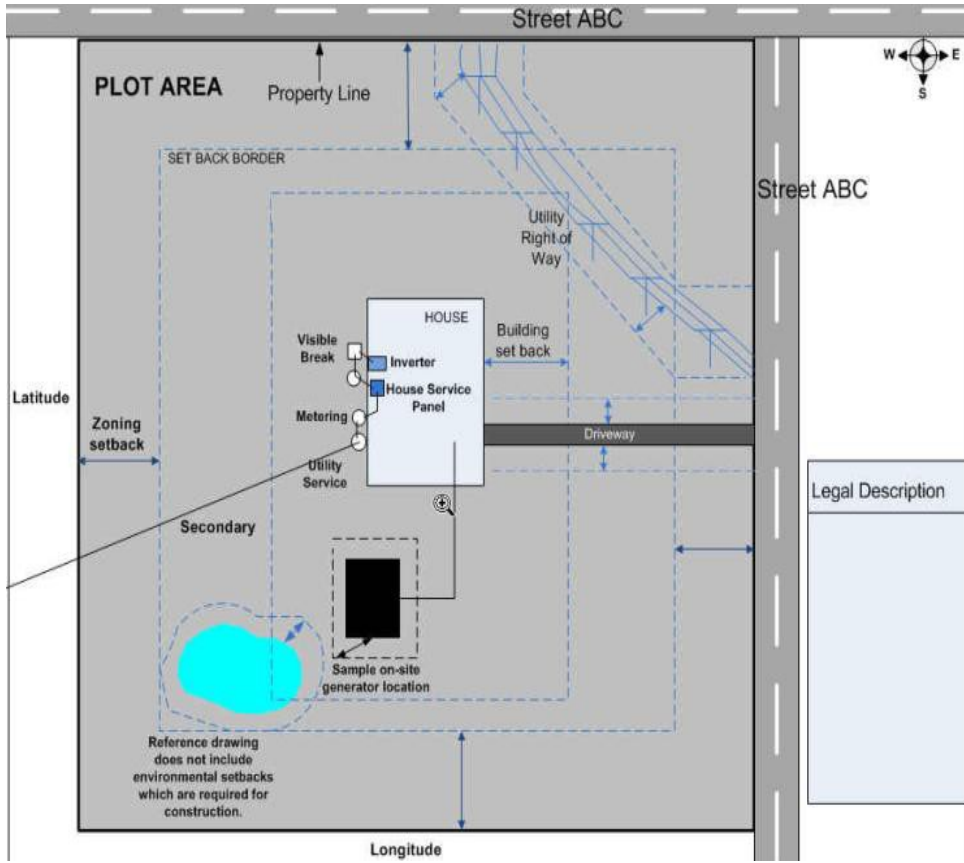

Customer Name: _____

Project Site Address: _____

Site Plan Prepared By: _____

Prepared Date: _____

Appendix D - Sample One Line Drawing for Net Metering Inverter Based Generators

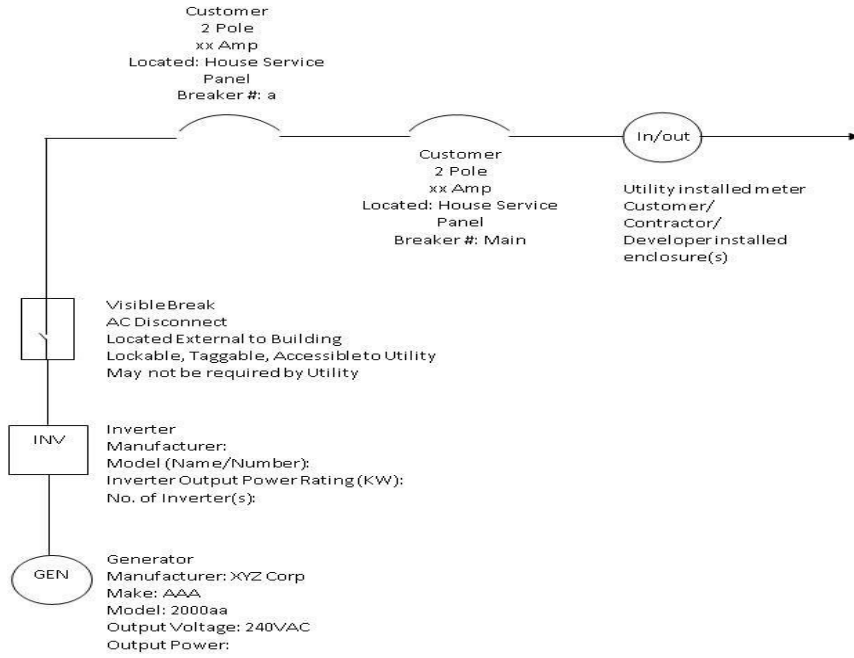

NOTE: One-line diagram must be signed and sealed by a licensed Professional Engineer, licensed in the State of Michigan or by an electrical contractor licensed by the State of Michigan

Customer Name: _____

Project Site Address: _____

Licensed Professional Engineer Name (If applicable): _____

Licensed Professional Engineer Signature: _____

Electrical Contractor License Number: _____

Date: _____

Appendix E: Sample One-Line Drawing for Synchronous Generators

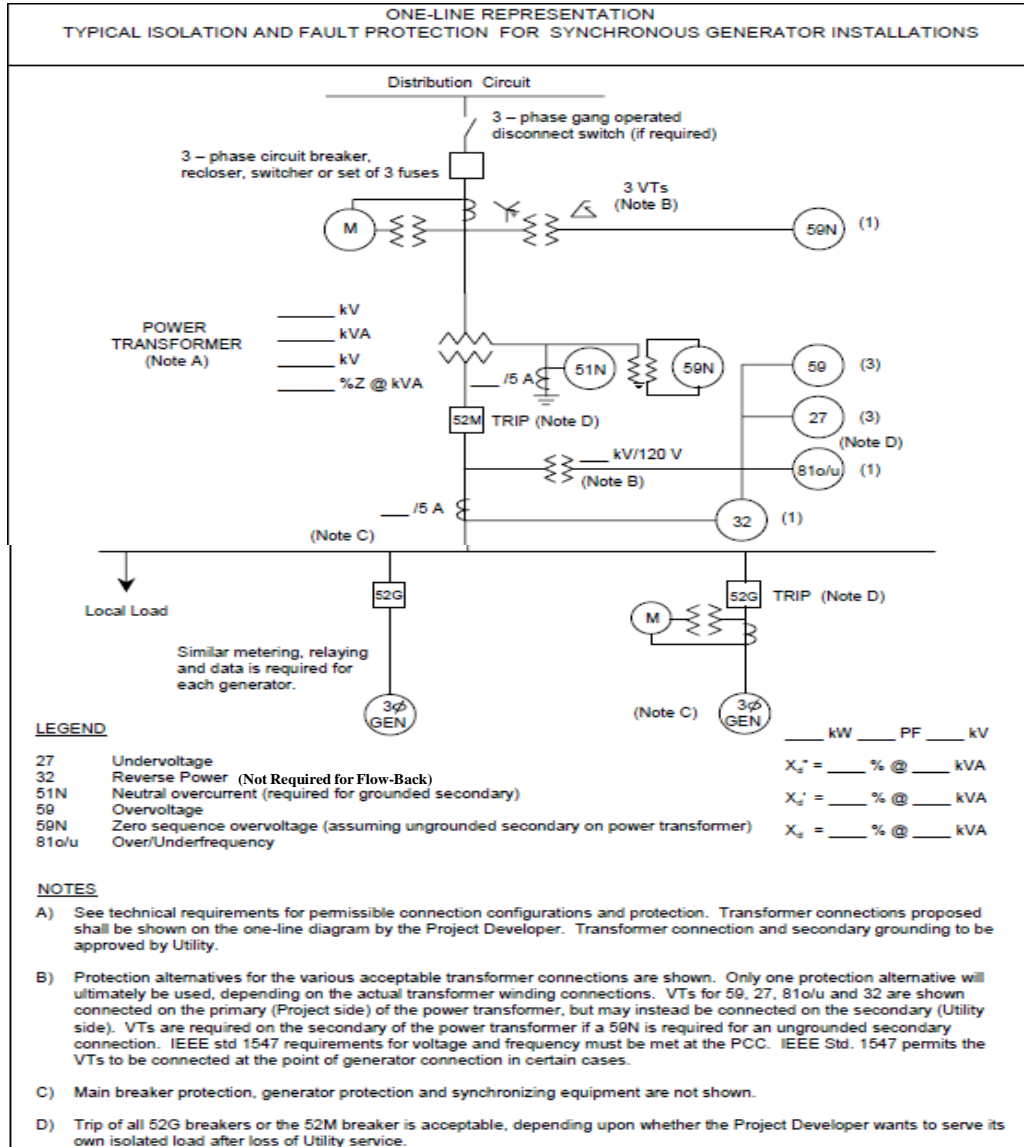

NOTE: One-line diagram must be signed and sealed by a licensed Professional Engineer, licensed in the State of Michigan or by an electrical contractor licensed by the State of Michigan

Customer Name: _____

Project Site Address: _____

Licensed Professional Engineer Name (If applicable): _____

Licensed Professional Engineer Signature: _____

Electrical Contractor License Number: _____

Date: _____

Appendix F: Sample One-Line Drawing for Induction Generators

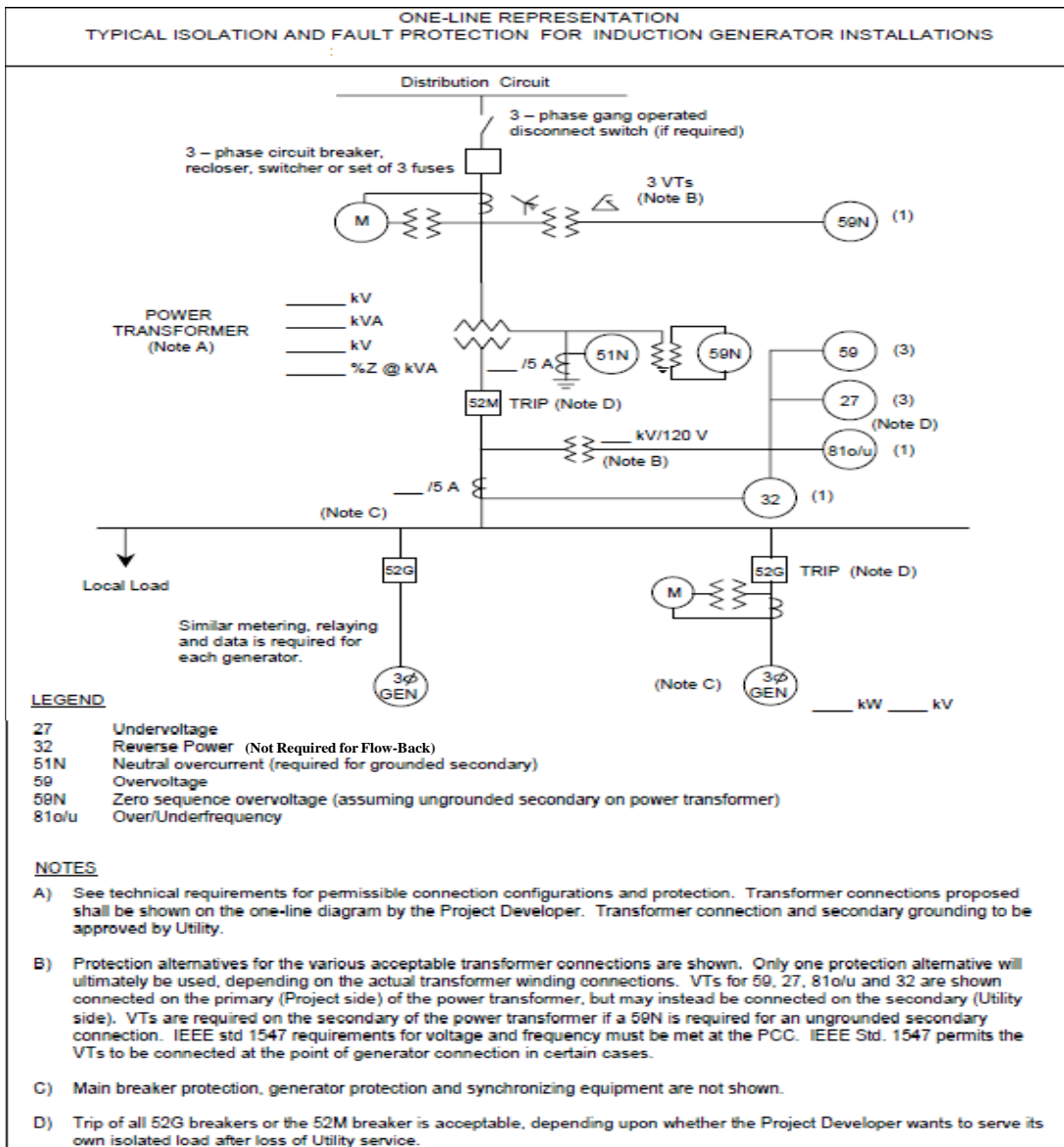

NOTE: One-line diagram must be signed and sealed by a licensed Professional Engineer, licensed in the State of Michigan or by an electrical contractor licensed by the State of Michigan

Customer Name: _____

Project Site Address: _____

Licensed Professional Engineer Name (If applicable): _____

Licensed Professional Engineer Signature: _____

Electrical Contractor License Number: _____

Date: _____