

STATE OF MICHIGAN



SCHOOL BUS INSPECTION MANUAL

SCHOOL BUS INSPECTION UNIT

Revision Date: 2013
Revision Number 1.8



INTRODUCTION

The purpose of the Commercial Vehicle Enforcement Division School Bus Inspection Manual is to provide guidance for the inspection of public and non-public school buses and pupil transportation vehicles. This document provides Commercial Vehicle Enforcement Division Vehicle Safety Inspectors with the criteria for the issuance of a red or yellow tag to a school bus to ensure the safety of pupil transportation in Michigan. The Michigan Department of State Police reserves the right to make changes in the manual when safety concerns have been identified or resolved.

Vehicles are to be maintained in a safe operating condition at all times. All maintenance and repairs shall be performed using parts and repair procedures that meet or exceed the applicable Federal Motor Vehicle Safety Standard.

THE MICHIGAN PUPIL TRANSPORTATION ACT (PA 187) REQUIRES:

MCL 257.1810 (1) Each school bus owned or operated by a public or private nonpublic school, an agent of a school, a private business, or a unit of government for the transportation of pupils to or from school or school-related events shall meet or exceed the federal motor vehicle safety standards applicable to the construction and sale of that school bus and for all seating positions in that vehicle. A school or an agent of a school may transport pupils with disabilities in mobile seating devices in accordance with federal standards specifically applicable to such pupils, their wheelchairs, and related wheelchair securement and occupant protection systems.

MCL 257.1839 (4) Any public or private entity that owns or uses a school bus for pupil transportation shall identify itself to the department of state police so an inspection can be scheduled. If an entity has had school buses inspected in the previous year, it is considered to have identified itself. If an entity stops pupil transportation in one year and restarts pupil transportation in a later year, it must identify itself to the department of state police as requiring inspection before restarting pupil transportation. An entity is considered to have identified itself by notifying a person of the Department of State Police responsible for conducting inspections under this act.

MCL 257.1839 (5) When an inspection is scheduled by the Department of State Police, an entity shall identify to the state police inspector all of the school buses that it intends to use for pupil transportation in that school year. Any school bus that is not submitted for inspection shall be rejected and have a red sticker affixed pursuant to section 41.

SCHOOL BUS INSPECTION MANUAL



The following reference documents have been used throughout the School Bus Inspection Manual:

[Act 187 of 1990 Michigan Pupil Transportation Act \(MCLA 257.1801– 1877\)](#)

[ACT 300 Michigan Motor Vehicle Code \(MCLA 257.1 - 923\)](#)

[ACT 300 Michigan Motor Vehicle Code \(MCLA 257.683 - 714 Equipment\)](#)

[49 CFR Code of Federal Regulations](#)

[49 CFR Part 393 Federal Motor Carrier Safety Standards](#)

[49 CFR Part 571 Federal Motor Vehicle Safety Standards](#)

[49 CFR Part 38 Americans with Disabilities Act \(ADA\)](#)

[National School Transportation Specifications and Procedures](#)

Questions regarding the inspection procedure and the use of the inspection manual may be directed to the commander of the State Support Section of the Michigan State Police Commercial Vehicle Enforcement Division, 333 S. Grand Avenue, Lansing, MI 48933, or by calling (517) 241-0506.



<u>TABLE OF CONTENTS</u>	<u>PAGE</u>
1.0 <u>BODY AND SHEETMETAL</u>	4
2.0 <u>BRAKE SYSTEM</u>	5
3.0 <u>CHASSIS, FRAME AND UNIBODY</u>	9
4.0 <u>EMERGENCY EXITS AND AISLES</u>	10
5.0 <u>ENGINE AND DRIVE TRAIN</u>	11
6.0 <u>EXHAUST SYSTEM</u>	11
7.0 <u>FUEL SYSTEMS</u>	11
8.0 <u>GLASS</u>	12
9.0 <u>LIGHTING AND ELECTRICAL</u>	12
10.0 <u>MIRRORS</u>	15
11.0 <u>MISCELLANEOUS EQUIPMENT</u>	15
12.0 <u>PAINT AND MARKINGS</u>	16
13.0 <u>PROHIBITED VEHICLES</u>	16
14.0 <u>SEATS AND BARRIERS</u>	16
15.0 <u>SERVICE DOOR</u>	18
16.0 <u>SPECIAL NEEDS EQUIPMENT</u>	18
17.0 <u>STEERING</u>	22
18.0 <u>SUSPENSION</u>	24
19.0 <u>TIRE, WHEEL AND HUB</u>	25
<u>APPENDIX</u>	
<u>BRAKE CHAMBER DATA</u>	27
<u>AIR BRAKE SYSTEM TEST PROCEDURE</u>	28
<u>SCHOOL BUS EXTERIOR MIRROR ADJUSTMENT GRID</u>	29
<u>ACKNOWLEDGEMENT</u>	30



1.0 BODY AND SHEET METAL

a) Body Condition Exterior: General

The body of the vehicle including the floor pan, roof bows, body panels, rub rails and braces shall be free from excessive rust, aligned and properly fastened to the frame with appropriate spacers and connectors. [49 CFR 571.220](#), [571.221](#), [571.222](#), [MCLA 257.1811](#).

(1) Condition Yellow Tag:

- (a) Non-manufactured hole larger than a nickel.
- (b) Floor has holes left from bolts being removed.
- (c) Three or more or two adjacent body spacers missing.
- (d) Body fasteners missing, loose or broken.
- (e) Body repair does not meet or exceed original design.

(2) Condition Red Tag:

- (a) Any school bus body part that is loose, torn, dislocated, or protruding from the surface of the bus, creating a hazard.
- (b) Any body component that is rusted through, cracked or broken that affects the structural integrity of the vehicle.
- (c) Any engine, battery or other doors that are not properly secured.
- (d) Any part of the step well or support structure is damaged.
- (e) Fender has been removed.

Hood

(1) Condition Yellow Tag:

- (a) One hood latch broken.

(2) Condition Red Tag:

- (a) All hood latches are broken.
- (b) Safety catch is broken on forward facing hood.

Undercoating [MCLA 257.1811 \(4\)](#)

(1) Condition Yellow Tag:

- (a) Repairs to buses must be undercoated as required.

(2) Condition Red Tag:

- (a) New buses only, if vehicle has not been undercoated as required.

b) Body Condition Interior: General [MCL 257.1811 \(4\);\(5\);\(8\)](#)

The interior of the vehicle shall be free from sharp, protruding objects or tripping hazards likely to cause injury.

(1) Condition Yellow Tag:

- (a) Floor including wheel housing, aisle, step well not covered in a slip resistant surface or in a condition that could present a hazard.

(2) Condition Red Tag:

- (a) Any panel (ceiling, side, wheel well, etc.) protruding, having sharp edges, or not secured, that may cause injuries.
- (b) Floor pan or inner panels have perforated areas or openings. Any floor or body panel opening through to the exterior of the vehicle.

c) Defrosters: General

Defrosting and defogging systems shall ensure driver visibility under adverse weather conditions. The device or auxiliary fans must keep the windshield, window at driver's left, and the glass in the service door clear of fog, frost, and snow. (49 CFR 571.103).



- (1) **Condition Red Tag:**
 - (a) Defrosting/defogging system that fails to operate.
- d) **Heaters:**
 - (1) **Condition Yellow Tag:**
 - (a) Heater core, heater hoses, or heater fittings are leaking.
 - (2) **Condition Red Tag:**
 - (a) Any heater fuel, electric, or hot water component that creates a safety hazard.
- e) **Radio Speakers Passenger Compartment: [MCLA257.1811](#)**
 - (1) **Condition Yellow Tag:**
 - (a) Any active or inactive radio speaker, except two way communication devices, closer than three seat positions behind the driver, extending the entire width of the bus.
 - (2) **Condition Red Tag:**
 - (a) Any new vehicle delivered into the state after 8/15/06 with speakers installed closer than three seat positions behind the driver, extending the entire width of the bus.
- f) **Overhead Storage (257.1811) (49 CFR 571.222)**

Any overhead storage compartment must comply with FMVSS 49 CFR 571.222. Book racks shall not be installed in a school bus.

 - (1) **Condition Yellow Tag:**
 - (a) Latches not working as designed.
 - (2) **Condition Red Tag:**
 - (a) Installation does not meet head protection requirements of 49 CFR No. 222.
 - (b) Storage compartment not completely enclosed and equipped with latching door.
 - (c) Corners and edges not rounded with a minimum radius of one inch or padded equivalent to door header padding.
 - (d) Not attached to the bus sufficiently to withstand a force equal to 20 times the maximum rated capacity of the compartment.
 - (e) Protrusion(s) greater than 1/4 inch.

2.0 **BRAKE SYSTEM**

Every school bus shall be equipped with brakes acting on all wheels. All brakes with which a school bus is equipped must at all times be capable of operating. (393.42), (393.48). The brake system shall comply with federal specifications applicable for the specific year of the vehicle.

[MCLA 257.1810](#)

- (1) **Condition Yellow Tag:**
 - (a) ABS light that fails to come on or go off per manufacturer's design.
- (2) **Condition Red Tag:**
 - (a) Absence of effective braking action upon application of the service brakes (such as any brake lining/pad failing to move or contact braking surface upon application).

NOTE: Brake Adjustment Limits. Bring reservoir pressure between 90 – 100 psi, turn engine off and then fully apply the brakes. All brake measurements shall be made in 1/8 inch increments.

- (1) **Condition Red Tag:**
 - (a) One brake at 1/4 inch or more beyond the adjustment limit.

(Example: Type 30 clamp air chamber pushrod measured at 2-1/4 inches would be one defective brake). (393.47(e))

- (b) Any wedge brake where the combined brake lining movement of both top and bottom shoes exceeds 1/8 inch. (393.47(f)).

a) Drum (Cam – Type and Wedge) Air Brakes

(1) Condition Red Tag:

- (a) Missing or broken brake shoe, lining, return spring (shoe or chamber), anchor pin, spider, cam roller, camshaft, pushrod, yoke, clevis pin, brake adjuster, parking brake spring, or air chamber mounting bolt. (393.48(a))
- (b) Loose air chamber, spider, or camshaft support bracket. (393.48(a))
- (c) Brake parts defective or worn beyond specifications.
- (d) Defective Lining Conditions:
 - (i) Lining cracks or voids that exceed 1/16 inch in width observable on the edge of the lining. (393.47(a))
 - (ii) Portion of a lining segment missing such that a fastening device (rivet or bolt) is exposed when viewing the lining from the edge. (393.47(a))
 - (iii) Crack that exceeds 1 – 1/2 inch in length. (393.47(a))
 - (iv) Loose lining segment. (Approximately 1/16 inch or more movement.) (393.47(a))
 - (v) Complete lining segment missing. (393.47(a))
 - (vi) The friction surface of the brake drum and the brake friction material are contaminated by oil, grease, or brake fluid. ****NOTE:** Refer to “Tire, Wheels, and Hubs” if wheel seal is actively leaking.
 - (vii) Lining thickness less than 1/4 inch or worn into the wear indicator if lining is so marked, measured at the shoe center. (393.47(d) (2))

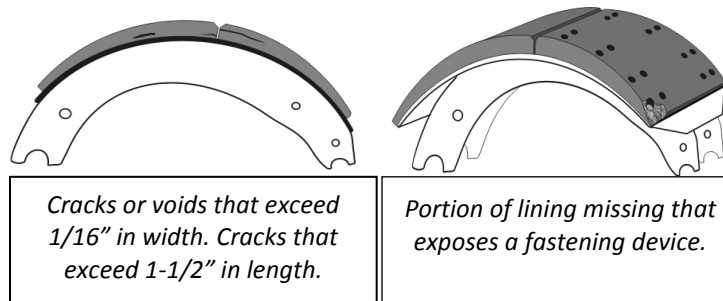

(e) Mismatched air chamber sizes. (393.47(b))

****NOTE:** Mismatched air chamber size excludes long stroke air chamber versus regular stroke air chamber and excludes differences in design type such as type 20 clamp versus type 20 roto-chamber. A bolt chamber with any other chamber type is a mismatch.

- (f) Mismatched brake adjuster length. (393.47(c))
- (g) Any vehicle manufactured after October 20, 1994 not equipped with automatic slack adjusters.
- (h) Spring Brake Chambers.
 - (i) Any non-manufactured holes or cracks in the spring brake housing section of a parking brake. (396.3(a) (1))



- (i) Parking Brakes
No brakes on the vehicle are applied upon actuation of the parking brake control, including driveline hand controlled parking brakes. *Checked at 1,100 rpm in drive.* A **Condition Yellow Tag** exists when pumping the service brake, dash valve fails to automatically activate parking brake(s) when the air gauge(s) read minimum of 20 psi and maximum of 40 psi.
- (j) Brake Drums or Rotors (Discs)
****NOTE:** Do not confuse short hairline heat check cracks with flexural cracks.
Any portion of the drum has any external crack, or has any crack that opens upon brake application. (393.47(a))
 - (i) Any drum worn beyond maximum diameter.
 - (ii) Any rotor (disc) with a crack in length of more than 1" to the open edge of the friction surface and passes completely through the rotor to the center vent from either side or completely through a solid rotor. (393.47(a))
 - (iii) A rotor surface is worn below minimum thickness. (393.47(g))
 - (iv) Any portion of the drum or rotor (discs) missing or in danger of falling away.
- (k) Brake Hose/Tubing
****NOTE:** Rubber impregnated fabric cover is not a reinforcement ply.
****NOTE:** Thermoplastic nylon tube may have braid reinforcement or color difference between cover and inner tube.
 - (i) Any damage extending through the outer reinforcement ply. (393.45(a))
 - (ii) Exposure of the second color.
 - (iii) Bulge/swelling when air pressure is applied. (393.45(a))
 - (iv) Audible air leak at Air Chamber. (Example: ruptured diaphragm, loose chamber clamp, etc.) (393.3(a) (1))
 - (v) Improperly joined such as a splice made by sliding the hose ends over a piece of tubing and clamping the hose to the tube. (393.45(a))
 - (vi) Damaged by heat, broken, or crimped in such a manner as to restrict air flow.
- (l) Air Pressure Gauge
 - (i) Inoperative or defective primary or secondary air pressure gauge. (393.51(c))
- (m) Low Air Pressure Warning Device
****Note: Condition Yellow Tag:** *If either an audible or visual warning device is not working as required.*
 - (ii) Low air pressure warning device missing, inoperative, or does not operate continuously if either the primary or secondary reservoir is 55 psi and below, or 1/2 of the governor cut-out pressure, whichever is less. (393.51)
- (n) Air Loss Rate
 - (i) If an air leak is discovered and either the primary or secondary reservoir pressure is not maintained when:
 1. Reservoir Pressure is 90 psi (minimum).
 2. Service brakes are fully applied.
 3. Air leaks, with brake applied or released, that exceed 3 psi per minute of air loss.
- (o) Air Reservoir (Tank)
 - (i) An air reservoir (tank) not secured at either end from the attachment point(s) or allowing movement more than one inch in any direction. (396.3(a) (1))
 - (ii) Any air tank mounting that does not meet the requirements of [257.1813](#).



- (p) Air Compressor (Normally to be inspected when readily visible or when conditions indicate compressor problems).
 - (iii) Loose compressor mounting bolts. (396.3(a) (1))
 - (iv) Cracked, broken, or loose pulley.
 - (v) Cracked or broken mounting brackets, braces, or adapters.
 - (vi) Proper build up time 50-90 psi within three minutes at fast idle; 1,100 rpm for diesel engines and 1,500 rpm for all other fuels.
- (q) Air Dryer (if equipped), or moisture ejectors.
 - (i) Air dryer or moisture ejectors that fail to exhaust or function per manufacturer's specification.
- (r) Valves.
 - (i) Any check valve, or system protection valve, not holding.
 - (ii) High pressure relief valve missing.
 - (iii) Inversion valve (brake modulating valve) not working as designed.
 - (vii) A **Condition Yellow Tag** exists if any valve is not properly mounted, but is in working condition.

b) Hydraulic Brakes

(1) Condition Yellow Tag:

- (a) ABS light that fails to come on or go off per manufacturer's design.

(2) Condition Red Tag:

- (a) The fluid level in any master cylinder reservoir is less than 1/4 full or below minimum marking. (396.3(a) (1))

****NOTE:** Normally to be inspected when readily visible or problems are apparent.

- (b) Hydraulic or vacuum lines, hoses or connections are restricted, crimped, broken or damaged through the outer reinforcement ply. (Restricted/crimped/broken – 393.45(a) or damaged – (393.45(b) (2))

****NOTE:** Rubber impregnated fabric cover is not a reinforcement ply.

- (c) Any observable seepage, bulge or swelling on a brake hose under application pressure. (393.45(a))
 - (i) Any observable leaking hydraulic fluid in the brake system upon full application. (393.45(a))
 - (ii) No pedal travel reserve with engine running upon full brake application. (393.40(b))
 - (iii) Brake power assist unit is inoperative. (396.3(a) (1))
 - (iv) Hydraulic power brake (HPB) unit is inoperative. (396.3(a) (1))
 - (v) Brake warning system is missing, inoperative, disconnected, defective, or activated while engine is running with or without brake application. (393.51(b))
 - (vi) The hydraulic brake backup system is inoperative. (396.3(a) (1))

c) Vacuum Brakes

(1) Condition Red Tag:

- (a) Insufficient vacuum reserve to permit one full brake application after engine is shut off. (393.50(b))
- (b) Vacuum hose(s) or line(s) restricted, abraded (chafed) through outer cover-to-cord ply, crimped, cracked, broken, or has collapse of vacuum hose(s) when vacuum is applied. (393.45(b) (2))

d) Hydraulic and Electric Brakes

(1) Condition Red Tag:

- (a) Missing or broken caliper, brake pad, shoe, or lining. (393.48(a))
- (b) Movement of the caliper within the anchor plate, in the direction of wheel rotation, exceeds 1/8 inches. (393.48(a))

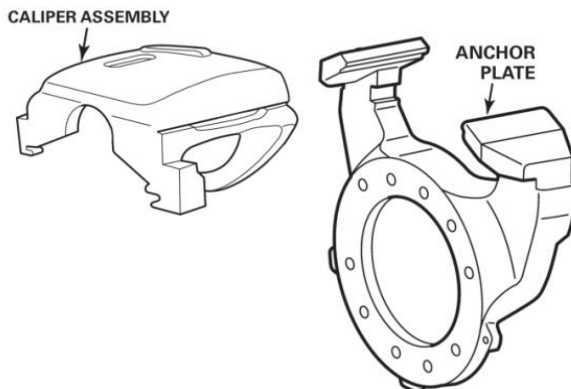
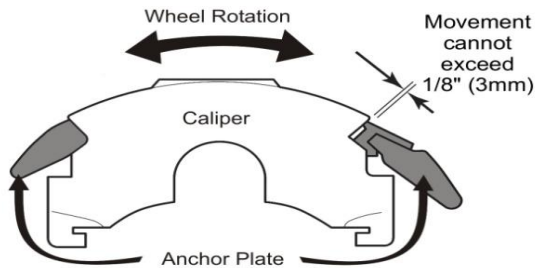

- (c) Rotor or drum has evidence of metal to metal contact on the friction surface. (393.47(d) (2))
- (d) Rotor has severe rusting on the rotor friction surface on either side (light rusting on the friction surface is normal). (393.48(a))
- (e) Friction surface of the brake rotor and the brake friction material are contaminated by oil, grease, or brake fluid. (393.47(a))

****NOTE:** Refer to "Tire, Wheels, and Hubs" if wheel seal is actively leaking.

- (f) Lining or pad with a thickness 1/8 inch or less for disc or drum brakes. (393.47(d) (2))

3.0 CHASSIS, FRAME AND UNIBODY

Frame, Cross Members, Outriggers, Body Support and Bumpers: General

(1) Condition Yellow Tag:

- (a) Missing or loose bolts on motor mount cross members.



(2) Condition Red Tag:

- (a) Missing or loose bolts on motor mount cross members sufficient to allow cross member to shift or move.
- (b) Any crack 1 1/2 inch or longer in frame side rail which is directed toward the bottom flange.
- (c) Any crack extending from the frame side rail web around the radius and into the bottom flange.
- (d) Any cracked, loose, sagging or broken frame side rail.
- (e) Any obvious bend or damage resulting from a collision.
- (f) Any worn or loose mounting hole.
- (g) Any cross member, outrigger or other structural support cracked, missing or deformed.
- (h) Any missing, broken, shifted or corroded part that would affect the safe operation of the vehicle.
- (i) Any bumper missing or not secured.

4.0 EMERGENCY EXITS AND AISLES

a) Emergency Exits: General

All emergency exits shall comply with the standards identified in [49 CFR 571.217](#) and [MCLA 257.1811 \(6\)\(a\) and \(b\)](#).

(1) Condition Yellow Tag:

- (a) Type I school bus does not have glass in both the upper and lower portion of the central rear emergency exit. Effective date August 15, 2006.
- (b) Prop-rod is missing or fails to hold door in open position.
- (c) Rear engine transit type bus exit opening assist cylinder fails to operate.
- (d) Emergency door seal is missing, loose, or doesn't make contact.
- (e) Operating instructions and or emergency exit identification is missing.
- (f) Any required window audible warning device that fails to function properly.

(2) Condition Red Tag:

- (a) Emergency door exit egress is reduced to less than 24"x 45" for a Type II bus, or 22"x 48" for a Type I bus.
- (b) Any emergency door, roof hatch or window that does not open freely or completely as designed.
- (c) Any required door (s) or rear exit window audible warning device that fails to properly function.
- (d) Piano hinges on emergency exit doors. MCLA 257.1811.
- (e) Any emergency exit fitted with locks or lock hasps or similar non-OEM locking device. (Excludes interlock system).
- (f) Emergency exit interlock system fails to operate as designed.
- (g) Any vehicle that lacks the required number of emergency exits as defined in [49 CFR 571.217](#).

b) Aisles: General [MCL 257.1811 \(10\)](#)

(1) Condition Red Tag:

- (a) Aisle does not have the required clearance.
- (b) There are objects blocking aisles or exits.



- (c) Any baggage, article, equipment or medical supplies not secured in a manner that assures unrestricted access to all exits.
- (d) Any baggage, broom, window scraper, trash receptacle or other article or equipment not secured in a manner that protects all occupants from injury.

5.0 ENGINE AND DRIVE TRAIN

a) Engine: General

(1) Condition Yellow Tag:

- (a) Any defective motor mount.

b) Engine and Drive Train: General

(1) Condition Red Tag:

- (a) Drive shaft guard is loose, missing or broken.
- (b) Any shifted engine.
- (c) Any critical component that fails to function as designed.
- (d) Any fluid leaks that would affect the safe operation of the engine.
- (e) Cracked differential housing.

6.0 EXHAUST SYSTEM

a) Exhaust: General

(1) Condition Yellow Tag:

- (a) Heat shield (if required) is missing or improper.
- (b) A clamp or bracket is loose or broken not resulting in compromised system integrity or securement. [MCLA 257.707\(3\)](#)
- (c) Any leak resulting from rust or a crack. (Some exhaust leaking around a proper connection is expected) [MCLA 257.707\(2\)](#)

(2) Condition Red Tag:

- (a) Loose, cracked or leaking manifold connection. (Some exhaust leaking around a proper connection is expected) [MCLA 257.707\(2\)](#)
- (b) Any part of the system that passes through the occupant compartment.
- (c) Any part of the exhaust system discharging under the chassis. Down spout (when used) cannot be located more than six inches forward of the rear most part of the bus, or side of the bus.
- (d) No part of the exhaust system of any motor vehicle shall be so located as to be likely to result in burning, charring, or damaging the electrical wiring, the fuel supply, or any combustible part of the motor vehicle.
- (e) Any petroleum based product leaking or leaks on the exhaust system. (IE: fire hazard)
- (f) A clamp or bracket is loose or broken resulting in compromised system integrity or securement.

7.0 FUEL SYSTEMS

Fuel Systems:

(1) Condition Red Tag:

- (a) Any fuel system with evidence of unrepaired leak at any point.
- (b) A fuel tank not securely attached to the vehicle.
- (c) A fuel system that fails to comply with [MCLA 257.1829](#).



- (d) Any fuel tank impact protection cage that fails to comply with FMVSS 301.
- (e) Any fuel door interlock system failure, if so equipped.

8.0 GLASS

a) Glass: General

All glass or plastic used in the vehicle must comply with applicable federal and state specifications. All glass shall be mounted using a full periphery of glazing material. Any unmarked glass must have documentation for use in the specific position.

[49 CFR 571.205](#), [571.217](#), [571.219](#), [MCLA 257.1827](#), [257.708a](#), [257.709](#).

(1) Condition Yellow Tag:

- (a) Glazed surfaces containing any stickers not permitted by law.
- (b) Use of unauthorized tinting material which limits vision.
- (c) Any cracks, chips or discoloration over one inch.

(2) Condition Red Tag:

- (a) Any glass not of approved type.
- (b) Driver's side area window(s) chips, clouding, or cracks that obscure the driver's vision.
- (c) Non-transparent material is used to replace glass.
- (d) Any sharp or exposed edges of glass.
- (e) Any missing window in the vehicle.
- (f) Every school bus windshield shall be free of discoloration or other damage in that portion thereof extending upward from the height of the topmost portion of the steering wheel, but not including a one inch border at the top and a one inch border at each side of the windshield or each panel thereof, except that discoloration and damage as follows is allowed:
 - 1. Coloring or tinting applied during manufacture, for reduction of glare.
 - 2. Any crack not over one inch long, if not intersected by any other crack.

b) Wipers and Washers: General

- i) Windshield wipers and washers shall comply with 49 CFR 571.103 and 571.104.

(1) Condition Yellow Tag:

- (a) Washers are inoperative.
- (b) One speed inoperative.

(2) Condition Red Tag:

- (a) Wipers fail to clean windshield or are inoperative.

9.0 LIGHTING AND ELECTRICAL [Act 300 257.683-704 \(Lighting Requirements\)](#)

a) Lighting Systems: General

All vehicles shall be equipped with lamps that provide adequate illumination of the roadway and enhance conspicuity of motor vehicles so that their presence is perceived and signals understood, in daylight, darkness and other conditions of reduced visibility. The location, number and color of all exterior lamps and signals shall be in conformance with current Federal Motor Vehicle Safety Standards found in [49 CFR Part 571](#) and in section 697, 698 of the Michigan Vehicle Code, 1949 PA 300, [MCL 257.698](#). LED lamps shall not be noted as defective if the lighting diodes illuminated meet the lighting standard. [MCL 257.697](#)



- b) Headlamps (MCLA 257.684, 257.685, 257.695, 257.698)
 - (1) **Condition Yellow Tag:**
 - (a) One or both high beam inoperative.
 - (b) One low beam inoperative.
 - (2) **Condition Red Tag:**
 - (a) Both low beams are inoperative.
- c) Turn Signal Lamps and Indicators

The turn signal operating unit on each vehicle shall be self-canceling by steering wheel rotation and capable of cancellation by a manually operated control. 49 CFR 571.108 SAE 589 4-64, 49 CFR 571.108 S5.7 SAE J1395 4-85, J590b 10-65, MCLA 257.697(b)

 - (1) **Condition Yellow Tag:**
 - (a) Turn signal that fails to cancel by steering wheel rotation.
 - (2) **Condition Red Tag:**
 - (a) Any turn signal lamp is inoperative.
- d) Hazard Lamps 49 CFR 571.108 S5.5, SAE J9101-66, and J945 2-66, MCLA 257.698a, MCLA 257.1815
 - (1) **Condition Red Tag:**
 - (a) Any lamp inoperative in the 4-way hazard warning system.
- e) Backup Lamps

Vehicles shall conform to the SAE Standard J593c Backup Lamps 2-68. 49 CFR 571.108 S5.3.1.5, MCLA 257.698(3)

 - (1) **Condition Yellow Tag:**
 - (a) Back up lamp inoperative.
- f) Tail Lamps /Stop Lamps

Vehicles less than 80 inches width whose GVWR is 10,000 pounds or less, shall be equipped with a high-mounted stop lamp as required by 49 CFR 571.108, MCLA 257.1815, 257.686, 257.697b.

 - (1) **Condition Yellow Tag:**
 - (a) Only one stop or tail lamp operative per side.
 - (2) **Condition Red Tag:**
 - (a) No operative stop lamps or tail lamps
 - (b) Vehicles less than 80 inches and under 10,000 pounds GVWR, with no high mounted stop lamp.
 - (c) Any tail or stop light that fails to comply with 49 CFR 571 or MCL 257.698.
- g) Clearance, Identification, Marker and Strobe Lamps 49 CFR 571.108, MCL 257.688, 257.698, 257.1815, 257.1831.
 - (1) **Condition Yellow Tag:**
 - (a) More than three clearance lamps; or combination of side marker and/or identification lamps are missing or fail to function.
 - (2) **Condition Red Tag:**
 - (a) Strobe lamps roof mounted on vehicles 10,000 pounds or more shall be mounted approximately six feet from the rear of the vehicle. (MCL 257.1831)
- h) Exterior Lens/Color MCLA 257.689 257.690, 257.691, 257.1815
 - (1) **Condition Yellow Tag:**
 - (a) Exterior lens missing on any lamp.
 - (b) Wrong color of illumination on vehicle.



i) School Bus Signal Lamps: General

Each school bus shall be equipped with a system of either four red signal lamps that conform to SAE Standard J887 or both red and amber lamps installed in accordance with SAE Standard J887; except that each amber signal lamp shall be located near each red signal lamp, at the same level, but closer to the vertical centerline of the bus. The system shall be wired so that the amber signal lamps are activated only by manual or foot operation, and if activated, are automatically deactivated and the red signal lamps automatically activated when the bus entrance door is opened. 49 CFR S5.1.4, (a), (b), (i), (ii), [MCLA 257.1817, 257.1819](#)

j) Four and Eight Light Systems

(1) Condition Yellow Tag:

- (a) Indicator light inoperative.
- (b) Red/Yellow system indicator lamps inoperative.

(2) Condition Red Tag:

- (a) Red overhead flashing lamps are connected to service door or brakes.
- (b) Any overhead flasher lamp that is inoperative.
- (c) Any overhead flasher that does not alternate or operate sequentially as required.
- (d) Any crossing gate wired into a four light system.
- (e) Any light system with less than equivalent to a 7" signal.

**NOTE: Lamps indicating alternating flashing light operation shall be visible to the driver when in a normal seated position; [MCLA 257.1817](#). An exterior light monitor board is not required.

k) Stop Arm/Crossing Control Devices

Each school bus shall be equipped with a stop signal arm meeting the requirement of [49 CFR 571.131](#) S5.1 through S5.5.

(1) Condition Yellow Tag:

- (a) One lamp burned out.
- (b) Lamps flash when sign is in closed position.

(2) Condition Red Tag:

- (a) Stop arm will not extend or retract.
- (b) Both red lamps are inoperable or out of sequence.
- (c) Sign is defaced and unreadable.
- (d) A series of LED lamps fail to illuminate rendering a portion of the sign unreadable.
- (e) Stop sign extends when amber lamps are activated.
- (f) Any mounting of the sign that fails to comply with Federal Motor Vehicle Safety Standards.
- (g) If equipped, any crossing control device that fails to properly function.

l) Electrical: General

All wiring shall conform to current applicable recommended SAE practices.

(1) Condition Red Tag:

- (a) Any required wire or electrical component charred or showing evidence of being burnt or exposed.
- (b) Wiring is exposed or loose.



m) Alternator

(1) Condition Yellow Tag:

- (a) Belts are worn, loose or missing.
- (b) Less than 100 ampere rating. [MCLA 257.1811\(9\)](#).

n) Battery

(1) Condition Yellow Tag:

- (a) Less than cranking capacity 500 CCA for gasoline engines, 900 CCA for diesel engine [MCLA 257.1811 \(9\)](#).

(2) Condition Red Tag:

- (a) Wiring is exposed or loose.
- (b) Battery will not activate the starter.
- (c) Battery not secured.

o) Neutral Safety Switch

(1) Condition Red Tag:

- (a) Engine starter operative when the transmission shift position is in a forward or reverse drive position. (Applies to automatic transmissions only) [49 CFR 571.102](#).

p) Horn [MCLA 257.706](#)

(1) Condition Yellow Tag:

- (a) Horn operation intermittent.

(2) Condition Red Tag:

- (a) Horn button fails to be located and function as designed.
- (b) Fails to operate.

10.0 MIRRORS

a) Mirrors: General

All vehicles shall comply with the unobstructed vision requirement specified in [49 CFR 571.111](#).

(1) Condition Yellow Tag:

- (a) Mirrors shall be mounted on a stable support.
- (b) Mirrors cracked or clouded to the extent that rear vision is obscured.

(2) Condition Red Tag:

- (a) Any required mirror missing or broken.
- (b) Fails to meet the field of vision standards of [257.1823](#).
- (c) Mirrors have sharp edges.
- (d) Any mirror that will not hold a set adjustment.
- (e) Driver interior mirror fails to comply with 257.1823.

b) Sun Visors

Sun visors should not be bent, broken or loose. Visors should be capable of remaining in a set position.

(1) Condition Yellow Tag:

- (a) Broken sun visor.

11.0 MISCELLANEOUS EQUIPMENT

a) Add on Equipment:

(1) Condition Red Tag:

- (a) Any add on equipment that presents a safety hazard.



- b) First Aid Kits, Fusees, Reflectors and Fire Extinguisher [MCLA 257.1825, 257.681](#)
 - (1) **Condition Yellow Tag:**
 - (a) First aid kit is missing, or not securely fastened.
 - (b) Fusees, or reflective triangles missing, inaccessible or not secured in driver's area.
 - (2) **Condition Red Tag:**
 - (a) Any required fire extinguisher which is missing, not of proper type, size, not fully charged, has no pressure gauge, is not secured or is not accessible to the driver.
- c) State Issued Decal(s)/Registration
 - (1) **Condition Red Tag:**
 - (a) Any vehicle placed out-of-service or sold that displays any MSP decal. [257.1841](#)
 - (b) No valid registration or proof of insurance, when required.

12.0 PAINT AND MARKINGS

- a) Paint: General

A school bus used to transport pupils to and from school and/or school related events shall be painted in compliance with [MCLA 257.1833](#).

 - (1) **Condition Red Tag:**
 - (a) School bus as defined painted in a color configuration other than specified.
 - (b) School name improperly painted on the vehicle.
 - (c) Any multifunction school activity bus painted in the color configuration specified in MCL 257.1833 (1).
- b) Markings: General

Animal pictures, cartoon figures, and similar insignia may be affixed to the bus in a temporary manner. (MCLA 257.1833)

 - (1) **Condition Red Tag:**
 - (a) Any insignia, advertisement, stickers or markings other than specified by statute.

13.0 PROHIBITED VEHICLES

- a) All vehicles eleven passengers or more must be built to school bus specifications. [257.1807](#)
 - (1) **Condition Red Tag:**
 - (a) Any vehicle used for the transportation of pupils to or from school or school related events eleven passengers or more not built to school bus specifications.
- b) Motor Coach:
 - (1) **Condition Red Tag:**
 - (a) A school, as defined in Public Act 451 that owns a motor coach used in the transportation of pupils to or from school or any school-related event.
- c) Multifunction School Activity Bus (MFSAB):
 - (1) **Condition Red Tag:**
 - (a) Any MFSAB that was not built to the Federal Motor Carrier Safety Standards defined in 49 CFR and manufactured after September 2, 2003.

14.0 SEATS AND BARRIERS

- a) Passenger Seating: General

Each vehicle shall meet or exceed the federal motor vehicle safety standards applicable to the construction and sale of that vehicle and for all seating positions in that vehicle. A school may



transport pupils with disabilities in mobile seating devices in accordance with federal standards specifically applicable to such pupils. [49 CFR 571.222](#), [MCLA 257.1810](#)

b) Stanchions – (when required)

(1) Condition Yellow Tag:

- (a) Any looseness is detected, or fastening parts are missing.
- (b) Padding is missing.

(2) Condition Red Tag:

- (a) Stanchion is missing or presents a snagging hazard.

c) Seat Frames and Barriers

(3) Condition Yellow Tag:

- (a) Seat bottom assembly can be detached from frame.

(4) Condition Red Tag:

- (a) Non-manufacturer installed seating next to any lift gate door. ****Note: Seat barrier may be next to any lift gate door.**
- (b) Any seat or barrier that is not properly secured.
- (c) Frame broken or loose from floor or sidewall.
- (d) Metal seat assembly back broken.
- (e) Any cracked or broken seat bottom.
- (f) Seat or barrier spacing fails to comply with 49 CFR 571.222.

d) Seat Foam and Upholstery 49 CFR 571.222

(1) Condition Yellow Tag:

- (a) Foam is not symmetrical on each seat. Questionable seats will be physically checked before being tagged.
- (b) A tear, cut, or hole in the seat cover in excess of three inches.

(2) Condition Red Tag:

- (a) Seat back not protected by foam.
- (b) Foam split or displaced leaving top bar exposed.
- (c) Missing seat back or seat bottom cover.
- (d) Any seat or barrier material so defective that it compromises the integrity of occupant protection and compartmentalization.

****NOTE:** Seat back foam shall be maintained in good state of repair as not to be capable of feeling seat frame due to seat foam breakdown.

e) Driver Seat and Seat Belt

(1) Condition Yellow Tag:

- (a) All seat anchor bolts are not securely fastened to the floor.
- (b) Sheet metal and back is loose.
- (c) Seat belt webbing is frayed, split, or torn. Buckles do not properly operate. Belt anchorages are loose or badly corroded.
- (d) Belt mounting surfaces are badly deformed, damaged or corroded.

(2) Condition Red Tag:

- (a) Seat frame is loose, broken or cracked.
- (b) Mismatched seat and seat belt assembly.
- (c) Seatbelt fails to adjust or hold proper adjustment. ([393.93.](#))
- (d) Any part of the driver's safety restraint assembly is missing, not properly installed or so defective as to prevent proper securement.



15.0 SERVICE DOOR

a) Service Door: General

(1) Condition Yellow Tag:

- (a) Flexible material on vertical closing is defective.
- (b) Door is not maintained as manufactured.

(2) Condition Red Tag:

- (a) Door fails to operate manually.
- (b) Door does not open or properly close.
- (c) Door control handle does not lock in the closed position.
- (d) Door is equipped with a padlock or similar non-OEM locking device. (Excludes vehicles equipped with an interlock system)

b) Handrails Service Door: General

(1) Condition Red Tag:

- (a) Any missing required handrail.
- (b) Any handrail improperly installed or loose.
- (c) Any handrail that fails the nut/drawstring test.

16.0 SPECIAL NEEDS EQUIPMENT

a) Wheelchair Tie down and Occupant Restraint System (WTORS): General

The WTORS shall be designed, installed, and operated to accommodate passengers in a forward facing orientation and shall comply with all applicable requirements.

(1) Condition Red Tag:

- (a) Any vehicle manufactured after 1/17/94 with a side facing securement system. 49 CFR 571.222 S5.4.1.2

All vehicles retrofitted shall comply with all applicable requirements and standards. (49 CFR 571.222 S5.4.1 through S5.4.4, [49 CFR 38.21](#))

(1) Condition Red Tag:

- (a) Any non-compliant retrofitting of a vehicle. (49 CFR 571.222)

Mobility devices shall be affixed to the vehicle in such a manner that no exit or aisle is blocked in the vehicle.

(2) Condition Red Tag:

- (a) Any device installed that impedes any aisle or exit. (49 CFR 571.217)
- (b) Any oxygen cylinder secured to a wheelchair that impedes access to any exit.

The WTORS system shall be complete as dynamically tested by the manufacturer. Installation shall be in compliance with manufacturer's recommendations and shall meet all the requirements of 49 CFR 571.222.

(3) Condition Red Tag:

- (a) When in use any mismatched or missing securement system part; anchor point, anchorage, end fitting, belt, strap, fasteners, four-point tie down, four-point strap type tie down, or wheelchair lockdown device or system.
- (b) Wheelchair securement missing or improperly installed, loose or damaged.



All securement and restraint system hardware and components shall be free of sharp or jagged areas and shall be of a non-corrosive material or treated to resist corrosion in accordance with 49 CFR 571.201, 209.

(4) Condition Red Tag:

- (a) Any component having any sharp or jagged edge.
- (b) Use of a bungee cord in the WTORS system.
- (c) Securement, seat belt assembly, tracking or tie down device using a bungee cord when WTORS is in use.

Each WTORS location shall consist of minimum of four anchorage points. Two points shall be located in front and two in the rear. The anchorage shall be attached to the floor of the vehicle.

(5) Condition Red Tag:

Less than four anchorage points for any wheelchair tie down. (49 CFR 571.222 S5.4.1.2) Each WTORS device (webbing or strap assembly) shall provide a means of adjustment to remove slack. The system should not allow for more than a 2" movement in any direction under normal driving conditions. [49 CFR 38.23.](#)

(6) Condition Red Tag:

- (a) When in use any frayed, rusted, cut, or inoperable slack adjuster. 49 CFR 517.222.

All buses equipped with attachment points securement devices and/or wheelchair securement system shall also be equipped with a durable webbing cutter having a full width hand-grip and protected blade. The cutter must be appropriately stored in the driver's compartment within the drivers reach.

(7) Condition Red Tag:

- (a) No belt cutter accessible to the driver and/or aide as noted.

b) Aisles: General

All school buses equipped with a power lift or a lift door shall provide a 30" aisle leading from any wheelchair/mobility aid position to at least one emergency exit and the lift area. [ADA Accessibility Guidelines A4.2.1 \(3\)](#)

(1) Condition Red Tag:

- (a) Aisle width less than 30" if equipped with a lift or lift door.
- (b) No access to both the lift and at least one emergency exit.

No wheelchair station or component thereof can impede any aisle or the exit of any individual transported in the vehicle.

(2) Condition Red Tag:

- (a) Impeding an emergency exit.
- (b) Station securement system in aisle way.

c) Seating for Vehicles with Special Adaptive Equipment: General

All vehicles shall maintain compartmentalization where normal seating positions are present 49 CFR 571.222.

(1) Condition Red Tag:

- (a) Compartmentalization is incomplete, or a barrier or stanchion is removed.
- (b) Improper seat spacing.
- (c) Any seat that is rear or side facing that fails to comply with all the provisions of 49 CFR 571.222.



All seating and securement systems shall meet the federal standards for school bus passenger seating and crash protection, seat belt assemblies, seat belt assembly anchorages, and child restraint systems where applicable. 49 CFR 571.222, 209, 210, 213, 225, Head Start Regulations 2001. Seating adjacent to special needs lift doors is prohibited. **NOTE: See Seats and Barriers. If special needs lift is removed, door shall be secured with high grade bolt in locking mechanism.

(2) Condition Red Tag:

- (a) Seat belt, car seat and/or harness that fail to meet Federal Motor Vehicle Safety Standards.
- (b) Any securement of a person, car seat, seat belt, or harness that uses a bungee cord.

d) **Power Lifts and Ramps: General**

No vehicle shall have a lift door where a lift is pending installation or removed when the door is not closed, sealed, and the handle removed.

(1) Condition Red Tag:

- (a) Door not sealed and secured per manufacturer's instructions.
- (b) Door not secured to prevent opening.

Installation of all lifts in new and retrofitted vehicles shall be in compliance with all written manufacturer specifications. All equipment shall be used as dynamically tested. Maintenance of the equipment shall be per manufacturer's specifications. [ADA Accessibility Guidelines 192.23](#), [49 CFR 38.23](#), [49 CFR 37](#).

(2) Condition Yellow Tag:

- (a) Required components are improperly mounted.
- (b) Any incomplete installation of lift equipment.
- (c) The lift door cannot be secured in the open position.
- (d) The lift door seal is loose or missing.

(3) Condition Red Tag:

- (a) Lift installation damaged the structural integrity of the vehicle.
- (b) Any working part missing or inoperable (cables, pulleys, shaft, etc.).
- (c) Any broken weld or damaged pivot point.
- (d) Wheelchair lift does not function as designed or is inoperative.

e) **Lift Design and Operation: General**

The design load of the lift shall be at least 600 pounds. The lifting mechanism and platform shall be capable of lifting a minimum of 800 pounds. The lift shall not fold while the lift is in motion from the surface of the ground to vehicle level. The lift shall deploy to all levels, ground, curb, and intermediate positions. The lift shall incorporate an emergency method of deploying to ground level with a lift occupant, and raising and stowing the empty lift if the power to the lift fails. Lift design shall prevent excessive pressure that could damage the lift system when the platform is fully lowered or raised. Lift design shall prevent any jacking of the vehicle. (49 CFR 38)

(1) Condition Red Tag:

- (a) Wheelchair lift does not function as designed or is inoperative.
- (b) Any hydraulic line leaking during lift operation.
- (c) Lift folds while in motion.
- (d) Manual over ride system missing or inoperative.
- (e) Lift system damaged due to excessive loads.
- (f) Lift jacks vehicle in any position loaded or unloaded.



Controls shall be provided that enables the operator to activate the lift mechanism from either inside or outside the vehicle. All controls and emergency operation shall be ADA compliant and complete as provided by the manufacturer. Interlock systems (required as of April 1, 2005) combined in the control shall prove appropriate mechanisms or systems to ensure the vehicle cannot be moved when the lift is deployed. (49 CFR 571.403) (49CFR38).

(1) Condition Red Tag:

- (a) Controls missing or inoperative from inside or outside of the vehicle.
- (b) Incomplete controls as provided by manufacturer.
- (c) Interlock system fails to operate as designed.

f) Platform and Platform Gaps: General

The surface of the platform shall be free of any protrusions over 1/4" high. All platforms shall be slip resistant. (49 CFR 38)

(1) Condition Red Tag:

- (a) Platform surface has any protrusion that exceeds 1/4".

The platform surface shall have a minimum of 30" clear width measured from 2" above the platform surface to 30" above the surface of the platform. The clear length of the platform shall be a minimum of 48" measured 2" above the platform to 30" above the surface of the platform. (49 CFR 571.403, 404)

(1) Condition Red Tag:

- (a) Platform size less than 30x48 when measured 2" above surface.

Any openings between the platform surface and the raised barriers shall not exceed 5/8" in width. A gap between the lift and bus body shall not be greater than 1/2" in width. (49 CFR 38)

(1) Condition Red Tag:

- (a) Gap between surface and raised barriers in excess of 5/8"
- (b) Gap between lift and body greater than 1/2"

g) Barriers: General

The lift platform shall be equipped with barriers to prevent any of the wheels of a wheelchair or mobility aid from rolling off the platform during its operation. A moveable barrier or inherent design feature shall prevent a wheelchair or mobility aid from rolling off the edge closest to the vehicle until the platform is in its fully raised position. The loading edge barrier which functions as a loading ramp at ground level, shall be sufficient when raised or closed, or a supplementary system shall be provided, to prevent a power wheelchair or mobility device from riding over or defeating it. The lift shall permit both inboard and outboard facing wheelchairs and mobility aid users. (49 CFR 38)

(1) Condition Red Tag:

- (a) Lift gate lip does not lock when lift is in the air.
- (b) Incomplete or insufficient barriers to prevent roll off in any direction.
- (c) Lift gate lip does not automatically release when lift is on the ground.

h) Handrails: General

Handrails shall move in tandem with the lift and shall be graspable and provide support to standees throughout the entire lift operation. (49 CFR 38)

(1) Condition Red Tag:

- (a) Handrails fail to move in tandem with the lift or fail to provide support for standees.



Handrails shall be capable of withstanding a force of 100 pounds concentrated at any point on the handrail. (49 CFR 38)

(1) Condition Red Tag:

- (a) Damage to handrails due to excessive force.

i) Medical Support Equipment: General

(1) Condition Red Tag:

- (a) Any equipment carried in the vehicle that is not properly secured, creating a hazard.

17.0 STEERING

a) Steering: General

Steering Shaft and Travel

(1) Condition Yellow Tag:

- (a) Steering stops allow tire to rub on frame, metal or other chassis part.
- (b) Missing steering stop.

(2) Condition Red Tag:

- (a) Any fabric joint or steering gear where the direct connection between the two halves is not continuous.
- (b) Front wheels are incapable of being turned to right and left; steering stops without binding or interference.
- (c) Any modification or other condition that interferes with free movement of any steering component.

b) Steering Wheel Free Play: When any of these values (inch movement or degrees) are met or exceeded. For power steering systems, engine must be running.

(1) Condition Red Tag:

- (a) Any steering wheel free play that exceeds the chart below.

<u>Steering Wheel Diameter</u>	<u>Manual System Movement 30</u>	<u>or</u>	<u>Power System Movement * 45</u>
	<u>degrees</u>		<u>degrees</u>
16"	4-1/2"		6-3/4"
18"	4-3/4"		7-1/8"
19"	5"		7-1/2"
20"	5-1/4"		7-7/8"
21"	5-1/2"		8-1/4"
22"	5-3/4"		8-5/8"

For power systems, if the steering wheel movement exceeds 45 degrees before the steering axle tires move, proceed as follows:

- Rock the steering wheel left to right between points of power steering value resistance.
- If that motion exceeds 30 degrees or the inch movement values shown for manual steering, the vehicle will be red tagged.

c) Steering Column

(1) Condition Red Tag:

- (a) Any absence or looseness of U-bolt(s) or positioning part(s).
- (b) Worn, faulty, or obvious repair-welded universal joint(s).
- (c) Steering components when not properly secured.
- (d) Telescopic steering column does not lock into position.
- (e) Tilt steering column does not lock in at least one position.



- d) Front Axle Beam and All Steering Components other than Steering Column, Including Hub
 - (1) Condition Red Tag:**
 - (a) Any crack(s).
 - (b) Any obvious welded repair.
- e) Steering Gear Box/Rack & Pinion
 - (1) Condition Yellow Tag:**
 - (a) Any torn Boot
 - (1) Condition Red Tag:**
 - (a) Any mounting bolt(s) loose or missing.
 - (b) Any crack in gearbox or mounting brackets.
 - (c) Any obvious welded repair.
 - (d) Any looseness of the yoke-coupling to the steering gear input shaft.
- f) Pitman Arm
 - (1) Condition Red Tag:**
 - (a) Any looseness of the Pitman arm on the steering gear output shaft.
 - (b) Any obvious welded repair.
- g) Power Steering
 - (1) Condition Red Tag:**
 - (a) Auxiliary power assist cylinder loose.
 - (b) Power steering pump inoperative.
 - (c) Any faulty fluid control device, leak or empty reservoir.
- h) Ball and Socket Joints
 - (1) Condition Red Tag:**
 - (a) Any movement under steering load of a stud nut.
 - (b) Any motion, other than rotational, between any linkage member and its attachment point of more than 1/8 inch.
 - (c) Any obvious welded repair.
- i) Tie Rods and Drag Links
 - (1) Condition Yellow Tag:**
 - (a) Any motion, other than rotational, between any linkage member and its attachment point more than 1/16 inch, but **LESS** than 1/8 inch, measured using hand pressure.
 - (2) Condition Red Tag:**
 - (a) Any motion, other than rotational, between any linkage member and its attachment point of **MORE** than 1/8 inch measured using hand pressure.
 - (b) Loose clamp(s) or clamp bolt(s) on tie rods or drag links.
 - (c) Any looseness in any threaded joint.
- j) Nuts, Cotter Pins or other Devices
 - (1) Condition Red Tag:**
 - (a) Loose or missing fasteners on tie rod, Pitman arm, drag link, steering arm, or tie rod arm.
- k) Front Wheel Bearings
 - (1) Condition Red Tag:**
 - (a) Excessive wheel bearing play that exceeds OEM specifications.
- l) King Pin
 - (1) Condition Red Tag:**
 - (a) If measurement is found to be in excess of 1/4 inch.

- (b) Collapsed thrust washer and/or bearing.

18.0 SUSPENSION

a) Suspension: General

Axle Parts/Members

(1) Condition Red Tag:

- (a) Any U-bolt(s) or other spring to axle clamp bolt(s) cracked, broken, loose, or missing.
- (b) Any axle, axle housing, spring hanger(s), or other axle positioning parts(s) cracked, broken, loose, or missing resulting in shifting of an axle from its normal position.
- (c) Ball joint seals shall not be cut or cracked, other than superficial surface cracks. Ball joints and kingpins shall not be bent or damaged. Stabilizer bars shall be connected. Springs shall not be broken and coil springs shall not be extended by spacers. Shock absorber mountings, shackles, and U-bolts shall be securely attached. Rubber bushings shall not be cracked, extruded out from or missing from suspension joints. Radius rods shall not be missing or damaged.

b) Spring Assembly

(1) Condition Yellow Tag:

- (a) Less than one-fourth of the leaves in any spring assembly broken.

(2) Condition Red Tag:

- (a) One-fourth or more of the leaves in any spring assembly broken.
- (b) Any coil spring broken.
- (c) Any leaf or portion of any leaf in any spring assembly is missing or separated.
- (d) Any broken main leaf in a leaf spring.

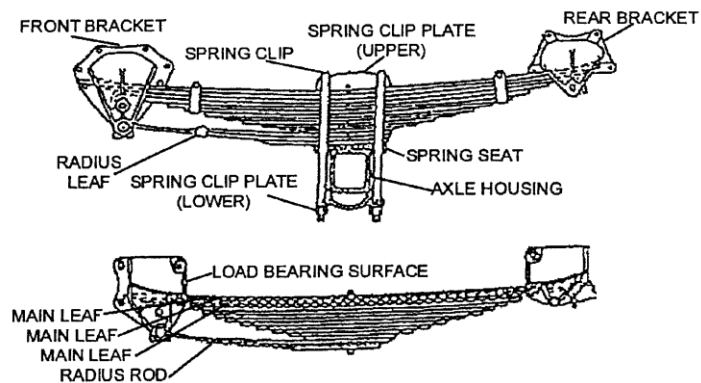

c) Torque, Radius, or Tracking Components

(1) Condition Red Tag:

- (a) Any part of a torque, radius, tracking component assembly, or any part used for attaching same to the vehicle frame or axle that is cracked, loose, broken, or missing. This includes spring leaves used as a radius or torque rod that are missing a bushing, but does not include loose bushings in torque or track rods.

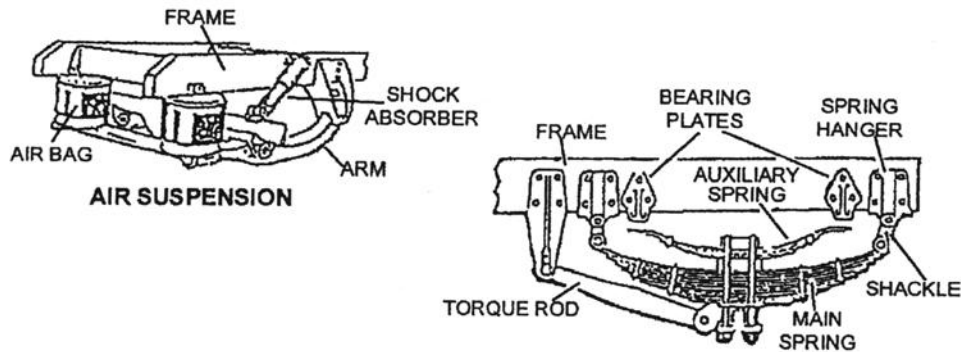

d) Air Suspension

(1) Condition Red Tag:

- (a) Deflated air suspension (one or more deflated air spring/bag).
- (b) Air spring/bag is missing or is detached at the top or bottom.

19.0 TIRE, WHEEL AND HUB

a) Tires: General Condition

Tires shall be free from chucking, bumps, knots, or bulges evidencing cord, ply or tread separation from the casing.

(1) Condition Red Tag:

- (a) Any sidewall cut, worn or damaged to the extent that the ply cord is exposed. [49 CFR 570.62 \(c\), \(d\)](#)
- (b) Any observable bump, bulge or knot related to sidewall or tread separation. (49 CFR 570.62)
- (c) Any unrepaired fabric break or any fabric break that has been repaired with a blowout patch. Any visible boot, rim crack, ply repair, or plugged sidewall. (49 CFR 396 Subpart (b))

The tread shall not be less than 4/32 of an inch on each front tire of any vehicle, not less than 2/32 inches on all other tires. Tires shall be properly inflated.

(1) Condition Red Tag:

- (a) Any tire worn less than 2/32 inch on the rear axle (4/32 on steering axle) when measured in any two adjacent major tread groves at three locations spaced evenly around the circumference of the tire at the area of greatest wear. 49 CFR 570.62 (1).
- (b) Any tire is flat or has a noticeable (e.g. can be heard or felt) leak, or has fifty (50) percent or less of the maximum inflation pressure marked on the tire sidewall.
****NOTE:** Measure tire air pressure only if there is evidence the tire is under-inflated.

b) Valve stems, wheels and safety stops.

(1) Condition Yellow Tag:

- (a) Any tire improperly mounted on valve stem safety stop.
- (b) Safety stop is missing or damaged.



- c) Recapped, re-grooved, retreaded, reinforcement repairs to front-mounted tires and tires marked "Not for Highway Use" or labeled with specific restrictions.
 - (1) **Condition Red Tag:**
 - (a) Any tire recapped, re-grooved or recut below the original grooved depth.
 - (b) Any tire marked for restricted use. (49 CFR 570.62)
 - (c) Reinforcement repair to cord body on front-mounted tires. (49 CFR 570.62)
- d) Tire size and manufacturer specifications.
 - (1) **Condition Red Tag:**
 - (a) Radial and bias type tires on the same axle. (49 CFR 570.62)
 - (b) Mixed size tires on same axle. (49 CFR 570.62)
 - (c) So mounted or inflated so that it comes in contact with any part of the vehicle or its mate in a dual set.
- e) Spare tires.
 - (1) **Condition Red Tag:**
 - (a) Type I spare inside passenger compartment.
 - (b) Type II loose spare tire inside passenger compartment.
- f) Wheels and Rims

A tire rim, wheel disc or spider shall have no visible cracks, elongated bolt holes, or indication of in-service repair by welding.

 - (1) **Condition Red Tag:**
 - (a) Any welded repairs on wheels or spokes. (49 CFR 570.63)
 - (b) Rims, spacers and or rings are bent, sprung, cracked, improperly seated, damaged or mismatched.
 - (c) No gap at split ring ends.

Cast wheels shall not be cracked or show evidence of excessive wear in the clamp area.

 - (2) **Condition Red Tag:**
 - (a) The casting is cracked or there is evidence of wear in the clamping area. (49 CFR 570.63)
- g) Disc wheels.
 - (1) **Condition Red Tag:**
 - (a) Stud holes are out of round.
 - (b) There are cracks between the hand holes and/or the stud holes in the disc.

All wheel nuts and clamps shall be in place and tight.

 - (2) **Condition Red Tag:**
 - (a) Clamps or nuts are loose, damaged or missing.
- h) Hub***
 - (1) **Condition Yellow Tag:**
 - (a) Evidence of actively leaking wheel seal.
 - (2) **Condition Red Tag:**
 - (a) Excessive wheel bearing play.

***NOTE: Refer to the applicable contaminated friction material criterion in "Brake Systems," when condition is present.



CLAMP TYPE BRAKE CHAMBER DATA

TYPE	OUTSIDE DIAMETER	BRAKE ADJUSTMENT LIMIT	FULL DEFECT LIMIT
6	4 1/2	1 1/4	1 1/2
9	5 1/4	1 3/8	1 5/8
12	5 11/16	1 3/8	1 5/8
16	6 3/8	1 3/4	2
20	6 25/32	1 3/4	2
24	7 7/32	1 3/4	2
30	8 3/32	2	2 1/4
36	9	2 1/4	2 1/2

LONG STROKE CLAMP TYPE BRAKE CHAMBER DATA

Type	Outside Diameter	Brake Adjustment Limit	Full Defect Limit
12	5 11/16	1 3/4	2
16	6 3/8	2	2 1/4
20 (2 1/2" Stroke)	6 25/32	2	2 1/4
20 (3" Stroke)	6 25/32	2 1/2	2 3/4
24 (2 1/2" Stroke)	7 7/32	2	2 1/4
24 (3" Stroke)	7 7/32	2 1/2	2 3/4
30	8 3/32	2 1/2	2 3/4



AIR BRAKE SYSTEM TEST PROCEDURE

Two people are required to do these performance/safety brake tests.

1. The vehicle must have a minimum of 90 PSI air pressure in the Brake System.
2. Turn the ignition key to the on position.
3. Make sure the YELLOW ABS LIGHT illuminates on, then goes off.
4. With the parking brake released and the engine not running, press and hold the brake pedal down for one minute. Listen for service brake air leaks and watch the air gauges. (Vehicle should not lose more than 3 psi per minute.)
5. Open the hood. While holding the brake pedal down, check the front brake adjustment.
6. When under the vehicle, confirm the pop-off valve is on the wet tank.
7. Drain the wet tank while someone is watching the air gauges. Make sure that the primary and secondary air gauges/tanks do not lose air pressure.
8. Drain the secondary air tank. At 60 PSI the low air pressure light and alarm should activate. No air loss should occur with the primary air gauge/tank.
9. Start the engine and build the air pressure to a minimum of 90PSI.
10. Drain the primary air tank while watching the air gauges. At 60 PSI the low air pressure warning light and alarm should activate. No air loss should occur with the secondary air gauge/tank.
11. Press down on the brake pedal while someone is near the rear brakes. The spring brake valve should activate applying the rear brakes.
12. Confirm that both brake chambers are working properly and the rear brakes are in adjustment.
13. Pump the brake pedal dropping the air pressure down to 20 psi-40 psi to confirm that the dash valve pops out applying the parking brake.
14. Build system air pressure to confirm that air pressure builds to 120 PSI plus or minus 5 psi and the air dryer purges properly. (Build up time from 50 psi to 90 psi must be three minutes or less).
15. With the parking brake still applied, start the engine and place the shifter into drive. Press on the accelerator pedal until engine RPMs reach 1,100. The parking brake should hold, not allowing the vehicle to move.

School Bus Exterior Mirror Adjustment

FMVSS [49 CFR 571.111 S9-S94\(a\) & S13-S13.3\(g\)](#)
& PA-187 Section [MCL 257.1823](#)

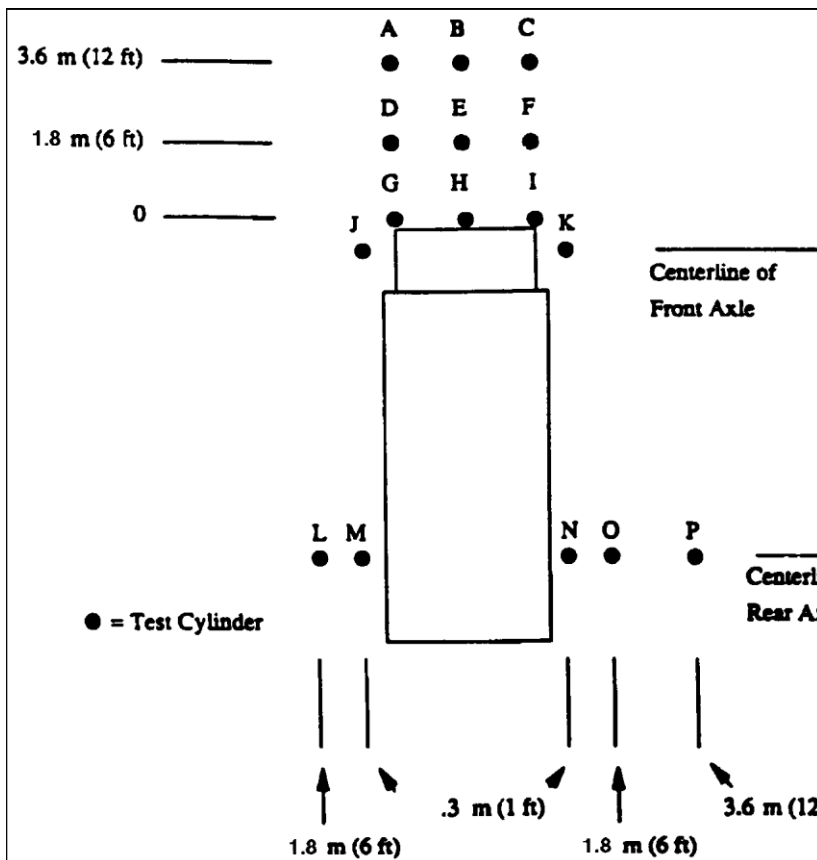
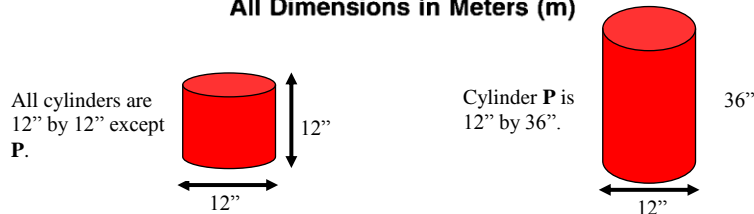

Figure 2.—Location of Test Cylinders for School Bus Field-of-View
All Dimensions in Meters (m)





The content of the School Bus Inspection Manual is a continuing project between the Michigan State Police and members of the Michigan Association for Pupil Transportation. The following individuals are to be recognized for their contributions to school bus safety.

MAPT Legislative Committee Subcommittee Members

- Insp. Randy Coplin**, MSP-CVED..... coplinr@michigan.gov
(517) 241-0479
- Lt. Steven Horwood**, MSP-CVED..... horwoods@michigan.gov
(517) 241-0545
- Sgt. Michael McLaughlin**, MSP-CVED mclaughlinm3@michigan.gov
(517) 241-0572
- VSI Dale Womble**, MSP-CVED..... wombled@michigan.gov
(517) 322-5578
- Gary Bubar**, Executive Director, MAPT..... gbubar@mapt.org
(517) 886-0881
- H. “Mac” Dashney**, PTO&MI..... h.dashney@comcast.net
(517) 420-2856
- Dave Davis**, Service Mgr, Midwest Transit Eqipt. of MI dave.davis@midwesttransit.com
(269) 425-0690
- Kevin Doty**, Transportation Supervisor, Mason Public Schools kdoty@mason.k12.mi.us
(517) 676-6496
- Douglas Francis**, Assoc. Trans. Director/Head Mechanic, Gaylord Community Schools .. francisd@gaylord.k12.mi.us
(989) 705-3021
- Randy Hood**, Head Mechanic, Van Buren ISD rhood@vbisd.org
(269) 674-8001
- John Kurkowski**, Auxiliary Services Director, Marquette Area Public Schools..... jkurkowski@mapsnet.org
(906) 225-5773
- Scott Pellerito**, Director Fleet Services, Dean Transportation..... scottp@deantrans.com
(517) 319-8355
- Lori Richardson**, Program Director, Transportation Services, Oakland Schools lori.richardson@oakland.k12.mi.us
(248) 209-2224
- Paul Wegmeyer**, Transportation Supervisor, Holt Public Schools
Chair, MAPT Legislative Committee..... pwegmeyer@hpsk12.net
(517) 699-0248