



STATE OF MICHIGAN ENTERPRISE PROCUREMENT

Department of Technology, Management, and Budget
320 S. Walnut Street 2nd Floor Lansing, MI 48933
P.O. BOX 30026 LANSING, MICHIGAN 48909

CONTRACT CHANGE NOTICE

Change Notice Number 5
to
Contract Number MA20000000373

CONTRACTOR	CORRECTIONAL TECHNOLOGIES, INC.
	7530 Plaza Court
	Willowbrook IL 60527
	Steve Csuk
	630-445-0811
	steve@cortechusa.com
	CV0017523

STATE	Program Manager	Various	Various
STATE	Contract Administrator	Susan Watt-Smith	DTMB
		517-230-0535	
		wattsmiths@michigan.gov	

CONTRACT SUMMARY			
Anti-Ligature Furnishing Services - Statewide			
INITIAL EFFECTIVE DATE	INITIAL EXPIRATION DATE	INITIAL AVAILABLE OPTIONS	EXPIRATION DATE BEFORE
February 1, 2020	January 31, 2025	5 - 12 Months	January 31, 2025
PAYMENT TERMS		DELIVERY TIMEFRAME	
1NET10; 1½ NET15; Net 45		N/A	
ALTERNATE PAYMENT OPTIONS		EXTENDED PURCHASING	
<input type="checkbox"/> P-Card <input type="checkbox"/> Direct Voucher (PRC) <input type="checkbox"/> Other		<input checked="" type="checkbox"/> Yes <input type="checkbox"/> No	
MINIMUM DELIVERY REQUIREMENTS			
N/A			
DESCRIPTION OF CHANGE NOTICE			
OPTION	LENGTH OF OPTION	EXTENSION	REVISED EXP. DATE
<input checked="" type="checkbox"/>	12 Months	<input type="checkbox"/>	January 31, 2026
CURRENT VALUE	VALUE OF CHANGE NOTICE	ESTIMATED AGGREGATE CONTRACT VALUE	
\$2,245,000.00	\$0.00	\$2,245,000.00	
DESCRIPTION			
<p>Effective February 1, 2025, the first option year available on this contract is hereby exercised. The revised contract expiration date is January 31, 2026. Additionally, the attached Schedule B - Pricing hereby replaces and supersedes any and all previous versions.</p> <p>All other terms, conditions, specifications and pricing remain the same. Per contractor and agency agreement, and DTMB Central Procurement approval.</p>			

**Program Managers
for
Multi-Agency and Statewide Contracts**

AGENCY	NAME	PHONE	EMAIL
MDOC	Eames E. Groenleer	517-780-6076	GroenleerE@michigan.gov
MDOC	George B. Sevarns	906-293-0005	SevarnsG@michigan.gov
MDHHS	Lauri Bonnell	517-335-0175	BonnellL@michigan.gov

STATE OF MICHIGAN

Change Notice 5

Contract No. 200000000373

Statewide – Anti-Ligature Furnishing Services

SCHEDULE B PRICING

1. Price proposals must include all costs, including but not limited to, any one-time or set-up charges, fee, and potential costs that Contractor may charge the State (e.g. shipping and handling, per piece pricing and palletizing).
2. Quick payment terms: 1% discount off invoice if paid within 10 days after receipt of invoice.
Quick payment terms: 1½% discount off invoice if paid within 15 days after receipt of invoice.
3. Quantity/Volume terms:
 - Quantity discount 5% off orders greater than \$50,000.00
 - Year-to-Date Total Quantity discount: An additional 5% discount will be applied on year-to- date orders exceed \$100,000.00, for the remained of the calendar year, to be rest annually.
 - Freight included Pricing for items listed in Schedule B – The contractor will re-calculate freight to include and exclude freight as a separate line item when freight is less than the Current List Pricing with Freight Included Pricing. The Contractor with the State on an order-by-order basis to determine best pricing for freight.

(Updated Pricing Tables on following pages)

Change Notice 2, Contract No. 200000000373

Correctional Technologies, Inc.

2025 Price List

FURNITURE, SEATING, and MATTRESSES

DESCRIPTION	PART NUMBER	2025 LIST PRICE EACH	2025 SOM PRICE EACH (Delivered)	2025 QUANTITY PER FULL SKID	2025 SOM PRICE EACH PER SKID (Delivered)	2025 SOM TOTAL PRICE PER SKID (Delivered)
EZ Bunk(TM) Sleep Surface Gray	7501	\$ 583.80	\$ 350.28	20	332.77	6,655.32
EZ Bunk(TM) Sleep Surface Blue	7502	\$ 583.80	\$ 350.28	20	332.77	6,655.32
Barracuda Box 1.5 cu ft	3825P	\$ 86.00	\$ 47.60	32	45.02	1,440.64
Barracuda Box 2.0 cu ft	7268P	\$ 92.00	\$ 50.20	32	47.44	1,518.08
Barracuda Box Lid universal	9689	\$ 52.00	\$ 30.20	32	28.64	916.48
Barracuda Box 3.0 cu ft	8568P	\$ 132.00	\$ 79.20	18	75.24	1,354.32
Barracuda Box Lid for 3.0 cu ft	8289P	\$ 90.00	\$ 54.00	18	51.30	923.40
Masterbox 1.5	3825M	\$ 116.00	\$ 69.60	32	66.12	2,115.84
Masterbox 2.0	7268M	\$ 122.00	\$ 73.20	32	69.54	2,225.28
Masterbox 1.5/2.0 Lid	9689M	\$ 62.00	\$ 37.20	32	35.34	1,130.88
Masterbox 3.0	8568M	\$ 162.00	\$ 97.20	18	92.34	1,662.12
Masterbox 3.0 Lid	8289M	\$ 100.00	\$ 60.00	18	57.00	1,026.00
Stackable Chair Slate Blue	86484SB	\$ 105.00	\$ 63.00	50	59.85	2,992.50
Stackable Chair Blue Gray	86484BG	\$ 105.00	\$ 63.00	50	59.85	2,992.50
Stackable Chair Buff	86484B	\$ 105.00	\$ 63.00	50	59.85	2,992.50
Stackable Chair Plum	86484P	\$ 105.00	\$ 63.00	50	59.85	2,992.50
Stackable Chair Fog Gray	86484FG	\$ 105.00	\$ 63.00	50	59.85	2,992.50
Stackable Chair Black	86484BK	\$ 105.00	\$ 63.00	50	59.85	2,992.50
Stackable ChairTeal	86484T	\$ 105.00	\$ 63.00	50	59.85	2,992.50
Stackable Chair Green	86484GN	\$ 105.00	\$ 63.00	50	59.85	2,992.50
Stackable Chair Brown	86484BN	\$ 105.00	\$ 63.00	50	59.85	2,992.50
Chair Dolly	DY9000	\$ 336.00	\$ 201.60	5	191.52	957.60
Structured Seating 1 Seat No Arms	10(color)	\$ 1,627.50	\$ 976.50	12	927.68	11,132.10
Structured Seating 2 Seats No Arms	20(color)	\$ 2,520.00	\$ 1,512.00	3	1,436.40	4,309.20
Structured Seating 3 Seats No Arms	30(color)	\$ 3,255.00	\$ 1,953.00	3	1,855.35	5,566.05
Structured Seating 4 Seats No Arms	40(color)	\$ 4,410.00	\$ 2,646.00	3	2,513.70	7,541.10
Structured Seating 2 Seats With Arms	22(color)	\$ 2,730.00	\$ 1,638.00	3	1,556.10	4,668.30

Change Notice 2, Contract No. 200000000373

Correctional Technologies, Inc.

2025 Price List

FURNITURE, SEATING, and MATTRESSES

DESCRIPTION	PART NUMBER	2025 LIST PRICE EACH	2025 SOM PRICE EACH (Delivered)	2025 QUANTITY PER FULL SKID	2025 SOM PRICE EACH PER SKID (Delivered)	2025 SOM TOTAL PRICE PER SKID (Delivered)
Structured Seating 3 Seats With Arms	32(color)	\$ 3,465.00	\$ 2,079.00	3	1,975.05	5,925.15
Structured Seating 4 Seats With Arms	42(color)	\$ 4,672.50	\$ 2,803.50	3	2,663.33	7,989.98
Structured Seating 2 Seats Arms/Dividers	23(color)	\$ 2,940.00	\$ 1,764.00	3	1,675.80	5,027.40
Structured Seating 3 Seats Arms/Dividers	34(color)	\$ 3,885.00	\$ 2,331.00	3	2,214.45	6,643.35
Structured Seating 4 Seats Arms/Dividers	45(color)	\$ 5,040.00	\$ 3,024.00	3	2,872.80	8,618.40
Acrylic Mirror 11x15	VM1115	\$ 140.00	\$ 84.00	10	79.80	798.00
Acrylic Mirror 15x20	VM1520	\$ 184.00	\$ 110.40	10	104.88	1,048.80
Acrylic Mirror 18x24	VM1824	\$ 246.00	\$ 147.60	10	140.22	1,402.20

Change Notice 2, Contract No. 200000000373

Correctional Technologies, Inc.

2025 Price List

FOR ENDURANCE LINES BELOW, ADD COLOR CODE TO THE END OF THE PART NUMBER	Aqua (AQ)	Blue Gray (BG)	Burgundy (BY)	Green (GN)	Midnight Blue (MB)	Slate Blue (SB)
	Black (BK)	Brown (BN)	Gray (GY)	Indigo (IG)	Sand (SD)	Stone Gray (SG)
DESCRIPTION	PART NUMBER	2025 LIST PRICE EACH	2025 SOM PRICE EACH (Delivered)	2025 QUANTITY PER FULL SKID	2025 SOM PRICE EACH PER SKID (Delivered)	2025 SOM TOTAL PRICE PER SKID (Delivered)
Sabre Chair-floor mount, gangable	96484(color)	\$ 672.00	\$ 403.20	6	383.04	2,298.24
Sabre Chair- floor mount, gangable with access door	96484(color)S	\$ 808.50	\$ 485.10	6	460.85	2,765.07
Sentinel Armless Chair-floor mount, gangable	116484(color)	\$ 530.00	\$ 318.00	6	302.10	1,812.60
Sentinel Armless Chair- floor mount, gangable with access door	116484(color)S	\$ 630.00	\$ 378.00	6	359.10	2,154.60
Sentinel Arm Chair-floor mount, gangable	106484(color)	\$ 577.50	\$ 346.50	6	329.18	1,975.05
Sentinel Arm Chair- floor mount, gangable with access door	106484(color)S	\$ 682.50	\$ 409.50	6	389.03	2,334.15
Sync Chair 2- floor mount, gangable	270(color)	\$ 577.50	\$ 346.50	6	329.18	1,975.05
Sync Chair 2- floor mount, gangable with access door	270(color)S	\$ 682.50	\$ 409.50	6	389.03	2,334.15
Sync Chair Slim- floor mount, gangable	272(color)	\$ 567.00	\$ 340.20	6	323.19	1,939.14
Sync Chair Slim- floor mount, gangable with access door	272(color)S	\$ 672.00	\$ 403.20	6	383.04	2,298.24
Sync Wedge- floor mount, gangable	274(color)	\$ 546.00	\$ 327.60	4	311.22	1,244.88
Sync Wedge- floor mount, gangable with access door	274(color)S	\$ 672.00	\$ 403.20	4	383.04	1,532.16
Sync Cube- floor mount	276(color)	\$ 535.50	\$ 321.30	7	305.24	2,136.65
Sync Cube- floor mount with access door	276(color)S	\$ 651.00	\$ 390.60	7	371.07	2,597.49
Endurance Crew Chair-Armless	6484(color)	\$ 497.70	\$ 298.62	6	283.69	1,702.13
Endurance Crew Chair-Armless, w/ Access Door	6484(color)S	\$ 497.70	\$ 298.62	6	283.69	1,702.13
Endurance Crew Chair-Armless, Includes Bolt Down Kit	6484(color)KT	\$ 714.00	\$ 428.40	6	406.98	2,441.88
Endurance Crew Chair-w/ Arms	7484(color)	\$ 567.00	\$ 340.20	6	323.19	1,939.14
Endurance Crew Chair-w/ Arms, W/ Access Door	7484(color)S	\$ 700.00	\$ 420.00	6	399.00	2,394.00
Endurance Crew Chair-w/ Arms, Includes Bolt Down Kit	7484(color)KT	\$ 793.80	\$ 476.28	6	452.47	2,714.80
Radial Rocker	146484 (color)	\$ 928.20	\$ 556.92	2	529.07	1,058.15
Radial Rocker Black with access door	146484(color)S	\$ 1,050.00	\$ 630.00	2	598.50	1,197.00
Endurance Bench	136484(color)	\$ 1,113.00	\$ 667.80	10	634.41	6,344.10
Endurance Cube	126484(color)	\$ 535.50	\$ 321.30	18	305.24	5,494.23

Change Notice 2, Contract No. 200000000373

Correctional Technologies, Inc.

2025 Price List

FOR ENDURANCE LINES BELOW, ADD COLOR CODE TO THE END OF THE PART NUMBER	Aqua (AQ)	Blue Gray (BG)	Burgundy (BY)	Green (GN)	Midnight Blue (MB)	Slate Blue (SB)
	Black (BK)	Brown (BN)	Gray (GY)	Indigo (IG)	Sand (SD)	Stone Gray (SG)
DESCRIPTION	PART NUMBER	2025 LIST PRICE EACH	2025 SOM PRICE EACH (Delivered)	2025 QUANTITY PER FULL SKID	2025 SOM PRICE EACH PER SKID (Delivered)	2025 SOM TOTAL PRICE PER SKID (Delivered)
Endurance Cube Black with Access Door	126484(color)S	\$ 630.00	\$ 378.00	18	359.10	6,463.80
Trash Can 10 quart Flame Retardant (6 pack)	710(color)CS	\$ 352.80	\$ 211.68	38	201.10	7,641.65
Trash Can 14 quart Flame Retardant (6 pack)	714(color)CS	\$ 361.20	\$ 216.72	38	205.88	7,823.59
Solstice Bed	100(color)	\$ 2,070.00	\$ 1,242.00	4	1,179.90	4,719.60
Solstice Bed- 3 Doors	100(color)S3	\$ 2,560.00	\$ 1,536.00	4	1,459.20	5,836.80
Solstice Safetyguard Bed	101(color)	\$ 2,500.00	\$ 1,500.00	2	1,425.00	2,850.00
Solstice Safetyguard Bed- 3 Doors	101(color)S3	\$ 2,950.00	\$ 1,770.00	2	1,681.50	3,363.00
Endurance Bed 0.0	7500(color)	\$ 2,100.00	\$ 1,260.00	6	1,197.00	7,182.00
Endurance Bed 1.0	7601(color)	\$ 2,205.00	\$ 1,323.00	4	1,256.85	5,027.40
Endurance Bed 1.5	7615(color)	\$ 2,400.00	\$ 1,440.00	3	1,368.00	4,104.00
Endurance Bed 2.0	7801(color)	\$ 2,520.00	\$ 1,512.00	3	1,436.40	4,309.20
Endurance Bed 2.1 with side storage compartments	7802(color)	\$ 3,465.00	\$ 2,079.00	3	1,975.05	5,925.15
Endurance Bed 2.2 no storage compartments	7803(color)	\$ 2,415.00	\$ 1,449.00	3	1,376.55	4,129.65
Endurance Wall Bunk	7701(color)	\$ 2,625.00	\$ 1,575.00	5	1,496.25	7,481.25
Endurance Wall Bunk Safety Rail	7702(color)	\$ 510.00	\$ 306.00	40	290.70	11,628.00
Endurance Wall Bunk Small Safety Rail	7703(color)	\$ 420.00	\$ 252.00	40	239.40	9,576.00
Endurance Wall Bunk Ladder	7704(color)	\$ 960.00	\$ 576.00	10	547.20	5,472.00
Restraint Rings for Endurance Bed and Endurance 2.0 Bed	302003	\$ 48.00	\$ 28.80	NA	NA	
Bed Ballast Door Kit	7500(color)KT	\$ 220.00	\$ 132.00	NA	NA	
Correctional Mattress, 25x75 Fiber Core, Standard Cover w/ Double Sided Pillow, Blue	C452575P	\$ 320.00	\$ 189.99	NA	NA	
Correctional Mattress, 30x75 Fiber Core, Standard Cover w/ Double Sided Pillow, Blue	C453075P	\$ 390.00	\$ 234.00	NA	NA	

Change Notice 2, Contract No. 200000000373

Correctional Technologies, Inc.

2025 Price List

FOR ENDURANCE LINES BELOW, ADD COLOR CODE TO THE END OF THE PART NUMBER	Aqua (AQ)	Blue Gray (BG)	Burgundy (BY)	Green (GN)	Midnight Blue (MB)	Slate Blue (SB)
	Black (BK)	Brown (BN)	Gray (GY)	Indigo (IG)	Sand (SD)	Stone Gray (SG)
DESCRIPTION	PART NUMBER	2025 LIST PRICE EACH	2025 SOM PRICE EACH (Delivered)	2025 QUANTITY PER FULL SKID	2025 SOM PRICE EACH PER SKID (Delivered)	2025 SOM TOTAL PRICE PER SKID (Delivered)
Correctional Mattress, 35x75 Fiber Core, Standard Cover w/ Double Sided Pillow, Blue	C453575P	\$ 395.00	\$ 237.00	NA	NA	
Correctional Mattress, 25x75 Fiber Core, Seg Max cover w/ Double Sided Pillow, Black	SEG452575P	\$ 680.00	\$ 408.00	NA	NA	
Correctional Mattress, 30x75 Fiber Core, Seg Max Cover w/ Double Sided Pillow, Black	SEG453075P	\$ 700.00	\$ 420.00	NA	NA	
Correctional Mattress, 35x75 Fiber Core, Seg Max Cover w/ Double Sided Pillow, Black	SEG453575P	\$ 720.00	\$ 432.00	NA	NA	
Correctional Mattress, 36x80 Foam Core, Standard Cover, Gray	G603680	\$ 700.00	\$ 420.00	NA	NA	
Correctional Mattress, 36x75 Foam Core, Standard Cover, Gray	G603675	\$ 700.00	\$ 420.00	NA	NA	
Correctional Mattress, 36x80 Foam Core, Seg Max Cover, Black	SEG603680	\$ 940.00	\$ 564.00	NA	NA	
Correctional Mattress, 36x75 Foam Core, Seg Max Cover, Black	SEG603675	\$ 940.00	\$ 564.00	NA	NA	
Endurance Bed Riser for 2.0 Bed	7606(color)	\$ 1,648.50	\$ 989.10	8	939.65	7,517.16
Endurance NightStand	7602(color)	\$ 504.00	\$ 302.40	16	287.28	4,596.48
Endurance Laminate Nightstand	7609(color)	\$ 892.50	\$ 535.50	16	508.73	8,139.60
Endurance Desk, Laminate Top, Wall Mount	7603(color)	\$ 1,323.00	\$ 793.80	5	754.11	3,770.55
Endurance Desk, All plastic, Wall Mount	7605(color)	\$ 1,239.00	\$ 743.40	5	706.23	3,531.15
Endurance Desk, All plastic, Standing/floor Mount	7607(color)	\$ 1,249.50	\$ 749.70	5	712.22	3,561.08
Endurance Desk, All plastic, Laminate Top, Standing/floor Mount	7608(color)	\$ 1,732.50	\$ 1,039.50	5	987.53	4,937.63
Endurance ADA Desk, Laminate Top, Wall Mount (5 or more)	7610(color)	\$ 1,218.00	\$ 730.80	5	694.26	3,471.30
Endurance ADA Desk, Laminate Top, Wall Mount (Single)	7610(color)	\$ 1,890.00	\$ 1,134.00	5	1,077.30	5,386.50
Endurance ADA Desk, All plastic, Floor Mount	7611(color)	\$ 1,228.50	\$ 737.10	5	700.25	3,501.23
Hook Max Plus- pack of 5	HMP(color)	\$ 220.00	\$ 132.00	10	125.40	1,254.00
Hook Max- pack of 5	HM(color)	\$ 220.00	\$ 132.00	10	125.40	1,254.00

Change Notice 2, Contract No. 200000000373

Correctional Technologies, Inc.

2025 Price List

FOR ENDURANCE LINES BELOW, ADD COLOR CODE TO THE END OF THE PART NUMBER	Aqua (AQ)	Blue Gray (BG)	Burgundy (BY)	Green (GN)	Midnight Blue (MB)	Slate Blue (SB)
	Black (BK)	Brown (BN)	Gray (GY)	Indigo (IG)	Sand (SD)	Stone Gray (SG)
DESCRIPTION	PART NUMBER	2025 LIST PRICE EACH	2025 SOM PRICE EACH (Delivered)	2025 QUANTITY PER FULL SKID	2025 SOM PRICE EACH PER SKID (Delivered)	2025 SOM TOTAL PRICE PER SKID (Delivered)
Standard Hook- pack of 5	JT-(Color)	\$ 160.00	\$ 96.00	10	91.20	912.00
Endurance Wall 2 shelf	7614(color)	\$ 535.50	\$ 321.30	12	305.24	3,662.82
Endurance 4 shelf	7111(color)	\$ 1,075.20	\$ 645.12	8	612.86	4,902.91
Endurance All Purpose Shelf	7600(color)	\$ 199.50	\$ 119.70	144	113.72	16,374.96
Endurance All Purpose Shelf 2.0	8600(color)	\$ 220.50	\$ 132.30	48	125.69	6,032.88
Endurance Chest	7201(color)	\$ 966.00	\$ 579.60	5	550.62	2,753.10
Endurance Stool	7901(color)	\$ 262.50	\$ 157.50	20	149.63	2,992.50
Endurance Locker w/ Door	7300(color)	\$ 2,541.00	\$ 1,524.60	3	1,448.37	4,345.11
Endurance Locker NO Door	7200(color)	\$ 2,100.00	\$ 1,260.00	3	1,197.00	3,591.00
Endurance Wedge Table	484(color)	\$ 434.70	\$ 260.82	16	247.78	3,964.46
Endurance Wedge Table with Access Door	484(color)S	\$ 575.40	\$ 345.24	16	327.98	5,247.65
Endurance Wedge Table- Bolt Down Kit ONLY	484KIT	\$ 105.00	\$ 63.00	NA	59.85	
Endurance Round Base Table, 42" Round Top, W/Access Door	668(color)S	\$ 1,438.50	\$ 863.10	8	819.95	6,559.56
Endurance Round Base Table, 42" Round Top, Game Top	668(color)GTS	\$ 1,680.00	\$ 1,008.00	8	957.60	7,660.80
Endurance Cascade Base Table, 42" Round Top, W/ Access Door	670(color)S	\$ 1,440.00	\$ 864.00	8	820.80	6,566.40
Endurance Cascade Base Table, 42" Round Top, Game Top, W/ Access Door	670(color)GTS	\$ 1,680.00	\$ 1,008.00	8	957.60	7,660.80
Endurance Table 42" Round X-Base Flame Retardant	66749(color)	\$ 1,522.50	\$ 913.50	4	867.83	3,471.30
Endurance Table 42" Round X-Base Flame Retardant Game Top	66749(color)GT	\$ 1,732.50	\$ 1,039.50	4	987.53	3,950.10
Endurance Table 42" Square X-Base Flame Retardant	66750(color)	\$ 1,575.00	\$ 945.00	4	897.75	3,591.00
Endurance Table 42" Square X-Base Flame Retardant Game Top	66750(color)GT	\$ 1,764.00	\$ 1,058.40	4	1,005.48	4,021.92
Endurance Table 48" Round X-Base Flame Retardant	66751(color)	\$ 1,795.50	\$ 1,077.30	6	1,023.44	6,140.61
Endurance Table 48" Round X-Base Flame Retardant Game Top	66751(color)GT	\$ 1,974.00	\$ 1,184.40	6	1,125.18	6,751.08
Anchor Table, 6 Person, 30"x72" Plain Top*Choose Seat Color	3072ADPB	\$ 3,550.00	\$ 2,130.00	2	2,023.50	4,047.00

Change Notice 2, Contract No. 200000000373

Correctional Technologies, Inc.

2025 Price List

FOR ENDURANCE LINES BELOW, ADD COLOR CODE TO THE END OF THE PART NUMBER	Aqua (AQ)	Blue Gray (BG)	Burgundy (BY)	Green (GN)	Midnight Blue (MB)	Slate Blue (SB)
	Black (BK)	Brown (BN)	Gray (GY)	Indigo (IG)	Sand (SD)	Stone Gray (SG)
DESCRIPTION	PART NUMBER	2025 LIST PRICE EACH	2025 SOM PRICE EACH (Delivered)	2025 QUANTITY PER FULL SKID	2025 SOM PRICE EACH PER SKID (Delivered)	2025 SOM TOTAL PRICE PER SKID (Delivered)
Anchor Table, 8 Person, 30"x96" Plain Top*Choose Seat Color	3096ADPB	\$ 4,800.00	\$ 2,880.00	2	2,736.00	5,472.00
Anchor Table, 4 Person 42" Round Plain Top *Choose Seat Color	42RDAB	\$ 2,700.00	\$ 1,620.00	4	1,539.00	6,156.00
Anchor Table, 4 Person, 42" Square Plain Top *Choose Seat Color	42SDAB	\$ 2,400.00	\$ 1,440.00	4	1,368.00	5,472.00
Anchor Table, 6 person, 48" Round Plain Top *Choose Seat Color	48R6DAB	\$ 3,600.00	\$ 2,160.00	4	2,052.00	8,208.00
Table- 36"x36" Square Dura-Edge Plain-Top Steel-Legs	36SDPS	\$ 1,920.00	\$ 1,152.00	4	1,094.40	4,377.60
Table- 36"x36" Square Dura-Edge Game-Top Steel-Legs	36SDGS	\$ 2,110.00	\$ 1,266.00	4	1,202.70	4,810.80
Table- 42" Round Dura-Edge Plain-Top Steel-Legs	42RDPS	\$ 2,270.00	\$ 1,362.00	4	1,293.90	5,175.60
Table- 42"x42" Square Dura-Edge Plain-Top Steel-Legs	42SDPS	\$ 2,060.00	\$ 1,236.00	4	1,174.20	4,696.80
Table- 42"x42" Square Dura-Edge Game-Top Steel-Legs	42SDGS	\$ 2,270.00	\$ 1,362.00	4	1,293.90	5,175.60
Table- 48" Round Dura-Edge Plain-Top Steel-Legs	48RDPS	\$ 2,380.00	\$ 1,428.00	4	1,356.60	5,426.40
Table- 48" Round Dura-Edge Game-Top Steel-Legs	48RDGS	\$ 2,580.00	\$ 1,548.00	4	1,470.60	5,882.40
Table- 30"x72" Dura Edge Plain-Top Steel Legs	3072DPS	\$ 2,270.00	\$ 1,362.00	2	1,293.90	2,587.80
Table- 36"x36" Square Dura-Edge Plain-Top Xbase-Legs	36SDPX	\$ 1,365.00	\$ 819.00	2	778.05	1,556.10
Table- 36"x36" Square Dura-Edge Game-Top Xbase-Legs	36SDGX	\$ 1,575.00	\$ 945.00	2	897.75	1,795.50
Table- 42" Round Dura-Edge Plain-Top Xbase-Legs	42RDPX	\$ 1,680.00	\$ 1,008.00	2	957.60	1,915.20
Table- 42"x42" Square Dura-Edge Plain-Top Xbase-Legs	42SDPX	\$ 1,470.00	\$ 882.00	2	837.90	1,675.80
Table- 42"x42" Square Dura-Edge Game-Top Xbase-Legs	42SDGX	\$ 1,575.00	\$ 945.00	2	897.75	1,795.50
Table- 48" Round Dura-Edge Plain-Top Xbase-Legs	48RDPX	\$ 1,785.00	\$ 1,071.00	2	1,017.45	2,034.90
Table- 48" Round Dura-Edge Game-Top Xbase-Legs	48RDGX	\$ 1,942.50	\$ 1,165.50	2	1,107.23	2,214.45
Game Top and ADA Available Upon Request						

Change Notice 2, Contract No. 200000000373

Correctional Technologies, Inc.

2025 Price List

FOOD SERVICE and FACILITY MAINTENANCE

DESCRIPTION	PART NUMBER	2025 LIST PRICE EACH	2025 SOM PRICE EACH (Delivered)	2025 QUANTITY PER FULL SKID	2025 SOM PRICE EACH PER SKID (Delivered)	2025 SOM TOTAL PRICE PER SKID (Delivered)
Chuckwagon Plastic Base	C1717	\$ 7,980.00	\$ 4,788.00	NA	NA	NA
Chuckwagon Plastic Base with locking hasp doors	C1717LH	\$ 8,400.00	\$ 5,040.00	NA	NA	NA
Chuckwagon Stainless Steel Base	C1720	\$ 12,600.00	\$ 7,560.00	NA	NA	NA
Chuckwagon Stainless Steel Base with locking hasp doors	C1720LH	\$ 12,705.00	\$ 7,623.00	NA	NA	NA
Chuckwagon Stainless Steel Base with Tow & Hitch	C1720TH	\$ 16,380.00	\$ 9,828.00	NA	NA	NA
Chuckwagon Stainless Steel Base with Tow & Hitch & Locking Doors	C1720LHTH	\$ 16,800.00	\$ 10,080.00	NA	NA	NA
Chuckwagon Jr.	C1716	\$ 5,460.00	\$ 3,276.00	NA	NA	NA
Chuckwagon Jr. with Locking hasp	C1716LH	\$ 6,090.00	\$ 3,654.00	NA	NA	NA
Tray Master Food Delivery Cart	C1719	\$ 5,250.00	\$ 3,150.00	NA	NA	NA
Rock Tray Chocolate - Case of 10	2000C	\$ 315.00	\$ 189.00	30	179.55	5,386.50
Rock Tray Orange - Case of 10	2000O	\$ 315.00	\$ 189.00	30	179.55	5,386.50
Rock Tray Terra Cotta - Case of 10	2000TC	\$ 315.00	\$ 189.00	30	179.55	5,386.50
Rock Tray Dark Gray - Case of 10	2000DG	\$ 315.00	\$ 189.00	30	179.55	5,386.50
Rock Tray Lid Chocolate - Case of 10	2000CL	\$ 193.20	\$ 115.92	30	110.12	3,303.72
Rock Tray Lid Orange - Case of 10	2000OL	\$ 193.20	\$ 115.92	30	110.12	3,303.72
Rock Tray Lid Terra Cotta - Case of 10	2000TCL	\$ 193.20	\$ 115.92	30	110.12	3,303.72
Rock Tray Lid Dark Gray - Case of 10	2000DGL	\$ 193.20	\$ 115.92	30	110.12	3,303.72
XTray Chocolate - Case of 10	3000C	\$ 346.50	\$ 207.90	30	197.51	5,925.15
XTray Orange - Case of 10	3000O	\$ 346.50	\$ 207.90	30	197.51	5,925.15
XTray Terra Cotta - Case of 10	3000TC	\$ 346.50	\$ 207.90	30	197.51	5,925.15
XTray Dark Gray - Case of 10	3000DG	\$ 346.50	\$ 207.90	30	197.51	5,925.15
Xtray Lid Chocolate - Case of 10	3000CL	\$ 210.00	\$ 126.00	30	119.70	3,591.00
Xtray Lid Orange - Case of 10	3000OL	\$ 210.00	\$ 126.00	30	119.70	3,591.00
Xtray Lid Terra Cotta - Case of 10	3000TCL	\$ 210.00	\$ 126.00	30	119.70	3,591.00
Xtray Lid Dark Gray - Case of 10	3000DGL	\$ 210.00	\$ 126.00	30	119.70	3,591.00
Rock Tray 2.0 Chocolate - Case of 10	2500C	\$ 357.00	\$ 214.20	30	203.49	6,104.70
Rock Tray 2.0 Orange - Case of 10	2500O	\$ 357.00	\$ 214.20	30	203.49	6,104.70

Change Notice 2, Contract No. 200000000373

Correctional Technologies, Inc.

2025 Price List

FOOD SERVICE and FACILITY MAINTENANCE

DESCRIPTION	PART NUMBER	2025 LIST PRICE EACH	2025 SOM PRICE EACH (Delivered)	2025 QUANTITY PER FULL SKID	2025 SOM PRICE EACH PER SKID (Delivered)	2025 SOM TOTAL PRICE PER SKID (Delivered)
Rock Tray 2.0 Terra Cotta - Case of 10	2500TC	\$ 357.00	\$ 214.20	30	203.49	6,104.70
Rock Tray 2.0 Dark Gray - Case of 10	2500DG	\$ 357.00	\$ 214.20	30	203.49	6,104.70
Rock Flexible Tray Chocolate - Case of 10	2000CF	\$ 514.50	\$ 308.70	30	293.27	8,797.95
Rock Flexible Tray Orange - Case of 10	2000OF	\$ 514.50	\$ 308.70	30	293.27	8,797.95
Rock Flexible Tray Terra Cotta - Case of 10	2000TCF	\$ 514.50	\$ 308.70	30	293.27	8,797.95
Rock Flexible Tray Dark Gray - Case of 10	2000DGF	\$ 514.50	\$ 308.70	30	293.27	8,797.95
Bev Max 5 Gallon Beverage Dispenser Brown	BMX5BN	\$ 441.00	\$ 264.60	16	251.37	4,021.92
Bev Max 5 Gallon Beverage Dispenser Gray	BMX5GY	\$ 441.00	\$ 264.60	16	251.37	4,021.92
Bev Max 5 Gallon Beverage Dispenser Black	BMX5BK	\$ 441.00	\$ 264.60	16	251.37	4,021.92
Bev Max 5 Gallon Beverage Dispenser Granite	BMX5GT	\$ 441.00	\$ 264.60	16	251.37	4,021.92
Bev Max 5 Gallon Beverage Dispenser Orange	BMX5OR	\$ 441.00	\$ 264.60	16	251.37	4,021.92
Universal Trash Can Dolly 20 gal - 30 gal	DCC	\$ 252.00	\$ 151.20	25	143.64	3,591.00
Universal Trash Can Dolly 35 gal - 55 gal	DCCL	\$ 252.00	\$ 151.20	25	143.64	3,591.00
Food Grade Receptacle w/lid 20 gal Green	20720G	\$ 283.50	\$ 170.10	20	161.60	3,231.90
Food Grade Receptacle w/lid 22 gal Green	22720G	\$ 283.50	\$ 170.10	20	161.60	3,231.90
Food Grade Receptacle w/lid 25 gal Green	25720G	\$ 283.50	\$ 170.10	20	161.60	3,231.90
Food Grade Receptacle w/lid 30 gal Green	30720G	\$ 283.50	\$ 170.10	20	161.60	3,231.90
Food Grade Receptacle w/lid 35 gal Green	35720G	\$ 336.00	\$ 201.60	10	191.52	1,915.20
Food Grade Receptacle w/lid 40 gal Green	40720G	\$ 336.00	\$ 201.60	10	191.52	1,915.20
Food Grade Receptacle w/lid 45 gal Green	45720G	\$ 336.00	\$ 201.60	10	191.52	1,915.20
Food Grade Receptacle w/lid 50 gal Green	50720G	\$ 336.00	\$ 201.60	10	191.52	1,915.20
Food Grade Receptacle w/lid 55 gal Green	55720G	\$ 336.00	\$ 201.60	10	191.52	1,915.20
Food Grade Receptacle w/lid 20 gal Blue	20620B	\$ 283.50	\$ 170.10	20	161.60	3,231.90
Food Grade Receptacle w/lid 22 gal Blue	22620B	\$ 283.50	\$ 170.10	20	161.60	3,231.90
Food Grade Receptacle w/lid 25 gal Blue	25620B	\$ 283.50	\$ 170.10	20	161.60	3,231.90
Food Grade Receptacle w/lid 30 gal Blue	30620B	\$ 283.50	\$ 170.10	20	161.60	3,231.90
Food Grade Receptacle w/lid 35 gal Blue	35620B	\$ 336.00	\$ 201.60	10	191.52	1,915.20

Change Notice 2, Contract No. 200000000373

Correctional Technologies, Inc.

2025 Price List

FOOD SERVICE and FACILITY MAINTENANCE

DESCRIPTION	PART NUMBER	2025 LIST PRICE EACH	2025 SOM PRICE EACH (Delivered)	2025 QUANTITY PER FULL SKID	2025 SOM PRICE EACH PER SKID (Delivered)	2025 SOM TOTAL PRICE PER SKID (Delivered)
Food Grade Receptacle w/lid 40 gal Blue	40620B	\$ 336.00	\$ 201.60	10	191.52	1,915.20
Food Grade Receptacle w/lid 45 gal Blue	45620B	\$ 336.00	\$ 201.60	10	191.52	1,915.20
Food Grade Receptacle w/lid 50 gal Blue	50620B	\$ 336.00	\$ 201.60	10	191.52	1,915.20
Food Grade Receptacle w/lid 55 gal Blue	55620B	\$ 336.00	\$ 201.60	10	191.52	1,915.20
Food Grade Receptacle w/lid 20 gal Red	20584R	\$ 283.50	\$ 170.10	20	161.60	3,231.90
Food Grade Receptacle w/lid 22 gal Red	22584R	\$ 283.50	\$ 170.10	20	161.60	3,231.90
Food Grade Receptacle w/lid 25 gal Red	25584R	\$ 283.50	\$ 170.10	20	161.60	3,231.90
Food Grade Receptacle w/lid 30 gal Red	30584R	\$ 283.50	\$ 170.10	20	161.60	3,231.90
Food Grade Receptacle w/lid 35 gal Red	35584R	\$ 336.00	\$ 201.60	10	191.52	1,915.20
Food Grade Receptacle w/lid 40 gal Red	40584R	\$ 336.00	\$ 201.60	10	191.52	1,915.20
Food Grade Receptacle w/lid 45 gal Red	45584R	\$ 336.00	\$ 201.60	10	191.52	1,915.20
Food Grade Receptacle w/lid 50 gal Red	50584R	\$ 336.00	\$ 201.60	10	191.52	1,915.20
Food Grade Receptacle w/lid 55 gal Red	55584R	\$ 336.00	\$ 201.60	10	191.52	1,915.20
Food Grade Receptacle w/lid 20 gal White	202W	\$ 283.50	\$ 170.10	20	161.60	3,231.90
Food Grade Receptacle w/lid 22 gal White	222W	\$ 283.50	\$ 170.10	20	161.60	3,231.90
Food Grade Receptacle w/lid 25 gal White	252W	\$ 283.50	\$ 170.10	20	161.60	3,231.90
Food Grade Receptacle w/lid 30 gal White	302W	\$ 283.50	\$ 170.10	20	161.60	3,231.90
Food Grade Receptacle w/lid 35 gal White	352W	\$ 336.00	\$ 201.60	10	191.52	1,915.20
Food Grade Receptacle w/lid 40 gal White	402W	\$ 336.00	\$ 201.60	10	191.52	1,915.20
Food Grade Receptacle w/lid 45 gal White	452W	\$ 336.00	\$ 201.60	10	191.52	1,915.20
Food Grade Receptacle w/lid 50 gal White	502W	\$ 336.00	\$ 201.60	10	191.52	1,915.20
Food Grade Receptacle w/lid 55 gal White	552W	\$ 336.00	\$ 201.60	10	191.52	1,915.20
Food Grade Receptacle w/lid 20 gal Yellow	20451Y	\$ 283.50	\$ 170.10	20	161.60	3,231.90
Food Grade Receptacle w/lid 22 gal Yellow	22451Y	\$ 283.50	\$ 170.10	20	161.60	3,231.90
Food Grade Receptacle w/lid 25 gal Yellow	25451Y	\$ 283.50	\$ 170.10	20	161.60	3,231.90
Food Grade Receptacle w/lid 30 gal Yellow	30451Y	\$ 283.50	\$ 170.10	20	161.60	3,231.90
Food Grade Receptacle w/lid 35 gal Yellow	35451Y	\$ 336.00	\$ 201.60	10	191.52	1,915.20

Change Notice 2, Contract No. 200000000373

Correctional Technologies, Inc.

2025 Price List

FOOD SERVICE and FACILITY MAINTENANCE

DESCRIPTION	PART NUMBER	2025 LIST PRICE EACH	2025 SOM PRICE EACH (Delivered)	2025 QUANTITY PER FULL SKID	2025 SOM PRICE EACH PER SKID (Delivered)	2025 SOM TOTAL PRICE PER SKID (Delivered)
Food Grade Receptacle w/lid 40 gal Yellow	40451Y	\$ 336.00	\$ 201.60	10	191.52	1,915.20
Food Grade Receptacle w/lid 45 gal Yellow	45451Y	\$ 336.00	\$ 201.60	10	191.52	1,915.20
Food Grade Receptacle w/lid 50 gal Yellow	50451Y	\$ 336.00	\$ 201.60	10	191.52	1,915.20
Food Grade Receptacle w/lid 55 gal Yellow	55451Y	\$ 336.00	\$ 201.60	10	191.52	1,915.20
Food Grade Receptacle w/lid 20 gal Black	20116B	\$ 283.50	\$ 170.10	20	161.60	3,231.90
Food Grade Receptacle w/lid 22 gal Black	22116B	\$ 283.50	\$ 170.10	20	161.60	3,231.90
Food Grade Receptacle w/lid 25 gal Black	25116B	\$ 283.50	\$ 170.10	20	161.60	3,231.90
Food Grade Receptacle w/lid 30 gal Black	30116B	\$ 283.50	\$ 170.10	20	161.60	3,231.90
Food Grade Receptacle w/lid 35 gal Black	35116B	\$ 336.00	\$ 201.60	10	191.52	1,915.20
Food Grade Receptacle w/lid 40 gal Black	40116B	\$ 336.00	\$ 201.60	10	191.52	1,915.20
Food Grade Receptacle w/lid 45 gal Black	45116B	\$ 336.00	\$ 201.60	10	191.52	1,915.20
Food Grade Receptacle w/lid 50 gal Black	50116B	\$ 336.00	\$ 201.60	10	191.52	1,915.20
Food Grade Receptacle w/lid 55 gal Black	55116B	\$ 336.00	\$ 201.60	10	191.52	1,915.20
Flame Retardant Receptacle w/lid 20 gal Gray	20200FR	\$ 325.50	\$ 195.30	20	185.54	3,710.70
Flame Retardant Receptacle w/lid 22 gal Gray	22200FR	\$ 325.50	\$ 195.30	20	185.54	3,710.70
Flame Retardant Receptacle w/lid 25 gal Gray	25200FR	\$ 325.50	\$ 195.30	20	185.54	3,710.70
Flame Retardant Receptacle w/lid 30 gal Gray	30200FR	\$ 325.50	\$ 195.30	20	185.54	3,710.70
Flame Retardant Receptacle w/lid 35 gal Gray	35200FR	\$ 399.00	\$ 239.40	10	227.43	2,274.30
Flame Retardant Receptacle w/lid 40 gal Gray	40200FR	\$ 399.00	\$ 239.40	10	227.43	2,274.30
Flame Retardant Receptacle w/lid 45 gal Gray	45200FR	\$ 399.00	\$ 239.40	10	227.43	2,274.30
Flame Retardant Receptacle w/lid 50 gal Gray	50200FR	\$ 399.00	\$ 239.40	10	227.43	2,274.30
Flame Retardant Receptacle w/lid 55 gal Gray	55200FR	\$ 399.00	\$ 239.40	10	227.43	2,274.30
Flame Retardant Receptacle w/lid 20 gal Blue	20680FR	\$ 325.50	\$ 195.30	20	185.54	3,710.70
Flame Retardant Receptacle w/lid 22 gal Blue	22680FR	\$ 325.50	\$ 195.30	20	185.54	3,710.70
Flame Retardant Receptacle w/lid 25 gal Blue	25680FR	\$ 325.50	\$ 195.30	20	185.54	3,710.70
Flame Retardant Receptacle w/lid 30 gal Blue	30680FR	\$ 325.50	\$ 195.30	20	185.54	3,710.70
Flame Retardant Receptacle w/lid 35 gal Blue	35680FR	\$ 399.00	\$ 239.40	10	227.43	2,274.30

Change Notice 2, Contract No. 200000000373

Correctional Technologies, Inc.

2025 Price List

FOOD SERVICE and FACILITY MAINTENANCE

DESCRIPTION	PART NUMBER	2025 LIST PRICE EACH	2025 SOM PRICE EACH (Delivered)	2025 QUANTITY PER FULL SKID	2025 SOM PRICE EACH PER SKID (Delivered)	2025 SOM TOTAL PRICE PER SKID (Delivered)
Flame Retardant Receptacle w/lid 40 gal Blue	40680FR	\$ 399.00	\$ 239.40	10	227.43	2,274.30
Flame Retardant Receptacle w/lid 45 gal Blue	45680FR	\$ 399.00	\$ 239.40	10	227.43	2,274.30
Flame Retardant Receptacle w/lid 50 gal Blue	50680FR	\$ 399.00	\$ 239.40	10	227.43	2,274.30
Flame Retardant Receptacle w/lid 55 gal Blue	55680FR	\$ 399.00	\$ 239.40	10	227.43	2,274.30
Flame Retardant Receptacle w/lid 20 gal Green	20783FR	\$ 325.50	\$ 195.30	20	185.54	3,710.70
Flame Retardant Receptacle w/lid 22 gal Green	22783FR	\$ 325.50	\$ 195.30	20	185.54	3,710.70
Flame Retardant Receptacle w/lid 25 gal Green	25783FR	\$ 325.50	\$ 195.30	20	185.54	3,710.70
Flame Retardant Receptacle w/lid 30 gal Green	30783FR	\$ 325.50	\$ 195.30	20	185.54	3,710.70
Flame Retardant Receptacle w/lid 35 gal Green	35783FR	\$ 399.00	\$ 239.40	10	227.43	2,274.30
Flame Retardant Receptacle w/lid 40 gal Green	40783FR	\$ 399.00	\$ 239.40	10	227.43	2,274.30
Flame Retardant Receptacle w/lid 45 gal Green	45783FR	\$ 399.00	\$ 239.40	10	227.43	2,274.30
Flame Retardant Receptacle w/lid 50 gal Green	50783FR	\$ 399.00	\$ 239.40	10	227.43	2,274.30
Flame Retardant Receptacle w/lid 55 gal Green	55783FR	\$ 399.00	\$ 239.40	10	227.43	2,274.30
Kangaroo Cart Black Repro material	CC116	\$ 787.50	\$ 472.50	8	448.88	3,591.00
Kangaroo Cart White Food Grade Material	CC2	\$ 808.50	\$ 485.10	8	460.85	3,686.76
Kangaroo Cart Green Food Grade Material	CC720	\$ 808.50	\$ 485.10	8	460.85	3,686.76
Kangaroo Cart Gray Food Grade Material	CC280	\$ 808.50	\$ 485.10	8	460.85	3,686.76
Kangaroo Cart Blue Food Grade Material	CC620	\$ 808.50	\$ 485.10	8	460.85	3,686.76
Kangaroo Cart Blue/Gray Flame Retardant Material	CC200	\$ 924.00	\$ 554.40	8	526.68	4,213.44
Kangaroo Cart Green Flame Retardant Material	CC783	\$ 924.00	\$ 554.40	8	526.68	4,213.44
Kangaroo Cart Blue Flame Retardant Material	CC680	\$ 924.00	\$ 554.40	8	526.68	4,213.44
Kangaroo Cart Lid Black Repro material	CC116L	\$ 319.20	\$ 191.52	8	181.94	1,455.55
Kangaroo Cart Lid White Food Grade Material	CC2L	\$ 319.20	\$ 191.52	8	181.94	1,455.55
Kangaroo Cart Lid Green Food Grade Material	CC720L	\$ 319.20	\$ 191.52	8	181.94	1,455.55
Kangaroo Cart Lid Gray Food Grade Material	CC280L	\$ 319.20	\$ 191.52	8	181.94	1,455.55
Kangaroo Cart Lid Blue Food Grade Material	CC620L	\$ 319.20	\$ 191.52	8	181.94	1,455.55
Kangaroo Cart Lid Blue/Gray Flame Retardant Material	CC200L	\$ 336.00	\$ 201.60	8	191.52	1,532.16

Change Notice 2, Contract No. 200000000373

Correctional Technologies, Inc.

2025 Price List

FOOD SERVICE and FACILITY MAINTENANCE

DESCRIPTION	PART NUMBER	2025 LIST PRICE EACH	2025 SOM PRICE EACH (Delivered)	2025 QUANTITY PER FULL SKID	2025 SOM PRICE EACH PER SKID (Delivered)	2025 SOM TOTAL PRICE PER SKID (Delivered)
Kangaroo Cart Lid Green Flame Retardant Material	CC783L	\$ 336.00	\$ 201.60	8	191.52	1,532.16
Kangaroo Cart Lid Blue Flame Retardant Material	CC680L	\$ 336.00	\$ 201.60	8	191.52	1,532.16
Tiger Plate Single Switch	TPSS	\$ 18.90	\$ 11.34	10	10.77	107.73
Tiger Plate Single Duplex	TPDR	\$ 18.90	\$ 11.34	10	10.77	107.73
Tiger Plate Single Blank	TPBB	\$ 16.80	\$ 10.08	10	9.58	95.76
Tiger Plate Single GFI	TPGF	\$ 16.80	\$ 10.08	10	9.58	95.76
Tiger Plate Double Blank	TPDBB	\$ 21.00	\$ 12.60	10	11.97	119.70
Tiger Plate Double Duplex	TPDD	\$ 21.00	\$ 12.60	10	11.97	119.70
Tiger Plate Double GFI	TPDGF	\$ 21.00	\$ 12.60	10	11.97	119.70
Tiger Plate Double Switch	TPDS	\$ 21.00	\$ 12.60	10	11.97	119.70

Change Notice 2, Contract No. 200000000373

Correctional Technologies, Inc.

2025 Price List

CORNER GUARDS - ALL SOLD IN CASES OF 20

DESCRIPTION	PART NUMBER	2025 LIST PRICE EACH	2025 SOM PRICE PER CASE
CORNER GUARD BEIGE GRAIN	CGTBG	\$ 16.00	\$ 192.00
CORNER GUARD BLUE GRAIN	CGTBL	\$ 16.00	\$ 192.00
CORNER GUARD WHITE GRAIN	CGTWH	\$ 16.00	\$ 192.00
CORNER GUARD 1X1X48 ALMOND	CGA1X1X48A	\$ 17.64	\$ 211.68
CORNER GUARD 1X1X48 ALMOND FR	CGA1X1X48FR	\$ 17.64	\$ 211.68
CORNER GUARD 2X2X48 ALMOND	CGA2X2X48A	\$ 20.58	\$ 246.96
CORNER GUARD 2X2X48 ALMOND FR	CGA2X2X48FR	\$ 20.58	\$ 246.96
CORNER GUARD 3X3X48 ALMOND	CGA3X3X48A	\$ 23.52	\$ 282.24
CORNER GUARD 3X3X48 ALMOND FR	CGA3X3X48FR	\$ 23.52	\$ 282.24
CORNER GUARD 4X4X48 ALMOND	CGA4X4X48A	\$ 26.46	\$ 317.52
CORNER GUARD 4X4X48 ALMOND FR	CGA4X4X48FR	\$ 26.46	\$ 317.52
CORNER GUARD BULLNOSE 2.5"X 48 ALMOND W/AD	CGABNA	\$ 17.64	\$ 211.68
CORNER GUARD BULLNOSE 2.5" X 48 ALMOND FR	CGABNFR	\$ 17.64	\$ 211.68
CORNER GUARD 1X1X48 BLACK	CGB1X1X48A	\$ 17.64	\$ 211.68
CORNER GUARD 1X1X48 BLACK FR	CGB1X1X48FR	\$ 17.64	\$ 211.68
CORNER GUARD 2X2X48 BLACK	CGB2X2X48A	\$ 20.58	\$ 246.96
CORNER GUARD 2X2X48 BLACK FR	CGB2X2X48FR	\$ 20.58	\$ 246.96
CORNER GUARD 3X3X48 BLACK	CGB3X3X48A	\$ 23.52	\$ 282.24
CORNER GUARD 3X3X48 BLACK FR	CGB3X3X48FR	\$ 23.52	\$ 282.24
CORNER GUARD 4X4X48 BLACK	CGB4X4X48A	\$ 26.46	\$ 317.52
CORNER GUARD 4X4X48 BLACK FR	CGB4X4X48FR	\$ 26.46	\$ 317.52
CORNER GUARD BULLNOSE 2.5"X48 BLACK W/AD	CGBBNA	\$ 17.64	\$ 211.68
CORNER GUARD BULLNOSE 2.5"X48" BLACK FR	CGBBNFR	\$ 17.64	\$ 211.68
CORNER GUARD 1X1X48 CLEAR	CGC1X1X48	\$ 17.64	\$ 211.68
CORNER GUARD 2X2X48 CLEAR	CGC2X2X48	\$ 20.58	\$ 246.96
CORNER GUARD 3X3X48 CLEAR	CGC3X3X48	\$ 23.52	\$ 282.24
CORNER GUARD 4X4X48 CLEAR	CGC4X4X48	\$ 26.46	\$ 317.52
CORNER GUARD BULLNOSE 2.5" X 48 CLEAR	CGCBN	\$ 17.64	\$ 211.68
CORNER GUARD 1X1X48 EGGSHELL W/AD	CGE1X1X48A	\$ 17.64	\$ 211.68
CORNER GUARD 1X1X48 EGGSHELL FR	CGE1X1X48FR	\$ 17.64	\$ 211.68
CORNER GUARD 2X2X48 EGGSHELL W/AD	CGE2X2X48A	\$ 20.58	\$ 246.96
CORNER GUARD 2X2X48 EGGSHELL FR	CGE2X2X48FR	\$ 20.58	\$ 246.96
CORNER GUARD 3X3X48 EGGSHELL W/AD	CGE3X3X48A	\$ 23.52	\$ 282.24
CORNER GUARD 3x3x48 EGGSHELL FR	CGE3X3X48FR	\$ 23.52	\$ 282.24
CORNER GUARD 4X4X48 EGGSHELL W/AD	CGE4X4X48A	\$ 26.46	\$ 317.52

Change Notice 2, Contract No. 200000000373

Correctional Technologies, Inc.

2025 Price List

CORNER GUARDS - ALL SOLD IN CASES OF 20

DESCRIPTION	PART NUMBER	2025 LIST PRICE EACH	2025 SOM PRICE PER CASE
CORNER GUARD 4X4X48 EGGSHELL FR	CGE4X4X48FR	\$ 26.46	\$ 317.52
CORNER GUARD BULLNOSE 2.5"X48 EGGSHELL W/A	CGEBNA	\$ 17.64	\$ 211.68
CORNER GUARD BULLNOSE 2.5"X48 EGGSHELL FR	CGEBNFR	\$ 17.64	\$ 211.68
CORNER GUARD 1X1X48 GRAY W/AD	CGG1X1X48A	\$ 17.64	\$ 211.68
CORNER GUARD 1X1X48 GRAY FR	CGG1X1X48FR	\$ 17.64	\$ 211.68
CORNER GUARD 2X2X48 GRAY W/AD	CGG2X2X48A	\$ 20.58	\$ 246.96
CORNER GUARD 2X2X48 GRAY FR	CGG2X2X48FR	\$ 20.58	\$ 246.96
CORNER GUARD 3X3X48 GRAY W/AD	CGG3X3X48A	\$ 23.52	\$ 282.24
CORNER GUARD 3X3X48 GRAY FR	CGG3X3X48FR	\$ 23.52	\$ 282.24
CORNER GUARD 4X4X48 GRAY W/AD	CGG4X4X48A	\$ 26.46	\$ 317.52
CORNER GUARD 4X4X48 GRAY FR	CGG4X4X48FR	\$ 26.46	\$ 317.52
CORNER GUARD BULLNOSE 2.5"X48 GRAY W/AD	CGGBNA	\$ 17.64	\$ 211.68
CORNER GUARD BULLNOSE 2.5" X 48 GRAY FR	CGGBNFR	\$ 17.64	\$ 211.68
CORNER GUARD 1X1X48 BRONZE W/AD	CGH1X1X48A	\$ 17.64	\$ 211.68
CORNER GUARD 1X1X48 BRONZE FR	CGH1X1X48FR	\$ 17.64	\$ 211.68
CORNER GUARD 2X2X48 BRONZE W/AD	CGH2X2X48A	\$ 20.58	\$ 246.96
CORNER GUARD 2X2X48 BRONZE FR	CGH2X2X48FR	\$ 20.58	\$ 246.96
CORNER GUARD 3X3X48 BRONZE W/AD	CGH3X3X48A	\$ 23.52	\$ 282.24
CORNER GUARD 3X3X48 BRONZE FR	CGH3X3X48FR	\$ 23.52	\$ 282.24
CORNER GUARD 4X4X48 BRONZE W/AD	CGH4X4X48A	\$ 26.46	\$ 317.52
CORNER GUARD 4X4X48 BRONZE FR	CGH4X4X48FR	\$ 26.46	\$ 317.52
CORNER GUARD BULLNOSE 2.5"X48 BRONZE W/AD	CGHBNA	\$ 17.64	\$ 211.68
CORNER GUARD BULLNOSE 2.5" X 48 BRONZE FR	CGHBNFR	\$ 17.64	\$ 211.68
CORNER GUARD 1X1X48 SILVER W/AD	CGS1X1X48A	\$ 17.64	\$ 211.68
CORNER GUARD 1X1X48 SILVER FR	CGS1X1X48FR	\$ 17.64	\$ 211.68
CORNER GUARD 2X2X48 SILVER W/AD	CGS2X2X48A	\$ 20.58	\$ 246.96
CORNER GUARD 2X2X48 SILVER FR	CGS2X2X48FR	\$ 20.58	\$ 246.96
CORNER GUARD 3X3X48 SILVER W/AD	CGS3X3X48A	\$ 23.52	\$ 282.24
CORNER GUARD 3X3X48 SILVER FR	CGS3X3X48FR	\$ 23.52	\$ 282.24
CORNER GUARD 4X4X48 SILVER W/AD	CGS4X4X48A	\$ 26.46	\$ 317.52
CORNER GUARD 4X4X48 SILVER FR	CGS4X4X48FR	\$ 26.46	\$ 317.52
CORNER GUARD BULLNOSE 2.5"X 48 SILVER W/AD	CGSBNA	\$ 17.64	\$ 211.68
CORNER GUARD BULLNOSE 2.5" X 48 SILVER FR	CGSBNFR	\$ 17.64	\$ 211.68
CORNER GUARD 1X1X48 WHITE W/AD	CGW1X1X48A	\$ 17.64	\$ 211.68
CORNER GUARD 1X1X48 WHITE FR	CGW1X1X48FR	\$ 17.64	\$ 211.68

Change Notice 2, Contract No. 200000000373

Correctional Technologies, Inc.

2025 Price List

CORNER GUARDS - ALL SOLD IN CASES OF 20

DESCRIPTION	PART NUMBER	2025 LIST PRICE EACH	2025 SOM PRICE PER CASE
CORNER GUARD 2X2X48 WHITE W/AD	CGW2X2X48A	\$ 20.58	\$ 246.96
CORNER GUARD 2X2X48 WHITE FR	CGW2X2X48FR	\$ 20.58	\$ 246.96
CORNER GUARD 3X3X48 WHITE W/AD	CGW3X3X48A	\$ 23.52	\$ 282.24
CORNER GUARD 3X3X48 WHITE FR	CGW3X3X48FR	\$ 23.52	\$ 282.24
CORNER GUARD 4X4X48 WHITE W/AD	CGW4X4X48A	\$ 26.46	\$ 317.52
CORNER GUARD 4X4X48 WHITE FR	CGW4X4X48FR	\$ 26.46	\$ 317.52
CORNER GUARD BULLNOSE 2.5"X48 WHITE W/AD	CGWBNA	\$ 17.64	\$ 211.68
CORNER GUARD BULLNOSE 2.5" X 48 WHITE FR	CGWBNFR	\$ 17.64	\$ 211.68
CORNER GUARD 1X1X48 YELLOW W/AD	CGY1X1X48A	\$ 17.64	\$ 211.68
CORNER GUARD 1X1X48 YELLOW FR	CGY1X1X48FR	\$ 17.64	\$ 211.68
CORNER GUARD 2X2X48 YELLOW W/AD	CGY2X2X48A	\$ 20.58	\$ 246.96
CORNER GUARD 2X2X48 YELLOW FR	CGY2X2X48FR	\$ 20.58	\$ 246.96
CORNER GUARD 3X3X48 YELLOW W/AD	CGY3X3X48A	\$ 23.52	\$ 282.24
CORNER GUARD 3X3X48 YELLOW FR	CGY3X3X48FR	\$ 23.52	\$ 282.24
CORNER GUARD 4X4X48 YELLOW W/AD	CGY4X4X48A	\$ 26.46	\$ 317.52
CORNER GUARD 4X4X48 YELLOW FR	CGY4X4X48FR	\$ 26.46	\$ 317.52
CORNER GUARD BULLNOSE 2.5"X48 YELLOW W/AD	CGYBNA	\$ 17.64	\$ 211.68
CORNER GUARD BULLNOSE 2.5" X 48 YELLOW FR	CGYBNFR	\$ 17.64	\$ 211.68
Corner Guard Diamond Tread Silver 3x3 w/screws	CGDS3x3x48FR	\$ 26.46	\$ 317.52
Corner Guard Diamond Tread Silver 4x4 w/screws	CGDS4x4x48FR	\$ 29.40	\$ 352.80
Corner Guard Diamond Tread Yellow 3x3 w/screws	CGDY3x3x48FR	\$ 26.46	\$ 317.52
Corner Guard Diamond Tread Yellow 4x4 w/screws	CGDY4x4x48FR	\$ 26.46	\$ 317.52

STATE OF MICHIGAN

Contract No. 200000000373
Statewide – Anti-Ligature Furnishing Services

SCHEDULE C PRODUCT SPECIFICATIONS

Michigan Department of Health and Human Services (MDHHS) Hospitals:

1. Caro Center
 - a. 2000 Chambers Road, Caro, MI 48723
2. Center for Forensic Psychiatry (CFP)
 - a. 8303 Platt Road, Saline, MI 48176
3. Hawthorn Center
 - a. 18471 Haggerty Road, Northville, MI 48167
4. Kalamazoo Psychiatric Hospital (KPH)
 - a. 1312 Oakland Drive, Kalamazoo, MI 49008
5. Walter Reuther Psychiatric Hospital (WRPH)
 - a. 30901 Palmer Road, Westland, MI 48186

Additional MDHHS Facility:

1. Juvenile Justice Residential (JJB) Facility
 - a. Bay pines Center
 - i. 2425 N 30th Street, Escanaba, MI 49829
 - b. Shawono Center
 - i. 10 N Howes Lake Road, Grayling, MI 49738

BJJ Centers:

- Bay Pines Center
- Shawono Center

Please note the following items are a general list of items currently utilized, items listed are an indicator of future need and are in no way a guarantee of items to be purchased by the State in the future.

In Section 1.1 Product Specifications, of Schedule A – Statement of Work, please confirm that items offered by your Organization will meet the minimum requirements show below.

Special Notes:

1. Classroom furnishings must be youth appropriate for high security residential living.
2. Classroom furnishings must allow for arrangement around the perimeter of the room, to allow for the teachers' station to have no youth desk to their back.
3. It is preferred that desks/workstations be adjustable and are movable with locking wheels If applicable.
4. Desks/workstations must be made of materials that not breakable, that can withstand hitting, kicking and other means of force, or easily throw.
5. Desks/workstations cannot have components, pieces or parts that can be removed easily, taken or broken off.
6. Each desk/workstation should have some a partition/divider on the underneath to prevent physical contact from another desk/workstation.
7. The following products must be new, fire-retardant polyethylene; the following are anticipated items for purchase:
 - a. Classroom – Seating, Chairs
 - b. Classroom Seating, Desks
 - c. Classroom Teachers Desk



STATE OF MICHIGAN
CENTRAL PROCUREMENT SERVICES
 Department of Technology, Management, and Budget
 320 S. WALNUT ST., LANSING, MICHIGAN 48933
 P.O. BOX 30026 LANSING, MICHIGAN 48909

CONTRACT CHANGE NOTICE

Change Notice Number **4**
 to
 Contract Number **200000000373**

CONTRACTOR	CORRECTIONAL TECHNOLOGIES, INC.
	7530 Plaza Court
	Willowbrook, IL 60527
	Steve Csuk
	630-445-0811
	steve@cortechusa.com
	CV0017523

STATE	Program Manager	Various	MDHHS
	Contract Administrator	Susan Watt-Smith	DTMB
		517-230-0535	
		wattsmiths@michigan.gov	

CONTRACT SUMMARY

ANTI-LIGATURE FURNISHING SERVICES - STATEWIDE

INITIAL EFFECTIVE DATE	INITIAL EXPIRATION DATE	INITIAL AVAILABLE OPTIONS	EXPIRATION DATE BEFORE
February 1, 2020	January 31, 2025	5 - 1 Year	January 31, 2025
PAYMENT TERMS		DELIVERY TIMEFRAME	
1NET10; 1½ NET15; NET 45		N/A	
ALTERNATE PAYMENT OPTIONS			EXTENDED PURCHASING
<input type="checkbox"/> P-Card <input type="checkbox"/> PRC <input type="checkbox"/> Other			<input checked="" type="checkbox"/> Yes <input type="checkbox"/> No

MINIMUM DELIVERY REQUIREMENTS

N/A

DESCRIPTION OF CHANGE NOTICE

OPTION	LENGTH OF OPTION	EXTENSION	LENGTH OF EXTENSION	REVISED EXP. DATE
<input type="checkbox"/>		<input type="checkbox"/>		January 31, 2025
CURRENT VALUE	VALUE OF CHANGE NOTICE	ESTIMATED AGGREGATE CONTRACT VALUE		
\$2,245,000.00	\$0.00	\$2,245,000.00		

DESCRIPTION

Effective September 8, 2023, the updates in Change Notice 4, Attachment 1 are incorporated.

Additionally, please note Lauri Bonnell replaces Michael Roesner as the State Program Manager for MDHHS, 517-335-0175, BonnellL@michigan.gov

All other terms, conditions, specifications and pricing remain the same. Per contractor and agency agreement, and DTMB Central Procurement approval.

**Program Managers
for
Multi-Agency and Statewide Contracts**

AGENCY	NAME	PHONE	EMAIL
MDHHS	Lauri Bonnell	517-335-0175	BonnellL@michigan.gov
MDOC	Eames E. Groenleer	517-780-6076	GroenleerE@michigan.gov
MDOC	George B. Sevarns	906-293-0005	SevarnsG@michigan.gov

Change Notice 4, Attachment 1
Contract No. 20000000373

The attached Schedule B, Pricing updates and replaces the previous Schedule B, which incorporates:

Added Items:

- 1) **ENDURANCE TABLE 42" SQUARE X BASE** (Contractor Item numbers below): Game top: Contract price- \$575 ea. for full skid quantity (4) or more OR \$600 ea. Plain top: Contract price \$500 ea. for full skid quantity (4) or more OR \$550 ea.

PLAIN TOP	GAME TOP	SIZE	COLOR
66750AQ	66750AQGT	42" Square	Aqua
66750BK	66750BKGT	42" Square	Black
66750BG	66750BGGT	42" Square	Blue Gray
66750BN	66750BNGT	42" Square	Brown
66750BY	66750BYGT	42" Square	Burgundy
66750GY	66750GYGT	42" Square	Gray
66750GN	66750GNGT	42" Square	Green
66750IG	66750IGGT	42" Square	Indigo
66750MB	66750MBGT	42" Square	Midnight Blue
66750SD	66750SDGT	42" Square	Sand
66750SB	66750SBGT	42" Square	Slate Blue
66750SG	66750SGGT	42" Square	Stone Gray

- 2) **710GYCS- TRASH CAN GRAY 10QT FR (6 PK):**
Contract price- \$105.17 ea./pk for full skid quantity (20 pk) OR \$130 ea./pk

- 3) **7901BK- ENDURANCE FLOOR STOOL BLACK 13X13X16:**
Contract price- \$109.01 ea. for full skid quantity (30) OR \$130 ea.

- 4) **25200FR-Container 25 Gal Blue Gray FR:**
Contract price- \$155.00

Discontinued Items:

- 1) See-clear-ity Correctional Mattress 3 x 25 x 75 no pillows ****DISCONTINUED****
- 2) EZ Gator Suit Suicide Smock ****DISCONTINUED****
- 3) Clear Visitation Table 40" Round ****DISCONTINUED****

STATE OF MICHIGAN

Contract No. 200000000373
Statewide – Anti-Ligature Furnishing Services
Change Notice 4

SCHEDULE B PRICING

1. Price proposals must include all costs, including but not limited to, any one-time or set-up charges, fee, and potential costs that Contractor may charge the State (e.g. shipping and handling, per piece pricing and palletizing).
2. Quick payment terms: 1 % discount off invoice if paid within 10 days after receipt of invoice.
Quick payment terms: 1½ % discount off invoice if paid within 15 days after receipt of invoice.
3. Quantity/Volume terms:
 - Quantity discount 5% off orders greater than \$50,000.00
 - Year-to-Date Total Quantity discount: An additional 5% discount will be applied on year-to-date orders exceed \$100,000.00, for the remained of the calendar year, to be rest annually.
 - Freight included Pricing for items listed in Schedule B – The contractor will re-calculate freight to include and exclude freight as a separate line item when freight is less than the Current List Pricing with Freight Included Pricing. The Contractor with the State on an order-by-order basis to determine best pricing for freight.

Updated pricing on following pages

DESCRIPTION	PART NUMBER	Single Item Price	Skid Qty per piece	Skid Qty
Furniture, Seating & Mattresses				
EZ Bunk(TM) Sleep Surface Grey	7501	\$332.17	\$185.00	20
EZ Bunk(TM) Sleep Surface Blue	7502	\$332.17	\$185.00	20
Barracuda Box 1.5 cu ft	3825P	\$51.17	\$28.00	32
Barracuda Box 2.0 cu ft	7268P	\$52.77	\$29.07	32
Barracuda Box Lid universal	9689	\$48.02	\$23.00	32
Barracuda Box 3.0 cu ft	8568P	\$63.09	\$50.00	18
Barracuda Box Lid for 3.0 cu ft	8289P	\$51.78	\$28.64	64
Masterbox 1.5	3825M	\$63.45	\$42.75	32
Masterbox 2.0	7268M	\$65.17	\$50.00	32
Masterbox 1.5/2.0 Lid	9689M	\$52.44	\$24.00	128
Masterbox 3.0	8568M	\$74.84	\$66.00	18
Masterbox 3.0 Lid	8289M	\$56.30	\$31.00	64
Stackable Chair Slate Blue	86484SB	NA	\$36.00	50
Stackable Chair Blue Gray	86484BG	NA	\$36.00	50
Stackable Chair Buff	86484B	NA	\$36.00	50
Stackable Chair Plum	86484P	NA	\$36.00	50
Stackable Chair Fog Gray	86484FG	NA	\$36.00	50
Stackable Chair Black	86484BK	NA	\$36.00	50
Stackable Chair Teal	86484T	NA	\$36.00	50
Stackable Chair Green	86484GN	NA	\$43.00	50
Stackable Chair Brown	86484BN	NA	\$43.00	50
Stackable Chair Slate Blue	86484SB	NA	\$42.00	25
Stackable Chair Blue Gray	86484BG	NA	\$42.00	25
Stackable Chair Buff	86484B	NA	\$42.00	25

Stackable Chair Plum	86484P	NA	\$42.00	25
Stackable Chair Fog Gray	86484FG	NA	\$42.00	25
Stackable Chair Black	86484BK	NA	\$42.00	25
Stackable ChairTeal	86484T	NA	\$42.00	25
Stackable Chair Green	86484GN	NA	\$50.00	25
Stackable Chair Brown	86484BN	NA	\$50.00	25
Sabre Chair-floor mount, gangable Black	96484BK	\$284.91	\$223.00	4
Sabre Chair-floor mount, gangable Grey	96484GY	\$284.91	\$223.00	4
Sabre Chair-floor mount, gangable Slate Blue	96484SB	\$284.91	\$223.00	4
Sabre Chair-floor mount, gangable Brown	96484BN	\$284.91	\$223.00	4
Sabre Chair-floor mount, gangable Green	96484GN	\$284.91	\$223.00	4
Sabre Chair-floor mount, gangable Blue Grey	96484BG	\$284.91	\$223.00	4
Sabre Chair-floor mount, gangable Sand	96484SD	\$284.91	\$223.00	4
Sabre Chair-floor mount, gangable Burgundy	96484BY	\$284.91	\$223.00	4
Sabre Chair floor mount, gangable with access door Black	96484BKS	\$312.90	\$260.00	4
Sabre Chair floor mount, gangable with access door Grey	96484GYS	\$312.90	\$260.00	4
Sabre Chair floor mount, gangable with access door Slate Blue	96484SBS	\$312.90	\$260.00	4
Sabre Chair floor mount, gangable with access door Brown	96484BNS	\$312.90	\$260.00	4
Sabre Chair floor mount, gangable with access door Green	96484GNS	\$312.90	\$260.00	4
Sabre Chair floor mount, gangable with access door Blue Grey	96484BGS	\$312.90	\$260.00	4
Sabre Chair floor mount, gangable with access door Sand	96484SDS	\$312.90	\$260.00	4
Sabre Chair floor mount, gangable with access door Burgundy	96484BYS	\$312.90	\$260.00	4
Sentinel Armless Chair-floor mount, gangable Black	116484BK	\$271.81	\$175.00	8
Sentinel Armless Chair-floor mount, gangable Grey	116484GY	\$271.81	\$175.00	8
Sentinel Armless Chair-floor mount, gangable Slate Blue	116484SB	\$271.81	\$175.00	8
Sentinel Armless Chair-floor mount, gangable Brown	116484BN	\$271.81	\$175.00	8
Sentinel Armless Chair-floor mount, gangable Green	116484GN	\$271.81	\$175.00	8
Sentinel Armless Chair-floor mount, gangable Blue Grey	116484BG	\$271.81	\$175.00	8

Sentinel Armless Chair-floor mount, gangable Burgundy	116484BY	\$271.81	\$175.00	8
Sentinel Armless Chair-floor mount, gangable Sand	116484SD	\$271.81	\$175.00	8
Sentinel Armless Chair floor mount, gangable with access door Black	116484BKS	\$298.98	\$212.00	8
Sentinel Armless Chair floor mount, gangable with access door Grey	116484GYS	\$298.98	\$212.00	8
Sentinel Armless Chair floor mount, gangable with access door Slate Blue	116484SBS	\$298.98	\$212.00	8
Sentinel Armless Chair floor mount, gangable with access door Brown	116484BNS	\$298.98	\$212.00	8
Sentinel Armless Chair floor mount, gangable with access door Green	116484GNS	\$298.98	\$212.00	8
Sentinel Armless Chair floor mount, gangable with access door Blue Grey	116484BGS	\$298.98	\$212.00	8
Sentinel Armless Chair floor mount, gangable with access door Sand	116484SDS	\$298.98	\$212.00	8
Sentinel Armless Chair floor mount, gangable with access door Burgundy	116484BYS	\$298.98	\$212.00	8
Sentinel Arm Chair-floor mount, gangable Black	106484BK	\$275.96	\$180.00	8
Sentinel Arm Chair-floor mount, gangable Grey	106484GY	\$275.96	\$180.00	8
Sentinel Arm Chair-floor mount, gangable Slate Blue	106484SB	\$275.96	\$180.00	8
Sentinel Arm Chair-floor mount, gangable Brown	106484BN	\$275.96	\$180.00	8
Sentinel Arm Chair-floor mount, gangable Green	106484GN	\$275.96	\$180.00	8
Sentinel Arm Chair-floor mount, gangable Blue Grey	106484BG	\$275.96	\$180.00	8
Sentinel Arm Chair-floor mount, gangable Sand	106484SD	\$275.96	\$180.00	8
Sentinel Arm Chair-floor mount, gangable Burgundy	106484BY	\$275.96	\$180.00	8
Sentinel Arm Chair floor mount, gangable with access door Black	106484BKS	\$293.08	\$204.00	8
Sentinel Arm Chair floor mount, gangable with access door Grey	106484GYS	\$293.08	\$204.00	8
Sentinel Arm Chair floor mount, gangable with access door Slate Blue	106484SBS	\$293.08	\$204.00	8
Sentinel Arm Chair floor mount, gangable with access door Brown	106484BNS	\$293.08	\$204.00	8
Sentinel Arm Chair floor mount, gangable with access door Green	106484GNS	\$293.08	\$204.00	8
Sentinel Arm Chair floor mount, gangable with access door Blue Grey	106484BGS	\$293.08	\$204.00	8
Sentinel Arm Chair floor mount, gangable with access door Sand	106484SDS	\$293.08	\$204.00	8
Sentinel Arm Chair floor mount, gangable with access door Burgundy	106484BYS	\$293.08	\$204.00	8
Radial Rocker Black	146484BK	\$420.00	\$375.00	2
Radial Rocker Grey	146484GY	\$420.00	\$375.00	2

Radial Rocker Slate Blue	146484SB	\$420.00	\$375.00	2
Radial Rocker Brown	146484BN	\$420.00	\$375.00	2
Radial Rocker Green	146484GN	\$420.00	\$375.00	2
Radial Rocker Blue Grey	146484BG	\$420.00	\$375.00	2
Radial Rocker Sand	146484SD	\$420.00	\$375.00	2
Radial Rocker Burgundy	146484BY	\$420.00	\$375.00	2
Endurance Bench Black	136484BK	\$485.00	\$453.15	10
Endurance Bench Blue Grey	136484BG	\$485.00	\$453.15	10
Endurance Bench Brown	136484BN	\$485.00	\$453.15	10
Endurance Bench Green	136484GN	\$485.00	\$453.15	10
Endurance Bench Grey	136484GY	\$485.00	\$453.15	10
Endurance Bench Slate Blue	136484SB	\$485.00	\$453.15	10
Endurance Bench Sand	136484SD	\$485.00	\$453.15	10
Endurance Bench Burgundy	136484BY	\$485.00	\$453.58	10
Endurance Cube Black	126484BK	\$267.46	\$196.65	18
Endurance Cube Blue Grey	126484BG	\$267.46	\$196.65	18
Endurance Cube Brown	126484BN	\$267.46	\$196.65	18
Endurance Cube Green	126484GN	\$267.46	\$196.65	18
Endurance Cube Grey	126484GY	\$267.46	\$196.65	18
Endurance Cube Slate Blue	126484SB	\$267.46	\$196.65	18
Endurance Cube Sand	126484SD	\$267.46	\$196.65	18
Endurance Cube Burgundy	126484BY	\$267.46	\$196.65	18
Endurance Cube Black with Access Door	126484BKS	\$294.63	\$222.30	18
Endurance Cube Blue Grey with Access Door	126484BGS	\$294.63	\$222.30	18
Endurance Cube Brown with Access Door	126484BNS	\$294.63	\$222.30	18
Endurance Cube Green with Access Door	126484GNS	\$294.63	\$222.30	18
Endurance Cube Grey with Access Door	126484GYS	\$294.63	\$222.30	18
Endurance Cube Slate Blue with Access Door	126484SBS	\$294.63	\$222.30	18

Endurance Cube Sand with Access Door	126484SDS	\$294.63	\$222.30	18
Endurance Cube Burgundy with Access Door	126484BYS	\$294.63	\$222.30	18
Trash Can Black 10 quart Flame Retardant (6 pack)	710-BK	\$130.00	\$105.17	120
Trash Can Grey 10 quart Flame Retardant (6 pack)	710-GY	\$130.00	\$105.17	120
Trash Can Slate Blue 10 quart Flame Retardant (6 pack)	710-SB	\$130.00	\$105.17	120
Trash Can Green 10 quart Flame Retardant (6 pack)	710-GN	\$130.00	\$105.17	120
Trash Can Brown 10 quart Flame Retardant (6 pack)	710-BN	\$130.00	\$105.17	120
Trash Can Blue Gray 10 quart Flame Retardant (6 pack)	710-BG	\$130.00	\$105.17	120
Trash Can Sand 10 quart Flame Retardant (6 pack)	710-SD	\$130.00	\$105.17	120
Trash Can Black 14 quart Flame Retardant (6 pack)	714-BK	\$135.00	\$112.86	120
Trash Can Grey 14 quart Flame Retardant (6 pack)	714-GY	\$135.00	\$112.86	120
Trash Can Slate Blue 14 quart Flame Retardant (6 pack)	714-SB	\$135.00	\$112.86	120
Trash Can Green 14 quart Flame Retardant (6 pack)	714-GN	\$135.00	\$112.86	120
Trash Can Blue Gray 14 quart Flame Retardant (6 pack)	714-BG	\$135.00	\$112.86	120
Trash Can Sand 14 quart Flame Retardant (6 pack)	714-SD	\$135.00	\$112.86	120
Trash Can Brown 14 quart Flame Retardant (6 pack)	714-BN	\$135.00	\$112.86	120
Acrylic Mirror 11x15	VM1115	N/A	\$48.74	Only Cases of 10
Acrylic Mirror 15x20	VM1520	N/A	\$64.13	Only Cases of 10
Acrylic Mirror 18x24	VM1824	N/A	\$85.50	Only Cases of 10
Endurance Bed 0.0, Black	7500BK	\$690.00	\$662.63	6
Endurance Bed 0.0, Slate Blue	7500SB	\$690.00	\$662.63	6
Endurance Bed 0.0, Green	7500GN	\$690.00	\$662.63	6
Endurance Bed 0.0, Brown	7500BN	\$690.00	\$662.63	6
Endurance Bed 0.0, Blue/Gray	7500BG	\$690.00	\$662.63	6
Endurance Bed 0.0, Grey	7500GY	\$690.00	\$662.63	6
Endurance Bed 0.0, Sand	7500SD	\$690.00	\$662.63	6
Endurance Bed 0.0, Burgundy	7500BY	\$690.00	\$662.63	6
Endurance Bed 1.0, Black	7601BK	\$715.00	\$684.00	4

Endurance Bed 1.0, Slate Blue	7601SB	\$715.00	\$684.00	4
Endurance Bed 1.0, Green	7601GN	\$715.00	\$684.00	4
Endurance Bed 1.0, Brown	7601BN	\$715.00	\$684.00	4
Endurance Bed 1.0, Blue/Gray	7601BG	\$715.00	\$684.00	4
Endurance Bed 1.0, Grey	7601GY	\$715.00	\$684.00	4
Endurance Bed 1.0, Sand	7601SD	\$715.00	\$684.00	4
Endurance Bed 1.0, Burgundy	7601BY	\$715.00	\$684.00	4
Endurance Bed 2.0 Black	7801BK	\$830.00	\$815.00	3
Endurance Bed 2.0 Slate Blue	7801SB	\$830.00	\$815.00	3
Endurance Bed 2.0 Green	7801GN	\$830.00	\$815.00	3
Endurance Bed 2.0 Brown	7801BN	\$830.00	\$815.00	3
Endurance Bed 2.0 Blue/Gray	7801BG	\$830.00	\$815.00	3
Endurance Bed 2.0 Grey	7801GY	\$830.00	\$815.00	3
Endurance Bed 2.0 Sand	7801SD	\$830.00	\$815.00	3
Endurance Bed 2.0 Burgundy	7801BY	\$830.00	\$815.00	3
Endurance Bed 2.1 with side storage compartments Black	7802BK	\$1,100.00	\$1,075.00	3
Endurance Bed 2.1 with side storage compartments Slate Blue	7802SB	\$1,100.00	\$1,075.00	3
Endurance Bed 2.1 with side storage compartments Green	7802GN	\$1,100.00	\$1,075.00	3
Endurance Bed 2.1 with side storage compartments Brown	7802BN	\$1,100.00	\$1,075.00	3
Endurance Bed 2.1 with side storage compartments Blue/Gray	7802BG	\$1,100.00	\$1,075.00	3
Endurance Bed 2.1 with side storage compartments Gray	7802GY	\$1,100.00	\$1,075.00	3
Endurance Bed 2.1 with side storage compartments Sand	7802SD	\$1,100.00	\$1,075.00	3
Endurance Bed 2.1 with side storage compartments Burgundy	7802BY	\$1,100.00	\$1,075.00	3
Endurance Bed 2.2 no storage compartments Black	7803BK	\$830.00	\$815.00	3
Endurance Bed 2.2 no storage compartments Slate Blue	7803SB	\$830.00	\$815.00	3
Endurance Bed 2.2 no storage compartments Green	7803GN	\$830.00	\$815.00	3
Endurance Bed 2.2 no storage compartments Brown	7803BN	\$830.00	\$815.00	3
Endurance Bed 2.2 no storage compartments Blue/Gray	7803BG	\$830.00	\$815.00	3
Endurance Bed 2.2 no storage compartments Gray	7803GY	\$830.00	\$815.00	3

Endurance Bed 2.2 no storage compartments Sand	7803SD	\$830.00	\$815.00	3
Endurance Bed 2.2 no storage compartments Burgundy	7803BY	\$830.00	\$815.00	3
Restraint Rings for Endurance Bed and Endurance 2.0 Bed	302003	\$19.50		
Endurance Bed Riser for 2.0 Bed Black	7606BK	\$538.24	\$495.90	8
Endurance Bed Riser for 2.0 Bed Slate Blue	7606SB	\$538.24	\$495.90	8
Endurance Bed Riser for 2.0 Bed Green	7606GN	\$538.24	\$495.90	8
Endurance Bed Riser for 2.0 Bed Brown	7606BN	\$538.24	\$495.90	8
Endurance Bed Riser for 2.0 Bed Blue/Gray	7606BG	\$538.24	\$495.90	8
Endurance Bed Riser for 2.0 Bed Grey	7606GY	\$538.24	\$495.90	8
Endurance Bed Riser for 2.0 Bed Sand	7606SD	\$538.24	\$495.90	8
Endurance Bed Riser for 2.0 Bed Burgundy	7606BY	\$538.24	\$495.90	8
Blue Standard Correctional Mattress 4.5 x 25 x 75 w/integrated pillows	C452575P	\$94.90	\$94.90	1
Blue Standard Correctional Mattress 4.5 x 30 x 75 w/integrated pillows	C453075P	\$122.09	\$122.09	1
Blue Standard Correctional Mattress 4.5 x 35 x 75 w/integrated pillows	C453575P	\$129.35	\$129.35	1
SEG-MAX Correctional Mattress 4.5 x 30 x 75 w/integrated pillows	SEG453075P	\$262.61	\$262.61	1
SEG-MAX Correctional Mattress 4.5 x 35 x 75 w/integrated pillows	SEG453575P	\$269.88	\$269.88	1
See-clear-ity Correctional Mattress 3 x 25 x 75 no pillows	SEEMAT302575	\$140.50	\$140.50	1
Clear Vinyl Correctional Mattress 4.5 x 25 x 75 w/integrated pillow	CLR452575P	\$69.30	\$69.30	1
Clear Vinyl Correctional Mattress 4.5 x 30 x 75 w/integrated pillow	CLR453075P	\$83.16	\$83.16	1
Clear Vinyl Correctional Mattress 4.5 x 35 x 75 w/integrated pillow	CLR453575P	\$97.02	\$97.02	1
Standard Pinnacle 6 x 30 x 75	G603075	\$240.41	\$240.41	1
Standard Pinnacle 6 x 36 x 80	G603680	\$293.80	\$293.80	1
Pinnacle Plus 6 x 36x x 80 Rated for 250lbs +	G603680PLUS	\$300.59	\$300.59	1
Standard Pinnacle 6 x 39 x 80	G603980	\$382.14	\$382.14	1
Seg Max Pinnacle 6 x 30 x 75	SEG603075	\$376.64	\$376.64	1
Seg Max Pinnacle 6 x 36 x 80	SEG603680	\$439.95	\$439.95	1
Seg Max Pinnacle 6 x 39 x 81	SEG603980	\$453.27	\$453.27	1
EZ Gator Suit Suicide Smock	GATORSUIT	\$0.00	\$309.00	1
Endurance NightStand, Black	7602BK	\$220.00	\$196.65	16

Endurance NightStand, Slate Blue	7602SB	\$220.00	\$196.65	16
Endurance NightStand, Green	7602GN	\$220.00	\$196.65	16
Endurance NightStand, Brown	7602BN	\$220.00	\$196.65	16
Endurance NightStand, Blue Grey	7602BG	\$220.00	\$196.65	16
Endurance NightStand, Grey	7602GY	\$220.00	\$196.65	16
Endurance NightStand, Sand	7602SD	\$220.00	\$196.65	16
Endurance NightStand, Burgundy	7602BY	\$220.00	\$196.65	16
Endurance Desk, All plastic, Wall Mount Black	7605BK	\$425.00	\$403.99	6
Endurance Desk, All plastic, Wall Mount Grey	7605GY	\$425.00	\$403.99	6
Endurance Desk, All plastic, Wall Mount Slate Blue	7605SB	\$425.00	\$403.99	6
Endurance Desk, All plastic, Wall Mount Green	7605GN	\$425.00	\$403.99	6
Endurance Desk, All plastic, Wall Mount Brown	7605BN	\$425.00	\$403.99	6
Endurance Desk, All plastic, Wall Mount Blue Grey	7605BG	\$425.00	\$403.99	6
Endurance Desk, All plastic, Wall Mount Sand	7605SD	\$425.00	\$403.99	6
Endurance Desk, All plastic, Wall Mount Burgundy	7605BY	\$425.00	\$403.99	6
Endurance Desk, All plastic, Standing/floor Mount Black	7607BK	\$450.00	\$427.50	6
Endurance Desk, All plastic, Standing/floor Mount Grey	7607GY	\$450.00	\$427.50	6
Endurance Desk, All plastic, Standing/floor Mount Slate Blue	7607SB	\$450.00	\$427.50	6
Endurance Desk, All plastic, Standing/floor Mount Green	7607GN	\$450.00	\$427.50	6
Endurance Desk, All plastic, Standing/floor Mount Brown	7607BN	\$450.00	\$427.50	6
Endurance Desk, All plastic, Standing/floor Mount Blue Grey	7607BG	\$450.00	\$427.50	6
Endurance Desk, All plastic, Standing/floor Mount Sand	7607SD	\$450.00	\$427.50	6
Endurance Desk, All plastic, Standing/floor Mount Burgundy	7607BY	\$450.00	\$427.50	6
Endurance Wall 2 shelf, Black	7604BK	\$200.00	\$175.28	12
Endurance Wall 2 shelf, Grey	7604GY	\$200.00	\$175.28	12
Endurance Wall 2 shelf, Slate Blue	7604SB	\$200.00	\$175.28	12
Endurance Wall 2 shelf, Green	7604GN	\$200.00	\$175.28	12
Endurance Wall 2 shelf, Brown	7604BN	\$200.00	\$175.28	12
Endurance Wall 2 shelf, Blue Grey	7604BG	\$200.00	\$175.28	12

Endurance Wall 2 shelf, Sand	7604SD	\$200.00	\$175.28	12
Endurance Wall 2 shelf, Burgundy	7604BY	\$200.00	\$175.28	12
Endurance 4 shelf, Black	7101BK	\$380.00	\$342.00	8
Endurance 4 shelf, Grey	7101GY	\$380.00	\$342.00	8
Endurance 4 shelf, Slate Blue	7101SB	\$380.00	\$342.00	8
Endurance 4 shelf, Green	7101GN	\$380.00	\$342.00	8
Endurance 4 shelf, Brown	7101BN	\$380.00	\$342.00	8
Endurance 4 shelf, Blue Grey	7101BG	\$380.00	\$342.00	8
Endurance 4 shelf, Sand	7101SD	\$380.00	\$342.00	8
Endurance 4 shelf, Burgundy	7101BY	\$380.00	\$342.00	8
Endurance Chest, Black	7201BK	\$370.00	\$316.35	6
Endurance Chest, Grey	7201GY	\$370.00	\$316.35	6
Endurance Chest, Slate Blue	7201SB	\$370.00	\$316.35	6
Endurance Chest, Green	7201GN	\$370.00	\$316.35	6
Endurance Chest, Brown	7201BN	\$370.00	\$316.35	6
Endurance Chest, Blue Grey	7201BG	\$370.00	\$316.35	6
Endurance Chest, Sand	7201SD	\$370.00	\$316.35	6
Endurance Chest, Burgundy	7201BY	\$370.00	\$316.35	6
Endurance Stool, Black	7901BK	\$130.00	\$109.01	30
Endurance Stool, Grey	7901GY	\$130.00	\$109.01	30
Endurance Stool, Slate Blue	7901SB	\$130.00	\$109.01	30
Endurance Stool, Green	7901GN	\$130.00	\$109.01	30
Endurance Stool, Brown	7901BG	\$130.00	\$109.01	30
Endurance Stool, Blue Grey	7901BN	\$130.00	\$109.01	30
Endurance Stool, Sand	7901SD	\$130.00	\$109.01	30
Endurance Stool, Burgundy	7901BY	\$130.00	\$109.01	30
Clear Visitation Table 40" Round	CLR40	\$170.74	\$850.73	10
Endurance Table 42" Round X-Base Flame Retardant Black	66749BK	\$520.00	\$470.25	4
Endurance Table 42" Round X-Base Flame Retardant Blue Grey	66749BG	\$520.00	\$470.25	4
Endurance Table 42" Round X-Base Flame Retardant Green	66749GN	\$520.00	\$470.25	4
Endurance Table 42" Round X-Base Flame Retardant Grey	66749GY	\$520.00	\$470.25	4
Endurance Table 42" Round X-Base Flame Retardant Slate Blue	66749SB	\$520.00	\$470.25	4

Endurance Table 42' Round X-Base Flame Retardant Sand	66749SD	\$520.00	\$470.25	4
Endurance Table 42' Round X-Base Flame Retardant Brown	66749BN	\$520.00	\$470.25	4
Endurance Table 42' Round X-Base Flame Retardant Burgundy	66749BY	\$520.00	\$470.25	4
Endurance Table 42" Round X-Base Flame Retardant Brown Game Top	66749BNGT	\$580.00	\$534.38	4
Endurance Table 42" Round X-Base Flame Retardant Slate Blue Game Top	66749SBGT	\$580.00	\$534.38	4
Endurance Table 42" Square X-Base Flame Retardant Black	66750BK	\$550.00	\$500.00	4
Endurance Table 42" Square X-Base Flame Retardant Blue Grey	66750BG	\$550.00	\$500.00	4
Endurance Table 42" Square X-Base Flame Retardant Green	66750GN	\$550.00	\$500.00	4
Endurance Table 42" Square X-Base Flame Retardant Grey	66750GY	\$550.00	\$500.00	4
Endurance Table 42' Square X-Base Flame Retardant Slate Blue	66750SB	\$550.00	\$500.00	4
Endurance Table 42" Square X-Base Flame Retardant Sand	66750SD	\$550.00	\$500.00	4
Endurance Table 42" Square X-Base Flame Retardant Burgundy	66750BY	\$550.00	\$500.00	4
Endurance Table 42' Square X-Base Flame Retardant Brown	66750BN	\$550.00	\$500.00	4
Endurance Table 42" Square X-Base Flame Retardant Brown Game Top	66750BNGT	\$600.00	\$575.00	4
Endurance Table 42" Square X-Base Flame Retardant Slate Blue Game Top	66750SBGT	\$600.00	\$575.00	4
Endurance Table 48" Round X-Base Flame Retardant Black	66751BK	\$615.00	\$584.27	6
Endurance Table 48" Round X-Base Flame Retardant Blue Grey	66751BG	\$615.00	\$584.27	6
Endurance Table 48" Round X-Base Flame Retardant Green	66751GN	\$615.00	\$584.27	6
Endurance Table 48" Round X-Base Flame Retardant Grey	66751GY	\$615.00	\$584.27	6
Endurance Table 48' Round X-Base Flame Retardant Slate Blue	66751SB	\$615.00	\$584.27	6
Endurance Table 48' Round X-Base Flame Retardant Sand	66751SD	\$615.00	\$584.27	6
Endurance Table 48' Round X-Base Flame Retardant Brown	66751BN	\$615.00	\$584.27	6
Endurance Table 48' Round X-Base Flame Retardant Burgundy	66751BY	\$615.00	\$584.27	6
Endurance Table 48" Round X-Base Flame Retardant Brown Game Top	66751BNGT	\$700.00	\$641.25	6
Endurance Table 48" Round X-Base Flame Retardant Slate Blue Game Top	66751SBGT	\$700.00	\$641.25	6

DESCRIPTION	PART NUMBER	Qty Per Skid	(1) Table Unit Price	(2) Table Unit Price	(3) Table Unit Price
Picnic Tables					
Polly Tuff 6' Easy Access Picnic Table Overall Dimensions: 72"W x 30-1/2"H x 60-13/16"D Base: Black, Top: Brown	PTEA6	3	\$ 1,879.80	\$ 1,742.80	\$ 1,696.46
Polly Tuff 8' Easy Access Picnic Table Overall Dimensions: 96"W x 30-1/2"H x 60-13/16"D Base: Black, Top: Brown	PTEA8	3	\$ 2,199.36	\$ 2,067.36	\$ 1,988.36

- 1). One-piece leg frames are solid, molded recycled plastic; seats are heavy-duty 2" x 10" recycled plastic lumber.
- 2). Prices above include delivery to any Department of Corrections (DOC) location in the State of Michigan. Picnic Tables Pricing Matrix above shows Unit Price for 1, 2, and 3 tables; best price is achieved by purchasing in quantities of 3 (3 Tables are on One Skid/Pallet).
- 3). Prices quoted are with lift gate available for use upon delivery to facility. No additional charges apply if facility needs a lift gate for each order, however advance notice must be given.
- 4). Some assembly required.
- 5). Current Lead Time: 21 weeks.

Added Items:

- 1) **ENDURANCE TABLE 42" SQUARE X BASE** (Contractor Item numbers below): Game top: Contract price- \$575 ea. for full skid quantity (4) or more OR \$600 ea. Plain top: Contract price \$500 ea. for full skid quantity (4) or more OR \$550 ea.

PLAIN TOP	GAME TOP	SIZE	COLOR
66750AQ	66750AQGT	42" Square	Aqua
66750BK	66750BKGT	42" Square	Black
66750BG	66750BGGT	42" Square	Blue Gray
66750BN	66750BNGT	42" Square	Brown
66750BY	66750BYGT	42" Square	Burgundy
66750GY	66750GYGT	42" Square	Gray
66750GN	66750GNGT	42" Square	Green
66750IG	66750IGGT	42" Square	Indigo
66750MB	66750MBGT	42" Square	Midnight Blue
66750SD	66750SDGT	42" Square	Sand
66750SB	66750SBGT	42" Square	Slate Blue
66750SG	66750SGGT	42" Square	Stone Gray

- 2) **710GYCS- TRASH CAN GRAY 10QT FR (6 PK):**
Contract price- \$105.17 ea./pk for full skid quantity (20 pk) OR \$130 ea./pk
- 3) **7901BK- ENDURANCE FLOOR STOOL BLACK 13X13X16:**
Contract price- \$109.01 ea. for full skid quantity (30) OR \$130 ea.
- 4) **25200FR-Container 25 Gal Blue Gray FR:**
Contract price- \$155.00

Discontinued Items:

- 1) See-clear-ity Correctional Mattress 3 x 25 x 75 no pillows ****DISCONTINUED****
- 2) EZ Gator Suit Suicide Smock ****DISCONTINUED****
- 3) Clear Visitation Table 40" Round ****DISCONTINUED****

STATE OF MICHIGAN

Contract No. 200000000373
Statewide – Anti-Ligature Furnishing Services

SCHEDULE C PRODUCT SPECIFICATIONS

Michigan Department of Health and Human Services (MDHHS) Hospitals:

1. Caro Center
 - a. 2000 Chambers Road, Caro, MI 48723
2. Center for Forensic Psychiatry (CFP)
 - a. 8303 Platt Road, Saline, MI 48176
3. Hawthorn Center
 - a. 18471 Haggerty Road, Northville, MI 48167
4. Kalamazoo Psychiatric Hospital (KPH)
 - a. 1312 Oakland Drive, Kalamazoo, MI 49008
5. Walter Reuther Psychiatric Hospital (WRPH)
 - a. 30901 Palmer Road, Westland, MI 48186

Additional MDHHS Facility:

1. Juvenile Justice Residential (JJB) Facility
 - a. Bay pines Center
 - i. 2425 N 30th Street, Escanaba, MI 49829
 - b. Shawono Center
 - i. 10 N Howes Lake Road, Grayling, MI 49738

BJJ Centers:

- Bay Pines Center
- Shawono Center

Please note the following items are a general list of items currently utilized, items listed are an indicator of future need and are in no way a guarantee of items to be purchased by the State in the future.

In Section 1.1 Product Specifications, of Schedule A – Statement of Work, please confirm that items offered by your Organization will meet the minimum requirements show below.

Special Notes:

1. Classroom furnishings must be youth appropriate for high security residential living.
2. Classroom furnishings must allow for arrangement around the perimeter of the room, to allow for the teachers' station to have no youth desk to their back.
3. It is preferred that desks/workstations be adjustable and are movable with locking wheels If applicable.
4. Desks/workstations must be made of materials that not breakable, that can withstand hitting, kicking and other means of force, or easily throw.
5. Desks/workstations cannot have components, pieces or parts that can be removed easily, taken or broken off.
6. Each desk/workstation should have some a partition/divider on the underneath to prevent physical contact from another desk/workstation.
7. The following products must be new, fire-retardant polyethylene; the following are anticipated items for purchase:
 - a. Classroom – Seating, Chairs
 - b. Classroom Seating, Desks
 - c. Classroom Teachers Desk



STATE OF MICHIGAN
CENTRAL PROCUREMENT SERVICES
 Department of Technology, Management, and Budget
 525 W. ALLEGAN ST., LANSING, MICHIGAN 48913
 P.O. BOX 30026 LANSING, MICHIGAN 48909

CONTRACT CHANGE NOTICE

Change Notice Number 2
 to
 Contract Number 20000000373

CONTRACTOR	CORRECTIONAL TECHNOLOGIES, INC.
	7530 Plaza Court
	Willowbrook, IL 60527
	Steve Csuk
	630-455-0811
	steve@cortechusa.com
	CV0017523

STATE	Program Manager	Various	SW
	Contract Administrator	Mary Ostrowski	DTMB
		(517) 249-0438	
		ostrowskim@michigan.gov	

CONTRACT SUMMARY

ANTI-LIGATURE FURNISHING SERVICES - STATEWIDE			
INITIAL EFFECTIVE DATE	INITIAL EXPIRATION DATE	INITIAL AVAILABLE OPTIONS	EXPIRATION DATE BEFORE
February 1, 2020	January 31, 2025	5 - 1 Year	January 31, 2025
PAYMENT TERMS		DELIVERY TIMEFRAME	
1NET10; 1½ NET15; NET 45		N/A	
ALTERNATE PAYMENT OPTIONS			EXTENDED PURCHASING
<input type="checkbox"/> P-Card <input type="checkbox"/> PRC <input type="checkbox"/> Other			<input checked="" type="checkbox"/> Yes <input type="checkbox"/> No

MINIMUM DELIVERY REQUIREMENTS

N/A

DESCRIPTION OF CHANGE NOTICE

OPTION	LENGTH OF OPTION	EXTENSION	LENGTH OF EXTENSION	REVISED EXP. DATE
<input type="checkbox"/>		<input type="checkbox"/>		N/A
CURRENT VALUE	VALUE OF CHANGE NOTICE	ESTIMATED AGGREGATE CONTRACT VALUE		
\$2,245,000.00	\$0.00	\$2,245,000.00		

DESCRIPTION

Effective August 10, 2021, the following updates are made to State and Contractor Staff:

Contractor Staff update:
 -Steve Csuk; Steve@cortechusa.com; (630) 455-0811 is replacing Jason Fisher in all Sections noted below:
 - Contract Cover page
 - Standard Contract Terms Section 2. Notices, and Section 3 Contract Administrator
 - Schedule A, Section 2.1, 2.4, and 3. as Contractor Representative

State Staff update:
 -Mike Roesner; roesnerm@michigan.gov; (517) 284-0183 is replacing Jennifer Frank as MDHHS State Program Manager and in all Sections noted below:
 - Contract Cover page
 - Standard Contract Terms Section 4. Program Manager

-MDOC Program Manager Arnold Vandemark is replaced by the following 2 Program Managers, noted on the Contract Cover Page and Standard Contract Terms Section 4. Program Manager:

-South - Eames Groenleer; GroenleerE@michigan.gov; (517) 780-6076

-North - George Sevarns; SevarnsG@michigan.gov; (906) 322-8499

All other terms, conditions, specifications and pricing remain the same. Per Contractor and Agency agreement and Central Procurement Services approval.

**Program Managers
for
Multi-Agency and Statewide Contracts**

AGENCY	NAME	PHONE	EMAIL
MDHHS	Michael Roesner	517-284-0183	roesnerm@michigan.gov
MDOC	Eames E. Groenleer	517-780-6076	GroenleerE@michigan.gov
MDOC	George B. Sevarns	906-293-0005	SevarnsG@michigan.gov



STATE OF MICHIGAN
CENTRAL PROCUREMENT SERVICES
 Department of Technology, Management, and Budget
 525 W. ALLEGAN ST., LANSING, MICHIGAN 48913
 P.O. BOX 30026 LANSING, MICHIGAN 48909

CONTRACT CHANGE NOTICE

Change Notice Number 1
 to
 Contract Number 200000000373

CONTRACTOR	CORRECTIONAL TECHNOLOGIES, INC.
	7530 Plaza Court
	Willowbrook, IL 60527
	Jason Fisher
	630-445-0811
	jason@cortechusa.com
	CV0017523

STATE	Program Manager	Various	SW
	Contract Administrator	Sarah Walter	DTMB
		517-256-4237	
		walters6@michigan.gov	

CONTRACT SUMMARY

ANTI-LIGATURE FURNISHING SERVICES - STATEWIDE

INITIAL EFFECTIVE DATE	INITIAL EXPIRATION DATE	INITIAL AVAILABLE OPTIONS	EXPIRATION DATE BEFORE
February 1, 2020	January 31, 2025	5 - 1 Year	January 31, 2025
PAYMENT TERMS		DELIVERY TIMEFRAME	
1NET10; 1½ NET15; Net 45		N/A	
ALTERNATE PAYMENT OPTIONS			EXTENDED PURCHASING
<input type="checkbox"/> P-Card <input type="checkbox"/> PRC <input type="checkbox"/> Other			<input checked="" type="checkbox"/> Yes <input type="checkbox"/> No

MINIMUM DELIVERY REQUIREMENTS

N/A

DESCRIPTION OF CHANGE NOTICE

OPTION	LENGTH OF OPTION	EXTENSION	LENGTH OF EXTENSION	REVISED EXP. DATE
<input type="checkbox"/>	N/A	<input type="checkbox"/>	N/A	N/A
CURRENT VALUE	VALUE OF CHANGE NOTICE	ESTIMATED AGGREGATE CONTRACT VALUE		
\$2,000,000.00	\$245,000.00	\$2,245,000.00		

DESCRIPTION

Effective March 27, 2020 please note the following:

- This Contract is hereby increased by \$245,000.00 for the Michigan Department of Corrections (MDOC) use;
- The following Program Manager is hereby added for MDOC: Arnold Vande Mark; Phone: 517-335-2083; Email: VandeMarkA@michigan.gov.

All other term, conditions, specifications and pricing remain the same, per Contractor and Agency agreement and DTMB Central Procurement Services approval.



STATE OF MICHIGAN PROCUREMENT
 Department of Technology Management and Budget
 525 W. Allegan 1st Floor, Lansing, MI 48913
 P.O. BOX 30026 Lansing, MI 48909

NOTICE OF CONTRACT

NOTICE OF CONTRACT NO. 200000000373
 between
 THE STATE OF MICHIGAN
 and

CONTRACTOR	Corectional Technologies Inc.
	7530 Plaza Court
	Willowbrook, IL 60527
	Jason Fisher
	630-445-0811
	jason@cortechusa.com
	CV0017523

STATE	Program Manager	Jennifer Frank	DHHS
		517-241-6563	
		FrankJ4@michigan.gov	
	Contract Administrator	Sarah Walter	DTMB
517-256-4237			
WalterS6@michigan.gov			

CONTRACT SUMMARY			
DESCRIPTION: Anti-Ligature Furnishing Services – Statewide			
INITIAL EFFECTIVE DATE	INITIAL EXPIRATION DATE	INITIAL AVAILABLE OPTIONS	EXPIRATION DATE BEFORE CHANGE(S) NOTED BELOW
February 1, 2020	January 31, 2025	5, 1-year	N/A
PAYMENT TERMS		DELIVERY TIMEFRAME	
1NET10; 1½ NET15; Net 45		N/A	
ALTERNATE PAYMENT OPTIONS			EXTENDED PURCHASING
<input type="checkbox"/> P-card <input type="checkbox"/> Payment Request (PRC) <input type="checkbox"/> Other			<input checked="" type="checkbox"/> Yes <input type="checkbox"/> No
MINIMUM DELIVERY REQUIREMENTS			
N/A			
MISCELLANEOUS INFORMATION			
THIS IS NOT AN ORDER. This Contract Agreement is awarded on the basis of our inquiring RFP NO. 190000003175. Orders for delivery will be issued directly by Departments through the issuance of a Delivery Order Form.			
ESTIMATED CONTRACT VALUE AT TIME OF EXECUTION			\$2,000,000.00

FOR THE CONTRACTOR:

Company Name

Authorized Agent Signature

Authorized Agent (Print or Type)

Date

FOR THE STATE:

Signature

Name & Title

Agency

Date

STATE OF MICHIGAN

Contract No. 200000000373
Statewide – Anti-Ligature Furnishing Services

Table of Contents

1. Standard Contract Terms	Pages 4 – 13
2. Federal Provisions Addendum	Pages 14 – 16
3. Byrd Anti-Lobbying Certification	Page 16
4. Schedules:	
Schedule A – Statement of Work	Pages 17 – 24
Schedule B – Pricing	Pages 25 – 35
Schedule C – Product Specifications	Pages 36 – 38
5. Vendor Products:	
Schedule D – Vendor Products – Endurance	Pages 39 – 71
Schedule E – Derby SEG-MAX Pinnacle Mattress	Pages 72 – 76



STATE OF MICHIGAN

STANDARD CONTRACT TERMS

This STANDARD CONTRACT (“**Contract**”) is agreed to between the State of Michigan (the “**State**”) and Correctional Technologies Inc. (dba CortechUSA) (“**Contractor**”), an Illinois Corporation. This Contract is effective on February 1, 2020 (“**Effective Date**”), and unless terminated, expires on January 31, 2025.

This Contract may be renewed for up to 5, additional 1-year period(s). Renewal is at the sole discretion of the State and will automatically extend the Term of this Contract. The State will document its exercise of renewal options via Change Notice.

The parties agree as follows:

- 1. Duties of Contractor.** Contractor must perform the services and provide the deliverables described in **Schedule A – Statement of Work** (the “**Contract Activities**”). An obligation to provide delivery of any commodity is considered a service and is a Contract Activity.

Contractor must furnish all labor, equipment, materials, and supplies necessary for the performance of the Contract Activities, and meet operational standards, unless otherwise specified in Schedule A.

Contractor must: (a) perform the Contract Activities in a timely, professional, safe, and workmanlike manner consistent with standards in the trade, profession, or industry; (b) meet or exceed the performance and operational standards, and specifications of the Contract; (c) provide all Contract Activities in good quality, with no material defects; (d) not interfere with the State’s operations; (e) obtain and maintain all necessary licenses, permits or other authorizations necessary for the performance of the Contract; (f) cooperate with the State, including the State’s quality assurance personnel, and any third party to achieve the objectives of the Contract; (g) return to the State any State-furnished equipment or other resources in the same condition as when provided when no longer required for the Contract; (h) not make any media releases without prior written authorization from the State; (i) assign to the State any claims resulting from state or federal antitrust violations to the extent that those violations concern materials or services supplied by third parties toward fulfillment of the Contract; (j) comply with all State physical and IT security policies and standards which will be made available upon request; and (k) provide the State priority in performance of the Contract except as mandated by federal disaster response requirements. Any breach under this paragraph is considered a material breach.

Contractor must also be clearly identifiable while on State property by wearing identification issued by the State, and clearly identify themselves whenever making contact with the State.

- 2. Notices.** All notices and other communications required or permitted under this Contract must be in writing and will be considered given and received: (a) when verified by written receipt if sent by courier; (b) when actually received if sent by mail without verification of receipt; or (c) when verified by automated receipt or electronic logs if sent by facsimile or email.

If to State:	If to Contractor:
Sarah Walter 525 W. Allegan St. Lansing, Michigan, 48819 WalterS6@michigan.gov 517-256-4237	Jason Fisher 7530 Plaza Court Willowbrook, Illinois 60527 Jason@cortechusa.com 630-455-0811

3. **Contract Administrator.** The Contract Administrator for each party is the only person authorized to modify any terms of this Contract, and approve and execute any change under this Contract (each a “**Contract Administrator**”):

State:	Contractor:
Sarah Walter 525 W. Allegan St. Lansing, Michigan, 48819 WalterS6@michigan.gov 517-256-4237	Jason Fisher 7530 Plaza Court Willowbrook, Illinois 60527 Jason@cortechusa.com 630-445-0811

4. **Program Manager.** The Program Manager for each party will monitor and coordinate the day-to-day activities of the Contract (each a “**Program Manager**”):

State:	Contractor:
Jennifer Frank 235 S. Grand Ave. Lansing, Michigan 48933 FrankJ4@michigan.gov 517-241-6563	Janie Jennings 7530 Plaza Court Willowbrook, Illinois 60527 Jason@cortechusa.com 630-445-0811

5. **Performance Guarantee.** Contractor must at all times have financial resources sufficient, in the opinion of the State, to ensure performance of the Contract and must provide proof upon request. The State may require a performance bond (as specified in Schedule A) if, in the opinion of the State, it will ensure performance of the Contract.
6. **Insurance Requirements.** Contractor must maintain the insurances identified below and is responsible for all deductibles. All required insurance must: (a) protect the State from claims that may arise out of, are alleged to arise out of, or result from Contractor's or a subcontractor's performance; (b) be primary and non-contributing to any comparable liability insurance (including self-insurance) carried by the State; and (c) be provided by a company with an A.M. Best rating of "A-" or better, and a financial size of VII or better.

Required Limits	Additional Requirements
Commercial General Liability Insurance	
<u>Minimum Limits:</u> \$1,000,000 Each Occurrence Limit \$1,000,000 Personal & Advertising Injury Limit \$2,000,000 General Aggregate Limit \$2,000,000 Products/Completed Operations <u>Deductible Maximum:</u> \$50,000 Each Occurrence	Contractor must have their policy endorsed to add “the State of Michigan, its departments, divisions, agencies, offices, commissions, officers, employees, and agents” as additional insureds using endorsement CG 20 10 11 85, or both CG 2010 07 04 and CG 2037 07 04. Coverage must not have exclusions or limitations related to sexual abuse and molestation liability.
Umbrella or Excess Liability Insurance	
<u>Minimum Limits:</u> \$5,000,000 General Aggregate	Contractor must have their policy follow form.

Automobile Liability Insurance	
<u>Minimum Limits:</u> \$1,000,000 Per Accident	Contractor must have their policy: (1) endorsed to add "the State of Michigan, its departments, divisions, agencies, offices, commissions, officers, employees, and agents" as additional insureds; and (2) include Hired and Non-Owned Automobile coverage.
Workers' Compensation Insurance	
<u>Minimum Limits:</u> Coverage according to applicable laws governing work activities.	Waiver of subrogation, except where waiver is prohibited by law.
Employers Liability Insurance	
<u>Minimum Limits:</u> \$500,000 Each Accident \$500,000 Each Employee by Disease \$500,000 Aggregate Disease.	

If any of the required policies provide **claims-made** coverage, the Contractor must: (a) provide coverage with a retroactive date before the effective date of the contract or the beginning of Contract Activities; (b) maintain coverage and provide evidence of coverage for at least three (3) years after completion of the Contract Activities; and (c) if coverage is cancelled or not renewed, and not replaced with another claims-made policy form with a retroactive date prior to the contract effective date, Contractor must purchase extended reporting coverage for a minimum of three (3) years after completion of work.

Contractor must: (a) provide insurance certificates to the Contract Administrator, containing the agreement or delivery order number, at Contract formation and within 20 calendar days of the expiration date of the applicable policies; (b) require that subcontractors maintain the required insurances contained in this Section; (c) notify the Contract Administrator within 5 business days if any insurance is cancelled; and (d) waive all rights against the State for damages covered by insurance. Failure to maintain the required insurance does not limit this waiver.

This Section is not intended to and is not to be construed in any manner as waiving, restricting or limiting the liability of either party for any obligations under this Contract (including any provisions hereof requiring Contractor to indemnify, defend and hold harmless the State).

- Administrative Fee and Reporting.** Contractor must pay an administrative fee of 1% on all payments made to Contractor under the Contract including transactions with the State (including its departments, divisions, agencies, offices, and commissions), MiDEAL members, and other states (including governmental subdivisions and authorized entities). Administrative fee payments must be made by check payable to the State of Michigan and mailed to:

Department of Technology, Management and Budget
 Cashiering
 P.O. Box 30681
 Lansing, MI 48909

Contractor must submit an itemized purchasing activity report, which includes at a minimum, the name of the purchasing entity and the total dollar volume in sales. Reports should be mailed to MiDeal@michigan.gov.

The administrative fee and purchasing activity report are due within 30 calendar days from the last day of each calendar quarter.

- Extended Purchasing Program.** This contract is extended to MiDEAL members. MiDEAL members include local units of government, school districts, universities, community colleges, and nonprofit hospitals. A current list of MiDEAL members is available at www.michigan.gov/mideal.

Upon written agreement between the State and Contractor, this contract may also be extended to: (a) other states (including governmental subdivisions and authorized entities) and (b) State of Michigan employees.

If extended, Contractor must supply all Contract Activities at the established Contract prices and terms. The State reserves the right to impose an administrative fee and negotiate additional discounts based on any increased volume generated by such extensions.

Contractor must submit invoices to, and receive payment from, extended purchasing program members on a direct and individual basis.

9. **Independent Contractor.** Contractor is an independent contractor and assumes all rights, obligations and liabilities set forth in this Contract. Contractor, its employees, and agents will not be considered employees of the State. No partnership or joint venture relationship is created by virtue of this Contract. Contractor, and not the State, is responsible for the payment of wages, benefits and taxes of Contractor's employees and any subcontractors. Prior performance does not modify Contractor's status as an independent contractor.
10. **Subcontracting.** Contractor may not delegate any of its obligations under the Contract without the prior written approval of the State. Contractor must notify the State at least 90 calendar days before the proposed delegation and provide the State any information it requests to determine whether the delegation is in its best interest. If approved, Contractor must: (a) be the sole point of contact regarding all contractual matters, including payment and charges for all Contract Activities; (b) make all payments to the subcontractor; and (c) incorporate the terms and conditions contained in this Contract in any subcontract with a subcontractor. Contractor remains responsible for the completion of the Contract Activities, compliance with the terms of this Contract, and the acts and omissions of the subcontractor. The State, in its sole discretion, may require the replacement of any subcontractor.
11. **Staffing.** The State's Contract Administrator may require Contractor to remove or reassign personnel by providing a notice to Contractor.
12. **Background Checks.** Pursuant to Michigan law, all agencies subject to IRS Pub. 1075 are required to ask the Michigan State Police to perform fingerprint background checks on all employees, including Contractor and Subcontractor employees, who may have access to any database of information maintained by the federal government that contains confidential or personal information, including, but not limited to, federal tax information. Further, pursuant to Michigan law, any agency described above is prohibited from providing Contractors or Subcontractors with the result of such background check. For more information, please see Michigan Public Act 427 of 2018. Upon request, Contractor must perform background checks on all employees and subcontractors and its employees prior to their assignment. The scope is at the discretion of the State and documentation must be provided as requested. Contractor is responsible for all costs associated with the requested background checks. The State, in its sole discretion, may also perform background checks.
13. **Assignment.** Contractor may not assign this Contract to any other party without the prior approval of the State. Upon notice to Contractor, the State, in its sole discretion, may assign in whole or in part, its rights or responsibilities under this Contract to any other party. If the State determines that a novation of the Contract to a third party is necessary, Contractor will agree to the novation and provide all necessary documentation and signatures.
14. **Change of Control.** Contractor will notify within 30 days of any public announcement or otherwise once legally permitted to do so, the State of a change in Contractor's organizational structure or ownership. For purposes of this Contract, a change in control means any of the following: (a) a sale of more than 50% of Contractor's stock; (b) a sale of substantially all of Contractor's assets; (c) a change in a majority of Contractor's board members; (d) consummation of a merger or consolidation of Contractor with any other entity; (e) a change in ownership through a transaction or series of transactions; (f) or the board (or the stockholders) approves a plan of complete liquidation. A change of control does not include any consolidation or merger effected exclusively to change the domicile of Contractor, or any transaction or series of transactions principally for bona fide equity financing purposes.

In the event of a change of control, Contractor must require the successor to assume this Contract and all of its obligations under this Contract.

15. **Ordering.** Contractor is not authorized to begin performance until receipt of authorization as identified in Schedule A.

16. **Acceptance.** Contract Activities are subject to inspection and testing by the State within 30 calendar days of the State's receipt of them ("**State Review Period**"), unless otherwise provided in Schedule A. If the Contract Activities are not fully accepted by the State, the State will notify Contractor by the end of the State Review Period that either: (a) the Contract Activities are accepted but noted deficiencies must be corrected; or (b) the Contract Activities are rejected. If the State finds material deficiencies, it may: (i) reject the Contract Activities without performing any further inspections; (ii) demand performance at no additional cost; or (iii) terminate this Contract in accordance with Section 23, Termination for Cause.

Within 10 business days from the date of Contractor's receipt of notification of acceptance with deficiencies or rejection of any Contract Activities, Contractor must cure, at no additional cost, the deficiency and deliver unequivocally acceptable Contract Activities to the State. If acceptance with deficiencies or rejection of the Contract Activities impacts the content or delivery of other non-completed Contract Activities, the parties' respective Program Managers must determine an agreed to number of days for re-submission that minimizes the overall impact to the Contract. However, nothing herein affects, alters, or relieves Contractor of its obligations to correct deficiencies in accordance with the time response standards set forth in this Contract.

If Contractor is unable or refuses to correct the deficiency within the time response standards set forth in this Contract, the State may cancel the order in whole or in part. The State, or a third party identified by the State, may perform the Contract Activities and recover the difference between the cost to cure and the Contract price plus an additional 10% administrative fee.

17. **Delivery.** Contractor must deliver all Contract Activities F.O.B. destination, within the State premises with transportation and handling charges paid by Contractor, unless otherwise specified in Schedule A. All containers and packaging become the State's exclusive property upon acceptance.
18. **Risk of Loss and Title.** Until final acceptance, title and risk of loss or damage to Contract Activities remains with Contractor. Contractor is responsible for filing, processing, and collecting all damage claims. The State will record and report to Contractor any evidence of visible damage. If the State rejects the Contract Activities, Contractor must remove them from the premises within 10 calendar days after notification of rejection. The risk of loss of rejected or non-conforming Contract Activities remains with Contractor. Rejected Contract Activities not removed by Contractor within 10 calendar days will be deemed abandoned by Contractor, and the State will have the right to dispose of it as its own property. Contractor must reimburse the State for costs and expenses incurred in storing or effecting removal or disposition of rejected Contract Activities.
19. **Warranty Period.** The warranty period, if applicable, for Contract Activities is a fixed period commencing on the date specified in Schedule A. If the Contract Activities do not function as warranted during the warranty period, the State may return such non-conforming Contract Activities to the Contractor for a full refund.
20. **Terms of Payment.** Invoices must conform to the requirements communicated from time-to-time by the State. All undisputed amounts are payable within 45 days of the State's receipt. Contractor may only charge for Contract Activities performed as specified in Schedule A. Invoices must include an itemized statement of all charges. The State is exempt from State sales tax for direct purchases and may be exempt from federal excise tax, if Services purchased under this Agreement are for the State's exclusive use. All prices are exclusive of taxes, and Contractor is responsible for all sales, use and excise taxes, and any other similar taxes, duties and charges of any kind imposed by any federal, state, or local governmental entity on any amounts payable by the State under this Contract.

The State has the right to withhold payment of any disputed amounts until the parties agree as to the validity of the disputed amount. The State will notify Contractor of any dispute within a reasonable time. Payment by the State will not constitute a waiver of any rights as to Contractor's continuing obligations, including claims for deficiencies or substandard Contract Activities. Contractor's acceptance of final payment by the State constitutes a waiver of all claims by Contractor against the State for payment under this Contract, other than those claims previously filed in writing on a timely basis and still disputed.

The State will only disburse payments under this Contract through Electronic Funds Transfer (EFT). Contractor must register with the State at <http://www.michigan.gov/SIGMAVSS> to receive electronic fund transfer payments. If Contractor does not register, the State is not liable for failure to provide payment. Without prejudice to any other right or remedy it may have, the State reserves the right to set off at any time any amount then due and owing to it by Contractor against any amount payable by the State to Contractor under this Contract.

21. **Liquidated Damages.** Liquidated damages, if applicable, will be assessed as described in Schedule A.

- 22. Stop Work Order.** The State may suspend any or all activities under the Contract at any time. The State will provide Contractor a written stop work order detailing the suspension. Contractor must comply with the stop work order upon receipt. Within 90 calendar days, or any longer period agreed to by Contractor, the State will either: (a) issue a notice authorizing Contractor to resume work, or (b) terminate the Contract or delivery order. The State will not pay for Contract Activities, Contractor's lost profits, or any additional compensation during a stop work period.
- 23. Termination for Cause.** The State may terminate this Contract for cause, in whole or in part, if Contractor, as determined by the State: (a) endangers the value, integrity, or security of any location, data, or personnel; (b) becomes insolvent, petitions for bankruptcy court proceedings, or has an involuntary bankruptcy proceeding filed against it by any creditor; (c) engages in any conduct that may expose the State to liability; (d) breaches any of its material duties or obligations; or (e) fails to cure a breach within the time stated in a notice of breach. Any reference to specific breaches being material breaches within this Contract will not be construed to mean that other breaches are not material.

If the State terminates this Contract under this Section, the State will issue a termination notice specifying whether Contractor must: (a) cease performance immediately, or (b) continue to perform for a specified period. If it is later determined that Contractor was not in breach of the Contract, the termination will be deemed to have been a Termination for Convenience, effective as of the same date, and the rights and obligations of the parties will be limited to those provided in Section 24, Termination for Convenience.

The State will only pay for amounts due to Contractor for Contract Activities accepted by the State on or before the date of termination, subject to the State's right to set off any amounts owed by the Contractor for the State's reasonable costs in terminating this Contract. The Contractor must pay all reasonable costs incurred by the State in terminating this Contract for cause, including administrative costs, attorneys' fees, court costs, transition costs, and any costs the State incurs to procure the Contract Activities from other sources.

- 24. Termination for Convenience.** The State may immediately terminate this Contract in whole or in part without penalty and for any reason, including but not limited to, appropriation or budget shortfalls. The termination notice will specify whether Contractor must: (a) cease performance of the Contract Activities immediately, or (b) continue to perform the Contract Activities in accordance with Section 25, Transition Responsibilities. If the State terminates this Contract for convenience, the State will pay all reasonable costs, as determined by the State, for State approved Transition Responsibilities.
- 25. Transition Responsibilities.** Upon termination or expiration of this Contract for any reason, Contractor must, for a period of time specified by the State (not to exceed 90 calendar days), provide all reasonable transition assistance requested by the State, to allow for the expired or terminated portion of the Contract Activities to continue without interruption or adverse effect, and to facilitate the orderly transfer of such Contract Activities to the State or its designees. Such transition assistance may include, but is not limited to: (a) continuing to perform the Contract Activities at the established Contract rates; (b) taking all reasonable and necessary measures to transition performance of the work, including all applicable Contract Activities, training, equipment, software, leases, reports and other documentation, to the State or the State's designee; (c) taking all necessary and appropriate steps, or such other action as the State may direct, to preserve, maintain, protect, or return to the State all materials, data, property, and confidential information provided directly or indirectly to Contractor by any entity, agent, vendor, or employee of the State; (d) transferring title in and delivering to the State, at the State's discretion, all completed or partially completed deliverables prepared under this Contract as of the Contract termination date; and (e) preparing an accurate accounting from which the State and Contractor may reconcile all outstanding accounts (collectively, "**Transition Responsibilities**"). This Contract will automatically be extended through the end of the transition period.
- 26. General Indemnification.** Contractor must defend, indemnify and hold the State, its departments, divisions, agencies, offices, commissions, officers, and employees harmless, without limitation, from and against any and all actions, claims, losses, liabilities, damages, costs, attorney fees, and expenses (including those required to establish the right to indemnification), arising out of or relating to: (a) any breach by Contractor (or any of Contractor's employees, agents, subcontractors, or by anyone else for whose acts any of them may be liable) of any of the promises, agreements, representations, warranties, or insurance requirements contained in this Contract; (b) any infringement, misappropriation, or other violation of any intellectual property right or other right of any third party; (c) any bodily injury, death, or damage to real or tangible personal property occurring wholly or in part due to action or inaction by Contractor (or any of Contractor's employees, agents, subcontractors, or by anyone else for whose acts any of them may be liable); and (d) any acts or omissions of Contractor (or any of Contractor's employees, agents, subcontractors, or by anyone else for whose acts any of them may be liable).

The State will notify Contractor in writing if indemnification is sought; however, failure to do so will not relieve Contractor, except to the extent that Contractor is materially prejudiced. Contractor must, to the satisfaction of the State, demonstrate its financial ability to carry out these obligations.

The State is entitled to: (i) regular updates on proceeding status; (ii) participate in the defense of the proceeding; (iii) employ its own counsel; and to (iv) retain control of the defense if the State deems necessary. Contractor will not, without the State's written consent (not to be unreasonably withheld), settle, compromise, or consent to the entry of any judgment in or otherwise seek to terminate any claim, action, or proceeding. To the extent that any State employee, official, or law may be involved or challenged, the State may, at its own expense, control the defense of that portion of the claim.

Any litigation activity on behalf of the State, or any of its subdivisions under this Section, must be coordinated with the Department of Attorney General. An attorney designated to represent the State may not do so until approved by the Michigan Attorney General and appointed as a Special Assistant Attorney General.

27. **Infringement Remedies.** If, in either party's opinion, any piece of equipment, software, commodity, or service supplied by Contractor or its subcontractors, or its operation, use or reproduction, is likely to become the subject of a copyright, patent, trademark, or trade secret infringement claim, Contractor must, at its expense: (a) procure for the State the right to continue using the equipment, software, commodity, or service, or if this option is not reasonably available to Contractor, (b) replace or modify the same so that it becomes non-infringing; or (c) accept its return by the State with appropriate credits to the State against Contractor's charges and reimburse the State for any losses or costs incurred as a consequence of the State ceasing its use and returning it.
28. **Limitation of Liability and Disclaimer of Damages. IN NO EVENT WILL THE STATE'S AGGREGATE LIABILITY TO CONTRACTOR UNDER THIS CONTRACT, REGARDLESS OF THE FORM OF ACTION, WHETHER IN CONTRACT, TORT, NEGLIGENCE, STRICT LIABILITY OR BY STATUTE OR OTHERWISE, FOR ANY CLAIM RELATED TO OR ARISING UNDER THIS CONTRACT, EXCEED THE MAXIMUM AMOUNT OF FEES PAYABLE UNDER THIS CONTRACT.** The State is not liable for consequential, incidental, indirect, or special damages, regardless of the nature of the action.
29. **Disclosure of Litigation, or Other Proceeding.** Contractor must notify the State within 14 calendar days of receiving notice of any litigation, investigation, arbitration, or other proceeding (collectively, "**Proceeding**") involving Contractor, a subcontractor, or an officer or director of Contractor or subcontractor, that arises during the term of the Contract, including: (a) a criminal Proceeding; (b) a parole or probation Proceeding; (c) a Proceeding under the Sarbanes-Oxley Act; (d) a civil Proceeding involving: (1) a claim that might reasonably be expected to adversely affect Contractor's viability or financial stability; or (2) a governmental or public entity's claim or written allegation of fraud; or (e) a Proceeding involving any license that Contractor is required to possess in order to perform under this Contract.
30. **State Data.** All data and information provided to Contractor by or on behalf of the State, and all data and information derived therefrom, is the exclusive property of the State ("**State Data**"); this definition is to be construed as broadly as possible. Upon request, Contractor must provide to the State, or a third party designated by the State, all State Data within 10 calendar days of the request and in the format requested by the State. Contractor will assume all costs incurred in compiling and supplying State Data. No State Data may be used for any marketing purposes.
31. **Reserved.**
32. **Non-Disclosure of Confidential Information.** The parties acknowledge that each party may be exposed to or acquire communication or data of the other party that is confidential, privileged communication not intended to be disclosed to third parties. The provisions of this Section survive the termination of this Contract.
 - a. Meaning of Confidential Information. For the purposes of this Contract, the term "**Confidential Information**" means all information and documentation of a party that: (a) has been marked "confidential" or with words of similar meaning, at the time of disclosure by such party; (b) if disclosed orally or not marked "confidential" or with words of similar meaning, was subsequently summarized in writing by the disclosing party and marked "confidential" or with words of similar meaning; and, (c) should reasonably be recognized as confidential information of the disclosing party. The term "Confidential Information" does not include any information or documentation that was: (a) subject to disclosure under the Michigan Freedom of Information Act (FOIA); (b) already in the possession of the receiving party without an

obligation of confidentiality; (c) developed independently by the receiving party, as demonstrated by the receiving party, without violating the disclosing party's proprietary rights; (d) obtained from a source other than the disclosing party without an obligation of confidentiality; or, (e) publicly available when received, or thereafter became publicly available (other than through any unauthorized disclosure by, though, or on behalf of, the receiving party). For purposes of this Contract, in all cases and for all matters, State Data is deemed to be Confidential Information.

- b. Obligation of Confidentiality. The parties agree to hold all Confidential Information in strict confidence and not to copy, reproduce, sell, transfer, or otherwise dispose of, give or disclose such Confidential Information to third parties other than employees, agents, or subcontractors of a party who have a need to know in connection with this Contract or to use such Confidential Information for any purposes whatsoever other than the performance of this Contract. The parties agree to advise and require their respective employees, agents, and subcontractors of their obligations to keep all Confidential Information confidential. Disclosure to a subcontractor is permissible where: (a) use of a subcontractor is authorized under this Contract; (b) the disclosure is necessary or otherwise naturally occurs in connection with work that is within the subcontractor's responsibilities; and (c) Contractor obligates the subcontractor in a written contract to maintain the State's Confidential Information in confidence. At the State's request, any employee of Contractor or any subcontractor may be required to execute a separate agreement to be bound by the provisions of this Section.
- c. Cooperation to Prevent Disclosure of Confidential Information. Each party must use its best efforts to assist the other party in identifying and preventing any unauthorized use or disclosure of any Confidential Information. Without limiting the foregoing, each party must advise the other party immediately in the event either party learns or has reason to believe that any person who has had access to Confidential Information has violated or intends to violate the terms of this Contract and each party will cooperate with the other party in seeking injunctive or other equitable relief against any such person.
- d. Remedies for Breach of Obligation of Confidentiality. Each party acknowledges that breach of its obligation of confidentiality may give rise to irreparable injury to the other party, which damage may be inadequately compensable in the form of monetary damages. Accordingly, a party may seek and obtain injunctive relief against the breach or threatened breach of the foregoing undertakings, in addition to any other legal remedies which may be available, to include, in the case of the State, at the sole election of the State, the immediate termination, without liability to the State, of this Contract or any Statement of Work corresponding to the breach or threatened breach.
- e. Surrender of Confidential Information upon Termination. Upon termination of this Contract or a Statement of Work, in whole or in part, each party must, within 5 calendar days from the date of termination, return to the other party any and all Confidential Information received from the other party, or created or received by a party on behalf of the other party, which are in such party's possession, custody, or control; provided, however, that Contractor must return State Data to the State following the timeframe and procedure described further in this Contract. Should Contractor or the State determine that the return of any Confidential Information is not feasible, such party must destroy the Confidential Information and must certify the same in writing within 5 calendar days from the date of termination to the other party. However, the State's legal ability to destroy Contractor data may be restricted by its retention and disposal schedule, in which case Contractor's Confidential Information will be destroyed after the retention period expires.

33. **Reserved.**

34. **Reserved.**

35. **Reserved.**

36. **Records Maintenance, Inspection, Examination, and Audit**. The State or its designee may audit Contractor to verify compliance with this Contract. Contractor must retain and provide to the State or its designee and the auditor general upon request, all financial and accounting records related to the Contract through the term of the Contract and for 4 years after the latter of termination, expiration, or final payment under this Contract or any extension ("**Audit Period**"). If an audit, litigation, or other action involving the records is initiated before the end of the Audit Period, Contractor must retain the records until all issues are resolved.

Within 10 calendar days of providing notice, the State and its authorized representatives or designees have the right to enter and inspect Contractor's premises or any other places where Contract Activities are being performed, and examine, copy, and audit all records related to this Contract. Contractor must cooperate and

provide reasonable assistance. If any financial errors are revealed, the amount in error must be reflected as a credit or debit on subsequent invoices until the amount is paid or refunded. Any remaining balance at the end of the Contract must be paid or refunded within 45 calendar days.

This Section applies to Contractor, any parent, affiliate, or subsidiary organization of Contractor, and any subcontractor that performs Contract Activities in connection with this Contract.

- 37. Warranties and Representations.** Contractor represents and warrants: (a) Contractor is the owner or licensee of any Contract Activities that it licenses, sells, or develops and Contractor has the rights necessary to convey title, ownership rights, or licensed use; (b) all Contract Activities are delivered free from any security interest, lien, or encumbrance and will continue in that respect; (c) the Contract Activities will not infringe the patent, trademark, copyright, trade secret, or other proprietary rights of any third party; (d) Contractor must assign or otherwise transfer to the State or its designee any manufacturer's warranty for the Contract Activities; (e) the Contract Activities are merchantable and fit for the specific purposes identified in the Contract; (f) the Contract signatory has the authority to enter into this Contract; (g) all information furnished by Contractor in connection with the Contract fairly and accurately represents Contractor's business, properties, finances, and operations as of the dates covered by the information, and Contractor will inform the State of any material adverse changes; (h) all information furnished and representations made in connection with the award of this Contract is true, accurate, and complete, and contains no false statements or omits any fact that would make the information misleading; and that (i) Contractor is neither currently engaged in nor will engage in the boycott of a person based in or doing business with a strategic partner as described in 22 USC 8601 to 8606. A breach of this Section is considered a material breach of this Contract, which entitles the State to terminate this Contract under Section 23, Termination for Cause.
- 38. Conflicts and Ethics.** Contractor will uphold high ethical standards and is prohibited from: (a) holding or acquiring an interest that would conflict with this Contract; (b) doing anything that creates an appearance of impropriety with respect to the award or performance of the Contract; (c) attempting to influence or appearing to influence any State employee by the direct or indirect offer of anything of value; or (d) paying or agreeing to pay any person, other than employees and consultants working for Contractor, any consideration contingent upon the award of the Contract. Contractor must immediately notify the State of any violation or potential violation of these standards. This Section applies to Contractor, any parent, affiliate, or subsidiary organization of Contractor, and any subcontractor that performs Contract Activities in connection with this Contract.
- 39. Compliance with Laws.** Contractor must comply with all federal, state and local laws, rules and regulations.
- 40. Prevailing Wage.** Contractor must comply with prevailing wage requirements, to the extent applicable to this Contract.
- 41. Reserved.**
- 42. Nondiscrimination.** Under the Elliott-Larsen Civil Rights Act, 1976 PA 453, MCL 37.2101, *et seq.*, the Persons with Disabilities Civil Rights Act, 1976 PA 220, MCL 37.1101, *et seq.*, and Executive Directive 2019-09. Contractor and its subcontractors agree not to discriminate against an employee or applicant for employment with respect to hire, tenure, terms, conditions, or privileges of employment, or a matter directly or indirectly related to employment, because of race, color, religion, national origin, age, sex (as defined in Executive Directive 2019-09), height, weight, marital status, partisan considerations, any mental or physical disability, or genetic information that is unrelated to the person's ability to perform the duties of a particular job or position. Breach of this covenant is a material breach of this Contract.
- 43. Unfair Labor Practice.** Under MCL 423.324, the State may void any Contract with a Contractor or subcontractor who appears on the Unfair Labor Practice register compiled under MCL 423.322.
- 44. Governing Law.** This Contract is governed, construed, and enforced in accordance with Michigan law, excluding choice-of-law principles, and all claims relating to or arising out of this Contract are governed by Michigan law, excluding choice-of-law principles. Any dispute arising from this Contract must be resolved in Michigan Court of Claims. Contractor consents to venue in Ingham County, and waives any objections, such as lack of personal jurisdiction or *forum non conveniens*. Contractor must appoint agents in Michigan to receive service of process.
- 45. Non-Exclusivity.** Nothing contained in this Contract is intended nor will be construed as creating any requirements contract with Contractor. This Contract does not restrict the State or its agencies from acquiring similar, equal, or like Contract Activities from other sources.

46. **Force Majeure.** Neither party will be in breach of this Contract because of any failure arising from any disaster or acts of god that are beyond their control and without their fault or negligence. Each party will use commercially reasonable efforts to resume performance. Contractor will not be relieved of a breach or delay caused by its subcontractors. If immediate performance is necessary to ensure public health and safety, the State may immediately contract with a third party.
47. **Dispute Resolution.** The parties will endeavor to resolve any Contract dispute in accordance with this provision. The dispute will be referred to the parties' respective Contract Administrators or Program Managers. Such referral must include a description of the issues and all supporting documentation. The parties must submit the dispute to a senior executive if unable to resolve the dispute within 15 business days. The parties will continue performing while a dispute is being resolved, unless the dispute precludes performance. A dispute involving payment does not preclude performance.

Litigation to resolve the dispute will not be instituted until after the dispute has been elevated to the parties' senior executive and either concludes that resolution is unlikely or fails to respond within 15 business days. The parties are not prohibited from instituting formal proceedings: (a) to avoid the expiration of statute of limitations period; (b) to preserve a superior position with respect to creditors; or (c) where a party makes a determination that a temporary restraining order or other injunctive relief is the only adequate remedy. This Section does not limit the State's right to terminate the Contract.

48. **Media Releases.** News releases (including promotional literature and commercial advertisements) pertaining to the Contract or project to which it relates must not be made without prior written State approval, and then only in accordance with the explicit written instructions of the State.
49. **Website Incorporation.** The State is not bound by any content on Contractor's website unless expressly incorporated directly into this Contract.
50. **Reserved.**
51. **Entire Agreement and Order of Precedence.** This Contract, which includes Schedule A – Statement of Work, and schedules and exhibits which are hereby expressly incorporated, is the entire agreement of the parties related to the Contract Activities. This Contract supersedes and replaces all previous understandings and agreements between the parties for the Contract Activities. If there is a conflict between documents, the order of precedence is: (a) first, this Contract, excluding its schedules, exhibits, and Schedule A – Statement of Work; (b) second, Schedule A – Statement of Work as of the Effective Date; and (c) third, schedules expressly incorporated into this Contract as of the Effective Date. NO TERMS ON CONTRACTOR'S INVOICES, ORDERING DOCUMENTS, WEBSITE, BROWSE-WRAP, SHRINK-WRAP, CLICK-WRAP, CLICK-THROUGH OR OTHER NON-NEGOTIATED TERMS AND CONDITIONS PROVIDED WITH ANY OF THE CONTRACT ACTIVITIES WILL CONSTITUTE A PART OR AMENDMENT OF THIS CONTRACT OR IS BINDING ON THE STATE FOR ANY PURPOSE. ALL SUCH OTHER TERMS AND CONDITIONS HAVE NO FORCE AND EFFECT AND ARE DEEMED REJECTED BY THE STATE, EVEN IF ACCESS TO OR USE OF THE CONTRACT ACTIVITIES REQUIRES AFFIRMATIVE ACCEPTANCE OF SUCH TERMS AND CONDITIONS.
52. **Severability.** If any part of this Contract is held invalid or unenforceable, by any court of competent jurisdiction, that part will be deemed deleted from this Contract and the severed part will be replaced by agreed upon language that achieves the same or similar objectives. The remaining Contract will continue in full force and effect.
53. **Waiver.** Failure to enforce any provision of this Contract will not constitute a waiver.
54. **Survival.** The provisions of this Contract that impose continuing obligations, including warranties and representations, termination, transition, insurance coverage, indemnification, and confidentiality, will survive the expiration or termination of this Contract.
55. **Contract Modification.** This Contract may not be amended except by signed agreement between the parties (a "**Contract Change Notice**"). Notwithstanding the foregoing, no subsequent Statement of Work or Contract Change Notice executed after the Effective Date will be construed to amend this Contract unless it specifically states its intent to do so and cites the section or sections amended.

Federal Provisions Addendum

The provisions in this addendum may apply if the purchase will be paid for in whole or in part with funds obtained from the federal government. If any provision below is not required by federal law for this Contract, then it does not apply and must be disregarded. If any provision below is required to be included in this Contract by federal law, then the applicable provision applies, and the language is not negotiable. If any provision below conflicts with the State's terms and conditions, including any attachments, schedules, or exhibits to the State's Contract, the provisions below take priority to the extent a provision is required by federal law; otherwise, the order of precedence set forth in the Contract applies. Hyperlinks are provided for convenience only; broken hyperlinks will not relieve Contractor from compliance with the law.

- 1. Federally Assisted Construction Contracts.** If this contract is a “**federally assisted construction contract**” as defined in 41 CFR Part 60-1.3, and except as otherwise may be provided under 41 CFR Part 60, then during performance of this Contract, the Contractor agrees as follows:

- (1)** The Contractor will not discriminate against any employee or applicant for employment because of race, color, religion, sex, sexual orientation, gender identity, or national origin. The Contractor will take affirmative action to ensure that applicants are employed, and that employees are treated during employment without regard to their race, color, religion, sex, sexual orientation, gender identity, or national origin. Such action shall include, but not be limited to the following:

Employment, upgrading, demotion, or transfer; recruitment or recruitment advertising; layoff or termination; rates of pay or other forms of compensation; and selection for training, including apprenticeship. The Contractor agrees to post in conspicuous places, available to employees and applicants for employment, notices to be provided setting forth the provisions of this nondiscrimination clause.

- (2)** The Contractor will, in all solicitations or advertisements for employees placed by or on behalf of the Contractor, state that all qualified applicants will receive consideration for employment without regard to race, color, religion, sex, sexual orientation, gender identity, or national origin.

- (3)** The Contractor will not discharge or in any other manner discriminate against any employee or applicant for employment because such employee or applicant has inquired about, discussed, or disclosed the compensation of the employee or applicant or another employee or applicant. This provision shall not apply to instances in which an employee who has access to the compensation information of other employees or applicants as a part of such employee's essential job functions discloses the compensation of such other employees or applicants to individuals who do not otherwise have access to such information, unless such disclosure is in response to a formal complaint or charge, in furtherance of an investigation, proceeding, hearing, or action, including an investigation conducted by the employer, or is consistent with the Contractor's legal duty to furnish information.

- (4)** The Contractor will send to each labor union or representative of workers with which he has a collective bargaining agreement or other contract or understanding, a notice to be provided advising the said labor union or workers' representatives of the Contractor's commitments under this section, and shall post copies of the notice in conspicuous places available to employees and applicants for employment.

- (5)** The Contractor will comply with all provisions of Executive Order 11246 of September 24, 1965, and of the rules, regulations, and relevant orders of the Secretary of Labor.

- (6)** The Contractor will furnish all information and reports required by Executive Order 11246 of September 24, 1965, and by rules, regulations, and orders of the Secretary of Labor, or pursuant thereto, and will permit access to his books, records, and accounts by the administering agency and the Secretary of Labor for purposes of investigation to ascertain compliance with such rules, regulations, and orders.

- (7)** In the event of the Contractor's noncompliance with the nondiscrimination clauses of this contract or with any of the said rules, regulations, or orders, this Contract may be canceled, terminated, or

suspended in whole or in part and the Contractor may be declared ineligible for further Government contracts or federally assisted construction contracts in accordance with procedures authorized in Executive Order 11246 of September 24, 1965, and such other sanctions may be imposed and remedies invoked as provided in Executive Order 11246 of September 24, 1965, or by rule, regulation, or order of the Secretary of Labor, or as otherwise provided by law.

(8) The Contractor will include the portion of the sentence immediately preceding paragraph (1) and the provisions of paragraphs (1) through (8) in every subcontract or purchase order unless exempted by rules, regulations, or orders of the Secretary of Labor issued pursuant to section 204 of Executive Order 11246 of September 24, 1965, so that such provisions will be binding upon each subcontractor or vendor. The Contractor will take such action with respect to any subcontract or purchase order as the administering agency may direct as a means of enforcing such provisions, including sanctions for noncompliance:

Provided, however, that in the event a Contractor becomes involved in, or is threatened with, litigation with a subcontractor or vendor as a result of such direction by the administering agency, the Contractor may request the United States to enter into such litigation to protect the interests of the United States.

2. Davis-Bacon Act (Prevailing Wage)

- a. If applicable, the Contractor (and its Subcontractors) for **prime construction contracts** in excess of \$2,000 must comply with the Davis-Bacon Act (40 USC 3141-3148) as supplemented by Department of Labor regulations (29 CFR Part 5, "Labor Standards Provisions Applicable to Contracts Covering Federally Financed and Assisted Construction").
- b. The Contractor (and its Subcontractors) shall pay all mechanics and laborers employed directly on the site of the work, unconditionally and at least once a week, and without subsequent deduction or rebate on any account, the full amounts accrued at time of payment, computed at wage rates not less than those stated in the advertised specifications, regardless of any contractual relationship which may be alleged to exist between the Contractor or subcontractor and the laborers and mechanics;
- c. The Contractor will post the scale of wages to be paid in a prominent and easily accessible place at the site of the work;
- d. There may be withheld from the Contractor so much of accrued payments as the contracting officer considers necessary to pay to laborers and mechanics employed by the Contractor or any Subcontractor on the work the difference between the rates of wages required by the Contract to be paid laborers and mechanics on the work and the rates of wages received by the laborers and mechanics and not refunded to the Contractor or Subcontractors or their agents.

3. **Copeland "Anti-Kickback" Act.** If applicable, the Contractor must comply with the Copeland "Anti-Kickback" Act (40 USC 3145), as supplemented by Department of Labor regulations (29 CFR Part 3, "Contractors and Subcontractors on Public Building or Public Work Financed in Whole or in Part by Loans or Grants from the United States"), which prohibits the Contractor and subrecipients from inducing, by any means, any person employed in the construction, completion, or repair of public work, to give up any part of the compensation to which he or she is otherwise entitled.

4. **Contract Work Hours and Safety Standards Act.** If the Contract is **in excess of \$100,000 and involves the employment of mechanics or laborers**, the Contractor must comply with 40 USC 3702 and 3704, as supplemented by Department of Labor regulations (29 CFR Part 5), as applicable.

5. **Rights to Inventions Made Under a Contract or Agreement.** If the Contract is funded by a federal "funding agreement" as defined under 37 CFR §401.2 (a) and the recipient or subrecipient wishes to enter into a contract with a small business firm or nonprofit organization regarding the substitution of parties, assignment or performance of experimental, developmental, or research work under that "funding agreement," the recipient or subrecipient must comply with 37 CFR Part 401, "Rights to Inventions Made by Nonprofit Organizations and Small Business Firms Under Government Grants, Contracts and Cooperative Agreements," and any implementing regulations issued by the awarding agency.

6. **Clean Air Act.** If this Contract is **in excess of \$150,000**, the Contractor must comply with all applicable standards, orders, and regulations issued under the Clean Air Act (42 USC 7401-7671q) and the Federal Water Pollution Control Act (33 USC 1251-1387). Violations must be reported to the federal awarding agency and the regional office of the Environmental Protection Agency.
7. **Debarment and Suspension.** A “contract award” (see 2 CFR 180.220) must not be made to parties listed on the government-wide exclusions in the System for Award Management (SAM), in accordance with the OMB guidelines at 2 CFR 180 that implement Executive Orders 12549 (3 CFR part 1986 Comp., p. 189) and 12689 (3 CFR part 1989 Comp., p. 235), “Debarment and Suspension.” SAM Exclusions contains the names of parties debarred, suspended, or otherwise excluded by agencies, as well as parties declared ineligible under statutory or regulatory authority other than Executive Order 12549.
8. **Byrd Anti-Lobbying Amendment.** If this Contract **exceeds \$100,000**, bidders and the Contractor must file the certification required under 31 USC 1352.
9. **Procurement of Recovered Materials.** Under 2 CFR 200.322, a non-Federal entity that is a state agency or agency of a political subdivision of a state **and its contractors** must comply with section 6002 of the Solid Waste Disposal Act, as amended by the Resource Conservation and Recovery Act. The requirements of Section 6002 include procuring only items designated in guidelines of the Environmental Protection Agency (EPA) at 40 CFR part 247 that contain the highest percentage of recovered materials practicable, consistent with maintaining a satisfactory level of competition, where the purchase price of the item exceeds \$10,000 or the value of the quantity acquired during the preceding fiscal year exceeded \$10,000; procuring solid waste management services in a manner that maximizes energy and resource recovery; and establishing an affirmative procurement program for procurement of recovered materials identified in the EPA guidelines.

Byrd Anti-Lobbying Certification

The following certification and disclosure regarding payments to influence certain federal transactions are made under FAR 52.203-11 and 52.203-12 and [31 USC 1352](#), the “Byrd Anti-Lobbying Amendment.” Hyperlinks are provided for convenience only; broken hyperlinks will not relieve Contractor from compliance with the law.

1. [FAR 52.203-12](#), “Limitation on Payments to Influence Certain Federal Transactions” is hereby incorporated by reference into this certification.
2. The bidder, by submitting its proposal, hereby certifies to the best of his or her knowledge and belief that:
 - a. No federal **appropriated** funds have been paid or will be paid to any person for influencing or attempting to influence an officer or employee of any agency, a member of Congress, an officer or employee of Congress, or an employee of a member of Congress on his or her behalf in connection with the awarding of any federal contract, the making of any federal grant, the making of any federal loan, the entering into of any cooperative agreement, and the extension, continuation, renewal, amendment or modification of any federal contract, grant, loan, or cooperative agreement;
 - b. If any funds **other than federal appropriated funds** (including profit or fee received under a covered federal transaction) have been paid, or will be paid, to any person for influencing or attempting to influence an officer or employee of any agency, a member of Congress, an officer or employee of Congress, or an employee of a member of Congress on his or her behalf **in connection with this solicitation**, the bidder must complete and submit, with its proposal, [OMB standard form LLL, Disclosure of Lobbying Activities](#), to the Solicitation Manager; and
 - c. He or she will include the language of this certification in all subcontract awards at any tier and require that all recipients of subcontract awards in excess of \$150,000 must certify and disclose accordingly.
3. This certification is a material representation of fact upon which reliance is placed at the time of Contract award. Submission of this certification and disclosure is a prerequisite for making or entering into this Contract under [31 USC 1352](#). Any person making an expenditure prohibited under this provision or who fails to file or amend the disclosure form to be filed or amended by this provision is subject to a civil penalty of not less than \$10,000, and not more than \$100,000, for each such failure.

STATE OF MICHIGAN

Contract No. 20000000373
Statewide – Anti-Ligature Furnishing Services

SCHEDULE A STATEMENT OF WORK CONTRACT ACTIVITIES

BACKGROUND

Michigan Department of Health and Human Services (MDHHS)

MDHHS is seeking to establish a Contract(s) for the purchase of Anti-ligature furniture for all State Hospitals as well as Juvenile Detention Centers. The State of Michigan Hospitals are operated in accordance with the Standards set forth by The Joint Commission (TJC), Center for Medicare and Medicaid Services (CMS) and MDHHS regulations. The Contractor(s) assigned must be able to meet the specifications for furnishing as set in this Contract.

The following hospitals have a need for Anti-Ligature Furniture:

- Hawthorn Center – 18471 Haggerty Road, Northville, MI 48167
- Center for Forensic Psychiatry (CFP) – 8303 Platt Road, Saline, MI 48176
- Kalamazoo Psychiatric Hospital (KPH) – 1312 Oakland Drive, Kalamazoo, MI 49008
- Caro Center – 2000 Chambers Road, Caro, MI 48723
- Walter Reuther Psychiatric Hospital (WRPH) – 30901 Palmer Road, Westland, MI 48186
- Juvenile Justice Residential (JJB) Facility
 - Bay Pines Center – 2425 N 30th Street, Escanaba, MI 49829
 - Shawono Center – 10 N Howes Lake, Road, Grayling, MI 49738

Department Military and Veterans Affairs (DMVA)

DMVA is seeking to establish a means for purchase of Anti-ligature furniture for all State Facilities including live-in homes. DMVA facilities operate in accordance with the Standards set forth by the Joint Commission (TJC), Center for Medicare and Medicaid Services (CMS) and DMVA regulations. The Contractor assigned must be able to meet the specifications set in this Contract.

SCOPE

The Michigan Department of Health and Human Services (MDHHS) along with the Department for Military and Veterans Affairs (DMVA); have a need for anti-ligature, psychiatric/behavioral health furniture. Furniture must be designed in a way to eliminate points where a rope, clothing or bed sheet can be looped around to cause self-harm to a client. Furniture must also have a way to be secured to a wall or floor to prevent the piece of furniture from being picked up or moved. Furniture surfaces must be stain-resistant, and not be moisture absorbent.

Please Note: additional State Agencies may request use of this Contract; additional Agencies will be added via Contract Change Notice.

REQUIREMENTS

1. General Requirements

1.1. Product Specifications

The Contractor must provide Anti-Ligature Furnishings meeting that specifications of Schedule C – Product Specifications, and the Standards set forth by The Joint Committee (TJC) and Center for Medicare and Medicaid Services (CMS), MDHHS regulations and/or DMVA regulation.

Please Note: Schedule C – is not an all-inclusive list of items, the State may request additional items for purchase on an as needed basis.

Please refer to Schedule D – Vendor Products – Endurance for the following items:

- Cortech Endurance Desks and Chests
- Cortech Chairs
- Cortech Endurance Beds
- Cortech Endurance Tables
- Cortech Property Storage Boxes
- Derby SEG-MAX Pinnacle Mattress (Schedule E - Derby SEG-MAX Pinnacle Mattress)

For the full line of Endurance products and pricing please refer to www.cortechusa.com.

1.2 Additional Products

The Contractor may offer alternate Anti-Ligature Furnishings that vary from the specifications outlined in Schedule C. Alternate furnishing must be clearly described, all variances from the specifications in this proposal must include descriptive literature that contains complete specifications.

Please Note:

- Completion of this requirement is only necessary if your organization wishes to include alternate items for consideration.
- For items offered that do not meet the specifications outline in Section 1.1 – DMVA reserves the right to request a Demo of proposed products.
- For all other CortechUSA all other product lines, please refer to www.cortechusa.com.

1.3. Warranties

The Contractor will handle any repairs or replacements for products recalled, and offer the following warranties for products offered:

- Warranty time frames vary depending upon the product purchased ranging from 1 – 10 years.
- Cortech's Manufacturer Warranty covers any defects as a result of the manufacturing process or failure of a product within that product's normal expected use.

Warranty Claim Process:

- When evaluating warranty claims, Cortech asks for a detailed description of the defect or issue and the circumstances surrounding/leading to said defect/issue, as well as pictures of the product's defects/damages.
- Upon receipt of all information and pictures surrounding the warranty claim, Cortech will work with the end user to resolve the claim if it is determined that the product(s) has either manufacturing defects OR has failed within that product(s) normal expected use.

Please Note: The State reserves the right to require additional warranties other than those identified by the Contractor in this Contract.

1.4. Recall Requirements and Procedures

The Contractor must notify the State's applicable Program Manager when a recall is issued, to schedule a date and time to repair items on-site or replace/exchange recalled items.

1.5. Quality Assurance Program

Quality Assurance Program(s) must be continuously evaluated and improve the quality of service received by the State. Any proposed program(s) must include the following components:

1. Measurement of Key Performance indicators (KPIs)
2. Implementation of individual and system interventions to improve the quality of services;
3. Evaluation of the effectiveness of the interventions, and
4. Planning and initiation of activities for increasing and maintaining improvements in service quality

5. Plan must ensure compliance with TJC standards, including the Seven Environments of care required by TJC. Please use the link below for further details:
https://www.jointcommission.org/assets/1/6/2019_All_Programs_Organization_Survey_Activity_Guide.pdf
- a. Safety;
 - b. Security;
 - c. Hazardous materials and waste;
 - d. Emergency management
 - e. Fire risk management
 - f. Medical equipment, and
 - g. Utilities

Please Note: The Contractor must work with the State to finalize and implement a quality assurance program(s), that meet the specifications above. Specifications are subject to change.

1.6. Incentives

Please refer to Schedule B – Pricing for a full list of special incentives or services including, but not limited to, return polices, restocking policies*, trade-in programs, quantity/volume discounts, or any other incentives offered.

*restocking fees, or associated charges must be built into the Contractors' proposed pricing as defined in Schedule B – Pricing, item 1. Restocking fees of any kind have been waived and will not be invoiced for.

1.7 Training

During the life of the Contract, and at the request of the State the Contractor must provide the following training:

- Ordering Processes & Procedures
- Shipping & Billing
- Delivery Processes
- Warranty Services
- Product Information and Application/Use Guidelines
- Web-based catalog – if applicable
- Any additional training that may be deemed necessary

Please Note:

- Training will be provided to the State at no additional cost.
- The Contractor must have the ability to and provide training materials upon request.

1.8. Reporting

The Contractor must submit to the requesting Program Area and/or Program Manager, the following written reports:

Please Note: Reports are due on a Monthly basis and must be submitted to the Program Manager(s) no later than the 15th day of the following month. Reports must also be made available to the State upon request.

- **Itemized Purchased Reports**
 - Reports must reflect the total number of items purchased by all agencies, as well as, individual agency.
- **Open invoice report**
 - Reports should show which invoices are currently outstanding and amount due
- **Deliver Report**
 - Reports should indicate address, time of delivery, items delivered and their condition at deliver, any refused or damaged items
 - A supplemental report should indicate the action plan to correct and deliver replacement items. If items were refused at the time of deliver – please indicate why: ordered by mistake, damaged, wrong items etc.
- **Purchasing Activity Report**
 - Reports must separate product design, product line, or product style etc.
 - Installation, if applicable
- **Lead Time Report**
 - Order specific performance and data by product line
 - Data should be displayed in the following format:

- On-time and Complete Shipments, including shipment location
- Average lead time by product line
- Days to process and enter orders
- Requested shipment receipt dates – differentiate which shipment request were completed on-time and past receipt date
- **Sales History Report**
 - Indicate the quantity of sales for each item by product line, style and design
 - Reports should be presented by Agency, and broken down into requesting facility, as well as presented by Statewide totals
- **Other – Additional Reports**
 - Any additional report the State may request; please note the State will work with the Contractor to develop and implement additional reports requested.

2. Staffing

2.1. Contractor Representative

The Contractor must appoint at least one individual, specifically assigned to State of Michigan accounts, that will respond to State inquiries regarding the Contract Activities, answering questions related to ordering and delivery, etc. (the "Contractor Representative").

The Contractor must notify the Contract Administrator at least 15 calendar days before removing or assigning a new Contractor Representative.

Contractor Representative: Jason Fisher
Phone: 640-455-0811 or, 800-571-0770
Email: Jason@cortechusa.com

2.2. Customer Service Toll-Free Number

The Contractor must specify its toll-free number for the State to make contact with the Contractor Representative. The Contractor Representative must be available for calls during the hours of 8:00a.m. to 5:00p.m. EST.

Toll-free Contact Number: 800-571-0770

2.3. Technical Support, Repairs and Maintenance

The Contractor must specify its toll-free number for the State to make contact with the Contractor for technical support, repairs and maintenance. The Contractor must be available for calls and service during the hours of 8:00a.m. to 5:00p.m. EST.

When providing support, the Call Center must resolve the caller's issues within 30 minutes. If issue resolution cannot be provided within 30 minutes – due to complexity of the request, issues must be resolved within 48-hours of submission.

Toll-free Contact Number: 800-571-0770
 ATTN: Support and Maintenance

2.4. Key Personnel

The Contractor must appoint at a minimum 3 individuals who will be directly responsible for the day to day operations of the Contract ("Key Personnel"). Key Personnel must be specifically assigned to the State account, be knowledgeable on the contractual requirements, and respond to State inquires within 48 hours.

The Contractor may not remove or assign Key Personnel without the prior consent of the State. Prior consent is not required for reassignment for reasons beyond the Contractor's control, including illness, disability, death, leave of absence, personal emergency circumstances, resignation, or termination for cause. The State may request a résumé and conduct an interview before approving a change. The State may require a 30-calendar day training period for replacement personnel. The Contractor must identify the Key Personnel, indicate where they will be physically located, describe the functions they will perform, and provide current chronological résumés.

2.4. Key Personnel - Continued

Key Personnel Table			
Position	Name (First and Last)	Physical Location of Employment	Years of Experience in Current Role
1. Account Manager	Janie Jennings	Willowbrook, IL	0.5 years
2. Account Representative	Amanda Owen	Willowbrook, IL	2.5 years
3. Contractor Representative	Jason Fisher	Willowbrook, IL	2.5 years
4. Contract Administrator	Pat Miller	Willowbrook, IL	15 years
5. Contract Administrator	Dave Jennings	Willowbrook, IL	5 years
6. Contract Administrator	Bhavika Lavingia	Willowbrook, IL	0.25 years

2.5. Organizational Chart

Cortech USA Organization List	
Name	Position
Joe Claffy	President/CEO
Pat Miller	CFO
Dave Jennings	COO
Steve Csuk	Regional Sales Manager
Jason Fisher	Regional Sales Manager
Amanda Owens	Account Manager
Jair Aguilar	Warehouse/Shipping Supervisor
Caren Fatigato	Account Coordinator
Janie Jennings	Account Manager
Bhavika Lavingia	Sales Support

2.6. Disclosure of Subcontractors

If the Contractor intends to utilize subcontractors, the Contractor must disclose the following:

- The legal business name; address; telephone number;
- A description of subcontractor’s organization and the services it will provide; and information concerning subcontractor’s ability to provide the Contract Activities.
 - A complete description of the Contract Activities that will be performed or provided by the subcontractor.
- The relationship of the subcontractor to the Contractor.
 - Whether the Contractor has a previous working experience with the subcontractor. If yes, provide the details of that previous relationship.

Please Note: If your organization is not currently utilizing subcontracted services, but may in the future, the above information must then be provided.

2.7. Security

The Contractor’s staff may be required to make deliveries to or enter State facilities. The Contractor will be subject the following security procedures:

The Contractor must:

- (a) explain how it intends to ensure the security of State facilities,
- (b) whether it uses uniforms and ID badges, etc.,
- (c) identify the company that will perform background checks, and
- (d) the scope of the background checks.

Please Note: The State may require the Contractor’s personnel to wear State issued identification badges. The Contractor must explain any additional security measures in place to ensure the security of State facilities.

2.8. Meetings

The Contractor must attend the following meetings:

- Kick-off meeting within 30-calendar days of the Contract Effective Date
- Weekly/bi-weekly implementation update meetings – if applicable
- Introduction meeting – if applicable
- Weekly review and status meeting:
 - This meeting will be held between the Contractor's Program Manager and the State, to review process and performance – if applicable
- Quarterly Review Meetings
- Any other State may request other meetings as it deems appropriate.

3. Electronic Catalog

To enable catalog management functionality, the Contractor must supply the State with product and pricing information as identified in Schedule B – Pricing of this Contract.

The State's preferred method for catalog management is online – please indicate where your organizations current pricing and product offerings can be viewed. If web-based view for catalogs is not available, please indicate your process for catalog management.

Web-Based Catalog Available at: https://issuu.com/allegra859/docs/cortech_catalog_2013?e=2326388/1223994

Catalog, Hard Copy: Copies are available by contacting Jason Fisher at:

- 630-445-0811 or email Jason@cortechusa.com
- Please refer to www.Cortech.com for additional vendor information

Please Note: The Contractor must supply the State with updated product and pricing information over the duration of the Contract. Should product and price change, changes will not take effect until the catalog is updated in the State's procurement system.

4. Ordering

4.1. Authorizing Document

The appropriate authorizing document for the Contract will be a Delivery Order (DO).

4.2 Order Verification

The Contractor must have internal controls, to verify abnormal orders and to ensure that only authorized individuals place orders.

- For every order placed the Contractor must provide the ordering party with a tracking number, or other means to track the order and shipment of products purchased.
 - Cortech will provide a shipping/invoice document upon order for tracking purposes.

5. Delivery

5.1. Delivery Programs

The Contractor must explain in detail its delivery programs (e.g., standard delivery and quick ship), including any limitations such as quantity.

The Contractor must explain the transportation method (e.g., UPS, FedEx, Contractor fleet, or other third-party carrier) it intends on utilizing in delivery of the Contract Activities.

- **Order Delivery Method:** Cortech uses 3rd Party carriers, FedEx and UPS for most deliveries.

Please Note: The Contractor must make available a request for delivery date to State Agencies. Special delivery request should be processed and delivered to the State at no additional cost.

5.2. Packaging and Palletizing

Packaging must be optimized to permit the lowest freight rate. Shipments must be palletized whenever possible using manufacturer's standard 4-way shipping pallets.

5.3. Installation

Cortech does not provide installation services – products can be installed (when applicable) by facility maintenance staff. Detailed instructions are provided for all items that required installation. Cortech Does not provide hardware needed for most products, however, provides recommendation of needed hardware, and recommend locations where recommended hardware can be purchased.

6. Acceptance

6.1. Acceptance, Inspection and Testing

The State will use the acceptance process defined in Section 16, Acceptance of the Standard Contract Terms.

Please Note: The State Agency representative, or designee, will review and inspect order shipment documents and approve acceptance of good upon delivery. Shipment documents should include product details, quantities to be delivered, delivery location, date and time, and any additional information that may be requested at a later date.

7. Invoice and Payment

7.1. Invoice Requirements

Invoices will be paid in accordance with Section 20, of the Standard Contract Terms.

All invoices submitted to the State must include:

- (a) Contract Number
- (b) Delivery Order
- (c) Project Reference
- (d) Date
- (e) Quantity & Unit Price
- (f) Description of the Contract Activities (Service and/or product provided);
- (g) Unit price
- (h) Shipping cost
- (i) Total Price

Please Note: The State may require alterations to invoice detail at any point throughout the term of the Contract. If applicable, for installation of projects purchased invoices must also list items J and K:

- (j) Labor hours (removal, cleaning, preparation etc.)
- (k) Service provided & delivery date(s)

7.2. Payment Methods

The State will make payment for Contract Activities by Electronic Fund Transfer (EFT).

8. Pricing

8.1. Price Term

Pricing is firm for the first five-years ("Pricing Period"). The first pricing period begins on the Effective Date. Adjustments may be requested, in writing, by either party and will take effect no earlier than the next Pricing Period.

8.2. Price Changes

Adjustments will be based on changes in actual Contractor costs. Any request must be supported by written evidence documenting the change in costs. The State may consider sources, such as the Consumer Price Index; Producer Price Index; other pricing indices as needed; economic and industry data; manufacturer or supplier letters noting the increase in pricing; and any other data the State deems relevant.

Following the presentation of supporting documentation, both parties will have 30 days to review the information and prepare a written response. If the review reveals no need for modifications, pricing will remain unchanged unless mutually agreed to by the parties. If the review reveals that changes are needed, both parties will negotiate such changes, for no longer than 30 days, unless extended by mutual agreement.

The Contractor remains responsible for Contract Activities at the current price for all orders received before the mutual execution of a Change Notice indicating the start date of the new Pricing Period.

9. Liquidated Damages

- a. Late or improper completion of the Contract Activities will cause loss and damage to the State and it would be impracticable and extremely difficult to fix the actual damage sustained by the State. Therefore, if there is late or improper completion of the Contract Activities the State is entitled to collect liquidated damages in the amount of \$5,000 and an additional \$100 per day for each day Contractor fails to remedy the late or improper completion of the Work.
- b. Unauthorized Removal of Key Personnel will interfere with the timely and proper completion of the Contract, to the loss and damage of the State, and it would be impracticable and extremely difficult to fix the actual damage sustained by the State. Therefore, the State may assess liquidated damages against Contractor as specified below.

The State is entitled to collect \$1,000 per individual per day for the removal of any Key Personnel without prior approval of the State. The State is entitled to collect \$1,000 per individual per day for an unapproved or untrained key personnel replacement.

10. Service Levels

10.1. Time Frames

All Contract Activities must be delivered within the timeframes specified below in order to meet the needs of the State. The receipt of order date is pursuant to Section 2, Notices, of the Standard Contract Terms.

a. Delivery

Delivery will be expected within 45-business days from receipt of order, delivery will be made at various locations. If delivery is delayed, a new delivery date will be communicated and agreed upon with the purchasing area.

The Contractor must credit the State 1% of the purchase total for deliveries that exceed the 45-business day delivery window, for late deliveries that are not communicated to the State. A 1% additional credit will be assessed for each additional day that the delivery is delayed.

Please Note: a credit will not be assessed for delayed deliveries that are outside of the control of the Contractor please refer to Section 46. Force Majeure of the Standard Contract terms.

b. Invoicing and Accounting Credits

Failure to provide invoices in the manner specified in Section 8.1 Invoices will result in a credit of 1% of the invoice total back to the State.

c. Customer Services

When providing support, the Call Center must resolve the caller's issues within 30 minutes. If issue resolution cannot be provided within 30 minutes – due to complexity of the request, issues must be resolved within 48-hours of submission.

Failure to provide resolution, or response, will result in a \$500.00 credit to the State.

d. Warranty Services

The Contractor must provide warranty service response within 48-hours of the State's request. Provide service or product replacement within 10-business days of determination of need. Schedule all services so as not to interfere with activities within space, at no charge to the State.

Failure to provide response to a warranty service request within 48-hours of receipt of request, or to provide service or product replacement within 10-business days of determination of need will result in a \$500.00 per occurrence credit to the State.

11. Additional Requirements

11.1. Environmental and Energy Efficient Products

The Contractor must identify any energy efficient, bio-based, or otherwise environmentally friendly products used in the products. Contractor must include any relevant third-party certification, including the verification of a United States department of agriculture certified bio-based product label.

11.2. Hazardous Chemical Identification

In accordance with the federal Emergency Planning and Community Right-to-Know Act, 42 USC 11001, *et seq.*, as amended, the Contractor must provide a Material Safety Data Sheet listing any hazardous chemicals, as defined in 40 CFR §370.2, to be delivered. Each hazardous chemical must be properly identified, including any applicable identification number, such as a National Stock Number or Special Item Number.

The Contractor must identify any hazardous chemicals that will be provided under any resulting contract.

11.3. Mercury Content

Pursuant to MCL 18.1261d, mercury-free products must be procured when possible. The Contractor must explain if it intends to provide products containing mercury, the amount or concentration of mercury, and whether cost competitive alternatives exist. If a cost competitive alternative does exist, the Contractor must provide justification as to why the particular product is essential. All products containing mercury must be labeled as containing mercury.

11.4. Brominated Flame Retardants

The State prefers to purchase products that do not contain brominated flame retardants (BFRs) whenever possible. The Contractor must disclose whether the products contain BFRs.

STATE OF MICHIGAN

Contract No. 200000000373
Statewide – Anti-Ligature Furnishing Services

SCHEDULE B PRICING

1. Price proposals must include all costs, including but not limited to, any one-time or set-up charges, fee, and potential costs that Contractor may charge the State (e.g. shipping and handling, per piece pricing and palletizing).
2. Quick payment terms: 1 % discount off invoice if paid within 10 days after receipt of invoice.
Quick payment terms: 1½ % discount off invoice if paid within 15 days after receipt of invoice.
3. Quantity/Volume terms:
 - Quantity discount 5% off orders greater than \$50,000.00
 - Year-to-Date Total Quantity discount: An additional 5% discount will be applied on year-to-date orders exceed \$100,000.00, for the remained of the calendar year, to be rest annually.
 - Freight included Pricing for items listed in Schedule B – The contractor will re-calculate freight to include and exclude freight as a separate line item when freight is less than the Current List Pricing with Freight Included Pricing. The Contractor with the State on an order-by-order basis to determine best pricing for freight.

DESCRIPTION	PART NUMBER	Single Item Price	Skid Qty per piece	Skid Qty
Furniture, Seating & Mattresses				
EZ Bunk(TM) Sleep Surface Grey	7501	\$332.17	\$185.00	20
EZ Bunk(TM) Sleep Surface Blue	7502	\$332.17	\$185.00	20
Barracuda Box 1.5 cu ft	3825P	\$51.17	\$28.00	32
Barracuda Box 2.0 cu ft	7268P	\$52.77	\$29.07	32
Barracuda Box Lid universal	9689	\$48.02	\$23.00	32
Barracuda Box 3.0 cu ft	8568P	\$63.09	\$50.00	18
Barracuda Box Lid for 3.0 cu ft	8289P	\$51.78	\$28.64	64
Masterbox 1.5	3825M	\$63.45	\$42.75	32
Masterbox 2.0	7268M	\$65.17	\$50.00	32
Masterbox 1.5/2.0 Lid	9689M	\$52.44	\$24.00	128
Masterbox 3.0	8568M	\$74.84	\$66.00	18
Masterbox 3.0 Lid	8289M	\$56.30	\$31.00	64
Stackable Chair Slate Blue	86484SB	NA	\$36.00	50
Stackable Chair Blue Gray	86484BG	NA	\$36.00	50
Stackable Chair Buff	86484B	NA	\$36.00	50
Stackable Chair Plum	86484P	NA	\$36.00	50
Stackable Chair Fog Gray	86484FG	NA	\$36.00	50
Stackable Chair Black	86484BK	NA	\$36.00	50
Stackable ChairTeal	86484T	NA	\$36.00	50
Stackable Chair Green	86484GN	NA	\$43.00	50
Stackable Chair Brown	86484BN	NA	\$43.00	50
Stackable Chair Slate Blue	86484SB	NA	\$42.00	25
Stackable Chair Blue Gray	86484BG	NA	\$42.00	25
Stackable Chair Buff	86484B	NA	\$42.00	25

Stackable Chair Plum	86484P	NA	\$42.00	25
Stackable Chair Fog Gray	86484FG	NA	\$42.00	25
Stackable Chair Black	86484BK	NA	\$42.00	25
Stackable ChairTeal	86484T	NA	\$42.00	25
Stackable Chair Green	86484GN	NA	\$50.00	25
Stackable Chair Brown	86484BN	NA	\$50.00	25
Sabre Chair-floor mount, gangable Black	96484BK	\$284.91	\$223.00	4
Sabre Chair-floor mount, gangable Grey	96484GY	\$284.91	\$223.00	4
Sabre Chair-floor mount, gangable Slate Blue	96484SB	\$284.91	\$223.00	4
Sabre Chair-floor mount, gangable Brown	96484BN	\$284.91	\$223.00	4
Sabre Chair-floor mount, gangable Green	96484GN	\$284.91	\$223.00	4
Sabre Chair-floor mount, gangable Blue Grey	96484BG	\$284.91	\$223.00	4
Sabre Chair-floor mount, gangable Sand	96484SD	\$284.91	\$223.00	4
Sabre Chair-floor mount, gangable Burgundy	96484BY	\$284.91	\$223.00	4
Sabre Chair floor mount, gangable with access door Black	96484BKS	\$312.90	\$260.00	4
Sabre Chair floor mount, gangable with access door Grey	96484GYS	\$312.90	\$260.00	4
Sabre Chair floor mount, gangable with access door Slate Blue	96484SBS	\$312.90	\$260.00	4
Sabre Chair floor mount, gangable with access door Brown	96484BNS	\$312.90	\$260.00	4
Sabre Chair floor mount, gangable with access door Green	96484GNS	\$312.90	\$260.00	4
Sabre Chair floor mount, gangable with access door Blue Grey	96484BGS	\$312.90	\$260.00	4
Sabre Chair floor mount, gangable with access door Sand	96484SDS	\$312.90	\$260.00	4
Sabre Chair floor mount, gangable with access door Burgundy	96484BYS	\$312.90	\$260.00	4
Sentinel Armless Chair-floor mount, gangable Black	116484BK	\$271.81	\$175.00	8
Sentinel Armless Chair-floor mount, gangable Grey	116484GY	\$271.81	\$175.00	8
Sentinel Armless Chair-floor mount, gangable Slate Blue	116484SB	\$271.81	\$175.00	8
Sentinel Armless Chair-floor mount, gangable Brown	116484BN	\$271.81	\$175.00	8
Sentinel Armless Chair-floor mount, gangable Green	116484GN	\$271.81	\$175.00	8
Sentinel Armless Chair-floor mount, gangable Blue Grey	116484BG	\$271.81	\$175.00	8

Sentinel Armless Chair-floor mount, gangable Burgundy	116484BY	\$271.81	\$175.00	8
Sentinel Armless Chair-floor mount, gangable Sand	116484SD	\$271.81	\$175.00	8
Sentinel Armless Chair floor mount, gangable with access door Black	116484BKS	\$298.98	\$212.00	8
Sentinel Armless Chair floor mount, gangable with access door Grey	116484GYS	\$298.98	\$212.00	8
Sentinel Armless Chair floor mount, gangable with access door Slate Blue	116484SBS	\$298.98	\$212.00	8
Sentinel Armless Chair floor mount, gangable with access door Brown	116484BNS	\$298.98	\$212.00	8
Sentinel Armless Chair floor mount, gangable with access door Green	116484GNS	\$298.98	\$212.00	8
Sentinel Armless Chair floor mount, gangable with access door Blue Grey	116484BGS	\$298.98	\$212.00	8
Sentinel Armless Chair floor mount, gangable with access door Sand	116484SDS	\$298.98	\$212.00	8
Sentinel Armless Chair floor mount, gangable with access door Burgundy	116484BYS	\$298.98	\$212.00	8
Sentinel Arm Chair-floor mount, gangable Black	106484BK	\$275.96	\$180.00	8
Sentinel Arm Chair-floor mount, gangable Grey	106484GY	\$275.96	\$180.00	8
Sentinel Arm Chair-floor mount, gangable Slate Blue	106484SB	\$275.96	\$180.00	8
Sentinel Arm Chair-floor mount, gangable Brown	106484BN	\$275.96	\$180.00	8
Sentinel Arm Chair-floor mount, gangable Green	106484GN	\$275.96	\$180.00	8
Sentinel Arm Chair-floor mount, gangable Blue Grey	106484BG	\$275.96	\$180.00	8
Sentinel Arm Chair-floor mount, gangable Sand	106484SD	\$275.96	\$180.00	8
Sentinel Arm Chair-floor mount, gangable Burgundy	106484BY	\$275.96	\$180.00	8
Sentinel Arm Chair floor mount, gangable with access door Black	106484BKS	\$293.08	\$204.00	8
Sentinel Arm Chair floor mount, gangable with access door Grey	106484GYS	\$293.08	\$204.00	8
Sentinel Arm Chair floor mount, gangable with access door Slate Blue	106484SBS	\$293.08	\$204.00	8
Sentinel Arm Chair floor mount, gangable with access door Brown	106484BNS	\$293.08	\$204.00	8
Sentinel Arm Chair floor mount, gangable with access door Green	106484GNS	\$293.08	\$204.00	8
Sentinel Arm Chair floor mount, gangable with access door Blue Grey	106484BGS	\$293.08	\$204.00	8
Sentinel Arm Chair floor mount, gangable with access door Sand	106484SDS	\$293.08	\$204.00	8
Sentinel Arm Chair floor mount, gangable with access door Burgundy	106484BYS	\$293.08	\$204.00	8
Radial Rocker Black	146484BK	\$420.00	\$375.00	2
Radial Rocker Grey	146484GY	\$420.00	\$375.00	2

Radial Rocker Slate Blue	146484SB	\$420.00	\$375.00	2
Radial Rocker Brown	146484BN	\$420.00	\$375.00	2
Radial Rocker Green	146484GN	\$420.00	\$375.00	2
Radial Rocker Blue Grey	146484BG	\$420.00	\$375.00	2
Radial Rocker Sand	146484SD	\$420.00	\$375.00	2
Radial Rocker Burgundy	146484BY	\$420.00	\$375.00	2
Endurance Bench Black	136484BK	\$485.00	\$453.15	10
Endurance Bench Blue Grey	136484BG	\$485.00	\$453.15	10
Endurance Bench Brown	136484BN	\$485.00	\$453.15	10
Endurance Bench Green	136484GN	\$485.00	\$453.15	10
Endurance Bench Grey	136484GY	\$485.00	\$453.15	10
Endurance Bench Slate Blue	136484SB	\$485.00	\$453.15	10
Endurance Bench Sand	136484SD	\$485.00	\$453.15	10
Endurance Bench Burgundy	136484BY	\$485.00	\$453.58	10
Endurance Cube Black	126484BK	\$267.46	\$196.65	18
Endurance Cube Blue Grey	126484BG	\$267.46	\$196.65	18
Endurance Cube Brown	126484BN	\$267.46	\$196.65	18
Endurance Cube Green	126484GN	\$267.46	\$196.65	18
Endurance Cube Grey	126484GY	\$267.46	\$196.65	18
Endurance Cube Slate Blue	126484SB	\$267.46	\$196.65	18
Endurance Cube Sand	126484SD	\$267.46	\$196.65	18
Endurance Cube Burgundy	126484BY	\$267.46	\$196.65	18
Endurance Cube Black with Access Door	126484BKS	\$294.63	\$222.30	18
Endurance Cube Blue Grey with Access Door	126484BGS	\$294.63	\$222.30	18
Endurance Cube Brown with Access Door	126484BNS	\$294.63	\$222.30	18
Endurance Cube Green with Access Door	126484GNS	\$294.63	\$222.30	18
Endurance Cube Grey with Access Door	126484GYS	\$294.63	\$222.30	18
Endurance Cube Slate Blue with Access Door	126484SBS	\$294.63	\$222.30	18

Endurance Cube Sand with Access Door	126484SDS	\$294.63	\$222.30	18
Endurance Cube Burgundy with Access Door	126484BYS	\$294.63	\$222.30	18
Trash Can Black 10 quart Flame Retardant (6 pack)	710-BK	\$130.00	\$105.17	120
Trash Can Grey 10 quart Flame Retardant (6 pack)	710-GY	\$130.00	\$105.17	120
Trash Can Slate Blue 10 quart Flame Retardant (6 pack)	710-SB	\$130.00	\$105.17	120
Trash Can Green 10 quart Flame Retardant (6 pack)	710-GN	\$130.00	\$105.17	120
Trash Can Brown 10 quart Flame Retardant (6 pack)	710-BN	\$130.00	\$105.17	120
Trash Can Blue Gray 10 quart Flame Retardant (6 pack)	710-BG	\$130.00	\$105.17	120
Trash Can Sand 10 quart Flame Retardant (6 pack)	710-SD	\$130.00	\$105.17	120
Trash Can Black 14 quart Flame Retardant (6 pack)	714-BK	\$135.00	\$112.86	120
Trash Can Grey 14 quart Flame Retardant (6 pack)	714-GY	\$135.00	\$112.86	120
Trash Can Slate Blue 14 quart Flame Retardant (6 pack)	714-SB	\$135.00	\$112.86	120
Trash Can Green 14 quart Flame Retardant (6 pack)	714-GN	\$135.00	\$112.86	120
Trash Can Blue Gray 14 quart Flame Retardant (6 pack)	714-BG	\$135.00	\$112.86	120
Trash Can Sand 14 quart Flame Retardant (6 pack)	714-SD	\$135.00	\$112.86	120
Trash Can Brown 14 quart Flame Retardant (6 pack)	714-BN	\$135.00	\$112.86	120
Acrylic Mirror 11x15	VM1115	N/A	\$48.74	Only Cases of 10
Acrylic Mirror 15x20	VM1520	N/A	\$64.13	Only Cases of 10
Acrylic Mirror 18x24	VM1824	N/A	\$85.50	Only Cases of 10
Endurance Bed 0.0, Black	7500BK	\$690.00	\$662.63	6
Endurance Bed 0.0, Slate Blue	7500SB	\$690.00	\$662.63	6
Endurance Bed 0.0, Green	7500GN	\$690.00	\$662.63	6
Endurance Bed 0.0, Brown	7500BN	\$690.00	\$662.63	6
Endurance Bed 0.0, Blue/Gray	7500BG	\$690.00	\$662.63	6
Endurance Bed 0.0, Grey	7500GY	\$690.00	\$662.63	6
Endurance Bed 0.0, Sand	7500SD	\$690.00	\$662.63	6
Endurance Bed 0.0, Burgundy	7500BY	\$690.00	\$662.63	6
Endurance Bed 1.0, Black	7601BK	\$715.00	\$684.00	4

Endurance Bed 1.0, Slate Blue	7601SB	\$715.00	\$684.00	4
Endurance Bed 1.0, Green	7601GN	\$715.00	\$684.00	4
Endurance Bed 1.0, Brown	7601BN	\$715.00	\$684.00	4
Endurance Bed 1.0, Blue/Gray	7601BG	\$715.00	\$684.00	4
Endurance Bed 1.0, Grey	7601GY	\$715.00	\$684.00	4
Endurance Bed 1.0, Sand	7601SD	\$715.00	\$684.00	4
Endurance Bed 1.0, Burgundy	7601BY	\$715.00	\$684.00	4
Endurance Bed 2.0 Black	7801BK	\$830.00	\$815.00	3
Endurance Bed 2.0 Slate Blue	7801SB	\$830.00	\$815.00	3
Endurance Bed 2.0 Green	7801GN	\$830.00	\$815.00	3
Endurance Bed 2.0 Brown	7801BN	\$830.00	\$815.00	3
Endurance Bed 2.0 Blue/Gray	7801BG	\$830.00	\$815.00	3
Endurance Bed 2.0 Grey	7801GY	\$830.00	\$815.00	3
Endurance Bed 2.0 Sand	7801SD	\$830.00	\$815.00	3
Endurance Bed 2.0 Burgundy	7801BY	\$830.00	\$815.00	3
Endurance Bed 2.1 with side storage compartments Black	7802BK	\$1,100.00	\$1,075.00	3
Endurance Bed 2.1 with side storage compartments Slate Blue	7802SB	\$1,100.00	\$1,075.00	3
Endurance Bed 2.1 with side storage compartments Green	7802GN	\$1,100.00	\$1,075.00	3
Endurance Bed 2.1 with side storage compartments Brown	7802BN	\$1,100.00	\$1,075.00	3
Endurance Bed 2.1 with side storage compartments Blue/Gray	7802BG	\$1,100.00	\$1,075.00	3
Endurance Bed 2.1 with side storage compartments Gray	7802GY	\$1,100.00	\$1,075.00	3
Endurance Bed 2.1 with side storage compartments Sand	7802SD	\$1,100.00	\$1,075.00	3
Endurance Bed 2.1 with side storage compartments Burgundy	7802BY	\$1,100.00	\$1,075.00	3
Endurance Bed 2.2 no storage compartments Black	7803BK	\$830.00	\$815.00	3
Endurance Bed 2.2 no storage compartments Slate Blue	7803SB	\$830.00	\$815.00	3
Endurance Bed 2.2 no storage compartments Green	7803GN	\$830.00	\$815.00	3
Endurance Bed 2.2 no storage compartments Brown	7803BN	\$830.00	\$815.00	3
Endurance Bed 2.2 no storage compartments Blue/Gray	7803BG	\$830.00	\$815.00	3
Endurance Bed 2.2 no storage compartments Gray	7803GY	\$830.00	\$815.00	3

Endurance Bed 2.2 no storage compartments Sand	7803SD	\$830.00	\$815.00	3
Endurance Bed 2.2 no storage compartments Burgundy	7803BY	\$830.00	\$815.00	3
Restraint Rings for Endurance Bed and Endurance 2.0 Bed	302003	\$19.50		
Endurance Bed Riser for 2.0 Bed Black	7606BK	\$538.24	\$495.90	8
Endurance Bed Riser for 2.0 Bed Slate Blue	7606SB	\$538.24	\$495.90	8
Endurance Bed Riser for 2.0 Bed Green	7606GN	\$538.24	\$495.90	8
Endurance Bed Riser for 2.0 Bed Brown	7606BN	\$538.24	\$495.90	8
Endurance Bed Riser for 2.0 Bed Blue/Gray	7606BG	\$538.24	\$495.90	8
Endurance Bed Riser for 2.0 Bed Grey	7606GY	\$538.24	\$495.90	8
Endurance Bed Riser for 2.0 Bed Sand	7606SD	\$538.24	\$495.90	8
Endurance Bed Riser for 2.0 Bed Burgundy	7606BY	\$538.24	\$495.90	8
Blue Standard Correctional Mattress 4.5 x 25 x 75 w/integrated pillows	C452575P	\$94.90	\$94.90	1
Blue Standard Correctional Mattress 4.5 x 30 x 75 w/integrated pillows	C453075P	\$122.09	\$122.09	1
Blue Standard Correctional Mattress 4.5 x 35 x 75 w/integrated pillows	C453575P	\$129.35	\$129.35	1
SEG-MAX Correctional Mattress 4.5 x 30 x 75 w/integrated pillows	SEG453075P	\$262.61	\$262.61	1
SEG-MAX Correctional Mattress 4.5 x 35 x 75 w/integrated pillows	SEG453575P	\$269.88	\$269.88	1
See-clear-ity Correctional Mattress 3 x 25 x 75 no pillows	SEEMAT302575	\$140.50	\$140.50	1
Clear Vinyl Correctional Mattress 4.5 x 25 x 75 w/integrated pillow	CLR452575P	\$69.30	\$69.30	1
Clear Vinyl Correctional Mattress 4.5 x 30 x 75 w/integrated pillow	CLR453075P	\$83.16	\$83.16	1
Clear Vinyl Correctional Mattress 4.5 x 35 x 75 w/integrated pillow	CLR453575P	\$97.02	\$97.02	1
Standard Pinnacle 6 x 30 x 75	G603075	\$240.41	\$240.41	1
Standard Pinnacle 6 x 36 x 80	G603680	\$293.80	\$293.80	1
Pinnacle Plus 6 x 36x x 80 Rated for 250lbs +	G603680PLUS	\$300.59	\$300.59	1
Standard Pinnacle 6 x 39 x 80	G603980	\$382.14	\$382.14	1
Seg Max Pinnacle 6 x 30 x 75	SEG603075	\$376.64	\$376.64	1
Seg Max Pinnacle 6 x 36 x 80	SEG603680	\$439.95	\$439.95	1
Seg Max Pinnacle 6 x 39 x 81	SEG603980	\$453.27	\$453.27	1
EZ Gator Suit Suicide Smock	GATORSUIT	\$0.00	\$309.00	1
Endurance NightStand, Black	7602BK	\$220.00	\$196.65	16

Endurance NightStand, Slate Blue	7602SB	\$220.00	\$196.65	16
Endurance NightStand, Green	7602GN	\$220.00	\$196.65	16
Endurance NightStand, Brown	7602BN	\$220.00	\$196.65	16
Endurance NightStand, Blue Grey	7602BG	\$220.00	\$196.65	16
Endurance NightStand, Grey	7602GY	\$220.00	\$196.65	16
Endurance NightStand, Sand	7602SD	\$220.00	\$196.65	16
Endurance NightStand, Burgundy	7602BY	\$220.00	\$196.65	16
Endurance Desk, All plastic, Wall Mount Black	7605BK	\$425.00	\$403.99	6
Endurance Desk, All plastic, Wall Mount Grey	7605GY	\$425.00	\$403.99	6
Endurance Desk, All plastic, Wall Mount Slate Blue	7605SB	\$425.00	\$403.99	6
Endurance Desk, All plastic, Wall Mount Green	7605GN	\$425.00	\$403.99	6
Endurance Desk, All plastic, Wall Mount Brown	7605BN	\$425.00	\$403.99	6
Endurance Desk, All plastic, Wall Mount Blue Grey	7605BG	\$425.00	\$403.99	6
Endurance Desk, All plastic, Wall Mount Sand	7605SD	\$425.00	\$403.99	6
Endurance Desk, All plastic, Wall Mount Burgundy	7605BY	\$425.00	\$403.99	6
Endurance Desk, All plastic, Standing/floor Mount Black	7607BK	\$450.00	\$427.50	6
Endurance Desk, All plastic, Standing/floor Mount Grey	7607GY	\$450.00	\$427.50	6
Endurance Desk, All plastic, Standing/floor Mount Slate Blue	7607SB	\$450.00	\$427.50	6
Endurance Desk, All plastic, Standing/floor Mount Green	7607GN	\$450.00	\$427.50	6
Endurance Desk, All plastic, Standing/floor Mount Brown	7607BN	\$450.00	\$427.50	6
Endurance Desk, All plastic, Standing/floor Mount Blue Grey	7607BG	\$450.00	\$427.50	6
Endurance Desk, All plastic, Standing/floor Mount Sand	7607SD	\$450.00	\$427.50	6
Endurance Desk, All plastic, Standing/floor Mount Burgundy	7607BY	\$450.00	\$427.50	6
Endurance Wall 2 shelf, Black	7604BK	\$200.00	\$175.28	12
Endurance Wall 2 shelf, Grey	7604GY	\$200.00	\$175.28	12
Endurance Wall 2 shelf, Slate Blue	7604SB	\$200.00	\$175.28	12
Endurance Wall 2 shelf, Green	7604GN	\$200.00	\$175.28	12
Endurance Wall 2 shelf, Brown	7604BN	\$200.00	\$175.28	12
Endurance Wall 2 shelf, Blue Grey	7604BG	\$200.00	\$175.28	12

Endurance Wall 2 shelf, Sand	7604SD	\$200.00	\$175.28	12
Endurance Wall 2 shelf, Burgundy	7604BY	\$200.00	\$175.28	12
Endurance 4 shelf, Black	7101BK	\$380.00	\$342.00	8
Endurance 4 shelf, Grey	7101GY	\$380.00	\$342.00	8
Endurance 4 shelf, Slate Blue	7101SB	\$380.00	\$342.00	8
Endurance 4 shelf, Green	7101GN	\$380.00	\$342.00	8
Endurance 4 shelf, Brown	7101BN	\$380.00	\$342.00	8
Endurance 4 shelf, Blue Grey	7101BG	\$380.00	\$342.00	8
Endurance 4 shelf, Sand	7101SD	\$380.00	\$342.00	8
Endurance 4 shelf, Burgundy	7101BY	\$380.00	\$342.00	8
Endurance Chest, Black	7201BK	\$370.00	\$316.35	6
Endurance Chest, Grey	7201GY	\$370.00	\$316.35	6
Endurance Chest, Slate Blue	7201SB	\$370.00	\$316.35	6
Endurance Chest, Green	7201GN	\$370.00	\$316.35	6
Endurance Chest, Brown	7201BN	\$370.00	\$316.35	6
Endurance Chest, Blue Grey	7201BG	\$370.00	\$316.35	6
Endurance Chest, Sand	7201SD	\$370.00	\$316.35	6
Endurance Chest, Burgundy	7201BY	\$370.00	\$316.35	6
Endurance Stool, Black	7901BK	\$130.00	\$109.01	30
Endurance Stool, Grey	7901GY	\$130.00	\$109.01	30
Endurance Stool, Slate Blue	7901SB	\$130.00	\$109.01	30
Endurance Stool, Green	7901GN	\$130.00	\$109.01	30
Endurance Stool, Brown	7901BG	\$130.00	\$109.01	30
Endurance Stool, Blue Grey	7901BN	\$130.00	\$109.01	30
Endurance Stool, Sand	7901SD	\$130.00	\$109.01	30
Endurance Stool, Burgundy	7901BY	\$130.00	\$109.01	30
Clear Visitation Table 40" Round	CLR40	\$170.74	\$850.73	10
Endurance Table 42" Round X-Base Flame Retardant Black	66749BK	\$520.00	\$470.25	4
Endurance Table 42" Round X-Base Flame Retardant Blue Grey	66749BG	\$520.00	\$470.25	4
Endurance Table 42" Round X-Base Flame Retardant Green	66749GN	\$520.00	\$470.25	4
Endurance Table 42" Round X-Base Flame Retardant Grey	66749GY	\$520.00	\$470.25	4
Endurance Table 42" Round X-Base Flame Retardant Slate Blue	66749SB	\$520.00	\$470.25	4

Endurance Table 42' Round X-Base Flame Retardant Sand	66749SD	\$520.00	\$470.25	4
Endurance Table 42' Round X-Base Flame Retardant Brown	66749BN	\$520.00	\$470.25	4
Endurance Table 42' Round X-Base Flame Retardant Burgundy	66749BY	\$520.00	\$470.25	4
Endurance Table 42" Round X-Base Flame Retardant Brown Game Top	66749BNGT	\$580.00	\$534.38	4
Endurance Table 42" Round X-Base Flame Retardant Slate Blue Game Top	66749SBGT	\$580.00	\$534.38	4
Endurance Table 42" Square X-Base Flame Retardant Black	66750BK	\$550.00	\$500.00	4
Endurance Table 42" Square X-Base Flame Retardant Blue Grey	66750BG	\$550.00	\$500.00	4
Endurance Table 42" Square X-Base Flame Retardant Green	66750GN	\$550.00	\$500.00	4
Endurance Table 42" Square X-Base Flame Retardant Grey	66750GY	\$550.00	\$500.00	4
Endurance Table 42' Square X-Base Flame Retardant Slate Blue	66750SB	\$550.00	\$500.00	4
Endurance Table 42" Square X-Base Flame Retardant Sand	66750SD	\$550.00	\$500.00	4
Endurance Table 42" Square X-Base Flame Retardant Burgundy	66750BY	\$550.00	\$500.00	4
Endurance Table 42' Square X-Base Flame Retardant Brown	66750BN	\$550.00	\$500.00	4
Endurance Table 42" Square X-Base Flame Retardant Brown Game Top	66750BNGT	\$600.00	\$575.00	4
Endurance Table 42" Square X-Base Flame Retardant Slate Blue Game Top	66750SBGT	\$600.00	\$575.00	4
Endurance Table 48" Round X-Base Flame Retardant Black	66751BK	\$615.00	\$584.27	6
Endurance Table 48" Round X-Base Flame Retardant Blue Grey	66751BG	\$615.00	\$584.27	6
Endurance Table 48" Round X-Base Flame Retardant Green	66751GN	\$615.00	\$584.27	6
Endurance Table 48" Round X-Base Flame Retardant Grey	66751GY	\$615.00	\$584.27	6
Endurance Table 48' Round X-Base Flame Retardant Slate Blue	66751SB	\$615.00	\$584.27	6
Endurance Table 48' Round X-Base Flame Retardant Sand	66751SD	\$615.00	\$584.27	6
Endurance Table 48' Round X-Base Flame Retardant Brown	66751BN	\$615.00	\$584.27	6
Endurance Table 48' Round X-Base Flame Retardant Burgundy	66751BY	\$615.00	\$584.27	6
Endurance Table 48" Round X-Base Flame Retardant Brown Game Top	66751BNGT	\$700.00	\$641.25	6
Endurance Table 48" Round X-Base Flame Retardant Slate Blue Game Top	66751SBGT	\$700.00	\$641.25	6

STATE OF MICHIGAN

Contract No. 20000000373
Statewide – Anti-Ligature Furnishing Services

SCHEDULE C PRODUCT SPECIFICATIONS

Michigan Department of Health and Human Services (MDHHS) Hospitals:

1. Caro Center
 - a. 2000 Chambers Road, Caro, MI 48723
2. Center for Forensic Psychiatry (CFP)
 - a. 8303 Platt Road, Saline, MI 48176
3. Hawthorn Center
 - a. 18471 Haggerty Road, Northville, MI 48167
4. Kalamazoo Psychiatric Hospital (KPH)
 - a. 1312 Oakland Drive, Kalamazoo, MI 49008
5. Walter Reuther Psychiatric Hospital (WRPH)
 - a. 30901 Palmer Road, Westland, MI 48186

Additional MDHHS Facility:

1. Juvenile Justice Residential (JJB) Facility
 - a. Bay pines Center
 - i. 2425 N 30th Street, Escanaba, MI 49829
 - b. Shawono Center
 - i. 10 N Howes Lake Road, Grayling, MI 49738

BJJ Centers:

- Bay Pines Center
- Shawono Center

Please note the following items are a general list of items currently utilized, items listed are an indicator of future need and are in no way a guarantee of items to be purchased by the State in the future.

In Section 1.1 Product Specifications, of Schedule A – Statement of Work, please confirm that items offered by your Organization will meet the minimum requirements show below.

Special Notes:

1. Classroom furnishings must be youth appropriate for high security residential living.
2. Classroom furnishings must allow for arrangement around the parameter of the room, to allow for the teachers' station to have no youth desk to their back.
3. It is preferred that desks/workstations be adjustable and are movable with locking wheels If applicable.
4. Desks/workstations must be made of materials that not breakable, that can withstand hitting, kicking and other means of force, or easily throw.
5. Desks/workstations cannot have components, pieces or parts that can be removed easily, taken or broken off.
6. Each desk/workstation should have some a partition/divider on the underneath to prevent physical contact from another desk/workstation.
7. The following products must be new, fire-retardant polyethylene; the following are anticipated items for purchase:
 - a. Classroom – Seating, Chairs
 - b. Classroom Seating, Desks
 - c. Classroom Teachers Desk

Caro Center:

Please note the following items are a general list of items currently utilized, items listed are an indicator of future need and are in no way a guarantee of items to be purchased by the State in the future.

In Section 1.1 Product Specifications, of Schedule A – Statement of Work, please confirm that items offered by your Organization will meet the minimum requirements show below.

Special Notes:

1. Beds and Dining Room Tables must have the capability of being fixed to the floor.
2. If special equipment/processes are required to fix furnishing to the floor, please indicate how the State can obtain required equipment/process for proper installation. It is preferred that items for purchase are able to be installed by the facilities Maintenance Department.
3. The following products must be new, fire-retardant polyethylene; the following are anticipated items for purchase:
 - a. Patient Unit Beds: 41"x86x24" or; 40"x83.5x15.5"
 - b. Patient Unit Open Chest: 26"Wx24"Dx78&3/8"H
 - c. Patient Unit Wardrobes: 26"x25½ "Dx 78&3/8"H

Center for Forensic Psychiatry:

Please note the following items are a general list of items currently utilized, items listed are an indicator of future need and are in no way a guarantee of items to be purchased by the State in the future.

In Section 1.1 Product Specifications, of Schedule A – Statement of Work, please confirm that items offered by your Organization will meet the minimum requirements show below.

Special Notes:

1. Wardrobes do not currently have doors.
2. Beds including bedroom furnishings, and chairs do not have to be bolted to the floor.
3. Dayroom chairs will be a mix of chairs with and without arms.
4. The following products must be new, fire-retardant polyethylene; the following are anticipated items for purchase:
 - a. Padded Arm and armless chairs
 - b. Patient Unit Beds: 84"L x 40"W x 15 1/2"H
 - c. Patient Unit Desks: 36"Wx29Hx24"D
 - d. Patient Unit Armless Chair – nonpadded
 - e. Patient Unit Open Chest: 30"Wx42&7/8"Hx 18"D
 - f. Patient Unit Wardrobe
 - i. No Door: 26"Wx24"Dx73"H
 - ii. With Door: 26"Wx25"Dx78"H

Hawthorn Center:

Please note the following items are a general list of items currently utilized, items listed are an indicator of future need and are in no way a guarantee of items to be purchased by the State in the future.

In Section 1.1 Product Specifications, of Schedule A – Statement of Work, please confirm that items offered by your Organization will meet the minimum requirements shown below.

Special Notes:

1. Living Areas/TV Room chairs are a mix of chairs with and without arms. (40 of each chair style approximately)
2. Beds should be in the following styles: Platform, Rimmed Edge – to retain fluids, fixed and sealed to the floor. (56 of each bed style) No build in cubbies are permitted.
3. Wardrobes must be ligature resistant with locking door, fold flat hinges, and built in shelves.
4. Room Desks must be ligature resistant and 36" tall.
5. All items listed above 1-4 are plastic, sealed seams, rounded corners, and fire resistant. All Patient living area furniture must have impermeable surfaces for cleaning, and sanitizing.
6. Classroom Furniture: individual student desks – need chair attached to work surface. Cafeteria Seating: 4 or 8-person table with fixed chair or seat.
7. All items provided must be new, Fire-Retardant Polyethylene

Kalamazoo Psychiatric Hospital (KPH):

Please note the following items are a general list of items currently utilized, items listed are an indicator of future need and are in no way a guarantee of items to be purchased by the State in the future. In Section 1.1 Product Specifications, of Schedule A – Statement of Work, please confirm that items offered by your Organization will meet the minimum requirements show below.

Special Notes:

1. All Patient living area furniture must have impermeable surface for cleaning and sanitizing to address infection control concerns.
2. Day room Chairs are to be ligature resistant (Anti-ligature) capacity to hold up to 350 lbs, not able to be easily picked up/thrown, soft seats for adult patients with medical issues.
3. Day room and unit dining room chairs can be with and/or without arms and/or rockers, and ability to be bolted to the floor.
4. Dining room Chairs are to be ligature resistant (Anti-ligature) capacity to hold up to 350 lbs, not able to be easily picked up/thrown, soft seats for adult patients with medical issues.
5. All Patient living area furniture must have impermeable surface for cleaning and sanitizing to address infection control concerns.
6. Beds, and bedroom furnishing must be bolted on an as needed basis. Hospital and prison beds are ordered on an as needed basis.
7. The following products must be new, fire-retardant polyethylene; the following are anticipated items for purchase:
 - a. Patient Unit – Beds: 36"x80" with under bed storage shelving
 - b. Patient Unit Fall Risk – Bed: 36"x82"x8"
 - c. Hospital Bed: Generally: 41.5'x8'x8 – height can vary
 - d. Prison Bed: 38"x82"x11
 - e. Patient Unit Wardrobes: 36"x78x24" or; 26"x75"x24
 - f. Cabinets: varying dimensions
 - g. Property Boxes: 2cu. Ft. 23"x11.5"x18"
 - h. Razorback chair: 19"x19"x29.5"
 - i. Saber Chair: 30"x30"x32"
 - j. Game Tables: 42"x42"x29"

Walter Reuther Psychiatric Hospital (WRPH):

Please note the following items are a general list of items currently utilized, items listed are an indicator of future need and are in no way a guarantee of items to be purchased by the State in the future.

In Section 1.1 Product Specifications, of Schedule A – Statement of Work, please confirm that items offered by your Organization will meet the minimum requirements show below.

Special Notes:

1. Patient Living Area Chairs – rounded backs and seats, seats must be appropriate for large adult patients with medical issues, with a weight capacity of 350lbs.
 - a. Steel seats pan to conceal nay staples/tamper proof screws.
 - b. Chair base constructed with sled style legs with floor protective glides
 - c. Chairs can be with or without arms
2. All metal products must be constructed with minimum 14-gauge oval steel.
3. Seating materials must contain a moisture barrier, high grade vinyl and other anti-microbial material options.
4. Furniture must be freestanding.
5. The following products must be new, fire-retardant polyethylene; the following are anticipated items for purchase:
 - a. Patient Are Chairs: 25"-28" seat
 - b. Patient Dining Area Chairs: 25"-28" seat
 - c. Dining Area Table – TBD

STATE OF MICHIGAN

Contract No. 200000000373
Statewide – Anti-Ligature Furnishing Services

SCHEDULE D
Vendor Products – Endurance
Please Refer to Pages 39 – 71

The Endurance Standing Desk



29H x 36W x 24D

- Size: 29"H x 36"W x 24"D
- One piece rotatorially molded polyethylene material / No steel or wood components
- Can be bolted to the wall, floor, or both with concealed mounting holes
- Flame Retardant (passes Cal 133) / Foam used to ensure a level writing surface
- Virtually unbreakable / 10 year warranty / Stain resistant
- Owner specified color from 7 standard options

FEATURES:

- Durable, one piece, rotatorially molded design for increased strength. Constructed of high impact "no break" polyethylene. No steel or wood components with all plastic desk.
- Stain resistant.
- Easy to clean and maintain.
- Bolt to the floor via concealed pilot holes with hardware of your choice.
- Flame Retardant (passes Cal 133). Test reports available upon request.
- Manufactured to ISO Quality Standards in the USA. 



Chair sold separately.



Custom colors available upon request. Call Cortech for details.

ITEM	DESCRIPTION
7607BK	Black FR
7607BG	Blue Gray FR
7607BN	Brown FR
7607GN	Green FR
7607GY	Gray FR
7607SB	Slate Blue FR
7607SD	Sand FR

Ideal For Use In: Correctional Facilities, Behavioral/Mental Health Facilities & Law Enforcement/Security.

OVERVIEW

The Endurance Standing Desk is a versatile, heavy duty, desk that is ideal for continuous, intensive use in correctional or institutional environments. **Manufactured to ISO Quality Standards in the USA.**

FABRICATION/MATERIAL

Durable, one piece, rotationally molded design for increased strength. Constructed of high impact polyethylene. No steel or wood components. Flame Retardant (as shown passes Cal 133). Test reports available upon request.

COLOR See Chart, custom colors available upon request.

WEIGHT 35 lbs.

OPTIONS N/A

ASSEMBLY Bolt to the floor or wall via concealed pilot holes with hardware of your choice.

WARRANTY 10 Year Warranty.

MAINTENANCE Easy to clean and maintain with damp cloth. Resistant to stains.

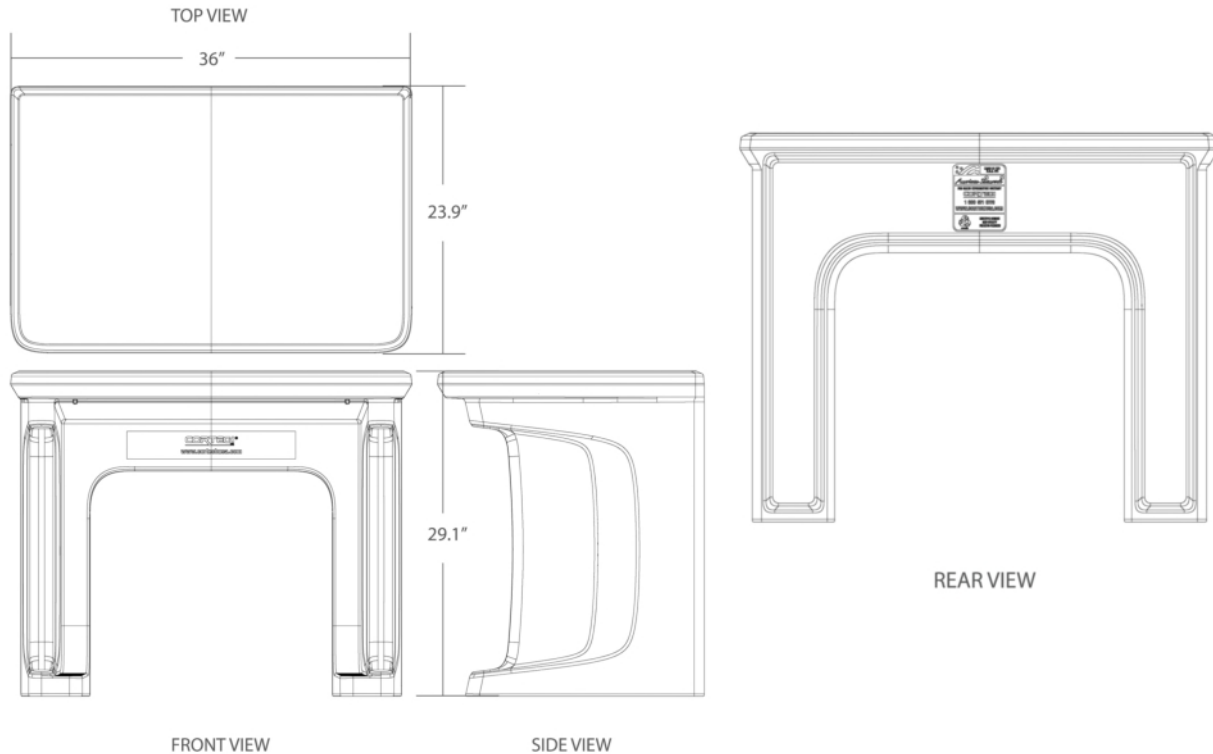

The Endurance Wall Mount Desk 2.0 (All Plastic)



All Plastic

**10 Year
Warranty**

29H x 36W x 24D

- 29”H x 36”W x 24”D
- One piece rotationally molded polyethylene material / No steel or wood components
- Can be bolted to the wall with concealed mounting holes
- Flame Retardant (passes Cal 133) / Foam used to ensure a level writing surface
- Virtually unbreakable / 10 year warranty / Stain resistant
- Owner specified color from 7 standard options



*Optional smooth
laminate top*

FEATURES:

- Durable, one piece, rotationally molded design for increased strength. Constructed of high impact “no break” polyethylene. No steel or wood components with all plastic desk.
- Stain resistant.
- Easy to clean and maintain.
- Bolt to the floor and wall via concealed pilot holes with hardware of your choice.
- Flame Retardant (passes Cal 133). Test reports available upon request.
- Manufactured to ISO Quality Standards in the USA.

ITEM	DESCRIPTION
7605BK	Black FR
7605BG	Blue Gray FR
7605BN	Brown FR
7605GN	Green FR
7605GY	Gray FR
7605SB	Slate Blue FR
7605SD	Sand FR



Custom colors available upon request. Call Cortech for details.

Ideal For Use In: Correctional Facilities, Behavioral/Mental Health Facilities & Law Enforcement/Security.

Our Intense Use and Correctional Specific products contribute to a safe and humane environment.
For Full Specifications Call Toll Free 800-571-0770 / Fax: 630-455-0813 / or Visit www.cortechusa.com

OVERVIEW

The Endurance Desk 2.0 is a versatile, heavy duty desk that is ideal for continuous, intensive use in correctional or institutional environments. **Manufactured to ISO Quality Standards in the USA.**

FABRICATION/MATERIAL

Durable, one piece, rotationally molded design for increased strength. Constructed of high impact polyethylene. No steel components. Flame Retardant (as shown passes Cal 133). Test reports available upon request.

COLOR See Chart, custom colors available upon request.

WEIGHT 35 lbs.

OPTIONS N/A

ASSEMBLY Bolt to the floor and wall via concealed pilot holes with hardware of your choice.

WARRANTY 10 Year Warranty.

MAINTENANCE Easy to clean and maintain with damp cloth. Resistant to stains.

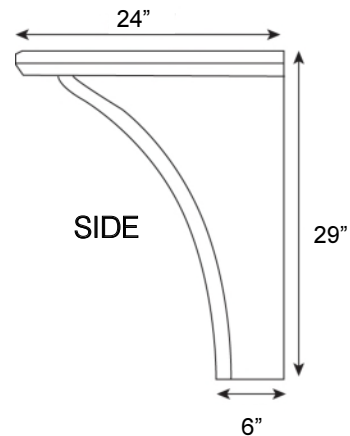
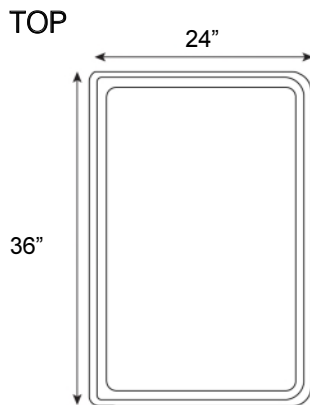
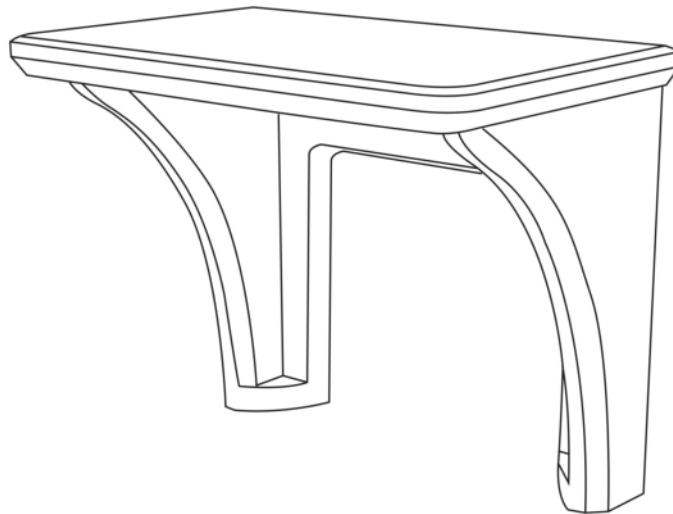

The Endurance Open Chest



42H x 30W x 18D

**10 Year
Warranty**

- Size: 30" W x 18" D x 42" H
- One piece rotationally molded polyethylene material / No steel or wood components / No foam
- Can be bolted to the floor with concealed mounting holes
- Flame Retardant (passes Cal 133)
- Virtually unbreakable / 10 year warranty / Stain resistant
- Owner specified color from 7 standard options

FEATURES:

- Molded in shelving for open storage of personal items.
- Durable, one piece, rotationally molded design for increased strength. Constructed of high impact "no break" polyethylene. No steel or wood components.
- Stain resistant.
- Bolt to the wall or floor via concealed pilot holes with hardware of your choice.
- Easy to clean and maintain.
- Flame Retardant (passes Cal 133). Test reports available upon request.
- Manufactured to ISO Quality Standards in the USA. 

ITEM	DESCRIPTION
7201BK	Black FR
7201BG	Blue Gray FR
7201BN	Brown FR
7201GN	Green FR
7201GY	Gray FR
7201SB	Slate Blue FR
7201SD	Sand FR



Custom colors available upon request. Call Cortech for details.

Ideal For Use In: Correctional Facilities, Behavioral/Mental Health Facilities & Law Enforcement/Security.

Our Intense Use and Correctional Specific products contribute to a safe and humane environment. For Full Specifications Call Toll Free 800-571-0770 / Fax: 630-455-0813 / or Visit www.cortechusa.com

OVERVIEW

The Endurance Open Chest is a versatile, heavy duty stand for open storage and is ideal for continuous, intensive use in correctional or institutional environments. **Manufactured to ISO Quality Standards in the USA.**

FABRICATION/MATERIAL

Durable, one piece, rotationally molded design for increased strength. Constructed of high impact polyethylene. No steel or wood components. Flame Retardant (as shown passes Cal 133). Test reports available upon request.

COLOR See Chart, custom colors available upon request.

WEIGHT 58 lbs

OPTIONS N/A

ASSEMBLY Bolt to the wall via concealed pilot holes with hardware of your choice.

WARRANTY 10 Year Warranty.

MAINTENANCE Easy to clean and maintain with damp cloth. Resistant to stains.

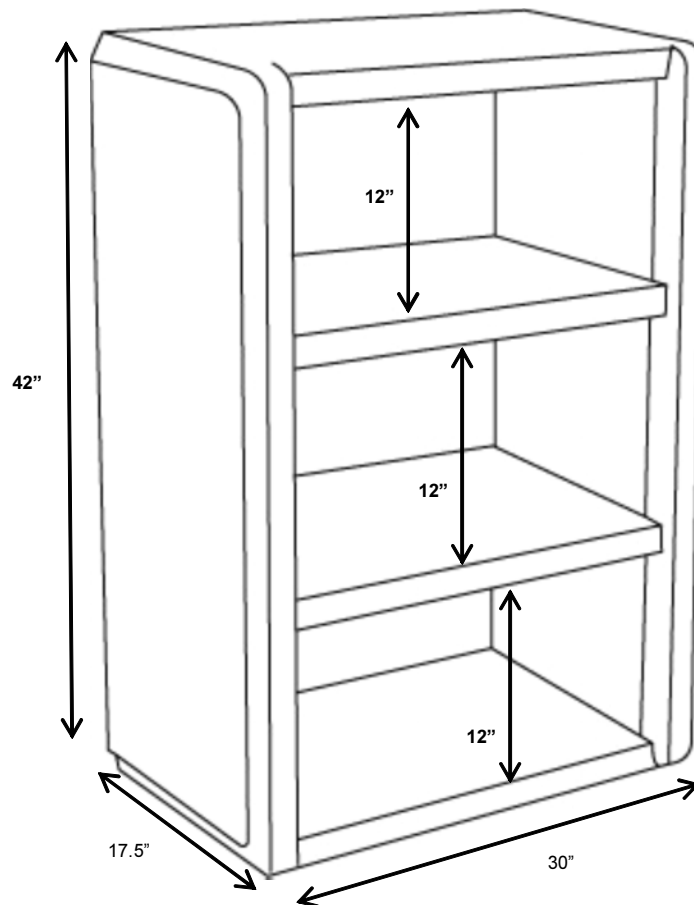

The Endurance Round Top Table

It has an EXTREME load capacity due to its rotational molding technology and the rounded table top edge increases safety and comfort, making it ideal for food service, as well as, recreational applications.



10 Year Warranty

29H x 42W x 42D

- Size: 42" W x 42" D x 29" H / Table top size: 42" round
- The legs affix to the table top with tamper resistant screws / Legs can be easily filled with sand to weigh down
- Table tops and legs are rotationally molded polyethylene material / Game top optional
- Can be bolted to the floor with concealed mounting holes
- Flame Retardant (passes Cal 133)
- Virtually unbreakable / 10 year warranty / Stain resistant
- Owner specified color from 7 standard options



Game Top

FEATURES:

- Table top size: 42" round
- Can be bolted to the floor via concealed pilot holes with our exclusive Sabre Mount System.
- The legs affix to the table top with tamper resistant screws.
- Table top and legs are made with durable, one piece, rotationally molded design for increased strength. Constructed of high impact polyethylene.
- Resistant to stains.
- Easy to clean and maintain.
- Legs can be easily filled with sand to weigh down.
- Flame Retardant (passes Cal 133). Test reports available upon request.
- Manufactured to ISO Quality Standards in the USA.



Custom colors available upon request. Call Cortech for details.

ITEM	SIZE	COLOR
66749BK	42" Round	Black
66749BG	42" Round	Blue Gray
66749BN	42" Round	Brown
66749GN	42" Round	Green
66749GY	42" Round	Gray
66749SB	42" Round	Slate Blue
66749SD	42" Round	Sand

ITEM	SIZE	COLOR
66749BNGT	42" Round Game Top	Brown
66749SBGT	42" Round Game Top	Slate Blue

Ideal For Use In: Correctional Facilities, Behavioral/Mental Health Facilities & Law Enforcement/Security.

Our Intense Use and Correctional Specific products contribute to a safe and humane environment. For Full Specifications Call Toll Free 800-571-0770 / Fax: 630-455-0813 / or Visit www.cortechusa.com

OVERVIEW

The Endurance Table is a versatile, heavy duty table that is ideal for continuous, intensive use in correctional or institutional environments. **Manufactured to ISO Quality Standards in the USA.**

FABRICATION/MATERIAL

Table top and legs are made with durable, one piece, rotationally molded design for increased strength. Constructed of high impact polyethylene. Flame Retardant (as shown passes Cal 133). Test reports available upon request.

COLOR See Chart, custom colors available upon request.

WEIGHT 55 lbs

OPTIONS Plain Top and Game Top.

ASSEMBLY The legs affix to the table top with tamper resistant screws. Can be bolted to the floor via concealed pilot holes with our exclusive **Sabre Mount System**.

WARRANTY 10 Year Warranty.

MAINTENANCE Easy to clean and maintain with damp cloth. Resistant to stains.

STATIC LOAD 1500 lbs.

FRONT

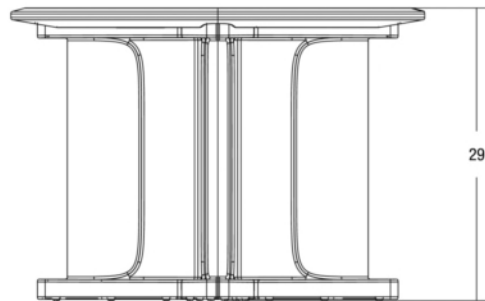

ROUND TOP

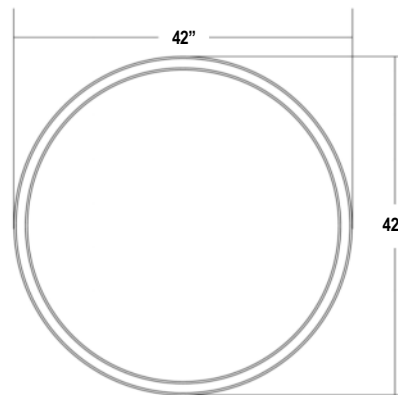

The Endurance 48" Round Top Table

It has an EXTREME load capacity due to its rotational molding technology and the rounded table top edge increases safety and comfort, making it ideal for food service, as well as, recreational applications.



**10 Year
Warranty**

29"H x 48" Diameter

- Size: 48" W x 48" D x 29" H / Table top size: 48" round
- The legs affix to the table top with tamper resistant screws / Legs can be easily filled with sand to weigh down
- Table tops and legs are rotationally molded polyethylene material / Game top optional
- Can be bolted to the floor with concealed mounting holes
- Flame Retardant (passes Cal 133)
- Virtually unbreakable / 10 year warranty / Stain resistant
- Owner specified color from 7 standard options



Game Top

FEATURES:

- Table top size: 48" round
- Can be bolted to the floor via concealed pilot holes with our exclusive Sabre Mount System.
- The legs affix to the table top with tamper resistant screws.
- Table top and legs are made with durable, one piece, rotationally molded design for increased strength. Constructed of high impact polyethylene.
- Resistant to stains.
- Easy to clean and maintain.
- Legs can be easily filled with sand to weigh down.
- Flame Retardant (passes Cal 133). Test reports available upon request.
- Manufactured to ISO Quality Standards in the USA.



Custom colors available upon request. Call Cortech for details.

ITEM	SIZE	COLOR
66751BK	48" Round	Black
66751BG	48" Round	Blue Gray
66751BN	48" Round	Brown
66751GN	48" Round	Green
66751GY	48" Round	Gray
66751SB	48" Round	Slate Blue
66751SD	48" Round	Sand
ITEM	SIZE	COLOR
66751BNGT	48" Round Game Top	Brown
66751SBGT	48" Round Game Top	Slate Blue

Ideal For Use In: Correctional Facilities, Behavioral/Mental Health Facilities & Law Enforcement/Security.

Our Intense Use and Correctional Specific products contribute to a safe and humane environment. For Full Specifications Call Toll Free 800-571-0770 / Fax: 630-455-0813 / or Visit www.cortechusa.com

OVERVIEW

The Endurance Table is a versatile, heavy duty table that is ideal for continuous, intensive use in correctional or institutional environments. **Manufactured to ISO Quality Standards in the USA.**

FABRICATION/MATERIAL

Table top and legs are made with durable, one piece, rotationally molded design for increased strength. Constructed of high impact polyethylene. Flame Retardant (as shown passes Cal 133). Test reports available upon request.

COLOR See Chart, custom colors available upon request.

WEIGHT 61 lbs

OPTIONS Plain Top and Game Top.

ASSEMBLY The legs affix to the table top with tamper resistant screws. Can be bolted to the floor via concealed pilot holes with our exclusive **Sabre Mount System**.

WARRANTY 10 Year Warranty.

MAINTENANCE Easy to clean and maintain with damp cloth. Resistant to stains.

STATIC LOAD 1500 lbs.

FRONT

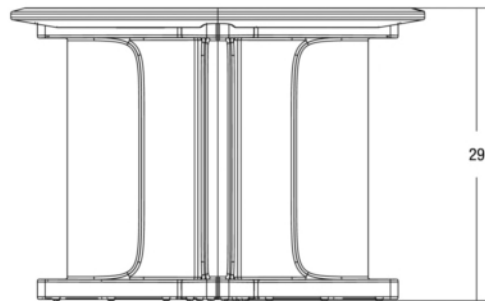

ROUND TOP

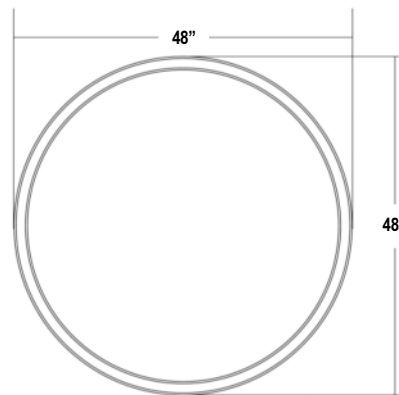

The Endurance Square Top Table

It has an EXTREME load capacity due to its rotational molding technology and the rounded table top edge increases safety and comfort, making it ideal for food service, as well as, recreational applications.

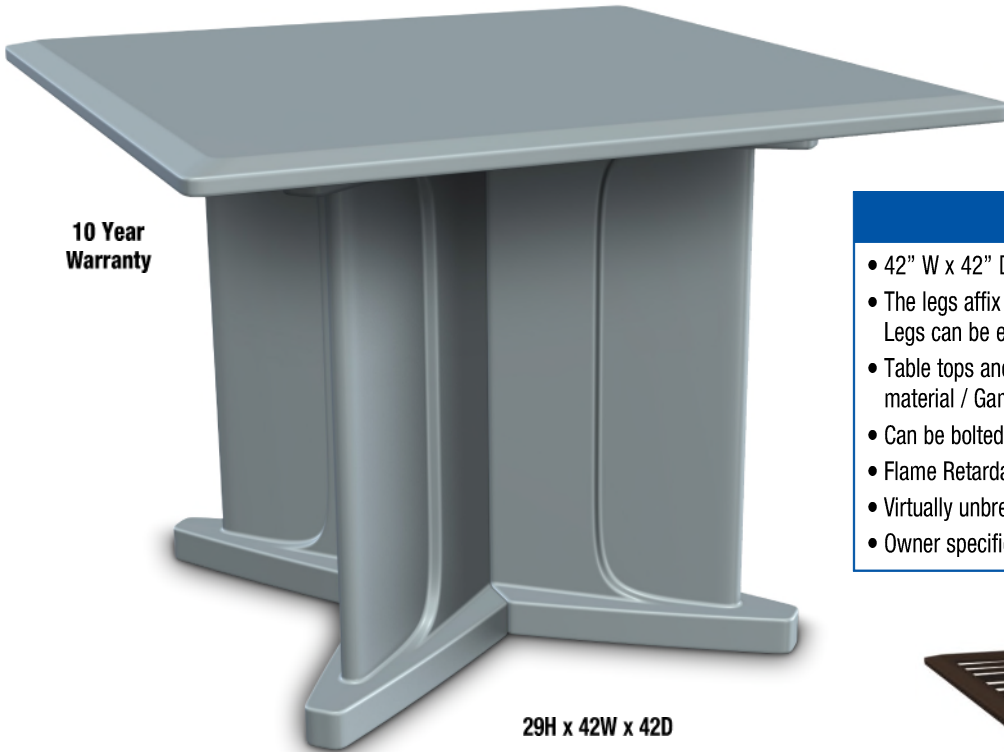



- 42" W x 42" D x 29" H / Table top size: 42" square
- The legs affix to the table top with tamper resistant screws / Legs can be easily filled with sand to weigh down
- Table tops and legs are rotationally molded polyethylene material / Game top optional
- Can be bolted to the floor with concealed mounting holes
- Flame Retardant (passes Cal 133)
- Virtually unbreakable / 10 year warranty / Stain resistant
- Owner specified color from 7 standard options



FEATURES:

- Table top size: 42" square
- Can be bolted to the floor via concealed pilot holes with our exclusive Sabre Mount System.
- The legs affix to the table top with tamper resistant screws.
- Table top and legs are made with durable, one piece, rotationally molded design for increased strength. Constructed of high impact polyethylene.
- Resistant to stains.
- Easy to clean and maintain.
- Legs can be easily filled with sand to weigh down.
- Flame Retardant (passes Cal 133). Test reports available upon request.
- Manufactured to ISO Quality Standards in the USA.

Available in

						
Black	Blue Gray	Brown	Green	Gray	Slate Blue	Sand

Custom colors available upon request. Call Cortech for details.

ITEM	SIZE	COLOR
66750BK	42" Square	Black
66750BG	42" Square	Blue Gray
66750BN	42" Square	Brown
66750GN	42" Square	Green
66750GY	42" Square	Gray
66750SB	42" Square	Slate Blue
66750SD	42" Square	Sand

ITEM	SIZE	COLOR
66750BNGT	42" Square Game Top	Brown
66750SBGT	42" Square Game Top	Slate Blue

Ideal For Use In: Correctional Facilities, Behavioral/Mental Health Facilities & Law Enforcement/Security.

OVERVIEW

The Endurance Table is a versatile, heavy duty table that is ideal for continuous, intensive use in correctional or institutional environments. **Manufactured to ISO Quality Standards in the USA.**

FABRICATION/MATERIAL

Table top and legs are made with durable, one piece, rotationally molded design for increased strength. Constructed of high impact polyethylene. Flame Retardant (as shown passes Cal 133). Test reports available upon request.

COLOR See Chart, custom colors available upon request.

WEIGHT 55 lbs

OPTIONS Plain Top and Game Top.

ASSEMBLY The legs affix to the table top with tamper resistant screws. Can be bolted to the floor via concealed pilot holes with our exclusive **Sabre Mount System**.

WARRANTY 10 Year Warranty.

MAINTENANCE Easy to clean and maintain with damp cloth. Resistant to stains.

STATIC LOAD 1500 lbs.

FRONT

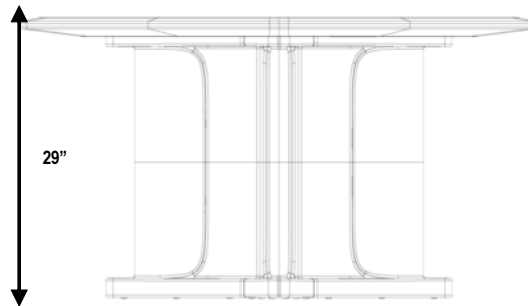

SQUARE TOP

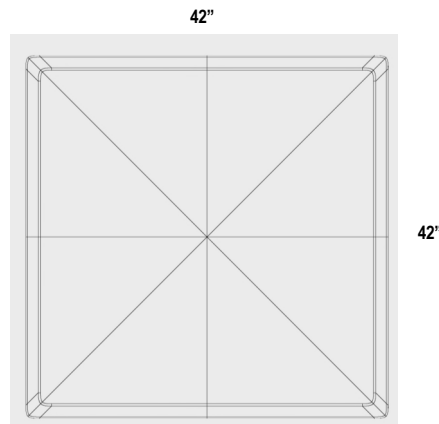

The Endurance X Series Laminate Tables

They are versatile, heavy duty tables that are ideal for continuous, intensive use in extreme environments and meets ADA requirements. All of The Endurance X Series Tables have an EXTREME load capacity and the rounded table top edge increases safety and comfort, making it ideal for use as Dayroom/Dining table applications.



- Square top size: 36"x36", 42"x42", 29" H
- Round top size: 42" Round, 48" Round, 29" H
- One piece rotationally molded polyethylene table base and round top.
- Two piece "X" base slide together and bolts to top with tamperproof screws.
- Virtually unbreakable / Stain resistant.
- Can be bolted to the floor with concealed mounting holes.
- Cal 133 Flame retardant.
- Owner specified color from 7 standard color options

FEATURES:

- Laminate Top is seamless one-piece design with EXTREME surface strength and impact resistance.
- Rounded edge for increase safety and comfort.
- Attached to legs with tamper-resistant screws.
- Is easy to clean and maintain.
- Manufactured to ISO Quality Standards in the USA.



*Warranty valid on manufacturing defects only.

- The legs are fastened to the top using tamper-resistant screws with metal to metal connection for added strength and durability.
- Can be bolted to the floor via concealed pilot holes with our exclusive Sabre Mount System.
- Legs are made with durable, one piece, rotationally molded design for increased strength. Constructed of high impact polyethylene.
- Legs can be easily filled with sand to weigh down.

ITEM	DESCRIPTION	WEIGHT (LBS.)
36SDPX	Table- 36"x36" Square Dura-Edge Plain-Top Xbase-Legs	77
36SVPX	Table- 36"x36" Square Vinyl-Edge Plain-Top Xbase-Legs	77
36SDGX	Table- 36"x36" Square Dura-Edge Game-Top Xbase-Legs	77
36SVGX	Table- 36"x36" Square Vinyl-Edge Game-Top Xbase-Legs	77
42RDPX	Table- 42" Round Dura-Edge Plain-Top Xbase-Legs	91
42RVPX	Table- 42" Round Vinyl-Edge Plain-Top Xbase-Legs	91
42SDPX	Table- 42"x42" Square Dura-Edge Plain-Top Xbase-Legs	102
42SVPX	Table- 42"x42" Square Vinyl-Edge Plain-Top Xbase-Legs	102
42SDGX	Table- 42"x42" Square Dura-Edge Game-Top Xbase-Legs	102
42SVGX	Table- 42"x42" Square Vinyl-Edge Game-Top Xbase-Legs	102
48RDPX	Table- 48" Round Dura-Edge Plain-Top Xbase-Legs	102
48RVPX	Table- 48" Round Vinyl-Edge Plain-Top Xbase-Legs	102
48RDGX	Table- 48" Round Dura-Edge Game-Top Xbase-Legs	102
48RVGX	Table- 48" Round Vinyl-Edge Game-Top Xbase-Legs	102

XBase is black. Plain table tops are gray. Game tops are white.

Ideal For Use In: Correctional Facilities, Behavioral/Mental Health Facilities & Law Enforcement/Security.

OVERVIEW

The Endurance Table is a versatile, heavy duty table that is ideal for continuous, intensive use in correctional or institutional environments. **Manufactured to ISO Quality Standards in the USA.**

FABRICATION/MATERIAL

Laminate Top is seamless one-piece design with EXTREME surface strength and impact resistance. Rounded edge for increase safety and comfort. Attached to legs with tamper-resistant screws. Flame Retardant (as shown passes Cal 133). Test reports available upon request.

XBASE FEATURES: The legs are fastened to the top using tamper-resistant screws with metal to metal connection for added strength and durability. Can be bolted to the floor via concealed pilot holes with our exclusive Sabre Mount System. Legs are made with durable, one piece, rotationally molded design for increased strength. Constructed of high impact polyethylene. Legs can be easily filled with sand to weigh down.

COLOR See chart on front page, custom colors available upon request.

WEIGHT See chart.

OPTIONS Plain Top and Game Top. Dura-Edge or Vinyl Edge.

ASSEMBLY The legs affix to the table top with tamper resistant screws. Can be bolted to the floor via concealed pilot holes with our exclusive **Sabre Mount System**.

WARRANTY 10 Year Warranty.

MAINTENANCE Easy to clean and maintain with damp cloth. Resistant to stains.

STATIC LOAD 1500 lbs.

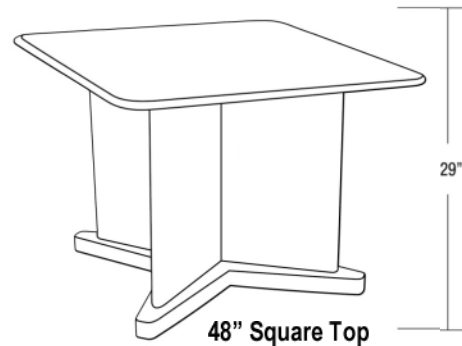
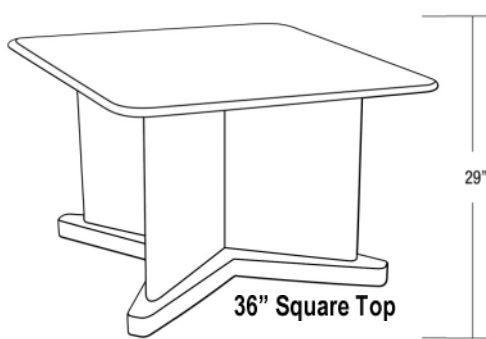

The Sabre Chair

It has an EXTREME load capacity and designed to stand alone or be ganged together. The ergonomic design provides maximum comfort using rotational molding technology.

**10 Year
Warranty**

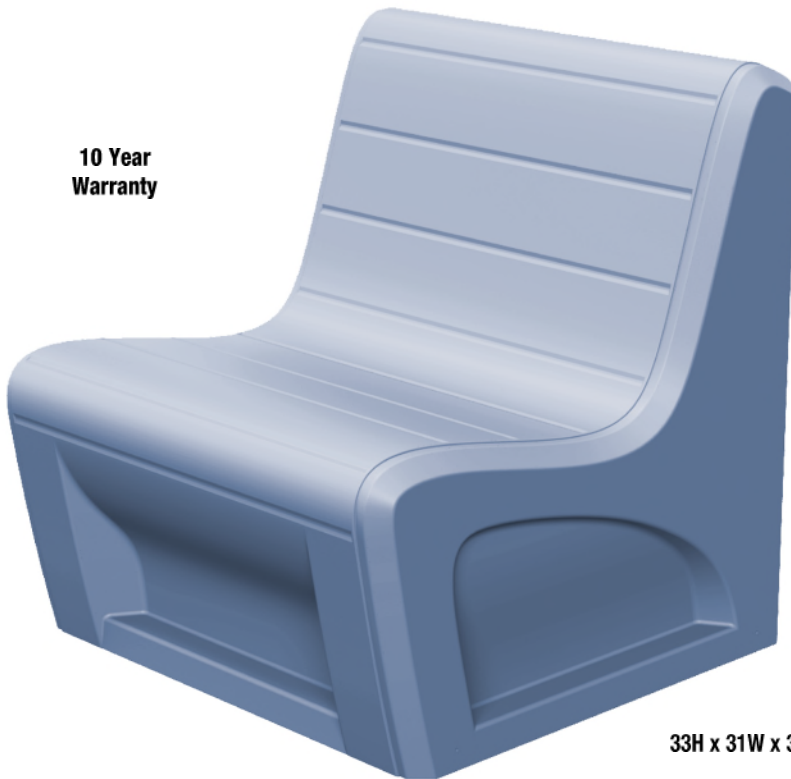

33H x 31W x 32D

- 31" W x 32" D x 33" H
- Durable, one piece, rotationally molded polyethylene lounge chair
- Can be bolted to the floor with concealed mounting holes or ganged together for groupings
- Optional tamperproof backside sand bag ballast port for easy safety weighting
- Flame Retardant (passes Cal 133), 1,500 pound static load tested
- Virtually unbreakable / 10 year warranty / Stain resistant
- Owner specified color from 7 standard options



ITEM	DESCRIPTION
96484BK	Black
96484BG	Blue Gray
96484BN	Brown
96484GN	Green
96484GY	Gray
96484SB	Slate Blue
96484SD	Sand

FEATURES:

- Durable, one piece, rotationally molded design for increased strength. Constructed of high impact "no break" polyethylene. No steel or wood components.
- Can be used alone or be ganged together.
- Can be bolted together, in place, as well as to the floor via concealed pilot holes.
- Resistant to stains.
- Can be easily filled with sand through optional ballast door on site to weigh down. Secures with tamperproof screws.
- Easy to clean and maintain.
- Flame Retardant (passes Cal 133). Test reports available upon request.
- Manufactured to ISO Quality Standards in the USA.



Custom colors available upon request. Call Cortech for details.

ITEM	DESCRIPTION
96484BKS	Black with Access Door
96484BGS	Blue Gray with Access Door
96484BNS	Brown with Access Door
96484GNS	Green with Access Door
96484GYS	Gray with Access Door
96484SBS	Slate Blue with Access Door
96484SDS	Sand with Access Door

Ideal For Use In: Correctional Facilities, Behavioral/Mental Health Facilities & Law Enforcement/Security.

Our Intense Use and Correctional Specific products contribute to a safe and humane environment. For Full Specifications Call Toll Free 800-571-0770 / Fax: 630-455-0813 / or Visit www.cortechusa.com

OVERVIEW

The Sabre Chair has an EXTREME load capacity. Can be used as stand alone or be ganged together. Can be bolted together, in place, as well as to the floor via concealed pilot holes. Can be easily filled with sand through ballast door on site to weigh down. Secures with tamperproof screws. **Manufactured to ISO Quality Standards in the USA.**

FABRICATION/MATERIAL

Durable, one piece, rotationally molded design for increased strength. Constructed with high impact "no break" polyethylene. Flame Retardant (as shown passes Cal 133). Test reports available upon request.

COLOR See chart, custom colors available upon request.

WEIGHT 38 lbs.

OPTIONS Can be bolted to the floor via concealed pilot holes and can be filled with sand through ballast door on site to weigh down.

ASSEMBLY N/A

WARRANTY 10 Year Warranty.

MAINTENANCE Easy to clean and maintain with damp cloth. Resistant to stains.

STATIC LOAD +1000 lbs.

TEST RESULTS

- Passes ANSI/BIFMA X5.1-2011
- Passed product dynamic drop tested to a relative impact force of 500 lbs. from 18"

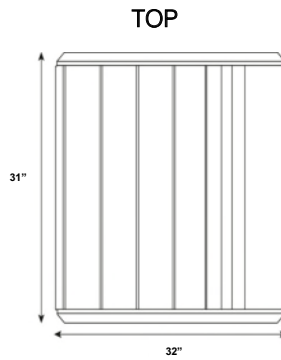
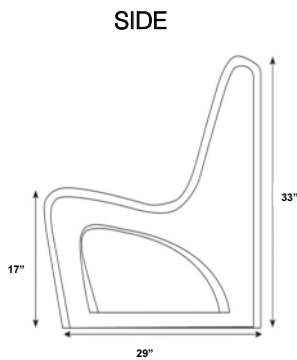
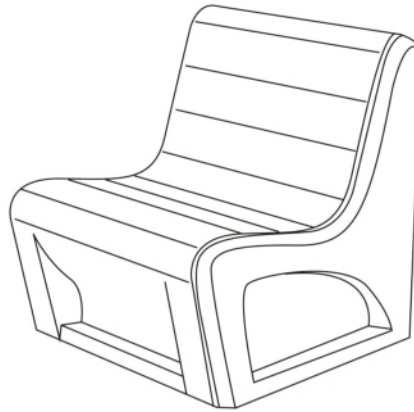

BACK w/ACCESS DOOR

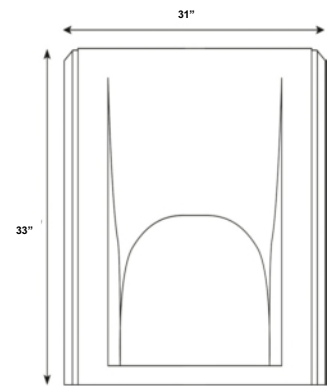

The Sentinel Arm Chair

It has an EXTREME load capacity and designed to stand alone or be ganged together. The ergonomic design provides maximum comfort using rotational molding technology.

**10 Year
Warranty**



33H x 24W x 24D

FEATURES:

- Durable, one piece, rotationally molded design for increased strength. Constructed of high impact “no break” polyethylene. No steel or wood components.
- Can be used alone or be ganged together.
- Can be bolted together, in place, as well as to the floor via concealed pilot holes.
- Can be easily filled with sand through optional ballast door on site to weigh down. Secures with tamperproof screws.
- 1500 lb. static load.
- Resistant to stains. Easy to clean & maintain.
- Flame Retardant (passes Cal 133). Test reports available upon request.
- Manufactured to ISO Quality Standards in the USA.



- 24” W x 24” D x 33” H
- Durable, one piece, rotationally molded polyethylene lounge chair
- Can be bolted to the floor with concealed mounting holes or ganged together for groupings
- Optional tamperproof backside sand bag ballast port for easy safety weighting
- Flame Retardant (passes Cal 133), 1,500 pound static load tested
- Virtually unbreakable / 10 year warranty / Stain resistant
- Owner specified color from 7 standard options

ITEM	DESCRIPTION
106484BK	Black
106484BG	Blue Gray
106484BN	Brown
106484GN	Green
106484GY	Gray
106484SB	Slate Blue
106484SD	Sand

ITEM	DESCRIPTION
106484BKS	Black with Access Door
106484BGS	Blue Gray with Access Door
106484BNS	Brown with Access Door
106484GNS	Green with Access Door
106484GYS	Gray with Access Door
106484SBS	Slate Blue with Access Door
106484SDS	Sand with Access Door



Custom colors available upon request. Call Cortech for details.

Ideal For Use In: Correctional Facilities, Behavioral/Mental Health Facilities & Law Enforcement/Security.

Our Intense Use and Correctional Specific products contribute to a safe and humane environment. For Full Specifications Call Toll Free 800-571-0770 / Fax: 630-455-0813 / or Visit www.cortechusa.com

OVERVIEW

The Sentinel Arm Chair has an EXTREME load capacity. Can be used as stand alone or be ganged together. Can be bolted together, in place, as well as to the floor via concealed pilot holes. Can be easily filled with sand through ballast door on site to weigh down. Secures with tamperproof screws. **Manufactured to ISO Quality Standards in the USA.**

FABRICATION/MATERIAL

Durable, one piece, rotationally molded design for increased strength. Constructed with high impact "no break" polyethylene. No steel or wood components Flame Retardant (as shown passes Cal 133). Test reports available upon request.

COLOR See Chart Below, custom colors available upon request.

WEIGHT 30 lbs.

OPTIONS Can be bolted to the floor via concealed pilot holes and can be filled with sand through ballast door on site to weigh down.

ASSEMBLY N/A

WARRANTY 10 Year Warranty.

MAINTENANCE Easy to clean and maintain with damp cloth.
Resistant to stains.

STATIC LOAD +750 lbs.

TEST RESULTS Passes ANSI/BIFMA X5.1-2011.

Passed product dynamic drop tested to a relative force of 500 lbs. from 18"

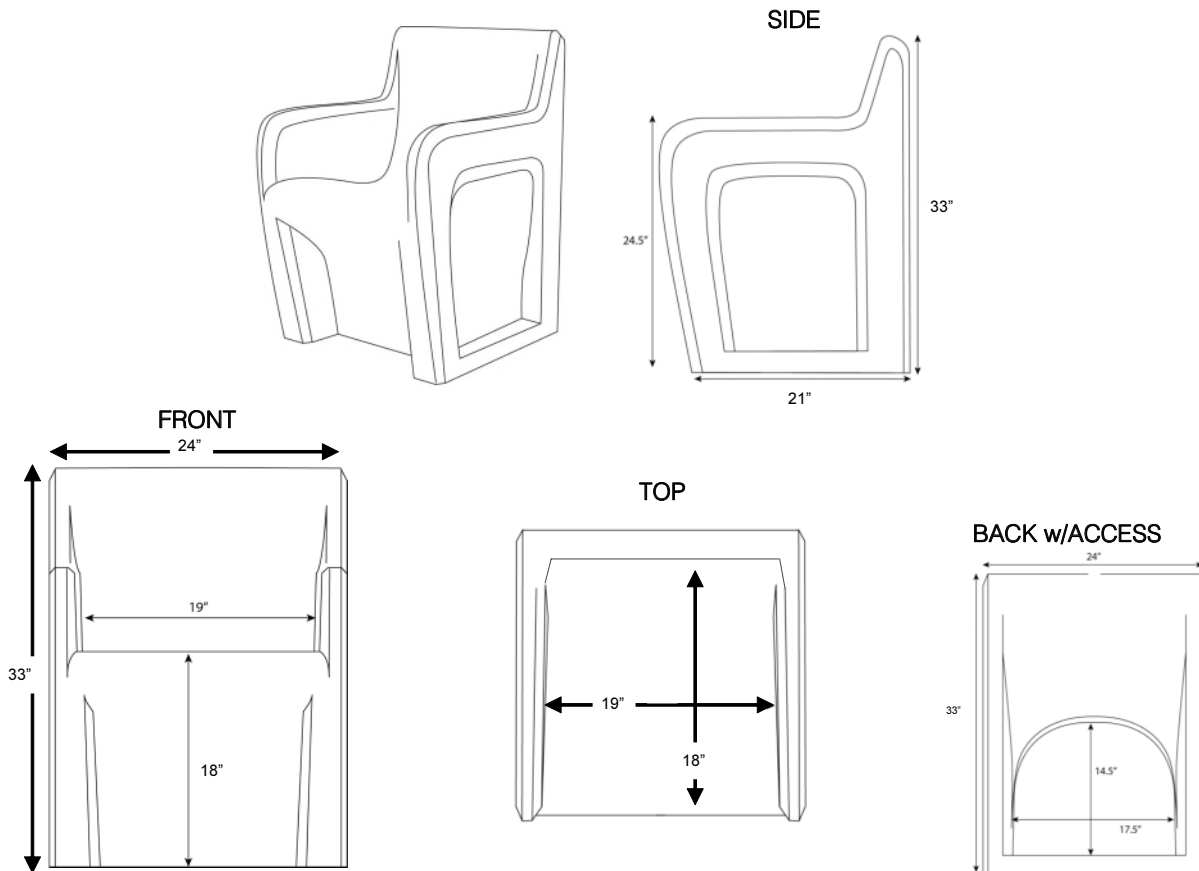

The Sentinel Armless Chair

It has an EXTREME load capacity and designed to stand alone or be ganged together. The ergonomic design provides maximum comfort using rotational molding technology.

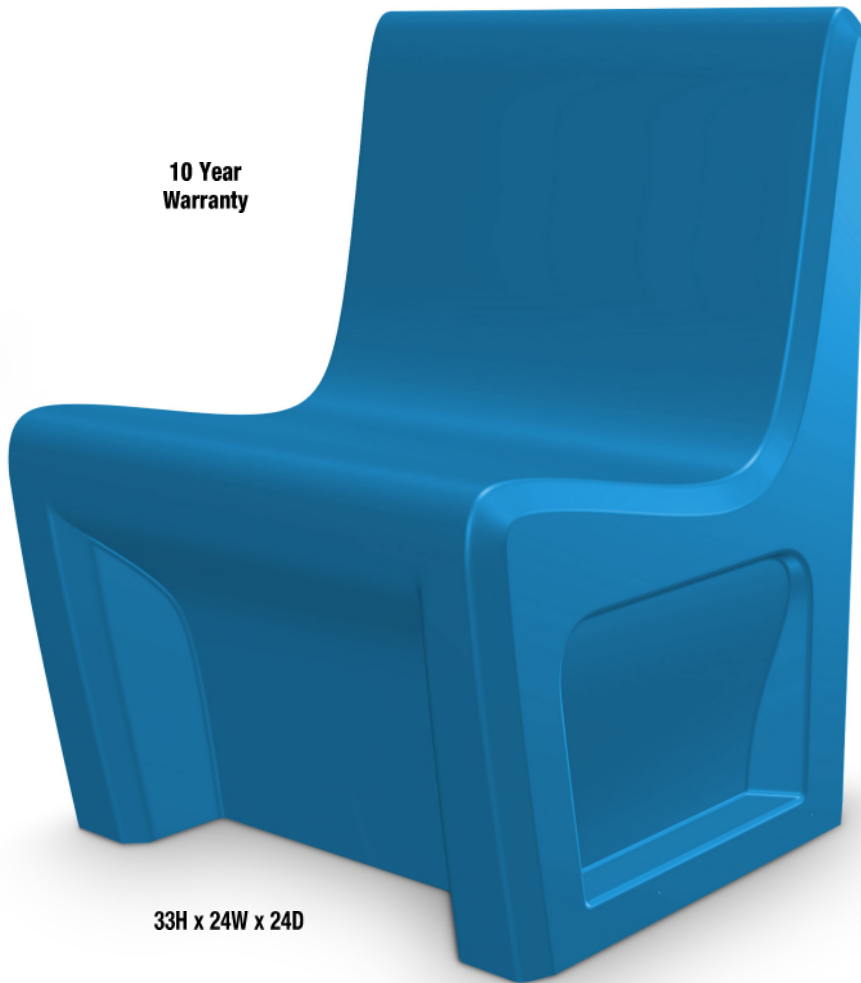

**10 Year
Warranty**

33H x 24W x 24D

FEATURES:

- Durable, one piece, rotationally molded design for increased strength. Constructed of high impact “no break” polyethylene. No steel or wood components.
- Can be bolted together, in place, as well as to the floor via concealed pilot holes.
- Can be used alone or be ganged together.
- Can be easily filled with sand through optional ballast door on site to weigh down. Secures with tamperproof screws.
- 1500 lb. static load.
- Resistant to stains. Easy to clean & maintain.
- Flame Retardant (passes Cal 133). Test reports available upon request.
- Manufactured to ISO Quality Standards in the USA. 

- 24” W x 24” D x 33” H
- Durable, one piece, rotationally molded polyethylene lounge chair
- Can be bolted to the floor with concealed mounting holes or ganged together for groupings
- Optional tamperproof backside sand bag ballast port for easy safety weighting
- Flame Retardant (passes Cal 133)
- Virtually unbreakable / 10 year warranty / Stain resistant
- Owner specified color from 7 standard options

ITEM	DESCRIPTION
116484BK	Black
116484BG	Blue Gray
116484BN	Brown
116484GN	Green
116484GY	Gray
116484SB	Slate Blue
116484SD	Sand

ITEM	DESCRIPTION
116484BKS	Black with Access Door
116484BGS	Blue Gray with Access Door
116484BNS	Brown with Access Door
116484GNS	Green with Access Door
116484GYS	Gray with Access Door
116484SBS	Slate Blue with Access Door
116484SDS	Sand with Access Door



Custom colors available upon request. Call Cortech for details.

Ideal For Use In: Correctional Facilities, Behavioral/Mental Health Facilities & Law Enforcement/Security.

Our Intense Use and Correctional Specific products contribute to a safe and humane environment. For Full Specifications Call Toll Free 800-571-0770 / Fax: 630-455-0813 / or Visit www.cortechusa.com

OVERVIEW

The Sentinel Armless Chair has an EXTREME load capacity. Can be used as stand alone or be ganged together. Can be bolted together, in place, as well as to the floor via concealed pilot holes. Can be easily filled with sand through ballast door on site to weigh down. Secures with tamperproof screws. **Manufactured to ISO Quality Standards in the USA.**

FABRICATION/MATERIAL

Durable, one piece, rotationally molded design for increased strength. Constructed with high impact "no break" polyethylene. No steel or wood components Flame Retardant (as shown passes Cal 133). Test reports available upon request.

COLOR See Chart Below, custom colors available upon request.

WEIGHT 30 lbs.

OPTIONS Can be bolted to the floor via concealed pilot holes and can be filled with sand through ballast door on site to weigh down.

ASSEMBLY N/A

WARRANTY 10 Year Warranty.

MAINTENANCE Easy to clean and maintain with damp cloth. Resistant to stains.

STATIC LOAD +750 lbs.

TEST RESULTS Passes ANSI/BIFMA X5.1-2011

Passed product dynamic drop tested to a relative force of 500 lbs. from 18"

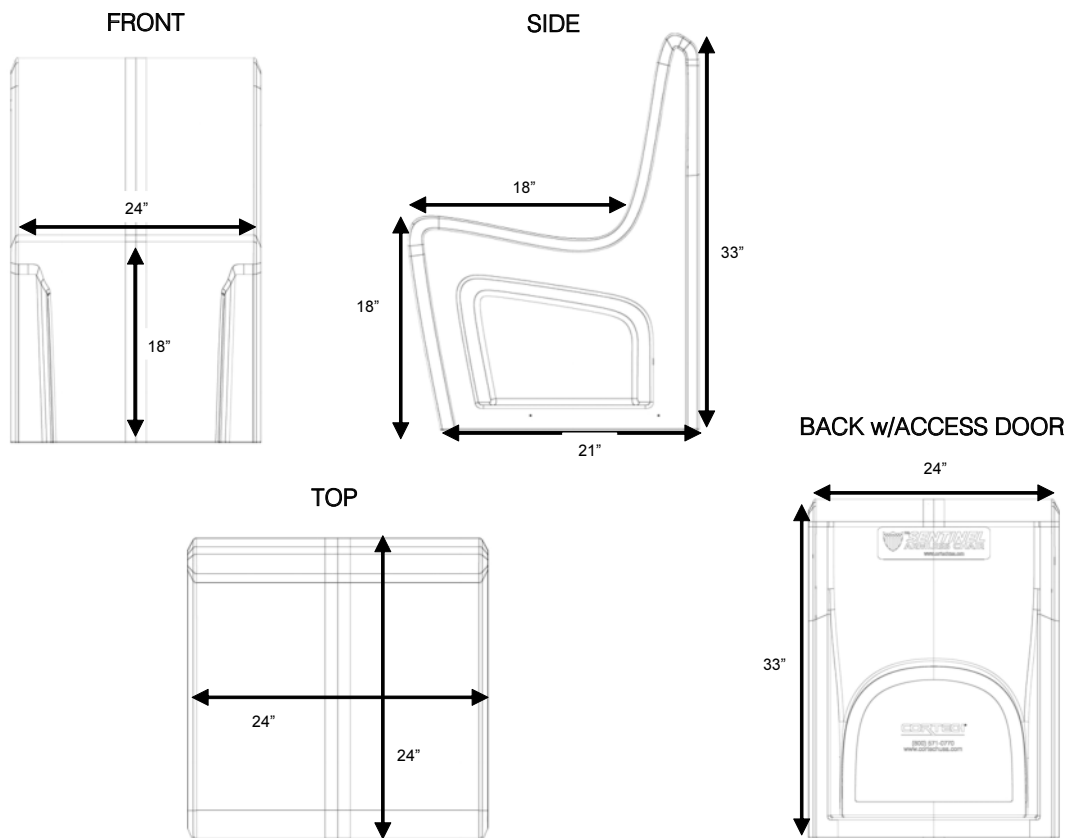

The RazorBack Chair

The RazorBack chair's "Muscle-Back" leg design and "Structural Span" provide MAXIMUM STRENGTH. In addition, it has an EXTREME load capacity and the ergonomic low back design is more resistant to chair leaning or rocking – which can cause stress and failure in other chairs used in similar use environments.



**10 Year
Warranty**

- Size: 30" H x 21" W x 21" D
- One piece anti-ligature injection molded polypropylene chair with 56 structural ribs under seat
- 10 Year Warranty / Stain resistant / Virtually unbreakable
- Muscle-back legs include bolt down option / No steel or wood components
- 1500 lb. static load capacity / Cal 133 Flame retardant / Passes ASTM F1561-03
- Owner specified color from 7 standard color options.

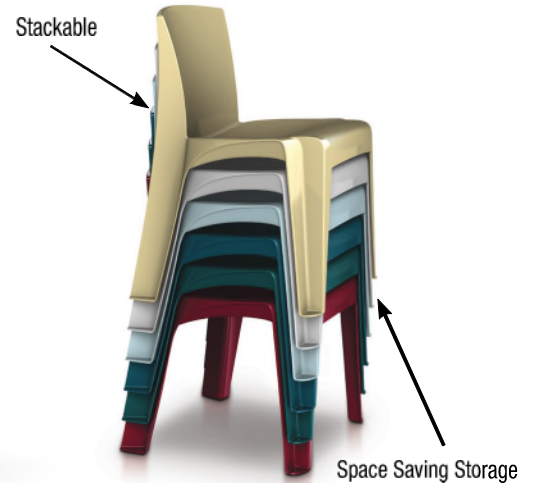

FEATURES:

- Durable, one piece, injection molded design for increased strength. Constructed with high impact "no break" polypropylene. No steel or wood components
- Muscle-Back Legs include bolt down option
- Flame retardant (passes Cal 133).
Test reports available upon request
- 1500 lb. static load
- Passes ASTM F1561-03
- Manufactured to ISO Quality Standards in the USA



ITEM	DESCRIPTION
86484BK	Black
86484B	Buff
86484FG	Fog Gray
86484T	Teal
86484SB	Slate Blue
86484P	Plum
86484BG	Blue Gray
86484GN	Green
86484BN	Brown
DY9000	Chair Dolly



Custom colors available upon request. Call Cortech for details.

Ideal For Use In: Correctional Facilities, Behavioral/Mental Health Facilities & Law Enforcement/Security.

Our Intense Use and Correctional Specific products contribute to a safe and humane environment.
For Full Specifications Call Toll Free 800-571-0770 / Fax: 630-455-0813 / or Visit www.cortechusa.com

OVERVIEW

The RazorBack Chair has an EXTREME load capacity. The RazorBack chair's "Muscle-Back" leg design and "Structural Span" provide MAXIMUM STRENGTH. In addition, the ergonomic low back design is more resistant to chair leaning or rocking – which can cause stress and failure in other chairs used in similar use environments. **Manufactured to ISO Quality Standards in the USA.**

FABRICATION/MATERIAL

Durable, one piece, injection molded design for increased strength. Constructed with high impact "no break" polypropylene. No steel or wood components Flame Retardant (as shown passes Cal 133). Test reports available upon request.

COLOR See chart, custom colors available upon request.

WEIGHT 8.25 lbs.

OPTIONS N/A

ASSEMBLY N/A

WARRANTY 10 Year Warranty.

MAINTENANCE Easy to clean and maintain with damp cloth.
Resistant to stains.

STATIC LOAD 1500 lbs. / - Passes ANSI/BIFMA X5.1-2011

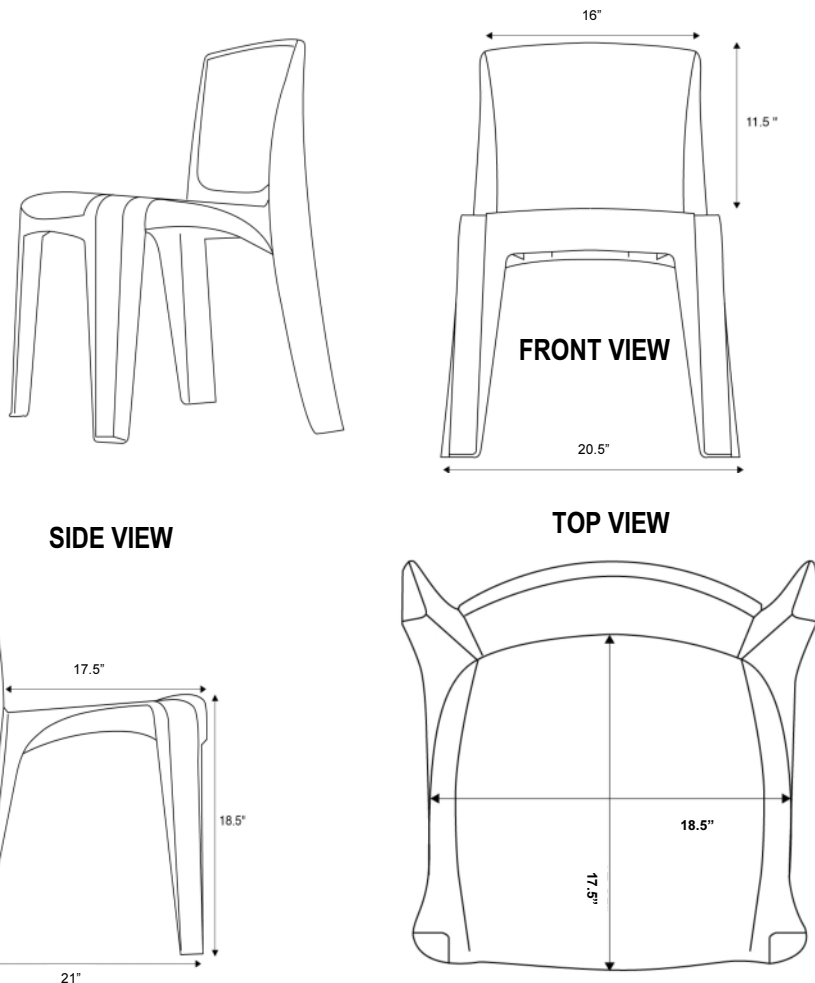

The Endurance Bed 0.0

Correctional Bed - Small

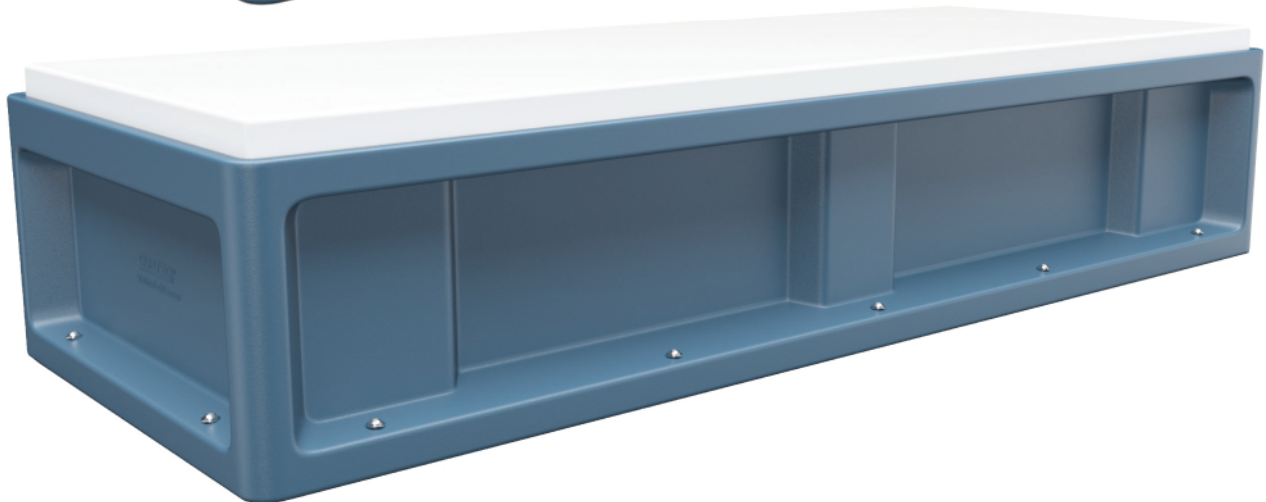
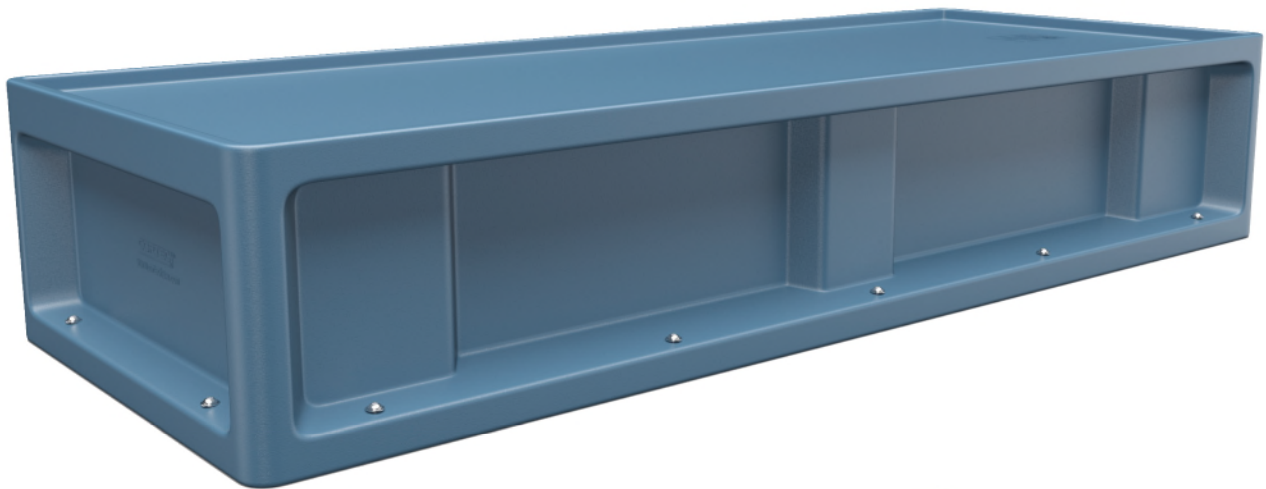

ITEM	DESCRIPTION
7500BK	Black FR
7500BG	Blue Gray FR
7500BN	Brown FR
7500GN	Green FR
7500GY	Gray FR
7500SB	Slate Blue FR
7500SD	Sand FR

FEATURES:

- Designed for use with **30" x 77"** mattress.
- Molded in side and end for increased structural span strength.
- Flame Retardant (passes Cal 133). Test reports available upon request.
- Easy to clean and maintain.
- Stain resistant.
- 10 Year Warranty.
- Durable, one piece, rotationally molded design for increased strength. Constructed of high impact "no break" polyethylene.
- Can be bolted to the floor via concealed pilot holes with hardware of your choice.
- Manufactured to ISO Quality Standards in the USA. 

Available in



Custom colors available upon request. Call Cortech for details.

Ideal For Use In: Correctional Facilities, Behavioral/Mental Health Facilities & Law Enforcement/Security.

Our Intense Use and Correctional Specific products contribute to a safe and humane environment. For Full Specifications Call Toll Free 800-571-0770 / Fax: 630-455-0813 / or Visit www.cortechusa.com 62

OVERVIEW

The Endurance Bed 0.0 is a versatile, heavy duty sleep surface and is ideal for continuous, intensive use in correctional or institutional environments.

Manufactured to ISO Quality Standards in the USA.

FABRICATION/MATERIAL

Durable, one piece, rotationally molded design for increased strength. Constructed of high impact polyethylene. No steel or wood components. Flame Retardant (as shown passes Cal 133). Test reports available upon request.

COLOR See Chart, custom colors available upon request.

WEIGHT 80 lbs.

OPTIONS N/A

ASSEMBLY Bolt to the floor via concealed pilot holes with hardware of your choice.

WARRANTY 10 Year Warranty.

MAINTENANCE Easy to clean and maintain with damp cloth. Resistant to stains.

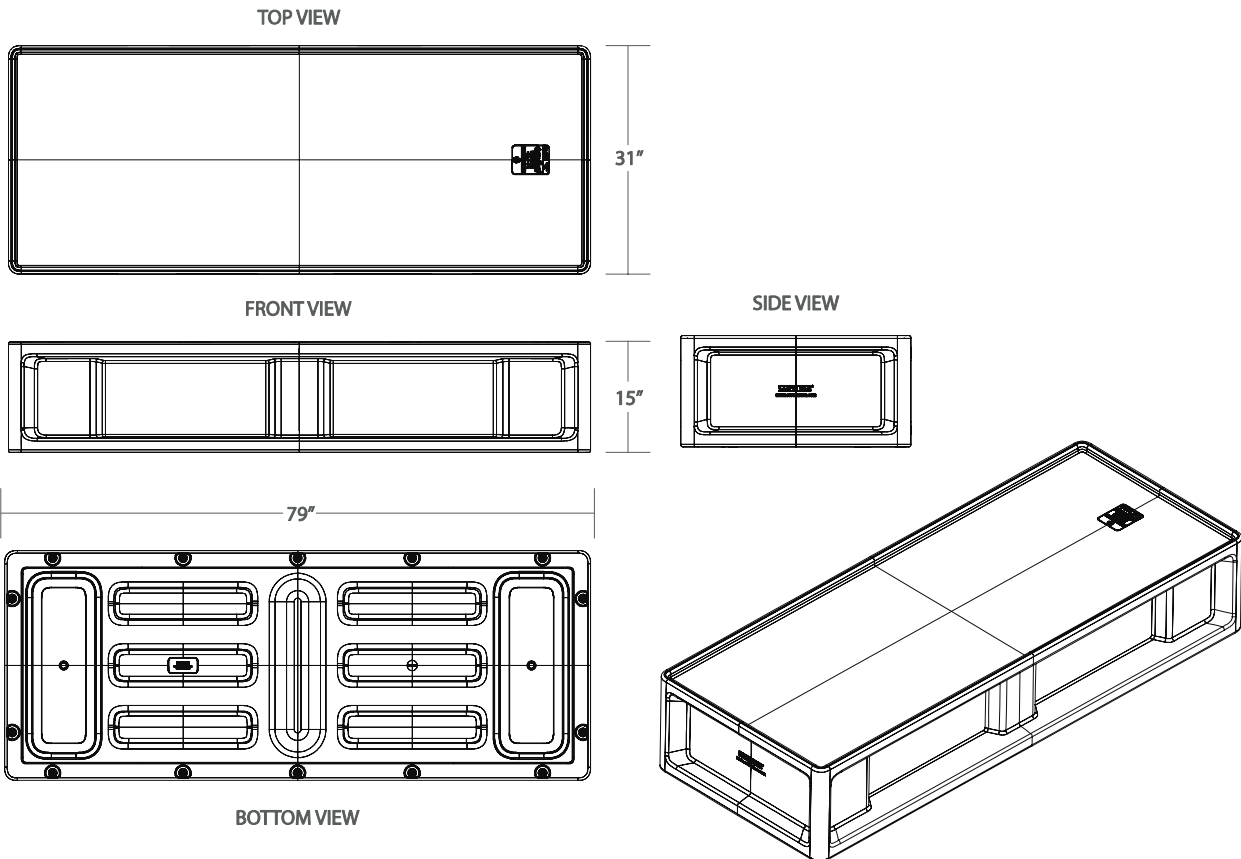

The Endurance Bed 1.0

10 Year Warranty

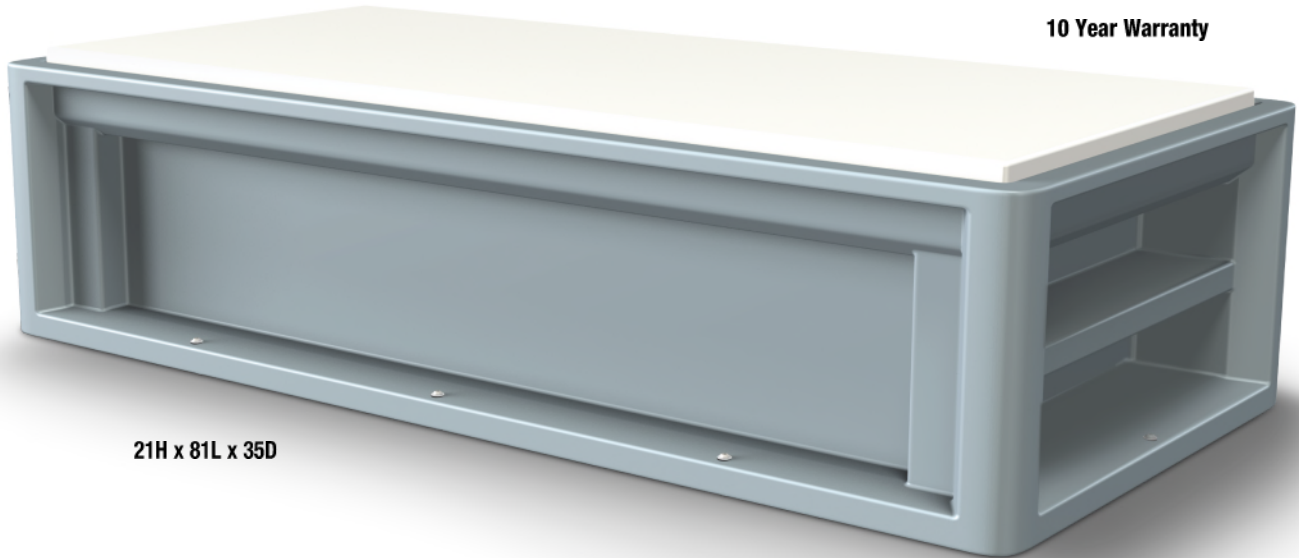

21H x 81L x 35D

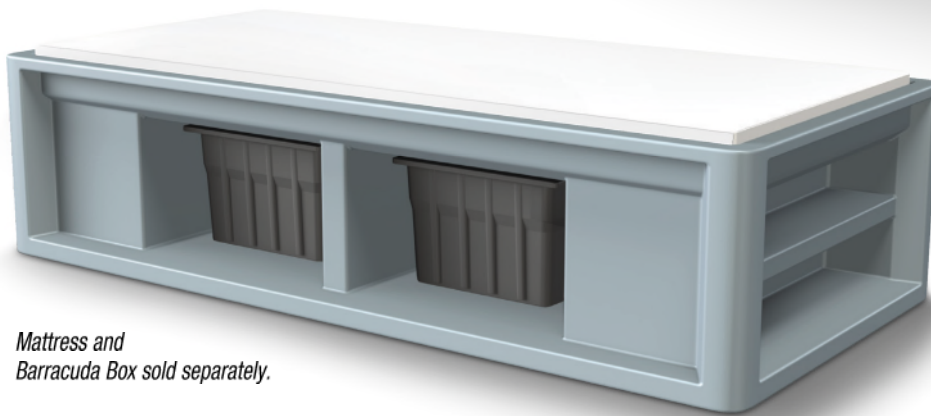

Mattress and Barracuda Box sold separately.

- Size: 35" D x 81" L x 21" H
- Bed Deck - 30" x 75"
- One piece rotationally molded polyethylene material / No steel or wood components
- Can be bolted to the floor with concealed mounting holes / Under bed and end storage is standard
- Flame Retardant (passes Cal 133) / No foam
- Virtually unbreakable / 10 year warranty / Stain resistant
- Owner specified color from 7 standard options

FEATURES:

- Designed for use with **30" x 75"** mattress.
- Molded in side slots for property box storage and increased structural span strength. Bed can be reverse-mounted to eliminate property box storage feature.
- Molded in end shelving for open storage of personal items.
- Flame Retardant (passes Cal 133). Test reports available upon request.
- Durable, one piece, rotationally molded design for increased strength. Constructed of high impact "no break" polyethylene.
- Stain resistant.
- Easy to clean and maintain.
- Can be bolted to the floor via concealed pilot holes with hardware of your choice.
- Manufactured to ISO Quality Standards in the USA.



ITEM	DESCRIPTION
7601BK	Black FR
7601BG	Blue Gray FR
7601BN	Brown FR
7601GN	Green FR
7601GY	Gray FR
7601SB	Slate Blue FR
7601SD	Sand FR



Custom colors available upon request. Call Cortech for details.

Ideal For Use In: Correctional Facilities, Behavioral/Mental Health Facilities & Law Enforcement/Security.

OVERVIEW

The Endurance Bed is a versatile, heavy duty sleep surface and is ideal for continuous, intensive use in correctional or institutional environments. Molded in side slots for property box storage and increased structural span strength. Molded in end shelving for open storage of personal items. **Manufactured to ISO Quality Standards in the USA.**

Designed for use with 30" x 75" mattress.

FABRICATION/MATERIAL

Durable, one piece, rotationally molded design for increased strength. Constructed of high impact polyethylene. No steel or wood components. Flame Retardant (as shown passes Cal 133). Test reports available upon request.

COLOR See Chart, custom colors available upon request.

WEIGHT 110 lbs.

OPTIONS N/A

ASSEMBLY Bolt to the floor via concealed pilot holes with hardware of your choice.

WARRANTY 10 Year Warranty.

MAINTENANCE Easy to clean and maintain with damp cloth. Resistant to stains.

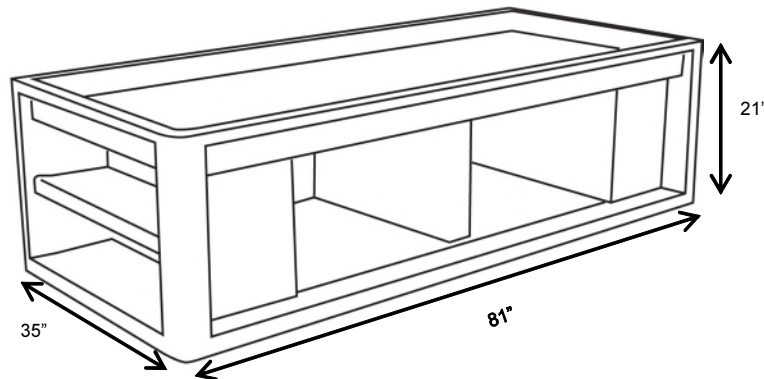

STORAGE SIDE

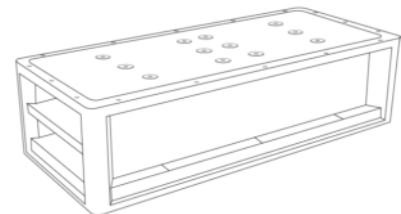
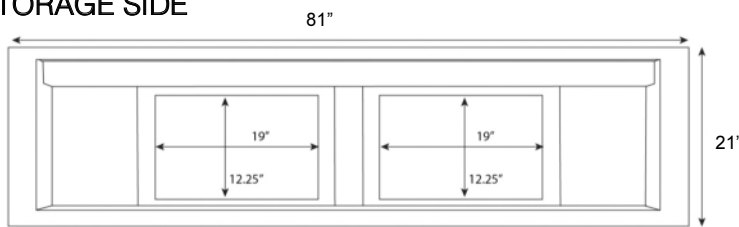

CLOSED SIDE

TOP SIDE

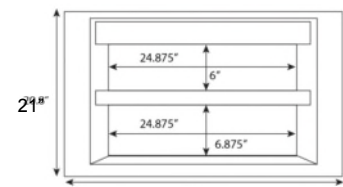
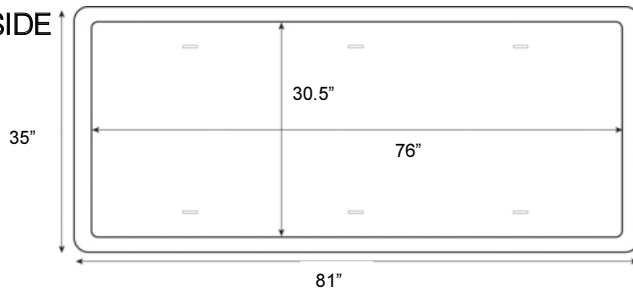

END

The Endurance Bed 2.0

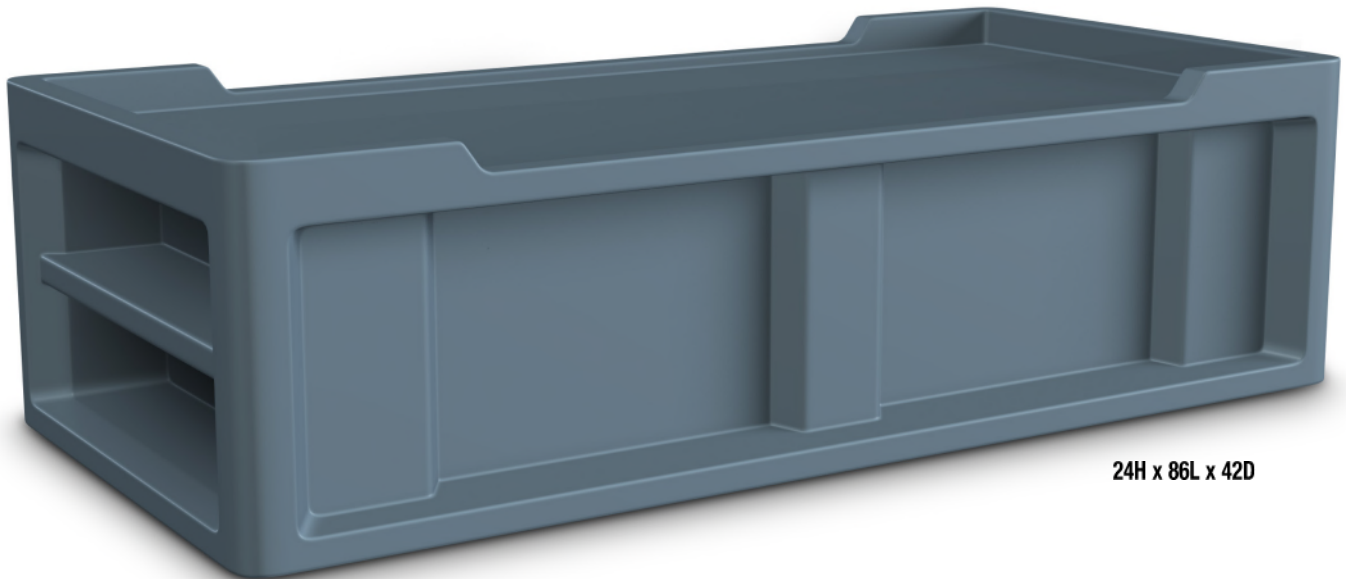

24H x 86L x 42D

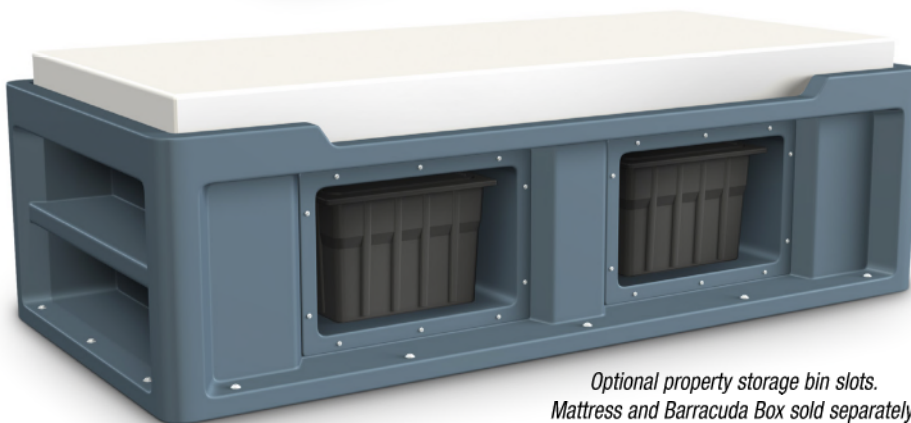

Optional property storage bin slots.
Mattress and Barracuda Box sold separately.

FEATURES:

- Designed for use with **36" x 80"** mattress.
- Angled lowered side rail for easier entry and exit.
- Molded in end shelving for open storage of personal items.
- Easy to clean and maintain.
- Stain resistant.
- Durable, one piece, rotationally molded design for increased strength. Constructed of high impact "no break" polyethylene.
- Can be bolted to the floor via concealed pilot holes with hardware of your choice.
- Field installed restraint rings available.
- Optional side slots for property box storage.
- Flame Retardant (passes Cal 133). Test reports available upon request.
- Manufactured to ISO Quality Standards in the USA.

- Size: 42"D x 86"W x 24"H - Bed Deck 36" x 80"
- One piece rotationally anti-ligature molded polyethylene bed
- Can be bolted to the floor with concealed mounting holes
- Flame Retardant (passes Cal 133) / No foam
- Virtually unbreakable / 10 year warranty / Stain resistant
- Owner specified color from 7 standard options

ITEM	DESCRIPTION
7801BK	Black FR
7801BG	Blue Gray FR
7801BN	Brown FR
7801GN	Green FR
7801GY	Gray FR
7801SB	Slate Blue FR
7801SD	Sand FR



Custom colors available upon request. Call Cortech for details.

Ideal For Use In: Correctional Facilities, Behavioral/Mental Health Facilities & Law Enforcement/Security.

Our Intense Use and Correctional Specific products contribute to a safe and humane environment.
For Full Specifications Call Toll Free 800-571-0770 / Fax: 630-455-0813 / or Visit www.cortechusa.com

OVERVIEW

The Endurance Bed 2.0 is a versatile, heavy duty sleep surface and is ideal for continuous, intensive use in correctional or institutional environments. Optional molded in side slots for property box storage and increased structural span strength. Angled lowered side rail for easier entry and exit. Molded in end shelving for open storage of personal items. **Manufactured to ISO Quality Standards in the USA.**

Designed for use with 36" x 80" mattress.

FABRICATION/MATERIAL

Durable, one piece, rotationally molded design for increased strength. Constructed of high impact polyethylene. No steel or wood components. Flame Retardant (as shown passes Cal 133). Test reports available upon request.

COLOR See Chart, custom colors available upon request.

WEIGHT 145 lbs.

OPTIONS N/A

ASSEMBLY Bolt to the floor via concealed pilot holes with hardware of your choice.

WARRANTY 10 Year Warranty.

MAINTENANCE Easy to clean and maintain with damp cloth. Resistant to stains.

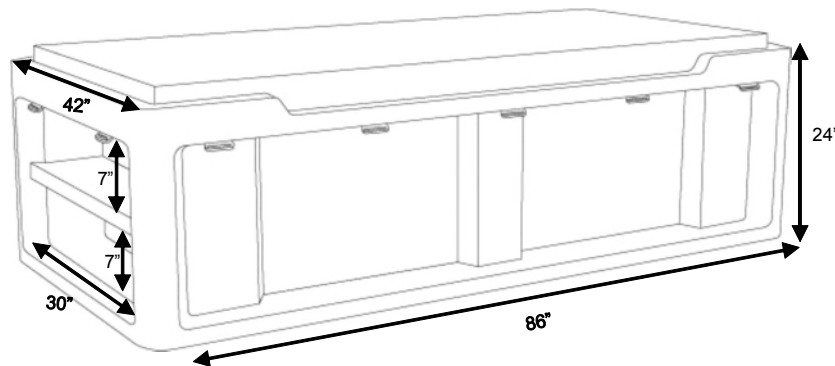

TOP

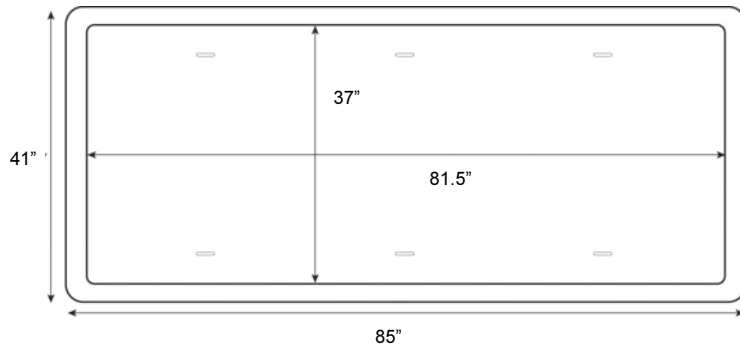

OPTIONAL PROPERTY BOX SIDE

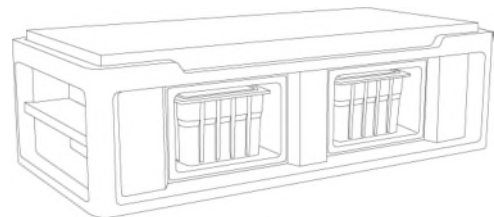

The Barracuda Box

The Toughest Inmate Property Storage Box, is specifically designed to exceed all requirements of an inmate property storage box. The Barracuda Box is stronger, lighter and more functional than other inmate property storage boxes.



10 Year Warranty

- 1.5cu. ft. 17.5"D x 23"W x 8.5"H
- 2.0cu ft. 17.5"D x 23"W x 11.5"H
- 3.0cu ft. 18"D x 28.25"W x 12.5"H
- 1.5 & 2.0cu. ft. Lid
17.5"D x 23.5"W x 1.5" H /
3.0cu ft. Lid 18.5"D x 29"W x 1.5"H
- Each Barracuda Box is individually numbered for effective inmate ID and property control.
- "Stack and Nest" Design- Stack property boxes with or without a lid without crushing its contents.
- Constructed with high impact "no break" polypropylene.
- Flame Retardant (passes CAL 133)
- Virtually unbreakable / 10 year warranty / Stain resistant

FEATURES:

- "Stack and Nest" Design - Stack property boxes with or without a lid without crushing the contents of the Barracuda Box. "Nest" property boxes inside one another by simply turning the empty box 180 degrees. Save on freight and save storage space.
- Each Barracuda Box is individually numbered for effective inmate ID and property control.
- Box capacity 1.5 (Regular), 2.0 cu. ft. (Large) and 3.0 cu. ft. (X-Large).
- Locking hasp on both sides of the box.
- Radius design (rounded edges and corners) for maximum impact dispersion and resistance.
- Vertical radiused structural columns for maximum strength and impact resistance.
- Constructed with high impact "no break" polypropylene.
- Flame Retardant (Passes CAL133). Test results available upon request.
- Manufactured to ISO Quality Standards in the USA. 

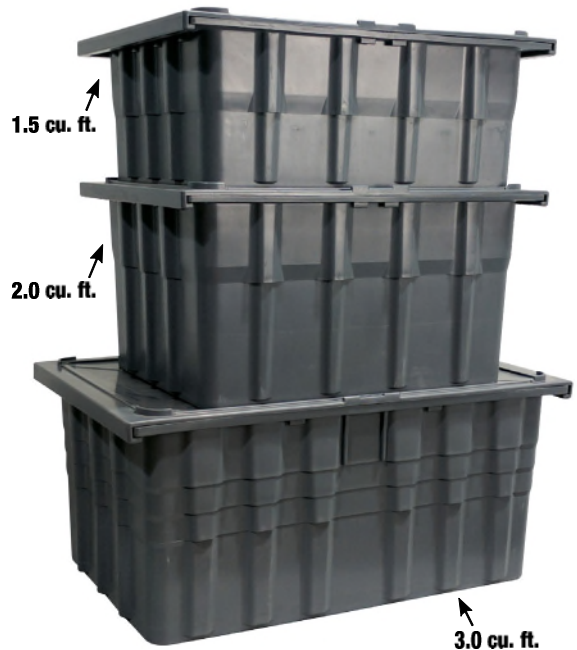

ITEM	DESCRIPTION	HEIGHT x WIDTH x DEPTH
3825P	Barracuda Box, Standard 1.5 cu. ft.	8.5" x 23" x 17.5"
7268P	Barracuda Box, Large 2.0 cu. ft.	11.5" x 23" x 17.5"
8568P	Barracuda Box, 3.0 cu. ft.	12.5" x 28.25" x 18"
9689P	Barracuda Box Lid, 1.5 & 2.0 cu. ft. Boxes	17.5" x 23.5" x 1.5"
8289P	Barracuda Box Lid, 3.0 cu. ft. Box	18.5" x 29" x 1.5"

Ideal For Use In: Correctional Facilities, Behavioral/Mental Health Facilities & Law Enforcement/Security.

Our Intense Use and Correctional Specific products contribute to a safe and humane environment. For Full Specifications Call Toll Free 800-571-0770 / Fax: 630-455-0813 / or Visit www.cortechusa.com

OVERVIEW

The Barracuda Box, The Toughest Inmate Property Storage Box, is specifically designed to exceed all requirements of an inmate property storage box. The Barracuda Box is stronger, lighter and more functional than other inmate property storage boxes. **Manufactured to ISO Quality Standards in the USA.**

FABRICATION/MATERIAL

Constructed of high impact, no break, polypropylene. Flame Retardant (Passes CAL133). Test results available upon request.

“Stack and Nest” Design - Stack property boxes with or without a lid without crushing the contents of the Barracuda Box. “Nest” property boxes inside one another by simply turning the empty box 180 degrees. Save on freight and save storage space. Each Barracuda Box is individually numbered for effective inmate ID and property control. Radius design (rounded edges and corners) for maximum impact dispersion and resistance. Vertical radiused structural columns for maximum strength and impact resistance. Locking hasp on both sides of the box.

COLOR Gray. Custom colors available upon request

OPTIONS N/A

ASSEMBLY N/A

WARRANTY 10 Year Warranty.

MAINTENANCE Easy to clean and maintain with damp cloth. Resistant to stains.

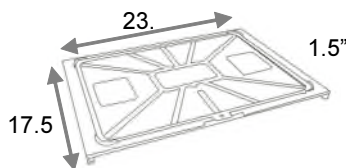
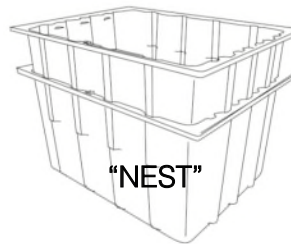

LID for 1.5 & 2.0 cu.

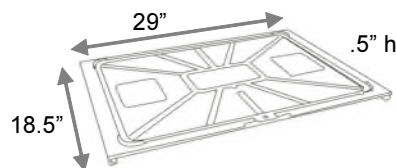

LID for 3.0 cu. ft.

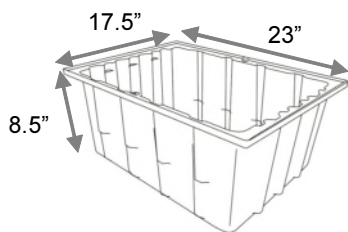

1.5 cu. ft. box

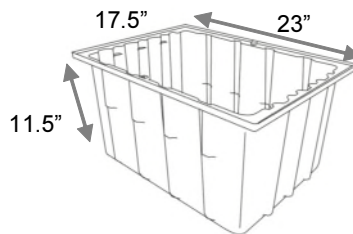

2.0 cu. ft. box

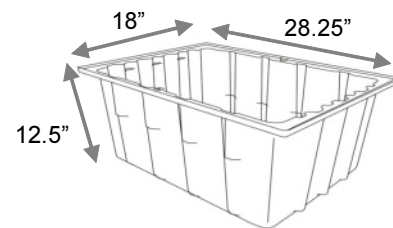

3.0 cu. ft. box

The ultimate in security and safety for inmate property. The Cortech Master Box, The Toughest Locking Inmate Property Storage Box, is specifically designed to exceed all requirements of an inmate property storage box and system. The Master Box is stronger, lighter and more functional than other inmate property storage boxes. It is built with an integral combination dial lock and staff override key.



Patent Pending

- 1.5cu. ft. 17.5"D x 23"W x 8.5"H
- 2.0cu ft. 17.5"D x 23"W x 11.5"H
- 3.0cu ft. 18"D x 28.25"W x 12.5"H
- 1.5 & 2.0cu. ft. Lid 17.5"D x 23.5"W x 1.5" / 3.0cu ft. Lid 18.5"D x 29"W x 1.5"H
- Integral tamper resistant combination dial comes with a master override key / Eliminates the need for dangerous padlocks.
- "Stack and Nest" Design- Stack property boxes with or without a lid without crushing its contents.
- Constructed with high impact "no break" polypropylene.
- Flame Retardant (passes CAL 133).
- Integral combination lock and hasp safely secures the sliding lid to the box.
- Virtually unbreakable / Stain resistant

FEATURES:

- Integral tamper resistant combination dial lock comes with a master override key.
- Eliminates the need for dangerous padlocks.
- "Stack and Nest" Design - Stack property boxes with or without a lid without crushing the contents of the Master Box.
- Box capacity 1.5 cu. ft. (Standard)*
- Box capacity 2.0 cu. ft. (Large)*
- Box capacity 3.0 cu. ft. (X-Large)*
- Radius design (rounded edges and corners) for maximum impact dispersion and resistance.
- Vertical radiused structural columns for maximum strength and impact resistance.
- Constructed with high impact "no break" polypropylene.
- Flame Retardant (Passes CAL133). Test results available upon request.
- Integral combination lock and hasp safely secures the sliding lid to the box.
- Custom colors available
- 1 year warranty
- Manufactured to ISO Quality Standards in the USA

*Call Cortech for exact dimensions and test data.

ITEM	DESCRIPTION	HEIGHT x WIDTH x DEPTH
3825M	Master Box, Standard	8.5" x 23" x 17.5"
7268M	Master Box, Large	11.5" x 23" x 17.5"
8568M	Master Box, 3.0 cu. ft.	12.5" x 28.25" x 18"
9689M	Master Box Lid, 1.5 & 2.0 cu. ft. Boxes	17.5" x 23.5" x 1.5"
8289M	Master Box Lid, 3.0 cu. ft. Box	18.5" x 29" x 1.5"



Ideal For Use In: Correctional Facilities, Behavioral/Mental Health Facilities & Law Enforcement/Security.

Our Intense Use and Correctional Specific products contribute to a safe and humane environment. For Full Specifications Call Toll Free 800-571-0770 / Fax: 630-455-0813 / or Visit www.cortechusa.com

OVERVIEW

The MasterBox is The Toughest Lockable Inmate Property Storage Box and is specifically designed to exceed all requirements of an inmate property storage box. The MasterBox is stronger, lighter and more functional than other inmate property storage boxes. **It is built with an integral combination dial lock and staff override key. Manufactured to ISO Quality Standards in the USA.**

FABRICATION/MATERIAL

Constructed of high impact, no break, polypropylene. Flame Retardant (Passes CAL133). Test results available upon request.

Integral tamper resistant combination dial lock comes with a master override key which eliminates the need for dangerous padlocks. "Stack and Nest" Design - Stack property boxes with or without a lid without crushing the contents of the MasterBox. "Nest" property boxes inside one another by simply turning the empty box 180 degrees. Save on freight and save storage space. Radius design (rounded edges and corners) for maximum impact dispersion and resistance. Vertical radiused structural columns for maximum strength and impact resistance. Locking hasp on both sides of the box.

COLOR Gray. Custom colors available upon request

WEIGHT(s): See chart

OPTIONS N/A

ASSEMBLY N/A

WARRANTY 1 Year Warranty.

MAINTENANCE Easy to clean and maintain with damp cloth.
Resistant to stains.

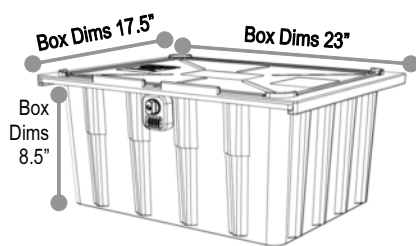

Standard 1.5 cu. ft.

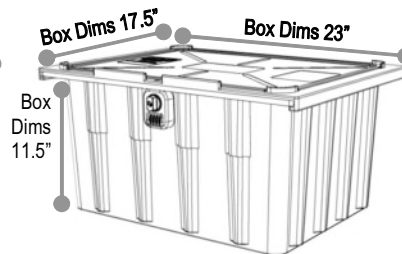

Large 2.0 cu. ft.

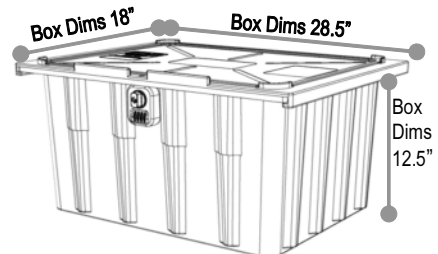

Extra Large 3.0 cu. ft.

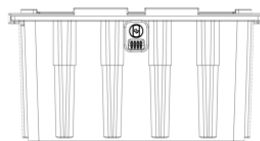

FRONT VIEW

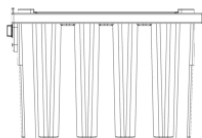

SIDE VIEW

LID for 1.5 & 2.0 cu. ft.

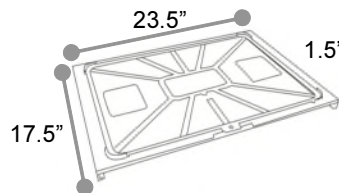

LID for 3.0 cu. ft.

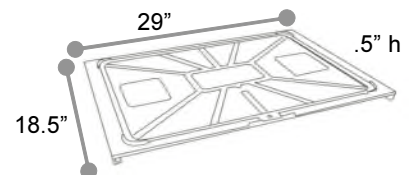

STATE OF MICHIGAN

Contract No. 200000000373
Statewide – Anti-Ligature Furnishing Services

SCHEDULE F
Derby SEG-MAX Pinnacle Mattress

Please Refer to Pages 72 – 76



24350 State Road 23 South, South Bend IN 46614
Toll Free: (866)233-4500 Fax: (574)288-4550
Mattresses: www.derbyindustries.com
Email: sales @derbyindustries.com

Product Specifications for the Derby SEG-MAX Pinnacle Mattress

The Derby SEG-MAX Pinnacle Mattress is produced by special manufacturing techniques. The 100% sealed seam process provides maximum fluid resistance and minimum risk exposure. It is made with a fluid-resistant breathable vent and is available with or without built-in pillow(s). The SEG-MAX Pinnacle is rated for clients up to 250lbs.

Materials: (Must Include)

- 1) Dimensional Stability (Warranty against cracking)
- 2) Cover is polyurethane coated 1680 denier ballistic rip-stop fabric
- 3) Flame Retardant
- 4) Virus Barrier
- 5) Washable – See Our Cleaning Instructions
- 6) Abrasion Resistant
- 7) Cover is hypoallergenic- latex free

Construction: (Must Include)

- 1) 100% Sealed Seams (Additional Security Stitch- TEX 176 Nylon Thread)
- 2) Breathable Vent (Must resist water, oil, urine, blood, head lice, bed bugs)
- 3) Optional Integrated pillow(s) constructed of solid fiber- Zero loose fill pillow batting
- 4) Seam Strength average breaking force 336 lbf
- 5) Core must be foam
- 6) Fire Barrier
- 7) Thickness to be 6 inches.
- 8) Completed mattress to contain no manufacturing byproduct such as polypropylene film, silk film, or other foreign material detrimental to a secure area.

Features (Must Perform These Tests)

- 1) Flammability testing must meet the requirements of:
 - A) 16 CFR part 1632.4
 - B) 16 CFR part 1633
- 2) Seam Strength Testing ASTM D5034

Complete Mattress

NOTE: Acceptable industry standard tolerances for finished mattress dimensions are +/- 1in (+/-2.5cm)

Note: This information is furnished for reference purposes only. In order to manufacture to these specifications, one must obtain written permission from Derby Industries.



24350 State Road 23 South, South Bend IN 46614

Tel: (866)233-4500

Fax: (574)288-4550

Mattresses: www.derbyindustries.com

Email: sales @derbyindustries.com

Product Specifications for the Derby CLR Clear Vinyl Fiber Mattress

The Derby CLR Clear Vinyl Fiber Mattress is produced by special manufacturing techniques. The 100% sealed seam process provides maximum fluid resistance as well as minimum risk exposure. It is made with a fluid-resistant breathable vent and is available with or without a built-in pillow.

Cover

- 11oz. glass clear correctional fabric
- Transparency makes it difficult to conceal contraband
- Increases safety/security of staff and inmate population
- Highly durable polyester reinforced base fabric
- Strong and tear resistant
- Bacterial/fungal resistant
- Fluid and stain resistant
- Non-allergenic
- Easily cleaned with soap and water
- Malodor protection
- Anti static
- 100% Sealed Seams lock out blood, water, urine, bed bugs, & head lice

Core

- Core must be full overall length of the mattress, including head rest area, 100% polyester fiber, minimum of 11 oz
- Available with or without integrated pillow(s)
- Optional integrated pillows constructed of solid fiber- Zero loose fill pillow batting
- Pillows are laminated to a full length mattress core to ensure they remain in place
- Core contains no hazardous chemical byproducts- 100% recyclable "green"
- Core is hypoallergenic- latex free
- Thickness to be 4 inches.
- Completed mattress to contain no manufacturing byproduct such as polypropylene film, silk film, or other foreign material detrimental to a secure area.
- Meets Cal 117, Cal 121, Cal 129, 16 CFR parts 1632 & 1633 flammability requirements

Complete Mattress

NOTE: Acceptable industry standard tolerances for finished mattress dimensions are +/- 1in (+/-2.5cm)

Note: This information is furnished for reference purposes only. In order to manufacture to these specifications, one must obtain written permission from Derby Industries.

August 1, 2019



24350 State Road 23 South, South Bend IN 46614

Tel: (866)233-4500

Fax: (574)288-4550

Mattresses: www.derbyindustries.com

Email: sales @derbyindustries.com

Product Specifications for the Derby Blue Standard Correctional Mattress

The Derby Correctional Mattress is produced by special manufacturing techniques. The 100% sealed seam process provides maximum fluid resistance as well as minimum risk exposure. It comes with a fluid-resistant breathable vent and is available with or without a built-in pillow.

Materials: (Must Include)

- 1) Dimensional Stability (Warranty against cracking)
- 2) Flame Retardant
- 3) Odor-Resistant
- 4) Antimicrobial properties built in to protect the product
- 5) Virus Barrier
- 6) Moisture Vapor Permeable
- 7) Washable – See Our Cleaning Instructions
- 8) Abrasion Resistant
- 9) Cover is hypoallergenic – latex free

Construction: (Must Include)

- 1) 100% Sealed Seams (Absolutely No Stitching)
- 2) Breathable Vent (Must resist water, oil, urine, blood, head lice, bed bugs)
- 3) Integrated Pillow constructed of solid fiber – Zero loose fill pillow batting
- 4) Seam Strength average breaking force 116 lbf
- 5) Core must be full overall length of the mattress, including head rest area, 100% densified polyester, minimum of 11 oz/sq. ft. density
- 6) Core contains no hazardous chemical byproducts- 100% recyclable “green”
- 7) Core is hypoallergenic- latex free
- 8) Thickness to be 4 inches
- 9) Completed mattress to contain no manufacturing byproduct such as polypropylene film, silk film, or other foreign material detrimental to a secure area

Features (Must Perform These Tests)

- 1) Flammability testing must meet and exceed the requirements of:
 - A) 16 CFR 1632
 - B) 16 CFR 1633
- 2) Life Cycle Test: Must pass rolator test of 100,000 cycles with minimum loss of density and no cover damage.
- 3) Seam Strength Testing ASTM D5034

Complete Mattress

NOTE: Acceptable industry standard tolerances for finished mattress dimensions are +/- 1in (+/-2.5cm)

Note: This information is furnished for reference purposes only. In order to manufacture to these specifications, one must obtain written permission from Derby Industries.

August 1, 2019



24350 State Road 23 South, South Bend IN 46614
Toll Free: (866)233-4500 Fax: (574)288-4550
Mattresses: www.derbyindustries.com
Email: sales @derbyindustries.com

Product Specifications for the Derby SEG-MAX Mattress

The Derby SEG-MAX Mattress is produced by special manufacturing techniques. The 100% sealed seam process provides maximum fluid resistance as well as minimum risk exposure. It is made with a fluid-resistant breathable vent and is available with or without a built-in pillow(s).

Materials: (Must Include)

- 1) Dimensional Stability (Warranty against cracking)
- 2) Cover is polyurethane (double) coated 1680 Denier ballistic nylon rip-stop fabric
- 3) Flame Retardant
- 4) Virus Barrier
- 5) Washable – See Our Cleaning Instructions
- 6) Abrasion Resistant
- 7) Cover is hypoallergenic- latex free

Construction: (Must Include)

- 1) 100% Sealed Seams (Additional Security Stitch- TEX 176 Nylon Thread)
- 2) Breathable Vent (Must resist water, oil, urine, blood, head lice, bed bugs)
- 3) Integrated pillow constructed of solid fiber- Zero loose fill pillow batting
- 4) Seam Strength average breaking force 336 lbf
- 5) Core must be full overall length of the mattress, including head rest area, 100% densified polyester, minimum of 11 oz/sq. ft. density
- 6) Core contains no hazardous chemical byproducts- 100% recyclable “green”
- 7) Core is hypoallergenic- latex free
- 8) Thickness to be 4 inches.
- 9) Completed mattress to contain no manufacturing byproduct such as polypropylene film, silk film, or other foreign material detrimental to a secure area.

Features (Must Perform These Tests)

- 1) Flammability testing must meet and exceed the requirements of:
 - A) California Technical Bulletin 117
 - B) 16 CFR part 1632.4
 - C) 16 CFR part 1633
- 2) Seam Strength Testing ASTM D5034

Complete Mattress

NOTE: Acceptable industry standard tolerances for finished mattress dimensions are +/- 1in (+/-2.5cm)

Note: This information is furnished for reference purposes only. In order to manufacture to these specifications, one must obtain written permission from Derby Industries.

August 1, 2019