



Submitted to
The Dow Chemical Company
1790 Building
Midland, MI 48667

Submitted by
AECOM
25 Building
Midland, MI 48667
01/31/2020

2019 Corrective Action Implementation Summary Report
and 2020 Work Plan
The Dow Chemical Company
Midland Plant
EPA ID: MID 000 724 724

Table of Contents

EXECUTIVE SUMMARY

1.0	INTRODUCTION.....	1-1
2.0	GOALS AND OBJECTIVES FOR LICENSE PERIOD.....	2-1
2.1	Achieve Control of Human Exposures.....	2-1
2.1.1	Soil Direct Contact	2-2
2.1.2	Indoor Air	2-3
2.1.3	On-Site Outdoor Air.....	2-5
2.1.4	Soil Volatilization to Ambient Air	2-5
2.1.5	Particulate Soil Inhalation.....	2-5
2.2	Sustain Control of Contaminated Groundwater	2-6
2.3	Remedy Implementation for AOCs.....	2-6
2.4	Additional Source Control Measures for Mobile Free Phase Liquids.....	2-7
2.5	2019 Releases to Soil.....	2-7
2.6	Priority Actions Completed in 2019	2-7
3.0	SOURCE CONTROL MEASURES.....	3-1
3.1	1925 Landfill.....	3-1
3.2	B-Sewer Manhole (MH) B108 AOC.....	3-1
4.0	RGIS UPGRADES	4-1
5.0	MIDLAND PLANT FACILITY-WIDE VAPOR INTRUSION PATHWAY.....	5-1
5.1	VI Pathway Methodology and Program Update.....	5-1
5.1.1	Site-Wide VI Sampling and Evaluation Program Update.....	5-3
5.1.2	VI Sampling Status Summary.....	5-9
5.2	Zone 1 Evaluations and Updates	5-14
5.2.1	Building 34 Interim Monitoring Results Summary.....	5-14
5.2.2	Building 1335 Interim Monitoring Results Summary.....	5-15
5.2.3	Building 462 Interim Monitoring Results Summary.....	5-16
5.2.4	VI Seasonal Confirmation Sampling Results Evaluation for Building 680	5-16
5.2.5	Building 838 Interim Monitoring Results Summary.....	5-38
5.2.6	Vapor Intrusion Evaluation for Building 1098	5-38
5.2.7	Vapor Intrusion Evaluation Summary for Building 1159	5-41
5.3	Zone 2 Phase 1 Evaluations	5-43
5.3.1	Vapor Intrusion Evaluation Summary for Building 833	5-43
5.3.2	VI Seasonal Confirmation Sampling Results Evaluation for Building 941	5-44
5.3.3	VI Seasonal Confirmation Sampling Results Evaluation for Building 1028.....	5-68
5.3.4	VI Seasonal Confirmation Sampling Results Evaluation for Building 1233.....	5-75
5.3.5	VI Seasonal Confirmation Sampling Results Evaluation for Building 827	5-86
5.3.6	VI Seasonal Confirmation Sampling Results Evaluation for Building 948	5-101
5.3.7	Vapor Intrusion Evaluation for Building 1025	5-117
5.3.8	VI Seasonal Confirmation Sampling Results Evaluation for Building 768	5-119
5.3.9	VI Seasonal Confirmation Sampling Results Evaluation for Building 849	5-127
5.3.10	VI Seasonal Confirmation Sampling Results Evaluation for Building 858	5-134
5.3.11	VI Seasonal Confirmation Sampling Results Evaluation for Building 969	5-150
5.3.12	VI Seasonal Confirmation Sampling Results Evaluation for Building 1222.....	5-163
5.4	Zone 2 Phase 2 Evaluations	5-176
5.4.1	VI Seasonal Confirmation Sampling Results Evaluation for Building 1255.....	5-176
5.4.2	VI Seasonal Confirmation Sampling Results Evaluation for Building 304	5-186
5.4.3	VI Seasonal Confirmation Sampling Results Evaluation for Building 499	5-208
5.4.4	VI Seasonal Confirmation Sampling Results Evaluation for Building 593	5-224

5.4.5	VI Seasonal Confirmation Sampling Results Evaluation for Building 826/494	5-242
5.4.6	Vapor Intrusion Evaluation Summary for Building 921	5-252
5.4.7	VI Seasonal Confirmation Sampling Results Evaluation for Building 923	5-254
5.4.8	Vapor Intrusion Evaluation for Building 935	5-270
5.5	Zone 3 Phase 1 Buildings	5-273
5.5.1	Vapor Intrusion Evaluation for Building 800	5-273
5.5.2	Vapor Intrusion Evaluation for Building 887	5-275
5.5.3	Vapor Intrusion Evaluation for Building 954	5-280
5.5.4	Vapor Intrusion Evaluation for Building 1038	5-281
5.5.5	Vapor Intrusion Evaluation for Building 1131	5-283
5.5.6	Vapor Intrusion Evaluation for Building 100	5-285
5.5.7	VI Seasonal Confirmation Sampling Results Evaluation for Building 564	5-287
5.5.8	Vapor Intrusion Evaluation for Building 881	5-302
5.5.9	Vapor Intrusion Evaluation for Building 1037	5-307
5.5.10	Vapor Intrusion Evaluation for Building 1042	5-309
5.6	Zone 3 Phase 2 Buildings	5-312
5.6.1	Building 734	5-312
5.6.2	Building 938	5-313
5.6.3	Building 990	5-313
5.6.4	Building 1018	5-313
5.6.5	Building 1385	5-314
5.6.6	Building 439/T-1411	5-314
5.6.7	Building 732/1300	5-314
5.6.8	Building 759/1350	5-315
5.6.9	Building 49	5-315
5.6.10	Building 146	5-323
5.6.11	Building 180	5-323
5.6.12	Building 298	5-323
5.6.13	Building 374	5-324
5.6.14	Building 464	5-324
5.6.15	Building 638	5-325
5.6.16	Building 774	5-325
5.6.17	Building 1269	5-325
5.6.18	Building 27/313/803	5-326
5.6.19	Building 458/963	5-326
5.6.20	Building 542/561	5-327
5.6.21	Building 719/1360	5-328
5.7	Zone 3 Phase 3 Buildings	5-329
5.7.1	Building 25	5-330
5.7.2	Building 354	5-330
5.7.3	Building 433A	5-331
5.7.4	Building 574	5-331
5.7.5	Building 608	5-332
5.7.6	Building 845	5-332
5.7.7	Building 1319	5-332
5.7.8	Building 1354	5-333
5.7.9	Building 1616	5-333
5.7.10	Building 695	5-333
5.7.11	Building 856	5-334
5.7.12	Building 872	5-334
5.7.13	Building 1302	5-335
5.7.14	Building 1351	5-335
5.7.15	Building 433W	5-335
5.7.16	Building 433B	5-336

6.0	DIRECT CONTACT TO SOIL PATHWAY.....	6-1
6.1	Direct Contact Exposure Characterization.....	6-1
6.2	Target Analyte Lists and Sampling Density	6-2
6.3	Sampling Methodology	6-3
6.3.1	Incremental Sampling Methodology.....	6-3
6.3.2	Decision Unit Determination	6-3
6.3.3	Sample Collection	6-4
6.3.4	Field Documentation	6-5
6.3.5	Equipment Decontamination	6-5
6.3.6	Sample Processing and Laboratory Analysis.....	6-6
6.4	Statistical Evaluation and Screening of Data.....	6-6
6.5	Zone 1, Campus Area, and Greenbelt Areas Direct Contact to Soil Pathway Summary.....	6-7
6.5.1	Zone 1 Interim Measure/Long-Term Barrier Design Sampling.....	6-8
6.5.2	Additional Zone 1 DUs Request by EGLE.....	6-8
6.6	Zone 2 Direct Contact to Soil Pathway Summary.....	6-9
6.6.1	Zone 2 Direct Contact to Soil Pathway Summary for 2019 DUs	6-11
6.7	Zone 3 Direct Contact to Soil Pathway Summary	6-11
6.8	Evaluation of Dioxins and Furans Replicate Sampling From Zone 1 and Zone 2	6-12
6.9	Arsenic Replicate Sampling.....	6-13
6.10	Zone 4 Direct Contact to Soil Pathway.....	6-13
6.10.1	Zone 4 Characterization.....	6-13
6.10.2	2019 Zone 4 Direct Contact Sampling Results and Evaluation.....	6-14
6.10.2.1	Category 1 – Laydown Areas and Historical Areas Operations (Gravel Areas)	6-14
6.10.2.2	Category 2 – Historic Grass and Gravel Areas	6-14
6.10.2.3	Category 5 – Stormwater Basin	6-14
6.10.2.4	Category 6 – Vegetated Cap Closed by Dow	6-15
6.10.3	Zone 4 Results Evaluation.....	6-15
6.10.4	Zone 4 Summary and Recommendations.....	6-15
6.11	2019 Replicate Sampling Evaluation.....	6-15
6.12	Dioxins and Furans TEQ UCL Evaluations.....	6-18
6.12.1	Zone 1 Dioxins and Furans TEQ UCLs Evaluation	6-18
6.12.2	Zone 2 Dioxins and Furans TEQ UCLs Evaluation	6-19
6.12.3	Zone 3 Dioxins and Furans TEQ UCLs Evaluation	6-19
6.12.4	Zone 4 Dioxins and Furans TEQ UCLs Evaluation	6-19
6.13	Category 5 Stormwater Basin CSM Evaluation	6-19
6.13.1	2019 Sampling Results	6-20
6.13.2	Conclusion.....	6-20
6.14	Direct Contact Interim Measures and Long-Term Barriers.....	6-21
6.14.1	Zone 1 Interim Measures and Long-Term Barriers.....	6-21
6.14.1.1	Pallet Yard Area (DUs 1A-2 through 1A-8).....	6-22
6.14.1.2	Additional Category 1 DUs Near Pallet Yard Area	6-23
6.14.1.3	Zone 1 DUs 2D and 4C.....	6-23
6.14.2	Zone 2 Interim Measures and Long-Term Barriers.....	6-24
6.14.2.1	Eastern Zone 2 Long-Term Barrier (499 Area)	6-24
6.14.2.2	Western Zone 2 Long-Term Barrier.....	6-25
6.14.3	Zone 3 Interim Measures and Long-Term Barriers.....	6-26
6.14.4	Zone 4 and Stormwater Basin CSM Interim Measures.....	6-27
6.15	Year 5 Direct Contact Goals	6-28
6.15.1	Zone 5 Tittabawassee River Floodplain Area Conceptual Site Model and Sampling Methodology.....	6-28
6.15.1.1	Tittabawassee River Flood Plain Conceptual Site Model	6-28
6.15.1.2	Tittabawassee River Flood Plain Sampling Methodology.....	6-28
6.15.2	Additional Dioxins and Furans Sampling in Zones 1 through 4.....	6-30
7.0	ON-SITE OUTDOOR AIR PATHWAY	7-1

7.1	Soil Volatilization to Ambient Air.....	7-1
7.2	Particulate Soil Inhalation	7-2
7.3	Conclusions and Recommendations.....	7-2
8.0	SLUDGE DEWATERING FACILITY	8-1
8.1	Overview of Site Characterization and Interim Measures	8-1
8.1.1	CSM Development & Groundwater Modeling/Pilot Study 2018	8-2
8.2	Work in 2019.....	8-2
8.3	Path Forward.....	8-3
9.0	POSEYVILLE LANDFILL.....	9-1
9.1	Overview of Site Characterization and Interim Measures	9-1
9.2	Northeast Corner	9-2
9.2.1	Purge Well Optimization Pilot	9-2
9.2.2	2019 Status of Purge Well Optimization Pilot.....	9-3
9.3	Leachate Collection System and Slurry Wall Upgrades	9-4
9.4	Upgrades in 2019	9-5
9.5	Path Forward.....	9-5
10.0	NORTHEAST PERIMETER	10-1
10.1	Overview of Site Characterization and Interim Measures	10-1
10.2	Conceptual Site Models.....	10-3
10.2.1	6178 Area	10-3
10.2.2	6175 Area	10-3
10.2.3	CFC Area.....	10-3
10.3	Current Status	10-4
10.4	Path Forward.....	10-4
11.0	CHEMICAL DISPOSAL WELL #3.....	11-1
11.1	Overview of Site Characteristics and Interim Measures.....	11-1
11.1.1	Work Completed in 2018.....	11-2
11.2	Work in 2019.....	11-2
11.2.1	Assessment of 2016 and 2018 Shallow Groundwater Data.....	11-2
11.2.1.1	Hydraulic Conductivity Assessment	11-3
11.2.1.2	Deep Well Chloride Impact Assessment.....	11-3
11.2.2	Shallow Groundwater Monitoring Program Development and Implementation	11-4
11.3	Path Forward.....	11-4
12.0	7 TH STREET PURGE WELLS AREA (FUEL OIL TANK FARM)	12-1
12.1	Overview of Site Characterization and Interim Measures	12-1
12.1.1	Shallow Zone Interim Measures	12-1
12.2	Shallow Zone Current Status	12-2
12.2.1	Work in 2019.....	12-2
12.3	Path Forward.....	12-3
13.0	MARK PUTNAM ROAD AOC	13-1
13.1	Summary of Initial Conditions	13-1
13.2	Work in 2019.....	13-2
13.2.1	Fieldwork	13-2
13.2.1.1	Soil Borings	13-2
13.2.1.2	Groundwater Investigation	13-3
13.2.1.3	Direct Contact Investigation	13-3
13.2.2	Data Analysis.....	13-3
13.2.2.1	Soil Investigation Results.....	13-3
13.2.2.2	Groundwater Investigation Results.....	13-3

13.3	Path Forward.....	13-4
14.0	FORMER ASH POND AOC	14-1
14.1	Overview of Site Characterization and Interim Measures	14-1
14.2	Current Status.....	14-2
14.2.1	Work in 2019.....	14-2
14.3	Path Forward.....	14-4
14.3.1	Seep Investigation and General Chemistry Data Collection	14-4
14.3.1.1	Seep Investigation Methodology	14-4
14.3.1.2	General Chemistry Parameter and Stiff Diagrams	14-5
15.0	B-SEWER MANHOLE B108 AOC	15-1
15.1	Site History.....	15-1
15.2	Site Conditions and 2018 Source Area Investigation Findings.....	15-1
15.3	Results of Bench Scale Study.....	15-2
15.4	2019 Pilot Study Design	15-3
15.4.1	Pilot Study – Soil.....	15-4
15.4.2	Pilot Study – Groundwater.....	15-5
15.4.3	Pilot Study – MH B108.....	15-6
15.4.4	Pilot Study- DNAPL.....	15-6
15.4.5	April 2019 Injection Event.....	15-7
15.5	2019 Pilot Study – Results to Date.....	15-7
15.5.1	DNAPL	15-8
15.5.2	Soil	15-8
15.5.3	Groundwater	15-10
15.5.3.1	Analytical Findings - Groundwater.....	15-10
15.5.3.2	Hydrogeological Findings.....	15-11
15.5.4	MH B108 – Sewer.....	15-12
15.6	Summary of Pilot Study to Date	15-13
15.7	MH B108 AOC Work for 2020.....	15-14
16.0	OVERLOOK PARK AND 13S.....	16-1
16.1	Overview of Site Characterization and Interim Measures	16-1
16.2	Current Status and Path Forward.....	16-4
17.0	2020 CONCEPTUAL SCHEDULE.....	17-1
18.0	REFERENCES	18-1

List of Appendices

Appendix A	Analytical Data for Fall 2018 through Summer 2019
Appendix B	Field Sampling Logs for Fall 2018 through Summer 2019
Appendix C	Further Investigation Reports
Appendix D	Zone 3 Building Surveys and Chemical Inventory
Appendix E	Direct Contact Decision Unit Maps
Appendix F	Direct Contact Analytical Lab Reports
Appendix G	PLF North Tile Construction Drawings
Appendix H	7 th Street Purge Well Area 2019 Boring Logs
Appendix I	Ash Pond GSI Compliance June 2019 Meeting Slides
Appendix J	Ash Pond Conceptual Site Model Development
Appendix K	Provect-GS [®] B-Sewer Treatability Study
Appendix L	B-Sewer Groundwater Injection Permit Exemption
Appendix M	B-Sewer Lab Reports By Matrix
Appendix N	B-Sewer Field Forms
Appendix O	B-Sewer Boring Logs
Appendix P	B-Sewer Slug Test Information
Appendix Q	IET B-Sewer Injection Report

List of Tables

Table 1-1	20020 Update of Table B2-1 – Summary of Potential or Actual Sources of Contamination
Table 1-2	Crosswalk of 2019/2020 CAIP Updated WMU/AOC Numbers
Table 2-1.	2019/2020 CAIP Update of Table B2-4
Table 5-1	Buildings Categorized to Date
Table 5-2	Path Forward Building Group Notification and Reporting
Table 5.2.4-A	Building 680 Summary Statistics and Screening Comparison for Sub-Slab Soil Gas
Table 5.2.4-B	Building 680 Summary Statistics and Screening Comparison for Indoor Air and Outdoor Air
Table 5.2.6-A	Building 1098 Summary Statistics and Screening Comparison for Sub-Slab Soil Gas
Table 5.2.6-B	Building 1098 Summary Statistics and Screening Comparison for Indoor Air and Outdoor Air
Table 5.2.7-A	Building 1159 Summary Statistics and Screening Comparison for Sub-Slab Soil Gas
Table 5.2.7-B	Building 1159 Summary Statistics and Screening Comparison for Indoor Air and Outdoor Air
Table 5.3.1-A	Building 833 Summary Statistics and Screening Comparison for Sub-Slab Soil Gas
Table 5.3.1-B	Building 833 Summary Statistics and Screening Comparison for Indoor Air and Outdoor Air
Table 5.3.2-A	Building 941 Summary Statistics and Screening Comparison for Sub-Slab Soil Gas
Table 5.3.2-B	Building 941 Summary Statistics and Screening Comparison for Indoor Air and Outdoor Air
Table 5.3.3-A	Building 1028 Summary Statistics and Screening Comparison for Sub-Slab Soil Gas
Table 5.3.3-B	Building 1028 Summary Statistics and Screening Comparison for Indoor Air and Outdoor Air
Table 5.3.4-A	Building 1233 Summary Statistics and Screening Comparison for Sub-Slab Soil Gas
Table 5.3.4-B	Building 1233 Summary Statistics and Screening Comparison for Indoor Air and Outdoor Air
Table 5.3.5-A	Building 827 Summary Statistics and Screening Comparison for Sub-Slab Soil Gas
Table 5.3.5-B	Building 827 Summary Statistics and Screening Comparison for Indoor Air and Outdoor Air
Table 5.3.6-A	Building 948 Summary Statistics and Screening Comparison for Sub-Slab Soil Gas
Table 5.3.6-B	Building 948 Summary Statistics and Screening Comparison for Indoor Air and Outdoor Air
Table 5.3.7-A	Building 1025 Summary Statistics and Screening Comparison for Sub-Slab Soil Gas
Table 5.3.7-B	Building 1025 Summary Statistics and Screening Comparison for Indoor Air and Outdoor Air
Table 5.3.8-A	Building 768 Summary Statistics and Screening Comparison for Sub-Slab Soil Gas
Table 5.3.8-B	Building 768 Summary Statistics and Screening Comparison for Indoor Air and Outdoor Air
Table 5.3.9-A	Building 849 Summary Statistics and Screening Comparison for Sub-Slab Soil Gas
Table 5.3.9-B	Building 849 Summary Statistics and Screening Comparison for Indoor Air and Outdoor Air
Table 5.3.10-A	Building 858 Summary Statistics and Screening Comparison for Sub-Slab Soil Gas
Table 5.3.10-B	Building 858 Summary Statistics and Screening Comparison for Indoor Air and Outdoor Air
Table 5.3.11-A	Building 969 Summary Statistics and Screening Comparison for Sub-Slab Soil Gas
Table 5.3.11-B	Building 969 Summary Statistics and Screening Comparison for Indoor Air and Outdoor Air
Table 5.3.12-A	Building 1222 Summary Statistics and Screening Comparison for Sub-Slab Soil Gas
Table 5.3.12-B	Building 1222 Summary Statistics and Screening Comparison for Indoor Air and Outdoor Air
Table 5.4.1-A	Building 1255 Summary Statistics and Screening Comparison for Sub-Slab Soil Gas
Table 5.4.1-B	Building 1255 Summary Statistics and Screening Comparison for Indoor Air and Outdoor Air
Table 5.4.2-A	Building 304 Summary Statistics and Screening Comparison for Sub-Slab Soil Gas
Table 5.4.2-B	Building 304 Summary Statistics and Screening Comparison for Indoor Air and Outdoor Air
Table 5.4.3-A	Building 499 Summary Statistics and Screening Comparison for Sub-Slab Soil Gas
Table 5.4.3-B	Building 499 Summary Statistics and Screening Comparison for Indoor Air and Outdoor Air
Table 5.4.4-A	Building 593 Summary Statistics and Screening Comparison for Sub-Slab Soil Gas

Table 5.4.4-B	Building 593 Summary Statistics and Screening Comparison for Indoor Air and Outdoor Air
Table 5.4.5-A	Building 826/494 Summary Statistics and Screening Comparison for Sub-Slab Soil Gas
Table 5.4.5-B	Building 826/494 Summary Statistics and Screening Comparison for Indoor Air and Outdoor Air
Table 5.4.6-A	Building 921 Summary Statistics and Screening Comparison for Sub-Slab Soil Gas
Table 5.4.6-B	Building 921 Summary Statistics and Screening Comparison for Indoor Air and Outdoor Air
Table 5.4.7-A	Building 923 Summary Statistics and Screening Comparison for Sub-Slab Soil Gas
Table 5.4.7-B	Building 923 Summary Statistics and Screening Comparison for Indoor Air and Outdoor Air
Table 5.4.8-A	Building 935 Summary Statistics and Screening Comparison for Sub-Slab Soil Gas
Table 5.4.8-B	Building 935 Summary Statistics and Screening Comparison for Indoor Air and Outdoor Air
Table 5.5.1-A	Building 800 Summary Statistics and Screening Comparison for Sub-Slab Soil Gas
Table 5.5.1-B	Building 800 Summary Statistics and Screening Comparison for Indoor Air and Outdoor Air
Table 5.5.2-A	Building 887 Summary Statistics and Screening Comparison for Sub-Slab Soil Gas
Table 5.5.2-B	Building 887 Summary Statistics and Screening Comparison for Indoor Air and Outdoor Air
Table 5.5.3-A	Building 954 Summary Statistics and Screening Comparison for Sub-Slab Soil Gas
Table 5.5.3-B	Building 954 Summary Statistics and Screening Comparison for Indoor Air and Outdoor Air
Table 5.5.4-A	Building 1038 Summary Statistics and Screening Comparison for Sub-Slab Soil Gas
Table 5.5.4-B	Building 1038 Summary Statistics and Screening Comparison for Indoor Air and Outdoor Air
Table 5.5.5-A	Building 1131 Summary Statistics and Screening Comparison for Sub-Slab Soil Gas
Table 5.5.5-B	Building 1131 Summary Statistics and Screening Comparison for Indoor Air and Outdoor Air
Table 5.5.6-A	Building 100 Summary Statistics and Screening Comparison for Sub-Slab Soil Gas
Table 5.5.6-B	Building 100 Summary Statistics and Screening Comparison for Indoor Air and Outdoor Air
Table 5.5.7-A	Building 564 Summary Statistics and Screening Comparison for Sub-Slab Soil Gas
Table 5.5.7-B	Building 564 Summary Statistics and Screening Comparison for Indoor Air and Outdoor Air
Table 5.5.8-A	Building 881 Summary Statistics and Screening Comparison for Sub-Slab Soil Gas
Table 5.5.8-B	Building 881 Summary Statistics and Screening Comparison for Indoor Air and Outdoor Air
Table 5.5.9-A	Building 1037 Summary Statistics and Screening Comparison for Sub-Slab Soil Gas
Table 5.5.9-B	Building 1037 Summary Statistics and Screening Comparison for Indoor Air and Outdoor Air
Table 5.5.10-A	Building 1042 Summary Statistics and Screening Comparison for Sub-Slab Soil Gas
Table 5.5.10-B	Building 1042 Summary Statistics and Screening Comparison for Indoor Air and Outdoor Air
Table 5.6.9-A	Building 49 Summary Statistics and Screening Comparison for Sub-Slab Soil Gas
Table 5.6.9-B	Building 49 Summary Statistics and Screening Comparison for Indoor Air and Outdoor Air
Table 6-1	Midland Plant Soil Relocations
Table 6-2	Relocation of Soil to Michigan Operations Soil Greater than 990 ppt
Table 6-3	Direct Contact Land Use Categories
Table 6-4	Target Analyte Lists for Direct Contact Sources
Table 6-5	Laboratories and Methods Used to Analyze for Target Analytes
Table 6-6	Summed Isomer Specific Analytes
Table 6-7	Additional Zone 2 DUs Dioxins and Furans TEQ Summary Statistics and Screening Comparison
Table 6-8	Additional Zone 2 DUs Dioxins and Furans TEQ by DU
Table 6-9	Additional Zone 2 DUs Metals Background Summary Statistics and Screening Comparison
Table 6-10	Additional Zone 2 DUs Totals Summary Statistics and Screening Comparison
Table 6-11	Additional Zone 2 Category 1 DUs Non-Dioxin Summary Statistics and Screening Comparison
Table 6-12	Zone 1 2017 Dioxins and Furans Triplicate Sampling Results
Table 6-13	Zone 2 2018 Dioxins and Furans Triplicate Sampling Results
Table 6-14	95% Lower Bound Determination of Midland FAST Analysis – Zones 1 and 2
Table 6-15	Summary of Fall 2019 Direct Contact Sampling

Table 6-16	Zone 4 Direct Contact Sampling Decision Units
Table 6-17	Direct Contact Sampling Plan – Decision Units Modified or Not Sampled
Table 6-18	Zone 4 Dioxins and Furans TEQ Summary Statistics and Screening Comparison
Table 6-19	Zone 4 Dioxins and Furans TEQ by DU
Table 6-20	Zone 4 Metals Background Summary Statistics and Screening Comparison
Table 6-21	Zone 4 Totals Summary Statistics and Screening Comparison
Table 6-22	Zone 4 Category 1 Non-Dioxin Summary Statistics and Screening Comparison
Table 6-23	Zone 4 Category 2 Non-Dioxin Summary Statistics and Screening Comparison
Table 6-24	Zone 4 Category 5 Non-Dioxin Summary Statistics and Screening Comparison
Table 6-25	Zone 4 Category 6 Non-Dioxin Summary Statistics and Screening Comparison
Table 6-26	Dioxins and Furans Replicate Analysis Summary
Table 6-27	95% Lower Bound Determination of Midland FAST Analysis – Zones 1 through 4
Table 6-28	Zone 3 2019 Dioxins and Furans Triplicate Sampling Results
Table 6-29	Zone 4 2019 Dioxins and Furans Triplicate Sampling Results
Table 6-30	Zone 1 through Zone 4 UCL Evaluation
Table 6-31	Updated Zone 1 through 5 Dioxins and Furans TEQ Summary Statistics and Screening Comparison
Table 6-32	Category 5 Stormwater Basin CSM Confirmation Dioxins and Furans TEQ Summary Statistics and Screening Comparison
Table 6-33	Category 5 Stormwater Basin CSM Confirmation Dioxins and Furans TEQ by DU
Table 6-34	Category 5 Stormwater Basin CSM Confirmation Metals Background Comparison
Table 6-35	Category 5 Stormwater Basin CSM Confirmation Total Screening Comparison
Table 6-36	Category 5 Stormwater Basin CSM Confirmation Non-Dioxin Summary Statistics and Screening Comparison
Table 6-37	Summary of Direct Contact Interim Measures and Long-Term Barriers
Table 7-1	Zone 4 Category 1 Summary Statistics and Screening Comparison
Table 7-2	Zone 4 Categories 2, 5, and 6 Summary Statistics and Screening Comparison
Table 7-3	2019 Stormwater Basin Confirmation Sampling Summary Statistics and Screening Comparison
Table 7-4	Zone 4 Category 1 Summary Statistics and Screening Comparison for 2,3,7,8-TCDD
Table 7-5	Zone 4 Categories 2, 5, and 6 Summary Statistics and Screening Comparison for 2,3,7,8-TCDD
Table 7-6	2019 Stormwater Basin CSM and Zone 3 Confirmation Sampling Summary Statistics and Screening Comparison for 2,3,7,8-TCDD
Table 9-1	2018 Average Pump and Daily Flow Rates for 2690A and 2917
Table 9-2	2019 Average Pump and Daily Flow Rates 2690A and 2917
Table 9-3	Plume Trends – Poseyville Landfill Purge Well Optimization Study
Table 11-1	Summary of Detections for CD-3 Shallow Groundwater - First Quarter
Table 11-2	Summary of Detections for CD3 Shallow Ground Water - First Quarter 2018
Table 11-3	Summary of Detections for CD-3 Deep Groundwater - First Quarter 2016
Table 11-4	Summary of Detections for CD3 Deep Ground Water - March 2018
Table 11-5	CD-3 GSI Short Term Monitoring Analyte List
Table 11-6	CD-3 GSI Monitoring Groundwater Sample Results
Table 13-1	South of Mark Putnam Road Soil Testing Results
Table 13-2	Mark Putnam Soil Analytical Results
Table 13-3	Mark Putnam Groundwater Analytical Results
Table 14-1	Ash Pond Well Inventory, Survey, and water Elevation Data
Table 15-1.	VOCs and SVOCs Detected in DNAPL – B-Sewer MH B108 AOC 2018 Investigation
Table 15-2.	Dioxins/Furans Detected in DNAPL – B-Sewer MH B108 AOC 2018 Investigation
Table 15-3.	B-Sewer MH B108 AOC ISGS Pilot Study Monitoring Schedule
Table 15-4	VOCs Detected in DNAPL Samples Collected from 9428 – B-Sewer MH B108 AOC ISGS Pilot Study

Table 15-5	SVOCs Detected in DNAPL Samples Collected from 9428 – B-Sewer MH B108 AOC ISGS Pilot Study
Table 15-6	2,3,7,8-TCDD Concentrations and 2,3,7,8-TCDD TEC Values in 9428 DNAPL Samples – B-Sewer MH B108 ISGS Pilot Study
Table 15-7.	VOC/SVOC COIs in Baseline Soil Samples – B-Sewer MH B108 AOC ISGS Pilot Study
Table 15-8.	Detected Metals in Baseline Soil Samples – B-Sewer MH B108 AOC ISGS Pilot Study
Table 15-9.	2,3,7,8-TCDD Concentrations and 2,3,7,8-TCDD TEC in Baseline Soil Samples – B-Sewer MH B108 AOC ISGS Pilot Study
Table 15-10	VOC COIs in Groundwater – B-Sewer MH B108 AOC ISGS Pilot Study
Table 15-11	SVOC COIs in Groundwater – B-Sewer MH B108 AOC ISGS Pilot Study
Table 15-12	2,3,7,8-TCDD Concentrations and 2,3,7,8-TCDD TEC Values in Groundwater – B-Sewer MH B108 AOC ISGS Pilot Study
Table 15-13.	Detected Metals in Groundwater – B-Sewer MH B108 AOC ISGS Pilot Study
Table 15-14	Estimated Permanganate Concentrations in Groundwater – B-Sewer MH B108 AOC Pilot Study
Table 15-15	Baseline Slug Test Results (March 2019) – B-Sewer MH B108 AOC ISGS Pilot Study
Table 15-16	PM#1 Slug Test Results (May 2019) – B-Sewer MH B108 AOC ISGS Pilot Study
Table 15-17	PM#4 Slug Test Results (November 2019) – B-Sewer MH B108 AOC ISGS Pilot Study
Table 15-18	Mass Flux Evaluation Parameters and Assumptions – B-Sewer MH B108 AOC ISGS Pilot Study
Table 15-19	Hydraulic Gradient at MH B108 AOC ISGS Pilot Study Area
Table 15-20	Mass Flux Evaluation through Assumed Transect During Baseline – B-Sewer MH B108 AOC ISGS Pilot Study
Table 15-21	Mass Flux Evaluation through Assumed Transect During PM#1 – B-Sewer MH B108 AOC ISGS Pilot Study
Table 15-22	Mass Flux Evaluation through Assumed Transect During PM#4 – B-Sewer MH B108 AOC ISGS Pilot Study
Table 15-23	MH B108 Results – VOC COIs
Table 15-24	MH B108 Results – SVOC COIs
Table 15-25	2,3,7,8-TCDD Concentrations and 2,3,7,8-TCDD TEC Values at MH B108
Table 15-26	Detected Metal Analytes at MH B108
Table 15-27	Observed Estimated Permanganate Concentrations at MH B108 – B-Sewer MH B108 AOC ISGS Pilot Study
Table 17-1	2020 Corrective Action Workplan Anticipated Milestone Schedule

List of Figures

Figure 1-1	Midland Facility Location
Figure 1-2	Waste Management Areas
Figure 1-3	Areas of Concern
Figure 1-4	Corrective Action Implementation Plan High Level Overview
Figure 2-1	Facility Overview of Direct Contact Geographical Zones
Figure 2-2	VI Facility Zones
Figure 2-3	Vapor Intrusion Building Characterization Flowchart
Figure 2-4	Vapor Intrusion Flow Diagram
Figure 2-5	2019 MiOps Sewer Overflow Areas
Figure 4-1	RGIS East Side Improvements LS #104 to LS #105
Figure 5-1	Facility Zones
Figure 5-2	Vapor Intrusion Building Characterization Flowchart
Figure 5-3	Vapor Intrusion Flow Diagram
Figure 5-4	Site-Specific Chemical Facility Conceptual Site Model - Potential Features

Figure 5.2.4-1	Building 680 Vapor Intrusion Building Location
Figure 5.2.4-2	Building 680 Sample Locations
Figure 5.2.4-3	Building 680 Conceptual Site Model
Figure 5.2.6-1	Building 1098 Vapor Intrusion Building Location
Figure 5.2.6-2	Building 1098 Sample Locations
Figure 5.3.2-1	Building 941 Vapor Intrusion Building Location
Figure 5.3.2-2	Building 941 Sample Locations
Figure 5.3.2-3	Building 941 Conceptual Site Model
Figure 5.3.3-1	Building 1028 Vapor Intrusion Building Location
Figure 5.3.3-2	Building 1028 Sample Locations
Figure 5.3.3-3	Building 1028 Conceptual Site Model
Figure 5.3.4-1	Building 1233 Vapor Intrusion Building Location
Figure 5.3.4-2	Building 1233 Sample Locations
Figure 5.3.4-3	Building 1233 Conceptual Site Model
Figure 5.3.5-1	Building 827 Vapor Intrusion Building Location
Figure 5.3.5-2	Building 827 Sample Locations
Figure 5.3.5-3	Building 827 Conceptual Site Model
Figure 5.3.6-1	Building 948 Vapor Intrusion Building Location
Figure 5.3.6-2	Building 948 Sample Locations
Figure 5.3.6-3	Building 948 Conceptual Site Model
Figure 5.3.7-1	Building 1025 Vapor Intrusion Building Location
Figure 5.3.7-2	Building 1025 Sample Locations
Figure 5.3.8-1	Building 768 Vapor Intrusion Building Location
Figure 5.3.8-2	Building 768 Sample Locations
Figure 5.3.8-3	Building 768 Conceptual Site Model
Figure 5.3.9-1	Building 849 Vapor Intrusion Building Location
Figure 5.3.9-2	Building 849 Sample Locations
Figure 5.3.9-3	Building 849 Conceptual Site Model
Figure 5.3.10-1	Building 858 Vapor Intrusion Building Location
Figure 5.3.10-2	Building 858 Sample Locations
Figure 5.3.10-3	Building 858 Conceptual Site Model
Figure 5.3.11-1	Building 969 Vapor Intrusion Building Location
Figure 5.3.11-2	Building 969 Sample Locations
Figure 5.3.11-3	Building 969 Conceptual Site Model
Figure 5.3.12-1	Building 1222 Vapor Intrusion Building Location
Figure 5.3.12-2	Building 1222 Sample Locations
Figure 5.3.12-3	Building 1222 Conceptual Site Model
Figure 5.4.1-1	Building 1255 Vapor Intrusion Building Location
Figure 5.4.1-2	Building 1255 Sample Locations
Figure 5.4.1-3	Building 1255 Sub-slab Soil Gas and Indoor Air Results for Chloroform
Figure 5.4.1-4	Building 1255 Conceptual Site Model
Figure 5.4.2-1	Building 304 Vapor Intrusion Building Location
Figure 5.4.2-2	Building 304 Sample Locations
Figure 5.4.2-3	Building 304 Conceptual Site Model
Figure 5.4.3-1	Building 499 Vapor Intrusion Building Location
Figure 5.4.3-2	Building 499 Sample Locations
Figure 5.4.3-3	Building 499 Conceptual Site Model
Figure 5.4.4-1	Building 593 Vapor Intrusion Building Location
Figure 5.4.4-2	Building 593 Sample Locations for E1 and E3
Figure 5.4.4-3	Building 593 Sample Locations for E2
Figure 5.4.4-4	Building 593 Conceptual Site Model
Figure 5.4.5-1	Buildings 826/494 Vapor Intrusion Building Location
Figure 5.4.5-2	Buildings 826/494 Sample Locations
Figure 5.4.5-3	Building 826/494 Conceptual Site Model

Figure 5.4.7-1	Building 923 Vapor Intrusion Building Location
Figure 5.4.7-2	Building 923 Sample Locations
Figure 5.4.7-3	Building 923 Conceptual Site Model
Figure 5.4.8-1	Building 935 Vapor Intrusion Building Location
Figure 5.4.8-2	Building 935 Sample Locations
Figure 5.5.1-1	Building 800 Vapor Intrusion Building Location
Figure 5.5.1-2	Building 800 Sample Locations
Figure 5.5.2-1	Building 887 Vapor Intrusion Building Location
Figure 5.5.2-2	Building 887 Sample Locations
Figure 5.5.3-1	Building 954 Vapor Intrusion Building Location
Figure 5.5.3-2	Building 954 Sample Locations
Figure 5.5.4-1	Building 1038 Vapor Intrusion Building Location
Figure 5.5.4-2	Building 1038 Sample Locations
Figure 5.5.5-1	Building 1131 Vapor Intrusion Building Location
Figure 5.5.5-2	Building 1131 Sample Locations
Figure 5.5.6-1	Building 100 Vapor Intrusion Building Location
Figure 5.5.6-2	Building 100 Sample Locations
Figure 5.5.7-1	Building 564 Vapor Intrusion Building Location
Figure 5.5.7-2	Building 564 Sample Locations
Figure 5.5.7-3	Building 564 Conceptual Site Model
Figure 5.5.8-1	Building 881 Vapor Intrusion Building Location
Figure 5.5.8-2	Building 881 Sample Locations
Figure 5.5.9-1	Building 1037 Vapor Intrusion Building Location
Figure 5.5.9-2	Building 1037 Sample Locations
Figure 5.5.10-1	Building 1042 Vapor Intrusion Building Location
Figure 5.5.10-2	Building 1042 Sample Locations
Figure 5.6.9-1	Building 49 Vapor Intrusion Building Location
Figure 5.6.9-2	Building 49 Sample Locations
Figure 6-1	Facility Overview of Direct Contact Geographical Zones
Figure 6-2	Conceptual Site Model for Soil Exposure Pathways at the Dow Midland Facility
Figure 6-3	Dow Midland Facility Direct Contact Category Flowchart
Figure 6-4	Example Incremental Collection Plot
Figure 6-5	Overview of Zone 1
Figure 6-6	Greenbelt Prior to 2000 Decision Units
Figure 6-7	Greenbelt 2000 to Present Decision Unit 1 of 2
Figure 6-8	Greenbelt 2000 to Present Decision Unit 2 of 2
Figure 6-9	Campus Area Sampled DUs
Figure 6-10	Zone 1 Sampled Decision Units
Figure 6-11	Zone 1 2016 FAST Dioxins and Furans TEQ Results
Figure 6-12	Zone 1 Additional Design Sampling/Decision Units
Figure 6-13	Additional Zone 1 DUs Sampled in 2018
Figure 6-14	Addition Zone 1 DUs Sampled in 2018 Dioxins/Furan FAST Results
Figure 6-15	Direct Contact Zone 2 Decision Units
Figure 6-16	Zone 2 Initial FAST Dioxin and Furan Results for 499 Area
Figure 6-17	Eastern Zone 2 Decision Units Outside of 499 IM Area with Dioxin/Furan TEQ FAST Results Greater than 990 ppt
Figure 6-18	Western Zone 2 Decision Units – 2018 FAST Results
Figure 6-19	Zone 2 499 Area Depth-Discrete Dioxin/Furan FAST Results
Figure 6-20	Zone 2 Railroad Category 1 Decision Units Dioxins and Furans FAST Results
Figure 6-21	Western Zone 2 Decision Units Sampled in 2019
Figure 6-22	Western Zone 2 Decision Units Sampled in 2019 – Dioxins and Furans TEQ FAST Results
Figure 6-23	Zone 3 Sampling Plan

Figure 6-24	Zone 3 Arsenic Exceedances
Figure 6-25	Zone 3 Dioxins and Furans TEQ FAST Results
Figure 6-26	Zone 1 Dioxins and Furans Confirmation Sampling Decision Units
Figure 6-27	Zone 2 Dioxins and Furans Confirmation Sampling Decision Units
Figure 6-28	Midland FAST versus 1613b Dioxins and Furans TEQ Results for Zone 1
Figure 6-29	Midland FAST versus 1613b Dioxins and Furans TEQ Results for Zone 2
Figure 6-30	Decision Units with Dioxins and Furans TEQ Results Between 550-990 ppt
Figure 6-31	Fall 2019 Decision Units – Arsenic Confirmation Sampling
Figure 6-32	Direct Contact Zone 4
Figure 6-33	Direct Contact Zone 4 Category and Decision Unit Figure
Figure 6-34	Direct Contact Zone 4 Confirmation DUs
Figure 6-35	Zone 4 Dioxins and Furans TEQ FAST Results
Figure 6-36	Replicate Sampling Flow Chart for Dioxins and Furans
Figure 6-37	Zone 3 Direct Contact Confirmation DUs
Figure 6-38	Midland FAST versus 1613b Dioxins and Furans TEQ Results for Zone 3
Figure 6-39	Midland FAST versus 1613b Dioxins and Furans TEQ Results for Zone 4
Figure 6-40	Zone 1 UCL Adjusted Dioxins and Furans TEQ Results
Figure 6-41	Zone 2 UCL Adjusted Dioxins and Furans TEQ Results
Figure 6-42	Zone 3 UCL Adjusted Dioxins and Furans TEQ Results
Figure 6-43	Zone 4 UCL Adjusted Dioxins and Furans TEQ Results
Figure 6-44	Division of Zone 3 DU 5C2 for Fall 2019 Direct Contact Sampling
Figure 6-45	Direct Contact Stormwater Basin Areas Sampled in 2019
Figure 6-46	Decision Unit: Z3_5KK_N
Figure 6-47	Decision Unit: Z3_5KK_S
Figure 6-48	Category 5 Stormwater Basins Exceeding Non-Residential DCC - Sitewide
Figure 6-49	Status of Interim Measures and Long-Term Barriers – Zone 1
Figure 6-50	Summary of 2016 Interim Measure Exposure Controls in Pallet Yard Area
Figure 6-51	Status of Interim Measures and Long-Term Barriers – Eastern Zone 2
Figure 6-52	Status of Interim Measures and Long-Term Barriers – Western Zone 2
Figure 6-53	Status of Interim Measures and Long-Term Barriers – Western Zone 3
Figure 6-54	Status of Interim Measures and Long-Term Barriers – Eastern Zone 3
Figure 6-55	Division of Zone 3 Decision Units 1O1 and 1Q2 Direct Contact Fall 2019 Sampling Event
Figure 6-56	Status of Interim Measures and Long-Term Barriers – Zone 4
Figure 6-57	Direct Contact Proposed Zone 5 – Tittabawassee Floodplain
Figure 6-58	Category 4 Decision Units to Sample in 2020
Figure 6-59	Category 6 2020 Confirmation Sampling
Figure 6-60	2019 Follow-Up Confirmation Sampling
Figure 8-1	Monitoring Wells and Piezometers
Figure 8-2	SDF Boring Locations
Figure 8-3	SDF Geologic Conceptual Site Model (CSM) and Hydraulic Conductivity (K) Layers
Figure 8-4	SIM1: Pilot Drain Capture Zone Analysis & Radius of Influence (ROI)
Figure 8-5	Water Balance Steady State Model (leakage from landfill)
Figure 8-6	SDF Modeled Pilot Drain Drawdown
Figure 8-7	Tittabawassee River Stage vs Precipitation
Figure 8-8	Time vs Drawdown 9497
Figure 8-9	SDF January 2019 Contours
Figure 8-10	SDF May 2019 Contours
Figure 8-11	Modeled Slurry Wall and Drain Installation Cell 1
Figure 8-12	SDF Conceptual Proposed Tile & Slurry Wall
Figure 8-13	Cell 1 External Well 3916
Figure 8-14	Cell 1 External Well 3775
Figure 9-1	Site Location Plan – Poseyville Landfill
Figure 9-2	Overview Poseyville Landfill

Figure 9-3	Benzene Plume – 1997 & 2015 – Poseyville Landfill
Figure 9-4	PLF MiHPT Breach in Slurry wall Analysis
Figure 9-5	Poseyville Landfill Plume Optimization Pilot 2019 Plume Characteristics and Pumping Rates – Benzene
Figure 9-6	Poseyville Landfill Plume Optimization Pilot 2019 Plume Characteristics and Pumping Rates – Chlorobenzene
Figure 9-7	Poseyville Landfill Plume Optimization Pilot 2019 Plume Characteristics and Pumping Rates – Ethylbenzene
Figure 9-8	Groundwater Elevation Maps Poseyville Purge Well Optimization Pilot
Figure 9-9	Poseyville Landfill Overall Site Plan
Figure 9-10	Poseyville Landfill Leachate Collection System Improvements Plan and Profile Supplementary Tile
Figure 9-11	Poseyville Landfill Plan and Profile Station 0+00 (POB) Through Station 35+60
Figure 9-12	Poseyville Landfill East Upper Tile Addition
Figure 10-1	Northeast Perimeter Monitoring Well Plan
Figure 10-2	NEP Soil boring & Monitoring Well Data
Figure 10-3	MiHPT Locations NEP Investigation
Figure 10-4	NEP Investigation
Figure 10-5	CFC-11 (Trichlorofluoromethane)
Figure 10-6	6178 Area Conceptual Site Model
Figure 10-7	6175 Area Conceptual Site Model
Figure 10-8	CFC Area Conceptual Site Model
Figure 11-1	CD-3 Area Site Map
Figure 11-2	Contour Map of Shallow Water Table January 2016
Figure 11-3	CD-3 Area 2016 Shallow GW Over GSI Criteria
Figure 11-4	CD-3 Area 2018 Shallow GW Over GSI Criteria
Figure 11-5	CD-3 Area GSI Monitoring Locations
Figure 12-1	The Seventh Street Purge Well Area Site Map (Facility View)
Figure 12-2	The Seventh Street Purge Well Area Site Map
Figure 12-3	Seventh Street Purge Wells Shallow Wells
Figure 12-4	Seventh Street Purge Wells Approximate Extent of Free Product Area
Figure 12-5	Seventh Street Purge Well Area 2013 Soil Removal Area
Figure 12-6	7 th Street Cross Section A-A'
Figure 12-7	7 th Street Cross Section B-B'
Figure 12-8	7 th Street Cross Section C-C'
Figure 12-9	7 th Street Cross Section D-D'
Figure 12-10	7 th Street Bridge Design Near MW-18
Figure 12-11	7 th Street Groundwater Elevation vs. River Elevation
Figure 12-12	7 th Street New Wells Overview
Figure 13-1	Mark Putnam AOC Topographic Map
Figure 13-2	Mark Putnam AOC Soil Boring Location Map
Figure 13-3	Mark Putnam AOC Groundwater Flow Direction
Figure 13-4	Mark Putnam AOC Direct Contact Decision Unit
Figure 14-1	AP Corrective Action Wells Ash Pond Area
Figure 15-1	B-Sewer MH B108 AOC Vicinity Map
Figure 15-2	B-Sewer Manholes
Figure 15-3	B-Sewer MH B108 AOC 2018 Investigation
Figure 15-4	B-Sewer Pilot Study Monitoring Wells
Figure 15-5	B-Sewer Pilot Study Injection Locations
Figure 15-6	Detected VOCs in 9428 DNAPL Samples (Concentrations > 50,000,000 µg/L)

Figure 15-7	Detected VOCs in 9428 DNAPL Samples (Concentration = 1,000,000 µg/L < x < 50,000,000 µg/L)
Figure 15-8	Detected SVOCs in 9428 DNAPL Samples (Concentration > 100,000,000 µg/L)
Figure 15-9	Detected SVOCs in 9428 DNAPL Samples (Concentrations = 30,000,000 µg/L < x < 100,000,000 µg/L)
Figure 15-10	Detected SVOCs in 9428 DNAPL Samples (Concentrations – 1,300,000 µg/L < x < 30,000,000 µg/L)
Figure 15-11	Detected SVOCs in 9428 DNAPL Samples (Concentrations = 270,000 µg/L < x , 1,300,000 µg/L)
Figure 15-12	Detected SVOCs in 9428 DNAPL Samples (Concentrations < 270,000 µg/L)
Figure 15-13	2,3,7,8-TCDD Concentrations and 2,3,7,8-TCDD TEC Values in 9428 DNAPL Samples
Figure 15-14	9428 DNAPL Samples – Viscosity versus Temperature (Pilot Test Summary)
Figure 15-15	Total VOCs of Interest in Groundwater – B-Sewer MH B108 AOC Pilot Study
Figure 15-16	Total SVOCs of Interest in Groundwater – B-Sewer MH B108 AOC Pilot Study
Figure 15-17	Estimated Permanganate Concentrations in Groundwater – B-Sewer MH B108 AOC ISGS Pilot Study
Figure 15-18	B-Sewer Pilot Study – Hydraulic Conductivity Slug Test Results Summary
Figure 15-19	Location of Transect Used for Mass Flux Evaluation – B-Sewer MH B108 AOC ISGS Pilot Study
Figure 15-20	Groundwater Elevations – Baseline Sampling Event – B-Sewer MH B108 AOC ISGS Pilot Study
Figure 15-21	Groundwater Elevations – PM#1 (May 2019) – B-Sewer MH B108 AOC ISGS Pilot Study
Figure 15-22	Groundwater Elevations – PM#4 (November 2019) – B-Sewer MH B108 AOC ISGS Pilot Study
Figure 15-23	Contoured Hydraulic Conductivity – Baseline Sampling Event – B-Sewer MH B108 AOC ISGS Pilot Study
Figure 15-24	Contoured Hydraulic Conductivity – PM#1 (May 2019) – B-Sewer MH B108 AOC ISGS Pilot Study
Figure 15-25	Contoured Hydraulic Conductivity – PM#4 (November 2019) – B-Sewer MH B108 AOC ISGS Pilot Study
Figure 15-26	Total VOC Contours Baseline (March 2019) – B-Sewer MH B108 AOC ISGS Pilot Study
Figure 15-27	Total VOC Contour PM#1 (May 2019) – B-Sewer MH B108 AOC ISGS Pilot Study
Figure 15-28	Total VOC Contours PM#4 (November 2019) – B-Sewer MH B108 AOC ISGS Pilot Study
Figure 15-29	Total VOC Mass Flux Evaluation – B-Sewer MH B108 AOC ISGS Pilot Study
Figure 15-30	Mass Flux Evaluation through Assumed Transect – Total VOCs
Figure 15-31	Total VOC COIs and SVOC COIs in MH B108 – ISGS Pilot Study
Figure 15-32	Hexachlorobenzene – PMP (1613b) and Pilot Study Data (8270)
Figure 15-33	Pentachlorobenzene – PMP (1613b) and Pilot Study (8270)
Figure 15-34	2,3,7,8-TCDD Concentrations at MH B108 PMP and ISGS Pilot Study Data
Figure 15-35	2,3,7,8-TCDD TEC Values at MH B108 – PMP and ISGS Pilot Study Data
Figure 15-36	Observed Estimated Permanganate Concentration vs. Time at MH B108 (ISGS Pilot Study Summary 2019)
Figure 16-1	Overlook Park/Brine Well 13S Overview
Figure 16-2	H-1 Till Sand West of Tertiary Pond Contour Map of Potentiometric Surface Data Collected June 14, 2004
Figure 16-3	H-1 Till Sand West of Tertiary Pond Contour Map of Potentiometric Surface Data Collected June 29, 2004
Figure 16-4	H-1 Till Sand West of Tertiary Pond Contour Map of Potentiometric Surface Data Collected July 12, 2004
Figure 16-5	H-1 Till Sand West of Tertiary Pond Contour Map of Potentiometric Surface Data Collected August 18, 2004
Figure 16-6	1Q 2012 Groundwater Flow Map Brine Site 13S, GIII-27, Midland County, Michigan

Figure 16-7	3Q 2012 Groundwater Flow Map Brine Site 13S, GIII-27, Midland County, Michigan
Figure 16-8	4Q 2012 Groundwater Flow Map Brine Site 13S, GIII-27, Midland County, Michigan
Figure 16-9	Chloride Concentrations Brine Site 13S, GIII-27, Midland County, Michigan
Figure 16-10	Southern Well Chloride Concentrations Brine Site 13S, GIII-27, Midland County, Michigan
Figure 16-11	3Q 2013 Groundwater Flow Map Brine Site 13S, GIII-27, Midland County, Michigan
Figure 16-12	1Q 2015 Groundwater Flow Map Brine Site 13S, GIII-27, Midland County, Michigan
Figure 16-13	Chloride Concentrations in 6158 Cluster
Figure 16-14	6158A Density
Figure 16-15	6158B Density
Figure 16-16	6158C Density

List of Acronyms

ΔP	differential pressure
%	percent
$\mu\text{g}/\text{kg}$	microgram per kilogram
$\mu\text{g}/\text{L}$	microgram per Liter
$\mu\text{g}/\text{m}^3$	microgram per cubic meter
<	less than
>	greater than
\geq	greater than or equal to
2Q 2016	2 nd Quarter 2016
4Q 2016	4th Quarter 2016
α or AF	attenuation factor
AAC	acceptable air concentration
AC	air conditioning
AOC	area of concern
AEHS	Environmental Health and Sciences Foundation
AOI	analyte of interest
ARM	absolute residual mean
ASTM	ASTM International
BEA	Baseline Environmental Assessment
bgs	below ground surface
CaCO_3	calcium carbonate
CA	Corrective Action
CAIP	Corrective Action Implementation Summary Report and Work Plan
CFC	chlorofluorocarbon
CFR	Code of Federal Regulations
cm/sec	centimeter per second
CMI	Corrective Measures Implementation
COC	constituent of concern
COI	constituent of interest
CR	Closure Report
CRREL	Cold Regions Research and Engineering Laboratory
CSM	conceptual site model
CV	coefficient of variation
DC	direct contact
DCA	dichloroethane
DCB	dichlorobenzene
DCC	direct contact criteria
DCE	dichloroethene
DCP	dichloropropane
DEQ	Department of Environmental Quality
DNAPL	dense non-aqueous phase liquid
DOS	Dow On-Site

DU	decision unit
EI	Environmental Indicator
EAC	Environmental Analytical Chemistry
EarthCon	EarthCon Consultants, Inc.
EBS	Expedited Building Summary
ECD	electron capture detector
EDB	1,2-dibromoethane
EDC	1,2-dichloroethane
EGLE	Michigan Department of Environment, Great Lakes, and Energy
EPA	U.S. Environmental Protection Agency
ERDC	Engineer Research and Development Center
EVO	Environmental Operations
EVS	Enterprise Venture Corporation
FID	flame ionization detector
ft	foot, feet
ft ²	square feet
ft/ft	feet per foot
ft/day	feet per day
GC	gas chromatography
GCL	geosynthetic clay liner
GIS	geographic information system
gpm	gallons per minute
GPS	global positioning system
GSI	groundwater-surface water interface
HCBD	hexachlorobutadiene
HDPE	high-density polyethylene
HPT	hydraulic profiling tool
HSWA	hazardous and solid waste amendment
HVAC	heating, ventilation, and air conditioning
IA	indoor air
ID	Identification
IET	Innovative Environmental Technologies, Inc.
IH	Industrial Hygiene
IM	interim measure
IRA	Interim Response Action
ISGS	in-situ (bio)geochemical stabilization
ISM	incremental sampling methodology
ITRC	Interstate Technology and Regulatory Council
kg	kilogram
LEL	lower explosive limit
LTM	long-term monitoring
m ²	square meter
MCL	maximum contaminant level
MDEQ	Michigan Department of Environmental Quality
MDNR	Michigan Department of Natural Resources

MEK	methyl-ethyl ketone
mg/kg	milligram per kilogram
mg/L	milligram per liter
MH	manhole
MIBK	methyl isobutyl ketone
MiHPT	membrane hydraulic profiling tool
MiOps	Michigan Operations
MIOSHA	Michigan Occupational Safety and Health Administration
mL	milliliter
mm	millimeter
MnO ₄ ⁻	permanganate
MRO	Maintenance/Repair/Operations
NA	not applicable
NAPL	non-aqueous phase liquid
NAVD	North American Vertical Datum
NAVFAC	Naval Facilities Engineering Command
NC	not calculated
ND	non-detect
NEP	Northeast Perimeter
NFA	No Further Action
nm	nanometer
NOAA	National Oceanic & Atmospheric Administration
NPDES	National Pollutant Discharge Elimination System
NREPA	Natural Resources and Environmental Protection Act
NRMS	normalized root mean square
OA	outdoor air
OEL	occupational exposure limit
O&M	operation and maintenance
OSHA	Occupational Safety & Health Administration
PAH	polynuclear aromatic hydrocarbon
PCB	polychlorinated biphenyl
PCE	tetrachloroethene
PCOI	potential contaminant of interest
PFOA	perfluorooctanoic acid
PFOS	perfluorooctane sulfonic acid
pg/L	picogram per liter
PID	photoionization detector
PLF	Poseyville Landfill
PMP	Pollution Minimization Program
ppbv	parts per billion by volume
PPE	personal protective equipment
ppm	parts per million
ppmv	parts per million by volume
ppt	parts per thousand
Provectus	Provectus Environmental Products

psi	pounds per square inch
psig	psi gauge
PVC	polyvinyl chloride
RAP	Remedial Action Plan
RCRA	Resource Conservation and Recovery Act
R&D	Research & Development
RGIS	Revetment Groundwater Interception System
RFI	RCRA Facility Investigation
RIASL	Recommended Interim Action Screening Levels
RL	reporting limit
ROI	radius of influence
RPD	relative percent difference
RSL	regional screening level
SAP	Sampling and Analysis Plan
SDF	Sludge Dewatering Facility
SL	screening level
SSSG	sub-slab soil gas
S.U.	standard unit
SVOC	semivolatile organic compound
SWL	static water level
SWMU	solid waste management unit
TAL	target analyte list
TBD	To Be Determined
TCA	trichloroethane
TCB	trichlorobenzene
TCDD	tetrachlorodibenzo-p-dioxin
TCE	trichloroethene
TEC	toxic equivalent concentration
TEQ	toxic equivalent
TMB	trimethylbenzene
TOC	top of casing
TSRIASL	Time-Sensitive Recommended Interim Action Screening Levels
USGS	United States Geological Survey
UV	ultra violet
VI	vapor intrusion
VSIC	Volatile Soil Inhalation Criteria
VOC	volatile organic compound
WMU	waste management unit
WWTP	Wastewater Treatment Plant
XSD	halogen-specific detector

EXECUTIVE SUMMARY

This 2019 Annual Corrective Action Implementation Summary Report and 2020 Work Plan (CAIP) is being submitted to summarize the Corrective Action activities that were completed in 2019 and those activities that are planned for 2020, in accordance with the Condition XI.R of the Operating License issued September 25, 2015.

The current operating license period spans from 2015-2025. At the beginning of the license period, Dow proposed corrective action goals that remained relatively unchanged through the initial years. After five years and substantial changes in policy, regulation, approach and understanding, Dow and EGLE have agreed that Dow should revisit these goals to reassess status, make adjustments, and establish measurable milestones to achieve a positive determination that the HE EI has been met for the Soil Direct Contact, Indoor Air and On-site Outdoor Air pathways.

The current phase of corrective action work at the Midland Facility prioritizes achieving the HE EI met determination. Measurable milestones for this goal are necessary to ensure that once the appropriate milestones have been achieved, there will be concurrence that the HE EI can be considered “under control.” A positive HE EI determination indicates that there are no “unacceptable” human exposures to “contamination” (i.e., contaminants in concentrations in excess of appropriate risk-based levels) that can be reasonably expected under current land- and groundwater-use conditions (for all “contamination” subject to RCRA Corrective Action at or from the identified facility [i.e., site-wide]).

The 2020 updated primary goals for the License period, defined and discussed in more detail in the subsequent sections, are as follows:

- Maintain “under control” for the Migration of Contaminated Groundwater EI
- Reach “under control” status for the HE EI for the Direct Contact (DC) to Soil Pathway at the Midland Plant.
- Reach “under control” status for the HE EI for the On-Site Outdoor Air Pathway at the Midland Plant.
- Reach “under control” status for the HE EI for priority buildings (Category 1 and Category 2 buildings) within the Midland Plant for Vapor Intrusion (VI)
- Develop plan for HE EI VI assessment of Category 3/Deferred Buildings
- Define and initiate management strategies as required at AOCs located along the Midland Plant perimeter not contained by the Revetment Groundwater Interception System (RGIS)
- Implement additional Source Control measures where mobile free phase liquids are identified, with priority given to those areas with potential to impact human health and the environment beyond the source area.

In order to achieve these goals, Dow has prioritized corrective action activities, implemented planning, and sampling and remedies in 2019, and has identified the next activities as described in this 2019 Summary Report and Work Plan for 2020.

Sections 1.0 through 3.0 provide introduction and background information regarding the goals and objectives of the license period and a high-level summary of source control measures on site. The specific sections of the Work Plan listed below will describe the 2019 priority corrective actions implemented and/or the work planned for 2020:

- Section 4.0 Revetment Groundwater Interception System

- Section 5.0 Midland Plant Facility-Wide Vapor Intrusion Pathway
- Section 6.0 Midland Plant Facility-Wide Direct Contact to Soil Pathway
- Section 7.0 On-Site Outdoor Air Pathway
- Section 8.0 Sludge Dewatering Facility
- Section 9.0 Poseyville Landfill
- Section 10.0 Northeast Perimeter
- Section 11.0 Chemical Disposal Well 3
- Section 12.0 7th Street Purge Wells Area (Fuel Oil Tank Farm)
- Section 13.0 Mark Putnam Road AOC
- Section 14.0 Former Ash Pond AOC
- Section 15.0 B-Sewer Manhole B108 Area AOC
- Section 16.0 Overlook Park and 13s

Investigation activities at PLF, and Sludge Dewatering Facility (SDF) completed during 2019 support the long-term site goal to maintain the EI status of “under control” for the migration of contaminated groundwater. The corrective actions for both the Direct Contact (DC) to Soil, Vapor Intrusion (VI), and On-Site Outdoor Air Pathways continue to work towards achieving an “under control” status for the Human Exposure EI.

Remediation plans developed for and implemented at the former Ash Pond AOC, 7th Street Purge Wells, Mark Putnam Road AOC, and Northeast Perimeter (NEP) support the goal to define and implement remedy for AOCs at the Midland Plant perimeter. Continued operation of existing recovery systems and the finalization of the field-scale pilot study at the B-Sewer Manhole B108 AOC will occur in 2020 to maintain source control measures where mobile free phase liquids are identified.

1.0 INTRODUCTION

Licensed hazardous waste management facilities are required to conduct corrective action as necessary to protect the public health, safety, welfare, and the environment for all releases of a contaminant from any waste management units (WMUs) at a facility, pursuant to Part 111. The purpose of the Part 111 Corrective Action Program is to address releases of hazardous wastes and hazardous constituents at hazardous waste management facilities in a timely manner. Corrective actions conducted pursuant to Part 111 are designed to be protective of human health and the environment both in the short-term and long-term. Short-term corrective action focuses on the implementation of interim actions to achieve stabilization and to control the source(s) of release to reduce or eliminate, to the extent practicable, further releases of hazardous waste or hazardous constituents that may pose a threat to human health or the environment. To be protective in the long-term, final remedies are designed and implemented to achieve media specific cleanup objectives, either through remediation and/or institutional controls, including identification of specific points of compliance and monitoring.

For the purposes of Part 111, corrective action applies to areas or units described as WMUs or areas of concern (AOCs). WMUs are defined as any discernible unit at which solid wastes have been placed at any time, irrespective of whether the unit was intended for the management of solid or hazardous waste. Such units include any area at the Midland Plant at which solid wastes have been routinely and systematically released. AOCs are areas where hazardous waste, hazardous constituents, or hazardous substances may have been released to the environment on a non-routine basis, which may present an unacceptable risk to public health, safety, welfare, or the environment, and are subject to the corrective action requirements of Part 111 of Act 451 and the remediation requirements of Part 201 of Act 451.

The Michigan Operations Midland Plant is a large industrial site located in Midland, Michigan with an operating history of over 115 years and multiple historical sources of contamination. The site location is identified in Figure 1-1. The entire Midland Plant is designated as a WMU and within the Midland Plant; there are a number of individual WMUs and AOCs. The locations of the WMUs and AOCs at the Midland Plant are shown in Figures 1-2 and 1-3, respectively. A summary of each unit/area is provided on the 2019 update of Table B2-1 of the License - *Summary of Actual or Potential Sources of Contamination* (Table 1-1)¹.

At the Midland Plant, corrective action is performed in a phased approach that focuses on areas that represent the greatest short-term risk to human health and/or the environment, which is consistent with site corrective action objectives.

Corrective action at the Midland Plant focused on five main priorities:

- Site-Wide Containment;
- Worker Exposure Control Program;
- Monitored Natural Attenuation;
- Contaminant Mass Reduction; and
- Off-site Corrective Action.

¹ As discussed in the November 2019 CA Status Update Meeting, the 2019 update of Table B2-1 includes an identification number change for the WMUs and AOCs listed in the table. The intent of the renumbering is to ensure that if new areas are added to the table the organization of the table remains intact and that the existing areas are not assigned new numbers moving forward. A cross-walk detailing the new numbers assigned and the corresponding old numbers is included in Table 1-2.

The goals of these activities and programs has been to achieve stabilization of the WMUs, meet the Groundwater Contained Environmental Indicator (EI), manage worker exposure, and address off-site releases. The current phase of corrective action emphasizes meeting the Human Exposure (HE) EI.

This 2019 Annual Corrective Action Implementation Summary Report and 2020 Work Plan (2019/2020 CAIP) is being submitted to summarize the Corrective Action activities completed in 2019 and those that are planned for 2020, in accordance with the Condition XI.R of the Operating License issued September 25, 2015.

As discussed further in Section 2.0, the schedule for the current license period (2015 to 2025) has been updated and is summarized in the updated *Corrective Action Implementation Plan High Level Overview* (Figure 1-4).

2.0 GOALS AND OBJECTIVES FOR LICENSE PERIOD

The current operating license period spans from 2015-2025. At the beginning of the license period, Dow proposed corrective action goals that remained relatively unchanged through the initial years. After five years and substantial changes in policy, regulation, approach and understanding, Dow and EGLE have agreed that Dow should revisit these goals to reassess status, make adjustments, and establish measurable milestones to achieve a positive determination that the HE EI has been met for the Soil Direct Contact, Indoor Air and On-site Outdoor Air pathways.

As detailed in Section 1.0, the current phase of corrective action work at the Midland Facility prioritizes achieving the HE EI met determination. Measurable milestones for this goal are necessary to ensure that once the appropriate milestones have been achieved, there will be concurrence that the HE EI can be considered “under control.” A positive HE EI determination indicates that there are no “unacceptable” human exposures to “contamination” (i.e., contaminants in concentrations in excess of appropriate risk-based levels) that can be reasonably expected under current land- and groundwater-use conditions (for all “contamination” subject to RCRA Corrective Action at or from the identified facility [i.e., site-wide]).

The 2020 updated primary goals for the License period, defined and discussed in more detail in the subsequent sections, are as follows:

- Maintain “under control” for the Migration of Contaminated Groundwater EI
- Reach “under control” status for the HE EI for the Direct Contact (DC) to Soil Pathway at the Midland Plant.
- Reach “under control” status for the HE EI for the On-Site Outdoor Air Pathway at the Midland Plant.
- Reach “under control” status for the HE EI for priority buildings (Category 1 and Category 2 buildings) within the Midland Plant for Vapor Intrusion (VI)
- Develop plan for HE EI VI assessment of Category 3/Deferred Buildings
- Define and initiate management strategies as required at AOCs located along the Midland Plant perimeter not contained by the Revetment Groundwater Interception System (RGIS)
- Implement additional Source Control measures where mobile free phase liquids are identified, with priority given to those areas with potential to impact human health and the environment beyond the source area.

Each of the goals is discussed further below.

2.1 Achieve Control of Human Exposures

As part of the License Reapplication for the current operating license, Dow completed the Resource Conservation and Recovery Act (RCRA) EIs for Human Health for the Midland Facility. Based on the conclusions of the EI, the following exposure pathways warrant further evaluation to achieve “under control” status under the EI:

- Soil Direct Contact (DC)
- Indoor Air
- On-Site Outdoor Air

The conclusions of the EI determination found that soils (surface and subsurface soils) were known to be contaminated above appropriately protective risk-based levels. The EI conclusions indicated that it was unknown whether or not indoor air due to VI was contaminated above appropriately protective risk-based levels. Based on the ongoing ambient air monitoring program, no significant impact has been identified at the facility; however, Dow will continue to evaluate the ambient air pathway (on-site outdoor air) as data is collected for the DC assessment.

In order to reach the HE EI under control status for the Midland Plant, it is necessary to reach this determination for each of the remaining inconclusive pathways independently. Measurable milestones have been developed to establish when HE EI will be considered met for portions of or each of the three remaining pathways. Dow has also developed a high-level conceptual schedule to meet these milestones.

The revised schedule as well as the associated proposed milestones are subject to change due to an adaptive management approach. This approach is employed to use sound science and technology to re-evaluate and prioritize site activities to account for new information and changing site conditions to target management and resource decisions with the goal of reducing site uncertainties and continuing site progress.

The following subsections present further discussion on the soil DC, indoor air, and on-site outdoor air exposure pathways and an overview of how Dow plans to achieve “under control” status for each of these medium.

2.1.1 Soil Direct Contact

Surface soil (< 2 ft deep) contamination is generally present throughout the Facility as a result of historical releases from former combustion units and manufacturing units and largely contains persistent compounds with low solubility that are strongly sorbed to soil particles. Subsurface soil (> 2 ft deep) contamination is generally present throughout the Facility as a result of historical releases from manufacturing or WMUs and may also include volatile organic compounds (VOCs), semivolatile organic compounds (SVOCs), and metals, in addition to the persistent compounds also found in surface soil.

The soil DC pathway includes exposure via long-term dermal contact with and ingestion of soils throughout the soil column, regardless of depth. For potential on-site receptors, this exposure pathway is complete. Aerial dispersion, wind-blown dust, and operations of the facility over time have yielded some detected soil concentrations near or at the surface that are greater than the soil DC non-residential generic criteria. Exposure to soils at depth is not reasonably expected to be significant since the exposure routes are managed by the required use of personal protective equipment (PPE) specified in the Worker Exposure Control Plan (Appendix C of Attachment 19 of the License).

Beginning in 2001, presumptive remedy was performed at the site in the form of surface cover enhancements in areas prioritized for early action to address elevated levels of dioxins and furans in surface soils under the Enhanced Exposure Control Program for Phase I Areas. Areas were prioritized using results from the 1996 and 1998 trace organic analysis of surface soils for dioxins and furans. In addition to the improvements to Phase I Areas, an additional 100 acres of vegetative storm water detention areas have been constructed from 2009 to 2011 which also provided a direct contact (DC) barrier to the existing soils.

While significant work was completed to improve surface cover at the Midland Plant prior to the current license period there was still a large area eligible for assessment to determine if additional surface improvements were warranted. That remaining area of the Midland Plant, including gravel or grassed areas that had not been addressed or assessed prior to the license period have been the focus of the DC evaluation for enhanced surface cover. From 2016-2019 Dow has completed sampling and assessment on an additional 644 acres within the facility boundary.

In order to achieve “under control” status for the HE EI for DC, Dow is evaluating the site in a phased approach, primarily referred to as Zones (Figure 2-1), and will continue to complete surface improvements in the remaining areas of the facility, as necessary. Section 6.0 summarizes the work that was completed prior to 2019, details the work completed in 2019, and presents the work that will be completed in 2020.

As discussed in the November Dow/EGLE Corrective Action status meeting, HE EI will be considered met for the DC pathway when:

- All unpaved areas are assessed in accordance with the approved DC methodology described in Section 6.0
- All areas determined to have dioxins and furans toxic equivalent (TEQ) results above the non-residential direct contact criteria (DCC) (990 parts per thousand [ppt]) have interim measures or long-term remedy employed to limit exposure
- All areas determined to have a concentration of any other hazardous substance above non-residential DCC for soil have interim measures or long-term remedy employed to limit exposure

Dow anticipates that these milestones for the DC pathway can be achieved by 2023 by implementing the following high-level conceptual milestone schedule:

2020

- Complete Zone 5 Tittabawassee Floodplain Sampling
- Complete additional sampling in Category 3 and 4 areas for dioxins and furans

2021

- Conduct verification sampling in Category 3 and 4 areas as necessary
- Assess railyard and electrical substation areas

2022

- Finalize implementation of interim measures and long-term remedies necessary to limit exposure

2023

- HE EI under control for DC Pathway

2.1.2 Indoor Air

Indoor air at the facility is primarily evaluated through the industrial hygiene (IH) program. The IH program evaluates and measures those analytes that are relevant for occupational industrial exposure; however, the specific potential influence of VI on the indoor air is not determined through the IH program. VI can occur from groundwater volatilization to indoor air and soil volatilization to indoor air. Like the DC pathway, in order to achieve “under control” status for the EI, Dow is evaluating VI at the facility in a phased approach including the definition of zones (Figure 2-2). Section 5.0 summarizes the work that was completed prior to 2019, details the work completed in 2019, and presents the work that will be completed in 2020.

The groundwater volatilization to indoor air exposure pathway addresses vapors emanating from groundwater that could move through the soil vadose zone and migrate to indoor air at the Midland Plant

and is only applicable to volatile compounds. The soil volatilization to indoor air exposure pathway addresses vapors that could move through the soil vadose zone and migrate to indoor air in buildings at the facility. This exposure pathway is potentially complete for on-site workers through the inhalation of vapors in indoor air of buildings where they work or routinely visit. On-site worker protection and compliance with Michigan Occupational Safety and Health Administration (MIOSHA) standards is monitored through plant specific IH monitoring programs.

Currently, the facility has approximately 700 buildings and structures on-site. The phased approach for VI uses a building categorization procedure to prioritize worst case buildings for investigation and uses a weight of evidence framework for assessing the VI pathway. The building categorization flowchart is presented on Figure 2-3.

Category 1 and 2 buildings are priority buildings and are being sampled throughout the facility during the initial phased approach. Category 3 buildings are deferred until all priority buildings are sampled and evaluated. Category 4 and 5 buildings are not sampled or included in the VI investigation. Following the *Process for Evaluating VI and Determination of Path Forward Flowchart* on Figure 2-4 all sampled buildings are then placed into groups determined by investigative results.

As discussed in the November Dow/EGLE Corrective Action status meeting, the VI pathway can be broken down by these building categories and groupings to describe how milestones can be met towards achieving “under control” status for the HE EI VI within the license period. While it is not anticipated that the HE EI will be met for this pathway in the current License period, it is the intent that it can be considered met for specific Categories of buildings within the License period as Dow works through the phased approach on the site.

After completion of initial investigations of all Category 1 and Category 2 buildings within the Midland facility boundary and completion of seasonal evaluation and/or building specific investigations of these priority buildings as necessary to finalize the VI path forward grouping classification, the determination that no unacceptable human exposures to contamination from VI can be reasonably expected under current land- and groundwater use conditions will be determined based on the building grouping as such:

- Group 1 and 3 Buildings – HE EI Met once grouping is determined
- Group 2 and 4A Buildings (OELs) – HE EI Met upon initiation of interim monitoring
- Group 4B Buildings – HE EI Met once interim measures are complete

Once all Category 1 and Category 2 buildings within the facility have been assessed, the Category 3/Deferred buildings assessment will be the next priority. Dow will then incorporate the site knowledge gained through the Category 1 and Category 2 building assessment and propose a process to assess this group of buildings.

Dow anticipates that these milestones for the VI pathway, including the HE EI met determination for Category 1 and Category 2 buildings, can be achieved by 2023 by implementing the following high-level conceptual milestone schedule:

2020

- Initiate Z3P3 Priority Building Sampling in Fall

2021

- Initiate Z4 Campus Area Priority Building Sampling in Fall

2022

- Start Z5 West of Tittabawassee River Priority Building in Fall

2023

- Finish Z5 West of Tittabawassee River Priority Building Sampling
- Complete IMs on any 4B Buildings
- HE EI Met for Category 1 and Category 2 Buildings
- Propose Plan for Category 3 Building Assessment

2.1.3 On-Site Outdoor Air

In order to achieve “under control” status for the EI, Dow will maintain current ambient air and fugitive dust monitoring programs. The soil volatilization to ambient air and particulate soil inhalation pathways will be considered as relevant data is collected to support the DC pathway evaluation during this license period.

Once all the areas subject to investigation for the DC pathway have been assessed and results have been confirmed to be less than the EGLE screening values for soil volatilization to ambient air and particulate soil inhalation HE EI will be considered met for this pathway. The schedule for meeting HE EI for this pathway is the same as the DC Pathway.

2.1.4 Soil Volatilization to Ambient Air

The soil volatilization to ambient air exposure pathway applies to all land uses where hazardous substance vapors may emit from soils to ambient air. The outdoor air at the facility is monitored by the Ambient Air Monitoring Program (Attachment 16 of the License). Dow will continue to monitor and review ambient air as part of future corrective action efforts (Appendix G of Attachment 19 of the License).

Construction workers can potentially encounter vapors when working with subsurface soils or in a trench scenario; however, exposure is not reasonably expected to be significant since the exposure routes are managed by the required use of PPE and air monitoring specified in the Worker Exposure Control Plan, Appendix C of Attachment 19 of the License.

2.1.5 Particulate Soil Inhalation

The particulate soil inhalation exposure pathway addresses the emission and dispersion of contaminated soil particles into the ambient air (inhalation of fugitive dust particles). Exhaust constituents from process vents, power generation, and thermal incineration processes may have deposited onto plant soils. During dry periods, these soils may have been disturbed by equipment or vehicles and blown by the wind, resulting in fugitive dust emissions.

Fugitive dust control has been in progress at the Midland Plant since 1986. Dow is currently required by the 2015 Operating License and its Renewable Operating Permit (Section 1, IX.5) to provide and regularly update an operating program to control fugitive dust sources or emissions. The current fugitive dust control program requires semi-annual review and updates. In addition, fugitive dust emissions from the facility are monitored for dioxin emissions on an ongoing basis along the plant perimeter pursuant to the “Soil Box Data Evaluation Plan,” approved by Michigan Department of Environmental Quality (MDEQ) on September 25, 2015. Monitoring began in 2002 and continues to show the fugitive dust control program for the facility is effective.

In order to limit the generation of fugitive dust and particulates, Dow has placed surface cover on surface soil in certain areas of the facility. The covers include clean top soil and vegetation, gravel, and/or asphalt. Existing covers are managed and maintained. Based on current conditions, this pathway is likely to be adequately controlled.

2.2 Sustain Control of Contaminated Groundwater

To maintain the status as “under control” for the Migration of Contaminated Groundwater (GW) EI, corrective action includes activities such as maintaining RGIS and other corrective action systems, completing system upgrades as necessary, monitoring groundwater, investigation and other remedial actions to address increasing trends in contaminants or indicator parameters identified during environmental monitoring. Substantial work was completed in 2019 to maintain the under control status of the GW EI.

A pilot project was conducted within Cell 1 of the closed Sludge Dewatering Facility (SDF) during 2019 to assess the effectiveness of a cell upgrades to increase drainage in the cell. The results of the evaluation and planned continued efforts are discussed in detail in Section 8.0.

Work also continued at Poseyville Landfill (PLF) to enhance containment of contaminated groundwater. In 2019, the leachate collection tile system upgrade in the southern portion of the landfill that was initiated in 2018 was completed. Additionally, 3600 ft of tile was replaced on the northern perimeter of the landfill and approximately 475 ft of slurry wall was completed to cut off the potential source of the plume area located in the north east corner of the landfill. The Purge Well Pilot Optimization study also continued at PLF in 2019 to better manage the plume in the northeast corner of the landfill. Greater detail regarding work at PLF is provided in Section 9.0.

At locations where engineering controls are not in place, such as Northeast Perimeter (NEP) and Chemical Disposal Well 3, additional corrective actions were also taken during 2019 to better understand and manage these sites. These efforts are and next steps for these areas are found detailed in Sections 10.0 and 11.0, respectively.

Based on age, design, and current operating conditions, a project to upgrade the RGIS from Lift Station #4 to Lift Station #5 is planned for future construction and discussed in Section 4.0.

2.3 Remedy Implementation for AOCs

By 2025, Dow intends to define and initiate management strategies as required at AOCs located along the Midland Plant perimeter not contained by the RGIS including, the Former Ash Pond; Overlook Park/Brine Well 13S; Chemical Disposal Well 3; 7th Street Purge Wells (Former Fuel Oil Tank Farm); Pure Oil; US-10 Tank Farm; Mark Putnam AOC; and Brine Spill Sites 4M, 32S and 6 Pond Purge Wells. Background information on each of these AOCs can be found in the 2016 Corrective Action Implementation Work Plan (12/30/2015).

During 2019, corrective actions were conducted at the following sites:

- Chemical Disposal Well 3 (Section 11.0);
- 7th Street Purge Wells (Section 12.0);
- Mark Putnam AOC (Section 13.0); and
- Former Ash Pond (Section 14.0).

Continued work at these AOCs in 2020 is detailed in each respective section. The remaining AOCs will be addressed according to the updated Corrective Action Implementation Plan High Level Overview (Figure 1-4).

2.4 Additional Source Control Measures for Mobile Free Phase Liquids

Dow has identified 17 areas of free product, consistent with the Compliance Schedule H-8 of the 2003 Operating License. In 2014, Dow installed a free-product recovery system in lower explosive limit (LEL) III. Since installation, approximately 34,375 gallons of free product were recovered through the end of December 2019. Manual recovery operations conducted at additional wells recovered approximately 12 gallons of dense non-aqueous phase liquid (DNAPL) in 2019.

Significant efforts were completed at B-Sewer Manhole (MH) B108 AOC and at 1925 Landfill in 2019 to achieve additional source control. At B-Sewer Manhole (MH) B108 AOC work was focused on stabilizing the non-aqueous phase liquid (NAPL)-impacted area (Section 15.0). The goal of the work at 1925 Landfill was to obtain a high-resolution site characterization of the subsurface conditions with the objectives to not only further refine the existing Conceptual Site Model (CSM), but also to identify DNAPL zones, microbially active zones, and interconnected flow zones (Section 3.1).

During 2020, work will consist of on-going operation of the manual recovery and free product recovery system installed in LEL III. Additionally, in 2020 work will continue at the B-Sewer Manhole (MH) B108 AOC to assess the NAPL-impacted area as further described in Section 15.0.

2.5 2019 Releases to Soil

In September 2019, EGLE requested that Dow include information regarding any occurrence of sewer overflow events within the facility in the annual CAIP. This topic was then added to the Dow/EGLE Corrective Action monthly coordination meeting for September and it was agreed that the overflows would be documented on the annual update of the B2-1 Table submitted with the CAIP (Table 1-1). It was then subsequently clarified during the November Corrective Action monthly coordination meeting that a new table, created solely for the sewer releases, would have to be created and would be referenced in the B2-1 Table in the F41 AOC (the Wastewater Treatment Plant) line item. The new table created to document the sewer releases within the facility is Table B2-4; it will be updated annually. It is included in this CAIP as Table 2-1.

In 2019, there were four overflow events which occurred in March, August and September of 2019 in the same general location. Information regarding each one of these releases a summary of the release, an assessment of actual or potential hazard, immediate actions taken, and the status of the area are included on Table 2-1. A map showing the locations of the overflow areas is provided as Figure 2-5.

2.6 Priority Actions Completed in 2019

Dow completed the following priority activities during 2019:

VI Pathway

- Further defined areas of the facility for the phased approach
- Conducted building occupancy assessments for all buildings previously sampled
- Created a sampling plan for each priority building to be sampled in Zone 3 Phase 2

- Submitted Expedited Building Summaries for 3 buildings and provided email updates for all buildings that required notification
- Conducted soil-gas, indoor air and outdoor air sampling at the Category 1 and 2 buildings within Zone 3 Phase 2
- Conducted seasonal confirmation sampling for VI Path Forward Group 2 and 4 buildings in Zones 1, 2 and 3
- Conducted Further Investigation activities at 14 buildings with a mobile gas chromatography (GC) to determine the source(s) of indoor air exceedances and submitted Summary of Investigative Findings documenting each event
- Completed seasonal confirmation sampling, implemented interim monitoring at 13 buildings and proposed interim monitoring plans for an additional 7 buildings in the CAIP
- Continued interim action plans and implemented interim measures at Buildings 680 and 941

DC to Soil Pathway

- Performed interim measures/installed long-term barriers in DC Zones 2 and 3 to address elevated concentrations of dioxins and furans;
- Conducted soil sampling of identified decision units (DUs) in Zone 4
- Conducted soil sampling at additional stormwater features across the site to update the Direct Contact Conceptual Site Model for the Midland facility
- Conducted replicate sampling in Zones 3 and 4 for specific DUs to assess the precision and accuracy of incremental sampling methodology (ISM) and laboratory processes/analyses used and to confirm 2018 results for specific Zone 3 DUs with U.S. Environmental Protection Agency (EPA) Method 1613b
- Evaluated results and identified a path forward based on the results

On-site Outdoor Air Pathway

- Completed Soil Volatilization to Ambient Air evaluation for DC Zone 4
- Completed Particulate Soil Inhalation evaluation for DC Zone 4

SDF

- Installed eight monitoring wells to assess the Cell 1 pilot drain installation
- Collected performance data on the system with In Situ® Level Troll 700 pressure transducers from January 11, 2019 to July 1, 2019
- Assessed demonstration data to evaluate the pilot system
- Modeled changes to full scale implementation design and developed conceptual plan

Poseyville Landfill

- Conducted plume analytics to help provide a better understanding and delineation of the northeast plume
- Modified pump rates in response to observed environmental conditions and completion of slurry wall
- Continued additional monitoring of wells 2549, 5924, and 5923 to support plume modeling
- Continued well monitoring program to ensure proper well conditions in 2690A and 2917
- Analyzed pump and chemical data to assist in optimization 2690A and 2917
- Completed southern perimeter tile replacement
- Submitted Hydraulic Report and Design package for the north tile replacement and slurry wall
- Installed 3600 ft of replacement tile along the northern perimeter of the landfill
- Completed 475 ft of slurry wall to eliminate sourcing to northeast plume

Northeast Perimeter

- Completed preliminary remedial technology screenings for 6175, 6178, and CFC areas
- Developed a preliminary workplan for data gap analysis

CD3

- Evaluated site data to develop short term monitoring plan for groundwater sampling and static water level data collection
- Initiated monitoring plan and conducted 2 bi-monthly events
- Assessed new site data and verified flow direction

7th Street Purge Wells Area (Fuel Oil Tank Farm)

- Completed cross-sections and additional research on the bridge design
- Developed site conceptual site model (CSM) and fieldwork implementation plan
- Installed 2 additional monitoring wells to evaluate groundwater flowing towards MW-18
- Repaired water main leak encountered during well installation
- Developed and began sampling new wells in addition to compliance wells

Mark Putnam AOC

- Developed workplan for investigation of new AOC
- Completed seven soil borings to collect information on lithology, groundwater elevation, and chemical concentrations in soil and groundwater

- Analyzed site data to establish groundwater flow direction, extent of contamination and identified data gaps for further investigation

Former Ash Pond AOC

- Developed high-resolution CSM to better understand site conditions
- Conducted a CSM and Path Forward Meeting with EGLE
- Submitted a CSM technical memo EGLE
- Completed Part I of Remedial Action Plan (RAP)/Corrective Measures Implementation (CMI)
- Developed workplan for seep investigation and data to support CSM

B-Sewer Manhole B108 Area

- Submitted New AOC Notification for MH B108 AOC to EGLE in January 2019
- Implemented field-scale pilot study to demonstrate Provect-GS® is effective in encapsulating DNAPL at the AOC, which included sampling of soil, groundwater, DNAPL, and the sewer as well as slug testing;
- Commenced evaluating results of pilot study to determine efficacy of the Provect-GS® remedial technology at MH B108 AOC and for possible future applications at other AOCs or WMUs

Overlook Park and 13S

- Submitted long-term compliance monitoring program with SAP Revision 8A
- Examined existing site data to confirm validity of site CSM

The following sections will describe the work conducted in 2019 and planned 2020 priority corrective actions that will be implemented:

- Section 3.0 Source Control Measures
- Section 4.0 RGIS
- Section 5.0 Midland Plant Facility-Wide Vapor Intrusion Pathway
- Section 6.0 Midland Plant Facility-Wide Direct Contact to Soil Pathway
- Section 7.0 On-Site Outdoor Air Pathway
- Section 8.0 Sludge Dewatering Facility
- Section 9.0 Poseyville Landfill
- Section 10.0 Northeast Perimeter
- Section 11.0 Chemical Disposal Well 3
- Section 12.0 7th Street Purge Wells Area (Fuel Oil Tank Farm)

- Section 13.0 Mark Putnam Road AOC
- Section 14.0 Former Ash Pond AOC
- Section 15.0 B-Sewer Manhole B108 Area AOC
- Section 16.0 Overlook Park and 13S
- Section 17.0 2020 Conceptual Schedule
- Section 18.0 References

3.0 SOURCE CONTROL MEASURES

As mentioned in Section 2.4, significant efforts were completed at B-Sewer Manhole (MH) B108 AOC and at 1925 Landfill in 2019 to achieve additional source control.

3.1 1925 Landfill

In 2018, Dow began the development of a high-resolution site characterization of the subsurface conditions in the 1925 Landfill Area with the objectives to not only further refine existing CSM, but also to identify DNAPL zones, microbially active zones, and interconnected flow zones. In October 2018, Aestus, LLC was contracted to perform their GeoTrax CSM+™ development process, integral proprietary electrical resistivity imaging (ERI) scanning technology (GeoTrax Survey™) and data integration and visualization process (GeoTrax Viz™). Evaluation of the preliminary ERI results were done in early 2019 and subsequently the scope of work was developed to perform the necessary field verification (in the form of confirmatory soil borings) of the observed field geophysical responses.

This scope of work includes advancement and logging of soil boring locations within the 1925 Landfill Area and discrete depths prescribed for the collection of soil, groundwater, and microbial samples. The data collected from the field verification activities will be used by Aestus LLC to develop a final calibration of the GeoTrax CSM+™ where then a finalized CSM and Data Interpretations Report will be provided to Dow. This successful demonstration of this high-resolution site characterization application will then be available as a tool to serve as a guide for the evaluation of, and implementation of additional future source control measures were mobile free phase liquids are identified.

3.2 B-Sewer Manhole (MH) B108 AOC

The B-Sewer Manhole (MH) B108 AOC is located along the 10th Street corridor, south of E Street, and west of the pipe rack near 1385 Building. This AOC was identified during a source area investigation completed in 2018. The dense non-aqueous phase liquid (DNAPL)-impacted area and surrounding high analyte concentration area is estimated to be approximately 37,500 square feet in size. Due to the identification of an area with free product with measurable thickness, a new source discovery notification was sent to EGLE on January 10, 2019 and is now included on Table B2-1. Since discovery of the site, Dow has been investigating assessing approaches to source area reduction.

A field-scale pilot study was proposed and implemented in 2019 in the B-Sewer MH B108 AOC. The study was designed to meet the following objectives:

- Confirm field-scale applicability of ISGS to stabilize DNAPL material in the study area.
- Evaluate the field-scale implementation issues.
- Provide an overall proof-of-concept for potential application of this technology in other areas of the facility.
- Demonstrate the ability/efficacy of ISGS amendment to:
 - Provide for comparable hydraulic conductivity and resultant mass flux decreases on a field scale (compared to bench-scale).
 - Provide comparable contaminant concentration decreases on a field scale (compared to bench-scale)
 - Effectively address the entire B-Sewer MH B108 area and resulting impacts.

- Evaluate field scale application methodology for ISGS amendment with respect to injection spacing; radius of influence (ROI); overall ability to implement the technology; and costs related to future full-scale projects.

Further details of the pilot study and design, implementation and results can be found detailed in Section 15.0.

4.0 RGIS UPGRADES

The RGIS was originally installed between 1980 and 1992 along the banks of the Tittabawassee River and around the Tertiary Pond in Midland Plant. Starting in 1994, sections of RGIS were upgraded to enhance performance and extend their operational life. The last upgrade was in 2016 and included tile replacement between LS#13 and MH3A as well as river bank capping from LS#102 through the area of tile replacement.

The next planned upgrade project is designated as the RGIS LS #104 to LS #105 Tile Upgrade Project (Figure 4-1). Dow currently anticipates construction during 2021 or 2022; however, that is dependent upon other projects, including the work at 1925 landfill described in Section 3.1, and the construction schedule may be adjusted.

Major tasks to support this work were completed in 2016 to support the design and planning of these construction activities including a hydrogeological soils investigation and chemical characterization of soils. Chemical characterization data was also collected and submitted in previous quarterly environmental reports. Soils were investigated by completing 10 geotechnical soil borings ranging in depth from 18 to 38 ft below ground surface (bgs). A field geologist identified the soils by logging with continuous split-spoon sampling. Soil boring logs were included in the *2017 Annual Corrective Action Implementation Summary Report and 2018 Work Plan* (2017 CAIP). Twenty-three soil samples were obtained using split-spoon liners and tested for index properties to establish ranges of key design parameters.

In general, all work will be performed in accordance with the detailed specifications that have been used and approved by the MDEQ on past RGIS upgrade projects, as well as Appendix A of Attachment 19 of the Operating License issued September 25, 2015.

The major scope items proposed for this project include:

- Installation of a new concrete sump/lift station to replace existing Lift Station #105;
- Installing just under 2,300 ft of new 8-inch diameter, SDR 21, perforated, high-density polyethylene (HDPE) pipe and drainage media;
- Constructing four new piezometer clusters, including automated primary piezometers;
- Installation of a composite cap and access roadway over the drainage media; and
- Use of a temporary gravel construction roadway outboard the existing sheet piling for access during construction.

Dow currently anticipates completing this work over two construction seasons. The first year will likely include installation of the new lift station and approximately 30% of the drainage media and perforated pipe, composite cap and relevant piezometer clusters. The second year of construction will complete the installation of the drainage media, composite cap and relevant piezometer clusters. At both the end of the first construction season and the end of the project, the site will be restored prior to the winter.

The Project Site is located along the Eastern bank of the Tittabawassee River, approximately 940 ft downstream of the Dow Dam in Section 28 of Midland Township (T14N, R2E), Michigan (Figure 3-1). The Site includes an approximately 2,277-foot (ft) excavation beginning roughly at existing LS #104 and extending southeast to new LS #105, being the new proposed downstream leg for LS #104 and upstream leg for LS #105. The site ranges in elevation from 595 to 598 ft (referenced to North American Vertical Datum [NAVD] 29). This project will help prevent upland groundwater from migrating to the Tittabawassee River.

A new groundwater collection tile and permeable cutoff wall (french drain) will be installed by excavating an approximately 30-inch wide trench and installing filter stone (drainage media) and an 8-inch perforated HDPE collection pipe (tile). The upper portion of the trench will be backfilled with natural soils that were excavated and stockpiled from the trench. The natural soils backfill portion of the system will be isolated from the drainage media by a geosynthetic clay liner (GCL). Design drawings were previously included in the 2017 CAIP.

5.0 MIDLAND PLANT FACILITY-WIDE VAPOR INTRUSION PATHWAY

The intent of the vapor intrusion (VI) evaluation process is to achieve the human exposures control environmental indicator (EI) determination. A “Current Human Exposure Under Control” determination is a means of evaluating the acceptability of current site conditions and interim milestones met and does not address whether corrective action is complete at the site, whether remedial long-term goals are met or whether site conditions will be protective if land uses change in the future. Furthermore, this evaluation process determines if the VI pathway is considered “complete” for each building. If the evaluation process concludes that there is a complete VI pathway for a building, further analysis is conducted to assess potential human exposure to determine whether there is a basis for undertaking a response action.

As the Midland Plant site is an active chemical production facility with many chemicals stored and/or routinely used in the buildings, it is anticipated that in many cases concentrations of vapor-forming chemicals present in the indoor environment may be due to the active occupational setting. If it is determined that the chemical concentrations of vapor-forming chemicals present in the indoor environment are due to use or storage within the building or facility, then the Michigan Compiled Laws Section 324.20120a(18) is appropriate to demonstrate compliance with indoor air inhalation criteria. Under these circumstances, the Occupational Exposure Limits (OELs) are the appropriate risk-based levels to assess potential human exposure and will comply with MIOSHA requirements.

If it is determined that the presence of the chemical is related to a historic environmental release, then the VI evaluation process will utilize the August 2017 Media-Specific Volatilization to Indoor Air Interim Action Screening Levels and/or the June 22, 2018, draft project-specific screening levels provided by Michigan Department of Environment, Great Lakes, and Energy (EGLE) to further assess potential human exposure to that concentration.

5.1 VI Pathway Methodology and Program Update

Currently, the facility has approximately 700 buildings and structures on-site. Indoor air at the facility is being evaluated in a phased approach by zone using a building categorization procedure to consider a worst-case approach to prioritize buildings for investigation and using a weight of evidence framework for assessing the VI pathway. The zones identified to date are shown on Figure 5-1. The building categorization flowchart is presented on Figure 5-2. Category 1 and 2 buildings are priority buildings and are being sampled throughout the facility during the phased approach. Category 3 buildings are deferred until all priority buildings are sampled and evaluated. Category 4 and 5 buildings are not sampled or included in the VI investigation. All buildings categorized to date are listed in Table 5-1. The 2018 Revised VI Workplan (August 2018) documented the general sampling and evaluation methodology. The updated *Process for Evaluating VI and Determination of Path Forward Flowchart* is presented on Figure 5-3. Table 5-2 shows the *Path Forward Building Group Notification and Reporting*.

A Site-Specific Chemical Facility Potential Features Conceptual Site Model (CSM) is provided as Figure 5-4. This figure illustrates general features that are specific to an active industrial chemical facility, such as potential upwind emission sources and a potential pathway from the chemical waste sewer. Detailed building-specific CSMs were developed for buildings that have completed VI seasonal confirmation sampling and are referenced within the building-specific report sections.

VI Sampling Methodology

Following the *Process for Evaluating VI and Determination of Path Forward Flowchart* on Figure 5-3, and the *Path Forward Building Group Notification and Reporting* in Table 5-2, Group 2 and Group 4 buildings undergo seasonal confirmation sampling, which entails four total sampling events. Multiple seasonal sampling events account for any potential seasonal variability (i.e., spring, summer, fall, and winter).

During these seasonal events, confirmation samples will be collected at the same locations as the initial event (for all buildings under 43,000 square feet [ft²]). For large buildings (> 43,000 ft²), sampling locations may be modified in order to best investigate the subject analyte(s) of interest (AOI(s)). After completion of the four seasonal confirmation sampling events, the data will be evaluated and buildings will be recommended for interim monitoring, continued sampling, mitigation, or other interim or long-term actions, as necessary.

VI Interim Monitoring Methodology

Dow implements an Interim Monitoring Plan for each building that has completed seasonal confirmation sampling until a revised program or more permanent Corrective Action Plan is developed for the site. Interim monitoring will be performed semi-annually for a minimum of two years and monitoring results will undergo trend analysis. If results continue to be consistent and below screening levels, monitoring will be conducted on an annual basis. If indoor air results are observed to be increasing, further evaluation will be performed, which may include collection of a sub-slab soil gas sample(s) and an increase in monitoring frequency. Results from each monitoring event will be reported in the annual Corrective Action Implementation Summary Report and Work Plan (CAIP).

In the event an indoor air result(s) exceeds screening levels, EGLE will be provided a brief email notification. A collocated indoor air and sub-slab soil gas sample will be collected from that location within 45 days. If both sub-slab soil gas and indoor air results indicate that VI continues to be insignificant, monitoring will continue at an appropriate frequency. If both sub-slab soil gas and indoor air results indicate that VI is significant and confirm Group 4 conditions, the building will be moved to Group 4 for follow-up actions.

Dow may propose changes to the frequency or other aspects of this Interim Monitoring Plan in the future based on an evaluation of the data, changes in building use or implementation of other corrective actions to address the potential VI pathway.

Occupancy Change and New Construction Monitoring

Buildings originally placed in Category 3 (sampling deferred due to limited occupancy) and buildings categorized as unoccupied in Category 5B will be monitored for a change in use that requires occupancy (Figure 5-2). At a minimum, use will be verified on an annual basis. If a building becomes occupied, the building will be surveyed and considered for sampling. If sampling is warranted, the building will be documented as an "Add-on" building within the appropriate Zone.

The buildings listed in the table below have undergone occupancy changes and have been recategorized and identified as "Add-on" buildings that will be sampled and evaluated for VI in 2020.

Building Number	Building Name	Category	Zone	Phase
31	31 Building	1A	Zone 2	Phase 2 - Add-on
649	Dow Automotive Warehouse	2B	Zone 3	Phase 1 - Add-on
971	Granular Form Plant & Warehouse	2B	Zone 2	Phase 1 - Add-on
1000	Building not named	2A	Zone 2	Phase 1 - Add-on
1004	858 Pipe Coverers Work Area	2C	Zone 2	Phase 1 - Add-on
1015	Storage Warehouse	2B	Zone 2	Phase 1 - Add-on
1139	Site Logistics Warehouse	2B	Zone 2	Phase 1 - Add-on
1297	Package Boilers	2A	Zone 2	Phase 2 - Add-on
1381	Dow Solar R&D	2B	Zone 3	Phase 1 - Add-on
1382	Dow Solar R&D	2A	Zone 3	Phase 1 - Add-on
780/1363	Building not named	2B	Zone 2	Phase 2 - Add-on

Additionally, construction of new buildings will be monitored. Dependent upon use and location, future building sites may be initially screened for VI. Prior to the construction of a building, soil gas samples will

be collected from the proposed footprint. The number of soil gas samples will be determined by the sample density provided in the Michigan Department of Environmental Quality (MDEQ) May 2013 *Guidance Document for the Vapor Intrusion Pathway* and will be sampled according to the methodology described in Section 2.4.2.

5.1.1 Site-Wide VI Sampling and Evaluation Program Update

Throughout the program, VI has been evaluated on a building-by-building basis. In early 2019, however, the data set compiled to date was examined to look for findings and trends that were repeated across the portfolio of buildings. These data findings were presented at the 29th Association for Environmental Health and Sciences Foundation (AEHS) conference on March 20, 2019 (Eklund, et al).

The data set that was examined included 434 unique indoor air sampling locations across 55 buildings. A total of 875 sample pairs (indoor air and sub-slab soil vapor) were available for these 434 locations. The samples generally had been analyzed for 65 individual volatile organic compounds (VOCs), yielding a data set of 56,875 data pairs.

The findings were compared with the assumptions inherent in the study:

- i. An attenuation factor (α) of 0.03 is appropriate for developing site-specific screening levels for sub-slab soil gas;
- ii. Multiple rounds of testing are needed to characterize sub-slab soil gas;
- iii. Paired samples (soil gas & indoor air) are needed to evaluate potential VI; and
- iv. Building-specific attenuation factor will exhibit seasonal variability.

These assumptions form the null hypothesis, which in other words is the default or status quo position. The null hypothesis generally is assumed to be true until evidence indicates otherwise.

The data evaluation focused on compounds detected at a given building in soil vapor at concentrations $\geq 1,000$ micrograms per cubic meter ($\mu\text{g}/\text{m}^3$) at one or more locations. It was thought that these data would give the clearest signal regarding attenuation factors and seasonal variability. This censoring of the data still resulted in a robust data set. One or more VOCs were detected at $\geq 1,000 \mu\text{g}/\text{m}^3$ in soil vapor at 44 of the 55 buildings. Up to 15 individual VOCs were detected at $\geq 1,000 \mu\text{g}/\text{m}^3$ for a single building, with an average of five VOCs per building meeting this criterion. The distribution of maximum soil gas concentration is shown in Figure 1.

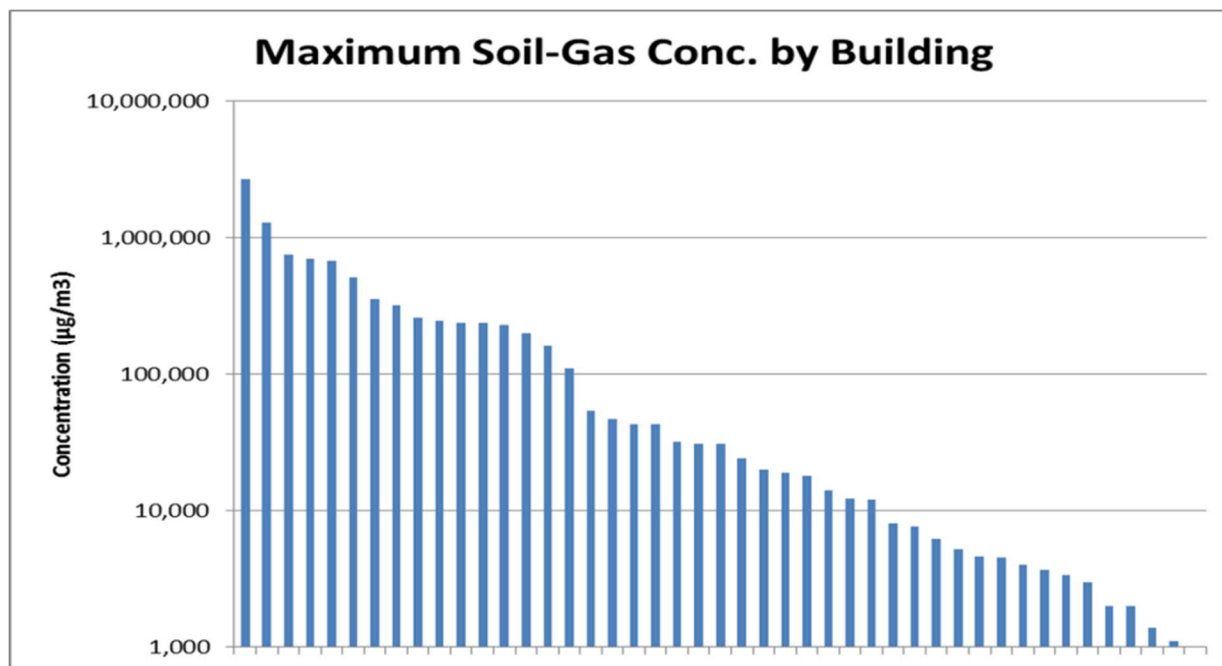
Figure 1. Distribution of Maximum Soil Gas Concentration by Building

There were similarities in which VOC was detected at the highest concentration for each building. One of the five VOCs listed below was the highest detection at 38 of the 44 buildings:

- Chlorofluorocarbon (CFC)-12 (18 buildings);
- Tetrachloroethene (PCE) (11 buildings);
- Xylenes (5 buildings);
- 1,1,1-Trichloroethane (TCA) (2 buildings); or
- Benzene (2 buildings).

Buildings tended to have one or more “hot spots” or locations with relatively high concentrations whereas other areas were relatively clean; i.e., spatial variability was large.

The results show that the detected soil-vapor concentrations were relatively constant across all four seasons of testing. Examples for three buildings are shown in Figures 2, 3 and 4, with multiple locations and multiple VOCs shown for each building.

No buildings exhibited an upward trend in soil-gas concentration over the four rounds of testing. The data were reviewed to determine what the effect would have been if only the first round of testing had been performed. It was found that this would introduce a potential bias, at worst, of only a factor of three. In other words, the maximum concentration during rounds 2, 3, and 4 were never more than three-times the first round result. This suggests that one round of testing is sufficient to characterize soil gas and that seasonal variability could be evaluated by testing only indoor air.

Figure 2. Soil-Vapor Concentration vs. Season for Building 1335

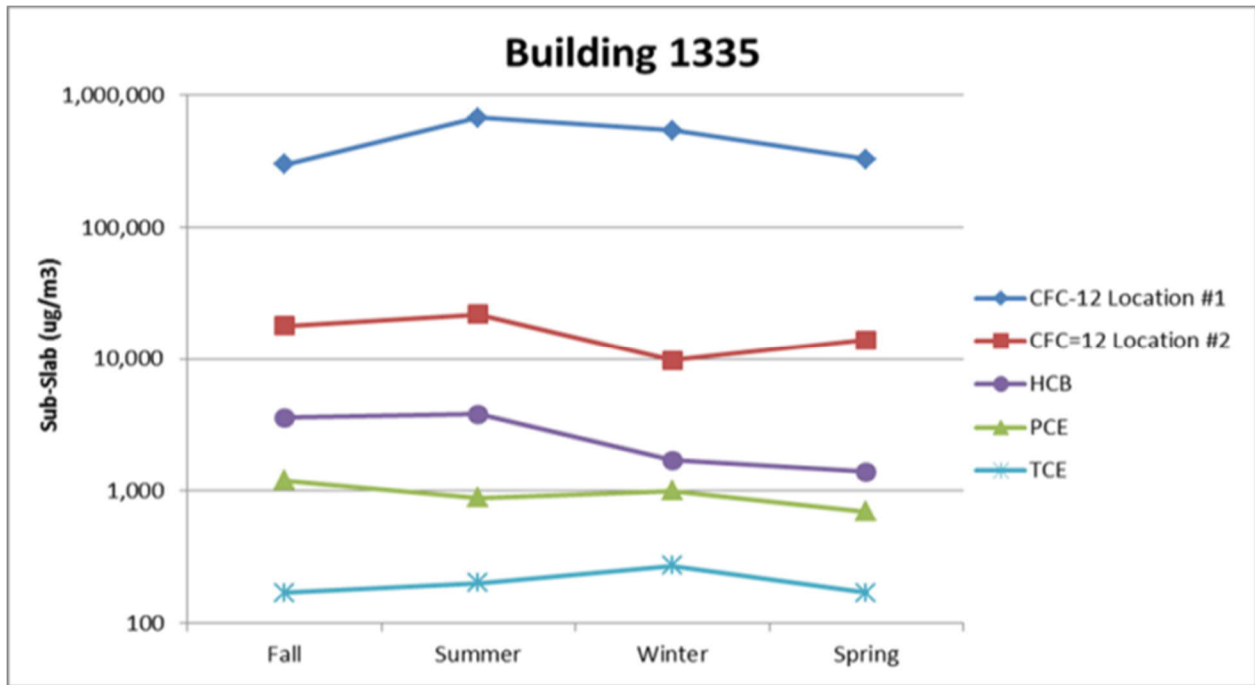

Figure 3. Soil-Vapor Concentration vs. Season for Building 462

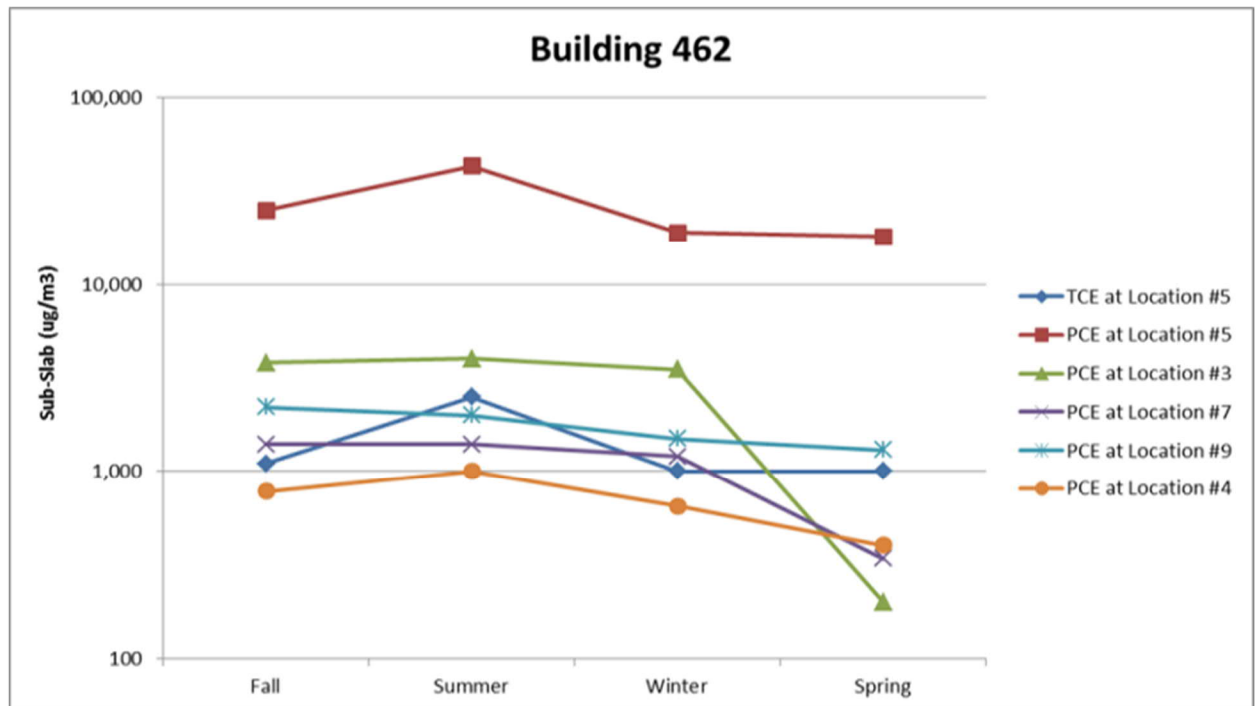
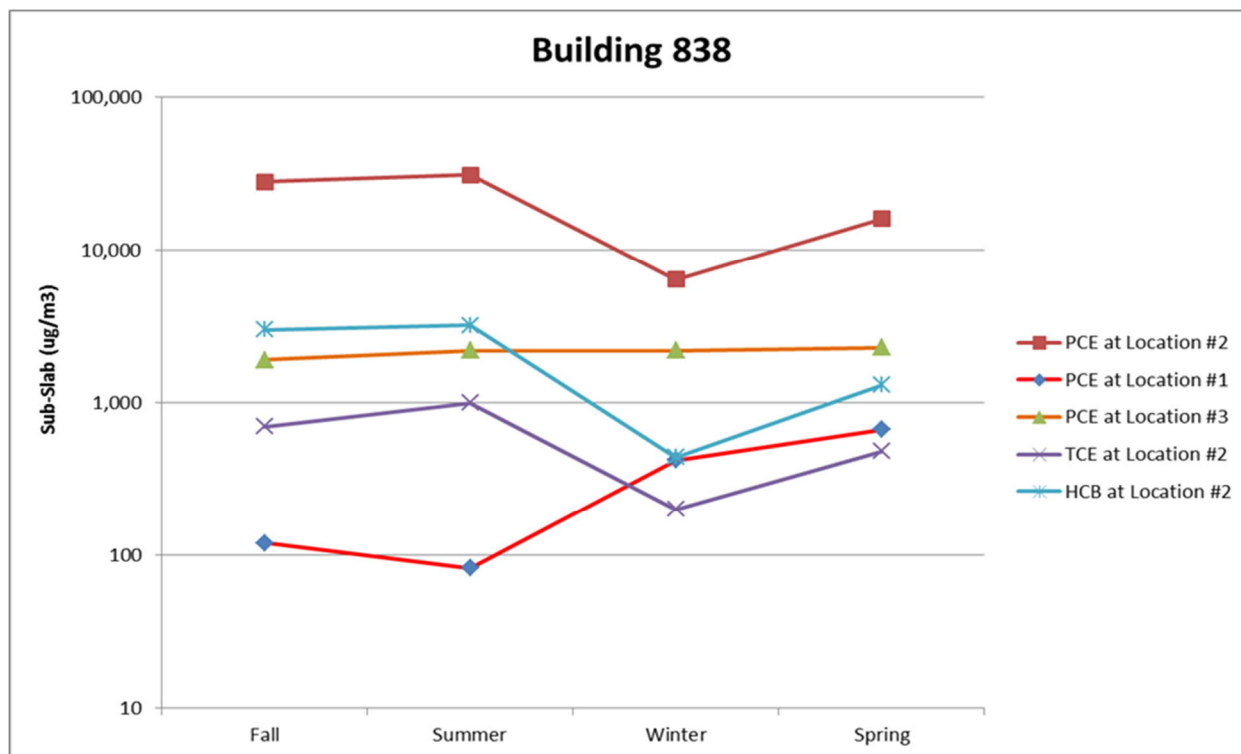

Figure 4. Soil-Vapor Concentration vs. Season for Building 838



A few buildings exhibited a downward trend in soil-gas concentration. For example, at Building 680 the VOCs present at relatively high concentrations declined as shown in Figure 5. In contrast, the VOCs at lower concentrations at this same building were more constant as shown in Figure 6. The reason or reasons for this divergence in behavior is not known.

Figure 5. Relatively High Soil-Vapor Concentrations vs. Season for Building 680

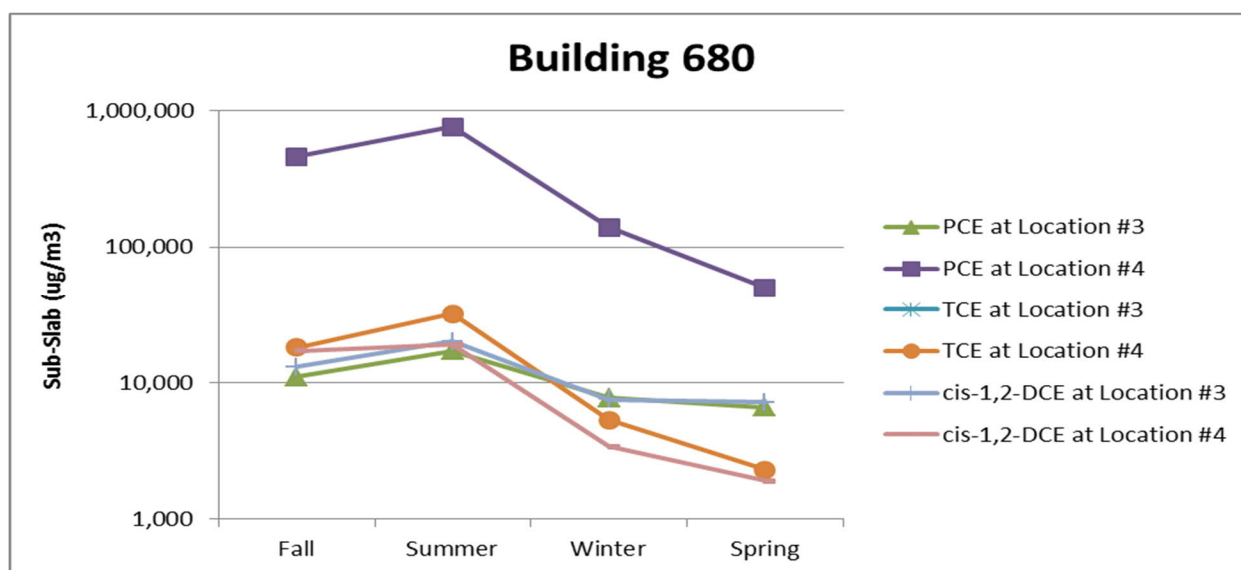
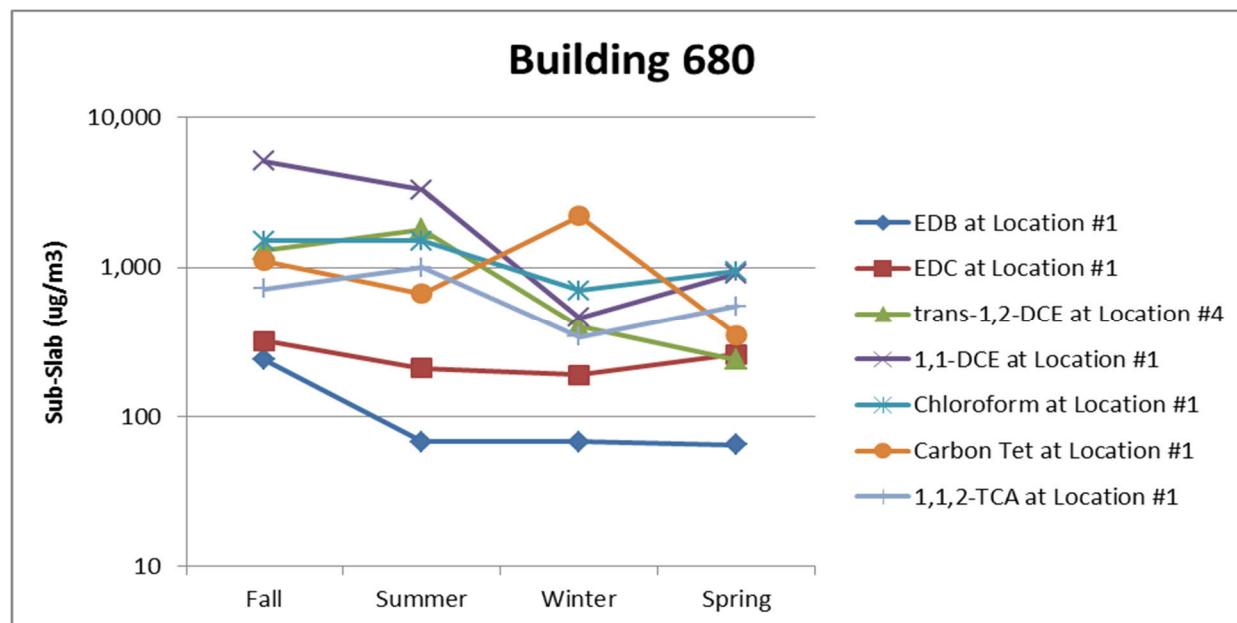
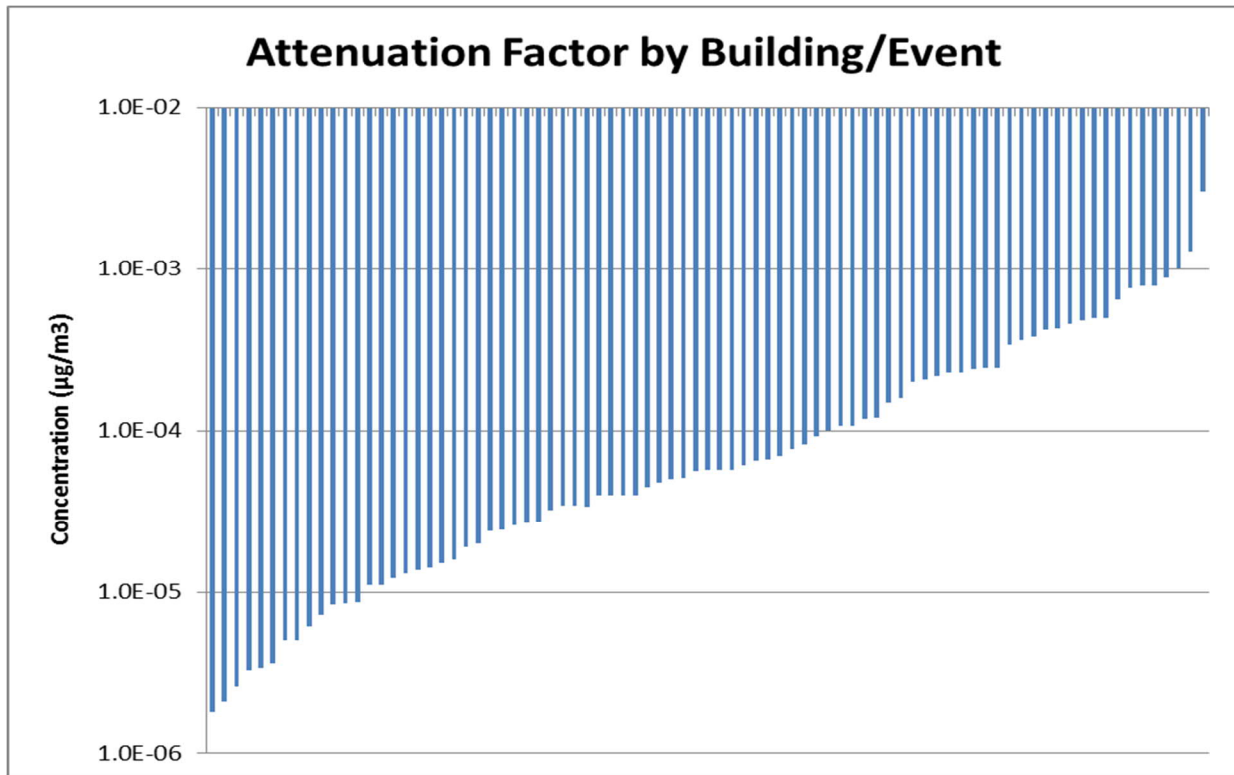

Figure 6. Relatively Low Soil-Vapor Concentrations vs. Season for Building 680

The evaluation of attenuation factor also focused on buildings with soil-gas concentrations $\geq 1,000 \mu\text{g}/\text{m}^3$. Attenuation factors were calculated for each building using maximum values for the building (other options would have been to use average values or to calculate an attenuation factor for each data pair). This approach avoided issues with varying detection limits and small data sets. The indoor air results were not adjusted for outdoor air contribution except where obvious bias was introduced by outdoor air. Data for all VOCs were evaluated and a building-specific attenuation factor was developed for each round of testing.

The data set was examined to find the smallest attenuation factor for each building for each round of testing. This value was assumed to best represent the actual attenuation at that building and was termed the "building-specific" attenuation factor. Other VOCs at the same building often exhibited a similar degree of attenuation but where less attenuation was observed this generally appeared to be the result on indoor emission sources.

A total of 83 building-specific attenuation factors were calculated. The results yield the distribution shown in Figure 7. There were no values as high as the default assumption of 0.03 and the few values that were $> 1\text{E-}03$ had identifiable causes (e.g., indoor emission sources). The median value was $5.7\text{E-}05$ (i.e., 522-times more attenuation than the assumed value).

Figure 7. Distribution of Attenuation Factor by Building & Round of Testing

The attenuation factors as a function of season are shown in Figure 8. There is no readily apparent seasonal variability. There is no obvious increase for wintertime versus summertime values. For residential, single-family buildings, wintertime has been shown to have higher rates of VI than summertime, but this is not the case for these large, industrial buildings. This presumably is due to differences in how industrial buildings are heated compared with single-family residential buildings and the resulting differences in differential pressure (ΔP) across the building slabs.

Figure 8. Attenuation Factor vs. Season for Various Buildings

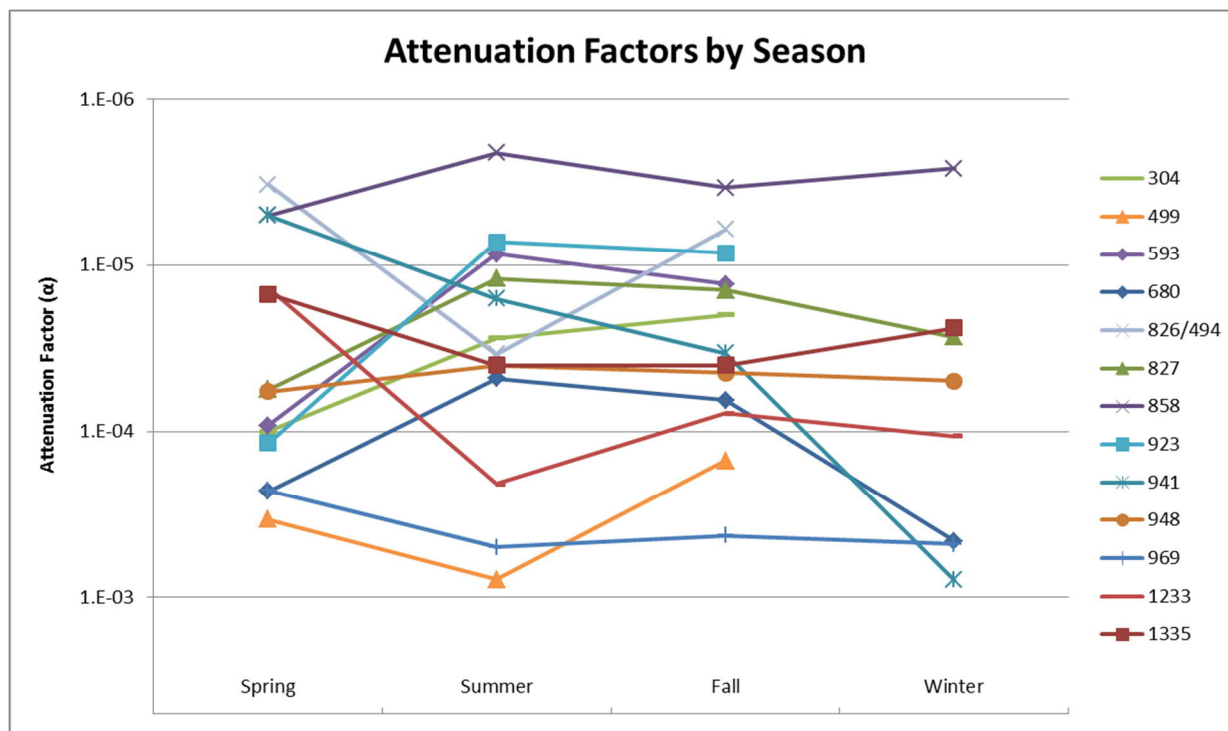

The examination of data on a site-wide basis showed that certain findings were consistent across the entire portfolio of buildings. The findings of the site-wide evaluation were:

1. Sub-slab soil vapor is not homogenously distributed beneath buildings;
2. Seasonal variability in soil-vapor concentrations is minimal;
3. Four rounds of testing do not provide substantially more information regarding soil vapor than one round of testing;
4. Attenuation factors of 0.03 over-predict indoor air impacts by orders of magnitude; and
5. Seasonal variability in attenuation factor also appears to be minimal.

Since the completion of this analysis presented in March 2019, seasonal confirmation sampling has continued at the facility. This analysis was performed for five Zone 1 buildings. For example, Zone 1 Building 680 has completed seven total events of sampling and the up to date trend analysis is provided in Section 5.2.4. Additionally, 16 Zone 2 buildings and 1 Zone 3 building have up to date trend analysis provided in this report.

5.1.2 VI Sampling Status Summary

The following table summarizes the status and path forward building group for each of the priority buildings sampled to date. All buildings that have undergone VI sampling in Zone 1, Zone 2, and Zone 3 Phase 1 and Phase 2 are included below:

Category ^A	Building	VI Path Forward Group ^B	Report Section	Status
Zone 1				
Category 1	1078	1	--	NFA at this time
Category 1	1100	1	--	NFA at this time
Category 1	1358	1	--	NFA at this time
Category 1	3303	1	--	NFA at this time
Category 1	34	2	5.2.1	Seasonal confirmation sampling complete and evaluated in 2018 CAIP. Interim monitoring plan implemented for semi-annual indoor air sample collection.
Category 1	1335	2	5.2.2	Seasonal confirmation sampling complete and evaluated in 2018 CAIP. Interim monitoring plan implemented for semi-annual indoor air sample collection.
Category 2	T1561	1	--	NFA at this time
Category 2	462	2	5.2.3	Seasonal confirmation sampling complete and evaluated in 2018 CAIP. Interim monitoring plan implemented for semi-annual indoor air sample collection.
Category 2	680	4B	5.2.4	Interim action plan/seasonal confirmation sampling continues. Updated trend analysis, summary of further investigation activities (March and May 2019) and interim measures (IMs) complete to date discussed herein.
Category 2	838	2	5.2.5	Seasonal confirmation sampling complete and evaluated in 2018 CAIP. Interim monitoring plan implemented for semi-annual indoor air sample collection.
Category 2	1098	2	5.2.6	Three seasonal confirmation sampling events complete. Final event scheduled for Winter 2019/2020.
Category 2	1159	3	5.2.7	Evaluation provided in 2018 CAIP. Further Investigation activities conducted in July 2019. No evidence of VI.
Zone 2 Phase 1				
Category 1	1	1	--	NFA at this time
Category 1	972	1	--	NFA at this time
Category 1	833	3	5.3.1	Evaluation provided in 2018 CAIP. Further Investigation activities conducted in July 2019. No evidence of VI.
Category 1	941	4B	5.3.2	Expedited Building Summary (EBS) submitted August 2018. Air filtration unit installed. Interim action plan/seasonal confirmation sampling continues. Trend analysis, summary of further investigation activities (March and May 2019) and IMs complete to date discussed herein.
Category 1	1028	2	5.3.3	Seasonal confirmation sampling complete and evaluation included herein. Interim monitoring plan implemented for semi-annual indoor air sample collection.
Category 1	1233	2	5.3.4	Seasonal confirmation sampling complete and evaluation included herein. Interim monitoring plan implemented for semi-annual indoor air sample collection.
Category 1	827	4A	5.3.5	Seasonal confirmation sampling complete and evaluation included herein. Further investigation conducted in May and July 2019. Interim monitoring plan implemented for semi-annual indoor air sample collection.
Category 2	477	1	--	NFA at this time
Category 2	489	1	--	NFA at this time
Category 2	934	1	--	NFA at this time
Category 2	948	4A	5.3.6	Seasonal confirmation sampling complete and evaluation included herein. Further investigation conducted in July 2019. Interim monitoring plan implemented for semi-annual indoor air sample collection.
Category 2	1025	2	5.3.7	Three seasonal confirmation sampling events complete. Final event conducted Fall 2019.

Category ^A	Building	VI Path Forward Group ^B	Report Section	Status
Category 2	768	2	5.3.8	Seasonal confirmation sampling complete and evaluation included herein. Interim monitoring plan implemented for semi-annual indoor air sample collection.
Category 2	849	2	5.3.9	Seasonal confirmation sampling complete and evaluation included herein. Interim monitoring plan implemented for semi-annual indoor air sample collection.
Category 2	858	4A	5.3.10	Seasonal confirmation sampling complete and evaluation included herein. Further investigation conducted in October 2019. Interim monitoring plan implemented for semi-annual indoor air sample collection.
Category 2	969	2	5.3.11	Seasonal confirmation sampling complete and evaluation included herein. Interim monitoring plan implemented for semi-annual indoor air sample collection.
Category 2	1222	2	5.3.12	Seasonal confirmation sampling complete and evaluation included herein. Interim monitoring plan implemented for semi-annual indoor air sample collection.
Category 2	1377	3	--	Evaluation provided in 2018 CAIP. Further investigation into indoor air sources will be conducted.
Zone 2 Phase 2				
Category 1	1130	1	--	NFA at this time
Category 1	1215	2	--	Building on Demolition List
Category 1	1255	2	5.4.1	Seasonal confirmation sampling complete and evaluation included herein. Interim monitoring plan implemented for semi-annual indoor air sample collection.
Category 1	1314	1	--	NFA at this time
Category 2	304	4A	5.4.2	Seasonal confirmation sampling complete and evaluation included herein. Further investigation conducted in October 2019. Interim monitoring plan implemented for semi-annual indoor air sample collection.
Category 2	388	1	--	NFA at this time
Category 2	499	4A	5.4.3	Seasonal confirmation sampling complete and evaluation included herein. Further investigation conducted in May 2019. Interim monitoring plan implemented for semi-annual indoor air sample collection.
Category 2	593	4A	5.4.4	Seasonal confirmation sampling complete and evaluation included herein. Further investigation conducted in October 2019. Interim monitoring plan implemented for semi-annual indoor air sample collection.
Category 2	779	1	--	NFA at this time
Category 2	826/494	2	5.4.5	Seasonal confirmation sampling complete and evaluation included herein. Interim monitoring plan implemented for semi-annual indoor air sample collection.
Category 2	921	3	5.4.6	Evaluation provided in 2018 CAIP. Further Investigation activities conducted in July 2019. No evidence of VI.
Category 2	922	1	--	NFA at this time
Category 2	923	4A	5.4.7	Seasonal confirmation sampling complete and evaluation included herein. Interim monitoring plan implemented for semi-annual indoor air sample collection.
Category 2	935	2	5.4.8	Three seasonal confirmation sampling events complete. Final event scheduled for Winter 2019/2020.
Category 2	1312	1	--	NFA at this time
Zone 3 Phase 1				
Category 1	800	1	5.5.1	NFA at this time
Category 1	887	4A	5.5.2	Three seasonal confirmation sampling events complete. Final event scheduled for Winter 2019/2020. EBS submitted February 2019. Further investigation activities conducted May, July and October 2019.

Category ^A	Building	VI Path Forward Group ^B	Report Section	Status
Category 1	954	1	5.5.3	NFA at this time
Category 1	1038	2	5.5.4	Three seasonal confirmation sampling events complete. Final event scheduled for Winter 2019/2020.
Category 1	1131	1	5.5.5	NFA at this time
Category 2	100	2	5.5.6	Three seasonal confirmation sampling events complete. Final event scheduled for Winter 2019/2020.
Category 2	564	4A	5.5.7	Seasonal confirmation sampling complete and evaluation included herein. Further investigation activities conducted May 2019. Interim monitoring plan implemented for semi-annual indoor air sample collection.
Category 2	881	4A	5.5.8	Three seasonal confirmation sampling events complete. Final event scheduled for Winter 2019/2020. EBS submitted February 2019. Further investigation activities conducted May and July 2019.
Category 2	1037	2	5.5.9	Three seasonal confirmation sampling events complete. Final event scheduled for Winter 2019/2020.
Category 2	1042	2	5.5.10	Three seasonal confirmation sampling events complete. Final event scheduled for Winter 2019/2020.
Zone 3 Phase 2				
Category 1	677		--	Building on Demolition List
Category 1	734	TBD	5.6.1	Samples collected Fall 2019. Evaluation will be provided in 2020 CAIP. Notification and reporting following Table 5-2 will occur, as necessary, based on results.
Category 1	938	TBD	5.6.2	Samples collected Fall 2019. Evaluation will be provided in 2020 CAIP. Notification and reporting following Table 5-2 will occur, as necessary, based on results.
Category 1	990	TBD	5.6.3	Samples collected Fall 2019. Evaluation will be provided in 2020 CAIP. Notification and reporting following Table 5-2 will occur, as necessary, based on results.
Category 1	1018	TBD	5.6.4	Samples collected Fall 2019. Evaluation will be provided in 2020 CAIP. Notification and reporting following Table 5-2 will occur, as necessary, based on results.
Category 1	1385	TBD	5.6.5	Samples collected Fall 2019. Evaluation will be provided in 2020 CAIP. Notification and reporting following Table 5-2 will occur, as necessary, based on results.
Category 1	439/T-1411	TBD	5.6.6	Samples collected Fall 2019. Evaluation will be provided in 2020 CAIP. Notification and reporting following Table 5-2 will occur, as necessary, based on results.
Category 1	732/1300	TBD	5.6.7	Samples collected Fall 2019. Evaluation will be provided in 2020 CAIP. Notification and reporting following Table 5-2 will occur, as necessary, based on results.
Category 1	759/1350	TBD	5.6.8	Samples collected Fall 2019. Evaluation will be provided in 2020 CAIP. Notification and reporting following Table 5-2 will occur, as necessary, based on results.
Category 2	49	4A	5.6.9	EBS submitted December 2019. Samples collected Summer 2019 and evaluated herein. Next seasonal confirmation sampling event scheduled for Winter 2019/2020. Further investigation activities will occur.
Category 2	146	TBD	5.6.10	Samples collected Fall 2019. Evaluation will be provided in 2020 CAIP. Notification and reporting following Table 5-2 will occur, as necessary, based on results.
Category 2	180	TBD	5.6.11	Samples collected Fall 2019. Evaluation will be provided in 2020 CAIP. Notification and reporting following Table 5-2 will occur, as necessary, based on results.
Category 2	298	TBD	5.6.12	Samples collected Fall 2019. Evaluation will be provided in 2020 CAIP. Notification and reporting following Table 5-2 will occur, as necessary, based on results.

Category ^A	Building	VI Path Forward Group ^B	Report Section	Status
Category 2	374	TBD	5.6.13	Samples collected Fall 2019. Evaluation will be provided in 2020 CAIP. Notification and reporting following Table 5-2 will occur, as necessary, based on results.
Category 2	464	TBD	5.6.14	Samples collected Fall 2019. Evaluation will be provided in 2020 CAIP. Notification and reporting following Table 5-2 will occur, as necessary, based on results.
Category 2	638	TBD	5.6.15	Samples collected Fall 2019. Evaluation will be provided in 2020 CAIP. Notification and reporting following Table 5-2 will occur, as necessary, based on results.
Category 2	774	TBD	5.6.16	Samples collected Fall 2019. Evaluation will be provided in 2020 CAIP. Notification and reporting following Table 5-2 will occur, as necessary, based on results.
Category 2	1269	TBD	5.6.17	Samples collected Fall 2019. Evaluation will be provided in 2020 CAIP. Notification and reporting following Table 5-2 will occur, as necessary, based on results.
Category 2	27/313/803	TBD	5.6.18	Samples collected Fall 2019. Evaluation will be provided in 2020 CAIP. Notification and reporting following Table 5-2 will occur, as necessary, based on results.
Category 2	458/963	TBD	5.6.19	Samples collected Fall 2019. Evaluation will be provided in 2020 CAIP. Notification and reporting following Table 5-2 will occur, as necessary, based on results.
Category 2	542/561	TBD	5.6.20	Samples collected Fall 2019. Evaluation will be provided in 2020 CAIP. Notification and reporting following Table 5-2 will occur, as necessary, based on results.
Category 2	719/1360	TBD	5.6.21	Samples collected Fall 2019. Evaluation will be provided in 2020 CAIP. Notification and reporting following Table 5-2 will occur, as necessary, based on results.

^A Figure 5-2.

^B Figure 5-3.

CAIP - Corrective Action Implementation Summary Report and Work Plan.

EBS - Expedited Building Summary.

NFA - No Further Action.

TBD - To Be Determined.

VI - Vapor Intrusion.

5.2 Zone 1 Evaluations and Updates

The Zone 1 buildings were evaluated in the 2017 CAIP (December 2017), the 2018 Vapor Intrusion Rescreen of Zone 1 and Zone 2 Phase 1 Report (August 2018), and in the 2018 CAIP (January 2019). Zone 1 sampling and/or interim monitoring results are presented for the buildings listed below in the following subsections:

- Section 5.2.1 Building 34;
- Section 5.2.2 Building 1335;
- Section 5.2.3 Building 462;
- Section 5.2.4 Building 680;
- Section 5.2.5 Building 838;
- Section 5.2.6 Building 1098; and
- Section 5.2.7 Building 1159.

5.2.1 Building 34 Interim Monitoring Results Summary

Building 34 is a Category 1 building located within the southwest portion of the facility designated as Zone 1 and is known as the Rotary Kiln Incinerator Admin/Control Room. Building 34 is a Group 2 building that completed seasonal confirmation sampling in May 2018. A full evaluation and trend analysis was provided in the 2018 CAIP. All indoor air analytes were detected below screening levels during each of the seasonal confirmation sampling events. The sub-slab soil gas AOIs are trichloroethene (TCE), 1,2,4-trichlorobenzene (1,2,4-TCB), 1,3-dichlorobenzene (1,3-DCB), 1,4-DCB, hexachlorobutadiene (HCB), and naphthalene due to exceedances of the draft project-specific RIASL₁₂. 1,2,4-TCB also exceeded the TSRIASL₁₂ in sub-slab soil gas.

Based on the evaluation of the four seasonal confirmation sampling events, the VI pathway is insignificant for Building 34 and the sub-slab soil gas results demonstrated a decrease in concentrations over time. There was no evidence of increasing concentrations over time for any of the chlorinated hydrocarbons. Sufficient information exists to make a human exposure under control EI determination. However, while currently there is no evidence of potential VI, for future use, long-term monitoring (LTM) was warranted and the building-specific Interim Monitoring Plan was implemented.

Indoor air is monitored at location 34-IA-01. This location was selected for continued monitoring since it demonstrated the highest sub-slab soil gas results. Monitoring is performed for TCE, 1,2,4-TCB, 1,3-DCB, 1,4-DCB, HCB, and naphthalene. Interim monitoring occurs semi-annually and the initial event was conducted in August 2019. The indoor air results are shown below.

Indoor Air Analyte	Result Value ($\mu\text{g}/\text{m}^3$)	Reporting Limit ($\mu\text{g}/\text{m}^3$)	EGLE Project- Specific RIASL ₁₂ ($\mu\text{g}/\text{m}^3$)	NONRES TSRIASL ₁₂ ($\mu\text{g}/\text{m}^3$)	Dow IH OEL (8-hour Time Weighted Average) ($\mu\text{g}/\text{m}^3$)
1,2,4-Trichlorobenzene	ND	6.6	6.2	19	37,100
1,3-Dichlorobenzene	ND	1.1	9.2	28	60,100
1,4-Dichlorobenzene	ND	0.21	30	300	60,100
Hexachlorobutadiene	ND	3.8	5.4	NA	213
Naphthalene	ND	0.47	3.6	NA	52,400
Trichloroethene	ND	0.19	4	12	26,850

As shown on the table above, all indoor air results from the Summer 2019 IM event were non-detect (ND) with reporting limits (RLs) below the indoor air RIASL₁₂, with the exception of 1,2,4-TCB which had a ND RL slightly above the RIASL₁₂. The analytical data is presented in Appendix A. Field sampling forms are provided in Appendix B. The next interim measure (IM) event is scheduled for Winter 2019/2020. Semi-annual interim monitoring will continue in the summer and winter of 2020.

5.2.2 Building 1335 Interim Monitoring Results Summary

Building 1335 is a Category 1 building located within the southeast portion of the facility designated as Zone 1. It is known as the 23 Gatehouse or Contractor Gate and is a small building that includes space utilized by security personnel and visitors checking into the facility. Building 1335 is a Group 2 building that completed seasonal confirmation sampling in April 2018. A full evaluation and trend analysis was provided in the 2018 CAIP. All indoor air analytes were detected below screening levels during each of the seasonal confirmation sampling events. The sub-slab soil gas AOIs are CFC-12, HCBd, and TCE due to exceedances of the draft project-specific RIASL₁₂. There were no sub-slab soil gas results above the TSRIASL₁₂ at Building 1335.

Based on the evaluation of the four seasonal confirmation sampling events, the VI pathway is insignificant for Building 1335 and the sub-slab soil gas results demonstrated relatively stable concentrations and no evidence of increasing over time. Sufficient information exists to make a human exposure under control EI determination. However, while currently there is no evidence of potential VI, for future use, LTM was warranted and the building-specific Interim Monitoring Plan was implemented.

Indoor air is monitored at location 1335-IA-01. This location was selected for continued monitoring since it demonstrated the highest sub-slab soil gas results. Monitoring is performed for CFC-12, HCBd, and TCE. Interim monitoring occurs semi-annually and the initial event was completed in August 2019. The indoor air results are shown below.

Indoor Air Analyte	Result Value ($\mu\text{g}/\text{m}^3$)	Reporting Limit ($\mu\text{g}/\text{m}^3$)	EGLE Project- Specific RIASL ₁₂ ($\mu\text{g}/\text{m}^3$)	NONRES TSRIASL ₁₂ ($\mu\text{g}/\text{m}^3$)	Dow IH OEL (8-hour Time Weighted Average) ($\mu\text{g}/\text{m}^3$)
CFC-12	3	--	1,020	NA	4,950,000
Hexachlorobutadiene	ND	9	5.4	NA	213
Trichloroethene	ND	0.18	4	12	26,850

As shown on the table above, all indoor air results from the Summer 2019 IM event were detected below the screening levels or ND with RLs below the indoor air RIASL₁₂, with the exception of HCBd which had a ND RL slightly above the RIASL₁₂. The analytical data is presented in Appendix A. Field sampling forms are provided in Appendix B. The next IM event is scheduled for Winter 2019/2020. Semi-annual interim monitoring will continue in the summer and winter of 2020.

5.2.3 Building 462 Interim Monitoring Results Summary

Building 462 is a Category 2 building located north of the Wastewater Treatment Plant (WWTP) within the southern portion of the facility designated as Zone 1. It is known as the Maintenance/Repair/Operations (MRO)/Investment Recovery Building and is a large warehouse that also contains office space and a shop. Building 462 is a Group 2 building that completed seasonal confirmation sampling in May 2018. A full evaluation and trend analysis was provided in the 2018 CAIP. All indoor air analytes were detected below screening levels during each of the seasonal confirmation sampling events. The sub-slab soil gas AOIs are PCE and TCE due to exceedances of the draft project-specific RIASL₁₂ and the TSRIASL₁₂.

Based on the evaluation of the four seasonal confirmation sampling events, the VI pathway is insignificant for Building 462 and the sub-slab soil gas results exhibited relatively stable concentrations and no evidence of increasing over time. Sufficient information exists to make a human exposure under control EI determination. However, while currently there is no evidence of potential VI, for future use, LTM was warranted and the building-specific Interim Monitoring Plan was implemented.

Indoor air is monitored at locations 462-IA-03 and 462-IA-05. These locations were selected for continued monitoring since they demonstrated the highest sub-slab soil gas results. Monitoring is performed for PCE and TCE. Interim monitoring is performed semi-annually and the initial event was conducted in August 2019. The indoor air results are shown below.

Indoor Air Analyte	Result Value (µg/m ³)	Reporting Limit (µg/m ³)	EGLE Project-Specific RIASL ₁₂ (µg/m ³)	NONRES TSRIASL ₁₂ (µg/m ³)	Dow IH OEL (8-hour Time Weighted Average) (µg/m ³)
<i>Sample 462-IA-03</i>					
Tetrachloroethene	2.4	--	82	82	67,800
Trichloroethene	0.23	--	4	12	26,850
<i>Sample 462-IA-05</i>					
Tetrachloroethene	3.8	--	82	82	67,800
Trichloroethene	0.36	--	4	12	26,850

As shown on the table above, all indoor air results from the Summer 2019 IM event were ND with RLs below the indoor air RIASL₁₂. The analytical data is presented in Appendix A. Field sampling forms are provided in Appendix B. The next IM event is scheduled for Winter 2019/2020. Semi-annual interim monitoring will continue in the summer and winter of 2020.

5.2.4 VI Seasonal Confirmation Sampling Results Evaluation for Building 680

INTRODUCTION

Building 680 is a Category 2 building located within the southwest portion of the facility designated as Zone 1 (Figure 5.2.4.1). It is known as the Sulfonamides Building. The initial evaluation in the 2017 CAIP placed Building 680 in VI Path Forward Building Group 2. Group 2 is a designation for buildings that have sub-slab soil gas AOIs, but where initial indoor air results were all less than screening levels. Any building placed in Group 2 is scheduled for seasonal confirmation sampling events. The results of the initial sampling event (E1) and the second seasonal confirmation sampling event (E2) were evaluated in the 2017 CAIP. The 2018 Rescreen included an evaluation of the seasonal sampling conducted through E4. The findings of the 2018 Rescreen acknowledged that some level of VI was occurring for TCE and Building 680 was moved to VI Path Forward Building Group 4. Section 5.2.4 of the 2018 CAIP included an evaluation and trend analysis for all four seasonal confirmation sampling events. Following the building-specific interim action plan provided in the 2018 CAIP, four additional seasonal confirmation sampling events were performed in 2019.

Building 680	
Initial Sampling Event	Completed
E1	October 2016 (Fall)
Seasonal Confirmation Sampling Event	Completed
E2	August 2017 (Summer)
E3	February 2018 (Winter)
E4	April 2018 (Spring)
E5	February 2019 (Winter)
E6	May 2019 (Spring)
E7	August 2019 (Summer)
<i>E8 - Scheduled</i>	<i>December 2019 (Winter)</i>

Based on EGLE guidance, indoor air and sub-slab soil-gas samples were initially collected during each event at four locations within the building and concurrent outdoor air samples were collected at one location. Four additional sampling locations were added in 2019 (Figure 5.2.4-2). The sub-slab soil gas AOIs are PCE, TCE, cis-1,2-dichloroethene (cis-1,2-DCE), 1,1,2-TCA, 1,2-dichloroethane (EDC), 1,2-dibromoethane (EDB), carbon tetrachloride, chloroform, and HCBd, due to exceedances of the draft project-specific RIASL₁₂ and/or the TSRIASL₁₂. Figures showing results for each sample location are provided for cis-1,2-DCE, PCE, and TCE since these analytes have exceedances in both sub-slab soil gas and indoor air (Figures 680-1 through 680-3, respectively).

VAPOR INTRUSION CONCEPTUAL SITE MODEL

VI is an exposure pathway that involves the migration of volatilized chemicals from the subsurface to indoor air in overlying, occupied buildings. A source, migration route and a human receptor must be present for the VI pathway to be complete. The focus of this building specific investigation is to evaluate the potential VI exposure pathway for Dow employees and contractors at Building 680. The CSM is illustrated in Figure 5.2.4-3.

Building 680 is four stories tall but only has two internal floors. It was constructed in 1960 and contains process areas, office space, a control room, storage areas, a small laboratory, a locker room, and a garage. The building is slab-on-grade construction with a footprint of approximately 8,500 ft² (790 square meters [m²]). The building has central air conditioning (AC) with the air intake at roof level and a steam radiation heating system. There is one bay door left open during the workday in good weather.

The only underground utilities are the sewer lines. There are multiple floor drains and various plumbing fixtures. The land surrounding the building is covered in asphalt and concrete. The depth to groundwater in this area of the facility is approximately 5 feet (ft) below ground surface (bgs) and the soils are largely fill material. Groundwater flow is towards the south or southwest.

The typical parameters for non-residential exposures are assumed to apply to workers at this building (i.e., 40 hours/week, 50 weeks/year exposure).

A building survey was performed on October 14, 2016. Drains and other openings were screened with a photoionization detector (PID) and no soil gas entry points were identified. A chemical inventory was completed during the building survey and a wide variety of chemicals were found (e.g., bleach, various cleaners, wasp spray containing 80-90% petroleum distillates). Chemical storage cabinets within the building contain acetone, dichloromethane, hexane, isopropyl alcohol, methanol, methyl-ethyl ketone (MEK), methylene chloride, and toluene.

Further investigation activities were conducted in March and May 2019 using real-time measurement devices to identify potential pathways for VI. Findings were reported to EGLE in the June 2019 Summary of Investigative Findings (see Appendix C). The goal of the building-specific investigation for Building 680 was to identify potential sources and achieve better spatial resolution of TCE concentrations in the indoor air. During these activities, potential workplace indoor air sources and various potential preferential

pathways were investigated with no significant findings. The investigation led to the identification of joint seams in the shop and the storage room/utilities area where relatively high TCE concentrations were measured. Dow implemented an interim action to seal the joint seams and this activity was completed on April 30, 2019; however, as discussed in the July 2019 Corrective Action status meeting, results indicated that concentrations decreased but not as much as expected.

EVALUATION OF SEASONAL CONFIRMATION SAMPLING EVENTS

This evaluation includes the seven seasonal sampling events (E1-E7) that have been conducted at Building 680. The sampling events encompass three years of time and include sampling during each season of the year. Summary statistics and screening comparison results for each event are presented for sub-slab soil gas on Table 5.2.4-A and indoor and outdoor air on Table 5.2.4-B. The analytical reports are presented in Appendix A. Field sampling logs are provided in Appendix B.

The results from the seven seasonal confirmation sampling events were evaluated with respect to spatial variability, temporal variability, and seasonal trend analysis. Building specific attenuation factors were calculated and compared between events to evaluate temporal variability and determine the best estimate of a building-specific attenuation factor.

This evaluation focused on any analytes detected in the sub-slab soil gas samples that met the criterion for inclusion in one or more of the following categories:

- a) Analytes detected in sub-slab soil gas at concentrations that exceeded draft project-specific screening levels;
- b) Analytes detected in sub-slab soil gas at concentrations of 1,000 $\mu\text{g}/\text{m}^3$ or greater in one or more samples. Data for analytes detected above 1,000 $\mu\text{g}/\text{m}^3$ should provide the clearest signal and be the simplest to interpret when assessing data trends. The same data trends observed for these analytes are expected to apply to other similar analytes present at lower concentrations; and
- c) PCE and TCE. These two analytes are of particular interest for many VI evaluations at industrial sites.

For this building, the analytes detected in the sub-slab soil gas at concentrations above the draft project-specific screening levels were the following 12 analytes: 1,1,2-TCA, 1,1-dichloroethane (DCA), EDB, EDC, 1,2-dichloropropane (DCP), carbon tetrachloride, chloroform, cis-1,2-DCE, HCB, PCE, TCE, and vinyl chloride. Five other analytes of potential interest were detected at concentrations $\geq 1,000 \mu\text{g}/\text{m}^3$ in sub-slab soil gas: trans-1,2-DCE, 1,1-DCE, CFC-12, 1,1,1-TCA, and methylene chloride. In addition, acetone, ethanol, and 1,2,4-trimethylbenzene (TMB) were detected in one sub-slab soil gas sample in E4 at concentrations $\geq 1,000 \mu\text{g}/\text{m}^3$; however, these analytes are not included in this evaluation due to their low detection frequency. Sample results for the analytes included in this evaluation are provided in the data tables below:

Summary of Results for 1,1,2-Trichloroethane (1,1,2-TCA)

Sample Type	Sample ID	Measured Concentration ($\mu\text{g}/\text{m}^3$)						
		Oct. 2016	Aug./Sept. 2017	Feb. 2018	Apr. 2018	Feb. 2019	May 2019	Aug. 2019
		E1	E2	E3	E4	E5	E6	E7
Outdoor Air	680-OA-01	<4.3	<0.17	<0.16	<0.18	<0.18	<0.18	<0.19
Indoor Air	680-IA-01	<4.6	<0.17	<0.19	<0.18	<0.18	<0.19	<0.20
	680-IA-02	<4.3	<0.17	<0.18	<0.18	<0.18	<0.18	<0.20
	680-IA-03	<4.3	<0.18	<0.18	<0.18	<0.17	<0.18	<0.19
	680-IA-04	<4.2	<0.18	<0.18	<0.18	<0.34	<0.88	<0.20
	680-IA-05	--	--	--	--	<0.14	<0.16	<0.21
	680-IA-06	--	--	--	--	<0.17	<0.38	<0.19
	680-IA-07	--	--	--	--	<0.17	<0.18	<0.18
	680-IA-08	--	--	--	--	<0.18	<0.18	<0.19
Sub-Slab Soil Gas	680-SS-01	720	1,000	340	550	370	510	940
	680-SS-02	<4.7	<4.4	<4.4	<4.4	<15	<5.8	<4.2
	680-SS-03	<89	<42	<44	<42	<21	<9.6	<43
	680-SS-04	<240	<550	<280	<150	<78	<17	<400
	680-SS-05	--	--	--	--	<2,400	<2,100	<9,000
	680-SS-06	--	--	--	--	<550	<380	<540
	680-SS-07	--	--	--	--	<4.3	<4	<4.6
	680-SS-08	--	--	--	--	230	330	300

Screening level for indoor air is $0.62 \mu\text{g}/\text{m}^3$ (RIASL₁₂)

Screening level for soil-gas is $20 \mu\text{g}/\text{m}^3$ (RIASL₁₂)

Summary of Results for 1,1-Dichloroethane (1,1-DCA)

Sample Type	Sample ID	Measured Concentration ($\mu\text{g}/\text{m}^3$)						
		Oct. 2016	Aug./Sept. 2017	Feb. 2018	Apr. 2018	Feb. 2019	May 2019	Aug. 2019
		E1	E2	E3	E4	E5	E6	E7
Outdoor Air	680-OA-01	<3.2	<0.13	<0.12	<0.13	<0.12	<0.13	<0.14
Indoor Air	680-IA-01	<3.4	<0.13	<0.14	<0.13	<0.13	<0.13	<0.14
	680-IA-02	<3.2	<0.13	0.13	<0.13	0.18	<0.14	<0.14
	680-IA-03	<3.2	<0.13	<0.13	<0.14	0.17	0.22	<0.14
	680-IA-04	<3.2	0.2	<0.13	<0.14	<0.13	0.50	<0.14
	680-IA-05	--	--	--	--	0.39	2.3	0.18
	680-IA-06	--	--	--	--	0.85	<0.12	<0.16
	680-IA-07	--	--	--	--	1	<0.28	<0.14
	680-IA-08	--	--	--	--	0.12	0.15	<0.14
Sub-Slab Soil Gas	680-SS-01	22	24	<11	11	7.4	14	24
	680-SS-02	96	22	33	7.9	350	47	10
	680-SS-03	<66	100	50	45	<15	<7.1	36
	680-SS-04	570	500	<210	<110	93	<12	520
	680-SS-05	--	--	--	--	8,600	4,500	17,000
	680-SS-06	--	--	--	--	8,600	4,600	8,500
	680-SS-07	--	--	--	--	7.6	12	38
	680-SS-08	--	--	--	--	19	30	34

Screening levels for indoor air are $74 \mu\text{g}/\text{m}^3$ (RIASL₁₂) and $740 \mu\text{g}/\text{m}^3$ (TSRIASL₁₂)

Screening levels for soil-gas are $2500 \mu\text{g}/\text{m}^3$ (RIASL₁₂) and $25000 \mu\text{g}/\text{m}^3$ (TSRIASL₁₂)

	RIASL ₁₂ Exceedance
	TSRIASL ₁₂ Exceedance

Summary of Results for 1,2-Dibromoethane (EDB)

Sample Type	Sample ID	Measured Concentration ($\mu\text{g}/\text{m}^3$)						
		Oct. 2016	Aug./Sept. 2017	Feb. 2018	Apr. 2018	Feb. 2019	May 2019	Aug. 2019
		E1	E2	E3	E4	E5	E6	E7
Outdoor Air	680-OA-01	<6.1	<0.24	<0.22	<0.25	<0.22	<0.25	<0.14
Indoor Air	680-IA-01	<6.4	<0.24	<0.27	<0.25	<0.25	<0.25	<0.13
	680-IA-02	<6.1	<0.24	<0.25	<0.25	<0.25	<0.27	<0.14
	680-IA-03	<6.1	<0.25	<0.25	<0.26	<0.26	<0.26	<0.14
	680-IA-04	<6.0	<0.26	<0.25	<0.26	<0.24	<0.26	<0.13
	680-IA-05	--	--	--	--	<0.48	<1.2	<0.14
	680-IA-06	--	--	--	--	<0.20	<0.23	<0.15
	680-IA-07	--	--	--	--	<0.24	<0.53	<0.13
	680-IA-08	--	--	--	--	<0.24	<0.26	<0.13
Sub-Slab Soil Gas	680-SS-01	240	68	68	65	60	45	970
	680-SS-02	<6.6	<6.2	<6.2	<6.1	<20	<8.2	<5.9
	680-SS-03	<130	<60	<62	<59	<29	<14	<61
	680-SS-04	<340	<770	<400	<210	<110	<24	<560
	680-SS-05	--	--	--	--	<3,400	<3,000	<13,000
	680-SS-06	--	--	--	--	<770	<540	<760
	680-SS-07	--	--	--	--	<6.1	<5.7	<6.5
	680-IA-08	--	--	--	--	<8.1	<30	<26

Screening level for indoor air is $0.2 \mu\text{g}/\text{m}^3$ (RIASL₁₂)Screening level for soil-gas is $6.6 \mu\text{g}/\text{m}^3$ (RIASL₁₂)**Summary of Results for 1,2-Dichloroethane (EDC)**

Sample Type	Sample ID	Measured Concentration ($\mu\text{g}/\text{m}^3$)						
		Oct. 2016	Aug./Sept. 2017	Feb. 2018	Apr. 2018	Feb. 2019	May 2019	Aug. 2019
		E1	E2	E3	E4	E5	E6	E7
Outdoor Air	680-OA-01	<3.2	<0.13	<0.12	<0.13	0.15	<0.13	<0.14
Indoor Air	680-IA-01	<3.4	<0.13	<0.14	<0.13	0.15	<0.13	<0.14
	680-IA-02	<3.2	<0.13	<0.13	<0.13	0.15	<0.14	<0.14
	680-IA-03	<3.2	0.16	<0.13	<0.14	0.15	<0.14	<0.14
	680-IA-04	<3.2	0.20	<0.13	<0.14	0.14	<0.14	<0.14
	680-IA-05	--	--	--	--	<0.25	<0.66	<0.14
	680-IA-06	--	--	--	--	0.18	<0.12	<0.16
	680-IA-07	--	--	--	--	0.18	<0.28	<0.14
	680-IA-08	--	--	--	--	0.16	<0.14	<0.14
Sub-Slab Soil Gas	680-SS-01	320	210	190	260	160	220	380
	680-SS-02	7.9	<3.2	<3.2	<3.2	<11	<4.3	<3.1
	680-SS-03	<66	<31	<32	<31	<15	<7.1	<32
	680-SS-04	850	<410	<210	<110	61	<12	<300
	680-SS-05	--	--	--	--	<1,800	<1,600	<6,700
	680-SS-06	--	--	--	--	<410	<280	<400
	680-SS-07	--	--	--	--	<3.2	<3	<3.4
	680-SS-08	--	--	--	--	63	100	94

Screening level for indoor air is $4.6 \mu\text{g}/\text{m}^3$ (RIASL₁₂)Screening levels for soil-gas is $150 \mu\text{g}/\text{m}^3$ (RIASL₁₂)

	RIASL ₁₂ Exceedance
	TSRIASL ₁₂ Exceedance

Summary of Results for 1,2-Dichloropropane (1,2-DCP)

Sample Type	Sample ID	Measured Concentration ($\mu\text{g}/\text{m}^3$)						
		Oct. 2016	Aug./Sept. 2017	Feb. 2018	Apr. 2018	Feb. 2019	May 2019	Aug. 2019
		E1	E2	E3	E4	E5	E6	E7
Outdoor Air	680-OA-01	<3.7	<0.74	<0.67	<0.76	<0.67	<0.74	<0.83
Indoor Air	680-IA-01	<3.8	<0.73	<0.81	<0.75	<0.76	<0.74	<0.81
	680-IA-02	<3.6	<0.72	<0.74	<0.76	<0.75	<0.8	<0.83
	680-IA-03	<3.6	<0.74	<0.75	<0.77	<0.77	<0.78	<0.83
	680-IA-04	<3.6	<0.78	<0.74	<0.78	<0.72	<0.78	<0.79
	680-IA-05	--	--	--	--	<1.4	<3.7	<0.83
	680-IA-06	--	--	--	--	<0.61	<0.70	<0.90
	680-IA-07	--	--	--	--	<0.74	<1.6	<0.79
	680-IA-08	--	--	--	--	<0.71	<0.78	<0.78
Sub-Slab Soil Gas	680-SS-01	67	80	29	41	33	41	79
	680-SS-02	34	12	11	<3.7	74	6.2	4.8
	680-SS-03	100	110	57	60	23	<8.2	56
	680-SS-04	<210	60	<240	<120	<66	<14	<340
	680-SS-05	--	--	--	--	<2,000	<1,800	<7,700
	680-SS-06	--	--	--	--	1,500	950	1,700
	680-SS-07	--	--	--	--	<3.6	<3.4	6.5
	680-SS-08	--	--	--	--	170	250	280

Screening level for indoor air is $12.2 \mu\text{g}/\text{m}^3$ (RIASL₁₂)

Screening levels for soil-gas is $410 \mu\text{g}/\text{m}^3$ (RIASL₁₂)

Summary of Results for Carbon Tetrachloride

Sample Type	Sample ID	Measured Concentration ($\mu\text{g}/\text{m}^3$)						
		Oct. 2016	Aug./Sept. 2017	Feb. 2018	Apr. 2018	Feb. 2019	May 2019	Aug. 2019
		E1	E2	E3	E4	E5	E6	E7
Outdoor Air	680-OA-01	<5.0	<0.20	0.48	0.42	0.53	0.42	0.44
Indoor Air	680-IA-01	<5.2	<0.20	0.46	0.41	0.52	0.46	0.42
	680-IA-02	<5.0	<0.20	0.51	0.47	0.54	0.47	0.45
	680-IA-03	<5.0	<0.20	0.46	0.46	0.57	0.51	0.45
	680-IA-04	<4.9	0.68	0.47	0.44	0.49	0.51	0.46
	680-IA-05	--	--	--	--	0.52	<1	0.46
	680-IA-06	--	--	--	--	0.57	0.42	0.46
	680-IA-07	--	--	--	--	0.95	0.44	0.44
	680-IA-08	--	--	--	--	0.53	0.48	0.43
Sub-Slab Soil Gas	680-SS-01	1,100	670	2,200	350	230	520	1,300
	680-SS-02	30	8.3	<5.1	<5	130	<6.7	<4.8
	680-SS-03	<100	<49	<51	<48	<24	<11	<50
	680-SS-04	680	1,000	<320	<170	<91	<19	600
	680-SS-05	--	--	--	--	<2,800	<2,400	<10,000
	680-SS-06	--	--	--	--	<630	<440	<620
	680-SS-07	--	--	--	--	<5	<4.6	<5.3
	680-SS-08	--	--	--	--	280	550	500

Screening level for indoor air is $22 \mu\text{g}/\text{m}^3$ (RIASL₁₂)

Screening level for soil-gas is $710 \mu\text{g}/\text{m}^3$ (RIASL₁₂)

	RIASL ₁₂ Exceedance
	TSRIASL ₁₂ Exceedance

Summary of Results for Chloroform

Sample Type	Sample ID	Measured Concentration ($\mu\text{g}/\text{m}^3$)						
		Oct. 2016	Aug./Sept. 2017	Feb. 2018	Apr. 2018	Feb. 2019	May 2019	Aug. 2019
		E1	E2	E3	E4	E5	E6	E7
Outdoor Air	680-OA-01	<3.9	<0.16	<0.14	<0.16	0.16	<0.16	<0.17
Indoor Air	680-IA-01	<4.1	0.17	0.29	0.21	0.50	0.26	<0.17
	680-IA-02	<3.8	0.27	0.46	0.36	0.65	0.36	0.39
	680-IA-03	<3.8	0.38	0.45	0.40	1	1.1	0.33
	680-IA-04	<3.8	0.64	<0.16	<0.16	<0.15	0.69	0.21
	680-IA-05	--	--	--	--	0.50	3.4	0.31
	680-IA-06	--	--	--	--	1	<0.15	0.30
	680-IA-07	--	--	--	--	3.6	0.60	0.43
	680-IA-08	--	--	--	--	0.51	0.30	<0.16
Sub-Slab Soil Gas	680-SS-01	1,500	1,500	700	940	790	1,100	2,600
	680-SS-02	380	53	120	15	1,100	48	21
	680-SS-03	170	240	120	100	37	15	92
	680-SS-04	2,000	2,000	<250	140	370	<15	1,800
	680-SS-05	--	--	--	--	3,300	1,900	<8,100
	680-SS-06	--	--	--	--	7,000	4,800	8,900
	680-SS-07	--	--	--	--	12	9.6	25
	680-SS-08	--	--	--	--	620	1,000	920

Screening levels for indoor air are $5.2 \mu\text{g}/\text{m}^3$ (RIASL₁₂) and $52 \mu\text{g}/\text{m}^3$ (TRIASL₁₂)
Screening levels for soil-gas are $170 \mu\text{g}/\text{m}^3$ (RIASL₁₂) and $1,700 \mu\text{g}/\text{m}^3$ (TSRIASL₁₂)

Summary of Results for cis-1,2-Dichloroethene (cis-1,2-DCE)

Sample Type	Sample ID	Measured Concentration ($\mu\text{g}/\text{m}^3$)						
		Oct. 2016	Aug./Sept. 2017	Feb. 2018	Apr. 2018	Feb. 2019	May 2019	Aug. 2019
		E1	E2	E3	E4	E5	E6	E7
Outdoor Air	680-OA-01	<3.2	<0.13	0.36	0.30	0.34	<0.13	<0.14
Indoor Air	680-IA-01	<3.3	0.65	3.0	0.91	3.5	1.2	0.19
	680-IA-02	11	6.1	7.8	6.0	5.4	2.8	2.2
	680-IA-03	14	6.9	9.1	5.6	10	8	1.8
	680-IA-04	<3.1	6.1	0.36	0.43	0.46	11	1.1
	680-IA-05	--	--	--	--	23	45	4.6
	680-IA-06	--	--	--	--	12	0.36	0.91
	680-IA-07	--	--	--	--	5.5	3	1.5
	680-IA-08	--	--	--	--	3.5	1.5	0.16
Sub-Slab Soil Gas	680-SS-01	30	18	14	16	11	14	20
	680-SS-02	610	380	160	130	100	730	14
	680-SS-03	13,000	20,000	7,500	7,200	3,900	1,400	11,000
	680-SS-04	17,000	19,000	3,400	1,900	4,600	100	18,000
	680-SS-05	--	--	--	--	380,000	210,000	840,000
	680-SS-06	--	--	--	--	150,000	96,000	170,000
	680-SS-07	--	--	--	--	33	59	30
	680-SS-08	--	--	--	--	12	16	20

Screening levels for indoor air are $24 \mu\text{g}/\text{m}^3$ (RIASL₁₂) and $72 \mu\text{g}/\text{m}^3$ (TSRIASL₁₂)
Screening levels for soil-gas are $820 \mu\text{g}/\text{m}^3$ (RIASL₁₂) and $2,500 \mu\text{g}/\text{m}^3$ (TRIASL₁₂)

	RIASL ₁₂ Exceedance
	TSRIASL ₁₂ Exceedance

Summary of Results for Hexachlorobutadiene (HCBd)

Sample Type	Sample ID	Measured Concentration ($\mu\text{g}/\text{m}^3$)						
		Oct. 2016	Aug./Sept. 2017	Feb. 2018	Apr. 2018	Feb. 2019	May 2019	Aug. 2019
		E1	E2	E3	E4	E5	E6	E7
Outdoor Air	680-OA-01	<34	<8.5	<7.7	<8.7	<7.8	<8.6	<3.8
Indoor Air	680-IA-01	<36	<8.4	<9.4	<8.6	<8.7	<8.6	<3.7
	680-IA-02	<34	<8.3	<8.6	<8.8	<8.7	<9.3	<3.8
	680-IA-03	<34	<8.6	<8.7	<8.9	<8.8	<9.1	<3.8
	680-IA-04	<33	<9.1	<8.6	<9.0	<8.3	<9	<3.6
	680-IA-05	--	--	--	--	<17	<43	<3.8
	680-IA-06	--	--	--	--	<7	<8	<4.2
	680-IA-07	--	--	--	--	<8.5	<18	<3.6
	680-IA-08	--	--	--	--	<8.2	<9.1	<3.6
Sub-Slab Soil Gas	680-SS-01	3,400	2,000	2,100	4,400	1,800	1,200	3,600
	680-SS-02	170	84	52	47	<110	80	<33
	680-SS-03	4,600	9,600	3,200	4,100	430	790	4,200
	680-SS-04	<1,900	<4,300	<2,200	<1,200	<610	<130	<3,100
	680-SS-05	--	--	--	--	<19,000	<16,000	<71,000
	680-SS-06	--	--	--	--	5,900	13,000	18,000
	680-SS-07	--	--	--	--	<34	33	38
	680-SS-08	--	--	--	--	400	540	610

Screening level for indoor air is $5.4 \mu\text{g}/\text{m}^3$ (RIASL₁₂)

Screening level for soil-gas is $180 \mu\text{g}/\text{m}^3$ (RIASL₁₂)

Summary of Results for Tetrachloroethene (PCE)

Sample Type	Sample ID	Measured Concentration ($\mu\text{g}/\text{m}^3$)						
		Oct. 2016	Aug./Sept. 2017	Feb. 2018	Apr. 2018	Feb. 2019	May 2019	Aug. 2019
		E1	E2	E3	E4	E5	E6	E7
Outdoor Air	680-OA-01	<5.4	0.39	4.5	3.0	0.36	0.48	1.2
Indoor Air	680-IA-01	<5.7	3.4	25	8.1	36	14	2.8
	680-IA-02	26	29	67	54	54	30	36
	680-IA-03	30	33	75	49	54	32	24
	680-IA-04	<5.3	54	4.2	5.8	4.2	87	18
	680-IA-05	--	--	--	--	230	440	64
	680-IA-06	--	--	--	--	81	3.5	16
	680-IA-07	--	--	--	--	56	34	26
	680-IA-08	--	--	--	--	36	17	3
Sub-Slab Soil Gas	680-SS-01	2,600	1,800	6,200	1,800	1,300	1,700	2,600
	680-SS-02	1,800	550	470	140	3,800	580	160
	680-SS-03	11,000	17,000	7,700	6,600	3,400	2,300	7,700
	680-SS-04	460,000	760,000	140,000	50,000	130,000	4,800	590,000
	680-SS-05	--	--	--	--	2,800,000	2,700,000	6,400,000
	680-SS-06	--	--	--	--	680,000	580,000	910,000
	680-SS-07	--	--	--	--	100	100	220
	680-SS-08	--	--	--	--	1,600	2,500	2,400

Screening level for indoor air is $82 \mu\text{g}/\text{m}^3$ (RIASL₁₂ and TSRIASL₁₂)

Screening level for soil-gas is $2,700 \mu\text{g}/\text{m}^3$ (RIASL₁₂ and TSRIASL₁₂)

	RIASL ₁₂ Exceedance
	TSRIASL ₁₂ Exceedance

Summary of Results for Trichloroethene (TCE)

Sample Type	Sample ID	Measured Concentration ($\mu\text{g}/\text{m}^3$)						
		Oct. 2016	Aug./Sept. 2017	Feb. 2018	Apr. 2018	Feb. 2019	May 2019	Aug. 2019
		E1	E2	E3	E4	E5	E6	E7
Outdoor Air	680-OA-01	<4.3	<0.17	0.30	0.26	0.17	<0.17	<0.19
Indoor Air	680-IA-01	<4.5	0.57	3.5	1.1	5	1.9	0.38
	680-IA-02	5.0	4.8	8.9	7.6	7.6	4.1	4.6
	680-IA-03	5.7	5.3	11	6.9	8.3	4.9	3.2
	680-IA-04	<4.2	3.8	0.24	0.31	0.28	8.7	1.8
	680-IA-05	--	--	--	--	14	40	5.6
	680-IA-06	--	--	--	--	16	0.53	2.2
	680-IA-07	--	--	--	--	7.2	4.5	3.4
	680-IA-08	--	--	--	--	4.9	2.4	0.39
Sub-Slab Soil Gas	680-SS-01	290	270	140	220	160	220	340
	680-SS-02	220	120	63	38	230	220	22
	680-SS-03	3,500	6,500	2,600	2,400	980	470	2,500
	680-SS-04	18,000	32,000	5,300	2,300	4,800	100	21,000
	680-SS-05	--	--	--	--	250,000	170,000	530,000
	680-SS-06	--	--	--	--	140,000	100,000	170,000
	680-SS-07	--	--	--	--	20	29	48
	680-SS-08	--	--	--	--	290	450	400

Screening levels for indoor air are $4 \mu\text{g}/\text{m}^3$ (RIASL₁₂) and $12 \mu\text{g}/\text{m}^3$ (TSRIASL₁₂)
Screening levels for soil-gas are $130 \mu\text{g}/\text{m}^3$ (RIASL₁₂) and $400 \mu\text{g}/\text{m}^3$ (TSRIASL₁₂)

Summary of Results for Vinyl Chloride

Sample Type	Sample ID	Measured Concentration ($\mu\text{g}/\text{m}^3$)						
		Oct. 2016	Aug./Sept. 2017	Feb. 2018	Apr. 2018	Feb. 2019	May 2019	Aug. 2019
		E1	E2	E3	E4	E5	E6	E7
Outdoor Air	680-OA-01	<2	<0.041	<0.042	<0.042	0.10	<0.041	<0.046
Indoor Air	680-IA-01	<2.1	<0.04	<0.045	<0.041	0.072	<0.041	<0.045
	680-IA-02	<2	<0.04	0.045	<0.042	0.073	<0.044	<0.046
	680-IA-03	<2	0.04	0.048	<0.043	0.095	<0.043	<0.046
	680-IA-04	<2	0.048	<0.041	<0.043	0.071	<0.043	<0.044
	680-IA-05	--	--	--	--	0.19	<0.21	0.048
	680-IA-06	--	--	--	--	0.094	<0.038	<0.05
	680-IA-07	--	--	--	--	0.089	<0.089	<0.044
	680-IA-08	--	--	--	--	0.077	<0.043	<0.043
Sub-Slab Soil Gas	680-SS-01	<14	<8.2	<6.8	<4.1	2.8	6	12
	680-SS-02	<2.2	<2	<2	<2	<6.8	<2.7	<2
	680-SS-03	<42	<20	<20	<20	<9.7	<4.5	<20
	680-SS-04	<110	<260	<130	<69	<37	<7.9	<190
	680-SS-05	--	--	--	--	3,200	<990	<4,200
	680-SS-06	--	--	--	--	390	<180	480
	680-SS-07	--	--	--	--	<2	<1.9	<2.2
	680-SS-08	--	--	--	--	<2.7	10	<8.8

Screening levels for indoor air are $28 \mu\text{g}/\text{m}^3$ (RIASL₁₂) and $280 \mu\text{g}/\text{m}^3$ (TSRIASL₁₂)
Screening levels for soil-gas are $910 \mu\text{g}/\text{m}^3$ (RIASL₁₂) and $9100 \mu\text{g}/\text{m}^3$ (TSRIASL₁₂)

	RIASL ₁₂ Exceedance
	TSRIASL ₁₂ Exceedance

Summary of Results for trans-1,2-Dichloroethene (trans-1,2-DCE)

Sample Type	Sample ID	Measured Concentration ($\mu\text{g}/\text{m}^3$)						
		Oct. 2016	Aug./Sept. 2017	Feb. 2018	Apr. 2018	Feb. 2019	May 2019	Aug. 2019
		E1	E2	E3	E4	E5	E6	E7
Outdoor Air	680-OA-01	<3.2	<0.63	<0.57	<0.65	<0.58	<0.64	<0.71
Indoor Air	680-IA-01	<3.3	<0.63	<0.70	<0.64	<0.65	<0.64	<0.69
	680-IA-02	<3.1	<0.62	<0.64	<0.65	<0.65	<0.69	<0.71
	680-IA-03	<3.1	<0.64	<0.65	<0.66	<0.66	<0.67	<0.71
	680-IA-04	<3.1	<0.67	<0.64	<0.67	<0.62	<0.67	<0.68
	680-IA-05	--	--	--	--	<1.2	<3.2	<0.71
	680-IA-06	--	--	--	--	0.95	<<0.60	<0.78
	680-IA-07	--	--	--	--	<0.63	<1.4	<0.68
	680-IA-08	--	--	--	--	<0.61	<0.67	<0.67
Sub-Slab Soil Gas	680-SS-01	32	32	12	22	13	23	34
	680-SS-02	21	14	5.2	4.4	<11	32	<3
	680-SS-03	400	740	270	360	130	55	370
	680-SS-04	1,300	1,800	400	240	340	<12	1,700
	680-SS-05	--	--	--	--	6,500	2,900	19,000
	680-SS-06	--	--	--	--	8,900	5,400	13,000
	680-SS-07	--	--	--	--	<3.1	3.2	<3.4
	680-SS-08	--	--	--	--	15	20	21

Screening level for indoor air is $790 \mu\text{g}/\text{m}^3$ (RIASL₁₂ and TSRIASL₁₂)Screening level for soil-gas is $26,000 \mu\text{g}/\text{m}^3$ (RIASL₁₂ and TSRIASL₁₂)**Summary of Results for 1,1-Dichloroethene (1,1-DCE)**

Sample Type	Sample ID	Measured Concentration ($\mu\text{g}/\text{m}^3$)						
		Oct. 2016	Aug./Sept. 2017	Feb. 2018	Apr. 2018	Feb. 2019	May 2019	Aug. 2019
		E1	E2	E3	E4	E5	E6	E7
Outdoor Air	680-OA-01	<3.2	<0.063	<0.057	<0.065	0.089	<0.064	<0.071
Indoor Air	680-IA-01	<3.3	<0.063	0.088	<0.064	0.19	0.11	<0.069
	680-IA-02	<3.1	0.15	0.17	0.21	0.26	0.16	0.15
	680-IA-03	<3.1	0.16	0.21	0.19	0.32	0.26	0.11
	680-IA-04	<3.1	0.087	<0.064	<0.067	<0.062	0.14	<0.068
	680-IA-05	--	--	--	--	0.22	0.60	0.10
	680-IA-06	--	--	--	--	0.51	<0.06	0.098
	680-IA-07	--	--	--	--	0.38	0.19	0.11
	680-IA-08	--	--	--	--	0.19	0.15	<0.067
Sub-Slab Soil Gas	680-SS-01	5,100	3,300	460	910	440	1,600	3,400
	680-SS-02	26	9.9	9.1	<3.2	51	35	<3
	680-SS-03	180	290	120	120	40	16	98
	680-SS-04	260	<400	<200	<110	<57	<12	320
	680-SS-05	--	--	--	--	3,700	<1,500	10,000
	680-SS-06	--	--	--	--	5,100	2,300	4,600
	680-SS-07	--	--	--	--	7.4	20	33
	680-SS-08	--	--	--	--	1,200	2,800	3,800

Screening levels for indoor air are $620 \mu\text{g}/\text{m}^3$ (RIASL₁₂) and $1,900 \mu\text{g}/\text{m}^3$ (TSRIASL₁₂)
Screening levels for soil-gas are $20,000 \mu\text{g}/\text{m}^3$ (RIASL₁₂) and $61,000 \mu\text{g}/\text{m}^3$ (TSRIASL₁₂)

	RIASL ₁₂ Exceedance
	TSRIASL ₁₂ Exceedance

Summary of Results for Chlorofluorocarbon (CFC-12)

Sample Type	Sample ID	Measured Concentration ($\mu\text{g}/\text{m}^3$)						
		Oct. 2016	Aug./Sept. 2017	Feb. 2018	Apr. 2018	Feb. 2019	May 2019	Aug. 2019
		E1	E2	E3	E4	E5	E6	E7
Outdoor Air	680-OA-01	<3.9	2.8	2.3	2.2	2.0	2.2	1.9
Indoor Air	680-IA-01	<4.1	2.7	2.4	2.2	2.2	2.2	1.8
	680-IA-02	<3.9	2.8	2.3	2.0	2.2	2.2	1.8
	680-IA-03	<3.9	2.8	2.3	2.0	2.1	2.3	1.8
	680-IA-04	<3.8	3.1	2.3	2.0	2.2	2.2	1.8
	680-IA-05	--	--	--	--	2.0	2.2	1.8
	680-IA-06	--	--	--	--	2.1	2.2	1.8
	680-IA-07	--	--	--	--	2.2	2.2	1.8
	680-IA-08	--	--	--	--	2.1	2.2	1.9
Sub-Slab Soil Gas	680-SS-01	5,600	310	290	99	370	90	100
	680-SS-02	47	<4	8.6	3.9	<13	<5.3	<3.8
	680-SS-03	<81	<38	<40	<38	<19	<8.7	<39
	680-SS-04	230	<500	460	<130	670	<15	<360
	680-SS-05	--	--	--	--	<2,200	<1,900	<8,200
	680-SS-06	--	--	--	--	<500	<350	<490
	680-SS-07	--	--	--	--	<3.9	<3.6	<4.2
	680-SS-08	--	--	--	--	400	160	78

Screening level for indoor air is 1,020 $\mu\text{g}/\text{m}^3$ (RIASL₁₂)

Screening level for soil-gas is 34,000 $\mu\text{g}/\text{m}^3$ (RIASL₁₂)

Summary of Results for 1,1,1-Trichloroethane (1,1,1-TCA)

Sample Type	Sample ID	Measured Concentration ($\mu\text{g}/\text{m}^3$)						
		Oct. 2016	Aug./Sept. 2017	Feb. 2018	Apr. 2018	Feb. 2019	May 2019	Aug. 2019
		E1	E2	E3	E4	E5	E6	E7
Outdoor Air	680-OA-01	<4.3	<0.17	<0.16	<0.18	<0.16	<0.18	<0.20
Indoor Air	680-IA-01	<4.6	<0.17	0.19	<0.18	0.4	<0.18	<0.19
	680-IA-02	<4.3	<0.17	0.50	<0.18	0.6	<0.19	<0.20
	680-IA-03	<4.3	<0.18	<0.18	<0.18	0.4	0.20	<0.20
	680-IA-04	<4.2	1.1	<0.18	<0.18	<0.17	2.3	0.22
	680-IA-05	--	--	--	--	1.9	12	0.56
	680-IA-06	--	--	--	--	1.3	<0.16	<0.21
	680-IA-07	--	--	--	--	8.0	<0.38	<0.19
	680-IA-08	--	--	--	--	0.42	<0.18	<0.18
Sub-Slab Soil Gas	680-SS-01	<30	<18	<15	11	6.9	11	17
	680-SS-02	540	27	180	10	2,900	28	17
	680-SS-03	<89	<42	<44	<42	<21	<9.6	<43
	680-SS-04	2,700	2,500	<280	190	190	<17	2,500
	680-SS-05	--	--	--	--	34,000	18,000	81,000
	680-SS-06	--	--	--	--	3,500	2,000	4,500
	680-SS-07	--	--	--	--	13	4	18
	680-SS-08	--	--	--	--	14	26	24

Screening level for indoor air is 7,000 $\mu\text{g}/\text{m}^3$ (RIASL₁₂ and TSRIASL₁₂)

Screening level for soil-gas is 230,000 $\mu\text{g}/\text{m}^3$ (RIASL₁₂ and TSRIASL₁₂)

	RIASL ₁₂ Exceedance
	TSRIASL ₁₂ Exceedance

Summary of Results for Methylene Chloride

Sample Type	Sample ID	Measured Concentration ($\mu\text{g}/\text{m}^3$)						
		Oct. 2016	Aug./Sept. 2017	Feb. 2018	Apr. 2018	Feb. 2019	May 2019	Aug. 2019
		E1	E2	E3	E4	E5	E6	E7
Outdoor Air	680-OA-01	<28	12	150	6.2	16	20	6.7
Indoor Air	680-IA-01	<14.5	3.3	88	22	19	37	10
	680-IA-02	<13.5	5.2	36	3.9	18	21	6.3
	680-IA-03	<13.5	2.5	14	2.8	16	25	7.7
	680-IA-04	<13.5	3.1	130	50	38	30	10
	680-IA-05	--	--	--	--	27	26	8.6
	680-IA-06	--	--	--	--	20	17	6.4
	680-IA-07	--	--	--	--	18	22	7.6
	680-IA-08	--	--	--	--	19	31	11
Sub-Slab Soil Gas	680-SS-01	<190	<110	<93	56	27	<60	<86
	680-SS-02	<30	<28	<28	<28	<93	<37	<27
	680-SS-03	<570	<110	<280	<270	<130	<61	<280
	680-SS-04	1,000	<1,400	<1,800	<940	<200	<110	<1,000
	680-SS-05	--	--	--	--	<6,100	<5,400	<23,000
	680-SS-06	--	--	--	--	<1,400	<970	<1,400
	680-SS-07	--	--	--	--	<27	28	<29
	680-SS-08	--	--	--	--	<36	<140	<120

Screening levels for indoor air are 1,800 $\mu\text{g}/\text{m}^3$ (RIASL₁₂) and 2,900 $\mu\text{g}/\text{m}^3$ (TSRIASL₁₂)
Screening levels for soil-gas are 61,000 $\mu\text{g}/\text{m}^3$ (RIASL₁₂) and 97,000 $\mu\text{g}/\text{m}^3$ (TSRIASL₁₂)

	RIASL ₁₂ Exceedance
	TSRIASL ₁₂ Exceedance

EVALUATION OF VI DATA TRENDS

Data trends for Building 680 are discussed below for both sub-slab soil gas and indoor air. When data exhibit a narrow range of variability, it is typical practice to express the range as a percentage. When data exhibit a large range of variability, however, it is more useful to express the range in orders of magnitude (i.e., factors of 10). This can be expressed mathematically as the log of the ratio of maximum/minimum values. If the values differ by a factor of 10, the log of the ratio is 1, if the values differ by a factor of 100, the log of the ratio is 2, and so on.

The variability across all locations over all sampling events is the total variability. This encompasses different types of variability, including spatial variability (i.e., how do the results vary from location to location), temporal variability (i.e., how do the results at a given location vary over time), and measurement variability. Measurement variability can be determined by evaluating results of duplicate or collocated samples and includes both sampling variability and analytical variability. The comparison of two data values is typically expressed as a relative percent difference (RPD). The comparison of three or more data values is typically expressed as the % coefficient of variation (CV), which is the standard deviation divided by the mean.

Sub-Slab Soil Gas Data Trends

Spatial Variability of Sub-Slab Soil Gas – The soil gas exhibits over four orders of magnitude of spatial variability. For example, sub-slab soil gas detections of PCE vary from 160 to 6,400,000 $\mu\text{g}/\text{m}^3$ (log of max./min. = 4.6) across the eight locations for E7. During that same sampling event, the range for TCE was 22 to 530,000 $\mu\text{g}/\text{m}^3$ (log of max./min. = 4.4) and the range for cis-1,2-DCE was 14 to 840,000 $\mu\text{g}/\text{m}^3$ (log of max./min. = 4.8).

Temporal Variability of Soil Gas – The soil gas exhibits up to two orders of magnitude of temporal variability. For example, sub-slab soil gas concentrations of PCE vary from 4,800 to 760,000 $\mu\text{g}/\text{m}^3$ at location 680-SS-04 (log max/min = 2.2) across all seven sampling events. At that same location, the range for TCE was 100 to 32,000 $\mu\text{g}/\text{m}^3$ (log max/min = 2.5). Measured values for E6 were atypically low. If this event is not included, the temporal variability was about one order of magnitude for PCE and TCE. The variability for PCE and TCE at other locations was less (e.g., about a factor of three). Similarly, the variability for other analytes was relatively small.

Seasonal Confirmation Sampling Trend Analysis – No formal statistical tests were performed but the sub-slab soil gas data at locations with the highest concentrations do not exhibit any upward or downward trend over the course of the seven sampling events. This is illustrated in the graph below, which shows results for several locations with relatively high concentrations for the three analytes detected at the highest concentrations. Note that the y-axis is a log scale.

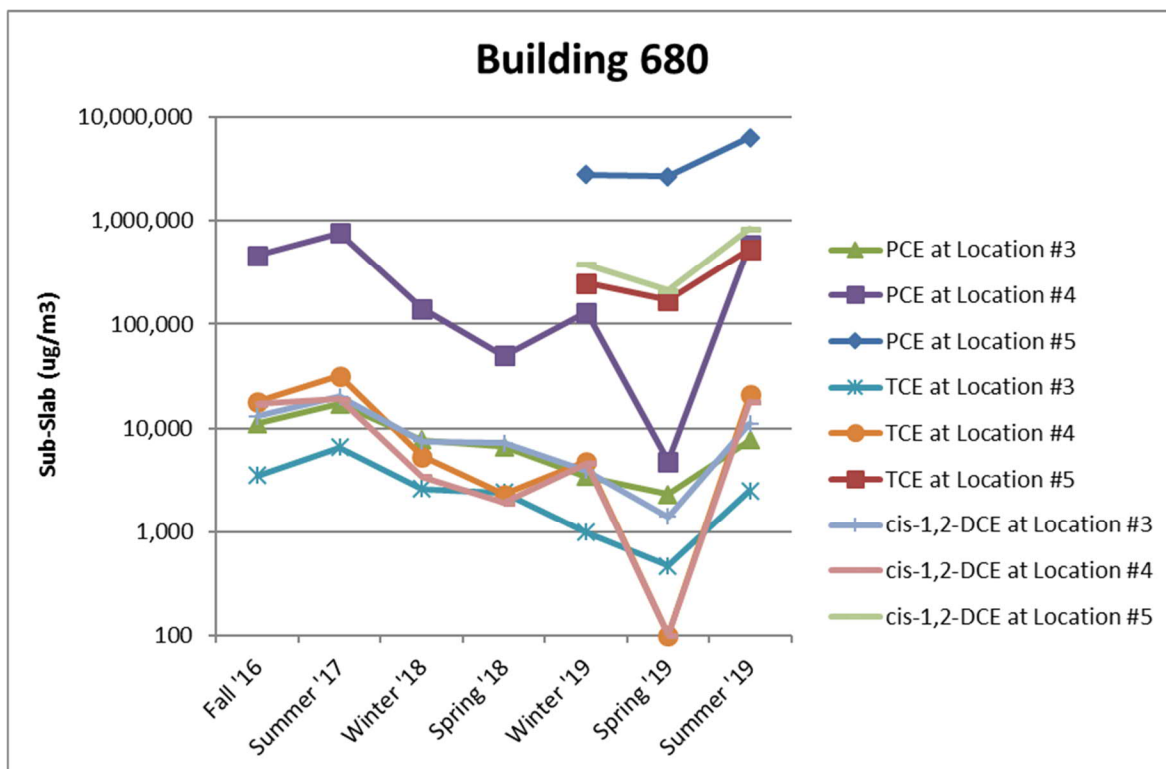

For analytes with lower sub-slab soil gas concentrations, the values also tended to be stable over time. This is illustrated in the figure below. Data for various analytes at location 680-SS-01 are shown (i.e., the location where the highest concentrations of that analyte generally were detected during the sampling events). Note that the y-axis is still a log scale, but for a lower range of values.

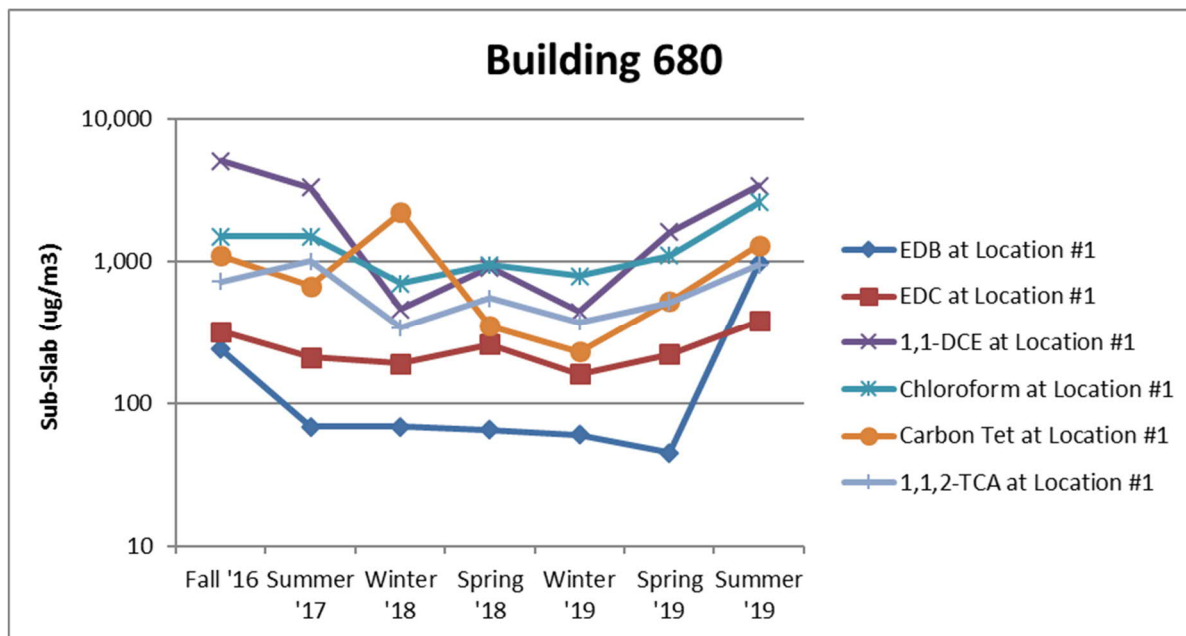

The data set was examined to see what the potential consequences would have been had only a single sampling event been performed. For the analytes present at the highest concentrations in the sub-slab soil gas (i.e., PCE, TCE, and cis-1,2-DCE), the maximum sub-slab soil gas concentration was obtained during E2 (summer) or E7 (summer). For PCE at location 680-SS-04, the value increased from 460,000 during E1 to 760,000 during E2. If only the first sampling event had been performed, a negative bias of 65% would have been introduced (i.e., the PCE value for E2 was 65% higher than the PCE value for E1).

Indoor Air Data Trends

Spatial Variability of Indoor Air – The indoor air exhibits about two orders of magnitude of spatial variability. For example, PCE was detected in all eight indoor air samples and varied from 3.5 to 440 $\mu\text{g}/\text{m}^3$ during E6 (log max./min. = 2.1). PCE had about the same amount of spatial variability during E5 and E7. During E6, TCE was detected in all eight indoor air samples and varied from 0.53 to 40 $\mu\text{g}/\text{m}^3$ (log max./min. = 1.9). TCE had less spatial variability during the other sampling events.

Temporal Variability of Indoor Air – The detected values for PCE and TCE exhibit temporal variability of about one order of magnitude over time. For example, PCE was detected during six of the seven sampling events at locations 680-IA-01 and 680-IA-04 and the values ranged from 2.8 to 36 $\mu\text{g}/\text{m}^3$ at location 680-IA-01 (log max./min. = 1.1) and from 4.2 to 87 $\mu\text{g}/\text{m}^3$ at location 680-IA-04 (log max./min. = 1.3). For TCE, the variability over time was similar to that for PCE. For example, TCE was detected during six of the seven sampling events at location 680-IA-04, with values ranging from 0.24 to 8.7 $\mu\text{g}/\text{m}^3$ (log max./min. = 1.6).

Additional Analyses

Comparison of Sub-Slab Soil Gas and Indoor Air Data Sets – As expected, the sub-slab soil gas data exhibit greater spatial variability than the indoor air data set. The sub-slab soil gas data had somewhat greater temporal variability than the indoor air data, which is contrary to expectations. This suggests that any indoor emissions of the AOIs do not vary greatly over time if they are in regular use in the building.

Seasonal Effects – The data do not support the hypothesis that wintertime will have higher indoor air impacts. The highest sub-slab soil gas concentrations were measured in August (summer), but the highest indoor air concentrations for PCE and TCE were measured in May (spring). The data indicate that wintertime “stack effects” across the slab are not significant compared with other seasons of the year.

Comparison of Attenuation Factors by Event – Attenuation factors were calculated based on maximum values and are shown in Table 680-1. The values in Table 1 have not been corrected for any contribution from outdoor air.

Table 1. Calculated Attenuation Factors

	E1	E2	E3	E4	E5	E6	E7
Evaluation Based on Maximum Detected Value							
1,1-DCE	NC	4.8E-05	4.6E-04	2.3E-04	1.0E-04	2.1E-04	1.5E-05
PCE	6.5E-05	7.1E-05	5.4E-04	1.1E-03	8.2E-05	1.6E-04	1.0E-05
TCE	3.2E-04	1.7E-04	2.1E-03	3.2E-03	6.4E-05	2.4E-04	1.1E-05
cis-1,2-DCE	8.2E-04	3.4E-04	1.2E-03	8.3E-04	6.1E-05	2.1E-04	5.5E-06
HCBD	<7.8E-03	<9.5E-04	<2.9E-03	<2.0E-03	<2.9E-03	<3.3E-03	<2.3E-04
EDC	NC	9.5E-04	7.4E-04	<5.4E-04	1.1E-03	<3.0E-03	<4.2E-04
trans-1,2-DCE	NC	<3.7E-04	<1.8E-03	<1.9E-03	1.1E-04	<5.9E-04	<4.1E-05
Chloroform	NC	3.2E-04	6.6E-04	4.3E-04	5.1E-04	7.1E-04	4.8E-05
1,1,1-TCA	NC	4.4E-04	2.8E-03	<9.5E-04	2.4E-04	6.7E-04	6.9E-06
Carbon Tetrachloride	NC	6.8E-04	2.3E-04	1.3E-03	3.4E-03	9.3E-04	3.5E-04
1,1,2-TCA	NC	<1.8E-04	<5.6E-04	<3.3E-04	<9.2E-04	<1.7E-03	<2.1E-03

NC - Not calculated due to elevated detection limits for indoor air.

The best conservative estimates of a building-specific attenuation factor for Building 680 are the values for 1,1-DCE for each sampling event. This analyte generally has the smallest attenuation factor for each sampling event (i.e., the least bias due to contributions from any indoor or outdoor sources). 1,1-DCE is the only analyte detected at relatively high concentrations in the subsurface with all of what was detected indoors likely attributable to VI (i.e., the bias introduced by indoor emission sources and/or outdoor air is believed to be negligible). During E1, 1,1-DCE and several other analytes were ND but with relatively high RLs. For E1, the best estimate of a building-specific attenuation factor is PCE.

Temporal Variability in Attenuation Factor – As shown in Table 1, there was slightly more than one order of magnitude in temporal variability in the calculated attenuation factors observed in the data set, with E3 having the least attenuation and E7 have the greatest attenuation. The E7 sampling event occurred after interim actions were implemented to seal the joint seams that were identified during further investigation activities conducted in March 2019. As illustrated in the figure below that plots the inverse attenuation factor for various analytes for each sampling event, interim actions completed to date appear to have reduced levels of VI in Building 680. Taller columns denote greater attenuation (i.e. less VI), so the height of the last sampling event (E7) versus the earlier sampling events provides an indication of the effectiveness of interim actions.

Assuming VI was the only source of these analytes in indoor air, all of the columns for each event would be expected to have about the same height. Shorter columns potentially represent greater contribution from indoor workplace chemical use and/or outdoor sources for a given analyte.

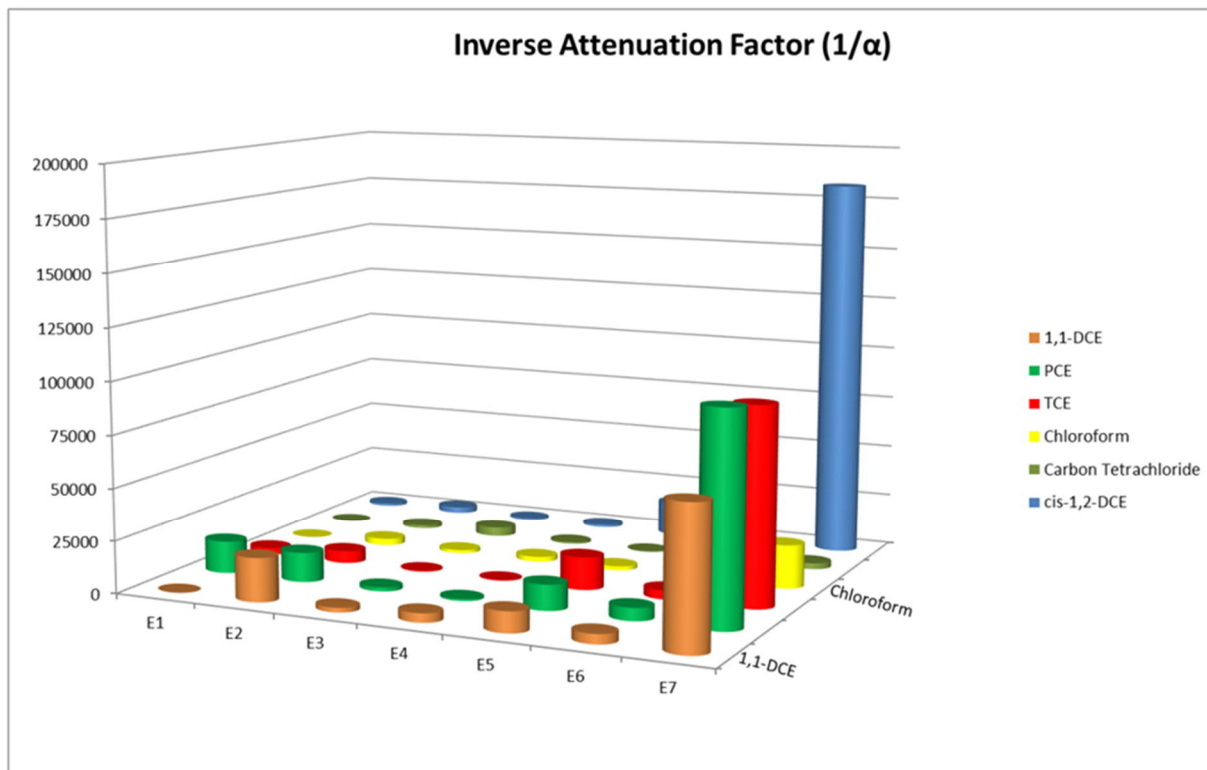

NON-DETECT EVALUATION

There were 11 ND analytes in indoor air with RLs that exceeded the indoor air screening level during E1. Of those, only three analytes continued to have ND exceedances in E2 - E6: 1,2,4-TCB, EDB and HCBd. In E4, 1,2,4-TCB ND RLs were all below the indoor air screening levels, but they were above in E5, E6, and E7. EDB and HCBd were already identified as AOIs due to detections in sub-slab soil gas that exceed the screening levels; however, 1,2,4-TCB has been added to that list based on ND sub-slab soil gas values in the 2019 sampling events. For all three analytes, estimated indoor air concentrations are provided below.

There have been no detections of HCBd, EDB, of 1,2,4-TCB in indoor air, but the ND RLs often exceed the draft project-specific RIASL₁₂ for HCBd (5.4 µg/m³), for EDB (0.2 µg/m³), and for 1,2,4-TCB (2.1 µg/m³). As shown in Tables 680-2, 680-3, and 680-4, using the selected building-specific attenuation factor, indoor air values due to VI were estimated based on the maximum detected sub-slab soil gas concentration for each event.

Table 680-2. Evaluation of Estimated Indoor Air Concentrations for HCB

	E1	E2	E3	E4	E5	E6	E7
Evaluation Based on Maximum Detected Value							
Maximum Detection of HCB in Sub-Slab Soil Gas ($\mu\text{g}/\text{m}^3$)	4,600	9,600	3,200	4,400	5,900	13,000	18,000
Building-specific attenuation factor	6.5E-05	4.8E-05	4.6E-04	2.3E-04	1.0E-04	2.1E-04	1.5E-05
Predicted Indoor Air Impacts ($\mu\text{g}/\text{m}^3$) ^a	0.30	0.46	1.5	1.0	0.59	2.7	0.27
Exceedance of Screening Level of 5.4 $\mu\text{g}/\text{m}^3$?	No	No	No	No	No	No	No
Evaluation Based on Maximum Detection Limit							
Maximum Detection Limit of HCB in Sub-Slab Soil Gas ($\mu\text{g}/\text{m}^3$)	<1,900	<4,300	<2,200	<1,200	<19,000	<16,000	<71,000
Building-specific attenuation factor	6.5E-05	4.8E-05	4.6E-04	2.3E-04	1.0E-04	2.1E-04	1.5E-05
Predicted Indoor Air Impacts ($\mu\text{g}/\text{m}^3$) ^a	<0.12	<0.21	<1.0	<0.28	<1.9	<3.4	<1.1
Exceedance of Screening Level of 5.4 $\mu\text{g}/\text{m}^3$?	No	No	No	No	No	No	No

^a Based on the selected building-specific attenuation factor for each sampling event.

Table 680-3. Evaluation of Estimated Indoor Air Concentrations for EDB

	E1	E2	E3	E4	E5	E6	E7
Evaluation Based on Maximum Detected Value							
Maximum Detection of EDB in Sub-Slab Soil Gas ($\mu\text{g}/\text{m}^3$)	240	68	68	65	60	45	970
Building-specific attenuation factor	6.5E-05	4.8E-05	4.6E-04	2.3E-04	1.0E-04	2.1E-04	1.5E-05
Predicted Indoor Air Impacts ($\mu\text{g}/\text{m}^3$) ^a	0.02	0.003	0.03	0.01	0.01	0.01	0.01
Exceedance of Screening Level of 0.2 $\mu\text{g}/\text{m}^3$?	No	No	No	No	No	No	No
Evaluation Based on Maximum Detection Limit							
Maximum Detection Limit of EDB in Sub-Slab Soil Gas ($\mu\text{g}/\text{m}^3$)	<340	<770	<400	<210	<3,400	<3,000	<13,000
Building-specific attenuation factor	6.5E-05	4.8E-05	4.6E-04	2.3E-04	1.0E-04	2.1E-04	1.5E-05
Predicted Indoor Air Impacts ($\mu\text{g}/\text{m}^3$) ^a	<0.02	<0.04	<0.18	<0.05	<0.34	<0.63	<0.20
Exceedance of Screening Level of 0.2 $\mu\text{g}/\text{m}^3$?	No	No	No	No	Possibly	Possibly	No

^a Based on the selected building-specific attenuation factor for each sampling event.

Table 680-4. Evaluation of Estimated Indoor Air Concentrations for 1,2,4-TCB

	E1	E2	E3	E4	E5	E6	E7
Evaluation Based on Maximum Detected Value							
Maximum Detection of 1,2,4-TCB in Sub-Slab Soil Gas ($\mu\text{g}/\text{m}^3$)	n/a	n/a	n/a	n/a	n/a	n/a	n/a
Building-specific attenuation factor	6.5E-05	4.8E-05	4.6E-04	2.3E-04	1.0E-04	2.1E-04	1.5E-05
Predicted Indoor Air Impacts ($\mu\text{g}/\text{m}^3$) ^a							
Exceedance of Screening Level of 2.1 $\mu\text{g}/\text{m}^3$?	No	No	No	No	No	No	No
Evaluation Based on Maximum Detection Limit							
Maximum Detection Limit of 1,2,4-TCB in Sub-Slab Soil Gas ($\mu\text{g}/\text{m}^3$)	<1,300	<3,000	<1,500	<800	<13,000	<12,000	<49,000
Building-specific attenuation factor	6.5E-05	4.8E-05	4.6E-04	2.3E-04	1.0E-04	2.1E-04	1.5E-05
Predicted Indoor Air Impacts ($\mu\text{g}/\text{m}^3$) ^a	<0.08	<0.14	<0.69	<0.18	1.3	2.5	0.74
Exceedance of Screening Level of 2.1 $\mu\text{g}/\text{m}^3$?	No	No	No	No	No	Possibly	No

^a Based on the selected building-specific attenuation factor for each sampling event.

As shown in Tables 680-2, 680-3 and 680-4, the ND evaluation demonstrates that the estimated indoor air concentrations for HCBd, EDB, and 1,2,4-TCB attributable to VI are below their respective draft project-specific RIASL₁₂ for all seven sampling events based on the maximum detected values and, for EDB, based on the detection limits for certain sub-slab soil gas samples. A summary of all VI data trends and findings is presented in Table 5.

Table 680-5. Summary of Findings of Seasonal Confirmation Sampling

Topic	Finding	Details
Spatial Variability of Sub-Slab Soil Gas	Four orders of magnitude or less	PCE during E7 ranged from 160 to 6,400,000 $\mu\text{g}/\text{m}^3$, log max./min. = 4.6 TCE during E7 ranged from 22 to 530,000 $\mu\text{g}/\text{m}^3$, log max./min. = 4.4 For other sampling events involving eight locations, log max./min. generally were similar
Temporal Variability of Sub-Slab Soil Gas	Two orders of magnitude	PCE at location 680-SS-04 ranged from 4,800 to 760,000 $\mu\text{g}/\text{m}^3$, log max./min. = 2.2 Variability for other analytes was similar
Seasonal Trend Analysis	Seasonal sampling is appropriate	No observed seasonal dependence and no upward or downward trend in concentration
Spatial Variability of Indoor Air	Two orders of magnitude or less	PCE during E6 ranged from 3.5 to 440 $\mu\text{g}/\text{m}^3$, log max./min. = 2.1
Temporal Variability of Indoor Air	One order of magnitude	PCE at location 680-SS-04 ranged from 4.2 to 87 $\mu\text{g}/\text{m}^3$, log max./min. = 1.3
Comparison of Sub-Slab Soil Gas vs. Indoor Air	Data show the expected trends for spatial variability. Less temporal variability in indoor air than expected.	Spatial variability: sub-slab soil gas greater than indoor air Temporal variability: sub-slab soil gas greater than indoor air
Best Estimate of Attenuation Factor	Varies from event to event	Best estimates for attenuation factors are based on 1,1-DCE and PCE data. Values vary from a minimum of 1.6E-05 and a maximum of 4.6E-04
Temporal Variability in Attenuation Factor	No definitive trend in seasonal attenuation. Prior to mitigation steps, greatest attenuation occurred during E2 (summer) and E5 (winter)	All calculated attenuation factors fall within two orders of magnitude Summertime sampling event (E7) had highest sub-slab concentrations of TCE and PCE, but springtime sampling event (E6) had highest indoor air concentrations of PCE and TCE.
Overall Summary	Significant decrease in any VI impacts after mitigation steps performed.	Post-mitigation attenuation factor of approximately 1E-05

SUMMARY AND PATH FORWARD

Building 680 is confirmed as a VI Path Forward Group 4B building. Further investigation activities were conducted with a mobile GC in March and May 2019 and reported in the June 2019 Summary of Investigative Findings (see Appendix C).

During these activities, potential workplace indoor sources were investigated with no significant findings. During baseline sample collection, results in the shop (680-xx-05) and storage room/utilities area (680-xx-06) had the highest results. Drains identified and investigated in those areas indicated no significant impacts. The elevator shaft was also investigated and eliminated as a preferential pathway. Further investigation ultimately led to the identification of joint seams around the perimeter in both the shop and storage room/utilities area as a source of VI.

Dow implemented an interim action to seal the joint seams and this activity was completed on April 30, 2019. The field mobile GC team performed a follow-up sampling activity in May 2019. As communicated in the July 2019 Corrective Action status meeting, samples were collected near the sealed joint seams (680-05, 680-06, and 680-11) and results indicated that concentrations decreased but not as much as expected. Based on these results, although sealing the joint seams has reduced the levels of VI, further

actions are warranted. Portions of the building floor slab in the areas impacted by VI should be sealed (Retro-Coat), potentially in conjunction with other mitigation steps. A quarterly interim monitoring plan will be implemented for Building 680 until mitigation steps have addressed the issue and is discussed further below.

Building-Specific Interim Monitoring Plan

Dow will implement a quarterly interim monitoring plan at Building 680 until a revised program or more permanent corrective action plan is developed for the site. Indoor air and sub-slab soil gas will be monitored at all existing sampling locations, with the exception of 680-xx-07. Sample location 680-xx-07 was eliminated due to consistent sub-slab soil gas results below screening levels. Monitoring will be performed for 13 analytes: 1,1,2-TCA, 1,1-DCA, EDB, EDC, 1,2-DCP, carbon tetrachloride, chloroform, cis-1,2-DCE, HCB, PCE, trans-1,2-DCA, TCE, and vinyl chloride. An outdoor air sample will also be collected at the time of each monitoring event. Interim monitoring will be performed quarterly until mitigation is complete and a new LTM plan has been implemented.

Monitoring will begin in the spring of 2020. Email notifications were provided to EGLE in April, July, and October 2019. High level email summary updates will continue to be provided to EGLE as data becomes available and evaluation is performed. Updates will be provided to EGLE in the monthly Corrective Action meetings. Results from each sampling event will be reported in the annual CAIP. Dow may propose changes to the frequency or other aspects of these interim actions based on an evaluation of the data, changes in building use or implementation of other interim response actions (IRAs) to address the potential VI pathway.

Figure 680-1

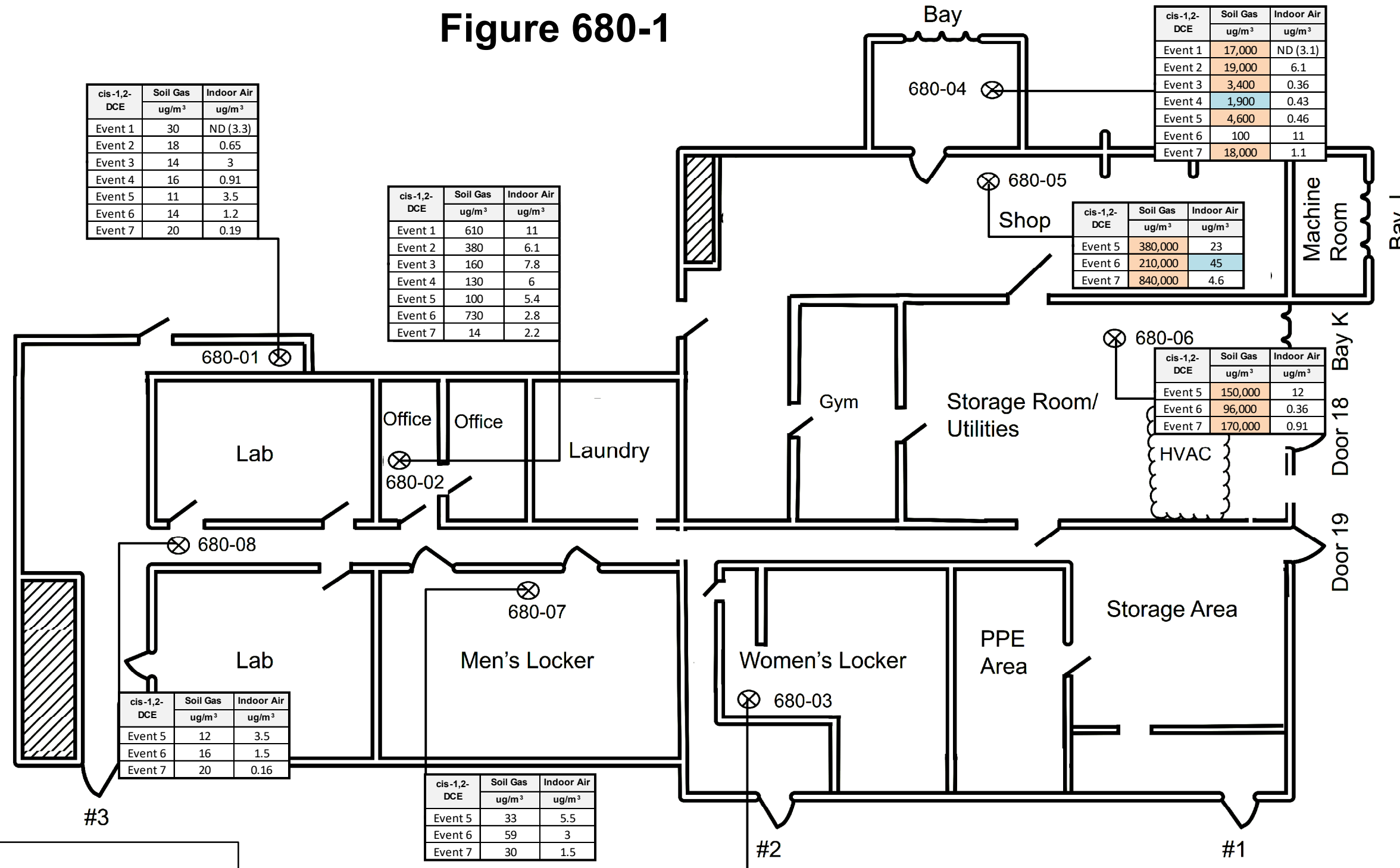

cis-1,2-DCE	Soil Gas ug/m ³	Indoor Air ug/m ³
Event 1	30	ND (3.3)
Event 2	18	0.65
Event 3	14	3
Event 4	16	0.91
Event 5	11	3.5
Event 6	14	1.2
Event 7	20	0.19

cis-1,2-DCE	Soil Gas ug/m ³	Indoor Air ug/m ³
Event 1	610	11
Event 2	380	6.1
Event 3	160	7.8
Event 4	130	6
Event 5	100	5.4
Event 6	730	2.8
Event 7	14	2.2

cis-1,2-DCE	Soil Gas ug/m ³	Indoor Air ug/m ³
Event 5	380,000	23
Event 6	210,000	45
Event 7	840,000	4.6

cis-1,2-DCE	Soil Gas ug/m ³	Indoor Air ug/m ³
Event 1	17,000	ND (3.1)
Event 2	19,000	6.1
Event 3	3,400	0.36
Event 4	1,900	0.43
Event 5	4,600	0.46
Event 6	100	11
Event 7	18,000	1.1

cis-1,2-DCE	Soil Gas ug/m ³	Indoor Air ug/m ³
Event 5	150,000	12
Event 6	96,000	0.36
Event 7	170,000	0.91

cis-1,2-DCE	Soil Gas ug/m ³	Indoor Air ug/m ³
Event 5	12	3.5
Event 6	16	1.5
Event 7	20	0.16

cis-1,2-DCE	Soil Gas ug/m ³	Indoor Air ug/m ³
Event 5	33	5.5
Event 6	59	3
Event 7	30	1.5

cis-1,2-DCE	Soil Gas ug/m ³	Indoor Air ug/m ³
Event 1	13,000	14
Event 2	20,000	6.9
Event 3	7,500	9.1
Event 4	7,200	5.6
Event 5	3,900	10
Event 6	1,400	8
Event 7	11,000	1.8

Legend

⊗ 680-## Sub-slab/Indoor Air Location

- Exceeds RIASL₁₂ Only
- Exceeds TSRIASL₁₂
- Exceeds Dow OEL

Media	COC	RIASL ₁₂	TSRIASL ₁₂	OEL
Soil Gas	cis-1,2-DCE	820	2,500	--
Indoor Air	cis-1,2-DCE	24	72	794,000

Notes:

- All units ug/m³
- Initial Sampling Event (1) = October 2017
- Seasonal Confirmation Sampling Event 2 = March 2018
- Seasonal Confirmation Sampling Event 3 = August 2018
- Seasonal Confirmation Sampling Event 4 = April 2018
- Seasonal Confirmation Sampling Event 5 = February 2019
- Seasonal Confirmation Sampling Event 6 = April 2019
- Seasonal Confirmation Sampling Event 7 = August 2019
- Outdoor air sample was collected from rooftop immediately west of doorway used to access rooftop

cis-1,2-DCE	Outdoor Air Sample Results ug/m ³
Event 1	ND (3.2)
Event 2	ND (0.13)
Event 3	0.36
Event 4	0.3
Event 5	0.34
Event 6	ND (0.13)
Event 7	ND (0.14)

Sub-slab Soil Gas and Indoor Air Results for cis-1,2-Dichloroethene Zone 1 Sampling Events 1 - 7 Building 680



Figure 680-2

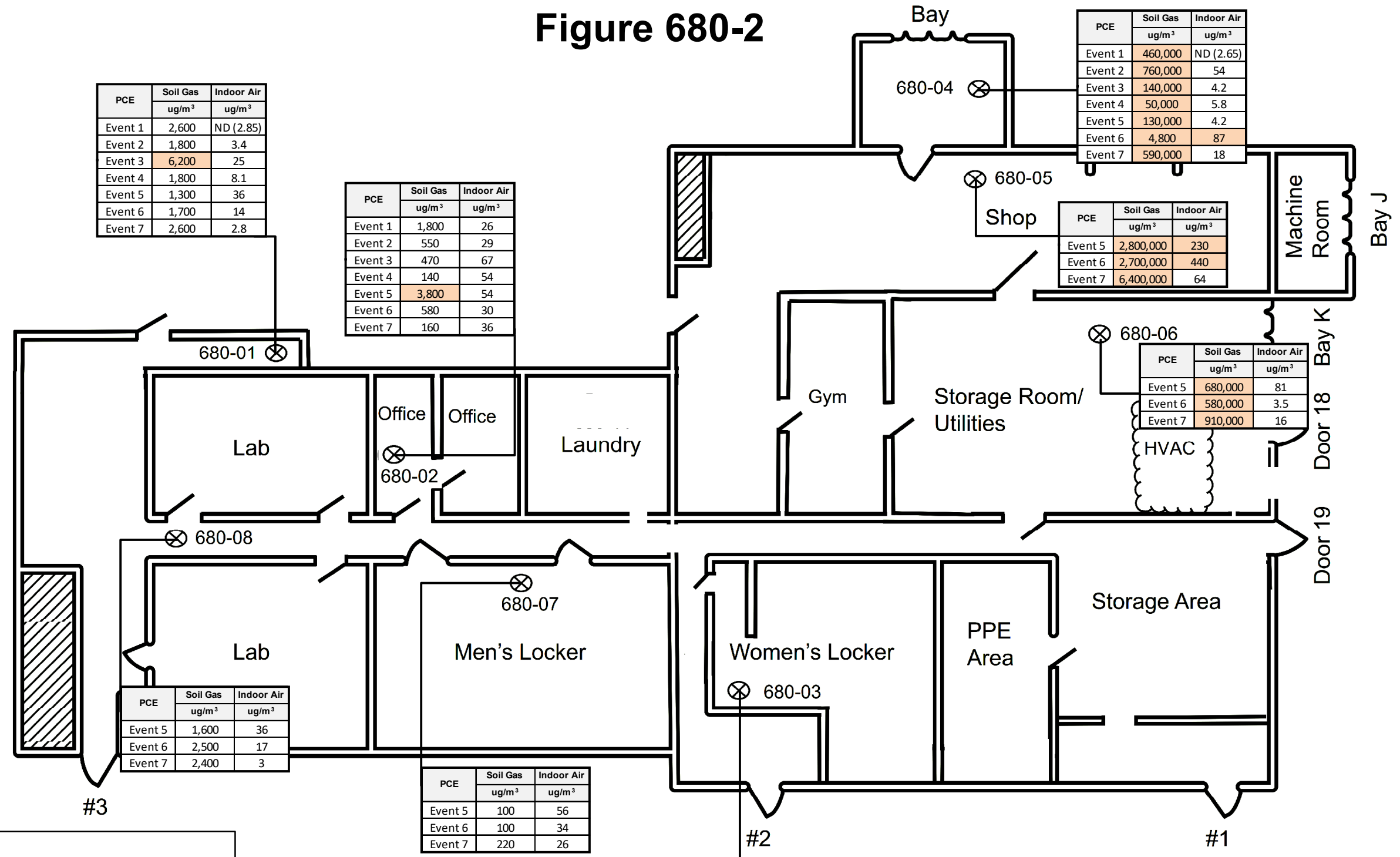

PCE	Soil Gas ug/m ³	Indoor Air ug/m ³
Event 1	2,600	ND (2.85)
Event 2	1,800	3.4
Event 3	6,200	25
Event 4	1,800	8.1
Event 5	1,300	36
Event 6	1,700	14
Event 7	2,600	2.8

PCE	Soil Gas ug/m ³	Indoor Air ug/m ³
Event 1	1,800	26
Event 2	550	29
Event 3	470	67
Event 4	140	54
Event 5	3,800	54
Event 6	580	30
Event 7	160	36

PCE	Soil Gas	Indoor Air
	ug/m ³	ug/m ³
Event 1	460,000	ND (2.65)
Event 2	760,000	54
Event 3	140,000	4.2
Event 4	50,000	5.8
Event 5	130,000	4.2
Event 6	4,800	87
Event 7	590,000	18

PCE	Soil Gas ug/m ³	Indoor Air ug/m ³
Event 5	2,800,000	230
Event 6	2,700,000	440
Event 7	6,400,000	64

PCE	Soil Gas ug/m ³	Indoor Air ug/m ³
Event 5	680,000	81
Event 6	580,000	3.5
Event 7	910,000	16

PCE	Soil Gas ug/m ³	Indoor Air ug/m ³
Event 5	1,600	36
Event 6	2,500	17
Event 7	2,400	3

PCE	Soil Gas ug/m ³	Indoor Air ug/m ³
Event 5	100	56
Event 6	100	34
Event 7	220	26

PCE	Soil Gas ug/m ³	Indoor Air ug/m ³
Event 1	11,000	30
Event 2	17,000	33
Event 3	7,700	75
Event 4	6,600	49
Event 5	3,400	54
Event 6	2,300	32
Event 7	7,700	24

Legend

- 680-## Sub-slab/Indoor Air Location
- Exceeds RIASL₁₂ Only
- Exceeds TSRIASL₁₂
- Exceeds Dow OEL

Media	COC	RIASL ₁₂	TSRIASL ₁₂	OEL
Soil Gas	PCE	2,700	2,700	--
Indoor Air	PCE	82	82	67,800

Notes:

- All units ug/m³
- Initial Sampling Event (1) = October 2017
- Seasonal Confirmation Sampling Event 2 = March 2018
- Seasonal Confirmation Sampling Event 3 = August 2018
- Seasonal Confirmation Sampling Event 4 = April 2018
- Seasonal Confirmation Sampling Event 5 = February 2019
- Seasonal Confirmation Sampling Event 6 = April 2019
- Seasonal Confirmation Sampling Event 7 = August 2019
- Outdoor air sample was collected from rooftop immediately west of doorway used to access rooftop

PCE	Outdoor Air Sample Results
	ug/m ³
Event 1	ND (2.7)
Event 2	0.39
Event 3	4.5
Event 4	3
Event 5	0.36
Event 6	0.48
Event 7	1.2

Sub-slab Soil Gas and Indoor Air Results for Tetrachloroethene Zone 1 Sampling Events 1 - 7 Building 680



Figure 680-3

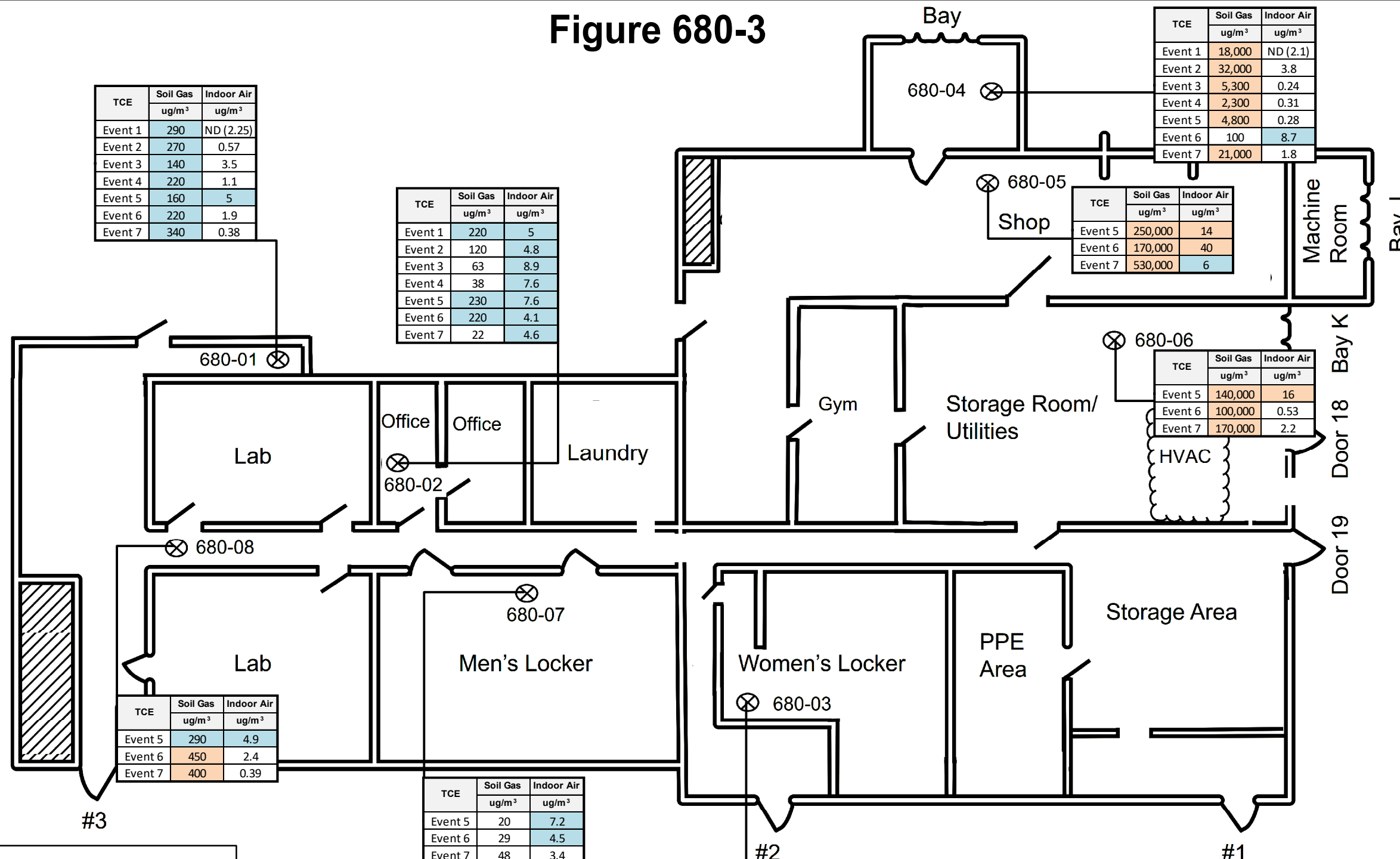

TCE	Soil Gas ug/m ³	Indoor Air ug/m ³
Event 1	290	ND (2.25)
Event 2	270	0.57
Event 3	140	3.5
Event 4	220	1.1
Event 5	160	5
Event 6	220	1.9
Event 7	340	0.38

TCE	Soil Gas ug/m ³	Indoor Air ug/m ³
Event 1	220	5
Event 2	120	4.8
Event 3	63	8.9
Event 4	38	7.6
Event 5	230	7.6
Event 6	220	4.1
Event 7	22	4.6

TCE	Soil Gas ug/m ³	Indoor Air ug/m ³
Event 1	18,000	ND (2.1)
Event 2	32,000	3.8
Event 3	5,300	0.24
Event 4	2,300	0.31
Event 5	4,800	0.28
Event 6	100	8.7
Event 7	21,000	1.8

TCE	Soil Gas ug/m ³	Indoor Air ug/m ³
Event 5	250,000	14
Event 6	170,000	40
Event 7	530,000	6

TCE	Soil Gas ug/m ³	Indoor Air ug/m ³
Event 5	140,000	16
Event 6	100,000	0.53
Event 7	170,000	2.2

TCE	Soil Gas ug/m ³	Indoor Air ug/m ³
Event 5	290	4.9
Event 6	450	2.4
Event 7	400	0.39

TCE	Soil Gas ug/m ³	Indoor Air ug/m ³
Event 5	20	7.2
Event 6	29	4.5
Event 7	48	3.4

TCE	Soil Gas ug/m ³	Indoor Air ug/m ³
Event 1	3,500	5.7
Event 2	6,500	5.3
Event 3	2,600	11
Event 4	2,400	6.9
Event 5	980	8.3
Event 6	470	4.9
Event 7	2500	3.2

Notes:
 All units ug/m3
 Initial Sampling Event (1) = October 2017
 Seasonal Confirmation Sampling Event 2 = March 2018
 Seasonal Confirmation Sampling Event 3 = August 2018
 Seasonal Confirmation Sampling Event 4 = April 2018
 Seasonal Confirmation Sampling Event 5 = February 2019
 Seasonal Confirmation Sampling Event 6 = April 2019
 Seasonal Confirmation Sampling Event 7 = August 2019
 Outdoor air sample was collected from rooftop immediately west of doorway used to access rooftop

TCE	Outdoor Air Sample ug/m ³
Event 1	ND (4.3)
Event 2	ND (0.17)
Event 3	0.3
Event 4	0.26
Event 5	0.17
Event 6	ND (0.17)
Event 7	ND (0.19)

Legend

⊗ 680-## Sub-slab/Indoor Air Location

Exceeds RIASL₁₂ Only

Exceeds TSRIASL₁₂

Exceeds Dow OEL

Media	COC	RIASL ₁₂	TSRIASL ₁₂	OEL
Soil Gas	TCE	130	400	--
Indoor Air	TCE	4	12	26,850

Sub-slab Soil Gas and Indoor Air Results for Trichloroethene Zone 1 Sampling Events 1 - 7 Building 680

5.2.5 Building 838 Interim Monitoring Results Summary

Building 838 is a Category 2 building located within the southwest portion of the facility designated as Zone 1. It is known as the Sulfonamides Shop and contains office space, a shop, storage room, locker room, and a lunch room. Building 838 is a Group 2 building that completed seasonal confirmation sampling in April 2018. A full evaluation and trend analysis was provided in the 2018 CAIP. All indoor air analytes were detected below screening levels during each of the seasonal confirmation sampling events. The sub-slab soil gas AOIs are PCE, TCE, and HCBd due to exceedances of the draft project-specific RIASL₁₂. PCE and TCE also exceeded the TSRIASL₁₂ in sub-slab soil gas.

Based on the evaluation of the four seasonal confirmation sampling events, the VI pathway is insignificant for Building 838 and the sub-slab soil gas results exhibited relatively stable concentrations and no evidence of increasing over time. Sufficient information exists to make a human exposure under control EI determination. However, while currently there is no evidence of potential VI, for future use, LTM was warranted and the building-specific Interim Monitoring Plan was implemented.

Indoor air is monitored at location 838-IA-02. This location was selected for continued monitoring since it demonstrated the highest sub-slab soil gas results. Monitoring is performed for PCE, TCE, and HCBd. Interim monitoring is performed semi-annually and the initial event was conducted in August 2019. The indoor air results are shown below.

Indoor Air Analyte	Result Value (µg/m ³)	Reporting Limit (µg/m ³)	EGLE Project-Specific RIASL ₁₂ (µg/m ³)	NONRES TSRIASL ₁₂ (µg/m ³)	Dow IH OEL (8-hour Time Weighted Average) (µg/m ³)
Hexachlorobutadiene	ND	3.6	5.4	NA	213
Tetrachloroethene	5.2	--	82	82	67,800
Trichloroethene	0.84	--	4	12	26,850

As shown on the table above, all indoor air results from the Summer 2019 IM event were below screening levels or ND with a RL below the indoor air RIASL₁₂. The analytical data is presented in Appendix A. Field sampling forms are provided in Appendix B. The next IM event is scheduled for Winter 2019/2020. Semi-annual interim monitoring will continue in the summer and winter of 2020.

5.2.6 Vapor Intrusion Evaluation for Building 1098

Building 1098 is a Category 2 building and is located within the southeast portion of the facility designated as Zone 1 (Figure 5.2.6-1). It is known as the Environmental Operations (EVO) Maintenance Shop and it is a small single-story building with an open-air storage loft, and it contains a maintenance shop and two offices.

Building 1098 was initially evaluated in the 2017 CAIP and it was concluded that the VI pathway was an insignificant exposure pathway based on current use. Building 1098 was placed into VI Path Forward Building Group 1 and no further VI evaluation was warranted at that time. The results from the initial sampling event were then rescreened in the August 2018 Rescreen. All indoor air analytes were less than screening levels; however, based on exceedances in sub-slab soil gas, Building 1098 was moved into VI Path Forward Building Group 2. Group 2 is a designation for buildings that have sub-slab soil gas AOIs; however, indoor air results are less than screening levels. These buildings are placed into seasonal confirmation sampling to assess potential seasonal variation.

The results of the initial sampling event (E1) were presented in Section 5.1.7 of the 2018 CAIP. Since that time, two additional seasonal events (E2 & E3) have been completed, with a fourth and final event (E4) scheduled for Winter 2019/2020. The results of all completed events are included in this evaluation.

Building 1098	
Initial Sampling Event	Completed
E1	October 2016 (Fall)
Seasonal Sampling Event	Completed
E2	May 2019 (Spring)
E3	August 2019 (Summer)
E4	Scheduled - Winter 2019/2020

No indoor air analytes were detected above screening levels at Building 1098. Therefore, no Expedited Building Summary (EBS) was necessary.

DATA SUMMARY

The analytical results were compared to the EGLE August 2017 Media-Specific Volatilization to Indoor Air Interim Action Screening Levels, the EGLE draft project-specific 12-hour Soil Gas screening values and acceptable air concentrations (AACs) (draft project-specific RIASL₁₂), and the Dow OELs.

Building 1098 is approximately 6,250 ft² in size. For each sampling event, sub-slab soil gas samples were collected from four locations from within the building. Indoor air samples were collected at four locations corresponding to the soil gas sample locations, along with an outdoor air sample from the main air intake. The sampling locations are shown on Figure 5.2.6-2. Summary statistics and screening comparison results are presented for sub-slab soil gas on Table 5.2.6-A and indoor and outdoor air on Table 5.2.6-B. The 2019 analytical data is presented in Appendix A. Field sampling logs are provided in Appendix B.

The building survey was completed before the initial sampling event. Drains and other openings were screened with a PID and no soil gas entry points were identified. A chemical inventory was completed during the building survey and a wide variety of chemicals were found to be stored within the building (e.g., various cleaners, stains, degreasers, primers, galvanizers). The survey and chemical inventory were included in the 2018 CAIP.

SUB-SLAB SOIL GAS RESULTS EVALUATION

Analytical results were evaluated based on methodologies presented in the 2018 Revised Vapor Intrusion Work Plan. The number of analytes detected above the draft project-specific RIASL₁₂ or TSRIASL₁₂, if available, are listed below by sampling event:

1. During the initial event (Fall 2016), 1,4-DCB and CFC-12 were detected above the draft project-specific RIASL₁₂;
2. During the second event (Spring 2019), all analytes were below screening levels; and
3. During the third event (Summer 2019), four analytes were detected above the draft project-specific RIASL₁₂ including benzene, hexane, and TCE which were also detected above the TSRIASL₁₂.

The sub-slab soil gas results for the analytes that exceed the applicable screening level are summarized for each sampling event in Table 1098-1.

Table 1098-1. Summary of Sub-Slab Soil Gas Exceedances for Building 1098

Analyte (Sampling Event)	Detection Frequency	Measured Range of Detects ($\mu\text{g}/\text{m}^3$)	% Detections > Screening Level	Screening Level* ($\mu\text{g}/\text{m}^3$)
1,4-Dichlorobenzene (1)	25%	1,800	25%	1,000
1,4-Dichlorobenzene (2)	25%	360	0%	1,000
1,4-Dichlorobenzene (3)	25%	720	0%	1,000
Benzene (1)	50%	45 - 410	0%	510
Benzene (2)	25%	19	0%	510
Benzene (3)	50%	590 - 1,900	50%	510
CFC-12 (1)	100%	6,600 - 320,000	50%	34,000
CFC-12 (2)	100%	860 - 12,000	0%	34,000
CFC-12 (3)	100%	4,100 - 290,000	25%	34,000
Hexane (1)	100%	200 - 15,000	0%	72,000
Hexane (2)	100%	54 - 2,100	0%	72,000
Hexane (3)	75%	1,500 - 260,000	25%	72,000
TCE (1)	0%	ND	0%	130
TCE (2)	25%	100	0%	130
TCE (3)	25%	410	25%	130

*Screening level provided is the draft project-specific RIASL₁₂.

Table 1098-2 summarizes the indoor air results relative to the sub-slab soil gas exceedances, since VI only potentially occurs if the analyte is present in both sub-slab soil gas and indoor air. Therefore, the table below provides the analytes detected above applicable screening levels in sub-slab soil gas as well as the corresponding indoor air sample results. The outdoor air sample results are also provided to determine if the analytes were present in indoor air due to migration from outdoor air.

Table 1098-2. Vapor Intrusion Evaluation for Building 1098

Analyte	Indoor Air Detection Frequency	Indoor Air Measured Range ($\mu\text{g}/\text{m}^3$)	Indoor Air Screening Level* ($\mu\text{g}/\text{m}^3$)	Outdoor Air Result ($\mu\text{g}/\text{m}^3$)
1,4-Dichlorobenzene (1)	0%	ND	30	ND
1,4-Dichlorobenzene (2)	0%	ND	30	ND
1,4-Dichlorobenzene (3)	0%	ND	30	ND
Benzene (1)	0%	ND	15.4	3.5
Benzene (2)	50%	0.28 - 0.34	15.4	0.38
Benzene (3)	100%	0.44 - 0.72	15.4	0.36
CFC-12 (1)	100%	4.4 - 11	1,020	ND
CFC-12 (2)	100%	2.6 - 4.2	1,020	3.1
CFC-12 (3)	100%	4.9 - 10	1,020	2.3
Hexane (1)	75%	3.5 - 8	2,200	9.9
Hexane (2)	25%	5.2	2,200	ND
Hexane (3)	100%	3.2 - 14	2,200	ND
TCE (1)	0%	ND	4	ND
TCE (2)	25%	1.0	4	ND
TCE (3)	100%	0.17 - 2.2	4	ND

*Screening level provided is the draft project-specific RIASL₁₂.

All indoor air results for Building 1098 are less than screening levels.

An ND evaluation will be performed upon completion of seasonal confirmation sampling.

CONCLUSIONS AND RECOMMENDATIONS

Based on the indoor air results, the VI pathway at Building 1098 is an insignificant exposure pathway based on current use. However, based on the sub-slab soil gas results and given the potential for future

VI, Building 1098 remains in VI Path Forward Building Group 2, seasonal confirmation sampling continues, and a full evaluation will be presented in the 2020 CAIP.

5.2.7 Vapor Intrusion Evaluation Summary for Building 1159

BACKGROUND

Building 1159 is a Zone 1 add-on building that was identified in 2017 and is attached to Building 3303. Building 1159 is located in the southwestern quadrant of the facility near Gate 23 and is known as the EVO Maintenance Shop. This building is connected to Building 3303 via doorways to a locker room and hallway leading to the main shop area. Building 3303 is a Zone 1 building evaluated in the 2017 CAIP and all results from the two sample locations collected in late 2016 were below screening levels. Both Buildings 3303 and 1159 appear to have been built between 1965 and 1982. Building 1159 is a 8,976 ft² slab-on-grade single-story structure with no basement or elevator. Building 1159 consists of a locker room, an expendable stocking area, and two large shop areas. The ground cover around the outside of the building is predominantly asphalt.

Building 1159 is heated via ceiling mounted electrical heaters. The locker room is cooled via central AC. The smaller of the two shop areas has a small individual AC unit, but it appears mechanical fans used in tandem with open bay doors are used to cool the shop area in warmer months. The building has three bay doors that are typically open most of the time during the summer and opened rarely during the winter. A shared intake for 3303 and the locker room for 1159 is located near the southeastern side of the structure.

The occupants of this building work 10-hour shifts Monday through Thursday. Approximately 10-15 people use the shop area and locker room in this building. The workers in this building use either a contracted laundry service or the washer/dryers found in the locker room.

SUB-SLAB SOIL GAS RESULTS EVALUATION SUMMARY

Building 1159 was sampled in November 2017 and the VI evaluation was presented in Section 5.1.8 of the 2018 CAIP. Analytical results were evaluated based on methodologies presented in the 2018 Revised Vapor Intrusion Work Plan. Forty-seven of the 65 analytes were ND in the five sub-slab soil gas samples. Eighteen analytes were detected in sub-slab soil gas and all detected results were below the sub-slab soil gas draft project-specific RIASL₁₂ and/or TSRIASL₁₂, if available. Summary statistics and screening comparison results are presented for sub-slab soil gas on Table 5.2.7-A and indoor and outdoor air on Table 5.2.7-B.

The 2017 VI sampling event demonstrated that all sub-slab soil gas results were below screening levels; however, PCE and TCE were detected in indoor air at concentrations above screening levels. An EBS was submitted for Building 1159 on August 24, 2018 due to indoor air PCE concentrations greater than the TSRIASL₁₂.

FURTHER INVESTIGATIVE FINDINGS SUMMARY

The goal of the further investigation activities was to confirm that the indoor air exceedances of PCE and TCE were due to active workplace chemical use and not attributable to VI. The *Summary of VI Investigative Findings* for Building 1159 was submitted to EGLE in October 2019 (Included in Appendix C).

During the July 10th investigation, it was observed that PCE and TCE were used and emitted during daily workplace operations in Building 1159. Degreaser cans, most of which consist of PCE, were found opened on multiple work benches in the shop area, which indicated frequent use. Prior Field GC sampling has demonstrated that the storage of unopened degreasers produces small emissions, while opened PCE and TCE aerosol degreaser canisters can produce a higher rate of off-gassing. At Building

1159, the samples with higher PCE or TCE concentrations were collected closer to these workplace sources. Additionally, the PID readings along the drainage structure suggested that it is likely that degreaser from workplace use is washed down into the drainage structure. This evidence suggests that the indoor air exceedances in Building 1159 are due to active workplace chemical use and not attributable to VI.

During the initial VI sampling effort, all sub-slab soil gas results for TCE were ND. While PCE was detected in all sub-slab soil gas samples, the maximum detected concentration was $160 \mu\text{g}/\text{m}^3$ compared to a $\text{RIASL}_{12}/\text{TSRIASL}_{12}$ of $2,700 \mu\text{g}/\text{m}^3$. Furthermore, the maximum concentration of TCE detected in indoor air during the further investigation activities ($3.23 \mu\text{g}/\text{m}^3$) was below the RIASL_{12} of $4 \mu\text{g}/\text{m}^3$. The maximum concentration of PCE detected in indoor air during the investigation ($45.4 \mu\text{g}/\text{m}^3$) was also below the $\text{RIASL}_{12}/\text{TSRIASL}_{12}$ of $82 \mu\text{g}/\text{m}^3$.

CONCLUSIONS AND RECOMMENDATIONS

The VI pathway at Building 1159 is an insignificant exposure pathway based on current use. The further investigation activities conducted in July 2019 confirm that the indoor air exceedances detected at Building 1159 are due to active workplace chemical use and not attributable to VI. No further action is warranted at this time for VI at Building 1159.

5.3 Zone 2 Phase 1 Evaluations

The Zone 2 Phase 1 buildings were evaluated in the 2017 CAIP (December 2017), the 2018 Vapor Intrusion Rescreen of Zone 1 and Zone 2 Phase 1 Report (August 2018), and in the 2018 CAIP (January 2019). Zone 2 Phase 1 VI results and evaluations are presented for the buildings listed below in the following subsections:

- Section 5.3.1 Building 833;
- Section 5.3.2 Building 941;
- Section 5.3.3 Building 1028;
- Section 5.3.4 Building 1233;
- Section 5.3.5 Building 827;
- Section 5.3.6 Building 948;
- Section 5.3.7 Building 1025;
- Section 5.3.8 Building 768;
- Section 5.3.9 Building 849;
- Section 5.3.10 Building 858;
- Section 5.3.11 Building 969; and
- Section 5.3.12 Building 1222.

5.3.1 Vapor Intrusion Evaluation Summary for Building 833

Building 833 is a Category 2 building located within the central portion of the facility designated as Zone 2. Building 833 has office space, sampling supply storage and a sample preparation area. It is approximately 5,220 ft² and is known as the Craft Services Fab Shop. The October 2016 VI sampling event demonstrated that all sub-slab soil gas results for Building 833 were below screening levels.

The results of the initial sampling event were presented in the 2017 CAIP and re-evaluated in the 2018 Rescreen. Analytical results were evaluated based on methodologies presented in the 2018 Revised Vapor Intrusion Work Plan. Forty-five of the 65 analytes were ND in the five sub-slab soil gas samples. Twenty analytes were detected in sub-slab soil gas and all detected results were below the sub-slab soil gas draft project-specific RIASL₁₂ and/or TSRIASL₁₂, if available. The findings of the rescreen supported the conclusions of the 2017 CAIP. The VI Pathway at Building 833 is an insignificant exposure pathway based on current use; however, due to the slight exceedance of chloroform in indoor air Building 833 was moved into VI Path Forward Building Group 3 and further investigation into the indoor air exceedance would be conducted. Summary statistics and screening comparison results are presented for sub-slab soil gas on Table 5.3.1-A and indoor and outdoor air on Table 5.3.1-B.

FURTHER INVESTIGATIVE FINDINGS SUMMARY

The *Summary of VI Investigative Findings* for Building 833 was submitted to EGLE in October 2019 (Included in Appendix C). The goal of the further investigation activities was to confirm that the indoor air exceedances of chloroform was due to active workplace chemical use and not attributable to VI.

During the July 15th investigation, a sample concentration gradient appeared to originate from the current sample storage room where highly impacted environmental and waste samples were stored in refrigerators and ice boxes. In addition, there is an ice maker and sink found in the same room. The source of chloroform is likely a mixture of sample off-gassing, the use of cleaning products, and treated water in the sample storage room.

Chloroform was not detected in sub-slab soil gas at Building 833. The sub-slab soil gas ND RL from the sample collected in the former sample storage room was 3.2 $\mu\text{g}/\text{m}^3$ compared to a RIASL₁₂ of 170 $\mu\text{g}/\text{m}^3$ and a TSRIASL₁₂ of 1,700 $\mu\text{g}/\text{m}^3$. Furthermore, the maximum concentration of chloroform detected in indoor air during the further investigation activities was 5.98 $\mu\text{g}/\text{m}^3$, compared to a RIASL₁₂ of 5.2 $\mu\text{g}/\text{m}^3$ and a TSRIASL₁₂ of 52 $\mu\text{g}/\text{m}^3$. All other indoor air results during the investigation were below the RIASL₁₂ for chloroform.

CONCLUSIONS AND RECOMMENDATIONS

The VI pathway at Building 833 is an insignificant exposure pathway based on current use. The further investigation activities conducted in July 2019 confirm that the indoor air exceedances detected at Building 833 are not attributable to VI. No further action is warranted at this time for VI at Building 833.

5.3.2 VI Seasonal Confirmation Sampling Results Evaluation for Building 941

INTRODUCTION

Building 941 is a Category 1 building located in the central portion of the facility designated as Zone 2 (Figure 5.3.2-1). It is known as the Specialty Intermediates/Herbicides Inter Control Room and is a large, single-story building that includes process area, laboratory, and office space.

The results of the initial sampling event were evaluated in the 2017 CAIP and then re-evaluated in the 2018 Rescreen. An EBS was submitted for Building 941 on August 24, 2018. Email notifications were provided to EGLE in January, April, July, and October 2019. PCE and TCE were the only analytes identified at that time in indoor air detected at Building 941 greater than the TSRIASL₁₂. The first four sampling events (E1 - E4) were evaluated and presented in Section 5.2.3 of the 2018 CAIP. Since that time, four additional seasonal confirmation sampling events have been performed.

Building 941	
Initial Sampling Event	Completed
E1	May 2017 (Spring)
Seasonal Confirmation Sampling Event	Completed
E2	September 2017 (Fall)
E3	February 2018 (Winter)
E4	August 2018 (Summer)
E5	November 2018 (Fall)
E6	February 2019 (Winter)
E7	April 2019 (Spring)
E8	August 2019 (Summer)

There are 12 sub-slab soil gas AOIs: 1,1,2-TCA, 1,1-DCE, EDC, bromodichloromethane, bromomethane, carbon tetrachloride, chloroform, chloromethane, cis-1,2-DCE, naphthalene, PCE, and TCE, due to exceedances of the draft project-specific RIASL₁₂ and/or the TSRIASL₁₂. Of those 12 analytes, seven analytes have exceedances in indoor air, and four of those analytes exceeded the indoor air TSRIASL₁₂.

Indoor air and sub-slab soil-gas samples were collected during each event at nine locations within the building and concurrent outdoor air samples were collected at one location (Figure 5.3.2-2). Figures 941-1 through 941-7 present the sub-slab soil gas and indoor air results at each sample location per event for the seven analytes detected in both media: EDC, 1,1,2-TCA, chloroform, chloromethane, cis-1,2-DCE, PCE, and TCE, respectively.

VAPOR INTRUSION CONCEPTUAL SITE MODEL

VI is an exposure pathway that involves the migration of volatilized chemicals from the subsurface to indoor air in overlying, occupied buildings. A source, migration route and a human receptor must be present for the VI pathway to be complete. The focus of this building specific investigation is to evaluate the potential VI exposure pathway for occupants at Building 941. The CSM is illustrated in Figure 5.3.2-3.

Building 941 is a single-story building that contains office space, laboratory, and process area. The building is slab-on-grade construction with a footprint of approximately 10,360 ft² (962 m²). The building has two central AC units with one air intake. There are two bay doors that are only opened to receive materials and equipment.

The only underground utilities are the sewer lines. There are multiple floor drains and various plumbing fixtures. The land surrounding the building is covered in asphalt. The depth to groundwater in this area of the facility is approximately 5 ft bgs and the soils are largely fill material. Groundwater flow is towards the south or southwest.

The typical parameters for non-residential exposures are assumed to apply to workers at this building (i.e., 40 hours/week, 50 weeks/year exposure).

A building survey was performed on March 7, 2017. Drains and other openings were screened with a PID and no soil gas entry points were identified at that time. As indicated above, subsequent investigations identified floor seams as a point of vapor entry. A chemical inventory was completed during the building survey and identified degreasers, cleaners, motor oil, and insecticides.

Further investigation activities were conducted in March and May 2019 using real-time measurement devices to identify potential pathways for VI. Findings were reported in the June 2019 Summary of Investigative Findings (see Appendix C). During these activities, it was determined that there is a preferential pathway in the women's locker room (941-xx-04) but a specific source has not been identified; however, the concentrations were not as high as would be expected if this was a preferential pathway responsible for TCE concentrations throughout the building. Results from the conference room (941-xx-02) over- and under-pressurizing confirmed any source for TCE concentrations is outside the conference room. Joint seams were identified immediately outside the conference room and around the perimeter of the glass cleaning shop and confirmed as a source of VI.

Dow implemented an interim action to seal the joint seams and this activity was completed on April 11, 2019; however, as discussed in the July 2019 Corrective Action status meeting, the sealed joint seams are not providing a significant reduction in indoor air results.

EVALUATION OF SEASONAL CONFIRMATION SAMPLING EVENTS

This evaluation includes eight seasonal sampling events (E1-E8) that have been conducted at Building 941. The sampling events encompass approximately three years of time and include sampling during each season of the year. Summary statistics and screening comparison results for each sampling event

are presented for sub-slab soil gas on Table 5.3.2-A and indoor and outdoor air on Table 5.3.2-B. The analytical reports are presented in Appendix A. Field sampling logs are provided in Appendix B.

The results from the eight seasonal confirmation sampling events were evaluated with respect to spatial variability, temporal variability, and seasonal trend analysis. Building specific attenuation factors were calculated and compared between events to evaluate temporal variability and determine the best estimate of a building-specific attenuation factor. This evaluation serves to confirm that the existing study design is appropriate, and also provides insight for the determination of the path forward for this building.

This evaluation focused on any analytes detected in the sub-slab soil gas samples that met the criterion for inclusion in one or more of the following categories:

- a) Analytes detected in sub-slab soil gas at concentrations that exceeded draft project-specific screening levels;
- b) Analytes detected in sub-slab soil gas at concentrations of 1,000 $\mu\text{g}/\text{m}^3$ or greater in one or more samples. Data for analytes detected above 1,000 $\mu\text{g}/\text{m}^3$ should provide the clearest signal and be the simplest to interpret when assessing data trends. The same data trends observed for these analytes are expected to apply to other similar analytes present at lower concentrations; and
- c) PCE and TCE. These two analytes are of particular interest for many VI evaluations at industrial sites.

For this building, the analytes detected in the sub-slab soil gas at concentrations above the draft project-specific screening levels were the following 12 compounds: 1,1,2-TCA, 1,1-DCE, EDC, bromodichloromethane, bromomethane, carbon tetrachloride, chloroform, chloromethane, cis-1,2-DCE, naphthalene, PCE, and TCE.

Eight other analytes were detected at concentrations $\geq 1,000 \mu\text{g}/\text{m}^3$ in sub-slab soil gas: 1,1,1-TCA, CFC-12, methylene chloride, chloroethane, acetone, 2,2,4-trimethylpentane, total xylenes, and 1,2,4-TMB. Given the quantity of analytes to consider, only 1,1,1-TCA is also included in this evaluation. 1,1,1-TCA had relatively high sub-slab concentrations and was consistently detected in both indoor air and soil gas. The other seven analytes are not included in this evaluation due to their low detection frequency and/or relatively low concentrations at many locations. Sample results for the 13 analytes included in this evaluation are provided in the data tables below:

Summary of Results for 1,1,2-Trichloroethane (1,1,2-TCA)

Sample Type	Sample ID	Measured Concentration ($\mu\text{g}/\text{m}^3$)							
		May 2017	Sep. 2017	Feb. 2018	Aug. 2018	Nov. 2018	Feb. 2019	Apr. 2019	Aug. 2019
		E1	E2	E3	E4	E5	E6	E7	E8
Outdoor Air	941-OA-01	<0.18	<0.19	<0.17	<0.18	<0.17	<0.19	0.21	<0.19
Indoor Air	941-IA-01	0.19	0.24	<0.18	0.44	1.8	0.71	0.83	0.40
	941-IA-02	1.4	0.24	12	0.30	23	5.1	15	4.2
	941-IA-03	0.99	0.25	1	0.43	4	1.9	9.6	2.9
	941-IA-04	1.1	0.37	10	0.31	16	3	12	3.3
	941-IA-05	0.58	0.29	0.52	0.32	18	0.68	5.4	1.5
	941-IA-06	1	0.44	5.9	0.34	0.84	2.2	12	3.3
	941-IA-07	0.54	0.48	5.3	0.35	6.4	2.4	13	3
	941-IA-08	1	<0.19	5.3	0.33	6.1	2.5	13	2.9
	941-IA-09	1.8	0.58	3.6	0.41	6	2.7	25	4.1
Sub-Slab Soil Gas	941-SS-01	8.1	25	11	<10	<4.3	<4.2	8.8	<8.6
	941-SS-02	12,000	5,300	8,100	4,600	9,400	<430	17,000	5,300
	941-SS-03	36	20	26	54	32	<4.2	24	36
	941-SS-04	<230	<150	5,700	<210	<240	<200	10,000	<98
	941-SS-05	1,600	2,300	2,400	2,500	2,800	<82	2,100	2,400
	941-SS-06	110	120	130	100	180	<15	260	250
	941-IA-07	<4.6	<5.6	<4.2	<4.1	<4.4	<4.3	<4.1	<4.2
	941-IA-08	15	18	22	<17	18	<4.3	9.7	23
	941-IA-09	23	34	17	79	56	<4.4	150	110

Screening levels for indoor air are $0.62 \mu\text{g}/\text{m}^3$ (RIASL₁₂)

Screening levels for soil-gas are $20 \mu\text{g}/\text{m}^3$ (RIASL₁₂)

Summary of Results for 1,1-Dichloroethene (1,1-DCE)

Sample Type	Sample ID	Measured Concentration ($\mu\text{g}/\text{m}^3$)							
		May 2017	Sep. 2017	Feb. 2018	Aug. 2018	Nov. 2018	Feb. 2019	Apr. 2019	Aug. 2019
		E1	E2	E3	E4	E5	E6	E7	E8
Outdoor Air	941-OA-01	0.29	0.14	0.11	0.24	2.5	1.2	3.2	<0.068
Indoor Air	941-IA-01	0.41	0.56	0.08	0.27	13	3.2	4.9	0.27
	941-IA-02	1.3	0.80	4.7	0.53	23	15	31	10
	941-IA-03	0.88	0.61	0.48	0.32	10	5.2	1.6	0.81
	941-IA-04	1.1	1.2	14	0.52	27	6.3	13	4.2
	941-IA-05	2	4.4	4.5	3.5	29	8.7	25	8.2
	941-IA-06	0.89	1.2	2.4	0.54	19	2.7	1.4	1.4
	941-IA-07	0.62	1	2.3	0.52	8.6	5.8	19	6.2
	941-IA-08	0.93	4.4	2.3	0.51	7.7	7.2	24	5.4
	941-IA-09	1.2	1.2	1.5	0.86	8.8	7.4	24	5.1
Sub-Slab Soil Gas	941-SS-01	11	38	50	70	100	51	200	160
	941-SS-02	2,100	20,000	800	18,000	3,700	18,000	120,000	4,900
	941-SS-03	71	28	72	43	37	20	28	81
	941-SS-04	9,800	9,300	7,200	16,000	9,200	18,000	15,000	14,000
	941-SS-05	4,600	37,000	7,200	53,000	11,000	33,000	12,000	44,000
	941-SS-06	5,300	1,900	2,000	830	1,500	1,100	1,400	2,400
	941-IA-07	17	55	51	9.5	30	9.2	18	52
	941-IA-08	55	160	130	150	22	10	36	780
	941-IA-09	200	220	220	510	530	11	960	1,800

Screening levels for indoor air are $620 \mu\text{g}/\text{m}^3$ (RIASL₁₂) and $1,900 \mu\text{g}/\text{m}^3$ (TSRIASL₁₂)
Screening levels for soil-gas are $20,000 \mu\text{g}/\text{m}^3$ (RIASL₁₂) and $61,000 \mu\text{g}/\text{m}^3$ (TSRIASL₁₂)

	RIASL ₁₂ Exceedance
	TSRIASL ₁₂ Exceedance

Summary of Results for 1,2-Dichloroethane (EDC)

Sample Type	Sample ID	Measured Concentration ($\mu\text{g}/\text{m}^3$)							
		May 2017	Sep. 2017	Feb. 2018	Aug. 2018	Nov. 2018	Feb. 2019	Apr. 2019	Aug. 2019
		E1	E2	E3	E4	E5	E6	E7	E8
Outdoor Air	941-OA-01	0.54	<0.14	0.24	0.20	0.10	<0.14	0.31	<0.14
Indoor Air	941-IA-01	0.76	0.26	0.30	0.88	1	0.45	0.86	0.40
	941-IA-02	1.9	0.26	14	0.55	12	2.9	12	3.2
	941-IA-03	1.5	0.31	1.6	0.81	2.1	1.2	8.3	2.5
	941-IA-04	1.6	0.38	9.5	0.55	8.5	1.8	11	3.1
	941-IA-05	1	0.18	0.48	0.41	0.43	0.49	4.8	1.3
	941-IA-06	1.6	0.45	8.2	0.56	3.6	1.4	10	3
	941-IA-07	0.80	0.46	7.4	0.62	3.3	1.6	11	2.8
	941-IA-08	1.4	0.16	7.4	0.55	3.3	1.7	11	2.7
	941-IA-09	2.4	0.56	4.8	0.63	6.8	1.7	22	3.6
Sub-Slab Soil Gas	941-SS-01	<3.6	<6.4	<4.3	<7.5	<3.2	<3.2	<3.2	<6.4
	941-SS-02	14,000	2,800	16,000	2,800	5,300	8,200	12,000	6,100
	941-SS-03	<3.1	<3.1	<3.2	<3.1	<3	<3.2	<3	<3.3
	941-SS-04	3,800	1,300	3,700	2,900	4,700	2,800	4,800	2,800
	941-SS-05	670	810	770	690	620	440	310	470
	941-SS-06	<14	<20	<6.8	<12	19	22	22	26
	941-IA-07	4	<4.2	<3.1	<3	<3.3	<3.2	<3	<3.1
	941-IA-08	<8.1	<14	<5.3	<12	5.1	<3.2	7.2	<10
	941-IA-09	4.6	6.3	6.8	16	15	<3.2	34	46

Screening levels for indoor air are $4.6 \mu\text{g}/\text{m}^3$ (RIASL₁₂)

Screening levels for soil-gas are $150 \mu\text{g}/\text{m}^3$ (RIASL₁₂)

Summary of Results for Bromodichloromethane

Sample Type	Sample ID	Measured Concentration ($\mu\text{g}/\text{m}^3$)							
		May 2017	Sep. 2017	Feb. 2018	Aug. 2018	Nov. 2018	Feb. 2019	Apr. 2019	Aug. 2019
		E1	E2	E3	E4	E5	E6	E7	E8
Outdoor Air	941-OA-01	<1.1	<1.2	<1.1	<1.1	<1	<1.2	<1.1	<1.1
Indoor Air	941-IA-01	<1	<1.1	<1.1	<1.1	<1.1	<1.2	<1.1	<11
	941-IA-02	<1.1	<1.1	<1.1	<1.2	<1.1	<2.2	<5.7	<1.2
	941-IA-03	<1.1	<1.2	<1.1	<1.2	<1.2	<1.2	<1.2	<1.2
	941-IA-04	<1.1	<1.1	<11	<1.1	<2.4	<1.1	<2.7	<1.2
	941-IA-05	<1.1	<1	<1	<1.2	<2.2	<1.2	<6.9	<1.2
	941-IA-06	<1.1	<1.1	<1.2	<1.1	<1.1	<1.2	<2.2	<1.1
	941-IA-07	<1.1	<1.1	<1.2	<1.1	<1.1	<1.1	<5.8	<1.1
	941-IA-08	<1.1	<1.1	<1.2	<1.1	<1.1	<1.2	<5.6	<1.2
	941-IA-09	<1.1	<1.1	<1.2	<1.2	<1.4	<1.1	<3.7	<1.2
Sub-Slab Soil Gas	941-SS-01	<5.9	<10	<7.2	<12	<5.2	<5.2	<5.3	550
	941-SS-02	290	240	280	<110	490	<530	<13,000	<5.5
	941-SS-03	<5.2	<5.1	<5.3	<5.2	<5	<5.2	<4.9	230
	941-SS-04	<290	<180	<280	<260	<290	<250	<250	160
	941-SS-05	190	220	250	150	200	210	140	<17
	941-SS-06	<24	<34	<11	<20	<14	<19	<17	<5.2
	941-IA-07	<5.7	<6.9	<5.2	<5	<5.5	<5.3	<5	<17
	941-IA-08	<13	<23	<8.8	<21	7.1	<5.3	<5.3	<12
	941-IA-09	<5.1	<5.4	<4.5	<13	5.7	<5.4	<21	550

Screening levels for indoor air are $6.2 \mu\text{g}/\text{m}^3$ (RIASL₁₂)

Screening levels for soil-gas are $200 \mu\text{g}/\text{m}^3$ (RIASL₁₂)

	RIASL12 Exceedance
	TSRIASL12 Exceedance

Summary of Results for Bromomethane

Sample Type	Sample ID	Measured Concentration ($\mu\text{g}/\text{m}^3$)							
		May 2017	Sep. 2017	Feb. 2018	Aug. 2018	Nov. 2018	Feb. 2019	Apr. 2019	Aug. 2019
		E1	E2	E3	E4	E5	E6	E7	E8
Outdoor Air	941-OA-01	<3.2	<3.4	<3.1	<3.3	<3.1	<3.4	<3.2	<3.3
Indoor Air	941-IA-01	<3	<3.1	<3.2	<33	<3.3	<3.4	<3.2	<3.4
	941-IA-02	<3.2	<3.2	<3.3	<33	<3.2	<6.5	<16	<3.4
	941-IA-03	<3.2	<3.4	<3.3	<34	<3.5	<3.3	<7.8	<3.5
	941-IA-04	<3.2	<3.3	<33	<32	<7	<3.5	<20	<3.3
	941-IA-05	<3.3	<3	<3	<34	<6.5	<3.3	<17	<3.6
	941-IA-06	<3.2	<3.2	<3.5	<32	<3.3	<3.5	<16	<3.4
	941-IA-07	<3.3	<3.3	<3.5	<33	<3.1	<3.3	<11	<3.4
	941-IA-08	<3.3	<3.3	<3.4	<33	<3.3	<3.3	<15	<3.4
	941-IA-09	<3.2	<3.1	<3.6	<34	<4.1	<3.5	<27	<3.1
Sub-Slab Soil Gas	941-SS-01	<34	<61	<42	<72	<30	<30	<31	<62
	941-SS-02	<660	<260	<310	<260	<420	<1,200	32,000	<580
	941-SS-03	<30	<30	<31	<30	<29	<30	<28	<32
	941-SS-04	<670	<420	<650	<600	<670	<570	<590	<280
	941-SS-05	<320	<240	<290	<230	<180	<230	<200	<130
	941-SS-06	<140	<200	<65	<110	<83	<110	<100	<99
	941-IA-07	<33	<40	<30	<29	<32	<31	<29	<30
	941-IA-08	<78	<130	<51	<120	<31	<31	<31	<96
	941-IA-09	<30	<31	<26	<75	<33	<31	<120	<68

Screening levels for indoor air are 30 $\mu\text{g}/\text{m}^3$ (RIASL₁₂)

Screening levels for soil-gas are 1,000 $\mu\text{g}/\text{m}^3$ (RIASL₁₂)

Summary of Results for Carbon Tetrachloride

Sample Type	Sample ID	Measured Concentration ($\mu\text{g}/\text{m}^3$)							
		May 2017	Sep. 2017	Feb. 2018	Aug. 2018	Nov. 2018	Feb. 2019	Apr. 2019	Aug. 2019
		E1	E2	E3	E4	E5	E6	E7	E8
Outdoor Air	941-OA-01	0.69	0.35	0.60	0.51	0.54	0.55	0.63	0.47
Indoor Air	941-IA-01	0.76	0.34	0.47	0.60	0.53	0.69	0.72	0.48
	941-IA-02	2	0.32	4.3	0.67	2.4	1.7	3.9	1.2
	941-IA-03	1.5	0.29	0.78	0.56	0.65	0.95	1.5	0.80
	941-IA-04	1.6	0.55	4.9	0.53	3.6	1.2	2.5	1.1
	941-IA-05	1.6	0.52	0.94	0.77	1	0.76	1.4	0.76
	941-IA-06	1.6	0.61	2.3	0.46	1	1	2.6	0.92
	941-IA-07	0.76	0.63	2	0.47	0.85	1.1	3.2	0.88
	941-IA-08	1.6	0.32	2	0.49	0.95	1.1	2.6	0.90
	941-IA-09	2.3	0.70	1.3	0.49	1.1	1.1	4.1	0.97
Sub-Slab Soil Gas	941-SS-01	<5.5	<9.9	<6.7	<12	<4.9	<4.9	<5	<10
	941-SS-02	2,000	6,300	4,800	1,700	380	1,100	<13,000	920
	941-SS-03	<4.9	<4.8	<5	<4.8	<4.6	<4.9	<4.6	<5.2
	941-SS-04	4,800	2,100	2,800	2,400	1,800	1,400	2,100	1,000
	941-SS-05	4,500	4,900	1,900	3,800	1,400	840	860	740
	941-SS-06	<22	42	150	170	300	210	250	300
	941-IA-07	<5.3	<6.5	6.8	<4.7	12	<5	13	8.3
	941-IA-08	<13	23	14	60	38	5	<5	79
	941-IA-09	13	13	9.3	17	19	<5.1	34	47

Screening levels for indoor air are 22 $\mu\text{g}/\text{m}^3$ (RIASL₁₂)

Screening levels for soil-gas are 710 $\mu\text{g}/\text{m}^3$ (RIASL₁₂)

	RIASL12 Exceedance
	TSRIASL12 Exceedance

Summary of Results for Chloroform

Sample Type	Sample ID	Measured Concentration (µg/m ³)							
		May 2017	Sep. 2017	Feb. 2018	Aug. 2018	Nov. 2018	Feb. 2019	Apr. 2019	Aug. 2019
		E1	E2	E3	E4	E5	E6	E7	E8
Outdoor Air	941-OA-01	0.18	0.33	0.43	0.20	0.22	0.67	0.35	<0.17
Indoor Air	941-IA-01	0.30	0.76	0.16	0.85	0.59	0.66	0.72	0.32
	941-IA-02	2.4	1.4	15	0.98	18	4.9	23	6
	941-IA-03	1.6	1.1	1.4	0.84	2.1	2.6	11	4.2
	941-IA-04	2	3.6	15	1.2	17	3	25	6.2
	941-IA-05	1.8	3.5	1.8	1.6	18	1.3	12	3.4
	941-IA-06	1.8	3.9	7.8	1	3.6	2.3	22	5
	941-IA-07	0.97	4.8	7.2	1.1	5	2.5	26	4.7
	941-IA-08	1.8	2.8	7.3	0.95	4.5	2.6	26	4.6
	941-IA-09	3.4	6.3	5.4	1.5	4.4	3	60	6.6
Sub-Slab Soil Gas	941-SS-01	5.1	25	16	33	20	6.2	24	46
	941-SS-02	11,000	12,000	15,000	6,700	5,900	7,900	18,000	9,000
	941-SS-03	12	6.2	6.1	12	8.2	4.9	9.7	9.8
	941-SS-04	11,000	5,400	9,000	8,400	11,000	7,500	11,000	6,700
	941-SS-05	8,100	11,000	7,400	9,600	8,400	4,000	3,800	5,000
	941-SS-06	220	230	560	280	570	440	540	780
	941-IA-07	17	53	79	15	120	9.5	120	65
	941-IA-08	86	320	250	420	420	81	33	640
	941-IA-09	39	110	58	240	290	5.9	380	780

Screening levels for indoor air are 5.2 µg/m³ (RIASL₁₂) and 52 µg/m³ (TSRIASL₁₂)
Screening levels for soil-gas are 170 µg/m³ (RIASL₁₂) and 1,700 µg/m³ (TSRIASL₁₂)

Summary of Results for Chloromethane

Sample Type	Sample ID	Measured Concentration (µg/m ³)							
		May 2017	Sep. 2017	Feb. 2018	Aug. 2018	Nov. 2018	Feb. 2019	Apr. 2019	Aug. 2019
		E1	E2	E3	E4	E5	E6	E7	E8
Outdoor Air	941-OA-01	1.7	5.4	<1.6	2.5	<1.6	<1.8	2.8	<1.8
Indoor Air	941-IA-01	2.3	4.1	5.6	<1.8	<1.8	<1.8	4.5	2
	941-IA-02	1.8	4.7	6.1	<1.8	2.7	<3.5	230	2.1
	941-IA-03	2.2	3.8	6.5	<1.8	<1.8	<1.7	120	2.3
	941-IA-04	1.7	5.9	<17	<1.7	<3.7	<1.8	210	2.2
	941-IA-05	1.9	7	6.3	<1.8	<1.8	<1.7	81	1.9
	941-IA-06	1.6	5.6	6.5	<1.7	<1.7	<1.8	190	2.1
	941-IA-07	0.76	4.5	6.8	<1.7	<1.7	<1.8	220	2.2
	941-IA-08	1.7	21	6.8	<1.7	<2.2	<1.8	210	2.1
	941-IA-09	1.8	4.4	4.3	<1.8	<1.7	<1.8	420	2
Sub-Slab Soil Gas	941-SS-01	<18	<33	<22	<38	<16	<16	<16	<33
	941-SS-02	<350	<140	<160	<140	<220	<660	700,000	<310
	941-SS-03	<16	<16	<16	<16	<15	<16	34	<17
	941-SS-04	<360	<220	<350	<320	<360	<300	1300	<150
	941-SS-05	<170	<130	<160	<120	<96	<120	<110	<69
	941-SS-06	<72	<100	<34	<61	<44	<58	53	<53
	941-IA-07	<18	<21	<16	<15	<17	<16	<15	<16
	941-IA-08	<42	<70	<27	<64	<16	<16	240	<51
	941-IA-09	<16	<16	<14	<40	<18	<17	<65	<36

Screening levels for indoor air are 280 µg/m³ (RIASL₁₂) and 410 µg/m³ (TSRIASL₁₂)
Screening levels for soil-gas are 9,200 µg/m³ (RIASL₁₂) and 14,000 µg/m³ (TSRIASL₁₂)

	RIASL12 Exceedance
	TSRIASL12 Exceedance

Summary of Results for cis-1,2-Dichloroethene (cis-1,2-DCE)

Sample Type	Sample ID	Measured Concentration ($\mu\text{g}/\text{m}^3$)							
		May 2017	Sep. 2017	Feb. 2018	Aug. 2018	Nov. 2018	Feb. 2019	Apr. 2019	Aug. 2019
		E1	E2	E3	E4	E5	E6	E7	E8
Outdoor Air	941-OA-01	<0.13	<0.14	<0.13	<0.13	<0.12	<0.14	<0.13	<0.14
Indoor Air	941-IA-01	<0.12	0.42	<0.13	<0.13	<0.14	<0.14	<0.13	<0.14
	941-IA-02	<0.13	<0.13	0.14	<0.14	0.21	0.41	<0.67	0.26
	941-IA-03	<0.13	<0.14	<0.14	<0.14	<0.14	<0.13	<0.32	0.20
	941-IA-04	0.13	0.23	22	<0.13	27	2.6	1.6	3.9
	941-IA-05	<0.13	<0.12	<0.12	<0.14	0.22	0.17	<0.68	0.19
	941-IA-06	<0.13	0.15	1.1	<0.13	3.2	0.59	<0.66	0.55
	941-IA-07	<0.13	<0.13	0.92	<0.13	1	0.64	<0.44	0.36
	941-IA-08	<0.13	<0.14	0.90	<0.13	0.73	0.86	<0.62	0.36
	941-IA-09	<0.13	<0.13	0.34	<0.14	1.5	0.64	<1.1	0.39
Sub-Slab Soil Gas	941-SS-01	<3.5	14	<4.2	<7.4	6.2	<3.1	7.9	12
	941-SS-02	<170	240	88	110	<110	<320	<8,000	<150
	941-SS-03	27	12	20	17	14	9.5	28	40
	941-SS-04	9,300	9,100	10,000	12,000	7,000	9,200	9,400	6,700
	941-SS-05	210	310	270	280	300	220	160	220
	941-SS-06	20	28	51	34	86	66	68	97
	941-IA-07	<3.4	<4.1	5.2	<3	4.9	<3.1	3.9	<3
	941-IA-08	<8	<13	<5.2	<12	<3.2	<3.2	<3.1	<9.8
	941-IA-09	40	62	24	120	99	<3.2	200	230

Screening levels for indoor air are $24 \mu\text{g}/\text{m}^3$ (RIASL₁₂) and $72 \mu\text{g}/\text{m}^3$ (TSRIASL₁₂)
Screening levels for soil-gas are $820 \mu\text{g}/\text{m}^3$ (RIASL₁₂) and $2,500 \mu\text{g}/\text{m}^3$ (TSRIASL₁₂)

Summary of Results for Naphthalene

Sample Type	Sample ID	Measured Concentration ($\mu\text{g}/\text{m}^3$)							
		May 2017	Sep. 2017	Feb. 2018	Aug. 2018	Nov. 2018	Feb. 2019	Apr. 2019	Aug. 2019
		E1	E2	E3	E4	E5	E6	E7	E8
Outdoor Air	941-OA-01	<0.43	<0.47	<0.42	<0.44	<0.41	<0.46	<0.43	<0.45
Indoor Air	941-IA-01	<0.41	0.52	<0.43	0.57	<0.45	<0.46	<0.43	<0.46
	941-IA-02	<0.44	<0.44	<0.44	<0.45	<0.43	1.7	<2.2	<0.46
	941-IA-03	<0.43	<0.46	<0.45	0.68	<0.47	0.63	<1	<0.47
	941-IA-04	<0.43	<0.45	<4.4	<0.43	<0.94	<0.47	<2.7	<0.44
	941-IA-05	<0.44	0.47	<0.4	<0.46	<0.45	<0.44	<2.2	<0.48
	941-IA-06	<0.44	<0.44	<0.47	<0.44	<0.42	1.4	<2.2	<0.46
	941-IA-07	<0.44	<0.44	<0.48	<0.44	<0.44	2.4	<1.4	<0.46
	941-IA-08	<0.44	<0.45	<0.46	<0.44	<0.56	0.88	<2	<0.46
	941-IA-09	<0.43	<0.42	<0.48	<0.45	<0.44	1.4	<3.7	<0.42
Sub-Slab Soil Gas	941-SS-01	<9.2	<16	<11	<20	15	<8.2	<8.3	<17
	941-SS-02	<890	<360	<410	<350	<570	<1,700	<42,000	<790
	941-SS-03	<8.1	<8	<8.3	<8.1	<7.8	<8.2	<7.6	<8.6
	941-SS-04	<900	<560	<880	<820	<910	<780	<800	<380
	941-SS-05	<430	<330	<400	<310	<240	<310	<280	<180
	941-SS-06	<37	<53	55	39	27	<29	<27	<27
	941-IA-07	16	<11	11	<7.8	16	<8.3	11	<8.1
	941-IA-08	29	<35	130	<32	18	<8.3	<8.3	<26
	941-IA-09	14	<24	<7	<20	<8.9	<8.4	<33	<18

Screening levels for indoor air are $3.6 \mu\text{g}/\text{m}^3$ (RIASL₁₂)
Screening levels for soil-gas are $120 \mu\text{g}/\text{m}^3$ (RIASL₁₂)

	RIASL12 Exceedance
	TSRIASL12 Exceedance

Summary of Results for Tetrachloroethene (PCE)

Sample Type	Sample ID	Measured Concentration (µg/m ³)							
		May 2017	Sep. 2017	Feb. 2018	Aug. 2018	Nov. 2018	Feb. 2019	Apr. 2019	Aug. 2019
		E1	E2	E3	E4	E5	E6	E7	E8
Outdoor Air	941-OA-01	2	2.3	13	2.5	5.5	<0.24	<0.22	<0.23
Indoor Air	941-IA-01	2.1	6.5	0.91	5	2.9	0.74	1.1	2.2
	941-IA-02	2.1	5	2.9	3.8	5.2	2.2	2.9	2.5
	941-IA-03	2.1	6.2	0.44	3.6	3.6	0.77	<0.54	1.9
	941-IA-04	2.8	8	210	4.1	220	12	14	33
	941-IA-05	2.5	5.2	1.5	5.8	6.7	0.95	2.4	7.1
	941-IA-06	2.1	6.6	6.3	4.2	17	2.1	4.7	1.6
	941-IA-07	1.1	5.2	5.9	4.3	8.3	2.8	3.4	4
	941-IA-08	2.1	0.94	6	4	7	2.1	3	2.8
	941-IA-09	2.5	5.9	2.5	4.2	10	2.6	2.5	2.8
Sub-Slab Soil Gas	941-SS-01	270	2,600	1,900	2,600	1,800	840	1,400	2,500
	941-SS-02	1,400	4,600	1,100	2,400	540	1,000		900
	941-SS-03	790	600	660	1,200	780	540	650	1,500
	941-SS-04	160,000	170,000	250,000	210,000	160,000	150,000	170,000	120,000
	941-SS-05	3,500	6,300	4,900	4,100	3,900	2,500	1,700	2,300
	941-SS-06	2,400	2,900	3,100	1,900	3,200	3,500	4,300	4,300
	941-IA-07	370	450	620	88	590	110	620	230
	941-IA-08	460	560	470	290	290	58	69	380
	941-IA-09	1,100	1,800	480	2,700	1,600	120	5,200	3,600

Screening level for indoor air is 82 µg/m³ (RIASL₁₂ and TSRIASL₁₂)
Screening level for soil-gas is 2,700 µg/m³ (RIASL₁₂ and TSRIASL₁₂)

Summary of Results for Trichloroethene (TCE)

Sample Type	Sample ID	Measured Concentration (µg/m ³)							
		May 2017	Sep. 2017	Feb. 2018	Aug. 2018	Nov. 2018	Feb. 2019	Apr. 2019	Aug. 2019
		E1	E2	E3	E4	E5	E6	E7	E8
Outdoor Air	941-OA-01	<0.44	0.35	0.43	0.3	0.26	0.20	0.87	0.32
Indoor Air	941-IA-01	1	2.5	0.22	0.92	1.8	1.4	2.3	0.57
	941-IA-02	13	4.3	67	4.2	71	21	75	24
	941-IA-03	8.4	2.4	3.5	0.93	6	4.7	22	10
	941-IA-04	9.3	5.4	76	1.4	80	11	48	20
	941-IA-05	6.8	5.8	6.8	4	94	4	27	8.6
	941-IA-06	9	6.2	26	1.3	9.1	7.4	45	14
	941-IA-07	4.6	5.8	22	1.2	17	8.2	46	13
	941-IA-08	8.3	2.4	22	1.2	14	8.4	46	13
	941-IA-09	15	7.2	12	1.7	14	8.8	76	16
Sub-Slab Soil Gas	941-SS-01	25	310	200	300	220	59	150	270
	941-SS-02	52,000	84,000	60,000	48,000	19,000	34,000	150,000	32,000
	941-SS-03	220	99	140	230	190	100	130	180
	941-SS-04	65,000	45,000	83,000	63,000	56,000	44,000	53,000	41,000
	941-SS-05	43,000	73,000	77,000	58,000	62,000	34,000	21,000	30,000
	941-SS-06	350	440	580	550	1300	1,200	1,500	2,100
	941-IA-07	26	27	44	6.2	49	14	51	28
	941-IA-08	62	120	100	140	160	46	53	190
	941-IA-09	240	370	140	600	550	18	1,000	1,100

Screening levels for indoor air are 4 µg/m³ (RIASL₁₂) and 12 µg/m³ (TSRIASL₁₂)
Screening levels for soil-gas are 130 µg/m³ (RIASL₁₂) and 400 µg/m³ (TSRIASL₁₂)

	RIASL12 Exceedance
	TSRIASL12 Exceedance

Summary of Results for 1,1,1-Trichloroethane (1,1,1-TCA)

Sample Type	Sample ID	Measured Concentration ($\mu\text{g}/\text{m}^3$)							
		May 2017	Sep. 2017	Feb. 2018	Aug. 2018	Nov. 2018	Feb. 2019	Apr. 2019	Aug. 2019
		E1	E2	E3	E4	E5	E6	E7	E8
Outdoor Air	941-OA-01	<0.18	<0.19	<0.17	<0.18	<0.17	<0.19	0.21	<0.19
Indoor Air	941-IA-01	0.25	0.31	<0.18	0.3	0.5	0.45	0.49	0.46
	941-IA-02	2.2	0.54	6.7	0.32	7.3	3.3	0.43	0.43
	941-IA-03	2.2	0.39	0.54	0.26	1.1	1	3.8	1.8
	941-IA-04	1.7	0.9	8.9	0.24	9.9	1.6	<0.36	0.78
	941-IA-05	1.7	1.4	0.97	1	1.3	0.61	4	1.4
	941-IA-06	1.6	1.1	3.2	0.22	2	1.5	7.4	2.4
	941-IA-07	0.84	0.93	2.7	0.21	1.6	1.7	7.8	2.3
	941-IA-08	1.6	0.43	2.8	0.21	1.6	1.7	7.7	2.2
	941-IA-09	2.8	1.2	1.5	0.26	2.6	1.8	13	2.8
Sub-Slab Soil Gas	941-SS-01	79	1,000	360	880	410	97	290	730
	941-SS-02	5,300	12,000	9,500	3,800	2,500	4,700	26,000	4,700
	941-SS-03	200	150	170	320	230	92	110	300
	941-SS-04	12,000	4,400	6,100	5,300	6,000	4,800	9,600	4,600
	941-SS-05	11,000	11,000	3,800	8,400	4,300	2,900	3,900	3,400
	941-SS-06	200	250	540	490	850	590	680	1,000
	941-IA-07	10	23	42	6	72	6	77	55
	941-IA-08	13	100	79	170	140	23	11	390
	941-IA-09	35	39	24	54	62	<4.4	110	210

Screening levels for indoor air are 7,000 $\mu\text{g}/\text{m}^3$ (RIASL₁₂)

Screening levels for soil-gas are 230,000 $\mu\text{g}/\text{m}^3$ (RIASL₁₂)

	RIASL12 Exceedance
	TSRIASL12 Exceedance

EVALUATION OF VI DATA TRENDS

Data trends for Building 941 are discussed below for both sub-slab soil gas and indoor air. When data exhibit a narrow range of variability, it is typical practice to express the range as a percentage. When data exhibit a large range of variability, however, it is more useful to express the range in orders of magnitude (i.e., factors of 10). This can be expressed mathematically as the log of the ratio of maximum/minimum values. If the values differ by a factor of 10, the log of the ratio is 1, if the values differ by a factor of 100, the log of the ratio is 2, and so on.

The variability across all locations over all sampling events is the total variability. This encompasses different types of variability, including spatial variability (i.e., how do the results vary from location to location), temporal variability (i.e., how do the results at a given location vary over time), and measurement variability. Measurement variability can be determined by evaluating results of duplicate or collocated samples and includes both sampling variability and analytical variability. The comparison of two data values is typically expressed as a RPD. The comparison of three or more data values is typically expressed as the %CV, which is the standard deviation divided by the mean.

Sub-Slab Soil Gas Data Trends

Spatial Variability of Sub-Slab Soil Gas – The sub-slab soil gas exhibits up to four orders of magnitude of spatial variability. For example, sub-slab soil gas detections of TCE vary from 6 to 63,000 $\mu\text{g}/\text{m}^3$ (log of max./min. = 4.0) across the nine locations for E4. During that same sampling event, the range for PCE was 88 to 210,000 $\mu\text{g}/\text{m}^3$ (log of max./min. = 3.4) and the range for 1,1,1-TCA was 10 to 53,000 $\mu\text{g}/\text{m}^3$ (log of max./min. = 3.7).

Temporal Variability of Sub-Slab Soil Gas – At locations with the highest sub-slab soil gas concentrations, the temporal variability was only about a factor of two across the eight sampling events. In some cases, however, the data exhibits several orders of magnitude of temporal variability. For example, sub-slab soil gas concentrations of 1,1,1-TCA vary from 800 to 120,000 $\mu\text{g}/\text{m}^3$ at location 941-SS-02 (log max/min = 2.2) across all eight sampling events. At that same location, the range for TCE was 19,000 to 150,000 $\mu\text{g}/\text{m}^3$ (log max/min = 0.9).

Seasonal Confirmation Sampling Trend Analysis – No formal statistical tests were performed but the sub-slab soil gas data at locations with the highest concentrations generally do not exhibit any upward or downward trend over the course of the eight sampling events. This is illustrated in the graph below, which shows results for several locations with relatively high concentrations for analytes detected at the highest concentrations. Note that the y-axis is a log scale.

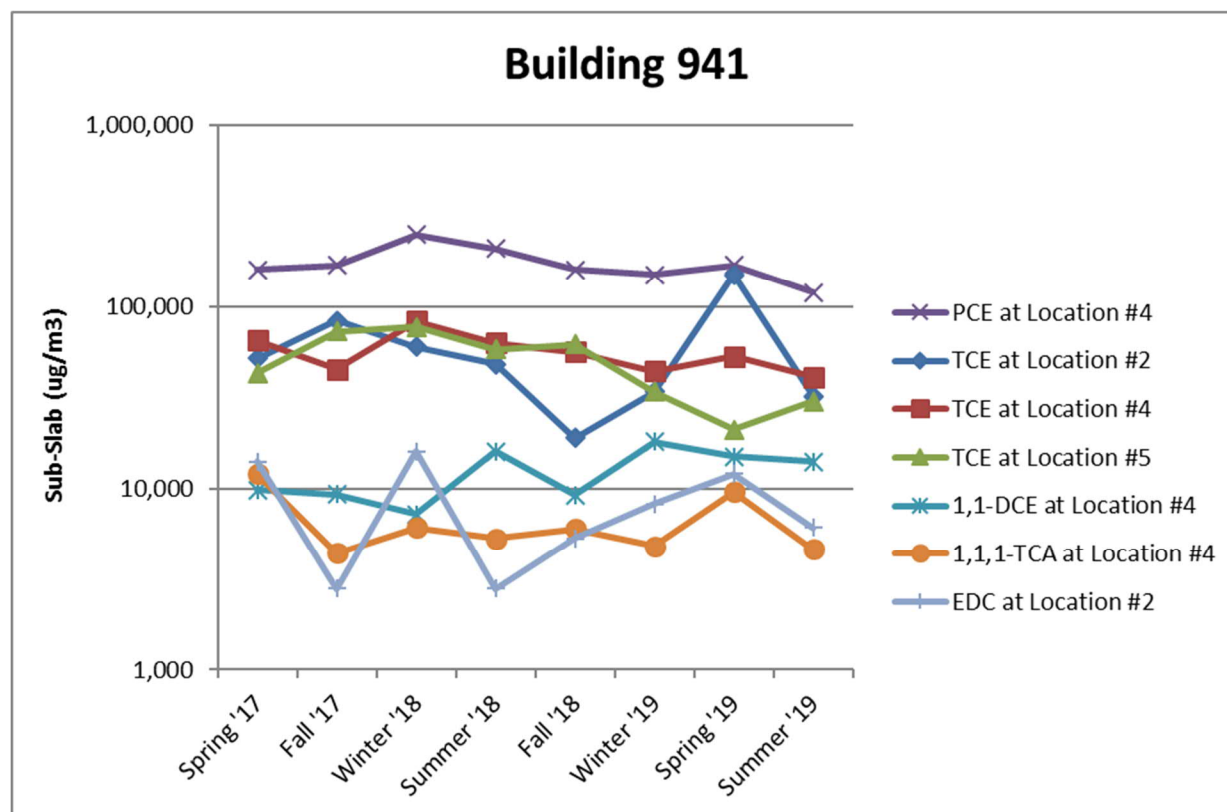

The data set was examined to see what the potential consequences would have been had only a single sampling event been performed. For the analytes present at the highest concentrations in the sub-slab soil gas (i.e., PCE and TCE), the maximum sub-slab soil gas concentration was obtained during E3 (winter) or E7 (spring). For PCE at location 941-SS-04, the value increased from 160,000 during E1 to 250,000 during E3. If only the first sampling event had been performed, a negative bias of 56% would have been introduced (i.e., the PCE value for E3 was 56% higher than the PCE value for E1).

Indoor Air Data Trends

Spatial Variability of Indoor Air – The indoor air exhibits one to two orders of magnitude of spatial variability. For example, PCE was detected in all nine indoor air samples and varied from 2.9 to 220 $\mu\text{g}/\text{m}^3$ during E5 (log max./min. = 1.9). PCE had about one order of magnitude or less for six of the eight sampling events.

Temporal Variability of Indoor Air – The detected values for PCE and TCE exhibit temporal variability of about two orders of magnitude over time. For example, PCE was detected during all eight sampling events at location 941-IA-04 and the values ranged from 2.8 to 220 $\mu\text{g}/\text{m}^3$. For TCE, the variability over time was similar to that for PCE. For example, TCE was detected during all eight sampling events at location 941-IA-04, with values ranging from 1.4 to 80 $\mu\text{g}/\text{m}^3$.

Additional Analyses

Comparison of Sub-Slab Soil Gas and Indoor Air Data Sets – As expected, the sub-slab soil gas data exhibit greater spatial variability than the indoor air data set. Also as expected, the sub-slab soil gas data had lower temporal variability than the indoor air data.

Seasonal Effects – The highest indoor air concentration for PCE and TCE were measured in the winter and spring. The data indicate that wintertime “stack effects” across the slab are not significant compared with other seasons of the year.

Comparison of Attenuation Factors by Event – Attenuation factors were calculated based on maximum values and are shown in Table 941-1. The values in Table 1 have not been corrected for any contribution from outdoor air.

Table 941-1. Calculated Attenuation Factors

	E1	E2	E3	E4	E5	E6	E7	E8
Evaluation Based on Maximum Detected Value								
PCE	1.8E-05	4.7E-05	8.4E-04	2.8E-05	1.4E-03	8.0E-05	8.2E-05	2.8E-04
TCE	2.3E-04	8.6E-05	9.2E-04	6.7E-05	1.5E-03	4.8E-04	5.1E-04	5.9E-04
EDC	1.7E-04	2.0E-04	8.8E-04	3.0E-04	2.3E-03	3.5E-04	1.8E-03	5.9E-04
1,1,2-TCA	1.5E-04	1.1E-04	1.5E-03	9.6E-05	2.4E-03	NC	1.5E-03	7.9E-04
1,1-DCE	2.0E-04	1.2E-04	1.9E-03	6.6E-05	2.6E-03	4.5E-04	2.6E-04	2.3E-04
Chloroform	3.1E-04	5.3E-04	1.0E-03	1.7E-04	1.6E-03	6.2E-04	3.3E-03	7.3E-04
1,1,1-TCA	2.3E-04	1.2E-04	9.4E-04	1.2E-04	1.7E-03	6.9E-04	5.0E-04	6.0E-04

NC - Not calculated due to no detections in soil gas during that round of testing.

The tabulated attenuation factors generally are consistent except that PCE tends to show greater attenuation. This may be due to the spatial variability of PCE versus the other compounds (i.e., PCE was primarily detected at 941-SS-04 whereas TCE was primarily detected at 941-SS-02, 941-SS-04, and 941-SS-05). Any of the other analytes could be used, but the best conservative estimates of a building-specific attenuation factor for Building 941 are assumed to be the values for TCE for each sampling event.

Temporal Variability in Attenuation Factor – As shown in Table 1, there was slightly more than one order of magnitude in temporal variability in the calculated attenuation factors observed in the data set, with E5 having the least attenuation and E4 generally having the greatest attenuation. The E7 and E8 sampling events occurred after joint seams were identified and sealed as points of entry for vapors. As illustrated in the figure below that plots the inverse attenuation factor for various analytes for each sampling event, interim actions taken to date have not had the desired effects. Taller columns denote greater attenuation (i.e. less VI), so the height of the last two sampling events versus the earlier sampling events provides an indication of the effectiveness of interim actions.

Assuming VI was the only source of these analytes in indoor air, all of the columns per event would be expected to have about the same height. Shorter columns potentially represent greater contribution from indoor workplace chemical use or outdoor sources for a given analyte.

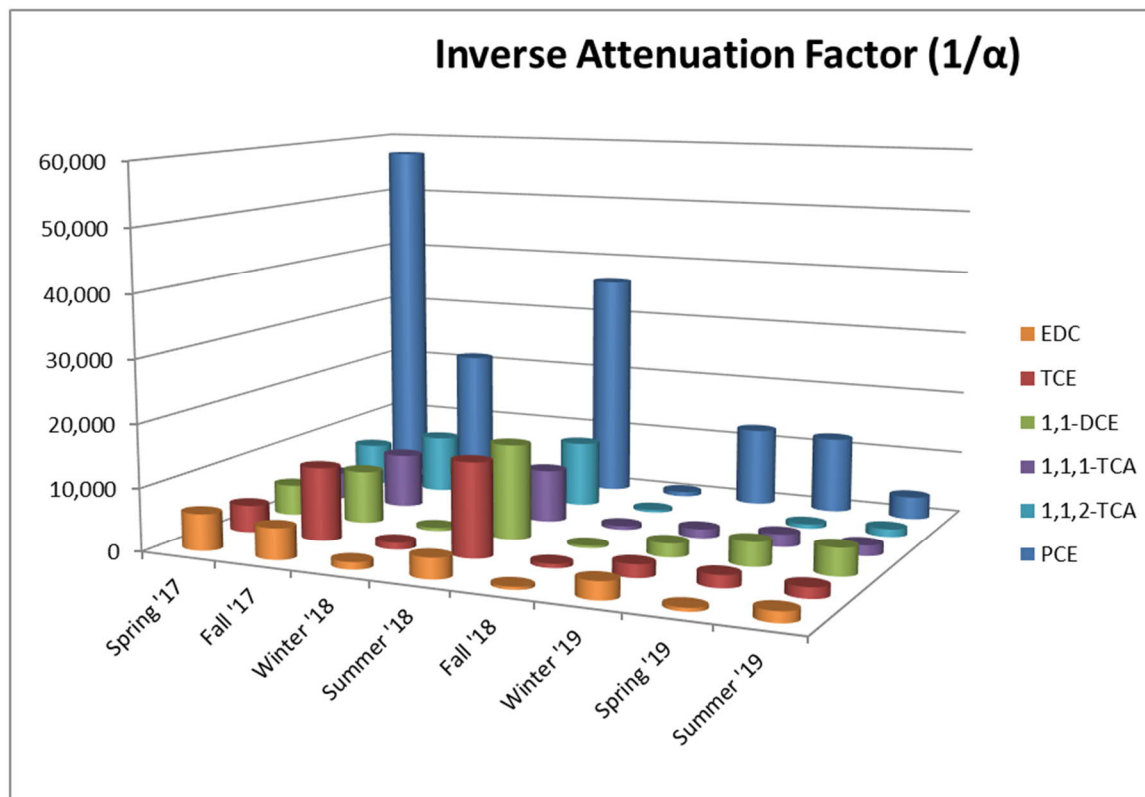

NON-DETECT EVALUATION

There were several potential exceedances noted where the analyte was ND in indoor air and/or soil gas due to the RLs of the analytical laboratory exceeding the screening level. The most significant were for HCBd, EDB, and 1,24-TCB. There have been similar issues with those same analytes at other buildings. For all three analytes, estimated indoor air concentrations are provided in the tables below.

Several soil gas samples for 1,1,2-TCA at 941-SS-04 had RLs above the $RIASL_{12}$ but no further evaluation is needed given the numerous exceedances of both the indoor air and soil gas $RIASL_{12}$. Similarly, there were a few samples for bromodichloromethane, bromomethane, and cis-1,2-DCE where the samples were diluted to get other large peaks into the range of the calibration standards and this resulted in RLs above the $RIASL_{12}$ but reviewing the entire data set indicates that there is little likelihood of concentrations actually exceeding screening levels. Naphthalene generally was ND in both indoor air and soil gas.

There are two indoor air ND RL exceedances of the $RIASL_{12}$ that merit further discussion. During E7, bromodichloromethane was $< 6.9 \mu\text{g}/\text{m}^3$ at 941-IA-05 which is just slightly above the screening level of $6.2 \mu\text{g}/\text{m}^3$. The soil gas value at that location during E7 was $140 \mu\text{g}/\text{m}^3$ and the best estimate of building attenuation for E7 is $5.1\text{E-}04$. So, the estimated indoor air concentration is $0.07 \mu\text{g}/\text{m}^3$ (i.e., 140×0.00051). Furthermore, it is noted that all 72 indoor air samples from Building 941 were ND for this compound.

During E7, naphthalene was $< 3.7 \mu\text{g}/\text{m}^3$ at 941-IA-09 which is just slightly above the screening level of $3.6 \mu\text{g}/\text{m}^3$. The soil gas value at that location during E7 was $< 33 \mu\text{g}/\text{m}^3$ and the best estimate of building attenuation for E7 is $5.1\text{E-}04$. So, the estimated indoor air concentration is $< 0.02 \mu\text{g}/\text{m}^3$ (i.e., $< 33 \times 0.00051$). Furthermore, it is noted that all indoor air samples from Building 941 were ND for naphthalene during E7.

As shown in Tables 941-2, 941-3 and 941-4, the ND evaluation demonstrates that the estimated indoor air concentrations for HCBd, EDB, and 1,2,4-TCB attributable to VI generally are below their respective draft project-specific RIASL₁₂ for all eight sampling events based on the maximum detected values and, for EDB, based on the ND RL for certain sub-slab soil gas samples.

A summary of all VI data trends and findings is presented in Table 941-5.

Table 941-2. Evaluation of Estimated Indoor Air Concentrations for HCBd

	E1	E2	E3	E4	E5	E6	E7	E8
Evaluation Based on Maximum Detection Limit								
Maximum Detection Limit of HCBd in Sub-Slab Soil Gas ($\mu\text{g}/\text{m}^3$)	<1,800	<1,100	<1,800	<1,700	<1,800	<3,400	<86,000	<1,600
Building-specific attenuation factor	2.3E-04	8.6E-05	9.2E-04	6.7E-05	1.5E-03	4.8E-04	5.1E-04	5.9E-04
Predicted Indoor Air Impacts ($\mu\text{g}/\text{m}^3$) ^a	<0.41	<0.09	<1.7	<0.11	<2.7	<1.6	<44	<0.94
Exceedance of Screening Level of 5.4 $\mu\text{g}/\text{m}^3$?	No	No	No	No	No	No	Possibly	No

^a Based on the selected building-specific attenuation factor for each sampling event.

Table 941-3. Evaluation of Estimated Indoor Air Concentrations for EDB

	E1	E2	E3	E4	E5	E6	E7	E8
Evaluation Based on Maximum Detection Limit								
Maximum Detection Limit of EDB in Sub-Slab Soil Gas ($\mu\text{g}/\text{m}^3$)	<330	<200	<320	<300	<330	<610	<15,000	<290
Building-specific attenuation factor	2.3E-04	8.6E-05	9.2E-04	6.7E-05	1.5E-03	4.8E-04	5.1E-04	5.9E-04
Predicted Indoor Air Impacts ($\mu\text{g}/\text{m}^3$) ^a	<0.08	<0.02	<0.29	<0.02	<0.50	<0.29	<7.6	<0.17
Exceedance of Screening Level of 0.2 $\mu\text{g}/\text{m}^3$?	No	No	Possibly	No	Possibly	Possibly	Possibly	No

^a Based on the selected building-specific attenuation factor for each sampling event.

Table 941-4. Evaluation of Estimated Indoor Air Concentrations for 1,2,4-TCB

	E1	E2	E3	E4	E5	E6	E7	E8
Evaluation Based on Maximum Detection Limit								
Maximum Detection Limit of 1,2,4-TCB in Sub-Slab Soil Gas ($\mu\text{g}/\text{m}^3$)	<1,300	<800	<1,200	<1,200	<1,300	<2,400	<60,000	<1,100
Building-specific attenuation factor	2.3E-04	8.6E-05	9.2E-04	6.7E-05	1.5E-03	4.8E-04	5.1E-04	5.9E-04
Predicted Indoor Air Impacts ($\mu\text{g}/\text{m}^3$) ^a	<0.30	<0.07	<1.1	<0.08	<1.95	<1.1	<31	<0.65
Exceedance of Screening Level of 2.1 $\mu\text{g}/\text{m}^3$?	No	No	No	No	No	No	Possibly	No

^a Based on the selected building-specific attenuation factor for each sampling event.

Table 941-5. Summary of Findings of Seasonal Confirmation Sampling

Topic	Finding	Details
Spatial Variability of Soil Gas	Four orders of magnitude or less	TCE during E4 ranged from 6 to 63,000 $\mu\text{g}/\text{m}^3$, log max./min. = 4.0 PCE during E4 ranged from 88 to 210,000 $\mu\text{g}/\text{m}^3$, log max./min. = 3.4
Temporal Variability of Soil Gas	A factor of two for the locations with relatively high concentrations	PCE at location 941-SS-04 ranged from 150,000 to 250,000 $\mu\text{g}/\text{m}^3$, log max./min. = 0.2 Up to two orders of magnitude variability observed for some other analytes
Seasonal Trend Analysis	Seasonal sampling is appropriate	No observed seasonal dependence and no upward or downward trend in concentration
Spatial Variability of Indoor Air	Two orders of magnitude or less	PCE during E5 ranged from 2.9 to 220 $\mu\text{g}/\text{m}^3$, log max./min. = 1.9
Temporal Variability of Indoor Air	Two orders of magnitude	PCE at location 941-SS-04 ranged from 2.8 to 220 $\mu\text{g}/\text{m}^3$, log max./min. = 1.9
Comparison of Sub-Slab Soil Gas vs. Indoor Air	Data show the expected trends for spatial variability. Less temporal variability in indoor air than expected.	Spatial variability: sub-slab soil gas greater than indoor air Temporal variability: sub-slab soil gas greater than indoor air
Best Estimate of Attenuation Factor	Varies from event to event	Most defensible values are based on 1,1-DCE and PCE data. Values vary from a minimum of 1.58E-05 and a maximum of 4.6E-04
Temporal Variability in Attenuation Factor	Wintertime (E3) had the lowest attenuation	All calculated attenuation factors fall within two orders of magnitude
Overall Summary	Possible increase in impacts during wintertime sampling	Winter sampling events had highest sub-slab soil gas concentrations of TCE and PCE, and summer events for cis-1,2-DCE Fall events had highest indoor air concentrations of PCE, TCE, and cis-1,2-DCE

SUMMARY AND PATH FORWARD

Building 941 is confirmed as a VI Path Forward Group 4B building. Further investigation activities were conducted with a mobile GC in March and May 2019 and reported in the June 2019 Summary of Investigative Findings (see Appendix C). During these activities, it was determined that there is a preferential pathway in the women's locker room (941-xx-04) but a specific source has not been identified; however, the concentrations were not as high as would be expected if this was a preferential pathway responsible for TCE concentrations throughout the building. Results from the conference room (941-xx-02) over- and under-pressurizing confirmed any source for TCE concentrations is outside the conference room. Joint seams were identified immediately outside the conference room and around the perimeter of the glass cleaning shop and confirmed as a source of VI. Additionally, the field crew noted that Building 941 was under negative pressure relative to the outside air. Ideally, the building should be under positive pressure to minimize vapor transport across the building slab.

Dow implemented an interim action to seal the joint seams and this activity was completed on April 11, 2019; however, as discussed in the July 2019 Corrective Action status meeting, the sealed joint seams are not providing a significant reduction in indoor air results. The air purifiers with carbon impregnated filters continue to be utilized and maintained in the women's locker room (941-xx-04) and the conference room (941-xx-02). This is a temporary measure being used until the vapor pathway is controlled or mitigated at these locations. Based on these results, although sealing the joint seams has reduced the levels of VI, further actions are warranted. Portions of the building floor slab in the areas impacted by VI should be sealed (Retro-Coat), potentially in conjunction with other mitigation steps, including evaluation of the heating, ventilation, and air conditioning (HVAC) system in the building. A quarterly interim monitoring plan will be implemented for Building 941 until mitigation steps have addressed the issue and is discussed further below.

Building-Specific Interim Monitoring Plan

Dow will implement a quarterly interim monitoring plan at Building 941 until a revised program or more permanent corrective action plan is developed for the site. Indoor air and sub-slab soil gas will be monitored at all existing sampling locations, with the exception of 941-xx-07. Sample location 941-xx-07 was eliminated due to consistent sub-slab soil gas results below screening levels. Monitoring will be performed for 12 analytes: 1,1,2-TCA, 1,1-DCE, EDC, bromodichloromethane, bromomethane, carbon tetrachloride, chloroform, chloromethane, cis-1,2-DCE, naphthalene, PCE, and TCE. An outdoor air sample will also be collected at the time of each monitoring event. Interim monitoring will be performed quarterly until mitigation is complete and a new LTM plan has been implemented.

Monitoring will begin in the spring of 2020. High level email summary updates will continue to be provided to EGLE as data becomes available and evaluation is performed. Updates will be provided to EGLE in the monthly Corrective Action meetings. Results from each sampling event will be reported in the annual CAIP. Dow may propose changes to the frequency or other aspects of these interim actions based on an evaluation of the data, changes in building use or implementation of other IRAs to address the potential VI pathway.

Figure 941-1

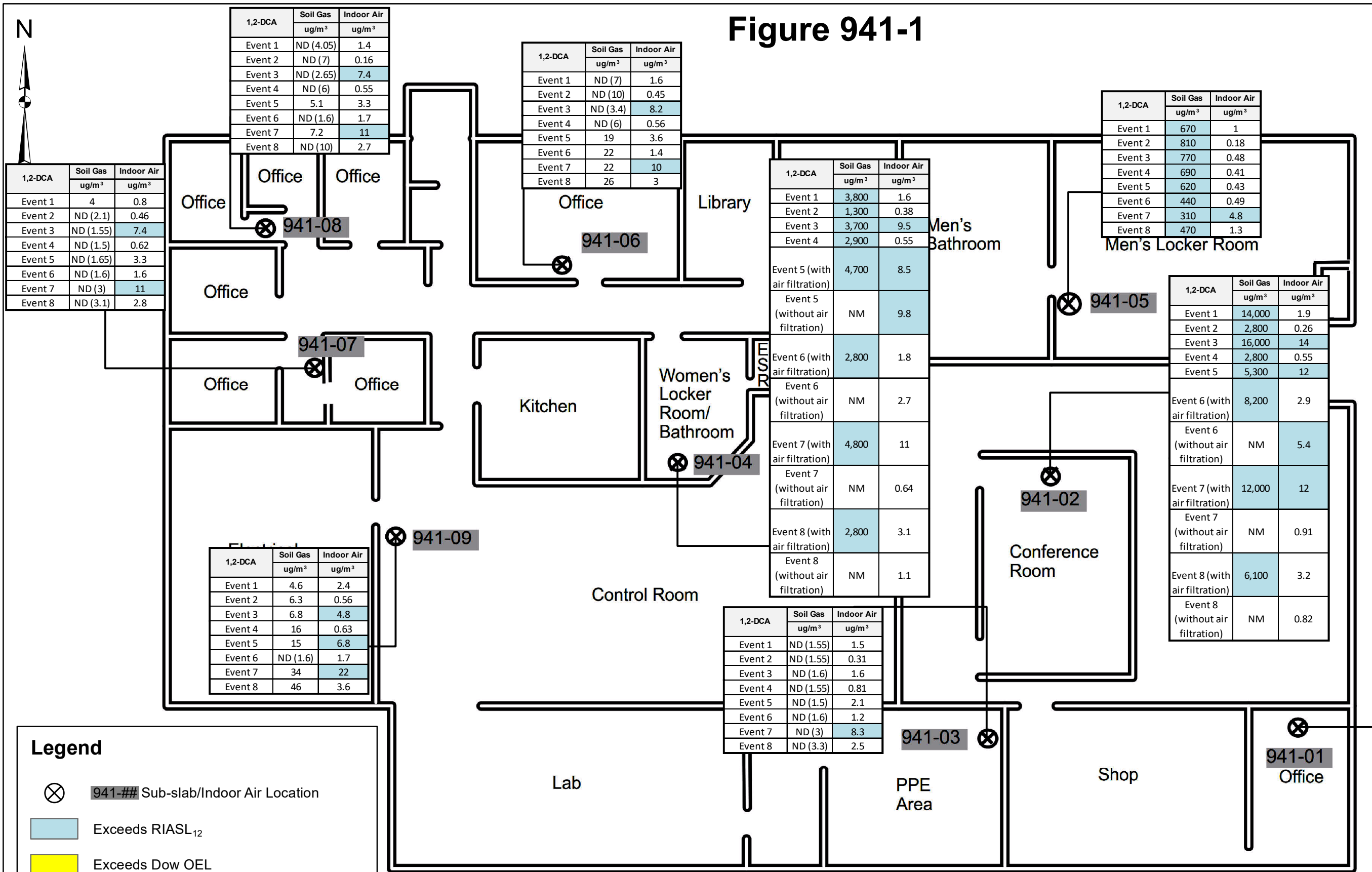

1,2-DCA	Soil Gas	Indoor Air
ug/m ³	ug/m ³	ug/m ³
Event 1	4	0.8
Event 2	ND (2.1)	0.46
Event 3	ND (1.55)	7.4
Event 4	ND (1.5)	0.62
Event 5	ND (1.65)	3.3
Event 6	ND (1.6)	1.6
Event 7	ND (3)	11
Event 8	ND (3.1)	2.8

1,2-DCA	Soil Gas	Indoor Air
ug/m ³	ug/m ³	ug/m ³
Event 1	ND (4.05)	1.4
Event 2	ND (7)	0.16
Event 3	ND (2.65)	7.4
Event 4	ND (6)	0.55
Event 5	5.1	3.3
Event 6	ND (1.6)	1.7
Event 7	7.2	11
Event 8	ND (10)	2.7

1,2-DCA	Soil Gas	Indoor Air
ug/m ³	ug/m ³	ug/m ³
Event 1	ND (7)	1.6
Event 2	ND (10)	0.45
Event 3	ND (3.4)	8.2
Event 4	ND (6)	0.56
Event 5	19	3.6
Event 6	22	1.4
Event 7	22	10
Event 8	26	3

1,2-DCA	Soil Gas	Indoor Air
ug/m ³	ug/m ³	ug/m ³
Event 1	3,800	1.6
Event 2	1,300	0.38
Event 3	3,700	9.5
Event 4	2,900	0.55
Event 5 (with air filtration)	4,700	8.5
Event 5 (without air filtration)	NM	9.8
Event 6 (with air filtration)	2,800	1.8
Event 6 (without air filtration)	NM	2.7
Event 7 (with air filtration)	4,800	11
Event 7 (without air filtration)	NM	0.64
Event 8 (with air filtration)	2,800	3.1
Event 8 (without air filtration)	NM	1.1

1,2-DCA	Soil Gas	Indoor Air
ug/m ³	ug/m ³	ug/m ³
Event 1	670	1
Event 2	810	0.18
Event 3	770	0.48
Event 4	690	0.41
Event 5	620	0.43
Event 6	440	0.49
Event 7	310	4.8
Event 8	470	1.3

1,2-DCA	Soil Gas	Indoor Air
ug/m ³	ug/m ³	ug/m ³
Event 1	14,000	1.9
Event 2	2,800	0.26
Event 3	16,000	14
Event 4	2,800	0.55
Event 5	5,300	12
Event 6 (with air filtration)	8,200	2.9
Event 6 (without air filtration)	NM	5.4
Event 7 (with air filtration)	12,000	12
Event 7 (without air filtration)	NM	0.91
Event 8 (with air filtration)	6,100	3.2
Event 8 (without air filtration)	NM	0.82

1,2-DCA	Soil Gas	Indoor Air
ug/m ³	ug/m ³	ug/m ³
Event 1	4.6	2.4
Event 2	6.3	0.56
Event 3	6.8	4.8
Event 4	16	0.63
Event 5	15	6.8
Event 6	ND (1.6)	1.7
Event 7	34	22
Event 8	46	3.6

1,2-DCA	Soil Gas	Indoor Air
ug/m ³	ug/m ³	ug/m ³
Event 1	ND (1.55)	1.5
Event 2	ND (1.55)	0.31
Event 3	ND (1.6)	1.6
Event 4	ND (1.55)	0.81
Event 5	ND (1.5)	2.1
Event 6	ND (1.6)	1.2
Event 7	ND (3)	8.3
Event 8	ND (3.3)	2.5

Notes:
 All units ug/m³
 Initial Sampling Event (1) = May 2017
 Seasonal Confirmation Sampling Event 2 = September 2017
 Seasonal Confirmation Sampling Event 3 = February 2018
 Seasonal Confirmation Sampling Event 4 = August 2018
 Seasonal Confirmation Sampling Event 5 = November 2018
 Seasonal Confirmation Sampling Event 6 = February 2019
 Seasonal Confirmation Sampling Event 7 = April 2019
 Seasonal Confirmation Sampling Event 8 = August 2019

Outdoor air location placed near intake located at NE corner of building.

1,2-DCA	Outdoor Air Sample
ug/m ³	ug/m ³
Event 1	0.54
Event 2	ND (0.07)
Event 3	0.24
Event 4	0.2
Event 5	0.18
Event 6	ND (0.07)
Event 7	0.31
Event 8	ND (0.14)

Legend

- ⊗ 941-## Sub-slab/Indoor Air Location
- Exceeds RIASL₁₂
- Exceeds Dow OEL

Media	COC	RIASL ₁₂	TSRIASL ₁₂	OEL
Soil Gas	1,2-DCA	150	--	--
Indoor Air	1,2-DCA	4.6	--	4,050

1,2-DCA	Soil Gas	Indoor Air
ug/m ³	ug/m ³	ug/m ³
Event 1	ND (1.8)	0.76
Event 2	ND (3.2)	0.26
Event 3	ND (2.15)	0.3
Event 4	ND (3.75)	0.88
Event 5	ND (1.6)	1
Event 6	ND (1.6)	0.45
Event 7	ND (3.2)	0.86
Event 8	ND (6.4)	0.4

Sub-slab Soil Gas and Indoor Air Results for 1,2-Dichloroethane Zone 2 Phase 1 Sampling Events 1 - 8 Building 941

Figure 941-2

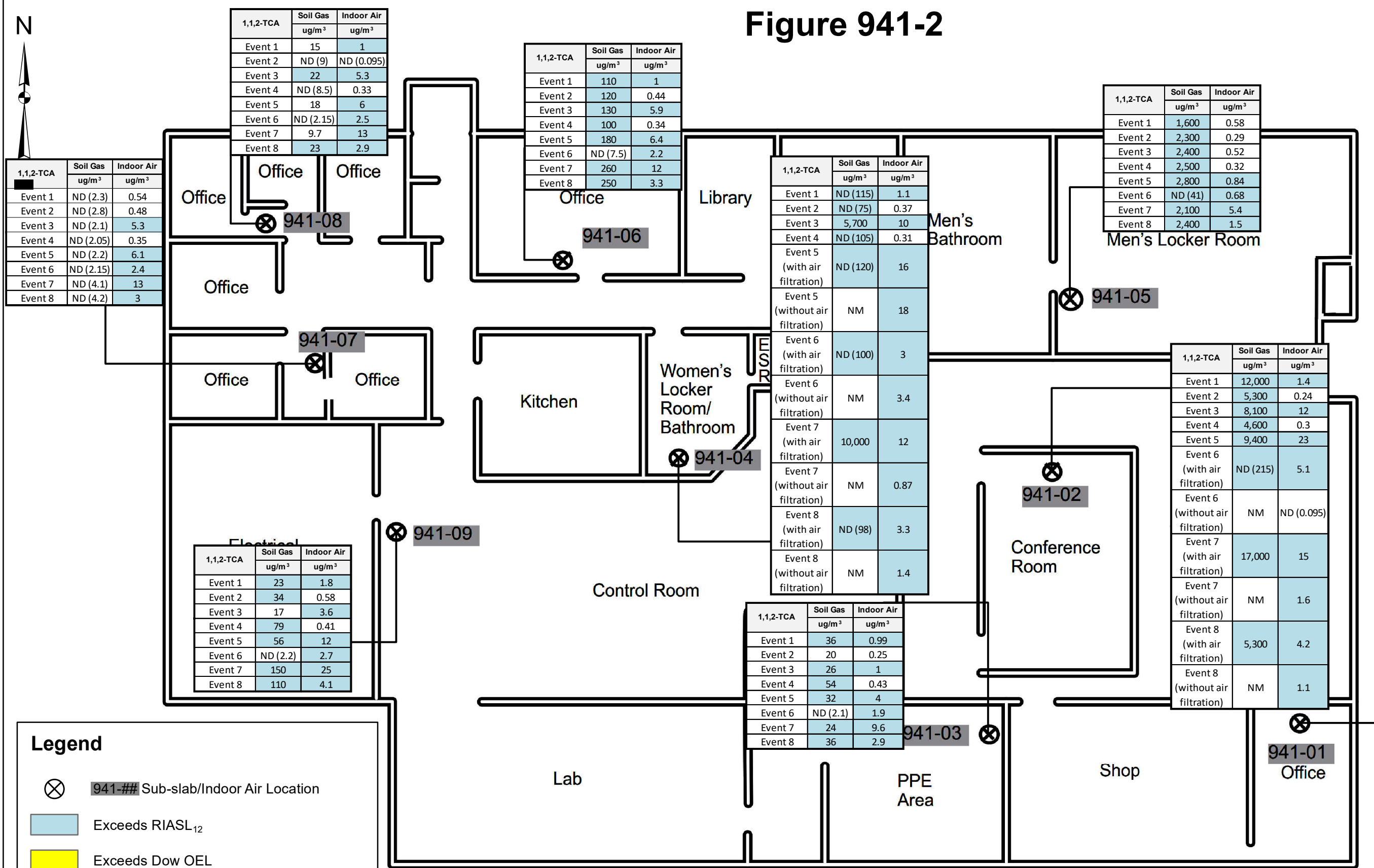

1,1,2-TCA	Soil Gas	Indoor Air
ug/m ³	ug/m ³	ug/m ³
Event 1	ND (2.3)	0.54
Event 2	ND (2.8)	0.48
Event 3	ND (2.1)	5.3
Event 4	ND (2.05)	0.35
Event 5	ND (2.2)	6.1
Event 6	ND (2.15)	2.4
Event 7	ND (4.1)	13
Event 8	ND (4.2)	3

1,1,2-TCA	Soil Gas	Indoor Air
ug/m ³	ug/m ³	ug/m ³
Event 1	15	1
Event 2	ND (9)	ND (0.095)
Event 3	22	5.3
Event 4	ND (8.5)	0.33
Event 5	18	6
Event 6	ND (2.15)	2.5
Event 7	9.7	13
Event 8	23	2.9

1,1,2-TCA	Soil Gas	Indoor Air
ug/m ³	ug/m ³	ug/m ³
Event 1	110	1
Event 2	120	0.44
Event 3	130	5.9
Event 4	100	0.34
Event 5	180	6.4
Event 6	ND (7.5)	2.2
Event 7	260	12
Event 8	250	3.3

1,1,2-TCA	Soil Gas	Indoor Air
ug/m ³	ug/m ³	ug/m ³
Event 1	ND (115)	1.1
Event 2	ND (75)	0.37
Event 3	5,700	10
Event 4	ND (105)	0.31
Event 5 (with air filtration)	ND (120)	16
Event 5 (without air filtration)	NM	18
Event 6 (with air filtration)	ND (100)	3
Event 6 (without air filtration)	NM	3.4
Event 7 (with air filtration)	10,000	12
Event 7 (without air filtration)	NM	0.87
Event 8 (with air filtration)	ND (98)	3.3
Event 8 (without air filtration)	NM	1.4

1,1,2-TCA	Soil Gas	Indoor Air
ug/m ³	ug/m ³	ug/m ³
Event 1	1,600	0.58
Event 2	2,300	0.29
Event 3	2,400	0.52
Event 4	2,500	0.32
Event 5	2,800	0.84
Event 6	ND (41)	0.68
Event 7	2,100	5.4
Event 8	2,400	1.5

1,1,2-TCA	Soil Gas	Indoor Air
ug/m ³	ug/m ³	ug/m ³
Event 1	23	1.8
Event 2	34	0.58
Event 3	17	3.6
Event 4	79	0.41
Event 5	56	12
Event 6	ND (2.2)	2.7
Event 7	150	25
Event 8	110	4.1

1,1,2-TCA	Soil Gas	Indoor Air
ug/m ³	ug/m ³	ug/m ³
Event 1	36	0.99
Event 2	20	0.25
Event 3	26	1
Event 4	54	0.43
Event 5	32	4
Event 6	ND (2.1)	1.9
Event 7	24	9.6
Event 8	36	2.9

1,1,2-TCA	Soil Gas	Indoor Air
ug/m ³	ug/m ³	ug/m ³
Event 1	12,000	1.4
Event 2	5,300	0.24
Event 3	8,100	12
Event 4	4,600	0.3
Event 5	9,400	23
Event 6 (with air filtration)	ND (215)	5.1
Event 6 (without air filtration)	NM	ND (0.095)
Event 7 (with air filtration)	17,000	15
Event 7 (without air filtration)	NM	1.6
Event 8 (with air filtration)	5,300	4.2
Event 8 (without air filtration)	NM	1.1

Notes:
 All units ug/m3
 Initial Sampling Event (1) = May 2017
 Seasonal Confirmation Sampling Event 2 = September 2017
 Seasonal Confirmation Sampling Event 3 = February 2018
 Seasonal Confirmation Sampling Event 4 = August 2018
 Seasonal Confirmation Sampling Event 5 = November 2018
 Seasonal Confirmation Sampling Event 6 = February 2019
 Seasonal Confirmation Sampling Event 7 = April 2019
 Seasonal Confirmation Sampling Event 8 = August 2019
 Outdoor air location placed near intake located at NE corner of building.

1,1,2-TCA	Outdoor Air Sample
ug/m ³	ug/m ³
Event 1	ND (0.09)
Event 2	ND (0.095)
Event 3	ND (0.085)
Event 4	ND (0.09)
Event 5	ND (0.085)
Event 6	ND (0.095)
Event 7	0.21
Event 8	ND (0.19)

Legend

- ⊗ 941-## Sub-slab/Indoor Air Location
- Exceeds RIASL₁₂
- Exceeds Dow OEL

Media	COC	RIASL ₁₂	TSRIASL ₁₂	OEL
Soil Gas	1,1,2-TCA	20	--	--
Indoor Air	1,1,2-TCA	0.62	--	54,600

1,1,2-TCA	Soil Gas	Indoor Air
ug/m ³	ug/m ³	ug/m ³
Event 1	8.1	0.19
Event 2	25	0.24
Event 3	11	ND (0.09)
Event 4	ND (5)	0.44
Event 5	ND (2.15)	1.8
Event 6	ND (2.1)	0.71
Event 7	8.8	0.83
Event 8	ND (8.6)	0.4

Sub-slab Soil Gas and Indoor Air Results for 1,1,2-Trichloroethane Zone 2 Phase 1 Sampling Events 1 - 8 Building 941

Figure 941-3

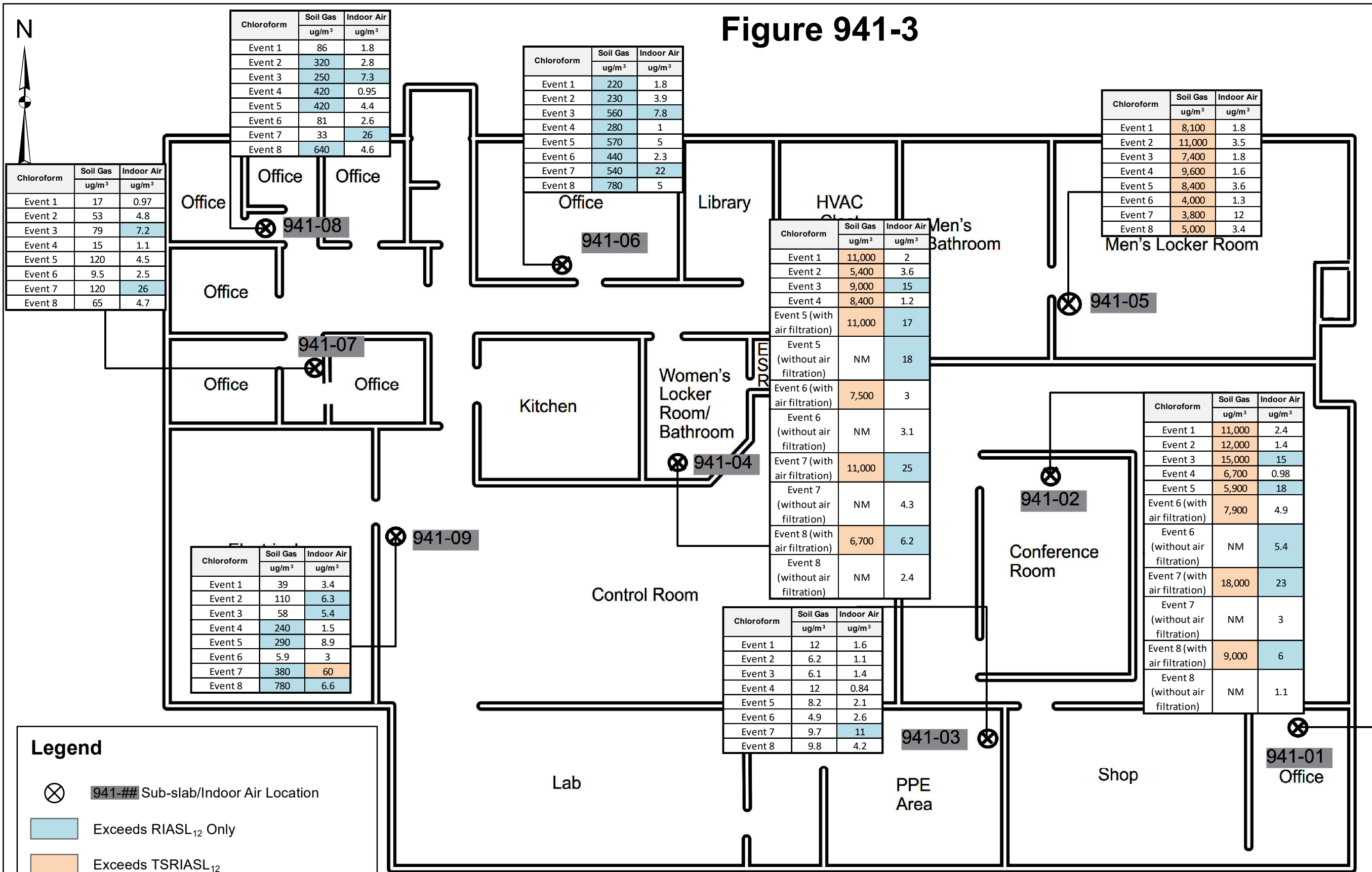

Chloroform	Soil Gas	Indoor Air
ug/m ³	ug/m ³	ug/m ³
Event 1	17	0.97
Event 2	53	4.8
Event 3	79	7.2
Event 4	15	1.1
Event 5	120	4.5
Event 6	9.5	2.5
Event 7	120	26
Event 8	65	4.7

Chloroform	Soil Gas	Indoor Air
ug/m ³	ug/m ³	ug/m ³
Event 1	86	1.8
Event 2	320	2.8
Event 3	250	7.3
Event 4	420	0.95
Event 5	420	4.4
Event 6	81	2.6
Event 7	33	26
Event 8	640	4.6

Chloroform	Soil Gas	Indoor Air
ug/m ³	ug/m ³	ug/m ³
Event 1	220	1.8
Event 2	230	3.9
Event 3	560	7.8
Event 4	280	1
Event 5	570	5
Event 6	440	2.3
Event 7	540	22
Event 8	780	5

Chloroform	Soil Gas	Indoor Air
ug/m ³	ug/m ³	ug/m ³
Event 1	8,100	1.8
Event 2	11,000	3.5
Event 3	7,400	1.8
Event 4	9,600	1.6
Event 5	8,400	3.6
Event 6	4,000	1.3
Event 7	3,800	12
Event 8	5,000	3.4

Chloroform	Soil Gas	Indoor Air
ug/m ³	ug/m ³	ug/m ³
Event 1	11,000	2
Event 2	5,400	3.6
Event 3	9,000	15
Event 4	8,400	1.2
Event 5 (with air filtration)	11,000	17
Event 5 (without air filtration)	NM	18
Event 6 (with air filtration)	7,500	3
Event 6 (without air filtration)	NM	3.1
Event 7 (with air filtration)	11,000	25
Event 7 (without air filtration)	NM	4.3
Event 8 (with air filtration)	6,700	6.2
Event 8 (without air filtration)	NM	2.4

Chloroform	Soil Gas	Indoor Air
ug/m ³	ug/m ³	ug/m ³
Event 1	11,000	2.4
Event 2	12,000	1.4
Event 3	15,000	15
Event 4	6,700	0.98
Event 5	5,900	18
Event 6 (with air filtration)	7,900	4.9
Event 6 (without air filtration)	NM	5.4
Event 7 (with air filtration)	18,000	23
Event 7 (without air filtration)	NM	3
Event 8 (with air filtration)	9,000	6
Event 8 (without air filtration)	NM	1.1

Chloroform	Soil Gas	Indoor Air
ug/m ³	ug/m ³	ug/m ³
Event 1	39	3.4
Event 2	110	6.3
Event 3	58	5.4
Event 4	240	1.5
Event 5	290	8.9
Event 6	5.9	3
Event 7	380	60
Event 8	780	6.6

Chloroform	Soil Gas	Indoor Air
ug/m ³	ug/m ³	ug/m ³
Event 1	12	1.6
Event 2	6.2	1.1
Event 3	6.1	1.4
Event 4	12	0.84
Event 5	8.2	2.1
Event 6	4.9	2.6
Event 7	9.7	11
Event 8	9.8	4.2

Legend

- 941-### Sub-slab/Indoor Air Location
- Exceeds RIASL₁₂ Only
- Exceeds TSRIASL₁₂
- Exceeds Dow OEL

Media	COC	RIASL ₁₂	TSRIASL ₁₂	OEL
Soil Gas	Chloroform	170	1,700	--
Indoor Air	Chloroform	5.2	52	9,760

Notes:

- All units ug/m³
- Initial Sampling Event (1) = May 2017
- Seasonal Confirmation Sampling Event 2 = September 2017
- Seasonal Confirmation Sampling Event 3 = February 2018
- Seasonal Confirmation Sampling Event 4 = August 2018
- Seasonal Confirmation Sampling Event 5 = November 2018
- Seasonal Confirmation Sampling Event 6 = February 2019
- Seasonal Confirmation Sampling Event 7 = April 2019
- Seasonal Confirmation Sampling Event 8 = August 2019
- Outdoor air location placed near intake located at NE corner of building.

Chloroform	Outdoor Air Sample Results
	ug/m ³
Event 1	0.18
Event 2	0.33
Event 3	0.43
Event 4	0.2
Event 5	0.22
Event 6	0.67
Event 7	0.35
Event 8	ND (0.17)

Chloroform	Soil Gas	Indoor Air
	ug/m ³	ug/m ³
Event 1	5.1	0.3
Event 2	25	0.76
Event 3	16	0.16
Event 4	33	0.85
Event 5	20	0.59
Event 6	6.2	0.66
Event 7	24	0.72
Event 8	46	0.32

Sub-slab Soil Gas and Indoor Air Results for Chloroform Zone 2 Phase 1 Sampling Events 1 - 8 Building 941

Figure 941-4

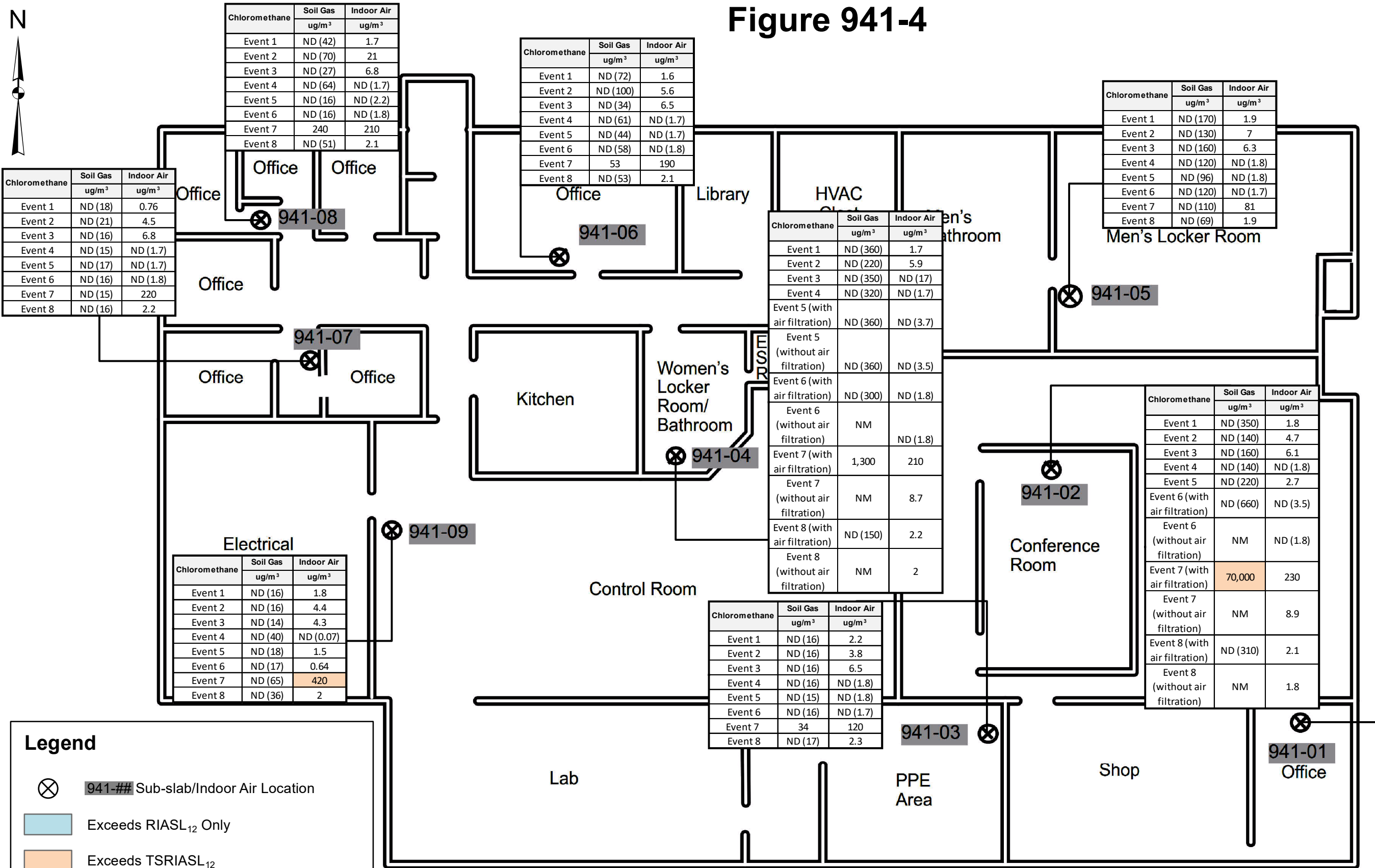

Chloromethane	Soil Gas	Indoor Air
ug/m ³	ug/m ³	ug/m ³
Event 1	ND (18)	0.76
Event 2	ND (21)	4.5
Event 3	ND (16)	6.8
Event 4	ND (15)	ND (1.7)
Event 5	ND (17)	ND (1.7)
Event 6	ND (16)	ND (1.8)
Event 7	ND (15)	220
Event 8	ND (16)	2.2

Chloromethane	Soil Gas	Indoor Air
ug/m ³	ug/m ³	ug/m ³
Event 1	ND (42)	1.7
Event 2	ND (70)	21
Event 3	ND (27)	6.8
Event 4	ND (64)	ND (1.7)
Event 5	ND (16)	ND (2.2)
Event 6	ND (16)	ND (1.8)
Event 7	240	210
Event 8	ND (51)	2.1

Chloromethane	Soil Gas	Indoor Air
ug/m ³	ug/m ³	ug/m ³
Event 1	ND (72)	1.6
Event 2	ND (100)	5.6
Event 3	ND (34)	6.5
Event 4	ND (61)	ND (1.7)
Event 5	ND (44)	ND (1.7)
Event 6	ND (58)	ND (1.8)
Event 7	53	190
Event 8	ND (53)	2.1

Chloromethane	Soil Gas	Indoor Air
ug/m ³	ug/m ³	ug/m ³
Event 1	ND (170)	1.9
Event 2	ND (130)	7
Event 3	ND (160)	6.3
Event 4	ND (120)	ND (1.8)
Event 5	ND (96)	ND (1.8)
Event 6	ND (120)	ND (1.7)
Event 7	ND (110)	81
Event 8	ND (69)	1.9

Chloromethane	Soil Gas	Indoor Air
ug/m ³	ug/m ³	ug/m ³
Event 1	ND (360)	1.7
Event 2	ND (220)	5.9
Event 3	ND (350)	ND (1.7)
Event 4	ND (320)	ND (1.7)
Event 5 (with air filtration)	ND (360)	ND (3.7)
Event 5 (without air filtration)	ND (360)	ND (3.5)
Event 6 (with air filtration)	ND (300)	ND (1.8)
Event 6 (without air filtration)	NM	ND (1.8)
Event 7 (with air filtration)	1,300	210
Event 7 (without air filtration)	NM	8.7
Event 8 (with air filtration)	ND (150)	2.2
Event 8 (without air filtration)	NM	2

Chloromethane	Soil Gas	Indoor Air
ug/m ³	ug/m ³	ug/m ³
Event 1	ND (350)	1.8
Event 2	ND (140)	4.7
Event 3	ND (160)	6.1
Event 4	ND (140)	ND (1.8)
Event 5	ND (220)	2.7
Event 6 (with air filtration)	ND (660)	ND (3.5)
Event 6 (without air filtration)	NM	ND (1.8)
Event 7 (with air filtration)	70,000	230
Event 7 (without air filtration)	NM	8.9
Event 8 (with air filtration)	ND (310)	2.1
Event 8 (without air filtration)	NM	1.8

Chloromethane	Soil Gas	Indoor Air
ug/m ³	ug/m ³	ug/m ³
Event 1	ND (16)	1.8
Event 2	ND (16)	4.4
Event 3	ND (14)	4.3
Event 4	ND (40)	ND (0.07)
Event 5	ND (18)	1.5
Event 6	ND (17)	0.64
Event 7	ND (65)	420
Event 8	ND (36)	2

Chloromethane	Soil Gas	Indoor Air
ug/m ³	ug/m ³	ug/m ³
Event 1	ND (16)	2.2
Event 2	ND (16)	3.8
Event 3	ND (16)	6.5
Event 4	ND (16)	ND (1.8)
Event 5	ND (15)	ND (1.8)
Event 6	ND (16)	ND (1.7)
Event 7	34	120
Event 8	ND (17)	2.3

Notes:

All units ug/m3

Initial Sampling Event (1) = May 2017

Seasonal Confirmation Sampling Event 2 = September 2017

Seasonal Confirmation Sampling Event 3 = February 2018

Seasonal Confirmation Sampling Event 4 = August 2018

Seasonal Confirmation Sampling Event 5 = November 2018

Seasonal Confirmation Sampling Event 6 = February 2019

Seasonal Confirmation Sampling Event 7 = April 2019

Seasonal Confirmation Sampling Event 8 = August 2019

Outdoor air location placed near intake located at NE corner of building.

Chloromethane	Outdoor Air Sample Results
	ug/m ³
Event 1	1.7
Event 2	5.4
Event 3	ND (1.6)
Event 4	2.5J
Event 5	ND (1.6)
Event 6	ND (1.8)
Event 7	2.8
Event 8	ND (1.8)

Legend

⊗ 941-## Sub-slab/Indoor Air Location

Exceeds RIASL₁₂ Only

Exceeds TSRIASL₁₂

Exceeds Dow OEL

Media	COC	RIASL ₁₂	TSRIASL ₁₂	OEL
Soil Gas	Chloromethane	9,200	14,000	--
Indoor Air	Chloromethane	280	410	10,350

Chloromethane	Soil Gas	Indoor Air
ug/m ³	ug/m ³	ug/m ³
Event 1	ND (18)	2.3
Event 2	ND (33)	4.1
Event 3	ND (22)	5.6
Event 4	ND (38)	ND (1.8)
Event 5	ND (16)	ND (1.8)
Event 6	ND (16)	ND (1.8)
Event 7	ND (16)	4.5
Event 8	ND (33)	2

Sub-slab Soil Gas and Indoor Air Results for Chloromethane Zone 2 Phase 1 Sampling Events 1 - 8 Building 941

Figure 941-5

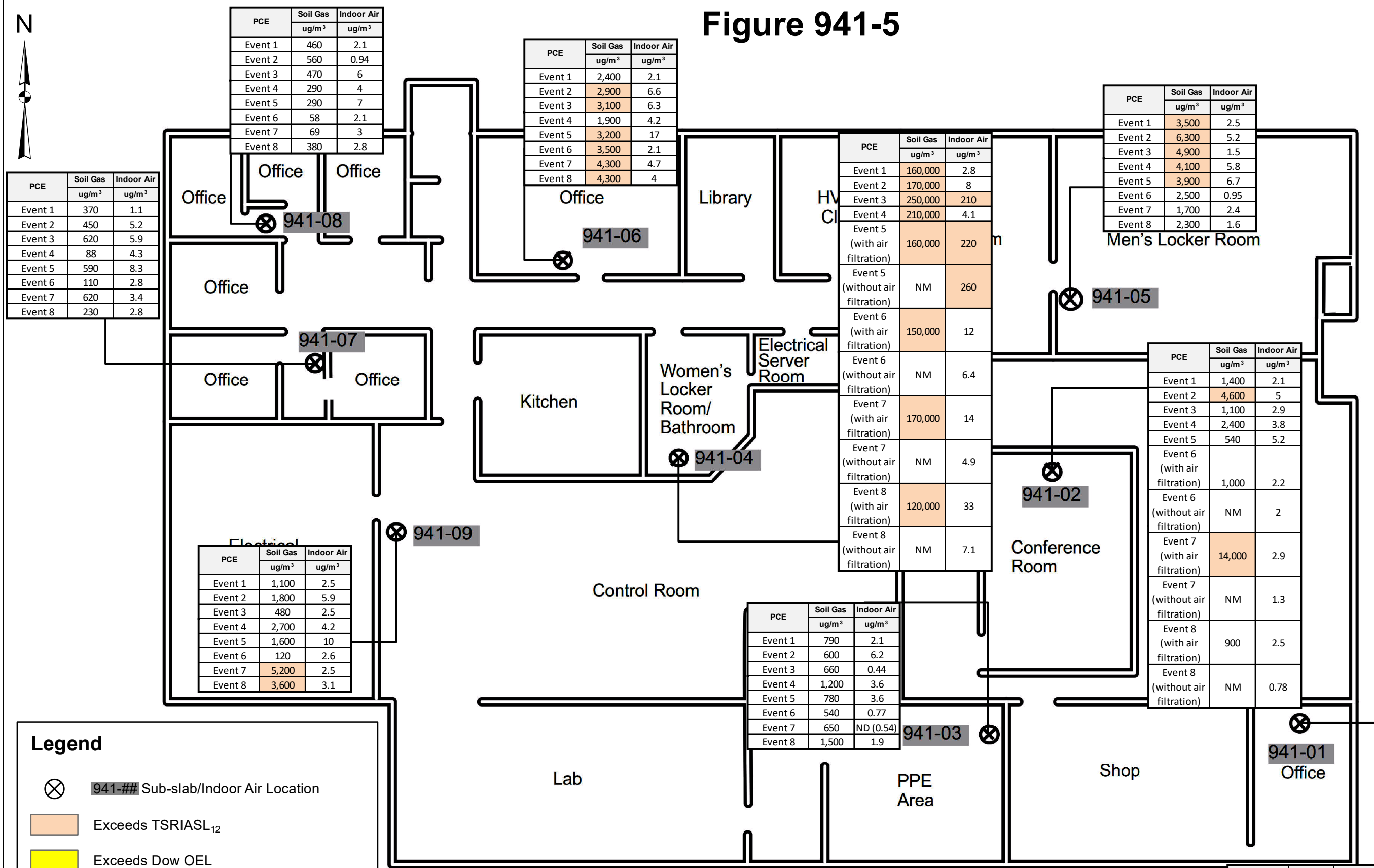

PCE	Soil Gas ug/m ³	Indoor Air ug/m ³
Event 1	370	1.1
Event 2	450	5.2
Event 3	620	5.9
Event 4	88	4.3
Event 5	590	8.3
Event 6	110	2.8
Event 7	620	3.4
Event 8	230	2.8

PCE	Soil Gas ug/m ³	Indoor Air ug/m ³
Event 1	460	2.1
Event 2	560	0.94
Event 3	470	6
Event 4	290	4
Event 5	290	7
Event 6	58	2.1
Event 7	69	3
Event 8	380	2.8

PCE	Soil Gas ug/m ³	Indoor Air ug/m ³
Event 1	2,400	2.1
Event 2	2,900	6.6
Event 3	3,100	6.3
Event 4	1,900	4.2
Event 5	3,200	17
Event 6	3,500	2.1
Event 7	4,300	4.7
Event 8	4,300	4

PCE	Soil Gas ug/m ³	Indoor Air ug/m ³
Event 1	160,000	2.8
Event 2	170,000	8
Event 3	250,000	210
Event 4	210,000	4.1

PCE	Soil Gas ug/m ³	Indoor Air ug/m ³
Event 1	3,500	2.5
Event 2	6,300	5.2
Event 3	4,900	1.5
Event 4	4,100	5.8
Event 5	3,900	6.7
Event 6	2,500	0.95
Event 7	1,700	2.4
Event 8	2,300	1.6

PCE	Soil Gas ug/m ³	Indoor Air ug/m ³
Event 1	1,400	2.1
Event 2	4,600	5
Event 3	1,100	2.9
Event 4	2,400	3.8
Event 5	540	5.2

PCE	Soil Gas ug/m ³	Indoor Air ug/m ³
Event 1	1,100	2.5
Event 2	1,800	5.9
Event 3	480	2.5
Event 4	2,700	4.2
Event 5	1,600	10
Event 6	120	2.6
Event 7	5,200	2.5
Event 8	3,600	3.1

PCE	Soil Gas ug/m ³	Indoor Air ug/m ³
Event 1	790	2.1
Event 2	600	6.2
Event 3	660	0.44
Event 4	1,200	3.6
Event 5	780	3.6
Event 6	540	0.77
Event 7	650	ND (0.54)
Event 8	1,500	1.9

PCE	Soil Gas ug/m ³	Indoor Air ug/m ³
Event 1	270	2.1
Event 2	2,600	6.5
Event 3	1,900	0.91
Event 4	2,600	5
Event 5	1,800	2.9
Event 6	840	0.74
Event 7	1,400	1.1
Event 8	2,500	2.2

Notes:

All units ug/m³

Initial Sampling Event (1) = May 2017

Seasonal Confirmation Sampling Event 2 = September 2017

Seasonal Confirmation Sampling Event 3 = February 2018

Seasonal Confirmation Sampling Event 4 = August 2018

Seasonal Confirmation Sampling Event 5 = November 2018

Seasonal Confirmation Sampling Event 6 = February 2019

Seasonal Confirmation Sampling Event 7 = April 2019

Seasonal Confirmation Sampling Event 8 = August 2019

Outdoor air location placed near intake located at NE corner of building.

PCE	Outdoor Air Sample ug/m ³
Event 1	2
Event 2	2.3
Event 3	13
Event 4	2.5
Event 5	5.5
Event 6	ND (0.12)
Event 7	ND (0.22)
Event 8	ND (0.23)

Legend

⊗ 941-## Sub-slab/Indoor Air Location

Orange box Exceeds TSRIASL₁₂

Yellow box Exceeds Dow OEL

Media	COC	RIASL ₁₂	TSRIASL ₁₂	OEL
Soil Gas	PCE	2,700	2,700	--
Indoor Air	PCE	82	82	67,800

Sub-slab Soil Gas and Indoor Air Results for Tetrachloroethene Zone 2 Phase 1 Sampling Events 1 - 8 Building 941

Figure 941-6

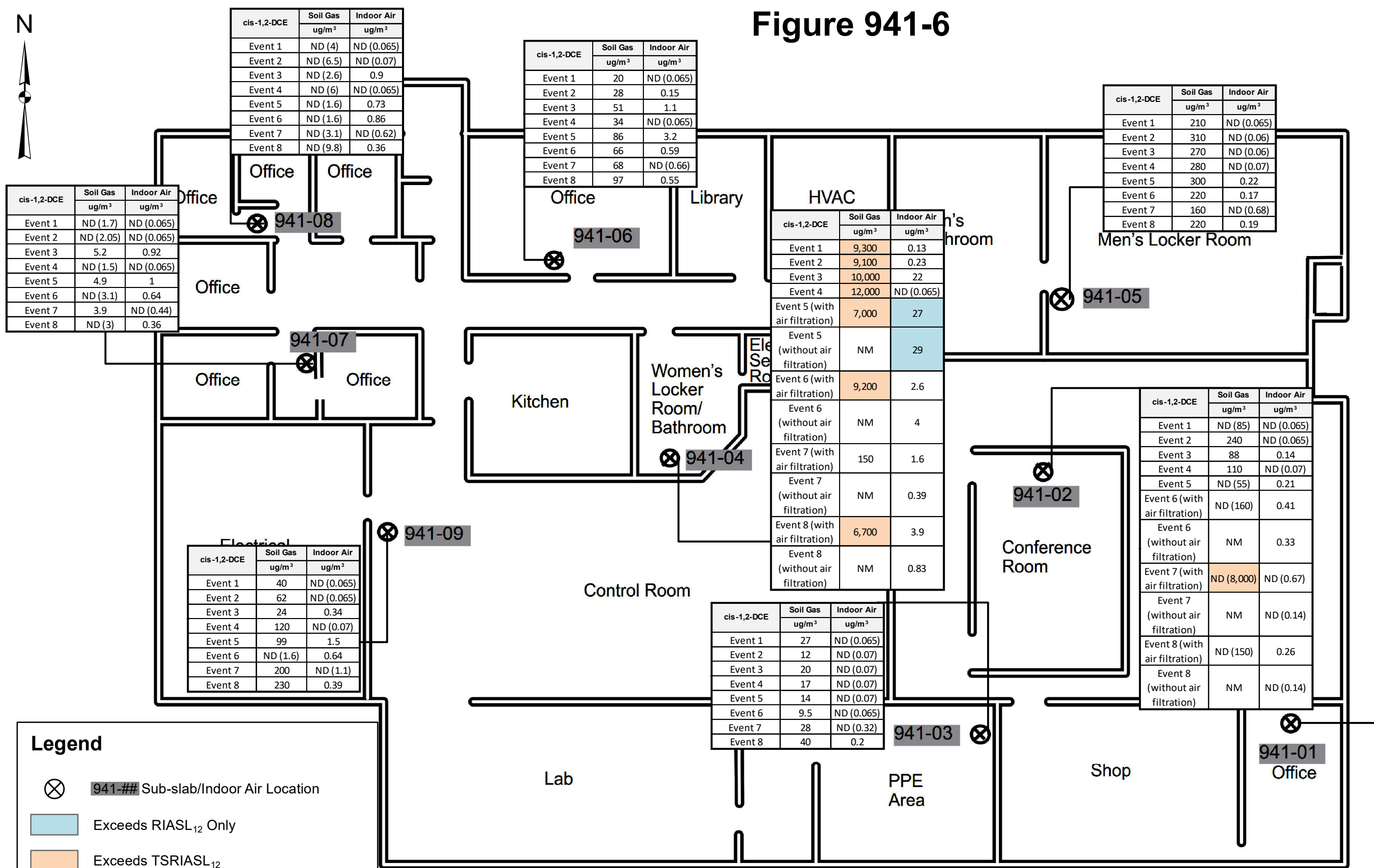

cis-1,2-DCE	Soil Gas ug/m ³	Indoor Air ug/m ³
Event 1	ND (1.7)	ND (0.065)
Event 2	ND (2.05)	ND (0.065)
Event 3	5.2	0.92
Event 4	ND (1.5)	ND (0.065)
Event 5	4.9	1
Event 6	ND (3.1)	0.64
Event 7	3.9	ND (0.44)
Event 8	ND (3)	0.36

cis-1,2-DCE	Soil Gas ug/m ³	Indoor Air ug/m ³
Event 1	ND (4)	ND (0.065)
Event 2	ND (6.5)	ND (0.07)
Event 3	ND (2.6)	0.9
Event 4	ND (6)	ND (0.065)
Event 5	ND (1.6)	0.73
Event 6	ND (1.6)	0.86
Event 7	ND (3.1)	ND (0.62)
Event 8	ND (9.8)	0.36

cis-1,2-DCE	Soil Gas ug/m ³	Indoor Air ug/m ³
Event 1	20	ND (0.065)
Event 2	28	0.15
Event 3	51	1.1
Event 4	34	ND (0.065)
Event 5	86	3.2
Event 6	66	0.59
Event 7	68	ND (0.66)
Event 8	97	0.55

cis-1,2-DCE	Soil Gas ug/m ³	Indoor Air ug/m ³
Event 1	210	ND (0.065)
Event 2	310	ND (0.06)
Event 3	270	ND (0.06)
Event 4	280	ND (0.07)
Event 5	300	0.22
Event 6	220	0.17
Event 7	160	ND (0.68)
Event 8	220	0.19

cis-1,2-DCE	Soil Gas ug/m ³	Indoor Air ug/m ³
Event 1	9,300	0.13
Event 2	9,100	0.23
Event 3	10,000	22
Event 4	12,000	ND (0.065)
Event 5 (with air filtration)	7,000	27
Event 5 (without air filtration)	NM	29
Event 6 (with air filtration)	9,200	2.6
Event 6 (without air filtration)	NM	4
Event 7 (with air filtration)	150	1.6
Event 7 (without air filtration)	NM	0.39
Event 8 (with air filtration)	6,700	3.9
Event 8 (without air filtration)	NM	0.83

cis-1,2-DCE	Soil Gas ug/m ³	Indoor Air ug/m ³
Event 1	40	ND (0.065)
Event 2	62	ND (0.065)
Event 3	24	0.34
Event 4	120	ND (0.07)
Event 5	99	1.5
Event 6	ND (1.6)	0.64
Event 7	200	ND (1.1)
Event 8	230	0.39

cis-1,2-DCE	Soil Gas ug/m ³	Indoor Air ug/m ³
Event 1	27	ND (0.065)
Event 2	12	ND (0.07)
Event 3	20	ND (0.07)
Event 4	17	ND (0.07)
Event 5	14	ND (0.07)
Event 6	9.5	ND (0.065)
Event 7	28	ND (0.32)
Event 8	40	0.2

cis-1,2-DCE	Soil Gas ug/m ³	Indoor Air ug/m ³
Event 1	ND (85)	ND (0.065)
Event 2	240	ND (0.065)
Event 3	88	0.14
Event 4	110	ND (0.07)
Event 5	ND (55)	0.21
Event 6 (with air filtration)	ND (160)	0.41
Event 6 (without air filtration)	NM	0.33
Event 7 (with air filtration)	ND (8,000)	ND (0.67)
Event 7 (without air filtration)	NM	ND (0.14)
Event 8 (with air filtration)	ND (150)	0.26
Event 8 (without air filtration)	NM	ND (0.14)

Legend

- ⊗ 941-## Sub-slab/Indoor Air Location
- Exceeds RIASL₁₂ Only
- Exceeds TSRIASL₁₂
- Exceeds Dow OEL

Media	COC	RIASL ₁₂	TSRIASL ₁₂	OEL
Soil Gas	cis-1,2-Dichloroethene	820	2,500	--
Indoor Air	cis-1,2-Dichloroethene	24	72	794,000

Notes:

All units ug/m³

Initial Sampling Event (1) = May 2017

Seasonal Confirmation Sampling Event 2 = September 2017

Seasonal Confirmation Sampling Event 3 = February 2018

Seasonal Confirmation Sampling Event 4 = August 2018

Seasonal Confirmation Sampling Event 5 = November 2018

Seasonal Confirmation Sampling Event 6 = February 2019

Seasonal Confirmation Sampling Event 7 = April 2019

Seasonal Confirmation Sampling Event 8 = August 2019

Outdoor air location placed near intake located at NE corner of building.

cis-1,2-DCE	Outdoor Air Sample Results ug/m ³
Event 1	ND (0.065)
Event 2	ND (0.07)
Event 3	ND (0.065)
Event 4	ND (0.065)
Event 5	ND (0.06)
Event 6	ND (0.07)
Event 7	ND (0.13)
Event 8	ND (0.14)

cis-1,2-DCE	Soil Gas ug/m ³	Indoor Air ug/m ³
Event 1	ND (1.75)	ND (0.06)
Event 2	14	0.42
Event 3	ND (2.1)	ND (0.065)
Event 4	ND (3.7)	ND (0.065)
Event 5	6.2	ND (0.07)
Event 6	ND (1.55)	ND (0.07)
Event 7	7.9	ND (0.13)
Event 8	12	ND (0.14)

Sub-slab Soil Gas and Indoor Air Results for cis-1,2-Dichloroethene Zone 2 Phase 1 Sampling Events 1 - 8 Building 941



Figure 941-7

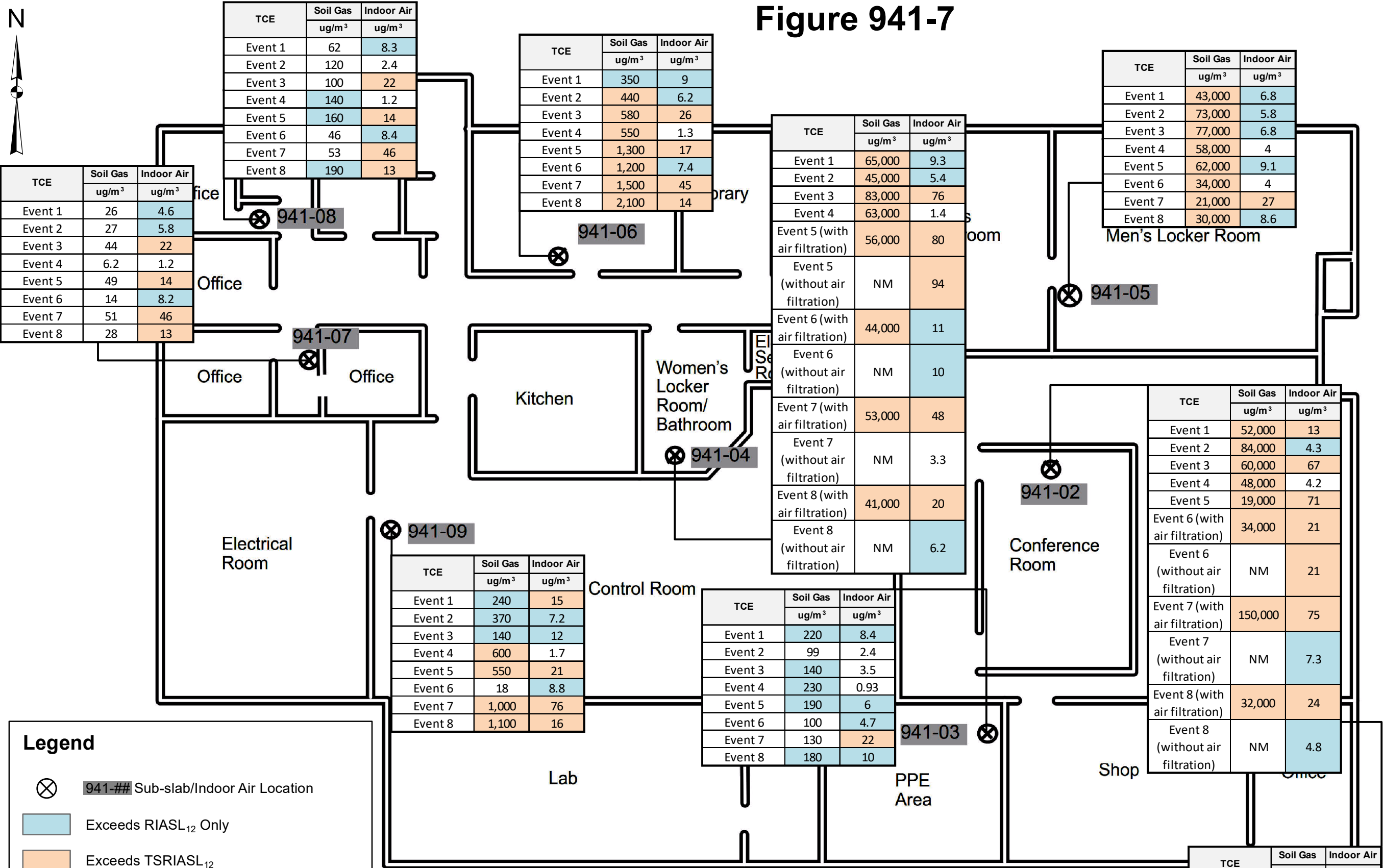

TCE	Soil Gas ug/m ³	Indoor Air ug/m ³
Event 1	26	4.6
Event 2	27	5.8
Event 3	44	22
Event 4	6.2	1.2
Event 5	49	14
Event 6	14	8.2
Event 7	51	46
Event 8	28	13

TCE	Soil Gas ug/m ³	Indoor Air ug/m ³
Event 1	62	8.3
Event 2	120	2.4
Event 3	100	22
Event 4	140	1.2
Event 5	160	14
Event 6	46	8.4
Event 7	53	46
Event 8	190	13

TCE	Soil Gas ug/m ³	Indoor Air ug/m ³
Event 1	350	9
Event 2	440	6.2
Event 3	580	26
Event 4	550	1.3
Event 5	1,300	17
Event 6	1,200	7.4
Event 7	1,500	45
Event 8	2,100	14

TCE	Soil Gas ug/m ³	Indoor Air ug/m ³
Event 1	65,000	9.3
Event 2	45,000	5.4
Event 3	83,000	76
Event 4	63,000	1.4
Event 5 (with air filtration)	56,000	80
Event 5 (without air filtration)	NM	94
Event 6 (with air filtration)	44,000	11
Event 6 (without air filtration)	NM	10
Event 7 (with air filtration)	53,000	48
Event 7 (without air filtration)	NM	3.3
Event 8 (with air filtration)	41,000	20
Event 8 (without air filtration)	NM	6.2

TCE	Soil Gas ug/m ³	Indoor Air ug/m ³
Event 1	43,000	6.8
Event 2	73,000	5.8
Event 3	77,000	6.8
Event 4	58,000	4
Event 5	62,000	9.1
Event 6	34,000	4
Event 7	21,000	27
Event 8	30,000	8.6

TCE	Soil Gas ug/m ³	Indoor Air ug/m ³
Event 1	240	15
Event 2	370	7.2
Event 3	140	12
Event 4	600	1.7
Event 5	550	21
Event 6	18	8.8
Event 7	1,000	76
Event 8	1,100	16

TCE	Soil Gas ug/m ³	Indoor Air ug/m ³
Event 1	220	8.4
Event 2	99	2.4
Event 3	140	3.5
Event 4	230	0.93
Event 5	190	6
Event 6	100	4.7
Event 7	130	22
Event 8	180	10

TCE	Soil Gas ug/m ³	Indoor Air ug/m ³
Event 1	52,000	13
Event 2	84,000	4.3
Event 3	60,000	67
Event 4	48,000	4.2
Event 5	19,000	71
Event 6 (with air filtration)	34,000	21
Event 6 (without air filtration)	NM	21
Event 7 (with air filtration)	150,000	75
Event 7 (without air filtration)	NM	7.3
Event 8 (with air filtration)	32,000	24
Event 8 (without air filtration)	NM	4.8

TCE	Soil Gas ug/m ³	Indoor Air ug/m ³
Event 1	25	1
Event 2	310	2.5
Event 3	200	0.22
Event 4	300	0.92
Event 5	220	1.8
Event 6	59	1.4
Event 7	150	2.3
Event 8	270	0.57

Legend

- ⊗ 941-### Sub-slab/Indoor Air Location
- Blue box: Exceeds RIASL₁₂ Only
- Orange box: Exceeds TSRIASL₁₂
- Yellow box: Exceeds Dow OEL

Media	COC	RIASL ₁₂	TSRIASL ₁₂	OEL
Soil Gas	TCE	130	400	--
Indoor Air	TCE	4	12	26,850

Notes:

All units ug/m³

Initial Sampling Event (1) = May 2017

Seasonal Confirmation Sampling Event 2 = September 2017

Seasonal Confirmation Sampling Event 3 = February 2018

Seasonal Confirmation Sampling Event 4 = August 2018

Seasonal Confirmation Sampling Event 5 = November 2018

Seasonal Confirmation Sampling Event 6 = February 2019

Seasonal Confirmation Sampling Event 7 = April 2019

Seasonal Confirmation Sampling Event 8 = August 2019

Outdoor air location placed near intake located at NE corner of building.

TCE	Outdoor Air Sample ug/m ³
Event 1	ND (0.44)
Event 2	0.35
Event 3	0.43
Event 4	0.3
Event 5	0.26
Event 6	0.2
Event 7	0.87
Event 8	0.32

Sub-slab Soil Gas and Indoor Air Results for Trichloroethene Zone 2 Phase 1 Sampling Events 1 - 8 Building 941

5.3.3 VI Seasonal Confirmation Sampling Results Evaluation for Building 1028

INTRODUCTION

Building 1028 is a Category 1 building in Zone 2 Phase 1. It is a medium-sized single-story office building with a laboratory. It is known as the Sulfonamide Control Room and is located within the central portion of the facility designated as Zone 2 (Figure 5.3.3-1). The 2017 CAIP concluded that the VI pathway at Building 1028 was an insignificant exposure pathway based on current use so it was placed into VI Path Forward Building Group 1 and no further VI evaluation was warranted; however, the 2018 Rescreen Report (August 2018) and 2018 CAIP concluded that although the VI pathway at Building 1028 is an insignificant exposure pathway based on current use, due to a single exceedance of chloroform in sub-slab soil gas, Building 1028 moved into VI Path Forward Building Group 2. Group 2 is a designation for buildings that have sub-slab soil gas AOI(s), but all indoor air results are less than screening levels. Any building placed in Group 2 is scheduled for seasonal confirmation sampling.

The results of the initial sampling event (E1) were evaluated in the 2018 CAIP. The remaining three seasonal events have been completed and the results of all four of these sampling events are included and evaluated herein. No indoor air analytes were detected above screening levels. Chloroform was the only analyte in sub-slab soil gas with exceedances of the draft project-specific RIASL₁₂. There were no sub-slab soil gas results above the TSRIASL₁₂ at Building 1028.

Building 1028	
Initial Sampling Event	Completed
E1	April 2017 (Spring)
Seasonal Confirmation Sampling Event	Completed
E2	October 2018 (Fall)
E3	January 2019 (Winter)
E4	August 2019 (Summer)

Based on the evaluation of the four seasonal confirmation sampling events, the VI pathway continues to be insignificant. Sufficient information exists to make a human exposure under control EI determination.

SUB-SLAB SOIL GAS RESULTS EVALUATION

Four sub-slab soil gas samples and four indoor air samples were collected (along with one outdoor air sample). The sampling locations are shown on Figure 5.3.3-2. Summary statistics and screening comparison results are presented for sub-slab soil gas on Table 5.3.3-A and indoor and outdoor air on Table 5.3.3-B. The analytical reports are presented in Appendix A. Field sampling logs are provided in Appendix B. Table 1028-1 presents the sub-slab soil gas results that exceed the draft project-specific RIASL₁₂.

Table 1028-1. Summary of Sub-Slab Soil Gas Detects for Building 1028

Analyte (Sample Event)	Detection Frequency	Measured Range of Detects ($\mu\text{g}/\text{m}^3$)	% Detections > Screening Level	Screening Level* ($\mu\text{g}/\text{m}^3$)
Chloroform (1)	100%	7.2 - 260	25%	170
Chloroform (2)	75%	47 - 340	25%	170
Chloroform (3)	100%	6.6 - 360	25%	170
Chloroform (4)	100%	8.5 - 400	25%	170

*Screening level provided is the draft project-specific RIASL₁₂.

Table 1028-2 summarizes the indoor air results relative to the sub-slab soil gas exceedances, since VI only potentially occurs if the analyte is present in both sub-slab soil gas and indoor air. Therefore, the

table below provides the analytes detected above applicable screening levels in sub-slab soil gas as well as the corresponding indoor air sample results. The outdoor air sample results are also provided to determine if the analytes were present in indoor air due to migration from outdoor air.

Table 1028-2. Vapor Intrusion Evaluation for Building 1028

Analyte	Indoor Air Detection Frequency	Indoor Air Measured Range ($\mu\text{g}/\text{m}^3$)	Indoor Air Screening Level* ($\mu\text{g}/\text{m}^3$)	Outdoor Air Result ($\mu\text{g}/\text{m}^3$)
Chloroform (1)	100%	0.24 - 0.48	5.2	0.23
Chloroform (2)	100%	0.21 - 0.5	5.2	0.18
Chloroform (3)	100%	0.32 - 0.56	5.2	0.24
Chloroform (4)	100%	0.41 - 0.77	5.2	ND

*Screening level provided is the draft project-specific RIASL12.

All indoor air results for chloroform are below the screening level.

VAPOR INTRUSION CONCEPTUAL SITE MODEL

VI is an exposure pathway that results from the migration of volatilized chemicals from the subsurface to indoor air in overlying occupied buildings. A source, migration route and a human receptor must be present for the VI pathway to be complete. The focus of this building specific investigation is to evaluate the potential VI exposure pathway for Dow employees and contractors at Building 1028. The CSM is illustrated in Figure 5.3.3-3.

Building 1028 is a medium-sized single-story office building with a laboratory. It is approximately 5,250 ft² in size and is known as the Sulfonamide Control Room. The building has central AC with two units and the air intake is located at the southeast corner of the building. This building does not have any bay doors. The land surrounding the building is covered in asphalt.

Approximately 20 people occupy Building 1028. The building is occupied from 8am to 5pm Monday through Friday by office personnel and by operations personnel for two 12-hour shifts per day Monday through Friday. The typical parameters for non-residential exposures are assumed to apply to the various security personnel stationed during rotating work shifts at this building (i.e., 40 hours/week, 50 weeks/year exposure).

A building survey was completed before the initial sampling event. Drains and other openings were screened with a PID and no soil gas entry points were identified. A chemical inventory was completed during the building survey that identified cleaners, penetrating oil lubricant, and spray enamel and spray paint.

EVALUATION OF SEASONAL CONFIRMATION SAMPLING EVENTS

Four seasonal sampling events have been completed at Building 1028. The sampling events encompass more than one year of time and include sampling during each season of the year. The results from the four seasonal confirmation sampling events were evaluated with respect to spatial variability, temporal variability, and seasonal trend analysis. The analysis was limited, however by the small number of VOCS and the lack of relatively high concentrations among the detected values.

Building specific attenuation factors were calculated and compared between events to evaluate temporal variability and determine the best estimate of a building-specific attenuation factor. This evaluation serves to confirm that the existing study design is appropriate, and also provides insight for the determination of the path forward for this building.

This evaluation focused on any analytes detected in the sub-slab soil gas samples that met the criterion for inclusion in one or more of the following categories:

- a) Analytes detected in sub-slab soil gas at concentrations that exceeded draft project-specific screening levels;
- b) Analytes detected in sub-slab soil gas at concentrations of 1,000 $\mu\text{g}/\text{m}^3$ or greater in one or more samples. Data for analytes detected above 1,000 $\mu\text{g}/\text{m}^3$ should provide the clearest signal and be the simplest to interpret when assessing data trends. The same data trends observed for these analytes are expected to apply to other similar analytes present at lower concentrations; and
- c) PCE and TCE. These two analytes are of particular interest for many VI evaluations at industrial sites.

For this building, the only analyte detected in the sub-slab soil gas at concentrations above the draft project-specific screening level is chloroform. There are no analytes detected at concentrations \geq 1,000 $\mu\text{g}/\text{m}^3$ in soil gas. PCE is included in this evaluation; however, TCE is not included in this evaluation due to the low detection frequency and very low detected concentrations (TCE detected results range from 4.3 - 7.1 $\mu\text{g}/\text{m}^3$). Sample results for chloroform and PCE are provided in the following data tables.

Summary of Results for Chloroform

Sample Type	Sample ID	Measured Concentration ($\mu\text{g}/\text{m}^3$)			
		Apr. 2017	Oct. 2018	Jan. 2019	Aug. 2019
		E1	E2	E3	E4
Outdoor Air	1028-OA-01	0.23	0.18	0.24	<0.18
Indoor Air	1028-IA-01	0.24	0.22	0.35	0.48
	1028-IA-02	0.34	0.30	0.56	0.68
	1028-IA-03	0.24	0.21	0.32	0.41
	1028-IA-04	0.48	0.5	0.43	0.77
Sub-Slab Soil Gas	1028-SS-01	40	47	32	37
	1028-SS-02	47	50	16	24
	1028-SS-03	7.2	<4	6.6	8.5
	1028-SS-04	260	340	360	400

Screening levels for indoor air are 5.2 $\mu\text{g}/\text{m}^3$ (RIASL₁₂) and 52 $\mu\text{g}/\text{m}^3$ (TSRIASL₁₂)
Screening levels for soil-gas are 170 $\mu\text{g}/\text{m}^3$ (RIASL₁₂) and 1700 $\mu\text{g}/\text{m}^3$ (TSRIASL₁₂)

	RIASL12 Exceedance
	TSRIASL12 Exceedance

Summary of Results for Tetrachloroethene (PCE)

Sample Type	Sample ID	Measured Concentration ($\mu\text{g}/\text{m}^3$)			
		Apr. 2017	Oct. 2018	Jan. 2019	Aug. 2019
		E1	E2	E3	E4
Outdoor Air	1028-OA-01	<0.22	<0.23	<0.17	1.2
Indoor Air	1028-IA-01	<0.22	<0.24	<0.22	1.1
	1028-IA-02	<0.22	<0.25	<0.23	1.2
	1028-IA-03	<0.23	<0.22	<0.20	1.3
	1028-IA-04	<0.22	<0.26	<0.21	1.2
Sub-Slab Soil Gas	1028-SS-01	760	770	670	690
	1028-SS-02	13	20	7.4	18
	1028-SS-03	270	140	260	300
	1028-SS-04	92	140	190	180

Screening levels for indoor air are $82 \mu\text{g}/\text{m}^3$ (RIASL₁₂ and TSRIASL₁₂)

Screening levels for soil-gas are $2700 \mu\text{g}/\text{m}^3$ (RIASL₁₂ and TSRIASL₁₂)

	RIASL12 Exceedance
	TSRIASL12 Exceedance

EVALUATION OF VI DATA TRENDS

Data trends for Building 1028 are discussed below for both sub-slab soil gas and indoor air. When data exhibit a narrow range of variability, it is typical practice to express the range as a percentage. When data exhibit a large range of variability, however, it is more useful to express the range in orders of magnitude (i.e., factors of 10). This can be expressed mathematically as the log of the ratio of maximum/minimum values. If the values differ by a factor of 10, the log of the ratio is 1, if the values differ by a factor of 100, the log of the ratio is 2, and so on.

The variability across all locations over all sampling events is the total variability. This encompasses different types of variability, including spatial variability (i.e., how do the results vary from location to location), temporal variability (i.e., how do the results at a given location vary over time), and measurement variability. Measurement variability can be determined by evaluating results of duplicate or collocated samples and includes both sampling variability and analytical variability.

Sub-Slab Soil Gas Data Trends

Spatial Variability of Sub-Slab Soil Gas – As shown in the tables above, PCE was detected in each sub-slab soil gas sample location for all four seasonal confirmation sampling events and the concentrations varied from 7.4 to $770 \mu\text{g}/\text{m}^3$. Chloroform was detected in all but one sample location during one of the seasonal sampling events and the detected sub-slab soil gas concentrations varied from 6.6 - $400 \mu\text{g}/\text{m}^3$. The soil gas concentrations of PCE across all four sampling events exhibit slightly two orders of magnitude of spatial variability (log of max./min. = 2.0). The maximum variability for any one sampling event was 7.4 to $670 \mu\text{g}/\text{m}^3$ (log of max./min. = 1.96). The soil gas concentrations of chloroform across all four sampling events exhibit slightly less than two orders of magnitude of spatial variability (log of max./min. = 1.8). The maximum variability for any one sampling event was <4 to $340 \mu\text{g}/\text{m}^3$ (log of max./min. = 1.9). Based on this data, the spatial variability in sub-slab soil gas is about as expected given the size of the building and the number of sampling locations.

Temporal Variability of Soil Gas – The soil gas concentrations from one event to another vary by up to a factor of three. For example, sub-slab soil gas concentrations of chloroform vary from 16 to $50 \mu\text{g}/\text{m}^3$ at location 1028-SS-02 and from 260 to $400 \mu\text{g}/\text{m}^3$ at location 1028-SS-04. For PCE, sub-slab soil gas concentrations vary from 670 to $770 \mu\text{g}/\text{m}^3$ at location 1028-SS-01 (RPD = 14%). Based on this evaluation, there is a relatively modest amount of temporal variability in sub-slab soil gas which is in-line with expectations. Overall, the amount of temporal variability is less than the amount of spatial variability.

Seasonal Confirmation Sampling Trend Analysis – No formal statistical tests were performed, but the data does not exhibit any definite upward or downward trend over the course of the four seasonal sampling events; however, for Building 1028 the event with the highest sample results occurred in the fall. This is illustrated in the graphs below. Plots for chloroform and PCE are shown below for sample locations 1028-SS-01 and 1028-SS-04. Note that the y-axis is a log scale.

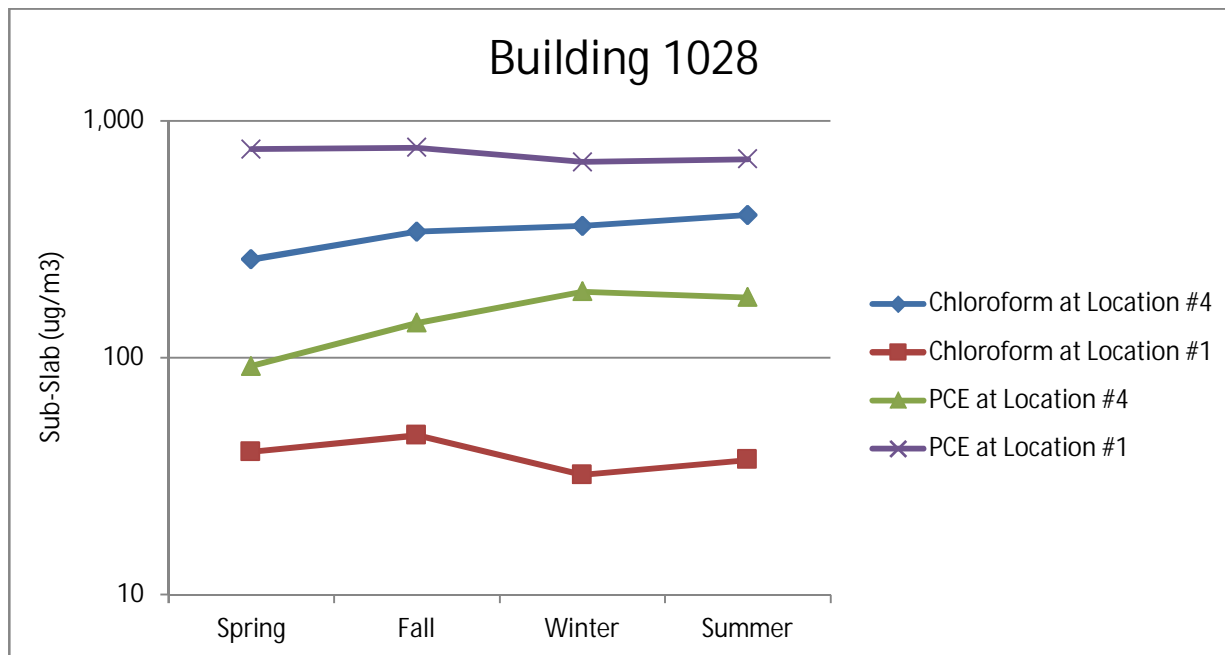

The data set was examined to see what the potential consequences would have been had only a single sampling event been performed. For PCE at 1028-SS-01, the highest sub-slab concentration was collected during the fall (E2) and the lowest concentration occurred during the winter (E3). For chloroform at 1028-SS-04, the highest sub-slab concentration was collected during the summer (E4) and the lowest concentration occurred during the spring (E1). Overall, the minimum and maximum values appear to be randomly distributed among the various sampling events.

For chloroform at location 1028-SS-04, the lowest value (260 $\mu\text{g}/\text{m}^3$) was measured during E1 and the highest concentration (400 $\mu\text{g}/\text{m}^3$) was measured during E4. If only E1 had been performed, a negative bias of 54% would have been introduced (i.e., the E4 result was 54% higher than the E1 result). Therefore, implementing four seasonal confirmation sampling events provided a larger data set and increased the confidence in the findings including demonstrating the maximum reported results were reasonably consistent.

Indoor Air Data Trends

Spatial Variability of Indoor Air – Since PCE was only detected in indoor air during E4, an evaluation of spatial variability could only be performed for that event. For PCE during E4, indoor air concentrations vary from 1.1 to 1.3 $\mu\text{g}/\text{m}^3$ yielding an RPD of 17%. The PCE data suggests the air within the building is well-mixed and influenced by outdoor air, since the concentrations of indoor and outdoor air are roughly equivalent. For chloroform, the highest spatial variability occurred during E4 where indoor air concentrations of chloroform vary from 0.41 to 0.77 $\mu\text{g}/\text{m}^3$ yielding an RPD of 61%. The RPDs for chloroform during the other sampling events are similar (67%, 82%, and 55%). The data suggest that there are indoor sources of chloroform (e.g., tap water), which leads to more spatial variability for this compound versus PCE.

Temporal Variability of Indoor Air – The indoor air exhibits only about a factor of two temporal variability. For example, indoor air concentrations of chloroform at location 1028-IA-01 varied from 0.22 to 0.48 $\mu\text{g}/\text{m}^3$ (RPD = 74%). Chloroform at location 1028-IA-04 varied from 0.43 to 0.77 $\mu\text{g}/\text{m}^3$ (RPD = 57%). Therefore, temporal variability across the four seasons sampled is considered to be relatively small.

Additional Analyses

Comparison of Sub-Slab Soil Gas and Indoor Air Data Sets – As expected, the sub-slab soil gas data exhibit greater spatial variability than the indoor air data set. Also as expected, the indoor air data exhibit greater temporal variability than the sub-slab soil gas data set (though neither data set has significant temporal variability). For most analytes, however, the comparisons are limited by the large percentage of ND values in both the sub-slab and the indoor air data sets.

Seasonal Effects – The sub-slab soil gas data exhibit relatively little variability from event to event. Maximum soil-gas values for chloroform were detected during E2 (i.e., fall). The indoor air data set is predominantly ND values, but the highest chloroform values and the only PCE detections occurred during E4 (i.e., summer). The data do not support the hypothesis that wintertime should have the highest indoor air impacts.

Comparison of Attenuation Factors by Event – Attenuation factors were calculated for PCE based on maximum values in sub-slab soil gas since it had a 100% detection frequency for each of the seasonal confirmation sampling events. For indoor air, the maximum detected result or the maximum ND RL was used for each sampling event. The calculated event-specific attenuation factors are shown in the Table 1028-3 below.

Table 1028-3. Comparison of Building-Specific Attenuation Factors for PCE by Event

	E1 (Spring)	E2 (Fall)	E3 (Winter)	E4 (Summer)
Maximum Values				
PCE in Sub-Slab Soil Gas ($\mu\text{g}/\text{m}^3$)	760	770	670	690
PCE in Indoor Air ($\mu\text{g}/\text{m}^3$)	<0.23	<0.26	<0.23	1.3
Attenuation Factor	<3.0E-04	<3.4E-04	<3.4E-04	1.9E-03

The most conservative of a building-specific attenuation factor for Building 1028 is 1.9E-03 based on PCE during E4. This value is also the only attenuation factor derived from a sampling event with a detected result in indoor air; however, it's important to note that the indoor air results for PCE during E4 appear to be heavily influenced by outdoor air results and not related to VI. If the contribution from outdoor air were subtracted out, the calculated attenuation factor would be an order of magnitude lower (i.e., 1.4E-04), which would make it consistent with the other rounds of testing.

The best estimate for a worst-case, building-specific attenuation factor (due to use of a ND RL as the maximum result) would be 3.4E-04; however, for the sake of conservatism, 1.9E-03 will be selected for Building 1028.

Temporal Variability in Attenuation Factor – As shown in Table 1028-3, there was at most about one order of magnitude temporal variability in the calculated attenuation factors observed for PCE.

To be as conservative as possible, the maximum values were used in calculating the attenuation factor for each event. All maximum sub-slab soil gas values for PCE are from sample location 1028-xx-01; however, the indoor air values at that location are no higher than at any of the other locations. The low spatial variability in indoor air results means that similar attenuation factors would be obtained whichever indoor air value was used in the calculations.

NON-DETECT EVALUATION

EDB is the only ND analyte in sub-slab soil gas with a RL that exceeds the screening level. During E1, 1028-SS-01 had a single ND RL ($8.1 \mu\text{g}/\text{m}^3$) greater than the screening level ($6.6 \mu\text{g}/\text{m}^3$); however, all sub-slab soil gas ND RLs at that same location for the following three sampling events were below the screening level. During E4, 1028-SS-04 had a ND RL ($6.7 \mu\text{g}/\text{m}^3$) greater than the screening level ($6.6 \mu\text{g}/\text{m}^3$); however, all sub-slab soil gas results at that same location for the previous three sampling events were ND with RLs below the screening level.

WEIGHT-OF-EVIDENCE SUMMARY

Building 1028 was confirmed as a VI Path Forward Group 2 building due to its potential for VI based on sub-slab soil gas exceedances of the draft project-specific RIASL₁₂ for chloroform. However, after further investigation and evaluation, the following evidence supports the conclusion that VI is insignificant at Building 1028:

- No exceedances of draft project-specific screening levels in indoor air.
- No exceedances of TSRIASL₁₂ in sub-slab soil gas.
- The sub-slab soil gas data do not show any strong time dependence nor do the data show any strong seasonal effects.
- The data do not support the hypothesis that wintertime should have the highest indoor air impacts. The highest sub-slab soil gas concentrations generally were measured in the fall. Similarly, the highest indoor air concentrations were measured in the summer.
- The indoor air data show relatively little spatial variability, despite the somewhat greater spatial variability in the sub-slab soil gas values. This evaluation confirms that the sub-slab soil gas and indoor air concentrations were reasonably consistent from season to season.
- As shown in the table below, the building-specific attenuation factor yields estimated indoor air concentration for chloroform nearly identical to the measured result at 1028-IA-04 and both concentrations are below the screening level. Any conservatism in the attenuation factor is countered by the contributions from any indoor sources.

Parameters	Chloroform
Building-specific AF	1.9E-03
Maximum detected concentration in SSSG	400
Estimated Indoor Air Concentration	0.76
Detected Indoor Air Concentration - 1028-IA-04	0.77
Indoor Air RIASL ₁₂	5.2
Indoor Air TSRIASL ₁₂	52

Based on the CSM for Building 1028, VI is an insignificant exposure pathway for current building utilization.

PATH FORWARD

Based on the evaluation of the four seasonal confirmation sampling events, the VI pathway continues to be insignificant for Building 1028 and the sub-slab soil gas results have demonstrated relatively stable concentrations and no evidence of increasing over time. Sufficient information exists to make a human exposure under control EI determination. However, while currently there is no evidence of potential VI, for future use, LTM is warranted and the building-specific Interim Monitoring Plan is discussed below.

Building-specific Interim Monitoring Plan

Dow will implement an Interim Monitoring Plan at Building 1028 until a revised program or more permanent Corrective Action Plan is developed for the site.

Indoor air will be monitored at location 1028-IA-04. This location was selected for continued monitoring since it demonstrated the highest sub-slab soil gas results. Monitoring will be performed for chloroform. An outdoor air sample will also be collected at the time of each monitoring event. Interim monitoring will be performed semi-annually for a minimum of two years and monitoring results will undergo trend analysis. The initial interim monitoring event will occur in Summer 2020. If results continue to be consistent and below screening levels, monitoring will be conducted on an annual basis. If indoor air results are observed to be increasing, further evaluation will be performed, which may include collection of a sub-slab soil gas sample(s) and an increase in monitoring frequency. Results from each monitoring event will be reported in the annual CAIP. In the event an indoor air result(s) exceeds screening levels, MDEQ will be provided a brief email notification. A collocated indoor air and sub-slab soil gas sample will be collected from that location within 45 days. If both sub-slab soil gas and indoor air results indicate that VI continues to be insignificant, monitoring will continue at an appropriate frequency. If both sub-slab soil gas and indoor air results indicate that VI is significant and confirm Group 4 conditions, the building will be moved to Group 4 for follow-up actions.

Dow may propose changes to the frequency or other aspects of this Interim Monitoring Plan in the future based on an evaluation of the data, changes in building use or implementation of other corrective actions to address the potential VI pathway.

5.3.4 VI Seasonal Confirmation Sampling Results Evaluation for Building 1233

INTRODUCTION

Building 1233 is a Category 1 building located in the central portion of the facility designated as Zone 2 (Figure 5.3.4-1). It is known as the Garlon Plant Granular Building and is a single-story building that includes process area, a laboratory, a shop, and office space.

The initial evaluation in the 2017 CAIP placed Building 1233 in VI Path Forward Building Group 2 due to sub-slab soil gas exceedances and the building was placed into seasonal confirmation sampling. The results of E1 through E3 were re-evaluated in the 2018 Rescreen Report and in Section 5.2.7 in the 2018 CAIP. Building 1233 remained in Group 2 due to exceedances of seven sub-slab soil gas analytes and no indoor air exceedances. Since then, the final seasonal confirmation sampling event (E4) was completed and Building 1233 moved into interim monitoring.

Building 1233	
Initial Sampling Event	Completed
E1	May 2017 (Spring)
Seasonal Sampling Event	Completed
E2	February 2018 (Winter)
E3	August 2018 (Summer)
E4	November 2018 (Fall)

Based on the evaluation of the four seasonal confirmation sampling events, the VI pathway continues to be insignificant. Sufficient information exists to make a human exposure under control EI determination.

SUB-SLAB SOIL GAS EVALUATION

Sub-slab soil gas samples were collected from four locations from within the building. Indoor air samples were collected at four locations corresponding to the soil gas sample locations, along with an outdoor air

sample from the main air intake. The sampling locations are shown on Figure 5.3.4-2. Summary statistics and screening comparison results are presented for sub-slab soil gas on Table 5.3.4-A and indoor and outdoor air on Table 5.3.4-B. The analytical data are presented in Appendix A. Field sampling logs are provided in Appendix B. Table 1233-1 presents the sub-slab soil gas results that exceed the draft project-specific screening levels. TCE and PCE also had exceedances greater than the sub-slab soil gas TSRIASL₁₂.

Table 1233-1. Summary of Sub-Slab Soil Gas Exceedances for Building 1233

Analyte (Sampling Event)	Detection Frequency	Measured Range of Detects ($\mu\text{g}/\text{m}^3$)	% Detections > Screening Level	Screening Level* ($\mu\text{g}/\text{m}^3$)
1,1,2-Trichloroethane (1)	50%	300 - 470	50%	20
1,1,2-Trichloroethane (2)	50%	250 - 420	50%	20
1,1,2-Trichloroethane (3)	50%	160 - 220	50%	20
1,1,2-Trichloroethane (4)	0%	ND	0%	20
1,2-Dichloroethane (1)	100%	6.6 - 1,000	50%	150
1,2-Dichloroethane (2)	75%	8.2 - 1,200	50%	150
1,2-Dichloroethane (3)	50%	250 - 340	50%	150
1,2-Dichloroethane (4)	75%	5.9 - 960	50%	150
1,2-Dichloropropane (1)	75%	32 - 2,600	50%	410
1,2-Dichloropropane (2)	75%	30 - 2,700	50%	410
1,2-Dichloropropane (3)	75%	17 - 810	50%	410
1,2-Dichloropropane (4)	75%	32 - 2,500	50%	410
Chloroform (1)	100%	78 - 480	50%	170
Chloroform (2)	100%	77 -- 420	50%	170
Chloroform (3)	100%	67 - 310	25%	170
Chloroform (4)	100%	53 - 450	50%	170
Hexachlorobutadiene (1)	75%	250 - 5,200	75%	180
Hexachlorobutadiene (2)	100%	46 - 4,300	75%	180
Hexachlorobutadiene (3)	100%	68 - 2,200	75%	180
Hexachlorobutadiene (4)	100%	160 - 4,400	75%	180
Tetrachloroethene (1)	100%	580 - 7,100	50%	2,700
Tetrachloroethene (2)	100%	490 - 6,200	50%	2,700
Tetrachloroethene (3)	100%	600 - 3,700	25%	2,700
Tetrachloroethene (4)	100%	600 - 7,200	50%	2,700
Trichloroethene (1)	100%	8.2 - 16,000	50%	130
Trichloroethene (2)	75%	51 - 14,000	50%	130
Trichloroethene (3)	75%	39 - 5,800	50%	130
Trichloroethene (4)	75%	74 - 18,000	50%	130

*Screening level provided is the draft project-specific RIASL₁₂.

Table 1233-2 summarizes the indoor air results relative to the sub-slab soil gas exceedances, since VI only potentially occurs if the analyte is present in both sub-slab soil gas and indoor air. Therefore, the table below provides the analytes detected above applicable screening levels in sub-slab soil gas as well as the corresponding indoor air sample results. The outdoor air sample results are also provided to determine if the analytes were present in indoor air due to migration from outdoor air.

Table 1233-2. Vapor Intrusion Evaluation for Building 1233

Analyte	Indoor Air Detection Frequency	Indoor Air Measured Range ($\mu\text{g}/\text{m}^3$)	Indoor Air Screening Level* ($\mu\text{g}/\text{m}^3$)	Outdoor Air Result ($\mu\text{g}/\text{m}^3$)
1,1,2-Trichloroethane (1)	0%	ND	0.62	ND
1,1,2-Trichloroethane (2)	25%	0.24	0.62	ND
1,1,2-Trichloroethane (3)	0%	ND	0.62	ND
1,1,2-Trichloroethane (4)	0%	ND	0.62	ND

Table 1233-2. Vapor Intrusion Evaluation for Building 1233 (Continued)

Analyte	Indoor Air Detection Frequency	Indoor Air Measured Range ($\mu\text{g}/\text{m}^3$)	Indoor Air Screening Level* ($\mu\text{g}/\text{m}^3$)	Outdoor Air Result ($\mu\text{g}/\text{m}^3$)
1,2-Dichloroethane (1)	0%	ND	4.6	ND
1,2-Dichloroethane (2)	100%	0.19 - 0.25	4.6	0.12
1,2-Dichloroethane (3)	100%	0.47 - 0.69	4.6	0.14
1,2-Dichloroethane (4)	100%	0.65 - 0.86	4.6	0.30
1,2-Dichloropropane (1)	0%	ND	12.2	ND
1,2-Dichloropropane (2)	0%	ND	12.2	ND
1,2-Dichloropropane (3)	0%	ND	12.2	ND
1,2-Dichloropropane (4)	0%	ND	12.2	ND
Chloroform (1)	100%	0.67 - 0.77	5.2	0.34
Chloroform (2)	100%	1.2 - 1.7	5.2	0.37
Chloroform (3)	100%	1.0 - 1.5	5.2	0.97
Chloroform (4)	100%	0.39 - 1.3	5.2	ND
Hexachlorobutadiene (1)	0%	ND	5.4	ND
Hexachlorobutadiene (2)	0%	ND	5.4	ND
Hexachlorobutadiene (3)	0%	ND	5.4	ND
Hexachlorobutadiene (4)	0%	ND	5.4	ND
Tetrachloroethene (1)	50%	0.22 - 0.24	82	ND
Tetrachloroethene (2)	100%	1.0 - 1.6	82	0.73
Tetrachloroethene (3)	100%	3.1 - 3.3	82	2.4
Tetrachloroethene (4)	100%	1.0 - 2.9	82	ND
Trichloroethene (1)	25%	0.22	4	ND
Trichloroethene (2)	75%	0.27 - 1.5	4	ND
Trichloroethene (3)	100%	0.57 - 1.2	4	ND
Trichloroethene (4)	100%	0.28 - 1.4	4	ND

*Screening level provided is the draft project-specific RIASL₁₂.

All indoor air results for Building 1233 are less than screening levels.

VAPOR INTRUSION CONCEPTUAL SITE MODEL

VI is an exposure pathway that results from the migration of volatilized chemicals from the subsurface to indoor air in overlying occupied buildings. A source, migration route and a human receptor must be present for the VI pathway to be complete. The focus of this building specific investigation is to evaluate the potential VI exposure pathway for employees and contractors at Building 1233. The CSM is illustrated in Figure 5.3.4-3.

Building 1233 is a single-story building that includes process area, a laboratory, a shop, and office space. Approximately 20 people occupy Building 1233. The building is occupied from 8am to 5pm Monday through Friday by office personnel and by operations personnel for four 6-hour shifts per day seven days a week. The typical parameters for non-residential exposures are assumed to apply to the various personnel stationed during rotating work shifts at this building (i.e., 40 hours/week, 50 weeks/year exposure).

The building survey completed before the initial sampling event. Drains and other openings were screened with a PID and no soil gas entry points were identified. A chemical inventory was completed during the building survey and the chemicals found to be stored within the building, each listed in the survey, included cleaners, gas duster, insecticides, and spray paint.

EVALUATION OF SEASONAL CONFIRMATION SAMPLING EVENTS

Four seasonal sampling events have been completed at Building 1233. The sampling events encompass more than one year of time and include sampling during each season of the year. The results from the

four seasonal confirmation sampling events were evaluated with respect to spatial variability, temporal variability, and seasonal trend analysis.

Building specific attenuation factors (α) were calculated and compared between events to evaluate temporal variability and determine the best estimate of a building-specific attenuation factor. This evaluation serves to confirm that the existing study design is appropriate, and also provides insight for the determination of the path forward for this building.

This evaluation focused on any analytes detected in the sub-slab soil gas samples that met the criterion for inclusion in one or more of the following categories:

- Analytes detected in sub-slab soil-gas at concentrations that exceeded draft project-specific screening levels;
- Analytes detected in sub-slab soil-gas at concentrations of $1,000 \mu\text{g}/\text{m}^3$ or greater in one or more samples. Data for analytes detected above $1,000 \mu\text{g}/\text{m}^3$ should provide the clearest signal and be the simplest to interpret when assessing data trends. The same data trends observed for these analytes are expected to apply to other similar analytes present at lower concentrations; and
- PCE and TCE. These two analytes are of particular interest for many VI evaluations at industrial sites.

For this building, the analytes detected in the sub-slab soil gas at concentrations above the draft project-specific screening levels were 1,1,2-TCA, 1,2-DCA, 1,2-DCP, chloroform, HCBd, PCE, and TCE. Sample results for these seven analytes are provided in the following data tables below. Five additional analytes were detected at concentrations $\geq 1,000 \mu\text{g}/\text{m}^3$ in soil gas (1,1,1-TCA, 2,2,4-trimethylpentane, CFC-12, toluene, and total xylenes); however these analytes will be excluded from this evaluation due to the large number of analytes with screening level exceedances.

Summary of Results for 1,1,2-Trichloroethane (1,1,2-TCA)

Sample Type	Sample ID	Measured Concentration ($\mu\text{g}/\text{m}^3$)			
		May. 2017	Feb. 2018	Aug. 2018	Nov. 2018
		E1	E2	E3	E4
Outdoor Air	1233-OA-01	<0.18	<0.17	<0.18	<0.18
Indoor Air	1233-IA-01	<0.18	<0.18	<0.19	<0.17
	1233-IA-02	<0.18	<0.18	<0.19	<0.18
	1233-IA-03	<0.26	<0.18	<0.19	<0.18
	1233-IA-04	<0.18	0.24	<0.19	<0.19
Sub-Slab Soil Gas	1233-SS-01	<8.9	<5.3	<5.4	<6.6
	1233-SS-02	300	250	220	<36
	1233-SS-03	<4.6	<4.3	<5.5	<4.5
	1233-SS-04	470	420	160	<45

Screening levels for indoor air are $0.62 \mu\text{g}/\text{m}^3$ (RIASL₁₂)

Screening levels for soil-gas are $20 \mu\text{g}/\text{m}^3$ (RIASL₁₂)

	RIASL12 Exceedance
	TSRIASL12 Exceedance

Summary of Results for 1,2-Dichloroethane

Sample Type	Sample ID	Measured Concentration ($\mu\text{g}/\text{m}^3$)			
		May. 2017	Feb. 2018	Aug. 2018	Nov. 2018
		E1	E2	E3	E4
Outdoor Air	1233-OA-01	<0.13	0.12	0.14	0.30
Indoor Air	1233-IA-01	<0.13	0.20	0.69	0.42
	1233-IA-02	<0.13	0.22	0.47	0.43
	1233-IA-03	<0.20	0.19	0.52	0.46
	1233-IA-04	<0.14	0.25	0.55	0.44
Sub-Slab Soil Gas	1233-SS-01	6.6	8.2	<4	5.9
	1233-SS-02	390	370	250	360
	1233-SS-03	9.9	<3.2	<4.1	<3.3
	1233-SS-04	1,000	1,200	340	960

Screening levels for indoor air are $4.6 \mu\text{g}/\text{m}^3$ (RIASL₁₂)

Screening levels for soil-gas are $150 \mu\text{g}/\text{m}^3$ (RIASL₁₂)

Summary of Results for 1,2-Dichloropropane

Sample Type	Sample ID	Measured Concentration ($\mu\text{g}/\text{m}^3$)			
		May. 2017	Feb. 2018	Aug. 2018	Nov. 2018
		E1	E2	E3	E4
Outdoor Air	1233-OA-01	<0.77	<0.72	<0.78	<0.78
Indoor Air	1233-IA-01	<0.76	<0.74	<0.81	<0.74
	1233-IA-02	<0.76	<0.76	<0.81	<0.77
	1233-IA-03	<1.1	<0.74	<0.81	<0.78
	1233-IA-04	<0.78	<0.8	<0.79	<0.82
Sub-Slab Soil Gas	1233-SS-01	32	30	17	32
	1233-SS-02	1,200	960	750	1,100
	1233-SS-03	<3.9	<3.6	<4.7	<3.8
	1233-SS-04	2,600	2,700	810	2,500

Screening levels for indoor air are $12.2 \mu\text{g}/\text{m}^3$ (RIASL₁₂)

Screening levels for soil-gas are $410 \mu\text{g}/\text{m}^3$ (RIASL₁₂)

Summary of Results for Chloroform

Sample Type	Sample ID	Measured Concentration ($\mu\text{g}/\text{m}^3$)			
		May. 2017	Feb. 2018	Aug. 2018	Nov. 2018
		E1	E2	E3	E4
Outdoor Air	1233-OA-01	<0.77	<0.72	<0.78	<0.78
Indoor Air	1233-IA-01	<0.76	<0.74	<0.81	<0.74
	1233-IA-02	<0.76	<0.76	<0.81	<0.77
	1233-IA-03	<1.1	<0.74	<0.81	<0.78
	1233-IA-04	<0.78	<0.8	<0.79	<0.82
Sub-Slab Soil Gas	1233-SS-01	32	30	17	32
	1233-SS-02	1,200	960	750	1,100
	1233-SS-03	<3.9	<3.6	<4.7	<3.8
	1233-SS-04	2,600	2,700	810	2,500

Screening levels for indoor air are $5.2 \mu\text{g}/\text{m}^3$ (RIASL₁₂) and $52 \mu\text{g}/\text{m}^3$ (TSRIASL₁₂)
Screening levels for soil-gas are $170 \mu\text{g}/\text{m}^3$ (RIASL₁₂) and $1700 \mu\text{g}/\text{m}^3$ (TSRIASL₁₂)

	RIASL ₁₂ Exceedance
	TSRIASL ₁₂ Exceedance

Summary of Results for Hexachlorobutadiene

Sample Type	Sample ID	Measured Concentration ($\mu\text{g}/\text{m}^3$)			
		May. 2017	Feb. 2018	Aug. 2018	Nov. 2018
		E1	E2	E3	E4
Outdoor Air	1233-OA-01	<8.8	<8.3	<9.1	<9
Indoor Air	1233-IA-01	<8.7	<8.6	<9.3	<8.5
	1233-IA-02	<8.8	<8.7	<9.4	<8.9
	1233-IA-03	<13	<8.6	<9.3	<9.1
	1233-IA-04	<9	<9.2	<9.2	<9.4
Sub-Slab Soil Gas	1233-SS-01	<69	46	68	160
	1233-SS-02	1,800	1,400	1,600	1,700
	1233-SS-03	250	190	270	270
	1233-SS-04	5,200	4,300	2,200	4,400

Screening levels for indoor air are $5.4 \mu\text{g}/\text{m}^3$ (RIASL₁₂)Screening levels for soil-gas are $180 \mu\text{g}/\text{m}^3$ (RIASL₁₂)**Summary of Results for Tetrachloroethene (PCE)**

Sample Type	Sample ID	Measured Concentration ($\mu\text{g}/\text{m}^3$)			
		May. 2017	Feb. 2018	Aug. 2018	Nov. 2018
		E1	E2	E3	E4
Outdoor Air	1233-OA-01	<0.22	0.73	2.4	<0.23
Indoor Air	1233-IA-01	0.22	1	3.1	1
	1233-IA-02	<0.22	1.6	3.3	1.4
	1233-IA-03	<0.33	1.3	3.2	2.9
	1233-IA-04	0.24	1.5	3.1	1.3
Sub-Slab Soil Gas	1233-SS-01	720	620	770	800
	1233-SS-02	4,800	4,200	3,700	4,600
	1233-SS-03	580	490	600	600
	1233-SS-04	7,100	6,200	2,200	7,200

Screening level for indoor air is $82 \mu\text{g}/\text{m}^3$ (RIASL₁₂ and TSRIASL₁₂)Screening level for soil-gas is $2700 \mu\text{g}/\text{m}^3$ (RIASL₁₂ and TSRIASL₁₂)**Summary of Results for Trichloroethene (TCE)**

Sample Type	Sample ID	Measured Concentration ($\mu\text{g}/\text{m}^3$)			
		May. 2017	Feb. 2018	Aug. 2018	Nov. 2018
		E1	E2	E3	E4
Outdoor Air	1233-OA-01	<0.45	<0.17	<0.18	<0.18
Indoor Air	1233-IA-01	<0.18	0.27	0.66	0.47
	1233-IA-02	<0.18	1.1	1.2	1.4
	1233-IA-03	<0.26	<0.17	0.57	0.28
	1233-IA-04	0.22	1.5	0.67	0.62
Sub-Slab Soil Gas	1233-SS-01	82	51	39	74
	1233-SS-02	8,600	6,800	5,800	7,600
	1233-SS-03	8.2	<4.2	<5.4	<4.4
	1233-SS-04	16,000	14,000	5,300	18,000

Screening levels for indoor air are $4 \mu\text{g}/\text{m}^3$ (RIASL₁₂) and $12 \mu\text{g}/\text{m}^3$ (TSRIASL₁₂)Screening levels for soil-gas are $130 \mu\text{g}/\text{m}^3$ (RIASL₁₂) and $400 \mu\text{g}/\text{m}^3$ (TSRIASL₁₂)

	RIASL ₁₂ Exceedance
	TSRIASL ₁₂ Exceedance

EVALUATION OF VI DATA TRENDS

Data trends for Building 1233 are discussed below for both sub-slab soil gas and indoor air. When data exhibit a narrow range of variability, it is typical practice to express the range as a percentage (e.g., relative percent difference [RPD]). When data exhibit a large range of variability, however, it is more useful to express the range in orders of magnitude (i.e., factors of 10). This can be expressed mathematically as the log of the ratio of maximum/minimum values. If the values differ by a factor of 10, the log of the ratio is 1, if the values differ by a factor of 100, the log of the ratio is 2, and so on.

The variability across all locations over all sampling events is the total variability. This encompasses different types of variability, including spatial variability (i.e., how do the results vary from location to location), temporal variability (i.e., how do the results at a given location vary over time), and measurement variability. Measurement variability can be determined by evaluating results of duplicate or collocated samples and includes both sampling variability and analytical variability.

Sub-Slab Soil Gas Data Trends

Spatial Variability of Sub-Slab Soil Gas – The soil gas exhibits up to three orders of magnitude of spatial variability. The spatial variability is the lowest during E3 for the seven analytes evaluated. Spatial variability for five out of the seven analytes (chloroform, HCBd, PCE, 1,1,2-TCA, and 1,2-DCP) was greatest in E2 (log max/min = ranges from 0.2 to 2). TCE saw its greatest spatial variability in sub-slab soil gas in E1 (log max/min = 3.3) and 1,2-DCA saw its greatest spatial variability in E4 (log max/min = 2.2). For five of the seven analytes, the second highest sub-slab soil gas spatial variability was observed in E1; thus indicating that E1 and E2 appear to have the greatest sub-slab soil gas spatial variability.

Temporal Variability of Soil Gas – The soil gas concentrations exhibit less than one order of magnitude of temporal variability (maximum log max/min = 0.55). Temporal variability is greatest at location 1233-SS-04 for six out of the seven analytes assessed (HCBd's temporal variability was greatest at 1233-SS-01). Based on this evaluation, there is a relatively modest amount of temporal variability in sub-slab soil gas which is in-line with expectations. Overall, as expected, the amount of temporal variability is less than the amount of spatial variability.

Seasonal Confirmation Sampling Trend Analysis – No formal statistical tests were performed, but the data exhibits relatively consistent results between the seasons. This is demonstrated by the graph below, which shows the seven analytes selected above at the location where they were detected at their highest concentrations (1233-SS-04). Note that the y-axis is a log scale.

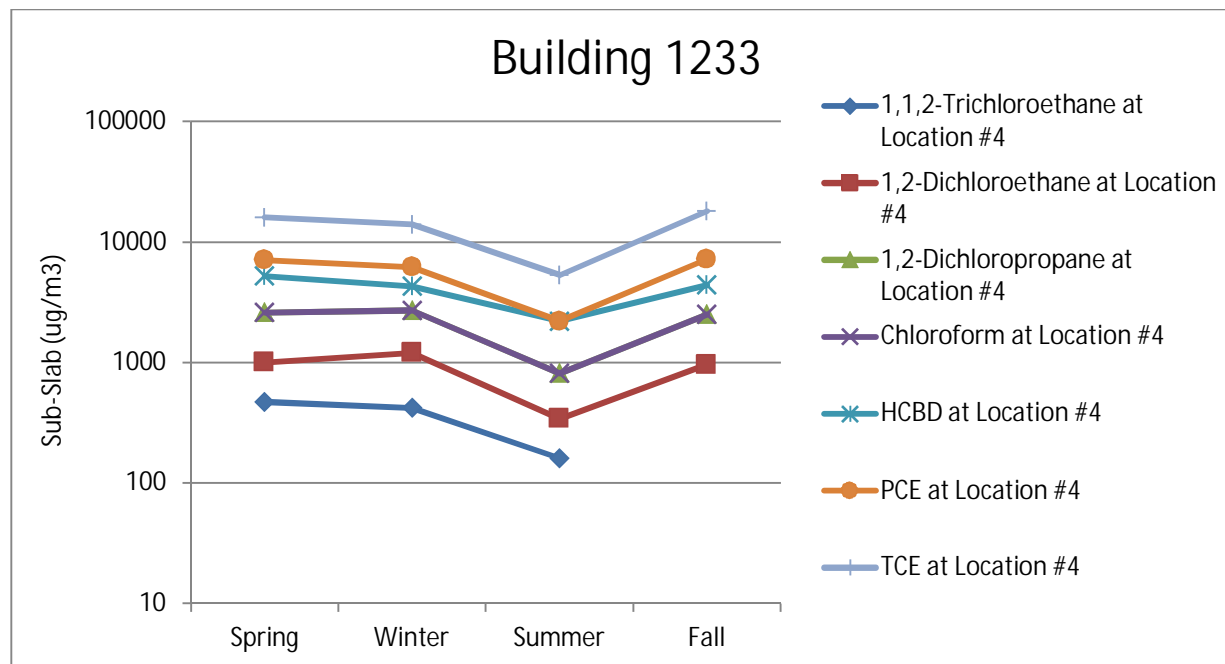

The data set was examined to see what the potential consequences would have been had only a single sampling event been performed. For the PCE and TCE, the highest sub-slab soil gas concentrations were collected during the fall (E4) and the lowest concentrations for all of the analytes graphed above occurred during the summer (E3). For chloroform, 1,2-DCA, and, 1,2-DCP the highest sub-slab concentration was collected during the winter (E2) and for HCBd and 1,1,2-TCA the highest result was in the spring (E1). Overall, the minimum and maximum values appear to be consistent between sampling events.

For TCE, a concentration of $16,000 \mu\text{g}/\text{m}^3$ was measured during E1 and the highest concentration ($18,000 \mu\text{g}/\text{m}^3$) was measured during E4. If only E1 had been performed, a negative bias of 13% would have been introduced (i.e., the E4 result was 13% higher than the E1 result). For PCE, a concentration of $7,100 \mu\text{g}/\text{m}^3$ was measured during E1 and the highest concentration ($7,200 \mu\text{g}/\text{m}^3$) was measured during E4. If only E1 had been performed, a negative bias of only 1% would have been introduced. The negative biases observed for chloroform, EDC, and 1,2-DCP fall within or only slight above the biases noted for PCE and TCE. Therefore, implementing four seasonal confirmation sampling events provided very limited insight regarding maximum concentration levels, but the larger data set served to increase the confidence in the findings including demonstrating the consistency of the maximum reported results.

Indoor Air Data Trends

Spatial Variability of Indoor Air – The indoor air concentrations exhibit less than one order of magnitude of spatial variability. Analytes EDC, TCE, and PCE were the only analytes from the seven above that had 100% detection frequency in indoor air during at least one sampling event and none of these results exceeded the project-specific RIASL₁₂. For the events where 1,2-DCA, TCE, and PCE had 100% detection frequency, spatial variability ranges were less than an order of magnitude (log max/min range from 0.02 to 0.7). TCE had 100% detection frequency during E3 and E4 and indoor air concentrations vary from 8.2 to $5.2 \mu\text{g}/\text{m}^3$ (log max./min. = 0.3) to 0.28 to $1.4 \mu\text{g}/\text{m}^3$ (log max./min. = 0.7), respectively. For PCE, the highest spatial variability occurred during E4 where indoor air concentrations vary from 1 to $2.9 \mu\text{g}/\text{m}^3$ (log max./min. = 0.5). The data suggests that the air is well mixed in the building.

Temporal Variability of Indoor Air – For the analytes that had 100% detection frequency in indoor air during at least one sampling event the temporal variability was around one order of magnitude of temporal variability (log max/min ranged from 0.1 to 1.1). For example, indoor air concentrations of TCE

at location 1233-IA-04 varied from 0.22 to 1.5 $\mu\text{g}/\text{m}^3$ (log of max./min. = 0.8). PCE at location 1233-IA-04 varied from 0.24 to 3.1 $\mu\text{g}/\text{m}^3$ (log of max./min. = 1.1). Overall, temporal variability across the four seasons sampled is relatively small.

Additional Analyses

Comparison of Sub-Slab Soil Gas and Indoor Air Data Sets – As expected, the sub-slab soil gas data exhibit greater spatial variability than the indoor air data set. Also as expected, the sub-slab soil gas exhibits less temporal variability than the indoor air data set.

Seasonal Effects – The sub-slab soil gas data exhibit relatively little variability from event to event. Maximum soil-gas values for PCE and TCE were detected during E4 (i.e., fall). The indoor air data set is predominantly ND values, but the highest PCE indoor air value occurred during E3 (i.e., summer) and for TCE the highest indoor air value occurred during E2 (i.e., winter). The highest 1,2-DCA concentration was observed during winter (E2) and the highest indoor air value occurred during E3 (summer). The data do not support the hypothesis that wintertime should have the highest indoor air impacts.

Comparison of Attenuation Factors by Event – Attenuation factors were calculated for TCE and PCE based on maximum values since both had a high detection frequencies in sub-slab soil gas and indoor air. The calculated event-specific attenuation factors are shown in Table 1233-3. PCE attenuation factors have been corrected to account for outdoor air detections in E2 and E3.

Table 1233-3. Comparison of Building-Specific Attenuation Factors by Event - TCE

	E1 (Spring)	E2 (Winter)	E3 (Summer)	E4 (Fall)
Maximum Values				
TCE in Sub-Slab Soil Gas ($\mu\text{g}/\text{m}^3$)	16,000	14,000	5,800	18,000
TCE in Indoor Air ($\mu\text{g}/\text{m}^3$)	0.22	1.5	1.2	1.4
Attenuation Factor	1.4E-05	1.1E-04	2.1E-04	7.8E-05
	E1 (Spring)	E2 (Winter)	E3 (Summer)	E4 (Fall)
Maximum Values				
PCE in Sub-Slab Soil Gas ($\mu\text{g}/\text{m}^3$)	7,100	6,200	3,700	7,200
PCE in Indoor Air ($\mu\text{g}/\text{m}^3$)	0.24	1.6	3.3	2.9
PCE in Outdoor Air ($\mu\text{g}/\text{m}^3$)	<0.22	0.73	2.4	<0.23
PCE Indoor Air Corrected ($\mu\text{g}/\text{m}^3$)	0.24	0.87	0.9	2.9
Attenuation Factor	<3.4E-5	1.4E-04	2.4E-04	4.0E-04

These serve as the best estimate of attenuation by event at Building 1233. The results can vary from day to day due to differences in rates of vapor intrusion and rates of building ventilation. Overall, the most conservative estimate of a building-specific attenuation factor for Building 1233 is 1.1E-04 based on TCE during E2.

Temporal Variability in Attenuation Factor – As shown in Table 1233-3, there slightly more than one order of magnitude of temporal variability in the calculated attenuation factors observed for TCE.

To be as conservative as possible, the maximum values were used in calculating the attenuation factor for each event. All maximum sub-slab soil gas values are from sample location 1233-SS-04 except for E3 when the highest result came from 1233-SS-02. The maximum indoor air values are from 1233-IA-04 and 1233-IA-02. In general, maximum concentrations were location-specific, but the low spatial variability in indoor air results means that roughly comparable attenuation factors would be obtained whichever indoor air value was used in the calculations.

NON-DETECT EVALUATION

Table 1233-4 below lists the analytes in sub-slab soil gas that have ND RLs greater than the screening levels. The table also includes the indoor air results for each of the analytes. If a sub-slab soil gas analyte has ND RL exceedances, but all results and ND RLs in indoor air are below the screening levels, no further evaluation is warranted. If an analyte was identified as an AOI in sub-slab soil gas (detected results > screening level), it is excluded from this ND evaluation. Also, if an ND analyte has an 0% detection frequency for all sampling events and all ND RLs met the screening level during at least one event, no further ND evaluation is warranted.

Table 1233-4. Non-Detect Evaluation for Building 1233

Soil Gas Analytes with ND RL > SL	Indoor Air Result Summary
1,1,2,2-Tetrachloroethane	0% Detection Frequency, All ND RLs < RIASL ₁₂
1,1,2-Trichloroethane	0% Detection Frequency, All ND RLs < RIASL ₁₂
1,2,4-Trichlorobenzene	0% Detection Frequency, 75% ND RLs < RIASL ₁₂ for E1 and E2, All ND RLs < TSRIASL ₁₂
1,2-Dibromoethane (EDB)	0% Detection Frequency, All ND RLs > RIASL ₁₂
alpha-Chlorotoluene	0% Detection Frequency, All ND RLs < RIASL ₁₂
Dibromochloromethane	0% Detection Frequency, All ND RLs < RIASL ₁₂
Dibromomethane	0% Detection Frequency, All ND RLs < RIASL ₁₂
Naphthalene	0% Detection Frequency, All ND RLs < RIASL ₁₂

WEIGHT-OF-EVIDENCE SUMMARY

Building 1233 was confirmed as a VI Path Forward Group 2 building due to its potential for VI based on sub-slab soil gas exceedances of the draft project-specific RIASL₁₂ and/or TSRIASL₁₂ for chloroform, TCE and PCE. However, after further investigation and evaluation, the following evidence supports the conclusion that VI is insignificant at Building 768:

- No exceedances of draft project-specific screening levels in indoor air.
- The sub-slab soil gas data do not show any strong time dependence nor do the data show any strong seasonal effects.
- The data do not support the hypothesis that wintertime should have the highest indoor air impacts. The highest sub-slab soil gas concentrations generally were measured in the fall. Similarly, the highest indoor air concentrations were measured in the summer and winter.
- This evaluation confirms that the sub-slab soil gas and indoor air concentrations were relatively constant from season to season.
- As shown in the table below, the building-specific attenuation factor yields estimated indoor air concentration for the maximum ND RL for EDB that is well below the screening level:

Parameters	EDB
Building-specific AF	1.1E-04
Maximum ND RL in SSSG (1233-SS-02)	<170
Estimated Indoor Air Concentration	0.019
Indoor Air ND RL at 1233-IA-04	<0.27
Indoor Air RIASL ₁₂	0.2

Based on the CSM for Building 1233, VI is an insignificant exposure pathway for current building utilization.

PATH FORWARD

Based on the evaluation of the four seasonal confirmation sampling events, the VI pathway continues to be insignificant for Building 1233 and the sub-slab soil gas results have demonstrated relatively stable concentrations and no evidence of increasing over time. Sufficient information exists to make a human exposure under control EI determination. However, while currently there is no evidence of potential VI, for future use, LTM is warranted and the building-specific Interim Monitoring Plan is discussed below.

Building-specific Interim Monitoring Plan

Dow implemented an interim monitoring plan at Building 1233 until a revised program or more permanent corrective action plan is developed for the site.

Indoor air is monitored at location 1233-IA-02 and 1233-IA-04. These locations were selected for continued monitoring since they demonstrated the highest sub-slab soil gas results. Monitoring is performed for 1,1,2-TCA, EDC, 1,2-DCP, chloroform, HCBd, PCE, and TCE. Interim monitoring occurs semi-annually and the initial event was conducted in August 2019. The indoor air results are shown below.

Indoor Air Analyte	Result Value ($\mu\text{g}/\text{m}^3$)	Reporting Limit ($\mu\text{g}/\text{m}^3$)	EGLE Project-Specific RIASL ₁₂ ($\mu\text{g}/\text{m}^3$)	NONRES TSRIASL ₁₂ ($\mu\text{g}/\text{m}^3$)	Dow IH OEL (8hr Time Weighted Average) ($\mu\text{g}/\text{m}^3$)
<i>Sample 1233-IA-02</i>					
1,1,2-Trichloroethane	ND	0.17	0.62	NA	54,600
1,2-Dichloroethane	0.86	0.13	4.6	NA	4,050
1,2-Dichloropropane	ND	0.73	12.2	NA	46,200
Chloroform	2.4	0.77	5.2	52	9,760
Hexachlorobutadiene	ND	8.4	5.4	NA	213.4
Tetrachloroethene	6.4	0.21	82	82	67,800
Trichloroethene	4.4	0.17	4	12	26,850
<i>Sample 1233-IA-04</i>					
1,1,2-Trichloroethane	ND	0.18	0.62	NA	54,600
1,2-Dichloroethane	0.65	0.14	4.6	NA	4,050
1,2-Dichloropropane	ND	0.78	12.2	NA	46,200
Chloroform	2.4	0.82	5.2	52	9,760
Hexachlorobutadiene	ND	9	5.4	NA	213.4
Tetrachloroethene	5.2	0.23	82	82	67,800
Trichloroethene	1.7	0.18	4	12	26,850

As shown on the table above, all indoor air results from the Summer 2019 IM event were below the indoor air RIASL₁₂, with the exception TCE at 1233-IA-02 which had a result ($4.4 \mu\text{g}/\text{m}^3$) slightly above the RIASL₁₂. Due to this exceedance of TCE, co-located samples were collected at 1233-02 in November 2019 and the results will be discussed in an early 2020 corrective action status meeting. The next IM event is scheduled for Winter 2019/2020. Semi-annual interim monitoring will continue in the summer and winter of 2020. The analytical data is presented in Appendix A. Field sampling logs are provided in Appendix B.

5.3.5 VI Seasonal Confirmation Sampling Results Evaluation for Building 827

INTRODUCTION

Building 827 is a Category 1 building located in the central portion of the facility designated as Zone 2 (Figure 5.3.5-1). It is known as the Growth Insecticides Building and is a large two-story building that includes office space, a laboratory, shop, and warehouse space.

The initial evaluation in the 2017 CAIP placed Building 827 in VI Path Forward Building Group 2 due to sub-slab soil gas exceedances and the building was placed into seasonal confirmation sampling. The results of E1 through E3 were re-evaluated in the 2018 Rescreen Report and in Section 5.2.9 of the 2018 CAIP. Building 827 was placed into Group 4A due to indoor air exceedances likely resulting from workplace chemical use. Since that time, additional seasonal events (E4, E5, E6, and E7) and a further investigation with a mobile GC unit have been completed. Email notifications were provided to EGLE in January, April, July, and October 2019. The results of all completed events are summarized and included in this evaluation.

Building 827	
Initial Sampling Event	Completed
E1	May 2017 (Spring)
Seasonal Sampling Event	Completed
E2	February/March 2018 (Winter)
E3	August 2018 (Summer)
E4	October 2018 (Fall)
E5	February 2019 (Winter)
E6	April 2019 (Spring)
E7	August 2019 (Summer)

TCE was detected in indoor air above the TSRIASL₁₂ at a single sample location during the initial sampling event (E1). During all six subsequent rounds of seasonal sampling, TCE was detected below the draft project-specific TRIASL₁₂ at all 14 sample locations, including the location of the initial exceedance. Therefore, no Expedited Building Summary was necessary.

SUB-SLAB SOIL GAS RESULTS EVALUATION

During the first four sampling events, sub-slab soil gas samples were collected from 14 locations from within the building. For the three subsequent sampling events in 2019, sub-slab soil gas samples were collected from the five locations of greatest interest. Indoor air samples were collected at locations corresponding to the soil gas sample locations. Two outdoor air samples were collected during each event from the main air intakes, except for E7 (only one outdoor air sample was collected). The sampling locations are shown on Figure 5.3.5-2. Summary statistics and screening comparison results are presented for sub-slab soil gas on Table 5.3.5-A and indoor and outdoor air on Table 5.3.5-B. The analytical data is presented in Appendix A. The field sampling logs are presented in Appendix B.

Table 827-1 presents the sub-slab soil gas results that exceed the draft project-specific screening levels. TCE and PCE also had exceedances greater than the sub-slab soil gas TSRIASL₁₂.

Table 827-1. Summary of Sub-Slab Soil Gas Exceedances for Building 827

Analyte (Sampling Event)	Detection Frequency	Measured Range of Detects ($\mu\text{g}/\text{m}^3$)	% Detections > Screening Level	Screening Level* ($\mu\text{g}/\text{m}^3$)
Tetrachloroethene (1)	100%	28 - 170,000	29%	2,700
Tetrachloroethene (2)	100%	18 - 240,000	29%	2,700
Tetrachloroethene (3)	100%	13 - 240,000	21%	2,700
Tetrachloroethene (4)	100%	19 - 190,000	21%	2,700
Tetrachloroethene (5)	100%	28 - 190,000	60%	2,700
Tetrachloroethene (6)	100%	23 - 180,000	60%	2,700
Tetrachloroethene (7)	100%	25 - 190,000	60%	2,700
Trichloroethene (1)	43%	4 - 1,100	14%	130
Trichloroethene (2)	29%	28 - 1,900	21%	130
Trichloroethene (3)	43%	6.8 - 1,700	14%	130
Trichloroethene (4)	29%	14 - 1,300	14%	130
Trichloroethene (5)	60%	4 - 1,400	40%	130
Trichloroethene (6)	40%	160 - 920	40%	130
Trichloroethene (7)	60%	42 - 1,400	40%	130

*Screening level provided is the draft project-specific RIASL₁₂.

Table 827-2 summarizes the indoor air results relative to the sub-slab soil gas exceedances, since VI only potentially occurs if the analyte is present in both sub-slab soil gas and indoor air. Therefore, the table below provides the analytes detected above applicable screening levels in sub-slab soil gas as well as the corresponding indoor air sample results. The outdoor air sample results are also provided to determine if the analytes were present in indoor air due to migration from outdoor air.

Table 827-2. Vapor Intrusion Evaluation for Building 827

Analyte	Indoor Air Detection Frequency	Indoor Air Measured Range ($\mu\text{g}/\text{m}^3$)	Indoor Air Screening Level* ($\mu\text{g}/\text{m}^3$)	Outdoor Air Result ($\mu\text{g}/\text{m}^3$)
Tetrachloroethene (1)	93%	0.21 - 9.5	82	ND
Tetrachloroethene (2)	100%	0.47 - 6.5	82	4.2
Tetrachloroethene (3)	100%	1.6 - 2.9	82	1.9
Tetrachloroethene (4)	100%	0.69 - 2.7	82	2.1
Tetrachloroethene (5)	100%	0.86 - 3.3	82	0.97
Tetrachloroethene (6)	100%	.48 - 2.8	82	ND
Tetrachloroethene (7)	100%	0.78 - 1.3	82	0.33
Trichloroethene (1)	100%	0.19 - 32	4	ND
Trichloroethene (2)	100%	0.26 - 1.6	4	ND
Trichloroethene (3)	7%	4	4	ND
Trichloroethene (4)	100%	0.54 - 7.9	4	ND
Trichloroethene (5)	100%	0.28 - 9.1	4	ND
Trichloroethene (6)	40%	0.2 - 1	4	ND
Trichloroethene (7)	20%	1.4	4	ND

*Screening level provided is the draft project-specific RIASL₁₂.

TCE was detected in indoor air above the draft project-specific RIASL₁₂ in two sample locations (locations 827-IA-04 and 827-IA-14) during the initial sampling event. TCE was about two orders of magnitude lower at 827-IA-04, which is within a small women's restroom, during all six subsequent sampling events and was below detection limits several times. For 827-IA-14, which is an instrument shop, TCE was detected at or above the RIASL₁₂ for three of the six subsequent sampling events.

Sub-slab soil gas and indoor air results for each sample location and sampling event is provided for TCE on Figure 827-1. The indoor air results for TCE occurred at two locations where the soil gas concentrations were ND or below the screening level, which indicates that the source of the TCE detected

in indoor air is not the soil gas immediately beneath the sampling location. PCE exhibits a similar trend of somewhat higher indoor air concentrations at locations -04 and -14, but relatively low soil gas concentrations at these same locations. These results suggest that the indoor air impacts are not attributable to VI and are likely due to workplace chemical use.

Other VOCs were detected in indoor air but do not appear to be attributable to VI. For example, 1,1,2-TCA, chloroform, and ethylbenzene were also detected in indoor air above the draft project-specific RIASL₁₂ during the initial sampling event, but all results were below their respective TSRIASL₁₂. None of these analytes were detected above the RIASL₁₂ in sub-slab soil gas during any of the sampling events; therefore, indoor air detections are likely due to workplace chemical use and not attributable to VI.

Additional investigations were undertaken at Building 827 during May and July 2019 and were reported in the October 2019 Summary of Investigative Findings (see Appendix C) which made use of a field GC capable of detecting TCE at relatively low concentrations. Overall, the weight of evidence collected throughout these investigations confirm that the elevated TCE and chloroform concentrations in Building 827 are due to active workplace chemical use and not attributable to VI. Cans of Heavy Duty Flash Free Electrical Solvent (i.e., degreaser) containing over 90% TCE were stored in the building at multiple locations. The investigations determined that the frequent use of degreasers is the main source of the elevated TCE concentrations in the garage. TCE and chloroform concentrations were low throughout the majority of areas in Building 827, including the administrative area and offices in the western portion of the building, with the exception of the identification of a dry water trap in the drain of the instrument shop. Once the trap was filled with water, the depressurization test results indicated that the elevated TCE and chloroform concentrations measured from the drain were likely not attributable to VI, and more likely originated from sewer gas in the dry trap. The drains in the women's restroom were also determined to not be a source, as there were no differences detected during depressurization tests versus baseline conditions. A depressurization test was also conducted in the office area (827-11) and it demonstrated that there are no viable pathways for the underlying sub-slab soil gas to vent into indoor air of the office.

VAPOR INTRUSION CONCEPTUAL SITE MODEL

VI is an exposure pathway that results from the migration of volatilized chemicals from the subsurface to indoor air in overlying occupied buildings. A source, migration route and a human receptor must be present for the VI pathway to be complete. The focus of this building specific investigation is to evaluate the potential VI exposure pathway for employees and contractors at Building 827. The CSM is illustrated in Figure 5.3.5-3.

Building 827 is known as the Growth Insecticides Building and is a large two-story building that includes office space, a laboratory, shop, and warehouse space. Approximately 30-40 admin personnel occupy Building 827 from 8am to 5pm Monday through Friday and approximately 20-40 operations personnel occupy the building 24 hours a day, seven days a week (8-hour shifts during the week and 12-hour shifts over the weekend). The typical parameters for non-residential exposures are assumed to apply to the various personnel stationed during rotating work shifts at this building (i.e., 40 hours/week, 50 weeks/year exposure).

The building survey completed before the initial sampling event. Drains and other openings were screened with a PID and no soil gas entry points were identified. A chemical inventory was completed during the building survey and the chemicals found to be stored within the building and included degreasers, cleaners, rain and stain protector, penetration catalysts, rust breakers, heavy duty traffic paint, and lithium chloride.

EVALUATION OF SEASONAL CONFIRMATION SAMPLING EVENTS

Seven seasonal sampling events have been completed at Building 827. The sampling events encompass more than two years of time and include sampling during each season of the year. The

results from the four seasonal confirmation sampling events were evaluated with respect to spatial variability, temporal variability, and seasonal trend analysis.

Building specific attenuation factors (α) were calculated and compared between events to evaluate temporal variability and determine the best estimate of a building-specific attenuation factor. This evaluation serves to confirm that the existing study design is appropriate, and also provides insight for the determination of the path forward for this building.

This evaluation focused on any analytes detected in the sub-slab soil gas samples that met the criterion for inclusion in one or more of the following categories:

- a) Analytes detected in sub-slab soil-gas at concentrations that exceeded draft project-specific screening levels;
- b) Analytes detected in sub-slab soil-gas at concentrations of $1,000 \mu\text{g}/\text{m}^3$ or greater in one or more samples. Data for analytes detected above $1,000 \mu\text{g}/\text{m}^3$ should provide the clearest signal and be the simplest to interpret when assessing data trends. The same data trends observed for these analytes are expected to apply to other similar analytes present at lower concentrations; and
- c) PCE and TCE. These two analytes are of particular interest for many VI evaluations at industrial sites.

For this building, the analytes detected in the sub-slab soil gas at concentrations above the draft project-specific screening levels were PCE and TCE. The only other VOCs detected in any soil-gas sample at concentrations $>1,000 \mu\text{g}/\text{m}^3$ were CFC-12, 1,1,1-TCA, and acetone. 2,2,4-Trimethylpentane and chlorobenzene were only detected in a single location during a single event $>1,000 \mu\text{g}/\text{m}^3$ so they are not included in this evaluation. Sample results for the five analytes are provided in the following data tables below:

Summary of Results for 1,1,1- Trichloroethane (1,1,1-TCA)

Sample Type	Sample ID	Measured Concentration ($\mu\text{g}/\text{m}^3$)						
		May 2017	Feb./Mar 2018	Aug. 2018	Oct. 2018	Feb. 2019	Apr. 2019	Aug. 2019
		E1	E2	E3	E4	E5	E6	E7
Outdoor Air	827-OA-01	<0.19	<0.19	<0.21	<0.17	--	--	<0.20
	827-OA-02	<0.18	<0.18	<0.20	<0.18	--	--	--
Indoor Air	827-IA-01	<0.18	<0.18	<0.19	<0.20	--	--	--
	827-IA-02	<0.17	<0.18	<0.18	<0.19	--	--	--
	827-IA-03	<0.17	<0.18	<0.17	<0.18	--	--	--
	827-IA-04	<1.5	<0.19	<0.18	<0.18	--	--	<0.18
	827-IA-05	<0.16	<0.18	<0.19	<0.18	--	--	--
	827-IA-06	<0.18	<0.19	<0.18	<0.18	--	--	--
	827-IA-07	<0.17	<0.18	<0.18	<0.18	--	--	--
	827-IA-08	<0.18	<0.18	<0.18	<0.18	--	--	--
	827-IA-09	<0.18	0.30	<0.19	0.21	--	--	--
	827-IA-10	<0.16	0.18	<0.19	0.20	--	--	--
	827-IA-11	<0.19	<0.19	<0.19	<0.19	--	--	<0.19
	827-IA-12	<0.18	0.20	<0.21	<0.20	--	--	<0.19
	827-IA-13	<0.20	0.19	<0.19	<0.18	--	--	<0.18
	827-IA-14	4.3	<0.17	0.60	<0.18	--	--	0.27
Sub-Slab Soil Gas	827-SS-01	320	250	88	170	--	--	--
	827-SS-02	260	180	68	170	--	--	--
	827-SS-03	210	220	250	210	--	--	--
	827-SS-04	260	74	260	240	--	--	160
	827-SS-05	7.6	7.4	7.2	4.6	--	--	--
	827-SS-06	140	120	99	100	--	--	--
	827-SS-07	<4.5	<4.4	<4.4	<4.3	--	--	--
	827-SS-08	6.7	5.4	<4.4	<4.3	--	--	--
	827-SS-09	310	210	330	290	--	--	--
	827-SS-10	85	79	130	42	--	--	--
	827-SS-11	<260	<150	<40	<110	--	--	<83
	827-SS-12	<86	<84	<45	<44	--	--	<43
	827-SS-13	<220	<150	<210	<110	--	--	<88
	827-SS-14	1,100	840	34	700	--	--	250

Screening levels for indoor air are 7000 $\mu\text{g}/\text{m}^3$ (RIASL12 and TSRIASL12)

Screening level for soil-gas is 230000 $\mu\text{g}/\text{m}^3$ (RIASL₁₂ and TSRIASL12)

	RIASL12 Exceedance
	TSRIASL12 Exceedance

Summary of Results for Acetone

Sample Type	Sample ID	Measured Concentration (µg/m ³)						
		May 2017	Feb./Mar 2018	Aug. 2018	Oct. 2018	Feb. 2019	Apr. 2019	Aug. 2019
		E1	E2	E3	E4	E5	E6	E7
Outdoor Air	827-OA-01	19	13	27	17	--	--	70
	827-OA-02	14	12	17	23	--	--	--
Indoor Air	827-IA-01	39	77	91	66	--	--	--
	827-IA-02	120	74	130	64	--	--	--
	827-IA-03	72	68	66	64	--	--	--
	827-IA-04	66	640	290	540	--	--	1,000
	827-IA-05	25	61	82	47	--	--	--
	827-IA-06	27	59	110	58	--	--	--
	827-IA-07	29	38	84	36	--	--	--
	827-IA-08	24	52	88	53	--	--	--
	827-IA-09	66	50	23	67	--	--	--
	827-IA-10	110	33	48	180	--	--	--
	827-IA-11	17	39	22	31	--	--	490
	827-IA-12	21	37	17	110	--	--	1,300
	827-IA-13	17	35	20	22	--	--	57
	827-IA-14	84	26	56	21	--	--	120
Sub-Slab Soil Gas	827-SS-01	35	24	60	60	--	--	--
	827-SS-02	30	28	120	45	--	--	--
	827-SS-03	43	41	61	24	--	--	--
	827-SS-04	68	64	24	57	--	--	260
	827-SS-05	67	26	48	100	--	--	--
	827-SS-06	42	36	51	51	--	--	--
	827-SS-07	45	46	71	46	--	--	--
	827-SS-08	28	33	54	230	--	--	--
	827-SS-09	200	180	210	<260	--	--	--
	827-SS-10	130	260	300	180	--	--	--
	827-SS-11	<460	<260	77	<190	--	--	<140
	827-SS-12	<370	<360	81	<76	--	--	2,700
	827-SS-13	<380	<260	<370	210	--	--	<150
	827-SS-14	220	250	280	190	--	--	1,800

Screening levels for indoor air are 31000 µg/m³ (RIASL12 and TSRIASL12)

Screening level for soil-gas is 1000000 µg/m³ (RIASL₁₂ and TSRIASL12)

	RIASL12 Exceedance
	TSRIASL12 Exceedance

Summary of Results for Chlorofluorocarbon (CFC-12)

Sample Type	Sample ID	Measured Concentration ($\mu\text{g}/\text{m}^3$)						
		May 2017	Feb./Mar 2018	Aug. 2018	Oct. 2018	Feb. 2019	Apr. 2019	Aug. 2019
		E1	E2	E3	E4	E5	E6	E7
Outdoor Air	827-OA-01	2.3	2.5	2.2	1.7	--	--	1.8
	827-OA-02	2.3	2.5	2.2	1.7	--	--	--
Indoor Air	827-IA-01	2.4	2.7	2.4	2.1	--	--	--
	827-IA-02	2.3	2.7	2.4	2.1	--	--	--
	827-IA-03	2.3	2.8	2.4	2	--	--	--
	827-IA-04	2.6	2.6	2.3	1.9	--	--	1.8
	827-IA-05	2.2	2.8	2.4	1.9	--	--	--
	827-IA-06	2.4	2.7	2.3	1.9	--	--	--
	827-IA-07	2.4	2.8	2.4	1.9	--	--	--
	827-IA-08	2.4	2.7	2.4	1.8	--	--	--
	827-IA-09	2.8	3.9	2.4	2.4	--	--	--
	827-IA-10	2.7	3.4	2.3	2.3	--	--	--
	827-IA-11	2.5	3.5	2.4	2	--	--	1.8
	827-IA-12	2.6	3.6	2.4	2	--	--	1.9
	827-IA-13	2.5	3.3	2.6	2	--	--	1.9
	827-IA-14	2.4	2.5	2.3	1.8	--	--	1.9
Sub-Slab Soil Gas	827-SS-01	68	1984	12	13	--	--	--
	827-SS-02	560	350	94	250	--	--	--
	827-SS-03	900	1000	690	410	--	--	--
	827-SS-04	220	95	70	54	--	--	14
	827-SS-05	5	4	5.3	5.1	--	--	--
	827-SS-06	29	28	19	14	--	--	--
	827-SS-07	4.4	5.6	6.8	6.4	--	--	--
	827-SS-08	6.1	7.9	5	5	--	--	--
	827-SS-09	11,000	10,000	12,000	14,000	--	--	--
	827-SS-10	890	2,200	850	420	--	--	--
	827-SS-11	5,000	5,200	1,000	5,000	--	--	5,600
	827-SS-12	6,200	8,300	5,400	6,300	--	--	5,700
	827-SS-13	2,300	2,300	1,500	2,500	--	--	2,700
	827-SS-14	86	84	6.1	180	--	--	88

Screening level for indoor air is 1,020 $\mu\text{g}/\text{m}^3$ (RIASL₁₂)

Screening level for soil-gas is 34,000 $\mu\text{g}/\text{m}^3$ (RIASL₁₂)

	RIASL12 Exceedance
	TSRIASL12 Exceedance

Summary of Results for Tetrachloroethene (PCE)

Sample Type	Sample ID	Measured Concentration ($\mu\text{g}/\text{m}^3$)						
		May 2017	Feb./Mar 2018	Aug. 2018	Oct. 2018	Feb. 2019	Apr. 2019	Aug. 2019
		E1	E2	E3	E4	E5	E6	E7
Outdoor Air	827-OA-01	<0.24	0.24	1.9	0.59	<0.20	<0.23	0.33
	827-OA-02	<0.23	4.2	1.7	2.1	0.97	<0.22	--
Indoor Air	827-IA-01	0.29	0.64	2.6	1.5	--	--	--
	827-IA-02	0.52	0.47	2.5	1.5	--	--	--
	827-IA-03	0.29	0.51	2.6	2.7	--	--	--
	827-IA-04	9.5	0.49	2.8	1.5	0.86	0.53	1.3
	827-IA-05	0.43	0.65	2.8	1.8	--	--	--
	827-IA-06	0.30	0.49	2.8	1.4	--	--	--
	827-IA-07	0.29	0.48	2.7	1.8	--	--	--
	827-IA-08	0.32	0.55	2.9	2	--	--	--
	827-IA-09	0.26	3.8	1.7	2.3	--	--	--
	827-IA-10	0.21	3.6	1.6	2.3	--	--	--
	827-IA-11	0.29	6.5	2.2	2	3.3	2.2	0.99
	827-IA-12	0.48	4.7	2	2.2	1.2	0.48	0.80
	827-IA-13	<0.25	4.1	2.9	1.8	1.2	0.59	0.78
	827-IA-14	2.9	3.3	2.4	0.69	2.9	2.8	1.2
Sub-Slab Soil Gas	827-SS-01	66	68	31	55	--	--	--
	827-SS-02	28	18	13	19	--	--	--
	827-SS-03	76	90	86	70	--	--	--
	827-SS-04	58	31	50	49	28	23	25
	827-SS-05	200	210	200	130	--	--	--
	827-SS-06	460	510	390	390	--	--	--
	827-SS-07	170	170	160	150	--	--	--
	827-SS-08	170	140	140	150	--	--	--
	827-SS-09	620	450	900	2500	--	--	--
	827-SS-10	310	440	670	500	--	--	--
	827-SS-11	160,000	220,000	41,000	180,000	130,000	180,000	170,000
	827-SS-12	20,000	28,000	21,000	19,000	14,000	8,800	14,000
	827-SS-13	170,000	240,000	240,000	190,000	190,000	50,000	190,000
	827-SS-14	3,600	3,300	160	2,500	2,100	2,100	1,700

Screening level for indoor air is $82 \mu\text{g}/\text{m}^3$ (RIASL₁₂ and TSRIASL₁₂)

Screening level for soil-gas is $2,700 \mu\text{g}/\text{m}^3$ (RIASL₁₂ and TSRIASL₁₂)

	RIASL12 Exceedance
	TSRIASL12 Exceedance

Summary of Results for Trichloroethene (TCE)

Sample Type	Sample ID	Measured Concentration ($\mu\text{g}/\text{m}^3$)						
		May 2017	Feb./Mar 2018	Aug. 2018	Oct. 2018	Feb. 2019	Apr. 2019	Aug. 2019
		E1	E2	E3	E4	E5	E6	E7
Outdoor Air	827-OA-01	<0.19	<0.18	<0.20	0.40	<0.16	<0.18	<0.20
	827-OA-02	<0.18	<0.18	<0.19	0.33	<0.17	<0.18	--
Indoor Air	827-IA-01	0.20	0.45	<0.19	0.54	--	--	--
	827-IA-02	0.23	0.48	<0.18	0.59	--	--	--
	827-IA-03	0.19	0.45	<0.17	0.60	--	--	--
	827-IA-04	32	0.51	<0.18	0.58	0.28	0.20	<0.18
	827-IA-05	0.20	0.46	<0.19	0.67	--	--	--
	827-IA-06	0.21	0.40	<0.18	0.57	--	1	--
	827-IA-07	0.23	0.41	<0.18	0.75	--	--	--
	827-IA-08	0.23	0.43	<0.18	0.62	--	--	--
	827-IA-09	0.21	0.60	<0.18	2	--	--	--
	827-IA-10	0.26	0.41	<0.19	1.8	--	--	--
	827-IA-11	0.20	0.44	<0.18	7.9	1.3	<0.19	<0.18
	827-IA-12	0.19	0.52	<0.20	5	0.91	<0.18	<0.19
	827-IA-13	0.27	0.26	<0.18	1.9	0.97	<0.17	<0.18
	827-IA-14	12	1.6	4	7.4	9.1	1	1.4
Sub-Slab Soil Gas	827-SS-01	4	<4.7	<4.3	<4.5	--	--	--
	827-SS-02	<4.5	<4.4	<4.1	<4.5	--	--	--
	827-SS-03	<4.2	<4.2	<4.4	<4.2	--	--	--
	827-SS-04	110	28	22	14	4	<4.2	<4.4
	827-SS-05	<4	<4.3	9.7	<4.2	--	--	--
	827-SS-06	<3.9	<4.5	<4.3	<4.3	--	--	--
	827-SS-07	<4.4	<4.3	<4.3	<4.2	--	--	--
	827-SS-08	5.2	<4.5	<4.3	<4.2	--	--	--
	827-SS-09	<45	<33	44	<60	--	--	--
	827-SS-10	<4.4	<8.5	6.8	<4.3	--	--	--
	827-SS-11	1,100	1,500	280	840	670	920	840
	827-SS-12	86	140	77	60	<56	<41	42
	827-SS-13	920	1,900	1,700	1,300	1,400	160	1,400
	827-SS-14	<8.6	<8.4	<4	<11	<8	<8.3	<4.1

Screening levels for indoor air are $4 \mu\text{g}/\text{m}^3$ (RIASL₁₂) and $12 \mu\text{g}/\text{m}^3$ (TSRIASL₁₂)
Screening levels for soil-gas are $130 \mu\text{g}/\text{m}^3$ (RIASL₁₂) and $400 \mu\text{g}/\text{m}^3$ (TSRIASL₁₂)

	RIASL12 Exceedance
	TSRIASL12 Exceedance

EVALUATION OF VI DATA TRENDS

Data trends for Building 827 are discussed below for both sub-slab soil gas and indoor air. When data exhibit a narrow range of variability, it is typical practice to express the range as a percentage. When data exhibit a large range of variability, however, it is more useful to express the range in orders of magnitude (i.e., factors of 10). This can be expressed mathematically as the log of the ratio of maximum/minimum values. If the values differ by a factor of 10, the log of the ratio is 1, if the values differ by a factor of 100, the log of the ratio is 2, and so on.

The variability across all locations over all sampling events is the total variability. This encompasses different types of variability, including spatial variability (i.e., how do the results vary from location to location), temporal variability (i.e., how do the results at a given location vary over time), and measurement variability. Measurement variability can be determined by evaluating results of duplicate or collocated samples and includes both sampling variability and analytical variability. The comparison of

two data values is typically expressed as a RPD. The comparison of three or more data values is typically expressed as the %CV, which is the standard deviation divided by the mean.

Sub-Slab Soil Gas Data Trends

Spatial Variability of Sub-Slab Soil Gas – The sub-slab soil gas exhibits up to four orders of magnitude of spatial variability. For example, sub-slab soil gas detections of PCE vary from 13 to 240,000 $\mu\text{g}/\text{m}^3$ (log of max./min. = 4.3) across the 14 locations for E3. Very similar variability was observed for PCE during all seven sampling events (log of max./min. ranging from 3.8 to 4.3). Other VOCs were present at lower maximum concentrations in the sub-slab soil gas and exhibited somewhat less spatial variability. During E3, for example, CFC-12 ranged from 5 to 12,000 $\mu\text{g}/\text{m}^3$ (log of max./min. = 3.4) and TCE ranged from <4 to 1,700 $\mu\text{g}/\text{m}^3$ (log of max./min. = >2.6).

Temporal Variability of Sub-Slab Soil Gas – At locations with the highest sub-slab soil gas concentrations, the temporal variability was at most about a factor of five across the seven sampling events (e.g., PCE at SS-13 ranged from 50,000 to 240,000 $\mu\text{g}/\text{m}^3$). In general, the results were relatively stable over the sampling events. For some VOCs at locations with relatively low concentrations, however, the data exhibits more than an order of magnitude of temporal variability. For example, sub-slab soil gas concentrations of 1,1,1-TCA vary from 34 to 1,100 $\mu\text{g}/\text{m}^3$ at location SS-14 (log max/min = 1.5) across five sampling events.

Seasonal Confirmation Sampling Trend Analysis – No formal statistical tests were performed but the sub-slab soil gas data at locations with the highest concentrations generally do not exhibit any upward or downward trend over the course of the eight sampling events. This is illustrated in the graph below, which shows results for several locations with relatively high concentrations for analytes detected at the highest concentrations. Note that the y-axis is a log scale.

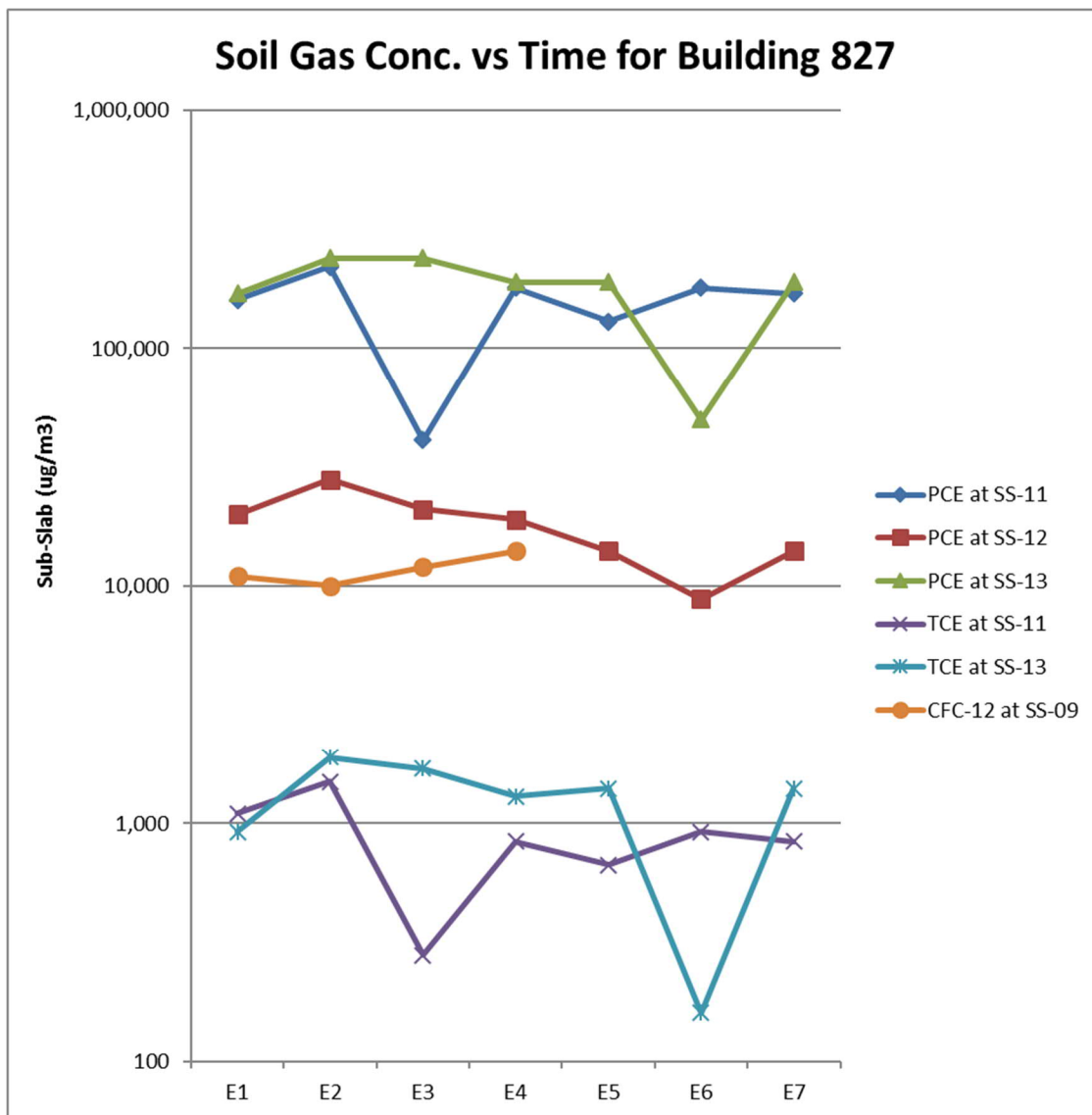

The data set was examined to see what the potential consequences would have been had only a single sampling event been performed. For the analytes present at the highest concentrations in the sub-slab soil gas (i.e., PCE and TCE), the maximum sub-slab soil gas concentration was obtained during E2 (winter) or E3 (summer). For TCE at location SS-13, the value increased from 920 during E1 to 1,900 during E2. If only the first sampling event had been performed, a negative bias of a factor of 2X would have been introduced (i.e., the TCE value for E2 was about twice as high as the TCE value for E1).

Indoor Air Data Trends

Spatial Variability of Indoor Air – The indoor air exhibits one to two orders of magnitude of spatial variability during some of the sampling events. For example, TCE was detected in all 14 indoor air samples and varied from 0.19 to 32 µg/m³ during E1 (log max./min. = 2.2). During that same sampling event, PCE varied from 0.21 to 9.5 µg/m³ (log max./min. = 1.7). The variability was generally less during subsequent sampling events.

Temporal Variability of Indoor Air – The detected values for TCE exhibit temporal variability of up to two orders of magnitude over time. For example, TCE was detected during five of seven sampling events at location 827-IA-04 and the values ranged from 0.20 to 32 µg/m³. Acetone also exhibited about two

orders of magnitude temporal variability, with values at 827IA-12 ranging from 17 to 1,300 $\mu\text{g}/\text{m}^3$. For PCE, the variability over time was up to about one order of magnitude. For example, PCE was detected during all seven sampling events at location 827-IA-04, with values ranging from 0.49 to 9.5 $\mu\text{g}/\text{m}^3$.

Additional Analyses

Comparison of Sub-Slab Soil Gas and Indoor Air Data Sets – As expected, the sub-slab soil gas data exhibit greater spatial variability than the indoor air data set. Also as expected, the sub-slab soil gas data had lower temporal variability than the indoor air data.

Seasonal Effects –The highest indoor air concentration for PCE, TCE, and acetone were all measured in the summer sampling events. The data indicate that any wintertime “stack effects” across the slab are not significant compared with indoor emission sources and/or VI at other seasons of the year.

Comparison of Attenuation Factors by Event – Attenuation factors were calculated based on maximum values and are shown in Table 827-3. The highest soil gas concentrations, by far, were for PCE. The values in Table 1 have not been corrected for any contribution from outdoor air. If outdoor air values were subtracted from indoor air values, the attenuation factors for CFC-12 and for acetone would be lower.

Calculated Attenuation Factors

	E1	E2	E3	E4	E5	E6	E7
Evaluation Based on Maximum Detected Value							
PCE	5.6E-05	2.7E-05	1.2E-05	1.4E-05	1.7E-05	1.6E-05	6.8E-06
TCE	2.9E-02	8.4E-04	2.4E-03	6.1E-03	6.5E-03	1.1E-03	1.0E-03
1,1,1-TCA	3.9E-03	3.6E-04	2.3E-03	3.0E-04	NC	NC	1.1E-03
CFC-12	2.6E-04	3.6E-04	2.2E-04	1.7E-04	NC	NC	3.3E-04
Acetone	3.8E-01	>1	>1	>1	NC	NC	4.8E-01

NC - Not calculated due to no detections in soil gas during that round of testing.

The tabulated attenuation factors for PCE are thought to best represent potential VI at this building. The calculated attenuation rates for other VOCs were significantly higher, presumably due to the contributions from indoor emission sources.

Temporal Variability in Attenuation Factor – As shown in Table 1, there was very little difference in the calculated attenuation factor for PCE from sampling event to sampling event. There is no apparent seasonal variability or long-term trend.

NON-DETECT EVALUATION

Table 827-3 below lists the analytes in sub-slab soil gas that have ND RLs greater than the screening levels. The table also includes the indoor air result summary for each of the analytes. If a sub-slab soil gas analyte has ND RL exceedances, but all results and ND RLs in indoor air are below the screening levels, no further evaluation is warranted. If an analyte was identified as an AOI in sub-slab soil gas (detected results > screening level), it is excluded from the ND evaluation. Also, if an ND analyte has an 0% detection frequency for all sampling events and all ND RLs met the screening level during at least one event, no further ND evaluation is warranted.

Table 827-3. Non-Detect Evaluation for Building 827

Soil Gas Analytes with ND RL > SL	Indoor Air Result Summary
1,1,2,2-Tetrachloroethane	0% Detection Frequency, All ND RLs < RIASL ₁₂
1,1,2-Trichloroethane	14% Detection Frequency, All detects and ND RLs < RIASL ₁₂
1,2,4-Trichlorobenzene	0% Detection Frequency, All ND RLs < TSRIASL ₁₂ in E2 and E3, 93% ND RLs < TSRIASL ₁₂ for E1
1,2-Dibromoethane (EDB)	0% Detection Frequency, All ND RLs > RIASL ₁₂
1,2-Dichloroethane	21%-50% Detection Frequency, All detects and ND RLs < RIASL ₁₂
alpha-Chlorotoluene	0% Detection Frequency, All ND RLs < RIASL ₁₂ , for E2 and E3, 93% ND RLs < RIASL ₁₂ in E1
Bromodichloromethane	0% Detection Frequency, All ND RLs < RIASL ₁₂ for E2 and E3, 93% ND RLs < RIASL ₁₂ in E1
Chloroform	93%-100% Detection Frequency, All detects and ND RLs < RIASL ₁₂
Dibromochloromethane	0% Detection Frequency, All ND RLs < RIASL ₁₂ for E2 and E3, 93% ND RLs < RIASL ₁₂ in E1
Dibromomethane	0% Detection Frequency, All ND RLs < RIASL ₁₂ for E2 and E3, 93% ND RLs < RIASL ₁₂ in E1
Hexachlorobutadiene	0% Detection Frequency, All ND RLs > RIASL ₁₂
Naphthalene	0%-14% Detection Frequency, All detects and ND RLs < RIASL ₁₂ in E2 and E3, 93% ND RLs < RIASL ₁₂ in E1

WEIGHT-OF-EVIDENCE SUMMARY

Building 827 was confirmed as a VI Path Forward Group 4A building due to its potential for VI based on sub-slab soil gas exceedances of the draft project-specific RIASL₁₂ and/or TSRIASL₁₂ for PCE and TCE. However, after further investigation and evaluation, the following evidence supports the conclusion that VI is insignificant at Building 827:

- No exceedances of draft project-specific screening levels in indoor air for any compound other than TCE and no exceedances of TCE during last three rounds of testing.
- The sub-slab soil gas data do not show any strong time dependence nor do the data show any strong seasonal effects.
- The data do not support the hypothesis that wintertime should have the highest indoor air impacts. The sub-slab soil gas concentrations are no higher in winter than during other seasons. Similarly, the highest indoor air concentrations were measured in the summer.
- As shown in the table below, the building-specific attenuation factor yields estimated indoor air concentration for the ND RL of EDB well below the screening level.

Parameters	EDB
Building-specific AF	1.2E-05
Maximum detected concentration in SSSG (827-SS-11)	<370
Estimated Indoor Air Concentration	<0.0036
Indoor Air ND RL at 827-IA-11	<0.27
Indoor Air RIASL ₁₂	0.2

Based on the CSM for Building 827, VI is an insignificant exposure pathway for current building utilization.

SUMMARY AND PATH FORWARD

Building 827 is confirmed as a VI Path Forward Group 4A building. Based on the indoor air results, the VI pathway at Building 827 is an insignificant exposure pathway and indoor air detections appear to be the result of workplace chemical use and not attributable to VI. Maximum indoor air detections were less than 0.2% of the Dow OELs for analytes that exceeded the RIASL₁₂. Further investigation activities were conducted with a mobile GC in May and July 2019 and reported in the October 2019 Summary of Investigative Findings (see Appendix C). During these activities, the weight of evidence collected throughout this investigation confirms that the elevated TCE and chloroform concentrations in Building 827 are likely due to active workplace chemical use and not attributable to VI.

Seasonal confirmation sampling is complete and upon receipt and evaluation of the fall 2019 sampling results (E8), an interim monitoring plan will be implemented. A results update and the building-specific interim monitoring plan will be provided to EGLE in an early 2020 Corrective Action meeting.

Based on the evaluation of the seasonal confirmation sampling events and the further investigation activities, the VI pathway continues to be insignificant at Building 827. Sufficient information exists to make a human exposure under control EI determination.

Area

Figure 827-1

Legend

- ⊗ 827-### Sub-slab/Indoor Air Location
- Exceeds RIASL₁₂ Only
- Exceeds TSRIASL₁₂
- Exceeds Dow OEL

Media	COC	RIASL ₁₂	TSRIASL ₁₂	OEL
Soil Gas	TCE	130	400	--
Indoor Air	TCE	4	12	26,850

TCE	Soil Gas ug/m ³	Indoor Air ug/m ³
Event 1	920	0.27
Event 2	1,900	0.26
Event 3	1,700	ND (0.09)
Event 4	1,300	1.9
Event 5	1,400	0.97
Event 6	160	ND (0.17)
Event 7	1,400	ND (0.18)

TCE	Soil Gas ug/m ³	Indoor Air ug/m ³
Event 1	86	0.19
Event 2	140	0.52
Event 3	77	ND (0.1)
Event 4	60	5
Event 5	ND (28)	0.91
Event 6	ND (41)	ND (0.18)
Event 7	42	ND (0.19)

TCE	Soil Gas ug/m ³	Indoor Air ug/m ³
Event 1	1,100	0.2
Event 2	1,500	0.44
Event 3	280	ND (0.09)
Event 4	840	7.9
Event 5	670	1.3
Event 6	920	ND (0.19)
Event 7	840	ND (0.18)

TCE	Soil Gas ug/m ³	Indoor Air ug/m ³
Event 1	2.2	0.26
Event 2	4.25	0.41
Event 3	6.8	ND (0.095)
Event 4	ND (2.15)	1.8

TCE	Soil Gas ug/m ³	Indoor Air ug/m ³
Event 1	ND (22.5)	0.21
Event 2	ND (16.5)	0.6
Event 3	ND (22)	ND (0.09)
Event 4	ND (30)	2

TCE	Soil Gas ug/m ³	Indoor Air ug/m ³
Event 1	ND (2.1)	0.19
Event 2	ND (2.1)	0.45
Event 3	ND (2.2)	ND (0.085)
Event 4	ND (2.1)	0.6

TCE	Soil Gas ug/m ³	Indoor Air ug/m ³
Event 1	110	32
Event 2	28	0.51
Event 3	22	ND (0.09)
Event 4	14	0.58
Event 5	4	0.28
Event 6	ND (4.2)	0.2
Event 7	ND (4.4)	ND (0.18)

TCE	Soil Gas ug/m ³	Indoor Air ug/m ³
Event 1	5.2	0.23
Event 2	ND (2.25)	0.43
Event 3	ND (2.15)	ND (0.09)
Event 4	ND (2.1)	0.62

TCE	Soil Gas ug/m ³	Indoor Air ug/m ³
Event 1	ND (2)	0.2
Event 2	ND (2.15)	0.46
Event 3	9.7	ND (0.095)
Event 4	ND (2.1)	0.67

TCE	Soil Gas ug/m ³	Indoor Air ug/m ³
Event 1	ND (1.95)	0.21
Event 2	ND (2.25)	0.4
Event 3	ND (2.15)	ND (0.09)
Event 4	ND (2.15)	0.57

TCE	Soil Gas ug/m ³	Indoor Air ug/m ³
Event 1	ND (2.2)	0.23
Event 2	ND (2.15)	0.41
Event 3	ND (2.15)	ND (0.09)
Event 4	ND (2.1)	0.75

TCE	Soil Gas ug/m ³	Indoor Air ug/m ³
Event 1	ND (2.25)	0.23
Event 2	ND (2.2)	0.48
Event 3	ND (2.05)	ND (0.09)
Event 4	ND (2.25)	0.59

TCE	Soil Gas ug/m ³	Indoor Air ug/m ³
Event 1	4	0.2
Event 2	ND (2.35)	0.45
Event 3	ND (2.15)	ND (0.095)
Event 4	ND (2.25)	0.54

TCE	Soil Gas ug/m ³	Indoor Air ug/m ³
Event 1	ND (4.3)	12
Event 2	ND (4.2)	1.6
Event 3	ND (2)	4
Event 4	ND (5.5)	7.4
Event 5	ND (4)	9.1
Event 6	ND (8.3)	1
Event 7	ND (4.1)	1.4

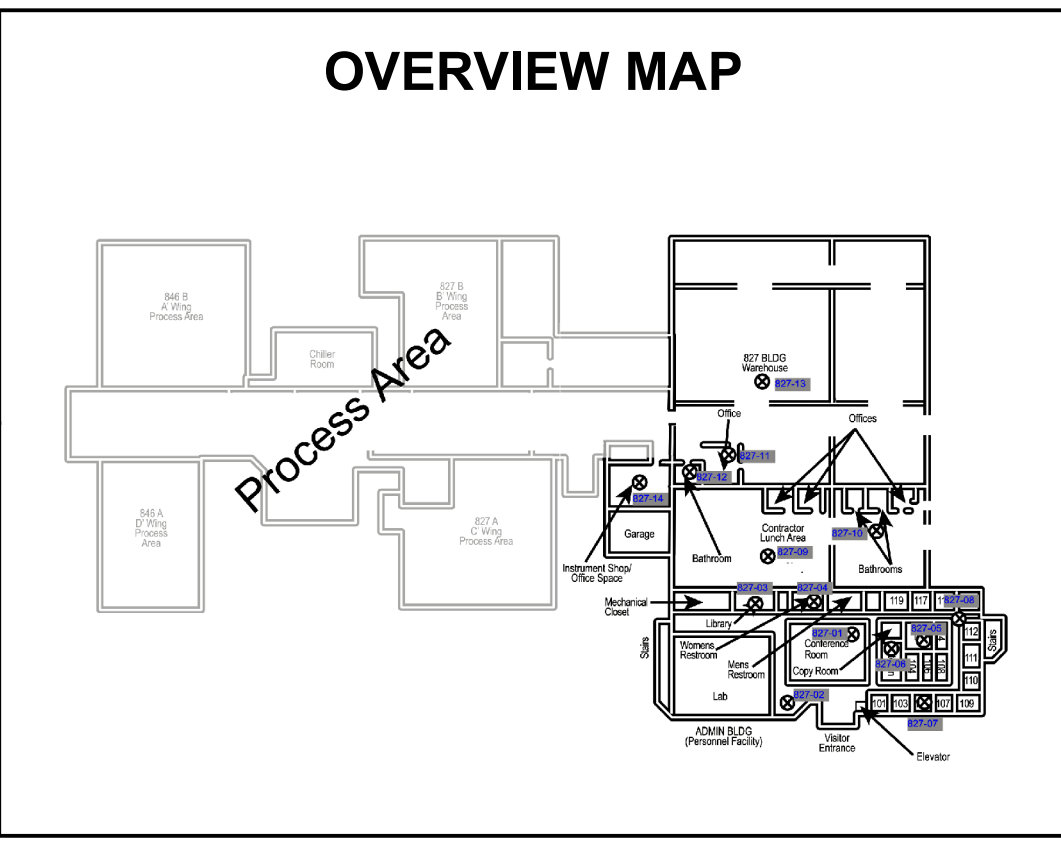
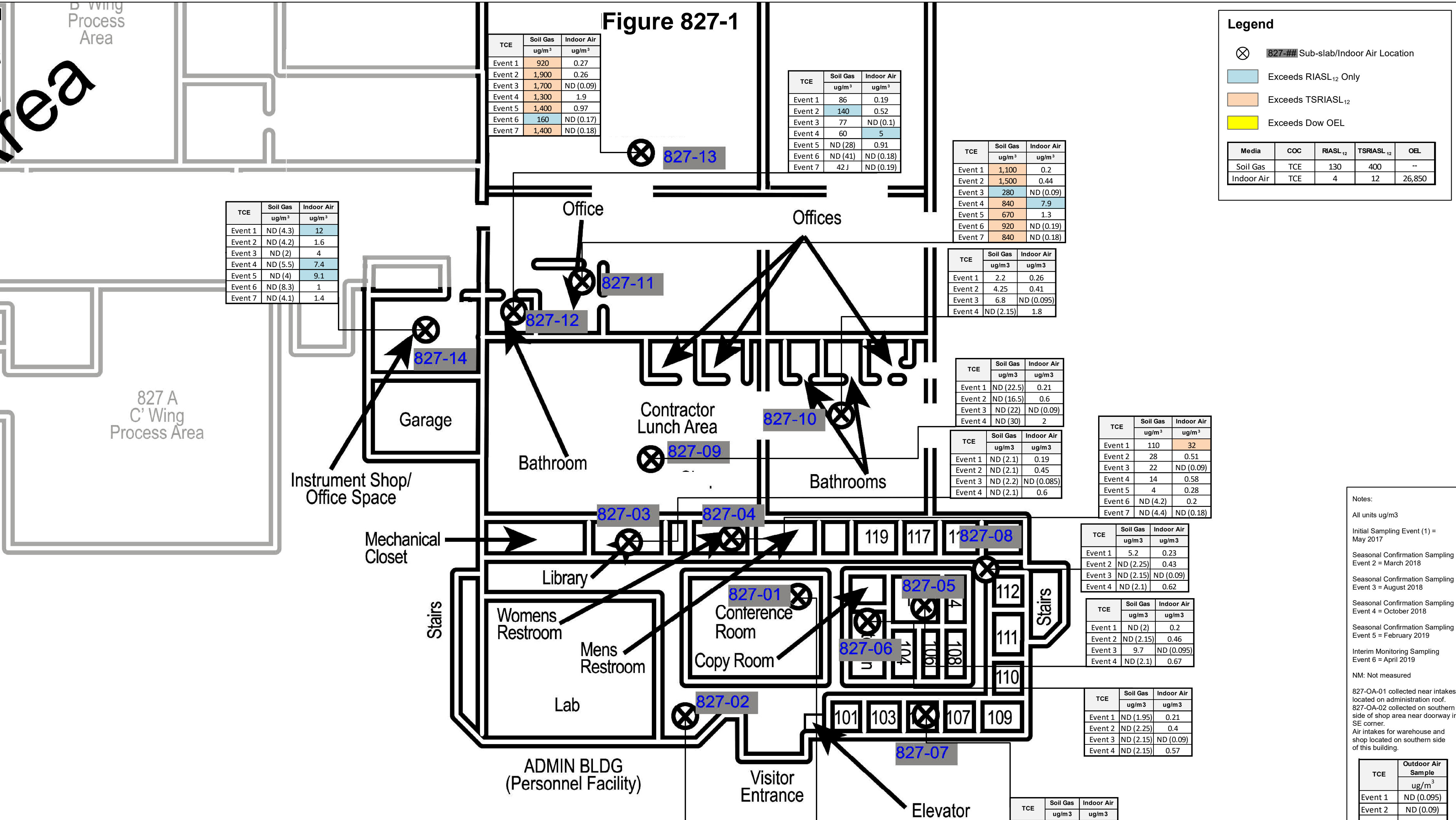

Notes:
 All units ug/m³
 Initial Sampling Event (1) = May 2017
 Seasonal Confirmation Sampling Event 2 = March 2018
 Seasonal Confirmation Sampling Event 3 = August 2018
 Seasonal Confirmation Sampling Event 4 = October 2018
 Seasonal Confirmation Sampling Event 5 = February 2019
 Interim Monitoring Sampling Event 6 = April 2019
 NM: Not measured

827-OA-01 collected near intakes located on administration roof.
 827-OA-02 collected on southern side of shop area near doorway in SE corner.
 Air intakes for warehouse and shop located on southern side of this building.

TCE	Outdoor Air Sample ug/m ³
Event 1	ND (0.095)
Event 2	ND (0.09)
Event 3	ND (0.1)
Event 4	0.4
Event 5	ND (0.08)
Event 6	ND (0.18)
Event 7	ND (0.2)

TCE	Outdoor Air Sample ug/m ³
Event 1	ND (0.09)
Event 2	ND (0.09)
Event 3	ND (0.095)
Event 4	0.33
Event 5	ND (0.085)
Event 6	ND (0.18)

Sub-slab Soil Gas and Indoor Air Results for Trichloroethene Zone 2 Phase 1 Sampling Events 1 - 7 Building 827

5.3.6 VI Seasonal Confirmation Sampling Results Evaluation for Building 948

INTRODUCTION

Building 948 is a Category 2 building in Zone 2. This building has an office, laboratory, locker rooms, process area, and a control room. It is known as Phenoxy Herbicides Building and is located within the central portion of the facility designated as Zone 2 (Figure 5.3.6-1). The initial evaluation in the 2017 CAIP concluded that based on the indoor air results, the VI pathway at Building 948 was an insignificant exposure pathway based on current use. Indoor air results were less than screening levels, with the exception of PCE, which is used in the process at Building 948. Sub-slab soil gas results for benzene, chloroform, cis-1,2-DCE, cumene, ethylbenzene, PCE, and TCE exceeded screening levels and Building 948 in VI Path Forward Building Group 4A. Group 4A is a designation for buildings that have sub-slab soil gas and indoor air AOIs exceedances; however, there is a lack of correlated sample exceedances and other lines of evidence that indicate that VI is insignificant and IA exceedances are likely due to routine workplace chemical use. Interim response actions are not necessary to address the detections of PCE in indoor air at Building 948; however, seasonal confirmation sampling was conducted.

The results of the initial sampling event (E1) were evaluated in the 2017 CAIP. Two additional seasonal events (E2 & E3) were completed and evaluated in Section 5.2.4 of the 2018 CAIP. The results of all completed seasonal events, including E4 from fall 2018, are included in this evaluation.

Building 948	
Initial Sampling Event	Completed
E1	April/May 2017 (Spring)
Seasonal Sampling Event	Completed
E2	February 2018 (Winter)
E3	August 2018 (Summer)
E4	October 2018 (Fall)

Based on the evaluation of the four seasonal confirmation sampling events, the VI pathway continues to be insignificant. Sufficient information exists to make a human exposure under control EI determination.

SUB-SLAB SOIL GAS RESULTS EVALUATION

Sub-slab soil gas samples were collected from nine locations from within the building. Indoor air samples were collected at nine locations corresponding to the soil gas sample locations, along with an outdoor air sample from the main air intake. The sampling locations are shown on Figure 5.3.6-2. Summary statistics and screening comparison results are presented for sub-slab soil gas on Table 5.3.6-A and indoor and outdoor air on Table 5.3.6-B. The analytical data is presented in Appendix A. Field sampling forms are provided in Appendix B. Table 948-1 presents the sub-slab soil gas results from seasonal confirmation sampling that exceed the draft project-specific screening levels.

Table 948-1. Summary of Sub-Slab Soil Gas Exceedances for Building 948

Analyte (Sampling Event)	Detection Frequency	Measured Range of Detects ($\mu\text{g}/\text{m}^3$)	% Detections > Screening Level	Screening Level* ($\mu\text{g}/\text{m}^3$)
Benzene (1)	44%	28 - 4,700	11 %	510
Benzene (2)	33%	11 - 1,500	11%	510
Benzene (3)	22%	4.8 - 8.3	0%	510
Benzene (4)	11%	61	0%	510
Chloroform (1)	44%	12 - 630	33%	170
Chloroform (2)	56%	18 - 620	44%	170
Chloroform (3)	56%	92 - 950	33%	170
Chloroform (4)	67%	15 - 260	33%	170

Table 948-1. Summary of Sub-Slab Soil Gas Exceedances for Building 948 (Continued)

Analyte (Sampling Event)	Detection Frequency	Measured Range of Detects ($\mu\text{g}/\text{m}^3$)	% Detections > Screening Level	Screening Level* ($\mu\text{g}/\text{m}^3$)
cis-1,2-Dichloroethene (1)	89%	24 - 5,800	44%	820
cis-1,2-Dichloroethene (2)	89%	13 - 6,500	33%	820
cis-1,2-Dichloroethene (3)	89%	44 - 37,000	44%	820
cis-1,2-Dichloroethene (4)	89%	39 - 11,000	22%	820
Cumene (1)	44%	26 - 3,100	22%	380
Cumene (2)	33%	92 - 1,600	11%	380
Cumene (3)	11%	140	0%	380
Cumene (4)	0%	ND	0%	380
Ethylbenzene (1)	56%	25 - 11,000	11%	1,600
Ethylbenzene (2)	44%	26 - 6,400	11%	1,600
Ethylbenzene (3)	67%	11 - 750	0%	1,600
Ethylbenzene (4)	33%	36 - 110	0%	1,600
Tetrachloroethene (1)	100%	380 - 230,000	89%	2,700
Tetrachloroethene (2)	100%	4,600 - 260,000	100%	2,700
Tetrachloroethene (3)	100%	1,300 - 230,000	78%	2,700
Tetrachloroethene (4)	100%	900 - 170,000	89%	2,700
Trichloroethene (1)	100%	22 - 16,000	78%	130
Trichloroethene (2)	100%	200 - 16,000	100%	130
Trichloroethene (3)	100%	33 - 13,000	78%	130
Trichloroethene (4)	100%	22 - 8,800	89%	130

*Screening level provided is the draft project-specific RIASL₁₂.

Table 948-2 summarizes the indoor air results relative to the sub-slab soil gas exceedances, since VI only potentially occurs if the analyte is present in both sub-slab soil gas and indoor air. Therefore, the table below provides the analyte detected above applicable screening levels in sub-slab soil gas as well as the corresponding indoor air sample result. The outdoor air sample result is also provided to determine if the analytes were present in indoor air due to migration from outdoor air.

Table 948-2. Vapor Intrusion Evaluation for Building 948

Analyte (Sampling Event)	Indoor Air Detection Frequency	Indoor Air Measured Range ($\mu\text{g}/\text{m}^3$)	Indoor Air Screening Level* ($\mu\text{g}/\text{m}^3$)	Outdoor Air Result ($\mu\text{g}/\text{m}^3$)
Benzene (1)	56%	0.43 - 2.4	15.4	0.6
Benzene (2)	100%	0.49 - 0.75	15.4	0.49
Benzene (3)	100%	0.28 - 0.57	15.4	0.34
Benzene (4)	100%	0.31 - 2.2	15.4	0.31
Chloroform (1)	100%	0.27 - 0.8	5.2	ND
Chloroform (2)	100%	0.28 - 0.51	5.2	0.18
Chloroform (3)	100%	0.30 - 1.3	5.2	0.20
Chloroform (4)	100%	0.17 - 0.60	5.2	ND
cis-1,2-Dichloroethene (1)	67%	0.57 - 0.88	24	ND
cis-1,2-Dichloroethene (2)	89%	0.20 - 1.4	24	ND
cis-1,2-Dichloroethene (3)	100%	0.13 - 0.25	24	ND
cis-1,2-Dichloroethene (4)	67%	0.12 - 0.59	24	ND
Cumene (1)	0%	ND	11.4	ND
Cumene (2)	0%	ND	11.4	ND
Cumene (3)	0%	ND	11.4	ND
Cumene (4)	0%	ND	11.4	ND
Ethylbenzene (1)	100%	0.44 - 1.6	48	ND
Ethylbenzene (2)	100%	0.38 - 4.1	48	ND
Ethylbenzene (3)	100%	0.20 - 1.1	48	0.18
Ethylbenzene (4)	100%	0.25 - 0.57	48	0.23

Table 948-2. Vapor Intrusion Evaluation for Building 948 (Continued)

Analyte (Sampling Event)	Indoor Air Detection Frequency	Indoor Air Measured Range ($\mu\text{g}/\text{m}^3$)	Indoor Air Screening Level* ($\mu\text{g}/\text{m}^3$)	Outdoor Air Result ($\mu\text{g}/\text{m}^3$)
Tetrachloroethene (1)	100%	21 - 330	82	5.1
Tetrachloroethene (2)	100%	4.1 - 13	82	5.4
Tetrachloroethene (3)	100%	6 - 12	82	4.9
Tetrachloroethene (4)	100%	1.3 - 7.6	82	0.24
Trichloroethene (1)	89%	0.19 - 1.1	4	ND
Trichloroethene (2)	100%	0.28 - 0.39	4	0.20
Trichloroethene (3)	67%	0.17 - 0.40	4	ND
Trichloroethene (4)	0%	ND	4	ND

*Screening level provided is the draft project-specific RIASL12.

All indoor air results for Building 948, with the exception of PCE at 6 out of 9 locations during E1, are below screening levels. All indoor air results for PCE during E2, E3 and E4 are well below the screening level. Figure 948-1 shows results for each sample location per event for PCE.

VAPOR INTRUSION CONCEPTUAL SITE MODEL

VI is an exposure pathway that involves the migration of volatilized chemicals from the subsurface to indoor air in overlying, occupied buildings. A source, migration route and a human receptor must be present for the VI pathway to be complete. The focus of this building specific investigation is to evaluate the potential VI exposure pathway for Dow employees and contractors at Building 948. The CSM is illustrated in Figure 5.3.6-3.

Building 948 is a Category 2 building located in the central portion of the facility designated as Zone 2. It is known as the Phenoxy Herbicides Building. Building 948 is two stories tall and includes process area, a control room, a laboratory, locker rooms, and office space. The building has central air conditioning and the air intake is along the front of the building. There are no bay doors. The land surrounding the building consists of asphalt.

Approximately 15 to 20 occupants work in Building 948, including office and operations staff. Operations staff are in the building 24 hours per day, seven days a week, working four six-hour shifts. The office staff work Monday through Friday, 8am to 5pm. The typical parameters for non-residential exposures are assumed to apply to workers at this building (i.e., 40 hours/week, 50 weeks/year exposure).

A building survey was performed before the initial sampling event. During the building survey, drains and other openings were screened with a PID and no soil gas entry points were identified (no detections indicated). A chemical inventory was completed during the building survey and a wide variety of chemicals were found. A chemical inventory was completed during the building survey and the chemicals found to be stored within the building, each listed in the survey, included cleaners, disinfectants, and spray paint.

Further investigation activities were conducted in July 2019 using real-time measurement devices to identify potential pathways for vapor intrusion. Findings were reported to EGLE in the October 2019 Summary of Investigative Findings (see Appendix C). The goal of the building-specific investigation for Building 948 was to identify potential sources and achieve better spatial resolution of PCE concentrations in the indoor air. As noted above, PCE is one of the chemicals used in the process at Building 948 and therefore is expected to be detected in indoor air. During these activities, potential workplace indoor air sources and various potential preferential pathways were investigated with no significant findings.

While PCE in sub-slab soil gas at Building 948 has consistently exceeded screening levels, only the initial seasonal confirmation sampling event in April/May 2017 (E1) had indoor air exceedances for PCE. The

additional three seasonal confirmation sampling events showed significantly lower concentrations of PCE in indoor air, well below the screening levels. The locations of the highest concentrations of PCE during E1 were in the corridors surrounding the laboratory and in the eastern two-thirds of the building, while the western third of the building had relatively low concentrations of PCE. The laboratory is known to work with PCE and multiple bottles of laboratory-grade PCE were found in the vent hood and a flammables cabinet in the laboratory. Therefore, it is possible that a PCE spill or large PCE experiment that occurred outside of the vent hood in the laboratory could have an impact comparable to E1 in April/May 2017 in the eastern two-thirds of the building.

An acetone laboratory release experiment was conducted and demonstrated that due to HVAC connectivity, a PCE spill or large unvented PCE experiment in the laboratory could result in PCE concentrations in indoor air similar to what was detected during E1. Overall, the weight of evidence collected throughout the investigation confirmed that the elevated indoor air PCE concentrations observed in Building 948 during the first sampling event were likely due to laboratory chemical use and were not attributable to VI.

EVALUATION OF SEASONAL CONFIRMATION SAMPLING EVENTS

Four seasonal sampling events and one interim monitoring event have been completed at Building 948. The sampling events encompass more than one year of time and include sampling during each season of the year. The results from the four seasonal confirmation sampling events were evaluated with respect to spatial variability, temporal variability, and seasonal trend analysis.

Building specific attenuation factors (α) were calculated and compared between events to evaluate temporal variability and determine the best estimate of a building-specific attenuation factor. This evaluation serves to confirm that the existing study design is appropriate, and also provides insight for the determination of the path forward for this building.

This evaluation focused on any analytes detected in the sub-slab soil gas samples that met the criterion for inclusion in one or more of the following categories:

- a) Analytes detected in sub-slab soil gas at concentrations that exceeded draft project-specific screening levels;
- b) Analytes detected in sub-slab soil gas at concentrations of 1,000 $\mu\text{g}/\text{m}^3$ or greater in one or more samples. Data for analytes detected above 1,000 $\mu\text{g}/\text{m}^3$ should provide the clearest signal and be the simplest to interpret when assessing data trends. The same data trends observed for these analytes are expected to apply to other similar analytes present at lower concentrations; and
- c) PCE and TCE. These two analytes are of particular interest for many VI evaluations at industrial sites.

For this building, the analytes detected in the sub-slab soil gas at concentrations above the draft project-specific screening levels were the following seven analytes: benzene, chloroform, cis-1,2-DCE, cumene, ethylbenzene, PCE, and TCE. Four other analytes of potential interest were detected at concentrations $\geq 1,000 \mu\text{g}/\text{m}^3$ in sub-slab soil gas: 1,1,1-TCA, 4-ethyltoluene, propylbenzene and toluene; however, these analytes are not included in this evaluation due to their low detection frequency. Sample results for the seven analytes included in this evaluation are provided in the data tables below:

Summary of Results for Benzene

Sample Type	Sample ID	Measured Concentration ($\mu\text{g}/\text{m}^3$)			
		Apr./May 2017	Feb. 2018	Aug. 2018	Oct. 2018
		E1	E2	E3	E4
Outdoor Air	948-OA-01	0.60	0.49	0.34	0.31
Indoor Air	948-IA-01	0.67	0.64	0.39	0.34
	948-IA-02	0.48	0.75	0.35	0.37
	948-IA-03	0.43	0.64	0.32	2.2
	948-IA-04	<0.65	0.49	0.28	0.41
	948-IA-05	<0.66	0.52	0.57	0.35
	948-IA-06	1.1	0.54	0.32	0.41
	948-IA-07	<0.52	0.55	0.33	0.34
	948-IA-08	<0.39	0.58	0.28	0.36
	948-IA-09	2.4	0.52	0.31	0.31
Sub-Slab Soil Gas	948-SS-01	32	11	4.8	<2.6
	948-SS-02	28	<17	8.3	<10
	948-SS-03	30	15	<16	<9.8
	948-SS-04	<51	<25	<24	<24
	948-SS-05	<52	<49	<130	<48
	948-SS-06	<26	<34	<26	<54
	948-SS-07	4,700	1,500	<48	61
	948-SS-08	<250	<100	<120	<52
	948-SS-09	<17	<16	<24	<27

Screening levels for indoor air are $15.4 \mu\text{g}/\text{m}^3$ (RIASL₁₂) and $54 \mu\text{g}/\text{m}^3$ (TSRIASL₁₂)
Screening levels for soil-gas are $510 \mu\text{g}/\text{m}^3$ (RIASL₁₂) and $1,800 \mu\text{g}/\text{m}^3$ (TSRIASL₁₂)

Summary of Results for Chloroform

Sample Type	Sample ID	Measured Concentration ($\mu\text{g}/\text{m}^3$)			
		Apr./May 2017	Feb. 2018	Aug. 2018	Oct. 2018
		E1	E2	E3	E4
Outdoor Air	948-OA-01	<0.25	0.18	0.20	<0.17
Indoor Air	948-IA-01	0.44	0.43	1	0.60
	948-IA-02	0.27	0.32	0.93	0.28
	948-IA-03	0.45	0.51	1.3	0.56
	948-IA-04	0.44	0.35	0.36	0.28
	948-IA-05	0.56	0.41	0.33	0.25
	948-IA-06	0.80	0.49	0.47	0.21
	948-IA-07	0.48	0.28	0.31	0.60
	948-IA-08	0.44	0.30	0.30	0.17
	948-IA-09	0.54	0.48	0.54	0.20
Sub-Slab Soil Gas	948-SS-01	<4	<10	<3.8	<4
	948-SS-02	<39	<26	<7.7	16
	948-SS-03	12	18	<25	15
	948-SS-04	310	330	120	230
	948-SS-05	190	520	950	260
	948-SS-06	<39	<52	92	<83
	948-SS-07	630	620	270	180
	948-SS-08	<380	270	300	170
	948-SS-09	<26	<24	<38	<41

Screening levels for indoor air are $5.2 \mu\text{g}/\text{m}^3$ (RIASL₁₂) and $52 \mu\text{g}/\text{m}^3$ (TSRIASL₁₂)
Screening levels for soil-gas are $170 \mu\text{g}/\text{m}^3$ (RIASL₁₂) and $1,700 \mu\text{g}/\text{m}^3$ (TSRIASL₁₂)

	RIASL12 Exceedance
	TSRIASL12 Exceedance

Summary of Results for cis-1,2-Dichloroethene

Sample Type	Sample ID	Measured Concentration ($\mu\text{g}/\text{m}^3$)			
		Apr./May 2017	Feb. 2018	Aug. 2018	Oct. 2018
		E1	E2	E3	E4
Outdoor Air	948-OA-01	<0.20	<0.13	<0.13	<0.14
Indoor Air	948-IA-01	<0.19	1.4	0.14	<0.13
	948-IA-02	<0.14	<0.13	0.13	<0.13
	948-IA-03	<0.12	0.34	0.14	<0.13
	948-IA-04	0.58	0.20	0.14	0.33
	948-IA-05	0.71	0.23	0.14	0.26
	948-IA-06	0.57	0.20	0.16	0.12
	948-IA-07	0.76	0.22	0.19	0.17
	948-IA-08	0.88	0.20	0.25	0.12
	948-IA-09	0.74	0.31	0.15	0.59
Sub-Slab Soil Gas	948-SS-01	<3.3	13	<3.1	<3.2
	948-SS-02	1,800	82	250	240
	948-SS-03	24	56	110	39
	948-SS-04	840	520	130	200
	948-SS-05	400	830	1,400	330
	948-SS-06	1,100	<42	37,000	11,000
	948-SS-07	690	3,200	1500	460
	948-SS-08	5,800	6,500	5,200	2,800
	948-SS-09	310	88	44	52

Screening levels for indoor air are $24 \mu\text{g}/\text{m}^3$ (RIASL₁₂) and $72 \mu\text{g}/\text{m}^3$ (TSRIASL₁₂)
Screening levels for soil-gas are $820 \mu\text{g}/\text{m}^3$ (RIASL₁₂) and $,2500 \mu\text{g}/\text{m}^3$ (TSRIASL₁₂)

Summary of Results for Cumene

Sample Type	Sample ID	Measured Concentration ($\mu\text{g}/\text{m}^3$)			
		Apr./May 2017	Feb. 2018	Aug. 2018	Oct. 2018
		E1	E2	E3	E4
Outdoor Air	948-OA-01	<1.3	<0.79	<0.83	<0.86
Indoor Air	948-IA-01	<1.2	<0.88	<0.81	<0.79
	948-IA-02	<0.88	<0.80	<0.77	<0.82
	948-IA-03	<0.76	<0.86	<0.80	<0.80
	948-IA-04	<2	<0.79	<0.82	<0.79
	948-IA-05	<2	<0.88	<0.78	<0.75
	948-IA-06	<2	<0.86	<0.82	<0.77
	948-IA-07	<1.6	<0.86	<0.81	<0.77
	948-IA-08	<1.2	<0.84	<0.81	<0.84
	948-IA-09	<1.6	<0.86	<0.80	<0.81
Sub-Slab Soil Gas	948-SS-01	<4	<10	<3.8	<4
	948-SS-02	<40	<26	<7.7	<16
	948-SS-03	<7.5	<12	<25	<15
	948-SS-04	220	210	<38	<36
	948-SS-05	<80	<75	<200	<75
	948-SS-06	<39	92	<40	<84
	948-SS-07	1,800	1,600	140	<38
	948-SS-08	3,100	<160	<190	<81
	948-SS-09	26	<24	<38	<42

Screening levels for indoor air are $11.4 \mu\text{g}/\text{m}^3$ (RIASL₁₂)
Screening levels for soil-gas are $380 \mu\text{g}/\text{m}^3$ (RIASL₁₂)

	RIASL12 Exceedance
	TSRIASL12 Exceedance

Summary of Results for Ethylbenzene

Sample Type	Sample ID	Measured Concentration ($\mu\text{g}/\text{m}^3$)			
		Apr./May 2017	Feb. 2018	Aug. 2018	Oct. 2018
		E1	E2	E3	E4
Outdoor Air	948-OA-01	<0.22	<0.14	0.18	0.23
Indoor Air	948-IA-01	0.63	0.38	1	0.28
	948-IA-02	0.57	0.38	1	0.25
	948-IA-03	0.60	4.1	1.1	0.34
	948-IA-04	0.44	0.83	0.20	0.57
	948-IA-05	0.53	1.2	0.43	0.52
	948-IA-06	1.3	0.88	0.20	0.45
	948-IA-07	0.58	0.68	0.36	0.51
	948-IA-08	0.50	0.70	0.41	0.57
	948-IA-09	1.6	1.5	0.23	0.51
Sub-Slab Soil Gas	948-SS-01	25	290	11	36
	948-SS-02	<35	<23	14	<14
	948-SS-03	26	26	34	<13
	948-SS-04	180	450	180	110
	948-SS-05	<71	<66	<180	<66
	948-SS-06	<35	<46	69	<74
	948-SS-07	11,000	6,400	750	110
	948-SS-08	1400	<140	<170	<71
	948-SS-09	<23	<22	<33	<37

Screening levels for indoor air are $48 \mu\text{g}/\text{m}^3$ (RIASL₁₂) and $480 \mu\text{g}/\text{m}^3$ (TSRIASL₁₂)
Screening levels for soil-gas are $1,600 \mu\text{g}/\text{m}^3$ (RIASL₁₂) and $16,000 \mu\text{g}/\text{m}^3$ (TSRIASL₁₂)

Summary of Results for Tetrachloroethene (PCE)

Sample Type	Sample ID	Measured Concentration ($\mu\text{g}/\text{m}^3$)			
		Apr./May 2017	Feb. 2018	Aug. 2018	Oct. 2018
		E1	E2	E3	E4
Outdoor Air	948-OA-01	5.1	5.4	4.9	0.24
Indoor Air	948-IA-01	24	4.1	6.5	1.4
	948-IA-02	21	6	6.4	1.3
	948-IA-03	36	10	6.6	1.6
	948-IA-04	330	9.7	6	2.6
	948-IA-05	330	12	8.4	2.6
	948-IA-06	310	12	6.2	1.3
	948-IA-07	310	11	9.2	7.6
	948-IA-08	250	11	12	4.4
	948-IA-09	310	13	6.5	3.4
Sub-Slab Soil Gas	948-SS-01	380	4,600	1300	900
	948-SS-02	19,000	12,000	1900	4,900
	948-SS-03	3,500	6,300	6,000	5,100
	948-SS-04	55,000	64,000	27,000	54,000
	948-SS-05	75,000	130,000	220,000	86,000
	948-SS-06	19,000	21,000	20,000	18,000
	948-SS-07	230,000	220,000	100,000	47,000
	948-SS-08	220,000	260,000	230,000	170,000
	948-SS-09	11,000	11,000	16,000	14,000

Screening level for indoor air is $82 \mu\text{g}/\text{m}^3$ (RIASL₁₂ and TSRIASL₁₂)
Screening level for soil-gas is $2,700 \mu\text{g}/\text{m}^3$ (RIASL₁₂ and TSRIASL₁₂)

	RIASL12 Exceedance
	TSRIASL12 Exceedance

Summary of Results for Trichloroethene (TCE)

Sample Type	Sample ID	Measured Concentration ($\mu\text{g}/\text{m}^3$)			
		Apr./May 2017	Feb. 2018	Aug. 2018	Oct. 2018
		E1	E2	E3	E4
Outdoor Air	948-OA-01	<0.28	0.20	<0.18	<0.19
Indoor Air	948-IA-01	<0.25	0.28	<0.18	<0.17
	948-IA-02	0.19	0.28	0.17	<0.18
	948-IA-03	0.21	0.35	0.26	<0.18
	948-IA-04	1.1	0.29	<0.18	<0.17
	948-IA-05	1.1	0.33	0.18	<0.16
	948-IA-06	1.1	0.32	0.18	<0.17
	948-IA-07	1	0.35	0.23	<0.17
	948-IA-08	0.88	0.34	0.40	<0.18
	948-IA-09	1.1	0.39	<0.18	<0.18
Sub-Slab Soil Gas	948-SS-01	22	200	33	22
	948-SS-02	870	330	91	270
	948-SS-03	130	350	350	250
	948-SS-04	2600	3000	1200	2200
	948-SS-05	2500	4700	7600	2500
	948-SS-06	460	410	580	420
	948-SS-07	16000	14000	6200	3200
	948-SS-08	15000	16000	13000	8800
	948-SS-09	270	300	370	390

Screening levels for indoor air are $4 \mu\text{g}/\text{m}^3$ (RIASL₁₂) and $12 \mu\text{g}/\text{m}^3$ (TSRIASL₁₂)
Screening levels for soil-gas are $130 \mu\text{g}/\text{m}^3$ (RIASL₁₂) and $400 \mu\text{g}/\text{m}^3$ (TSRIASL₁₂)

	RIASL12 Exceedance
	TSRIASL12 Exceedance

EVALUATION OF VI DATA TRENDS

Data trends for Building 948 are discussed below for both sub-slab soil gas and indoor air. When data exhibit a narrow range of variability, it is typical practice to express the range as a percentage. When data exhibit a large range of variability, however, it is more useful to express the range in orders of magnitude (i.e., factors of 10). This can be expressed mathematically as the log of the ratio of maximum/minimum values. If the values differ by a factor of 10, the log of the ratio is 1, if the values differ by a factor of 100, the log of the ratio is 2, and so on.

The variability across all locations over all sampling events is the total variability. This encompasses different types of variability, including spatial variability (i.e., how do the results vary from location to location), temporal variability (i.e., how do the results at a given location vary over time), and measurement variability. Measurement variability can be determined by evaluating results of duplicate or collocated samples and includes both sampling variability and analytical variability. The comparison of two data values is typically expressed as a RPD. The comparison of three or more data values is typically expressed as the %CV, which is the standard deviation divided by the mean.

Sub-Slab Soil Gas Data Trends

Spatial Variability of Sub-Slab Soil Gas – The soil gas exhibits less than three orders of magnitude of spatial variability. For example, sub-slab soil gas detections of TCE vary from 22 to 16,000 $\mu\text{g}/\text{m}^3$ (log of max./min. = 2.9) across the nine locations for E1. During that same sampling event, the range for PCE was 380 to 230,000 $\mu\text{g}/\text{m}^3$ (log of max./min. = 2.8) and the range for ethylbenzene was 25 to 11,000 $\mu\text{g}/\text{m}^3$ (log of max./min. = 2.6).

Temporal Variability of Soil Gas – The soil gas exhibits less than two orders of magnitude of temporal variability. For example, sub-slab soil gas concentrations of PCE vary from 380 to 4,600 $\mu\text{g}/\text{m}^3$ at location 948-SS-01 (log max/min = 1.1) across all four sampling events. At that same location, the range for TCE

was 22 to 200 $\mu\text{g}/\text{m}^3$ (log max/min = 1.0) and the range for ethylbenzene was 11 to 290 $\mu\text{g}/\text{m}^3$ (log max/min = 1.4). The variability for PCE, TCE and ethylbenzene at other locations was less.

Seasonal Confirmation Sampling Trend Analysis – No formal statistical tests were performed but the sub-slab soil gas data at locations with the highest concentrations are relatively consistent over the course of the four sampling events. This is illustrated in the graph below, which shows results for several locations with relatively high concentrations for the analytes detected at the highest concentrations. Note that the y-axis is a log scale.

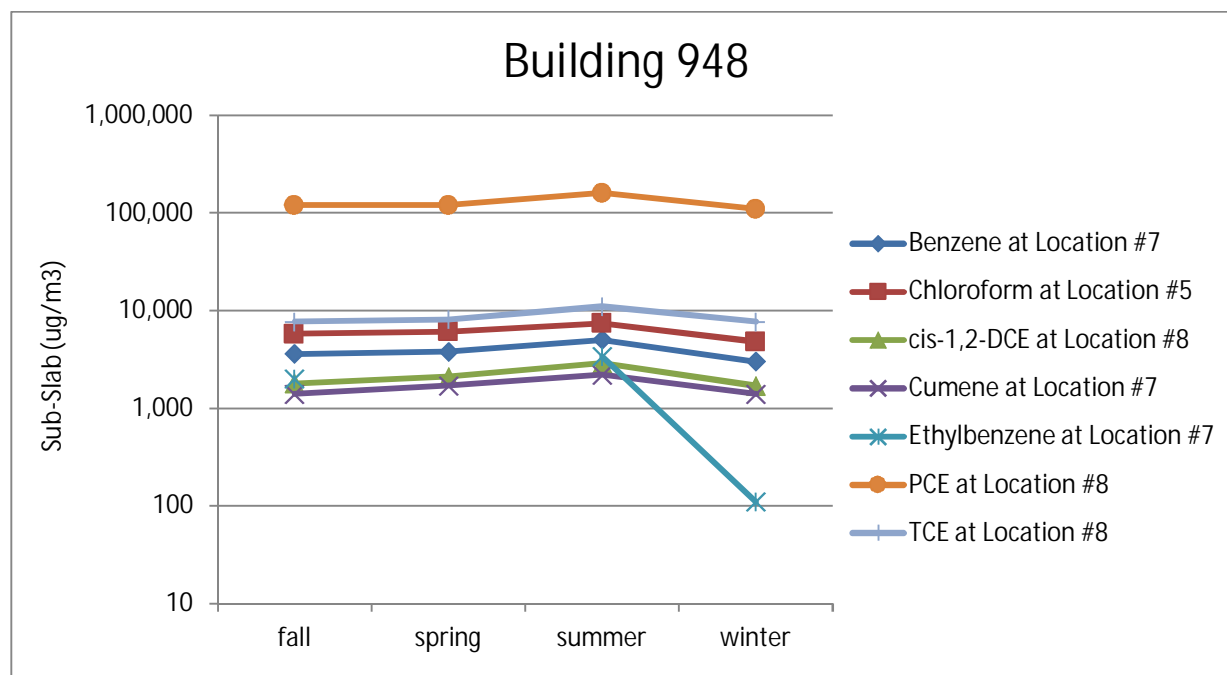

The data set was examined to see what the potential consequences would have been had only a single sampling event been performed. For benzene, cumene, ethylbenzene, PCE, and TCE, the highest sub-slab soil gas concentrations were collected during the E1 and E2 (spring and winter, respectively) and the lowest concentrations occurred during the fall (E4). Overall, the minimum and maximum values appear to be consistent between sampling events.

For benzene, ethylbenzene, and PCE, the highest concentrations were detected during E1. For TCE, a concentration of 220,000 $\mu\text{g}/\text{m}^3$ was measured during E1 and the highest concentration (260,000 $\mu\text{g}/\text{m}^3$) was measured during E2. If only E1 had been performed, a negative bias of 18% would have been introduced (i.e., the E2 result was 18% higher than the E1 result). For chloroform, the result measured in E1 was 190 $\mu\text{g}/\text{m}^3$, and the highest concentration (950 $\mu\text{g}/\text{m}^3$) was measured during E3. If only E1 had been performed, a negative bias of a factor of 5 would have been introduced. Therefore, implementing four seasonal confirmation sampling events provided only limited insight regarding maximum concentration levels, but the larger data set served to increase the confidence in the findings including demonstrating the consistency of the maximum reported results.

Indoor Air Data Trends

Spatial Variability of Indoor Air – The indoor air exhibits about one order of magnitude of spatial variability. For example, PCE was detected in all nine indoor air samples and varied from 21 to 330 $\mu\text{g}/\text{m}^3$ during E1 (log max./min. = 1.2). During E1, TCE was detected in all nine indoor air samples and varied from 0.29 to 1.1 $\mu\text{g}/\text{m}^3$ (log max./min. = 0.76).

Temporal Variability of Indoor Air – The indoor air exhibits less than two and a half orders of magnitude of temporal variability. The detected values for PCE exhibit the most temporal variability. For example, PCE values ranged from 1.3 to 310 $\mu\text{g}/\text{m}^3$ at location 948-IA-06 (log max./min. = 2.4) and from 2.6 to 330 $\mu\text{g}/\text{m}^3$ at location 948-IA-04 and 948-IA-05 (log max./min. = 2.1). The maximum variability for TCE was at sample locations 948-IA-05 and 948-IA-06, which had values ranging from 0.18 to 1.1 $\mu\text{g}/\text{m}^3$ (log max./min. = 0.79).

Additional Analyses

Comparison of Sub-Slab Soil Gas and Indoor Air Data Sets – As expected, the sub-slab soil gas data exhibit greater spatial variability than the indoor air data set. Also as expected, indoor air has greater temporal variability than the sub-slab soil gas data set.

Seasonal Effects – The data do not support the hypothesis that wintertime will have higher indoor air impacts. The highest sub-slab soil gas concentrations for most analytes were measured in the spring (E1) and the highest indoor air concentrations were also measured in the spring (E1). The data vary but do not support the hypothesis that wintertime should have the highest indoor air impacts.

Comparison of Attenuation Factors by Event – Attenuation factors were calculated for CFC-12 based on maximum values since CFC-12 had 100% detection frequency in both media. However, detections in outdoor air were very similar to detected indoor air concentrations. Therefore, the indoor air maximum concentration was corrected for contribution of outdoor air to indoor air (e.g., outdoor air detected concentration was subtracted from indoor air concentration). The calculated event-specific attenuation factors are shown in Tables 948-3.

Table 948-3. Comparison of Building-Specific Attenuation Factors for CFC-12 by Event

	E1 (Spring)	E2 (Winter)	E3 (Summer)	E4 (Fall)
Maximum Values				
CFC-12 in Sub-Slab Soil Gas ($\mu\text{g}/\text{m}^3$)	690	110	250	480
CFC-12 in Outdoor Air ($\mu\text{g}/\text{m}^3$)	2.5	2.5	2.4	2.0
CFC-12 in Indoor Air ($\mu\text{g}/\text{m}^3$)	2.6	2.6	2.4	2.5
CFC-12 in Indoor Air ($\mu\text{g}/\text{m}^3$) Corrected for Outdoor Air Contribution	0.1	0.1	0	0.5
Attenuation Factor	1.5E-04	9.1E-04	NC	1.0E-03

NC - Not calculated due to elevated detection limits for indoor air.

These serve as the best estimates of attenuation at this building. The results can vary from day to day due to differences in rates of vapor intrusion and rates of building ventilation. Overall, the most conservative estimate of a building-specific attenuation factor for Building 948 is 1.0E-03 based on CFC-12 during E4.

Temporal Variability in Attenuation Factor – As shown in Table 948-3, there is one order of magnitude in temporal variability in the calculated attenuation factors observed in the data set, with E4 having the least attenuation and E1 have the greatest attenuation.

NON-DETECT EVALUATION

If a sub-slab soil gas analyte has ND RL exceedances, but all results and ND RLs in indoor air are below the screening levels, no further evaluation is warranted. If an analyte was identified as an AOI in sub-slab soil gas (detected results > screening level), it is excluded from the ND evaluation. Also, if an ND analyte has an 0% detection frequency for all sampling events and all ND RLs met the screening level during at least one event, no further ND evaluation is warranted. Of the 15 analytes listed below, only 5 (EDB, 1,2,4-TCB, bromomethane, dibromomethane and HCBd) require further evaluation. Table 948-4 lists the

10 analytes that require no further evaluation regarding sub-slab soil gas ND RL exceedances. Table 948-5 provides a breakdown of the ND RLs for EDB, 1,2,4-TCB, bromomethane, dibromomethane, and HCBD.

Table 948-4. Sub-Slab Soil Gas Analytes with RLs that Exceed Screening Levels Requiring No ND

Analyte	Number of Samples	Detection Rate	Percent of Sub-Slab Soil Gas Detection Limits Exceeding Screening Levels	Status in IA
			(Range from E1-E4)	
1,1,2,2-Tetrachloroethane	9	0%	0%	All IA RLs met Screening Levels
1,1,2-Trichloroethane	9	0%	0%	
1,2-Dichloroethane	9	0%	0%	
1,3-Dichlorobenzene	9	0%	0%	
1,4-Dioxane	9	0%	0%	
alpha-Chlorotoluene	9	0%	0%	
Bromodichloromethane	9	0%	0%	
Chloroform	9	0%	0%- 44%	
Dibromochloromethane	9	0%	0%	
Naphthalene	9	0%	0%	

Table 948-5. ND Evaluation for SSSG Analytes with RLs that Exceed Screening Levels

Analyte	Number of Samples	Detection Rate	Sampling Event	Percent Exceed (Non-detect RL) - MDEQ Project-Specific	# Samples RL met Screening Level	Status in IA
1,2,4-Trichlorobenzene	9	0%	E1	78%	2	Some IA RLs > Screening Levels in 3 of 4 events: E1 (89% > SLs); E2 (78% > SLs); E3 (0% > SLs); E4 (11% > SLs).
			E2	78%	2	
			E3	78%	2	
			E4	67%	3	
1,2-Dibromoethane (EDB)	9	0	E1	89%	1	All IA RLs > Screening Levels
			E2	100%	0	
			E3	89%	1	
			E4	89%	1	
Bromomethane	9	0	E1	22%	7	IA RLs > Screening Levels in 1 of 4 events: E1 (0% > SLs); E2 (0% > SLs); E3 (89% > SLs); E4 (0% > SLs).
			E2	0%	9	
			E3	0%	9	
			E4	0%	9	
Dibromomethane	9	0	E1	44%	5	IA RLs > Screening Levels in 1 of 4 events: E1 (33% > SLs); E2 (0% > SLs); E3 (0% > SLs); E4 (0% > SLs).
			E2	33%	6	
			E3	33%	6	
			E4	33%	6	
Hexachlorobutadiene (HCBD)	9	0	E1	78%	2	All IA RLs > Screening Levels
			E2	78%	2	
			E3	78%	2	
			E4	67%	3	

WEIGHT-OF-EVIDENCE SUMMARY

Building 948 was confirmed as a VI Path Forward Group 4A building due to its potential for VI based on sub-slab soil gas exceedances of the draft project-specific RIASL₁₂ and/or TSRIASL₁₂ for benzene, chloroform, cis-1,2-DCE, cumene, ethylbenzene, PCE, and TCE. However, after further investigation and evaluation, the following evidence supports the conclusion that VI is insignificant at Building 948:

- No exceedances of draft project-specific screening levels in indoor air, with the only exception being PCE during E1. PCE is one of the chemicals used in the process as well as in the laboratory in Building 948 and the maximum detected results of PCE in indoor air are less than 1% of the Dow OEL.
- The data do not support the hypothesis that wintertime should have the highest indoor air impacts. The highest sub-slab soil gas concentrations were measured in the spring. Similarly, the highest indoor air concentrations were also measured in the spring.
- The indoor air data show relatively little spatial variability, despite the greater spatial variability in the sub-slab soil gas values. This evaluation confirms that the sub-slab soil gas and indoor air concentrations were relatively constant from season to season.
- As shown in the table below, the building-specific attenuation factor yields estimated indoor air concentrations for 1,2,4-TCB, bromomethane, dibromomethane, and HCBd below the RIASL₁₂. For EDB, the maximum ND RL occurred at location 948-SS-08 during E1 and lower RLs were achieved during all other events. If the ND RL from E4 is used (130 ug/m³) the estimated indoor air concentration (0.13 ug/m³) is below the screening level.

Parameters	1,2,4-TCB	EDB	Bromomethane	Dibromomethane	HCBd
Building-specific AF	1.0E-03	1.0E-03	1.0E-03	1.0E-03	1.0E-03
Maximum reporting limit in SSSG	<2,300	<600	<1,200	<2,200	<3,300
Estimated Indoor Air Concentration	2.3	0.6	1.2	2.2	3.3
Indoor Air ND RL	<15	<0.63	<32	<15	<22
Indoor Air RIASL ₁₂	6.2	0.2	30	12.2	5.4

Based on the CSM for Building 948, VI is an insignificant exposure pathway for current building utilization.

PATH FORWARD

Building 948 is confirmed as a VI Path Forward Group 4A building. Further investigation activities were conducted with a mobile GC in July 2019 and the weight of evidence collected throughout the investigation confirms that the elevated indoor air PCE concentrations observed in Building 948 during E1 were likely due to laboratory chemical use and were not attributable to VI.

Based on the evaluation of the four seasonal confirmation sampling events and the further investigation activities, the VI pathway continues to be insignificant for Building 948 and the sub-slab soil gas results have demonstrated relatively stable concentrations and no evidence of increasing over time. Sufficient information exists to make a human exposure under control EI determination. However, while currently there is no evidence of potential VI, for future use, LTM is warranted and the implementation of the building-specific Interim Monitoring Plan began in August 2019.

Building-specific Interim Monitoring Plan

Dow presented an interim monitoring plan for Building 948 during the February 2019 Corrective Action status meeting. Interim monitoring will be performed semi-annually and monitoring began in August 2019. Dow will implement the interim monitoring plan at Building 948 until a revised program or more permanent corrective action plan is developed for the site.

Indoor air is monitored at location 948-IA-07 and 948-IA-08. These locations were selected for continued monitoring since it demonstrated the highest sub-slab soil gas results. Monitoring will be performed for benzene, chloroform, cis-1,2-DCE, cumene, ethylbenzene, PCE, and TCE. The indoor air result are shown below:

Indoor Air Analyte	Result Value (µg/m ³)	Reporting Limit (µg/m ³)	EGLE Project-Specific RIASL ₁₂ (µg/m ³)	NONRES TSRIASL ₁₂ (µg/m ³)	Dow IH OEL (8hr Time Weighted Average) (µg/m ³)
<i>Sample 948-IA-07</i>					
Benzene	0.4	0.26	15.4	54	1,595
Chloroform	0.37	0.16	5.2	52	9,760
cis-1,2-Dichloroethene	ND	0.13	24	72	794,000
Cumene	ND	0.79	11.4	NA	246,000
Ethyl Benzene	0.95	0.14	48	480	86,800
Tetrachloroethene	0.63	0.22	82	82	67,800
Trichloroethene	ND	0.17	4	12	26,850
<i>Sample 948-IA-08</i>					
Benzene	0.26	0.26	15.4	54	1,595
Chloroform	0.36	0.16	5.2	52	9,760
cis-1,2-Dichloroethene	ND	0.13	24	72	794,000
Cumene	ND	0.81	11.4	NA	246,000
Ethyl Benzene	1.1	0.14	48	480	86,800
Tetrachloroethene	1.2	0.22	82	82	67,800
Trichloroethene	ND	0.18	4	12	26,850

As shown on the table above, all indoor air result from the Summer 2019 IM event had detected results below the RIASL₁₂ or were ND with RLs below the indoor air RIASL₁₂. The analytical data is presented in Appendix A. Field sampling forms are provided in Appendix B. The next IM event is scheduled for Winter 2019/2020. Semi-annual interim monitoring will continue in the summer and winter of 2020. For future IM events, an outdoor air sample will also be collected at the time of each monitoring event.

Figure 948-1

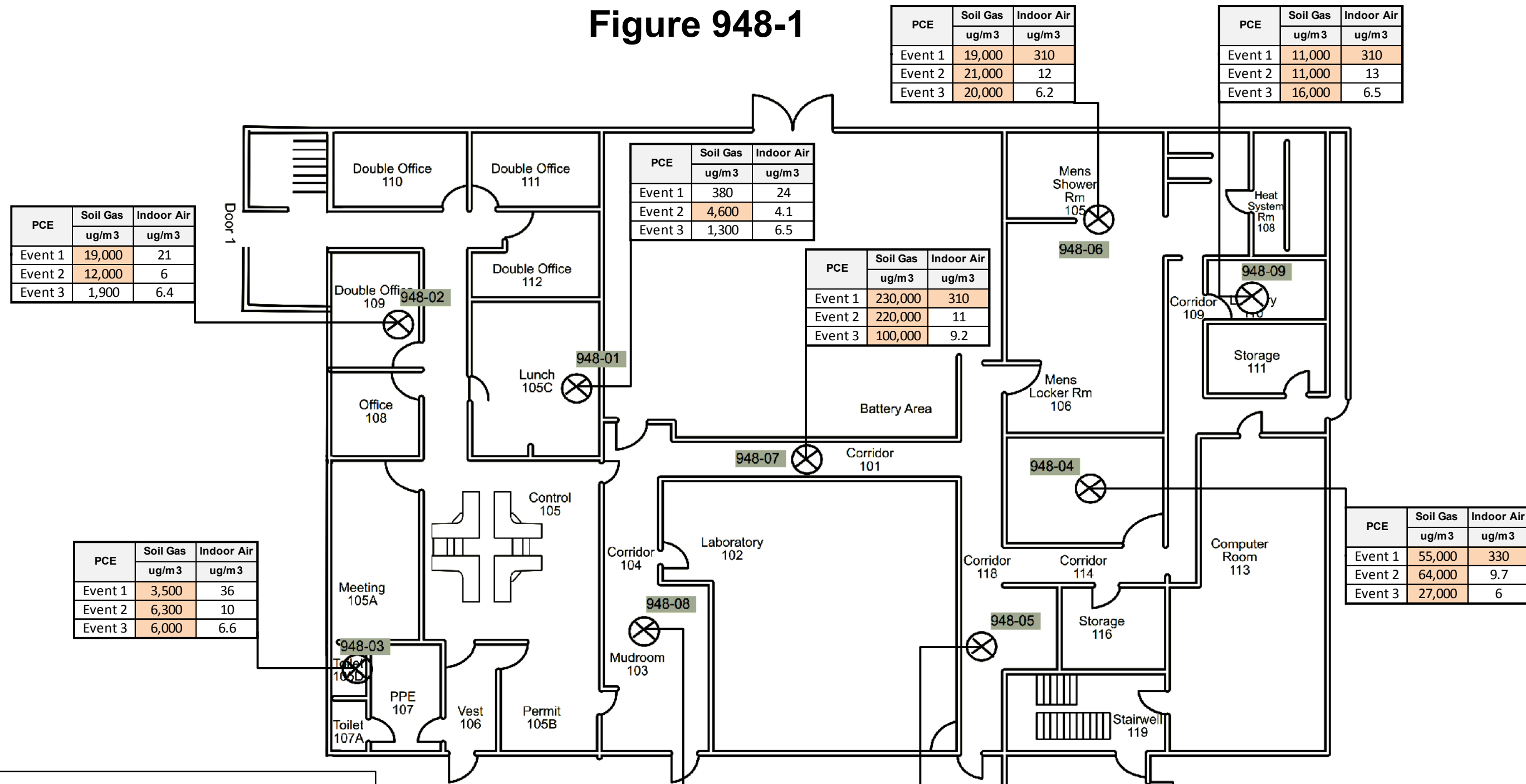

PCE	Soil Gas ug/m3	Indoor Air ug/m3
Event 1	19,000	21
Event 2	12,000	6
Event 3	1,900	6.4

PCE	Soil Gas ug/m3	Indoor Air ug/m3
Event 1	3,500	36
Event 2	6,300	10
Event 3	6,000	6.6

PCE	Soil Gas ug/m3	Indoor Air ug/m3
Event 1	220,000	250
Event 2	260,000	11
Event 3	230,000	12

PCE	Soil Gas ug/m3	Indoor Air ug/m3
Event 1	75,000	330
Event 2	130,000	12
Event 3	220,000	8.4

PCE	Soil Gas ug/m3	Indoor Air ug/m3
Event 1	19,000	310
Event 2	21,000	12
Event 3	20,000	6.2

PCE	Soil Gas ug/m3	Indoor Air ug/m3
Event 1	380	24
Event 2	4,600	4.1
Event 3	1,300	6.5

PCE	Soil Gas ug/m3	Indoor Air ug/m3
Event 1	230,000	310
Event 2	220,000	11
Event 3	100,000	9.2

PCE	Soil Gas ug/m3	Indoor Air ug/m3
Event 1	11,000	310
Event 2	11,000	13
Event 3	16,000	6.5

PCE	Soil Gas ug/m3	Indoor Air ug/m3
Event 1	55,000	330
Event 2	64,000	9.7
Event 3	27,000	6

Legend

⊗ 948-## Sub-slab/Indoor Air Location

Exceeds RIASL₁₂ Only

Exceeds TSRIASL₁₂

Exceeds Dow OEL

Media	COC	RIASL ₁₂	TSRIASL ₁₂	OEL
Soil Gas	PCE	2,700	2,700	--
Indoor Air	PCE	82	82	67,800

Notes:

All units ug/m3

Initial Sampling Event (1) = October 2017

Seasonal Confirmation Sampling Event 2 = March 2018

Seasonal Confirmation Sampling Event 3 = August 2018

Outdoor air location collected on W side of building near Door 6. Note another intake located on roof to SE of wash bay area, points NE.

PCE	Outdoor Air Sample ug/m3
Event 1	5.1
Event 2	5.4
Event 3	4.9

Sub-slab Soil Gas and Indoor Air Results for Tetrachloroethene Zone 2 Phase 1 Sampling Events 1 - 3 Building 948

Figure 948-2

PCE	Soil Gas ug/m3	Indoor Air ug/m3
Event 1	19,000	21
Event 2	12,000	6
Event 3	1,900	6.4
Event 4	4,900	1.3

PCE	Soil Gas ug/m3	Indoor Air ug/m3
Event 1	3,500	36
Event 2	6,300	10
Event 3	6,000	6.6
Event 4	5,100	1.3

PCE	Soil Gas ug/m3	Indoor Air ug/m3
Event 1	220,000	250
Event 2	260,000	11
Event 3	230,000	12
Event 4	170,000	7.6

PCE	Soil Gas ug/m3	Indoor Air ug/m3
Event 1	75,000	330
Event 2	130,000	12
Event 3	220,000	8.4
Event 4	86,000	2.6

PCE	Soil Gas ug/m3	Indoor Air ug/m3
Event 1	19,000	310
Event 2	21,000	12
Event 3	20,000	6.2
Event 4	18,000	1.3

PCE	Soil Gas ug/m3	Indoor Air ug/m3
Event 1	11,000	310
Event 2	11,000	13
Event 3	16,000	6.5
Event 4	14,000	3.4

PCE	Soil Gas ug/m3	Indoor Air ug/m3
Event 1	380	24
Event 2	4,600	4.1
Event 3	1,300	6.5
Event 4	900	1.4

PCE	Soil Gas ug/m3	Indoor Air ug/m3
Event 1	230,000	310
Event 2	220,000	11
Event 3	100,000	9.2
Event 4	47,000	4.4

PCE	Soil Gas ug/m3	Indoor Air ug/m3
Event 1	55,000	330
Event 2	64,000	9.7
Event 3	27,000	6
Event 4	54,000	2.6

Legend

⊗ 948-## Sub-slab/Indoor Air Location

Exceeds TSRIASL₁₂

Exceeds Dow OEL

Media	COC	RIASL ₁₂	TSRIASL ₁₂	OEL
Soil Gas	PCE	2,700	2,700	--
Indoor Air	PCE	82	82	67,800

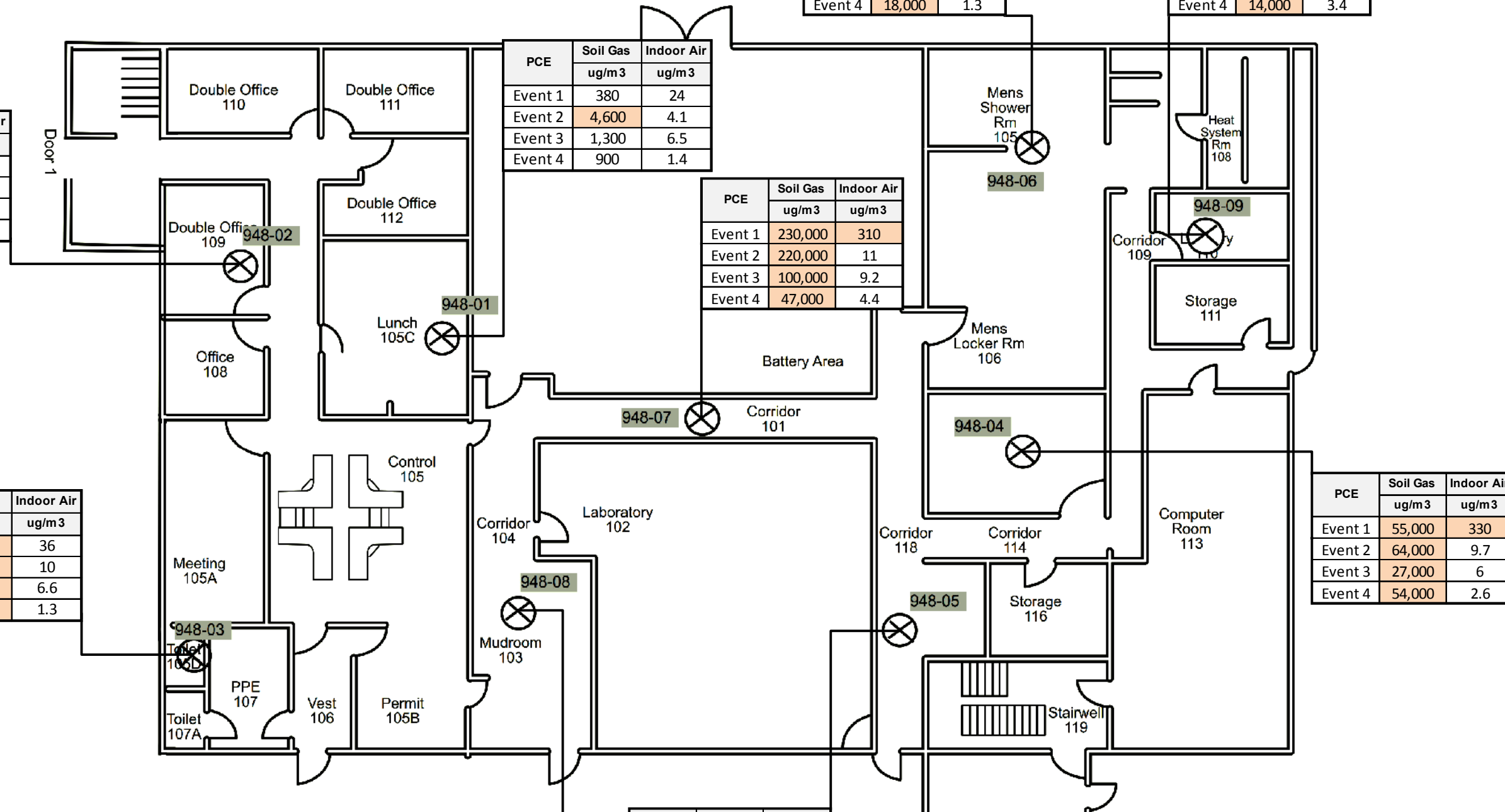

Notes:

All units ug/m3

Initial Sampling Event (1) = October 2017

Seasonal Confirmation Sampling Event 2 = March 2018

Seasonal Confirmation Sampling Event 3 = August 2018

Seasonal Confirmation Sampling Event 4 = October 2018

Outdoor air location collected on W side of building near Door 6. Note another intake located on roof to SE of wash bay area, points NE.

PCE	Outdoor Air Sample ug/m3
Event 1	5.1
Event 2	5.4
Event 3	4.9
Event 4	0.24

Sub-slab Soil Gas and Indoor Air Results for Tetrachloroethene Zone 2 Phase 2 Sampling Events 1 - 4 Building 948

5.3.7 Vapor Intrusion Evaluation for Building 1025

BACKGROUND

Building 1025 is a Category 2 building in Zone 2 (Figure 5.3.7-1). The results of the initial sampling event (Spring 2017) were evaluated in Section 5.4.7 of the 2017 CAIP and results of the add-on sampling event was evaluated in Section 5.2.5 of the 2018 CAIP. Building 1025 is a medium-sized single-story office building and is known as the Building 1025 Office Building. It is approximately 8,350 ft² and is located within the central portion of the facility designated as Zone 2. The initial evaluation in the 2017 CAIP concluded that based on the indoor air results, the VI pathway at Building 1025 was an insignificant exposure pathway based on current use. Building 1025 was placed into VI Path Forward Building Group 1 and no further VI evaluation was warranted at that time.

The results from the initial sampling event were rescreened. No indoor air analytes were detected above screening levels at Building 1025. Therefore, no EBS was necessary. Due to three sub-slab soil gas analytes with results that exceed the screening level, Building 1025 was moved into VI Path Forward Building Group 2 and seasonal confirmation sampling will be performed.

During follow-up discussions with building representatives, it was determined that an area of the building assumed to be infrequently used was an area of high use. The number of samples collected in the initial sampling event was based on the total square footage of the building, as per MDEQ guidance but they were placed in the areas of the building anticipated to be in the highest use. In Fall 2017, an additional three samples were collected in the large southern room and the data sets were combined for this evaluation.

DATA SUMMARY

Building 1025 has undergone three seasonal confirmation sampling events. Seasonal confirmation sampling was conducted at Building 1025 since results from the initial sampling event exceeded screening levels. The analytical results from each of the sampling events were compared to the June 22, 2018 EGLE draft project-specific 12-hour Soil Gas screening values and AACs (draft project-specific RIASL₁₂ and TSRIASL₁₂, if available).

Building 1025	
Initial Sampling Event	Completed
E1	April 2017 (Spring)/November 2017 (Add-on)
Seasonal Sampling Event	Completed
E2	February 2019 (Winter)
E3	August 2019 (Summer)
E4	Scheduled - Fall 2019

For each sampling event, sub-slab soil gas samples were collected from nine locations from within the building. Indoor air samples were collected at nine locations corresponding to the soil gas sample locations, along with an outdoor air sample from the main air intake. The sampling locations are shown on Figure 5.3.7-2. Summary statistics and screening comparison results are presented for sub-slab soil gas on Table 5.3.7-A and indoor and outdoor air on Table 5.3.7-B. The analytical data is presented in Appendix A. Field sampling forms are provided in Appendix B.

The building survey completed before the initial sampling event can be found in Appendix D. Drains and other openings were screened with a PID and no soil gas entry points were identified. A chemical inventory was completed during the building survey and the chemicals found to be stored within the building are listed in the survey.

SUB-SLAB SOIL GAS RESULTS EVALUATION

Analytical results were evaluated based on methodologies presented in the 2018 Revised Vapor Intrusion Work Plan. The number of analytes detected above the sub-slab soil gas draft project-specific RIASL₁₂ or TSRIASL₁₂, if available, are discussed below by sampling event and shown on Table 1025-1:

1. During the initial event (Spring 2017 with an add-on event in Fall 2017), four analytes were detected above the draft project-specific RIASL₁₂, including PCE which was also above the TSRIASL₁₂;
2. During the second event (Winter 2019), one analyte, PCE, was detected above the draft project specific RIASL₁₂ and TSRIASL₁₂; and
3. During the third event (Summer 2019), three analytes were detected above the draft project-specific RIASL₁₂, including PCE which was also above the TSRIASL₁₂.

Table 1025-1. Summary of Sub-Slab Soil Gas Exceedances for Building 1025

Analyte (Sampling Event)	Detection Frequency	Measured Range of Detects ($\mu\text{g}/\text{m}^3$)	% Detections > Screening Level	Screening Level* ($\mu\text{g}/\text{m}^3$)
1,1-Dichloroethane (1)	66%	7.4 - 3,300	11%	2,500
1,1-Dichloroethane (2)	78%	3.9 - 520	0%	2,500
1,1-Dichloroethane (3)	67%	4.6 - 4,700	11%	2,500
Chloroform (1)	44%	4.7 - 100	0%	170
Chloroform (2)	67%	3.8 - 23	0%	170
Chloroform (3)	67%	4.9 - 200	11%	170
Ethylbenzene (1)	89%	9.6 - 11,000	22%	1,600
Ethylbenzene (2)	78%	9.6 - 380	0%	1,600
Ethylbenzene (3)	78%	32 - 1,100	0%	1,600
Tetrachloroethene (1)	89%	340 - 6,600	11%	2,700
Tetrachloroethene (2)	100%	56 - 5,700	11%	2,700
Tetrachloroethene (3)	100%	130 - 19,000	11%	2,700
Total xylenes (1)	100%	41 - 47,000	11%	22,000
Total xylenes (2)	78%	35 - 2140	0%	22,000
Total xylenes (3)	89%	7 - 7,300	0%	22,000

*Screening level provided is the draft project-specific RIASL₁₂.

EVALUATION OF VAPOR INTRUSION

Table 1025-2 summarizes the indoor air results relative to the sub-slab soil gas exceedances, since VI only potentially occurs if the analyte is present in both sub-slab soil gas and indoor air. Therefore, the table below provides the analytes detected above applicable screening levels in sub-slab soil gas as well as the corresponding indoor air sample results. The outdoor air sample results are also provided to determine if the analytes were present in indoor air due to migration from outdoor air.

Table 1025-2. Vapor Intrusion Evaluation for Building 1025

Analyte (Sampling Event)	Indoor Air Detection Frequency	Indoor Air Measured Range ($\mu\text{g}/\text{m}^3$)	Indoor Air Screening Level* ($\mu\text{g}/\text{m}^3$)	Outdoor Air Result ($\mu\text{g}/\text{m}^3$)
1,1-Dichloroethane (1)	0%	ND	74	ND
1,1-Dichloroethane (2)	0%	ND	74	ND
1,1-Dichloroethane (3)	0%	ND	74	ND
Chloroform (1)	100%	0.18 - 3.2	5.2	ND
Chloroform (2)	100%	0.35 - 1.3	5.2	0.3
Chloroform (3)	100%	0.72 - 4.2	5.2	0.17

Table 1025-2. Vapor Intrusion Evaluation for Building 1025 (Continued)

Analyte (Sampling Event)	Indoor Air Detection Frequency	Indoor Air Measured Range ($\mu\text{g}/\text{m}^3$)	Indoor Air Screening Level* ($\mu\text{g}/\text{m}^3$)	Outdoor Air Result ($\mu\text{g}/\text{m}^3$)
Ethylbenzene (1)	100%	0.44 - 1.5	48	0.47
Ethylbenzene (2)	100%	0.62 - 1.6	48	0.38
Ethylbenzene (3)	100%	0.44 - 1.5	48	0.17
Tetrachloroethene (1)	100%	3.4 - 6.9	82	2.1
Tetrachloroethene (2)	100%	20 - 50	82	2.1
Tetrachloroethene (3)	100%	0.76 - 3.2	82	1.3
Total xylenes (1)	100%	2.3 - 9.9	680	0.89
Total xylenes (2)	100%	2.4 - 5.8	680	1.2
Total xylenes (3)	100%	1.8 - 6.2	680	0.47

*Screening level provided is the draft project-specific RIASL₁₂.

All indoor air results are less than screening levels. While detections of 1,1-DCA exceeded screening levels in sub-slab soil gas, it was not detected in indoor air. Detections of chloroform, ethylbenzene, PCE and total xylenes in outdoor air demonstrate evidence of influence on indoor air. All results in indoor air are <1% of the Dow OEL. A full ND evaluation will be performed upon the completion of seasonal confirmation sampling in the 2020 CAIP.

CONCLUSIONS AND RECOMMENDATIONS

Based on the indoor air results, the VI pathway at Building 1025 is an insignificant exposure pathway based on current use. However, based on the sub-slab soil gas results and given the potential for future VI, Building 1025 has been placed in VI Path Forward Building Group 2, as lines of evidence indicate that VI is insignificant. The final seasonal confirmation sampling event is scheduled for Fall 2019. A full evaluation will be presented in the 2020 CAIP.

5.3.8 VI Seasonal Confirmation Sampling Results Evaluation for Building 768

INTRODUCTION

Building 768 is a Category 2 building in Zone 2 Phase 1. Building 768 is approximately 14,090 ft² and has a warehouse, laboratory, and process area with office space. It is known as the Pilot Plant Office/Lab and is located within the central portion of the facility designated as Zone 2 (Figure 5.3.8-1).

The initial evaluation in the 2017 CAIP concluded that based on the indoor air results, the VI pathway at Building 768 is an insignificant exposure pathway based on current use and was placed into VI Path Forward Building Group 1 and no further VI evaluation was warranted at this time. The results from the initial sampling event were re-evaluated in the 2018 Rescreen Report and presented again in the 2018 CAIP. No indoor air analytes were detected above screening levels at Building 768; however, based on sub-slab soil gas results greater than screening levels for chloroform, TCE and PCE, Building 768 was moved into VI Path Forward Building Group 2 and seasonal confirmation sampling was conducted.

Building 768	
Initial Sampling Event	Completed
E1	April 2017 (Spring)
Seasonal Sampling Event	Completed
E2	October 2018 (Fall)
E3	February 2019 (Winter)
E4	August 2019 (Summer)

Based on the evaluation of the four seasonal confirmation sampling events, the VI pathway continues to be insignificant. Sufficient information exists to make a human exposure under control EI determination.

SUB-SLAB SOIL GAS RESULTS EVALUATION

Sub-slab soil gas samples were collected from six locations from within the building. Indoor air samples were collected at six locations corresponding to the soil gas sample locations, along with an outdoor air sample from the main air intake. The sampling locations are shown on Figure 5.3.8-2. Summary statistics and screening comparison results are presented for sub-slab soil gas on Table 5.3.8-A and indoor and outdoor air on Table 5.3.8-B. The analytical reports for the sub-slab soil gas and indoor and outdoor air samples are presented in Appendix A. Field sampling logs are presented in Appendix B. Table 768-1 presents the sub-slab soil gas results that exceed the draft project-specific screening levels. TCE and PCE also had exceedances greater than the sub-slab soil gas TSRIASL₁₂.

Table 768-1. Summary of Sub-Slab Soil Gas Exceedances for Building 768

Analyte (Sampling Event)	Detection Frequency	Measured Range of Detects ($\mu\text{g}/\text{m}^3$)	% Detections > Screening Level	Screening Level* ($\mu\text{g}/\text{m}^3$)
Chloroform (1)	83%	39 - 360	17%	170
Chloroform (2)	83%	23 - 340	17%	170
Chloroform (3)	83%	28 - 330	17%	170
Chloroform (4)	100%	17 - 630	50%	170
Tetrachloroethene (1)	100%	69 - 2,600	0%	2700
Tetrachloroethene (2)	100%	90 - 3,200	17%	2700
Tetrachloroethene (3)	100%	48 - 2,800	17%	2700
Tetrachloroethene (4)	100%	74 - 2,800	17%	2700
Trichloroethene (1)	83%	63 - 410	67%	130
Trichloroethene (2)	83%	37 - 480	67%	130
Trichloroethene (3)	83%	21 - 370	67%	130
Trichloroethene (4)	100%	12 - 340	67%	130

*Screening level provided is the draft project-specific RIASL₁₂.

Table 768-2 summarizes the indoor air results relative to the sub-slab soil gas exceedances, since VI only potentially occurs if the analyte is present in both sub-slab soil gas and indoor air. Therefore, the table below provides the analyte detected above applicable screening levels in sub-slab soil gas as well as the corresponding indoor air sample result. The outdoor air sample result is also provided to determine if the analytes were present in indoor air due to migration from outdoor air.

Table 768-2. Vapor Intrusion Evaluation for Building 768

Analyte	Indoor Air Detection Frequency	Indoor Air Measured Range ($\mu\text{g}/\text{m}^3$)	Indoor Air Screening Level* ($\mu\text{g}/\text{m}^3$)	Outdoor Air Result ($\mu\text{g}/\text{m}^3$)
Chloroform (1)	33%	0.33 - 0.49	5.2	0.15
Chloroform (2)	83%	0.18 - 1	5.2	ND
Chloroform (3)	83%	0.17 - 0.46	5.2	0.17
Chloroform (4)	83%	0.16 - 3.9	5.2	ND
Tetrachloroethene (1)	17%	0.96	82	0.96
Tetrachloroethene (2)	17%	0.84	82	0.84
Tetrachloroethene (3)	50%	0.26 - 0.31	82	0.31
Tetrachloroethene (4)	100%	0.39 - 5.2	82	5.2
Trichloroethene (1)	17%	0.19	4	ND
Trichloroethene (2)	33%	0.23 - 0.34	4	ND
Trichloroethene (3)	0%	ND	4	0.37
Trichloroethene (4)	17%	0.98	4	ND

*Screening level provided is the draft project-specific RIASL₁₂.

All indoor air results for Building 768 are below screening levels.

VAPOR INTRUSION CONCEPTUAL SITE MODEL

VI is an exposure pathway that results from the migration of volatilized chemicals from the subsurface to indoor air in overlying occupied buildings. A source, migration route and a human receptor must be present for the VI pathway to be complete. The focus of this building specific investigation is to evaluate the potential VI exposure pathway for employees and contractors at Building 768. The CSM is illustrated in Figure 5.3.8-3.

Building 768 is a warehouse, laboratory, and process area with office space. It is known as the Pilot Plant Office/Lab and is approximately 14,090 ft². The process and warehouse area is two stories tall but the office space is on the first story. The building has a central AC unit with one air intake at the top of the building in the center of the roof. There is a kitchen range hood fan in the kitchen space. The process area portion of the building has an elevator. There are six bay doors but they are all located in the process/warehouse portion of the building. These bay doors are only left open in hot weather during the summer. The land surrounding the building is covered in asphalt.

Approximately 20-25 people occupy Building 768. The building is occupied from 8am to 5pm Monday through Friday by office personnel and by operations personnel for three 8-hour shifts per day Monday through Friday. The typical parameters for non-residential exposures are assumed to apply to the various security personnel stationed during rotating work shifts at this building (i.e., 40 hours/week, 50 weeks/year exposure).

A building survey was completed before the initial sampling event. Drains and other openings were screened with a PID and no soil gas entry points were identified. A chemical inventory was completed during the building survey that identified cleaners, degreasers, and rust cutting spray.

EVALUATION OF SEASONAL CONFIRMATION SAMPLING EVENTS

Four seasonal sampling events have been completed at Building 768. The sampling events encompass more than one year of time and include sampling during each season of the year. The results from the four seasonal confirmation sampling events were evaluated with respect to spatial variability, temporal variability, and seasonal trend analysis.

Building specific attenuation factors (α) were calculated and compared between events to evaluate temporal variability and determine the best estimate of a building-specific attenuation factor. This evaluation serves to confirm that the existing study design is appropriate, and also provides insight for the determination of the path forward for this building.

This evaluation focused on any analytes detected in the sub-slab soil gas samples that met the criterion for inclusion in one or more of the following categories:

- a) Analytes detected in sub-slab soil-gas at concentrations that exceeded draft project-specific screening levels;
- b) Analytes detected in sub-slab soil-gas at concentrations of 1,000 $\mu\text{g}/\text{m}^3$ or greater in one or more samples. Data for analytes detected above 1,000 $\mu\text{g}/\text{m}^3$ should provide the clearest signal and be the simplest to interpret when assessing data trends. The same data trends observed for these analytes are expected to apply to other similar analytes present at lower concentrations; and
- c) PCE and TCE. These two analytes are of particular interest for many VI evaluations at industrial sites.

For this building, the only analytes detected in the sub-slab soil gas at concentrations above the draft project-specific screening levels were chloroform, PCE, and TCE. The only other analyte detected at concentrations $\geq 1,000 \mu\text{g}/\text{m}^3$ in soil gas was CFC-12. Sample results for these analytes are provided in the following data tables below:

Summary of Results for Chloroform

Sample Type	Sample ID	Measured Concentration ($\mu\text{g}/\text{m}^3$)			
		Apr. 2017	Oct. 2018	Feb. 2019	Aug. 2019
		E1	E2	E3	E4
Outdoor Air	768-OA-01	0.15	<0.15	0.17	<0.17
Indoor Air	768-IA-01	<0.33	0.20	<0.17	0.16
	768-IA-02	0.33	1	0.32	1.1
	768-IA-03	<0.16	0.18	0.18	0.22
	768-IA-04	<0.16	0.18	0.17	0.18
	768-IA-05	<0.16	<0.19	0.17	<0.19
	768-IA-06	0.49	1	0.46	3.9
Sub-Slab Soil Gas	768-SS-01	<25	<25	<8.7	17
	768-SS-02	72	42	47	530
	768-SS-03	39	29	28	75
	768-SS-04	71	51	39	32
	768-SS-05	360	340	330	370
	768-SS-06	52	23	48	630

Screening levels for indoor air are $5.2 \mu\text{g}/\text{m}^3$ (RIASL₁₂) and $52 \mu\text{g}/\text{m}^3$ (TSRIASL₁₂)
Screening levels for soil-gas are $170 \mu\text{g}/\text{m}^3$ (RIASL₁₂) and $1,700 \mu\text{g}/\text{m}^3$ (TSRIASL₁₂)

Summary of Results for Tetrachloroethene (PCE)

Sample Type	Sample ID	Measured Concentration ($\mu\text{g}/\text{m}^3$)			
		Apr. 2017	Oct. 2018	Feb. 2019	Aug. 2019
		E1	E2	E3	E4
Outdoor Air	768-OA-01	0.33	<0.21	0.34	0.28
Indoor Air	768-IA-01	<0.46	<0.22	<0.24	0.41
	768-IA-02	<0.22	<0.22	0.26	0.51
	768-IA-03	<0.23	<0.23	0.26	5.2
	768-IA-04	<0.22	<0.22	<0.22	0.48
	768-IA-05	<0.23	<0.26	<0.23	0.39
	768-IA-06	0.96	0.84	0.31	4.2
Sub-Slab Soil Gas	768-IA-01	69	90	48	74
	768-IA-02	410	400	250	680
	768-IA-03	820	680	730	690
	768-IA-04	630	900	730	710
	768-IA-05	2,600	3,200	2,800	2,800
	768-IA-06	1,100	1,000	960	1,800

Screening level for indoor air is $82 \mu\text{g}/\text{m}^3$ (RIASL₁₂ and TSRIASL₁₂)
Screening level for soil-gas is $2,700 \mu\text{g}/\text{m}^3$ (RIASL₁₂ and TSRIASL₁₂)

	RIASL12 Exceedance
	TSRIASL12 Exceedance

Summary of Results for Trichloroethene (TCE)

Sample Type	Sample ID	Measured Concentration ($\mu\text{g}/\text{m}^3$)			
		Apr. 2017	Oct. 2018	Feb. 2019	Aug. 2019
		E1	E2	E3	E4
Outdoor Air	768-OA-01	<0.17	<0.16	0.37	<0.19
Indoor Air	768-IA-01	<0.36	0.34	<0.19	<0.18
	768-IA-02	<0.18	<0.18	<0.17	<0.18
	768-IA-03	<0.18	<0.18	<0.18	<0.22
	768-IA-04	<0.17	<0.18	<0.17	<0.18
	768-IA-05	<0.18	<0.21	<0.18	<0.20
	768-IA-06	0.19	0.23	<0.18	0.98
Sub-Slab Soil Gas	768-SS-01	<27	<28	<9.6	12
	768-SS-02	63	37	21	120
	768-SS-03	400	340	350	300
	768-SS-04	410	480	370	320
	768-SS-05	280	300	270	260
	768-SS-06	200	180	170	340

Screening levels for indoor air are $4 \mu\text{g}/\text{m}^3$ (RIASL₁₂) and $12 \mu\text{g}/\text{m}^3$ (TSRIASL₁₂)
Screening levels for soil-gas are $130 \mu\text{g}/\text{m}^3$ (RIASL₁₂) and $400 \mu\text{g}/\text{m}^3$ (TSRIASL₁₂)

Summary of Results for Chlorofluorocarbon (CFC-12)

Sample Type	Sample ID	Measured Concentration ($\mu\text{g}/\text{m}^3$)			
		Apr. 2017	Oct. 2018	Feb. 2019	Aug. 2019
		E1	E2	E3	E4
Outdoor Air	768-OA-01	2.2	2.1	1.9	2
Indoor Air	768-IA-01	3	3.1	2.4	2.6
	768-IA-02	2.6	2.6	2.3	2.6
	768-IA-03	2.6	2.5	2.3	2.6
	768-IA-04	2.6	2.4	2.3	2.6
	768-IA-05	2.4	2.3	2.2	2.6
	768-IA-06	3.5	3.1	3.1	2.6
Sub-Slab Soil Gas	768-SS-01	6,000	6,800	1,700	2,300
	768-SS-02	1,200	5,000	670	2,000
	768-SS-03	1,400	6,000	1,600	2,900
	768-SS-04	3,300	7,300	1,700	5,500
	768-SS-05	960	2,500	410	1,200
	768-SS-06	210	1,100	510	220

Screening levels for indoor air are $1020 \mu\text{g}/\text{m}^3$ (RIASL₁₂)
Screening levels for soil-gas are $34,000 \mu\text{g}/\text{m}^3$ (RIASL₁₂)

	RIASL12 Exceedance
	TSRIASL12 Exceedance

EVALUATION OF VI DATA TRENDS

Data trends for Building 768 are discussed below for both sub-slab soil gas and indoor air. When data exhibit a narrow range of variability, it is typical practice to express the range as a percentage (e.g., RPD). When data exhibit a large range of variability, however, it is more useful to express the range in orders of magnitude (i.e., factors of 10). This can be expressed mathematically as the log of the ratio of maximum/minimum values. If the values differ by a factor of 10, the log of the ratio is 1, if the values differ by a factor of 100, the log of the ratio is 2, and so on.

The variability across all locations over all sampling events is the total variability. This encompasses different types of variability, including spatial variability (i.e., how do the results vary from location to

location), temporal variability (i.e., how do the results at a given location vary over time), and measurement variability. Measurement variability can be determined by evaluating results of duplicate or collocated samples and includes both sampling variability and analytical variability.

Sub-Slab Soil Gas Data Trends

Spatial Variability of Sub-Slab Soil Gas – The soil gas exhibit less than two orders of magnitude of spatial variability. For example, sub-slab soil gas detections of chloroform vary from 17 to 630 $\mu\text{g}/\text{m}^3$ (log of max./min. = 1.6) across all six locations for E4. Sub-slab detections of PCE vary from 90 to 3,200 $\mu\text{g}/\text{m}^3$ (log max./min. = 1.6) across all six locations for E2. The spatial variability is slightly lower for TCE and CFC-12. Based on this data, there is a relatively modest amount of spatial variability in sub-slab soil gas given the size of the building and the number of sampling locations.

Temporal Variability of Soil Gas – The soil gas concentrations exhibit, at most, slightly more than one order of magnitude of temporal variability. For example, sub-slab soil gas concentrations of chloroform vary from 23 to 630 $\mu\text{g}/\text{m}^3$ at location 768-SS-06 (log max/min = 1.4) and from 32 to 71 $\mu\text{g}/\text{m}^3$ at location 768-SS-02 (log max/min = 0.35). For PCE, sub-slab soil gas concentrations vary from 960 to 1,800 $\mu\text{g}/\text{m}^3$ at location 768-SS-06 (log max/min = 0.27). For TCE, sub-slab soil gas concentrations vary from 170 to 340 $\mu\text{g}/\text{m}^3$ at location 768-SS-06 (log max/min = 0.3). Based on this evaluation, there is a relatively modest amount of temporal variability in sub-slab soil gas which is in-line with expectations. Overall, as expected, the amount of temporal variability is less than the amount of spatial variability.

Seasonal Confirmation Sampling Trend Analysis – No formal statistical tests were performed, but the data exhibits relatively consistent results between the seasons. This is demonstrated by the graph below, which shows the four analytes selected above at locations where they were detected at relatively high concentrations. Note that the y-axis is a log scale.

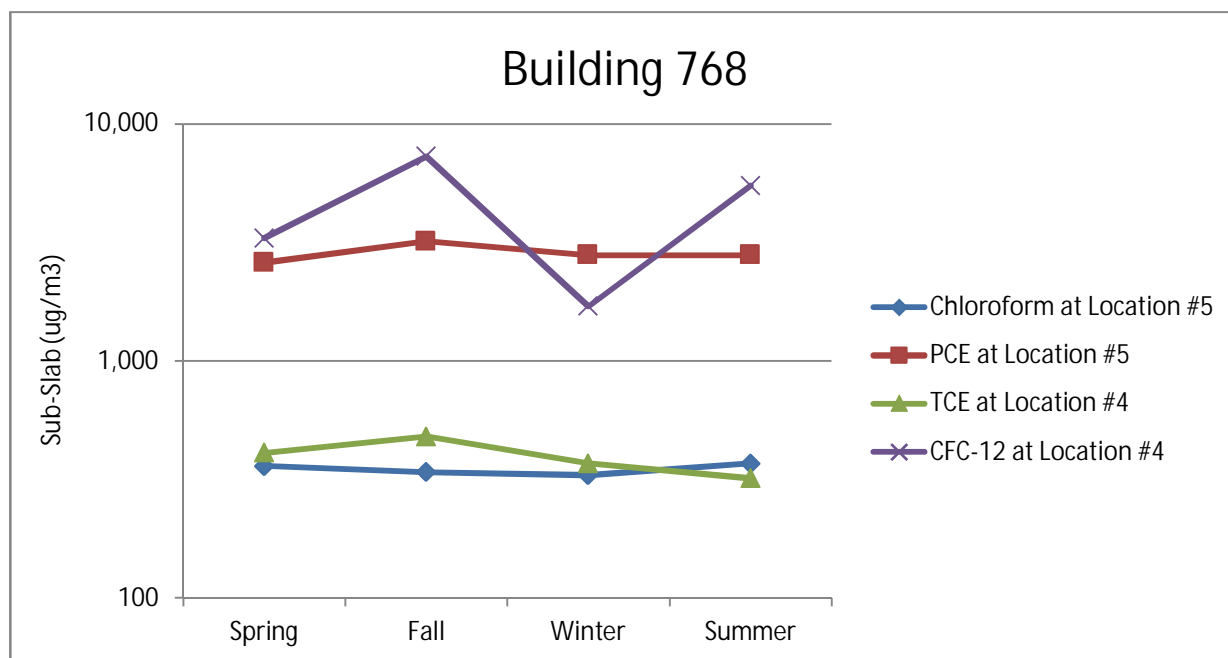

The data set was examined to see what the potential consequences would have been had only a single sampling event been performed. For PCE and TCE, the highest sub-slab soil gas concentrations were collected during the fall (E2) and the lowest concentrations occurred during the spring (E1) or summer (E4), respectively. For chloroform, the highest sub-slab concentration was collected during the summer (E4) and the lowest concentration occurred during the winter (E3). Overall, the minimum and maximum values appear to be consistent between sampling events.

For TCE, a concentration of 410 $\mu\text{g}/\text{m}^3$ was measured during E1 and the highest concentration (480 $\mu\text{g}/\text{m}^3$) was measured during E2. If only E1 had been performed, a negative bias of 17% would have been introduced (i.e., the E2 result was 17% higher than the E1 result). For PCE, the lowest value (2,600 $\mu\text{g}/\text{m}^3$) was measured during E1 and the highest concentration (3,200 $\mu\text{g}/\text{m}^3$) was measured during E2. If only E1 had been performed, a negative bias of 54% would have been introduced. Therefore, implementing four seasonal confirmation sampling events provided only limited insight regarding maximum concentration levels, but the larger data set served to increase the confidence in the findings including demonstrating the consistency of the maximum reported results.

Indoor Air Data Trends

Spatial Variability of Indoor Air – Since indoor air results for chloroform and TCE were predominantly ND, spatial variability was determined for PCE and CFC-12. PCE had 100% detection frequency during E4 and indoor air concentrations vary from 0.28 to 5.2 $\mu\text{g}/\text{m}^3$ (log max./min. = 1.1). The other events saw less variability. For CFC-12, the highest spatial variability occurred during E3 where indoor air concentrations vary from 2.2 to 3.1 $\mu\text{g}/\text{m}^3$ (log max./min. = 0.15). The CFC-12 data suggests the air within the building is well-mixed and influenced by outdoor air, since the concentrations of indoor and outdoor air are roughly equivalent.

Temporal Variability of Indoor Air – The indoor air has, at most, about one order of magnitude of temporal variability. For example, indoor air concentrations of PCE at location 768-IA-03 varied from 0.26 to 5.2 $\mu\text{g}/\text{m}^3$ (log of max./min. = 1.3). TCE at location 768-IA-06 varied from 0.19 to 0.98 $\mu\text{g}/\text{m}^3$ (log of max./min. = 0.7). For chloroform and CFC-12, the temporal variability is less with most values falling within about a factor of two. Overall, temporal variability across the four seasons sampled is relatively small.

Additional Analyses

Comparison of Sub-Slab Soil Gas and Indoor Air Data Sets – As expected, the sub-slab soil gas data exhibit greater spatial variability than the indoor air data set. The sub-slab soil gas also exhibit greater temporal variability than the indoor air data set, which is contrary to expectations. This suggests that there are not significant indoor sources of the AOIs or that emissions from any indoor air sources tend to be well distributed in this building. The comparisons, however, are limited by the large percentage of ND values in both the sub-slab and the indoor air data sets.

Seasonal Effects – The sub-slab soil gas data exhibit relatively little variability from event to event. Maximum soil-gas values for PCE, TCE, and CFC-12 were detected during E2 (i.e., fall). The indoor air data set is predominantly ND values, but the highest chloroform, PCE, and TCE values occurred during E4 (i.e., summer). The data do not support the hypothesis that wintertime should have the highest indoor air impacts.

Comparison of Attenuation Factors by Event – Attenuation factors were calculated for PCE based on maximum values since it had a 100% detection frequency in sub-slab soil gas, as well as 100% detection frequency in indoor air during E4 and minimal detections in outdoor air. The calculated event-specific attenuation factors are shown in the table below.

Comparison of Building-Specific Attenuation Factors by Event

	E1 (Spring)	E2 (Fall)	E3 (Winter)	E4 (Summer)
Maximum Values				
PCE in Sub-Slab Soil Gas ($\mu\text{g}/\text{m}^3$)	2,600	3,200	2,800	2,800
PCE in Indoor Air ($\mu\text{g}/\text{m}^3$)	0.96	0.84	0.31	5.2
Attenuation Factor	3.7E-04	2.6E-04	1.1E-04	1.9E-03

These serve as the best estimate of attenuation at this building. The results can vary from day to day due to differences in rates of VI and rates of building ventilation. Overall, the most conservative estimate of a building-specific attenuation factor for Building 768 is 1.9E-03 based on PCE during E4. The overall data set suggests that E4 reflects the contribution of indoor emission sources rather than increased rates of VI. For example, the highest indoor air impacts were at 768-IA-03, whereas 768-SS-03 did not have the highest soil gas impacts and was only about one-quarter of the concentration at 768-SS-05.

Temporal Variability in Attenuation Factor – As shown in Table 1, there was about one order of magnitude of temporal variability in the calculated attenuation factors observed for PCE.

To be as conservative as possible, the maximum values were used in calculating the attenuation factor for each event. All maximum sub-slab soil gas values are from sample location 768-SS-05 and all maximum indoor air values are from 768-IA-06, except for E4 where the maximum was 768-IA-03. In general, maximum concentrations were location-specific, but the low spatial variability in indoor air results means that roughly comparable attenuation factors would be obtained whichever indoor air value was used in the calculations.

NON-DETECT EVALUATION

1,1,2-TCA, 1,2-EDB, and HCBd are ND analytes in sub-slab soil gas with RLs that exceed screening levels. For 1,1,2-TCA, all sub-slab soil gas ND RLs met screening levels during E3 and all indoor air ND RLs met screening levels for all four events. For HCBd, all sub-slab soil gas ND RLs met screening levels during E3 and all indoor air ND RLs met screening levels during E4. All ND RLs in sub-slab soil gas for EDB exceed screening levels for all events; however, during E1 50% of the indoor air ND RLs for EDB met the screening level.

WEIGHT-OF-EVIDENCE SUMMARY

Building 768 was confirmed as a VI Path Forward Group 2 building due to its potential for VI based on sub-slab soil gas exceedances of the draft project-specific RIASL₁₂ and/or TSRIASL₁₂ for chloroform, TCE, and PCE. However, after further investigation and evaluation, the following evidence supports the conclusion that VI is insignificant at Building 768:

- No exceedances of draft project-specific screening levels in indoor air.
- The sub-slab soil gas data do not show any strong time dependence nor do the data show any strong seasonal effects.
- The data do not support the hypothesis that wintertime should have the highest indoor air impacts. The highest sub-slab soil gas concentrations generally were measured in the fall. Similarly, the highest indoor air concentrations were measured in the summer.
- The indoor air data show relatively little spatial variability, despite the greater spatial variability in the sub-slab soil gas values. This evaluation confirms that the sub-slab soil gas and indoor air concentrations were relatively constant from season to season.
- As shown in the table below, the building-specific attenuation factor yields estimated indoor air concentration for EDB well below the screening level.

Parameters	EDB
Building-specific AF	1.9E-03
Maximum detected concentration in SSSG (768-SS-04)	<47
Estimated Indoor Air Concentration	<0.089
Indoor Air ND RL at 768-IA-04	<0.25
Indoor Air RIASL ₁₂	0.2

Based on the CSM for Building 768, VI is an insignificant exposure pathway for current building utilization.

PATH FORWARD

Based on the evaluation of the four seasonal confirmation sampling events, the VI pathway continues to be insignificant for Building 768 and the sub-slab soil gas results have demonstrated relatively stable concentrations and no evidence of increasing over time. Sufficient information exists to make a human exposure under control EI determination. However, while currently there is no evidence of potential VI, for future use, LTM is warranted and the building-specific Interim Monitoring Plan is discussed below.

Building-specific Interim Monitoring Plan

Dow will implement an Interim Monitoring Plan at Building 768 until a revised program or more permanent Corrective Action Plan is developed for the site.

Indoor air will be monitored at location 768-IA-04. This location was selected for continued monitoring since it demonstrated the highest sub-slab soil gas results. Monitoring will be performed for chloroform, PCE, and TCE. An outdoor air sample will also be collected at the time of each monitoring event. Interim monitoring will be performed semi-annually for a minimum of two years and monitoring results will undergo trend analysis. Monitoring will begin summer of 2020. If results continue to be consistent and below screening levels, monitoring will be conducted on an annual basis. If indoor air results are observed to be increasing, further evaluation will be performed, which may include collection of a sub-slab soil gas sample(s) and an increase in monitoring frequency. Results from each monitoring event will be reported in the annual CAIP. In the event an indoor air result(s) exceeds screening levels, EGLE will be provided a brief email notification. A collocated indoor air and sub-slab soil gas sample will be collected from that location within 45 days. If both sub-slab soil gas and indoor air results indicate that VI continues to be insignificant, monitoring will continue at an appropriate frequency. If both sub-slab soil gas and indoor air results indicate that VI is significant and confirm Group 4 conditions, the building will be moved to Group 4 for follow-up actions.

Dow may propose changes to the frequency or other aspects of this Interim Monitoring Plan in the future based on an evaluation of the data, changes in building use or implementation of other corrective actions to address the potential VI pathway.

5.3.9 VI Seasonal Confirmation Sampling Results Evaluation for Building 849

INTRODUCTION

Building 849 is a Category 2 building in Zone 2. This building is a warehouse with a small office. It is known as the 849 Building Warehouse and is located within the western portion of the facility designated as Zone 2 (Figure 5.3.9-1).

The initial evaluation in the 2017 CAIP concluded that the VI pathway at Building 849 is an insignificant exposure pathway based on current use and the building was placed into VI Path Forward Building Group 1 and no further VI evaluation was warranted. The results from the initial sampling event (E1) (Spring 2017) were re-evaluated in the 2018 Rescreen Report (August 2018) and presented again the 2018 CAIP and based on the single exceedance of ethylbenzene in sub-slab soil gas, the building was moved into VI

Path Forward Building Group 2. Group 2 is a designation for buildings that have sub-slab soil gas AOI(s), but all indoor air results are less than screening levels and are scheduled for seasonal confirmation sampling.

The remaining three seasonal confirmations sampling events have been completed and the results of all four events are included and evaluated herein. No indoor air analytes were detected above screening levels. Ethylbenzene was the only analyte in sub-slab soil gas with exceedances of the draft project-specific RIASL₁₂. There were no sub-slab soil gas results above the TSRIASL₁₂ at Building 849.

Building 849	
Initial Sampling Event	Completed
E1	April 2017 (Spring)
Seasonal Sampling Event	Completed
E2	October/November 2018 (Fall)
E3	February 2019 (Winter 2019)
E4	August 2019 (Summer)

Based on the evaluation of the four seasonal confirmation sampling events, the VI pathway continues to be insignificant. Sufficient information exists to make a human exposure under control EI determination.

SUB-SLAB SOIL GAS RESULTS EVALUATION

Sub-slab soil gas samples were collected from six locations from within the building. Indoor air samples were collected at six locations corresponding to the soil gas sample locations, along with one outdoor air sample. The sampling locations are shown on Figure 5.3.9-2. Summary statistics and screening comparison results are presented for sub-slab soil gas on Table 5.3.9-A and indoor and outdoor air on Table 5.3.9-B. The analytical reports are presented in Appendix A. Field sampling logs are provided in Appendix B. Table 849-1 presents the sub-slab soil gas results that exceed the draft project-specific RIASL₁₂.

Table 849-1. Summary of Sub-Slab Soil Gas Detects for Building 849

Analyte	Detection Frequency	Measured Range of Detects (µg/m ³)	% Detections > Screening Level	Screening Level* (µg/m ³)
Ethylbenzene (1)	100%	8.8 - 2,100	17%	1,600
Ethylbenzene (2)	67%	7.1 - 79	0%	1,600
Ethylbenzene (3)	83%	6.9 - 180	0%	1,600
Ethylbenzene (4)	67%	5.4 - 1,500	0%	1,600

*Screening level provided is the draft project-specific RIASL₁₂.

Table 849-2 summarizes the indoor air results relative to the sub-slab soil gas exceedances, since VI only potentially occurs if the analyte is present in both sub-slab soil gas and indoor air. Therefore, the table below provides the analytes detected above applicable screening levels in sub-slab soil gas as well as the corresponding indoor air sample results. The outdoor air sample results are also provided to determine if the analytes were present in indoor air due to migration from outdoor air.

Table 849-2. Vapor Intrusion Evaluation for Building 849

Analyte	Indoor Air Detection Frequency	Indoor Air Measured Range ($\mu\text{g}/\text{m}^3$)	Indoor Air Screening Level* ($\mu\text{g}/\text{m}^3$)	Outdoor Air Result ($\mu\text{g}/\text{m}^3$)
Ethylbenzene (1)	100%	0.36 - 1.4	48	ND
Ethylbenzene (2)	100%	0.22 - 1	48	ND
Ethylbenzene (3)	100%	0.20 - 0.89	48	ND
Ethylbenzene (4)	100%	0.43 - 3.6	48	1.2

*The screening level provided is the draft project-specific RIASL₁₂.

All indoor air results for Building 849 are below the screening level.

VAPOR INTRUSION CONCEPTUAL SITE MODEL

VI is an exposure pathway that results from the migration of volatilized chemicals from the subsurface to indoor air in overlying occupied buildings. A source, migration route and a human receptor must be present for the VI pathway to be complete. The focus of this building specific investigation is to evaluate the potential VI exposure pathway for Dow employees and contractors at Building 849. The CSM is illustrated in Figure 5.3.9-3.

Building 849 is a warehouse with a small office. It is approximately 8,360 ft² in size and sits on a 2.5 - 3 ft above grade slab. The building has two individual air conditioning units with the air intakes located on the roof and back end of building. This building has five bay doors, two on the east side and three on the west side. The land surrounding the building is covered in a combination of asphalt and gravel.

Approximately 5 people occupy Building 849. The building is occupied on Monday through Friday on an around the clock schedule of three eight-hour shifts. The building is a warehouse with small office set-up, and the occupants are only present sporadically throughout the shift (e.g., anywhere from 2-4 hours depending on duties). Therefore, typical parameters for non-residential exposures may overestimate time spent on duty in this building (i.e., 40 hours/week, 50 weeks/year exposure).

A building survey was completed before the initial sampling event. Drains and other openings were screened with a PID and no soil gas entry points were identified. A chemical inventory was completed during the building survey that identified cleaners, penetrating oil lubricant, and spray enamel and spray paint.

EVALUATION OF SEASONAL CONFIRMATION SAMPLING EVENTS

Four seasonal sampling events have been completed at Building 849. The sampling events encompass more than one year of time and include sampling during each season of the year. The results from the four seasonal confirmation sampling events were evaluated with respect to spatial variability, temporal variability, and seasonal trend analysis. The analysis was limited, however by the small number of VOCs and the lack of relatively high concentrations among the detected values.

This evaluation focused on any analytes detected in the sub-slab soil gas samples that met the criterion for inclusion in one or more of the following categories:

- a) Analytes detected in sub-slab soil gas at concentrations that exceeded draft project-specific screening levels;
- b) Analytes detected in sub-slab soil gas at concentrations of 1,000 micrograms per cubic meter ($\mu\text{g}/\text{m}^3$) or greater in one or more samples. Data for analytes detected above 1,000 $\mu\text{g}/\text{m}^3$ should provide the clearest signal and be the simplest to interpret when assessing data trends. The same data trends observed for these analytes are expected to apply to other similar analytes present at lower concentrations; and

- c) PCE and TCE. These two analytes are of particular interest for many VI evaluations at industrial sites.

For this building, ethylbenzene is the only analyte detected in the sub-slab soil gas at concentrations above the draft project-specific screening level. Total xylenes and toluene were detected at a concentration greater than or equal (\geq) to 1,000 $\mu\text{g}/\text{m}^3$ in soil gas; however toluene it is not included in the evaluation because it only had a single detect $>1,000 \mu\text{g}/\text{m}^3$. PCE and TCE are not included in this evaluation because they were either not detected in sub-slab soil gas or detected at very low concentrations. Sample results for ethylbenzene and total xylenes are provided in the following data tables.

Summary of Results for Ethylbenzene

Sample Type	Sample ID	Measured Concentration ($\mu\text{g}/\text{m}^3$)			
		Apr. 2017	Oct./Nov. 2018	Feb. 2019	Aug. 2019
		E1	E2	E3	E4
Outdoor Air	849-OA-01	<0.14	<0.18	<0.15	1.2
Indoor Air	849-IA-01	1.4	1	0.89	3.6
	849-IA-02	0.44	0.25	0.36	0.43
	849-IA-03	0.40	0.22	0.34	0.54
	849-IA-04	0.36	0.30	0.21	0.89
	849-IA-05	0.36	0.26	0.21	0.84
	849-IA-06	0.44	0.26	0.20	0.75
Sub-Slab Soil Gas	849-SS-01	2,100	79	180	1,500
	849-SS-02	330	13	9.5	23
	849-SS-03	15	<3.6	0.3	6.5
	849-SS-04	29	9.5	29	5.4
	849-SS-05	19	7.1	6.9	<3.3
	849-SS-06	8.8	<3.6	8	<3.8

Screening levels for indoor air are 48 $\mu\text{g}/\text{m}^3$ (RIASL₁₂) and 480 $\mu\text{g}/\text{m}^3$ (TSRIASL₁₂)
Screening levels for soil-gas are 1,600 $\mu\text{g}/\text{m}^3$ (RIASL₁₂) and 16,000 $\mu\text{g}/\text{m}^3$ (TSRIASL₁₂)

Summary of Results for Total Xylenes

Sample Type	Sample ID	Measured Concentration ($\mu\text{g}/\text{m}^3$)			
		Apr. 2017	Oct./Nov. 2018	Feb. 2019	Aug. 2019
		E1	E2	E3	E4
Outdoor Air	849-OA-01	0.4	0.27	0.395	5.2
Indoor Air	849-IA-01	5.1	4.03	3.53	14.3
	849-IA-02	1.2	0.81	1.02	1.52
	849-IA-03	1.05	0.64	0.91	1.66
	849-IA-04	1.17	0.82	0.78	3.04
	849-IA-05	1.19	0.79	0.72	3.02
	849-IA-06	1.43	0.78	0.8	2.74
Sub-Slab Soil Gas	849-SS-01	12,200	351	750	7,000
	849-SS-02	2,480	76	49	124
	849-SS-03	89	5.7	6.65	26.9
	849-SS-04	75	23.2	101	21.2
	849-SS-05	32	11	12.7	3.3
	849-SS-06	17.3	7.4	33.8	7.1

Screening levels for indoor air are 680 $\mu\text{g}/\text{m}^3$ (RIASL₁₂) and 2,000 $\mu\text{g}/\text{m}^3$ (TSRIASL₁₂)
Screening levels for soil-gas are 22,000 $\mu\text{g}/\text{m}^3$ (RIASL₁₂) and 67,000 $\mu\text{g}/\text{m}^3$ (TSRIASL₁₂)

	RIASL12 Exceedance
	TSRIASL12 Exceedance

VALUATION OF VI DATA TRENDS

Data trends for Building 849 are discussed below for both sub-slab soil gas and indoor air. When data exhibit a narrow range of variability, it is typical practice to express the range as a percentage. When data exhibit a large range of variability, however, it is more useful to express the range in orders of magnitude (i.e., factors of 10). This can be expressed mathematically as the log of the ratio of maximum/minimum values. If the values differ by a factor of 10, the log of the ratio is 1, if the values differ by a factor of 100, the log of the ratio is 2, and so on.

The variability across all locations over all sampling events is the total variability. This encompasses different types of variability, including spatial variability (i.e., how do the results vary from location to location), temporal variability (i.e., how do the results at a given location vary over time), and measurement variability. Measurement variability can be determined by evaluating results of duplicate or collocated samples and includes both sampling variability and analytical variability.

Sub-Slab Soil Gas Data Trends

Spatial Variability of Sub-Slab Soil Gas – The soil gas exhibit more than three orders of magnitude of spatial variability. For example, sub-slab soil gas detections of ethylbenzene vary from 8.8 to 2,100 $\mu\text{g}/\text{m}^3$ (log of max./min. = 2.4) across all six locations for E1. Sub-slab detections of total xylenes vary from 3.3 to 7,200 $\mu\text{g}/\text{m}^3$ (log max./min. = 3.3) across all six location for E4. Based on this data, the spatial variability in sub-slab soil gas is about as expected given the size of the building and the number of sampling locations.

Temporal Variability of Soil Gas – The soil gas concentrations exhibit a little more than one order of magnitude of temporal variability. For example, at location 849-SS-01, sub-slab soil gas concentrations of ethylbenzene vary from 79 to 2,100 $\mu\text{g}/\text{m}^3$ (log max/min = 1.4) and for total xylenes vary from 351 to 12,200 $\mu\text{g}/\text{m}^3$ (log max/min = 1.5). Overall, the amount of temporal variability is less than the amount of spatial variability.

Seasonal Confirmation Sampling Trend Analysis – No formal statistical tests were performed, but the data exhibits relatively consistent results between the seasons. This is illustrated in the graphs below. Plots for ethylbenzene and total xylenes are shown below for sample locations 849-SS-01 and 849-SS-02. Note that the y-axis is a log scale.

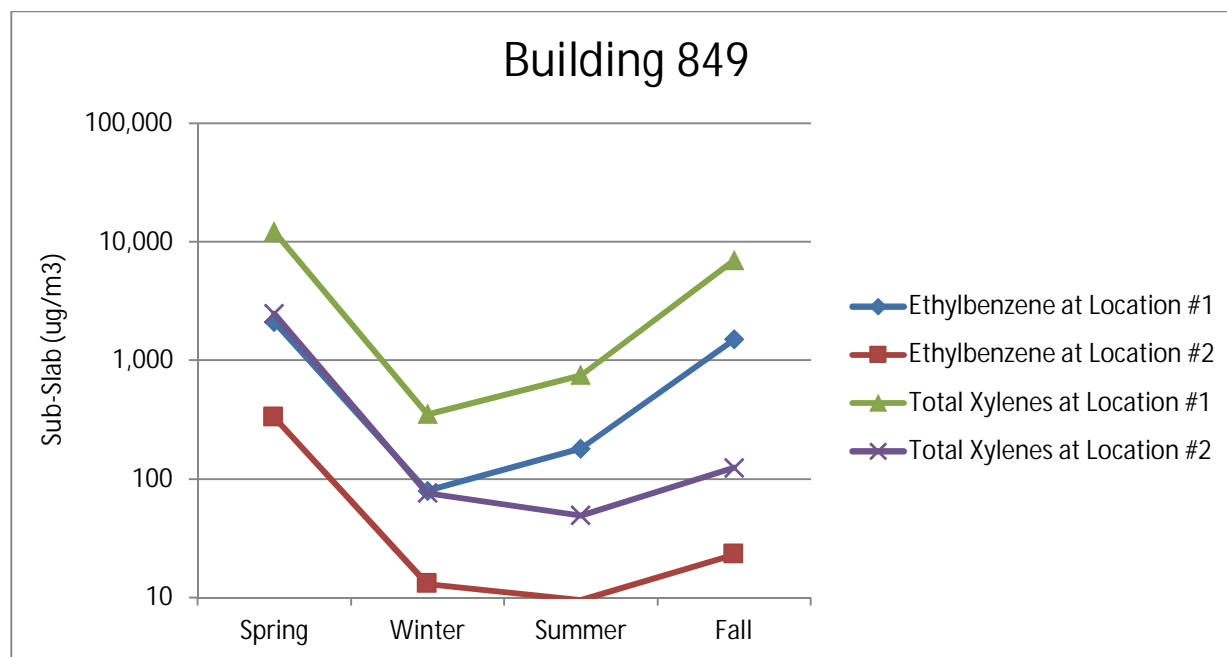

The data set was examined to see what the potential consequences would have been had only a single sampling event been performed. For ethylbenzene at 849-SS-01, the highest sub-slab concentration was collected during the spring (E1) and the lowest concentration occurred during the fall (E2). For total xylenes at 849-SS-01, the highest sub-slab concentration was also collected during the spring (E1) and the lowest concentration also occurred during the fall (E2). As the minimum and maximum values appear to be randomly distributed among the various sampling events, implementing four seasonal confirmation sampling events provided a larger data set and increased the confidence in the findings including demonstrating the maximum reported results were collected during the initial sampling event in the spring (E1).

Indoor Air Data Trends

Spatial Variability of Indoor Air – The indoor air exhibit up to one order of magnitude of spatial variability. For example, ethylbenzene was detected in 100% of indoor air samples and concentrations vary from 0.36 to 1.4 $\mu\text{g}/\text{m}^3$ (log max./min. = 0.6) during E1 and vary from 0.43 to 3.6 $\mu\text{g}/\text{m}^3$ (log max./min. = 0.9) during E4. For total xylenes, the highest spatial variability also occurred during E4 where indoor air concentrations vary from 1.52 to 14.3 $\mu\text{g}/\text{m}^3$ (log max./min. = 0.97).

Temporal Variability of Indoor Air – The indoor air exhibits less than an order of magnitude temporal variability. For example, the highest variability in indoor air concentrations of ethylbenzene occurred at location 849-IA-04 and varied from 0.21 to 0.89 $\mu\text{g}/\text{m}^3$ (log max./min. = 0.63). Ethylbenzene at location 849-IA-01 varied from 0.89 to 3.6 $\mu\text{g}/\text{m}^3$ (log max./min. = 0.61). Total xylenes was very similar and at location 849-IA-01 varied from 3.53 to 14.3 $\mu\text{g}/\text{m}^3$ (log max./min. = 0.61). Therefore, temporal variability across the four seasons sampled is considered to be relatively small.

Additional Analyses

Comparison of Sub-Slab Soil Gas and Indoor Air Data Sets – As expected, the sub-slab soil gas data exhibit greater spatial variability than the indoor air data set. However, the indoor air data exhibits less temporal variability than the sub-slab soil gas data set, which is contrary to expectations and suggests that ethylbenzene is not currently in use.

Seasonal Effects – The sub-slab soil gas data exhibit relatively little variability from event to event. The maximum soil-gas values for ethylbenzene and total xylenes were detected during E1 (i.e., spring). The highest ethylbenzene and total xylenes indoor air values occurred during E4 (i.e., summer). The data do not support the hypothesis that wintertime should have the highest indoor air impacts.

Comparison of Attenuation Factors by Event – Attenuation factors were not calculated for Building 849 due to limitations from the large percentage of ND values in both the sub-slab and the indoor air data sets (see discussion below).

NON-DETECT EVALUATION

In sub-slab soil gas, there were five ND analytes with RLs that exceeds the screening level: 1,1,2,2-tetrachloroethane (E1), 1,1,2-TCA (E1, E4), 1,2,4-TCB (E1), EDB (E1, E3, E4), and HCBd (E1, E4).

During E1, 849-SS-01 had a single ND RL greater than the respective screening levels for 1,1,2,2-tetrachloroethane ($74 \mu\text{g}/\text{m}^3$), 1,1,2-TCA ($59 \mu\text{g}/\text{m}^3$), 1,2,4-TCB ($320 \mu\text{g}/\text{m}^3$), and HCBd ($460 \mu\text{g}/\text{m}^3$); however, all sub-slab soil gas ND RLs at that same location for the following three sampling events were below the screening level, with the exception of E4 for 1,1,2-TCA and HCBd. No further ND RL evaluation is necessary for these analytes as they all have a 0% detection frequency for all sampling events and all ND RLs met the screening level during at least one event.

During E1, the ND RLs for EDB exceeded the screening level ($6.6 \mu\text{g}/\text{m}^3$); for all sampling locations except for 849-SS-04. All ND RLs met the screening levels in E2. Only a single ND RL for EDB at sample location 849-SS-04 was greater than the screening level in E3. During E4, 849-SS-01 and 849-SS-06 had ND RLs greater than the screening level for EDB ($6.6 \mu\text{g}/\text{m}^3$). Sub-slab soil gas results at the same locations for E2 and E3 were ND with RLs below the screening level. As a result, no further ND RL evaluation is necessary for EDB as it had a 0% detection frequency for all sampling events and all ND RLs met the screening level during at least one event (E2).

WEIGHT-OF-EVIDENCE SUMMARY

Building 849 was confirmed as a VI Path Forward Group 2 building due to its potential for VI based on a single sub-slab soil gas exceedance of the draft project-specific RIASL₁₂ for ethylbenzene. However, after further investigation and evaluation, the following evidence supports the conclusion that VI is insignificant at Building 849:

- No exceedances of draft project-specific screening levels in indoor air.
- No additional exceedances of the sub-slab soil gas screening level for ethylbenzene after the initial sampling event.
- No exceedances of TSRIASL₁₂ in sub-slab soil gas.
- The sub-slab soil gas data do not show any strong time dependence nor do the data show any strong seasonal effects.
- As the indoor air exhibits less variability temporally indicates seasonal fluctuations are not expected/were not missed with this evaluation.
- The data do not support the hypothesis that wintertime should have the highest indoor air impacts. The highest sub-slab soil gas concentrations generally were measured in the spring. Similarly, the highest indoor air concentrations were measured in the summer.

- The indoor air data show relatively little spatial variability, despite the somewhat greater spatial variability in the sub-slab soil gas values. This evaluation confirms that the sub-slab soil gas and indoor air concentrations were reasonably consistent from season to season.
- The building is a warehouse with small office set-up, and the occupants are only present sporadically throughout the shift (e.g., anywhere from 2-4 hours depending on duties). Therefore, typical parameters for non-residential exposures may overestimate time spent on duty in this building (i.e., 40 hours/week, 50 weeks/year exposure).

Based on the CSM for Building 849, VI is an insignificant exposure pathway for current building utilization.

PATH FORWARD

Based on the evaluation of the four seasonal confirmation sampling events, the VI pathway continues to be insignificant for Building 849 and the sub-slab soil gas results have demonstrated relatively stable concentrations and no evidence of increasing over time. Sufficient information exists to make a human exposure under control EI determination. However, while currently there is no evidence of potential VI, for future use, LTM is warranted and the building-specific Interim Monitoring Plan is discussed below.

Building-specific Interim Monitoring Plan

Dow will implement an interim monitoring plan at Building 849 until a revised program or more permanent corrective action plan is developed for the site. Interim monitoring will be semi-annual and will begin in Summer 2020.

Indoor air will be monitored at location 849-IA-01. This location was selected for continued monitoring since it demonstrated the highest sub-slab soil gas results. Monitoring will be performed for ethylbenzene. An outdoor air sample will also be collected at the time of each monitoring event. Interim monitoring will be performed semi-annually for a minimum of two years and monitoring results will undergo trend analysis. If results continue to be consistent and below screening levels, monitoring will be conducted on an annual basis. If indoor air results are observed to be increasing, further evaluation will be performed, which may include collection of a sub-slab soil gas sample(s) and an increase in monitoring frequency. Results from each monitoring event will be reported in the annual CAIP. In the event an indoor air result(s) exceeds screening levels, EGLE will be provided a brief email notification. A collocated indoor air and sub-slab soil gas sample will be collected from that location within 45 days. If both sub-slab soil gas and indoor air results indicate that VI continues to be insignificant, monitoring will continue at an appropriate frequency. If both sub-slab soil gas and indoor air results indicate that VI is significant and confirm Group 4 conditions, the building will be moved to Group 4 for follow-up actions.

Dow may propose changes to the frequency or other aspects of this interim monitoring plan in the future based on an evaluation of the data, changes in building use or implementation of other corrective actions to address the potential VI pathway.

5.3.10 VI Seasonal Confirmation Sampling Results Evaluation for Building 858

INTRODUCTION

Building 858 is a Category 2 building located in the central portion of the facility designated as Zone 2 (Figure 5.3.10-1). It is known as the Dursban Production Building and is multiple stories tall. The initial evaluation in the 2017 CAIP concluded that based on the indoor air results, the VI pathway at Building 858 is an insignificant exposure pathway based on current use. However, after the 2018 rescreen effort, Building 858 was placed in VI Path Forward Building Group 4A. Group 4A is a designation for buildings that have sub-slab soil gas and indoor air exceedances that indicate that there is a lack of correlated sample exceedances and other lines of evidence indicate that VI is insignificant and IA exceedances are

likely due to routine workplace chemical use. Seasonal confirmation sampling was implemented to assess potential seasonal variation.

The results of the initial sampling event (E1) were evaluated in the 2017 CAIP. Two additional seasonal events (E2 & E3) were completed and evaluated in Section 5.2.11 of the 2018 CAIP. The results of all completed seasonal events, including E4 from fall 2018, are included in this evaluation.

Building 858	
Initial Sampling Event	Completed
E1	April 2017 (Spring)
Seasonal Sampling Event	Completed
E2	February 2018 (Winter)
E3	July/August 2018 (Summer)
E4	October 2018 (Fall)

Based on the evaluation of the four seasonal confirmation sampling events, the VI pathway continues to be insignificant. Sufficient information exists to make a human exposure under control EI determination.

SUB-SLAB SOIL GAS RESULTS EVALUATION

Sub-slab soil gas samples were collected from six locations from within the building. Indoor air samples were collected at six locations corresponding to the soil gas sample locations, along with an outdoor air sample from the main air intake. The sampling locations are shown on Figure 5.3.10-2. Summary statistics and screening comparison results are presented for sub-slab soil gas on Table 5.3.10-A and indoor and outdoor air on Table 5.3.10-B. The analytical data is presented in Appendix A. Field sampling forms are provided in Appendix B. Table 858-1 presents the sub-slab soil gas results from seasonal confirmation sampling that exceed the draft project-specific screening levels.

Table 858-1. Summary of Sub-Slab Soil Gas Exceedances for Building 858

Analyte (Sampling Event)	Detection Frequency	Measured Range of Detects ($\mu\text{g}/\text{m}^3$)	% Detections > Screening Level	Screening Level* ($\mu\text{g}/\text{m}^3$)
1,2-Dichloropropane (1)	17%	1300	17%	410
1,2-Dichloropropane (2)	0%	ND	0%	410
1,2-Dichloropropane (3)	0%	ND	0%	410
1,2-Dichloropropane (4)	0%	ND	0%	410
Benzene (1)	67%	4.4 - 15,000	33%	510
Benzene (2)	50%	4.6 - 33,000	33%	510
Benzene (3)	50%	2.6 - 6,600	17%	510
Benzene (4)	50%	5.8 - 6,800	33%	510
CFC-12 (1)	100%	48 - 660,000	50%	34,000
CFC-12 (2)	100%	32 - 2,700,000	50%	34,000
CFC-12 (3)	100%	31 - 2,300,000	50%	34,000
CFC-12 (4)	100%	43 - 1,600,000	50%	34,000
Chloroform (1)	33%	300 - 1,400	33%	170
Chloroform (2)	33%	290 - 2,700	33%	170
Chloroform (3)	50%	120 - 1,000	17%	170
Chloroform (4)	33%	85 - 770	17%	170
Ethylbenzene (1)	67%	4.7 - 21,000	17%	1,600
Ethylbenzene (2)	33%	470 - 44,000	17%	1,600
Ethylbenzene (3)	33%	3.4 - 170	0%	1,600
Ethylbenzene (4)	33%	4.2 - 640	0%	1,600
Total Xylenes (1)	67%	5.75 - 11,000	0%	22,000
Total Xylenes (2)	50%	8.4 - 34,000	17%	22,000
Total Xylenes (3)	33%	6.4 - 660	0%	22,000
Total Xylenes (4)	67%	5.7 - 5,400	0%	22,000

Table 858-1. Summary of Sub-Slab Soil Gas Exceedances for Building 858 (Continued)

Analyte (Sampling Event)	Detection Frequency	Measured Range of Detects ($\mu\text{g}/\text{m}^3$)	% Detections > Screening Level	Screening Level* ($\mu\text{g}/\text{m}^3$)
Vinyl Chloride (1)	17%	750	0%	910
Vinyl Chloride (2)	17%	720	0%	910
Vinyl Chloride (3)	17%	1,000	17%	910
Vinyl Chloride (4)	17%	1,000	17%	910

*Screening level provided is the draft project-specific RIASL₁₂.

Table 858-2 summarizes the indoor air results relative to the sub-slab soil gas exceedances, since VI only potentially occurs if the analyte is present in both sub-slab soil gas and indoor air. Therefore, the table below provides the analyte detected above applicable screening levels in sub-slab soil gas as well as the corresponding indoor air sample result. The outdoor air sample result is also provided to determine if the analytes were present in indoor air due to migration from outdoor air.

Table 858-2. Vapor Intrusion Evaluation for Building 858

Analyte	Indoor Air Detection Frequency	Indoor Air Measured Range ($\mu\text{g}/\text{m}^3$)	Indoor Air Screening Level* ($\mu\text{g}/\text{m}^3$)	Outdoor Air Result ($\mu\text{g}/\text{m}^3$)
1,2-Dichloropropane (1)	0%	ND	12.2	ND
1,2-Dichloropropane (2)	0%	ND	12.2	ND
1,2-Dichloropropane (3)	0%	ND	12.2	ND
1,2-Dichloropropane (4)	0%	ND	12.2	ND
Benzene (1)	100%	0.68 - 1.5	15.4	0.54
Benzene (2)	100%	0.69 - 0.96	15.4	0.72
Benzene (3)	100%	0.44 - 0.49	15.4	0.37
Benzene (4)	100%	0.82 - 1.3	15.4	1.2
CFC-12 (1)	100%	3.4 - 5.3	1,020	2
CFC-12 (2)	100%	3.6 - 9.5	1,020	2.4
CFC-12 (3)	100%	4.1 - 7.0	1,020	2.3
CFC-12 (4)	100%	2.9 - 7.2	1,020	1.7
Chloroform (1)	100%	1 - 5.3	5.2	ND
Chloroform (2)	100%	1.8 - 16	5.2	8.6
Chloroform (3)	100%	4.3 - 19	5.2	1.7
Chloroform (4)	100%	0.79 - 3	5.2	6.1
Ethylbenzene (1)	100%	0.2 - 1.3	48	ND
Ethylbenzene (2)	100%	0.31 - 1.8	48	0.95
Ethylbenzene (3)	100%	0.49 - 0.62	48	0.46
Ethylbenzene (4)	100%	0.36 - 0.89	48	1.8
Total Xylenes (1)	100%	0.74 - 6.8	680	ND
Total Xylenes (2)	100%	1.79 - 3.09	680	1.34
Total Xylenes (3)	100%	1.96 - 2.76	680	1.53
Total Xylenes (4)	100%	1.29 - 3.6	680	2.28
Vinyl Chloride (1)	0%	ND	28	ND
Vinyl Chloride (2)	0%	ND	28	ND
Vinyl Chloride (3)	0%	ND	28	ND
Vinyl Chloride (4)	100%	0.044 - 0.054	28	ND

*Screening level provided is the draft project-specific RIASL₁₂.

All indoor air results for Building 858 are below screening levels, with the exception of chloroform. Chloroform in E1 only slightly exceeded the indoor air screening level in a single sample ($5.3 \mu\text{g}/\text{m}^3$ versus a screening level of $5.2 \mu\text{g}/\text{m}^3$). E2 and E3 saw two sample locations with exceedances (sample locations 858-IA-01 and 858-IA-02 in E2; sample locations 858-IA-03 and 858-IA-04 in E3); however, all indoor air chloroform results were below the screening level during E4. Chloroform exceeds screening

levels in sub-slab soil gas at sample location 858-SS-01 during all four events and also location 858-SS-02 during E1 and E2. Figure 858-1 shows the chloroform results for each event at each sample location.

Chloroform is ubiquitous in indoor air and often found in soil gas samples. Chloroform is one of the trihalomethanes produced by chlorination of water supplies. It has long been known that chloroform and other VOCs in tap water can be emitted into indoor air (McKone, 1987).

Further investigation activities were conducted in October 2019 using real-time measurement devices to identify potential pathways for vapor intrusion. Findings were reported to EGLE in the January 2020 Summary of Investigative Findings (see Appendix C). The goal of the building-specific investigation for Building 858 was to identify potential sources and achieve better spatial resolution of chloroform concentrations in the indoor air.

During these activities, potential workplace indoor air sources and various potential preferential pathways were investigated. The laboratory and process area in the building were ruled out as the source of the chloroform in indoor air; however, samples collected in the hallway outside the men's locker room had consistently elevated chloroform concentrations. A drinking water fountain is located in the same hallway that appeared to be malfunctioning, as the water was continuously flowing even when the fountain was not in use. An elevated chloroform concentration of 0.70 ppbv/3.43 $\mu\text{g}/\text{m}^3$ was measured in the hallway but a higher concentration was measured directly at the drinking water fountain itself (1.19 ppbv/5.83 $\mu\text{g}/\text{m}^3$); however, chloroform concentrations were much lower than those measured on October 10, 2019, suggesting there was some significant day-to-day variability in the Building 858 chloroform concentrations.

The drinking water fountain and immediate areas were further investigated and findings showed that the highest concentration, 1.46 ppbv/7.15 $\mu\text{g}/\text{m}^3$, was measured in the sample collected just inches from the running water. These results indicate that the drinking water fountain could be the source of chloroform since chloroform is a byproduct in the chlorination process of drinking water and is known to off-gas from running treated water.

In order to investigate the drinking water itself, a water sample from the drinking water fountain was collected in a one-gallon plastic sampling jug and allowed to sit until it reached room temperature. A small headspace sample collected from the jug yielded a chloroform concentration of 893 ppbv/4,376 $\mu\text{g}/\text{m}^3$. A 'blank' headspace sample was similarly collected from an empty jug, which yielded a 0.63 ppbv/3.09 $\mu\text{g}/\text{m}^3$ concentration. These results suggest that the drinking water is significantly off-gassing chloroform into Building 858.

On the final day of sampling, an experiment was performed using the showers in the MLR. Hot water is expected to off-gas chloroform at a higher rate than cold drinking water; therefore, samples were collected in/near the MLR before and after running all three showers for approximately 15 minutes. The chloroform concentration measured at Site 858-08 in the MLR rose from 0.32 ppbv (1.57 $\mu\text{g}/\text{m}^3$) before running the hot shower water to 8.72 ppbv (42.7 $\mu\text{g}/\text{m}^3$) after. A sample collected in the hallway adjacent to the men's locker room demonstrated a similar increase. A sample collected within one foot of the running shower water (Site 858-Shower) yielded the highest concentration of 15.54 ppbv (76.1 $\mu\text{g}/\text{m}^3$). Finally, a headspace sample from the shower water was analyzed, following the same method as the drinking fountain water sample, and yielded a result of 703 ppbv (3,445 $\mu\text{g}/\text{m}^3$) chloroform.

It was determined that the source of elevated chloroform concentrations is not attributable to VI, but rather it is due to off-gassing from running water within the building. Additionally, the day-to-day variability in chloroform concentrations seen in the building is likely associated with days where shower usage is significant. The water used for both the drinking water fountain and the showers in the men's locker room is treated city water. Running water from a malfunctioning drinking fountain, as well as the showers in the men's locker room, appear to be the main sources of chloroform.

VAPOR INTRUSION CONCEPTUAL SITE MODEL

VI is an exposure pathway that involves the migration of volatilized chemicals from the subsurface to indoor air in overlying, occupied buildings. A source, migration route and a human receptor must be present for the VI pathway to be complete. The focus of this building specific investigation is to evaluate the potential VI exposure pathway for Dow employees and contractors at Building 858. The CSM is illustrated in Figure 5.3.10-3.

Building 858 is a Category 2 building in Zone 2. This building is a manufacturing building with process, laboratory, and shop areas, in addition to office space, a kitchen, library and a locker room. It is known as Dursban Production and is located within the central portion of the facility designated as Zone 2. The building is multiple stories tall but the office space is on the first floor. It is approximately 14,910 ft² (1,385 m²).

The building has central air conditioning with three units. The air intakes for all three units are located on the roof and one chiller is on the west side of the building. There are a total of three bay doors in the process and shop portions of the building that may be left open all day during the summer months. The land surrounding the building is a combination of asphalt and gravel.

Approximately 20 to 30 occupants work in Building 858, including office and operations staff. Operations staff are in the building 24 hours per day, seven days a week, working three eight-hour shifts. The office staff work Monday through Friday, 8am to 5pm or 6am to 3pm. The typical parameters for non-residential exposures are assumed to apply to workers at this building (i.e., 40 hours/week, 50 weeks/year exposure).

A building survey was performed on February 27, 2017. Drains and other openings were screened with a PID and no soil gas entry points were identified (no detections indicated). A chemical inventory was completed during the building survey that identified cleaners, lubricants, rust breakers, and spray paints.

EVALUATION OF SEASONAL CONFIRMATION SAMPLING EVENTS

Four seasonal sampling events have been completed at Building 969. The sampling events encompass more than one year of time and include sampling during each season of the year. The results from the four seasonal confirmation sampling events were evaluated with respect to spatial variability, temporal variability, and seasonal trend analysis.

Building specific attenuation factors (α) were calculated and compared between events to evaluate temporal variability and determine the best estimate of a building-specific attenuation factor. This evaluation serves to confirm that the existing study design is appropriate, and also provides insight for the determination of the path forward for this building.

This evaluation focused on any analytes detected in the sub-slab soil gas samples that met the criterion for inclusion in one or more of the following categories:

- a) Analytes detected in sub-slab soil gas at concentrations that exceeded draft project-specific screening levels;
- b) Analytes detected in sub-slab soil gas at concentrations of 1,000 $\mu\text{g}/\text{m}^3$ or greater in one or more samples. Data for analytes detected above 1,000 $\mu\text{g}/\text{m}^3$ should provide the clearest signal and be the simplest to interpret when assessing data trends. The same data trends observed for these analytes are expected to apply to other similar analytes present at lower concentrations; and
- c) PCE and TCE. These two analytes are of particular interest for many VI evaluations at industrial sites.

For this building, the analytes detected in the sub-slab soil gas at concentrations above the draft project-specific screening levels were the following seven analytes: 1,2-DCP, benzene, CFC-12, chloroform, ethylbenzene, total xylenes, and vinyl chloride. Seven other analytes of potential interest were detected at concentrations $\geq 1,000 \mu\text{g}/\text{m}^3$ in sub-slab soil gas: 4-ethyltoluene, cyclohexane, heptane, hexane, methylene chloride, toluene and trans-1,2-dichloroethene (trans-1,2-DCE); however, five of the seven analytes are not included in this evaluation due to their low detection frequency. PCE and TCE also had very low detection frequencies and very low detected results and were excluded from this evaluation. Hexane and toluene are included for evaluation. Sample results for the analytes included in this evaluation are provided in the data tables below:

Summary of Results for 1,2-Dichloropropane

Sample Type	Sample ID	Measured Concentration ($\mu\text{g}/\text{m}^3$)			
		Apr. 2017	Feb. 2018	Jul./Aug. 2018	Oct. 2018
		E1	E2	E3	E4
Outdoor Air	858-OA-01	<0.75	<0.74	<0.81	<0.74
	858-OA-02	<0.69	<0.75	<0.78	<0.75
Indoor Air	858-IA-01	<0.77	<0.79	<0.73	<0.76
	858-IA-02	<0.71	<0.82	<0.76	<0.73
	858-IA-03	<0.79	<0.84	<0.73	<0.73
	858-IA-04	<0.74	<0.80	<0.73	<0.77
	858-IA-05	<0.76	<0.83	<1.3	<0.74
	858-IA-06	<0.75	<0.79	<0.74	<0.79
Sub-Slab Soil Gas	858-SS-01	<3.7	<9.5	<3.4	<3.6
	858-SS-02	<4	<3.8	<3.5	<3.8
	858-SS-03	<3,600	<16,000	<14,000	<7,600
	858-SS-04	<3,600	<7,400	<7,000	<7,500
	858-SS-05	<3,800	<4,700	<7,400	<3,800
	858-SS-06	1,300	<40	<69	<72

Screening level for indoor air is $12.2 \mu\text{g}/\text{m}^3$ (RIASL₁₂)

Screening level for soil-gas is $410 \mu\text{g}/\text{m}^3$ (RIASL₁₂)

Summary of Results for Benzene

Sample Type	Sample ID	Measured Concentration ($\mu\text{g}/\text{m}^3$)			
		Apr. 2017	Feb. 2018	Jul./Aug. 2018	Oct. 2018
		E1	E2	E3	E4
Outdoor Air	858-OA-01	0.54	0.72	0.37	0.84
	858-OA-02	<0.48	0.61	0.32	1.2
Indoor Air	858-IA-01	0.73	0.96	0.49	1.1
	858-IA-02	1.5	0.96	0.48	1.1
	858-IA-03	0.69	0.78	0.44	0.97
	858-IA-04	0.68	0.89	0.47	1.3
	858-IA-05	0.74	0.84	0.47	0.82
	858-IA-06	0.72	0.69	0.45	0.98
Sub-Slab Soil Gas	858-SS-01	4.4	<6.5	2.6	<2.5
	858-SS-02	13	4.6	3.8	5.8
	858-SS-03	<2,500	<11,000	<9,400	<5,300
	858-SS-04	<2,500	<5,100	<4,800	<5,200
	858-SS-05	15,000	33,000	<5,100	6,800
	858-SS-06	5,800	5,900	6,600	5,800

Screening levels for indoor air are $15.4 \mu\text{g}/\text{m}^3$ (RIASL₁₂) and $54 \mu\text{g}/\text{m}^3$ (TSRIASL₁₂)

Screening levels for soil-gas are $510 \mu\text{g}/\text{m}^3$ (RIASL₁₂) and $1,800 \mu\text{g}/\text{m}^3$ (TSRIASL₁₂)

	RIASL12 Exceedance
	TSRIASL12 Exceedance

Summary of Results for Chlorofluorocarbon (CFC-12)

Sample Type	Sample ID	Measured Concentration ($\mu\text{g}/\text{m}^3$)			
		Apr. 2017	Feb. 2018	Jul./Aug. 2018	Oct. 2018
		E1	E2	E3	E4
Outdoor Air	858-OA-01	2	2.4	2.2	1.7
	858-OA-02	2	2.4	2.3	1.7
Indoor Air	858-IA-01	3.4	3.6	4.8	2.9
	858-IA-02	3.4	3.9	5.1	3.4
	858-IA-03	4.2	8.6	5.5	6
	858-IA-04	4.9	9.1	5.9	4.5
	858-IA-05	5.3	9.5	7	7.2
	858-IA-06	3.8	4.6	4.1	3.1
Sub-Slab Soil Gas	858-SS-01	48	32	31	81
	858-SS-02	62	52	34	43
	858-SS-03	660,000	2,700,000	2,300,000	880,000
	858-SS-04	380,000	1,400,000	980,000	1,600,000
	858-SS-05	540,000	750,000	1,000,000	770,000
	858-SS-06	2,200	3,000	3,700	3,500

Screening levels for indoor air are 1,020 $\mu\text{g}/\text{m}^3$ (RIASL₁₂)Screening levels for soil gas are 34,000 $\mu\text{g}/\text{m}^3$ (RIASL₁₂)**Summary of Results for Chloroform**

Sample Type	Sample ID	Measured Concentration ($\mu\text{g}/\text{m}^3$)			
		Apr. 2017	Feb. 2018	Jul./Aug. 2018	Oct. 2018
		E1	E2	E3	E4
Outdoor Air	858-OA-01	<0.16	8.6	1.7	0.47
	858-OA-02	<0.14	0.42	0.94	6.1
Indoor Air	858-IA-01	1.1	15	4.3	3
	858-IA-02	1.2	16	5	1.7
	858-IA-03	1.7	2	6.2	1.2
	858-IA-04	5.3	3.1	19	1.5
	858-IA-05	1	1.8	4.4	0.79
	858-IA-06	2.3	2.4	5.1	1.4
Sub-Slab Soil Gas	858-SS-01	1,400	2,700	1,000	770
	858-SS-02	300	290	230	85
	858-SS-03	<3,800	<17,000	<14,000	<8,000
	858-SS-04	<3,800	<7,900	<7,400	<7,900
	858-SS-05	<4,000	<5,000	<7,900	<4,000
	858-SS-06	<75	<42	130	<76

Screening levels for indoor air are 5.2 $\mu\text{g}/\text{m}^3$ (RIASL₁₂) and 52 $\mu\text{g}/\text{m}^3$ (TSRIASL₁₂)
Screening levels for soil-gas are 170 $\mu\text{g}/\text{m}^3$ (RIASL₁₂) and 1,700 $\mu\text{g}/\text{m}^3$ (TSRIASL₁₂)

	RIASL ₁₂ Exceedance
	TSRIASL ₁₂ Exceedance

Summary of Results for Ethylbenzene

Sample Type	Sample ID	Measured Concentration ($\mu\text{g}/\text{m}^3$)			
		Apr. 2017	Feb. 2018	Jul./Aug. 2018	Oct. 2018
		E1	E2	E3	E4
Outdoor Air	858-OA-01	<0.14	0.95	0.46	0.31
	858-OA-02	<0.13	0.29	0.22	1.8
Indoor Air	858-IA-01	0.28	1.8	0.62	0.84
	858-IA-02	1.3	1.8	0.6	0.89
	858-IA-03	0.2	0.34	0.59	0.43
	858-IA-04	0.22	0.5	0.62	0.37
	858-IA-05	0.24	0.39	0.49	0.4
	858-IA-06	0.23	0.31	0.56	0.36
Sub-Slab Soil Gas	858-SS-01	4.7	<8.9	3.4	<3.4
	858-SS-02	8.8	<3.6	<3.3	4.2
	858-SS-03	<3,400	<16,000	<13,000	<7,200
	858-SS-04	<3,400	<7,000	<6,600	<7,000
	858-SS-05	21,000	44,000	<7,000	<3,600
	858-SS-06	420	470	170	640

Screening levels for indoor air are 48 $\mu\text{g}/\text{m}^3$ (RIASL₁₂) and 480 $\mu\text{g}/\text{m}^3$ (TSRIASL₁₂)
Screening levels for soil-gas are 170 $\mu\text{g}/\text{m}^3$ (RIASL₁₂) and 1,700 $\mu\text{g}/\text{m}^3$ (TSRIASL₁₂)

Summary of Results for Total Xylenes

Sample Type	Sample ID	Measured Concentration ($\mu\text{g}/\text{m}^3$)			
		Apr. 2017	Feb. 2018	Jul./Aug. 2018	Oct. 2018
		E1	E2	E3	E4
Outdoor Air	858-OA-01	<0.42	<0.42	<0.45	<0.42
	858-OA-02	<0.39	<0.42	<0.45	<0.42
Indoor Air	858-IA-01	0.74	1.79	2.76	1.93
	858-IA-02	5	1.8	2.54	3.6
	858-IA-03	0.77	2.02	2.33	1.64
	858-IA-04	0.82	3.09	2.59	1.4
	858-IA-05	0.93	2.3	1.96	1.68
	858-IA-06	0.92	1.87	2.34	1.29
Sub-Slab Soil Gas	858-SS-01	4	<17.8	4.8	4
	858-SS-02	11.3	8.4	<6.6	22
	858-SS-03	<6,800	<32,000	<26,000	<14,400
	858-SS-04	<6,800	<14,000	<13,200	<14,000
	858-SS-05	9,200	34,000	<14,000	3,600
	858-SS-06	890	430	660	1,060

Screening levels for indoor air are 680 $\mu\text{g}/\text{m}^3$ (RIASL₁₂) and 2,000 $\mu\text{g}/\text{m}^3$ (TSRIASL₁₂)
Screening levels for soil-gas are 22,000 $\mu\text{g}/\text{m}^3$ (RIASL₁₂) and 67,000 $\mu\text{g}/\text{m}^3$ (TSRIASL₁₂)

	RIASL12 Exceedance
	TSRIASL12 Exceedance

Summary of Results for Vinyl Chloride

Sample Type	Sample ID	Measured Concentration ($\mu\text{g}/\text{m}^3$)			
		Apr. 2017	Feb. 2018	Jul./Aug. 2018	Oct. 2018
		E1	E2	E3	E4
Outdoor Air	858-OA-01	<0.042	<0.041	<0.045	0.043
	858-OA-02	<0.038	<0.042	<0.043	0.052
Indoor Air	858-IA-01	<0.042	<0.044	<0.041	0.044
	858-IA-02	<0.039	<0.045	<0.042	0.044
	858-IA-03	<0.044	<0.047	<0.041	0.048
	858-IA-04	<0.041	<0.044	<0.041	0.046
	858-IA-05	<0.042	<0.046	<0.07	0.047
	858-IA-06	<0.041	<0.044	<0.041	0.054
Sub-Slab Soil Gas	858-SS-01	<2	<5.2	<1.9	<38
	858-SS-02	<2.2	<2.1	<1.9	<2
	858-SS-03	<2,000	<9,200	<7,500	<2.1
	858-SS-04	<2,000	<4,100	<3,800	<4,200
	858-SS-05	<2,100	<2,600	<4,100	<4,100
	858-SS-06	750	720	1,000	1,000

Screening levels for indoor air are 28 $\mu\text{g}/\text{m}^3$ (RIASL₁₂) and 280 $\mu\text{g}/\text{m}^3$ (TSRIASL₁₂)
Screening levels for soil-gas are 910 $\mu\text{g}/\text{m}^3$ (RIASL₁₂) and 9,100 $\mu\text{g}/\text{m}^3$ (TSRIASL₁₂)

Summary of Results for Hexane

Sample Type	Sample ID	Measured Concentration ($\mu\text{g}/\text{m}^3$)			
		Apr. 2017	Feb. 2018	Jul./Aug. 2018	Oct. 2018
		E1	E2	E3	E4
Outdoor Air	858-OA-01	<0.57	0.96	<0.62	<0.56
	858-OA-02	<0.52	2.5	0.67	<0.57
Indoor Air	858-IA-01	2.3	6.2	9.5	5.2
	858-IA-02	5.2	5.1	5.7	2.1
	858-IA-03	<0.6	1.2	<0.56	0.92
	858-IA-04	0.78	1.2	0.68	0.65
	858-IA-05	0.86	0.77	<0.97	0.88
	858-IA-06	0.69	1.4	0.59	0.72
Sub-Slab Soil Gas	858-SS-01	8	<7.2	12	<2.7
	858-SS-02	11	<2.9	<2.7	3.6
	858-SS-03	<2800	<13000	<10000	<5800
	858-SS-04	2800	6200	<5300	<5700
	858-SS-05	25000	39000	11000	17000
	858-SS-06	2800	2100	3100	2700

Screening levels for indoor air are 2,200 $\mu\text{g}/\text{m}^3$ (RIASL₁₂)
Screening levels for soil gas are 72,000 $\mu\text{g}/\text{m}^3$ (RIASL₁₂)

	RIASL12 Exceedance
	TSRIASL12 Exceedance

Summary of Results for Toluene

Sample Type	Sample ID	Measured Concentration ($\mu\text{g}/\text{m}^3$)			
		Apr. 2017	Feb. 2018	Jul./Aug. 2018	Oct. 2018
		E1	E2	E3	E4
Outdoor Air	858-OA-01	0.37	1.4	6.8	1.2
	858-OA-02	0.28	2	6.3	1.8
Indoor Air	858-IA-01	0.81	2	6.5	5.2
	858-IA-02	6.5	1.9	6.3	4.4
	858-IA-03	0.94	1.7	6.4	3
	858-IA-04	0.99	2.1	6.8	1.4
	858-IA-05	1.4	1.8	5.2	1.4
	858-IA-06	1.2	1.5	6.6	1.5
Sub-Slab Soil Gas	858-SS-01	26	14	33	<2.9
	858-SS-02	52	22	11	17
	858-SS-03	<3,000	<13,000	<11,000	<6,200
	858-SS-04	<2,900	<6,100	<5,700	<6,100
	858-SS-05	12,000	33,000	<6,100	<3,100
	858-SS-06	2,200	2,400	2,000	2,300

Screening levels for indoor air are $7,500 \mu\text{g}/\text{m}^3$ (RIASL₁₂)

Screening levels for soil gas are $250,000 \mu\text{g}/\text{m}^3$ (RIASL₁₂)

	RIASL12 Exceedance
	TSRIASL12 Exceedance

EVALUATION OF VI DATA TRENDS

Data trends for Building 858 are discussed below for both sub-slab soil gas and indoor air. When data exhibit a narrow range of variability, it is typical practice to express the range as a percentage. When data exhibit a large range of variability, however, it is more useful to express the range in orders of magnitude (i.e., factors of 10). This can be expressed mathematically as the log of the ratio of maximum/minimum values. If the values differ by a factor of 10, the log of the ratio is 1, if the values differ by a factor of 100, the log of the ratio is 2, and so on.

The variability across all locations over all sampling events is the total variability. This encompasses different types of variability, including spatial variability (i.e., how do the results vary from location to location), temporal variability (i.e., how do the results at a given location vary over time), and measurement variability. Measurement variability can be determined by evaluating results of duplicate or collocated samples and includes both sampling variability and analytical variability. The comparison of two data values is typically expressed as a RPD. The comparison of three or more data values is typically expressed as the %CV, which is the standard deviation divided by the mean.

Sub-Slab Soil Gas Data Trends

Spatial Variability of Sub-Slab Soil Gas – The soil gas exhibits up to four orders of magnitude of spatial variability. For example, sub-slab soil gas detections of CFC-12 vary from 43 to 1,600,000 $\mu\text{g}/\text{m}^3$ (log of max./min. = 4.6) across the six locations for E4. During that same sampling event, the range for chloroform was 85 to 770 $\mu\text{g}/\text{m}^3$ (log of max./min. = 0.96) and the range for ethylbenzene was 4 to 680 $\mu\text{g}/\text{m}^3$ (log of max./min. = 2.2).

Temporal Variability of Soil Gas – The soil gas exhibits at most one order of magnitude of temporal variability. For example, sub-slab soil gas concentrations of CFC-12 vary from 380,000 to 1,600,000 $\mu\text{g}/\text{m}^3$ at location 858-SS-04 (log max/min = 0.6) across all four sampling events; however, due to these detected concentrations of CFC-12, many other AOIs were ND at this sample location. At location 858-SS-06, detected concentrations of CFC-12 vary from 2,200 to 3,700 $\mu\text{g}/\text{m}^3$ (log max/min = 0.23). At that

same location, the range for chloroform was 170 to 640 $\mu\text{g}/\text{m}^3$ (log max/min = 0.57). The variability for other analytes was similar and relatively small.

Seasonal Confirmation Sampling Trend Analysis – No formal statistical tests were performed but the sub-slab soil gas data at locations with the highest concentrations do not exhibit any upward or downward trend over the course of the four sampling events. This is illustrated in the graph below, which shows results for several locations with relatively high concentrations for the six analytes detected at the highest concentrations. Note that the y-axis is a log scale.

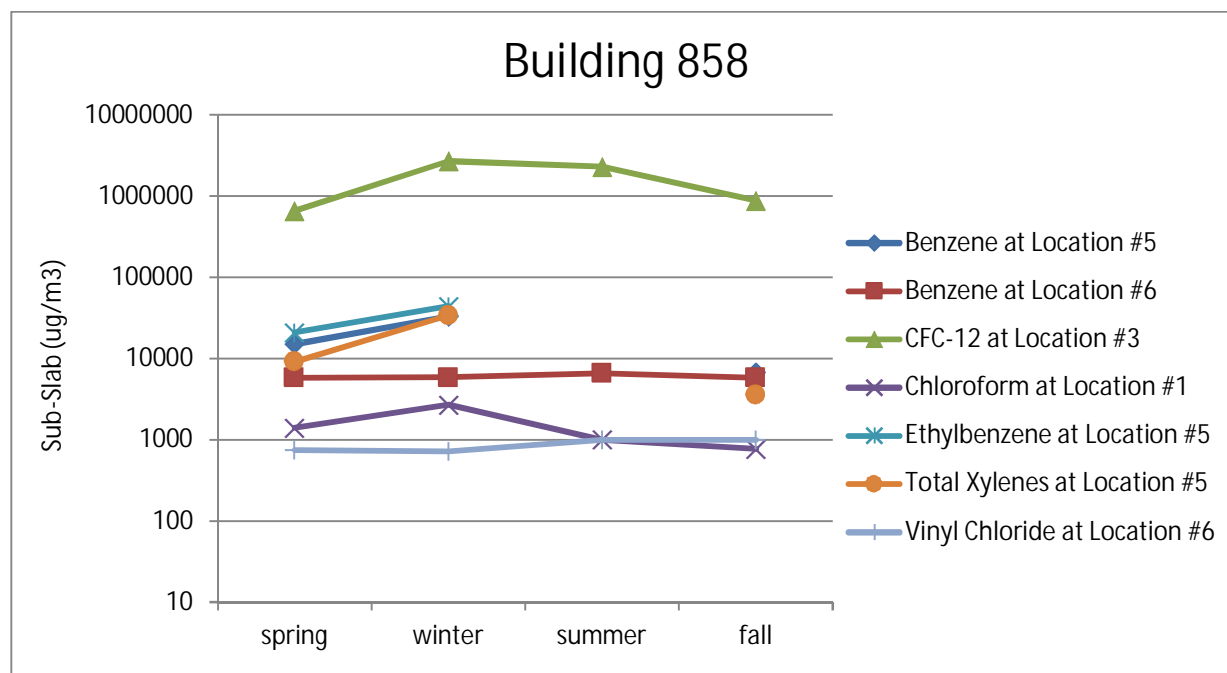

The data set was examined to see what the potential consequences would have been had only a single sampling event been performed. For CFC-12, the highest sub-slab soil gas concentrations occurred in E2 and E3 (winter and summer, respectively). For benzene, total xylenes and ethylbenzene, the highest sub-slab soil gas concentrations were collected during the E1 and E2 (spring and winter, respectively) and the lowest concentrations occurred during the fall (E4). Overall, the minimum and maximum values appear to be consistent between sampling events.

For CFC-12, a concentration of 380,000 $\mu\text{g}/\text{m}^3$ was measured during E1 and the highest concentration (1,600,000 $\mu\text{g}/\text{m}^3$) was measured during E4. If only E1 had been performed, a negative bias of 24% would have been introduced (i.e., the E2 result was 24% higher than the E1 result). For ethylbenzene, the maximum concentration in E1 was 21,000 $\mu\text{g}/\text{m}^3$ and the highest concentration was 44,000 $\mu\text{g}/\text{m}^3$ in E2. If only E1 had been performed, a negative bias of 48% would have been introduced. For benzene, the detection in E1 was 15,000 $\mu\text{g}/\text{m}^3$ and the highest concentration was 33,000 $\mu\text{g}/\text{m}^3$ in E2. If only E1 had been performed, a negative bias of 45% would have been introduced. Therefore, implementing four seasonal confirmation sampling events provided only limited insight regarding maximum concentration levels, but the larger data set served to increase the confidence in the findings including demonstrating the consistency of the maximum reported results.

Indoor Air Data Trends

Spatial Variability of Indoor Air – The indoor air exhibits at most one order of magnitude of spatial variability. For example, chloroform was detected in all four indoor air samples and varied from 2 to 16 $\mu\text{g}/\text{m}^3$ during E2 (log max./min. = 0.95). PCE had a similar amount of spatial variability during E1, E3 and

E4. Ethylbenzene had similar variability to chloroform. CFC-12 was detected in all six indoor air samples and varied from 3.6 to 9.5 $\mu\text{g}/\text{m}^3$ (log max./min. = 0.42.). CFC-12 had less spatial variability during the other sampling events.

Temporal Variability of Indoor Air – The detected values for chloroform, CFC-12, ethylbenzene, total xylenes, and benzene exhibit temporal variability of about one order of magnitude or less over time. For example, chloroform was detected during four sampling events at locations 858-IA-01 through 858-IA-06 and the values ranged from 1.1 to 15 $\mu\text{g}/\text{m}^3$ at location 858-IA-03 (log max./min. = 0.7) and from 1.2 to 6.2 $\mu\text{g}/\text{m}^3$ at location 858-IA-03 (log max./min. = 1.3). Ethylbenzene has similar variability over time. For example, ethylbenzene was detected during all four sampling events at location 680-IA-01, with values ranging from 0.28 to 1.8 $\mu\text{g}/\text{m}^3$ (log max./min. = 0.81).

Additional Analyses

Comparison of Sub-Slab Soil Gas and Indoor Air Data Sets – As expected, the sub-slab soil gas data exhibit greater spatial variability than the indoor air data set. The sub-slab soil gas data had somewhat greater temporal variability than the indoor air data, which is contrary to expectations. This suggests that any indoor emissions of the AOIs do not vary greatly over time if they are in regular use in the building.

Seasonal Effects – The data do not support the hypothesis that wintertime will have higher indoor air impacts. The highest sub-slab soil gas concentrations were measured in February (winter), but the highest indoor air concentrations were generally measured in April (spring), February (winter), and August (summer) depending on the analyte. The data indicate that wintertime “stack effects” across the slab are not significant compared with other seasons of the year.

Comparison of Attenuation Factors by Event – Attenuation factors were calculated for CFC-12 based on maximum values since CFC-12 had 100% detection frequency in both media. However, CFC-12 was detected in outdoor air. Therefore, the indoor air maximum concentration was corrected for contribution of outdoor air to indoor air (e.g., outdoor air detected concentration was subtracted from indoor air concentration). The calculated event-specific attenuation factors are shown in Tables 858-3.

Table 858-3. Comparison of Building-Specific Attenuation Factors for CFC-12 by Event

	E1 (Spring)	E2 (Winter)	E3 (Summer)	E4 (Fall)
Maximum Values				
CFC-12 in Sub-Slab Soil Gas ($\mu\text{g}/\text{m}^3$)	660,000	2,700,000	2,300,000	1,600,000
CFC-12 in Outdoor Air ($\mu\text{g}/\text{m}^3$)	2	2.4	2.3	1.7
CFC-12 in Indoor Air ($\mu\text{g}/\text{m}^3$)	5.3	9.5	7	7.2
CFC-12 in Indoor Air ($\mu\text{g}/\text{m}^3$) Corrected for Outdoor Air	3.3	7.6	4.7	5.5
Attenuation Factor	5.0E-06	2.8E-06	2.0E-06	3.4E-06

These serve as the best estimates of attenuation at this building. The results can vary from day to day due to differences in rates of vapor intrusion and rates of building ventilation. Overall, the most conservative estimate of a building-specific attenuation factor for Building 858 is 5.0E-06 based on CFC-12 during E1.

Temporal Variability in Attenuation Factor – As shown in the table above, there was less than one order of magnitude in temporal variability in the calculated attenuation factors observed in the data set, with E3 having the least attenuation and E1 with the greatest attenuation.

NON-DETECT EVALUATION

Table 858-4 below lists the analytes in sub-slab soil gas that have ND RLs greater than the screening levels. The table also includes the indoor air results for each of the analytes. If a sub-slab soil gas analyte has ND RL exceedances, but all results and ND RLs in indoor air are below the screening levels,

no further evaluation is warranted. If an analyte was identified as an AOI in sub-slab soil gas (detected results > screening level), it is excluded from the ND evaluation (1,2-DCP, benzene, CFC-12, chloroform, ethylbenzene, total xylenes, and vinyl chloride). Also, if an ND analyte has a 0% detection frequency for all sampling events and all ND RLs met the screening level during at least one event, no further ND evaluation is warranted.

Table 858-4. Non-Detect Evaluation for Building 858

Soil Gas Analytes with ND RL > SL	Indoor Air Result Summary
1,1,2,2-Tetrachloroethane	0% Detection Frequency, All ND RLs < RIASL ₁₂
1,1,2-Trichloroethane	0% Detection Frequency, All ND RLs < RIASL ₁₂
1,1-Dichloroethane	0% Detection Frequency, All ND RLs < RIASL ₁₂
1,2,4-Trichlorobenzene	0% Detection Frequency, 83% ND RLs < TSRIASL ₁₂ in E1, E3 and E4
1,2,4-Trimethylbenzene	17%-100% Detection Frequency, All detects and ND RLs < RIASL ₁₂
1,2-Dibromoethane (EDB)	0% Detection Frequency, All ND RLs > RIASL ₁₂
1,2-Dichloroethane	0 - 100% Detection Frequency, All detects and ND RLs < RIASL ₁₂
1,3,5-Trimethylbenzene	0%-33% Detection Frequency, All detects and ND RLs < RIASL ₁₂
1,3-Dichlorobenzene	0% Detection Frequency, All ND RLs < RIASL ₁₂
1,4-Dichlorobenzene	0 - 100% Detection Frequency, All detects and ND RLs < RIASL ₁₂
1,4-Dioxane	0% Detection Frequency, All ND RLs < RIASL ₁₂
2-Hexanone	0% Detection Frequency, All ND RLs < RIASL ₁₂
2-Propanol	83% - 100% Detection Frequency, All detects and ND RLs < RIASL ₁₂
alpha-Chlorotoluene	0% Detection Frequency, All ND RLs < RIASL ₁₂
Bromodichloromethane	0%-17% Detection Frequency, All detects and ND RLs < RIASL ₁₂
Bromoform	0% Detection Frequency, All ND RLs < RIASL ₁₂
Bromomethane	0% Detection Frequency, All ND RLs < RIASL ₁₂ for E1, E2, and E4
Carbon Tetrachloride	100% Detection Frequency, All detects and ND RLs < RIASL ₁₂
Chlorobenzene	0% - 100% Detection Frequency, All detects and ND RLs < RIASL ₁₂
Chloromethane	0%-100% Detection Frequency, All detects and ND RLs < RIASL ₁₂
cis-1,2-Dichloroethene	0% Detection Frequency, All ND RLs < RIASL ₁₂
Cumene	0% Detection Frequency, All ND RLs < RIASL ₁₂
Dibromochloromethane	0% Detection Frequency, All ND RLs < RIASL ₁₂
Dibromomethane	0% Detection Frequency, All ND RLs < RIASL ₁₂
Hexachlorobutadiene	0% Detection Frequency, All ND RLs > RIASL ₁₂
Naphthalene	0%-17% Detection Frequency, All detects and ND RLs < RIASL ₁₂
Styrene	0%-33% Detection Frequency, All detects and ND RLs < RIASL ₁₂
Tetrachloroethene (PCE)	0%-100% Detection Frequency, All detects and ND RLs < RIASL ₁₂
Trichloroethene (TCE)	0%-17% Detection Frequency, All detects and ND RLs < RIASL ₁₂
trans-1,2-DCE	0% Detection Frequency, All ND RLs < RIASL ₁₂

WEIGHT-OF-EVIDENCE SUMMARY

Building 858 was confirmed as a VI Path Forward Group 4A building due to its potential for VI based on sub-slab soil gas exceedances of the draft project-specific RIASL₁₂ and/or TSRIASL₁₂. However, after further investigation and evaluation, the following evidence supports the conclusion that VI is insignificant at Building 858:

- The sub-slab soil gas results indicate that concentrations are stable or decreasing and the sub-slab soil gas data do not show any strong time dependence nor do the data show any strong seasonal effects.
- All indoor air results are less than the draft project-specific screening levels, with the exception of chloroform. Indoor sources were identified during the further investigation completed in October 2019. The maximum detected results of chloroform in indoor air are less than 1% of the Dow OEL.
- Based on the results of the October 2019 further investigation activities, it is likely that the source of chloroform in Building 858 is running water from a malfunctioning drinking water fountain together with the showers from the men's locker room. The source of the water in both locations is treated water from the City of Midland. Chloroform is one of the trihalomethanes produced by chlorination of water supplies. It has long been known that chloroform and other VOCs in tap water can be emitted into indoor air (McKone, 1987).
- The data do not support the hypothesis that wintertime should have the highest indoor air impacts. The sub-slab soil gas concentrations are no higher in winter than during other seasons. The highest indoor air concentrations were measured in the spring and fall.
- The indoor air data show relatively little spatial variability, despite the greater spatial variability in the sub-slab soil gas values. This evaluation confirms that the sub-slab soil gas and indoor air concentrations were relatively constant from season to season.
- As shown in the table below, the building-specific attenuation factor yields estimated indoor air concentrations for EDB and HCBd well below the RIASL₁₂; furthermore, lower reporting limits were achieved for these ND analytes in other events and the analytes remained ND.

Parameters	EDB	HCBd
Building-specific AF	5E-06	5E-06
Maximum reporting limit in SSSG	<28,000	<150,000
Estimated Indoor Air Concentration	0.14	0.75
Indoor Air ND RL	<0.42	<15
Indoor Air RIASL ₁₂	0.2	5.4

Based on the results of the four seasonal confirmation sampling events, the further investigation activities and the CSM for Building 858, VI is an insignificant exposure pathway for current building utilization.

PATH FORWARD

Building 858 is confirmed as a VI Path Forward Group 4A building. Further investigation activities were conducted with a mobile GC in October 2019 and reported in the January 2020 Summary of Investigative Findings (see Appendix G).

During the further investigation activities, potential workplace indoor sources were investigated and the laboratory and process area in the building were ruled out as the source of the chloroform in indoor air. A drinking water fountain, located in the same hallway as the men's locker room, appeared to be malfunctioning, as the water was continuously flowing even when the fountain was not in use. Based on the results of the further investigation activities, it was determined that the source of elevated chloroform concentrations is not attributable to VI, but rather it is due to off-gassing from running water within the building (drinking water fountain and the showers in the men's locker room). Additionally, the day-to-day variability in chloroform concentrations seen in the building is likely associated with days where shower usage is significant. The water used for both the drinking water fountain and the showers in the men's locker room is treated city water. Running water from a malfunctioning drinking fountain, as well as the showers in the men's locker room, appear to be the main sources of chloroform. Chloroform is ubiquitous

in indoor air and often found in soil gas samples. Chloroform is one of the trihalomethanes produced by chlorination of water supplies. It has long been known that chloroform and other VOCs in tap water can be emitted into indoor air (McKone, 1987).

Based on the evaluation of the four seasonal confirmation sampling events, the further investigation activities, and the CSM, the VI pathway continues to be insignificant for Building 858 and the sub-slab soil gas results have demonstrated relatively stable concentrations and no evidence of increasing over time. Sufficient information exists to make a human exposure under control EI determination. However, while currently there is no evidence of potential VI, for future use, LTM is warranted and the implementation of the building-specific Interim Monitoring Plan began in August 2019.

Building-specific Interim Monitoring Plan

Dow presented an interim monitoring plan for Building 858 during the February 2019 Corrective Action status meeting. Indoor air is monitored at location 858-IA-01 and 858-IA-05. These locations were selected for continued monitoring since it demonstrated the highest sub-slab soil gas results. Monitoring is performed for 1,2-DCP, benzene, CFC-12, chloroform, ethyl benzene, total xylenes & vinyl chloride. The indoor air results are shown below:

Indoor Air Analyte	Result Value ($\mu\text{g}/\text{m}^3$)	Reporting Limit ($\mu\text{g}/\text{m}^3$)	EGLE Project- Specific RIASL ₁₂ ($\mu\text{g}/\text{m}^3$)	NONRES TSRIASL ₁₂ ($\mu\text{g}/\text{m}^3$)	Dow IH OEL (8hr Time Weighted Average) ($\mu\text{g}/\text{m}^3$)
<i>Sample 858-IA-01</i>					
1,2-Dichloropropane	ND	0.78	12.2	NA	46,200
Benzene	0.3	0.27	15.4	54	1,595
CFC-12	2.1	0.17	1,020	NA	4,950,000
Chloroform	4.6	0.16	5.2	52	9,760
Ethyl benzene	ND	0.14	48	480	86,800
Total xylenes	0.81	0.43	680	2,000	434,000
Vinyl chloride	ND	0.043	28	280	2,560
<i>Sample 858-IA-05</i>					
1,2-Dichloropropane	ND	0.73	12.2	NA	46,200
Benzene	0.27	0.25	15.4	54	1,595
CFC-12	5.9	0.16	1,020	NA	4,950,000
Chloroform	4.6	0.15	5.2	52	9,760
Ethyl benzene	ND	0.14	48	480	86,800
Total xylenes	0.81	0.41	680	2,000	434,000
Vinyl chloride	ND	0.04	28	280	2,560

As shown on the table above, all indoor air result from the Summer 2019 IM event were less than the indoor air RIASL₁₂ or ND with RLs less than the screening level. The analytical data is presented in Appendix A. Field sampling forms are provided in Appendix B. The next IM event is scheduled for Winter 2019/2020. Semi-annual interim monitoring will continue in the summer and winter of 2020. For future IM events, an outdoor air sample will also be collected at the time of each monitoring event.



Figure 858-1

Chloroform	Soil Gas	Indoor Air
	ug/m ³	ug/m ³
Event 1	1,400	1.1
Event 2	2,700	15
Event 3	1,000	4.3

Chloroform	Soil Gas	Indoor Air
	ug/m ³	ug/m ³
Event 1	ND (1,900)	1.7
Event 2	ND (8,500)	2
Event 3	ND (7,000)	6.2

Chloroform	Soil Gas	Indoor Air
	ug/m ³	ug/m ³
Event 1	ND (2,000)	1
Event 2	ND (2,500)	1.8
Event 3	ND (3,950)	4.4

Chloroform	Soil Gas	Indoor Air
	ug/m ³	ug/m ³
Event 1	300	1.2
Event 2	290	16
Event 3	120	5

Chloroform	Soil Gas	Indoor Air
	ug/m ³	ug/m ³
Event 1	ND (1,900)	5.3
Event 2	ND (3,950)	3.1
Event 3	ND (3,700)	19

Chloroform	Soil Gas	Indoor Air
	ug/m ³	ug/m ³
Event 1	ND (37.5)	2.3
Event 2	ND (21)	2.4
Event 3	ND (130)	5.1

Legend

⊗ 858-## Sub-slab/Indoor Air Location

Exceeds RIASL₁₂ Only

Exceeds TSRIASL₁₂

Exceeds Dow OEL

Media	COC	RIASL ₁₂	TSRIASL ₁₂	OEL
Soil Gas	Chloroform	170	1,700	--
Indoor Air	Chloroform	5.2	52	9,760

858 Building
First Floor

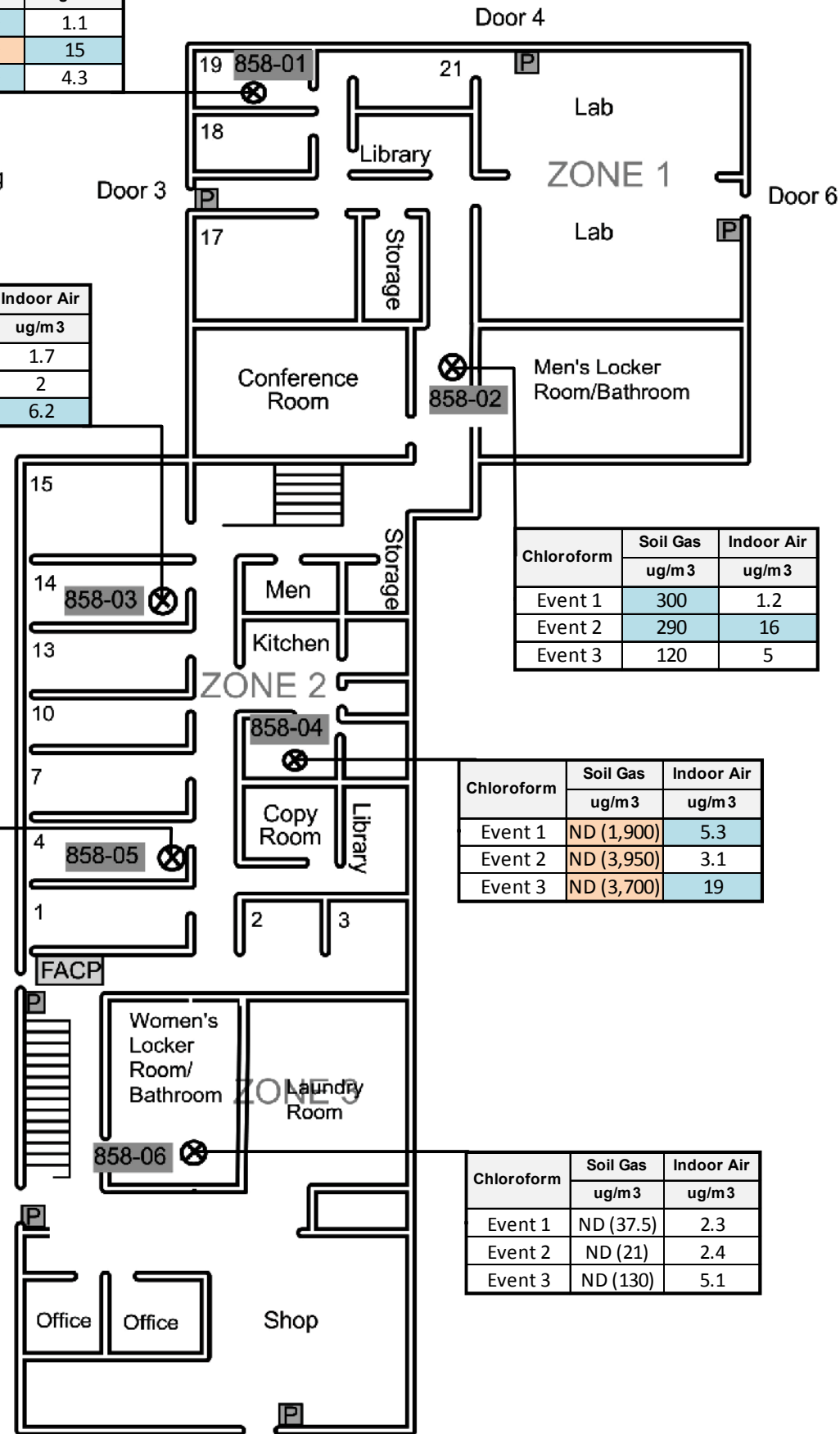

Notes:

All units ug/m³

Initial Sampling Event (1) = April 2017

Seasonal Confirmation Sampling Event 2 = February 2018

Seasonal Confirmation Sampling Event 3 = July 2018

Seasonal Confirmation Sampling Event 4 = April 2018

Building has two different intakes; therefore two outdoor sample locations were collected. One was collected the second story roof above the control room. The second was collected on the first story roof above the E-W hallway near the lab.

Chloroform	Outdoor Air Sample 1 Results
	ug/m ³
Event 1	ND (0.08)
Event 2	8.6
Event 3	1.7

Chloroform	Outdoor Air Sample 2 Results
	ug/m ³
Event 1	ND (0.07)
Event 2	0.42
Event 3	0.94

Sub-slab Soil Gas and Indoor Air Results for Chloroform Zone 2 Phase 1 Sampling Events 1 - 3 Building 858

5.3.11 VI Seasonal Confirmation Sampling Results Evaluation for Building 969

INTRODUCTION

Building 969 is a Category 2 building located in the central portion of the facility designated as Zone 2 (Figure 5.3.11-1). It is known as the Ag Chem Development Building and is multiple stories tall with the office space on the first floor. The initial evaluation in the 2017 CAIP concluded that based on the indoor air results, the VI pathway at Building 969 is an insignificant exposure pathway based on current use. All indoor air analytes were detected below screening levels at Building 969; however, based on the sub-slab soil gas results and given the potential for future VI, Building 969 was placed in VI Path Forward Building Group 2 and seasonal confirmation sampling was conducted.

The results of the initial sampling event (E1) were evaluated in the 2017 CAIP. Since that time, two additional seasonal events (E2 & E3) were completed and evaluated in Section 5.2.12 of the 2018 CAIP. The results of all completed seasonal events, including E4 from fall 2018, are included in this evaluation.

Building 969	
Initial Sampling Event	Completed
E1	April 2017 (Spring)
Seasonal Sampling Event	Completed
E2	February 2018 (Winter)
E3	August 2018 (Summer)
E4	October 2018 (Fall)

Based on the evaluation of the four seasonal confirmation sampling events the VI pathway continues to be insignificant. Sufficient information exists to make a human exposure under control EI determination.

SUB-SLAB SOIL GAS RESULTS EVALUATION

Sub-slab soil gas samples were collected from nine locations from within the building. Indoor air samples were collected at nine locations corresponding to the soil gas sample locations, along with an outdoor air sample from the main air intake. The sampling locations are shown on Figure 5.3.11-2. Summary statistics and screening comparison results are presented for sub-slab soil gas on Table 5.3.11-A and indoor and outdoor air on Table 5.3.11-B. The analytical data is presented in Appendix A. Field sampling forms are provided in Appendix B. Table 969-1 presents the sub-slab soil gas results from seasonal confirmation sampling that exceed the draft project-specific screening levels.

Table 969-1. Summary of Sub-Slab Soil Gas Exceedances for Building 969

Analyte (Sampling Event)	Detection Frequency	Measured Range of Detects ($\mu\text{g}/\text{m}^3$)	% Detections > Screening Level	Screening Level* ($\mu\text{g}/\text{m}^3$)
1,1,2-Trichloroethane (1)	0%	ND	0%	20
1,1,2-Trichloroethane (2)	0%	ND	0%	20
1,1,2-Trichloroethane (3)	0%	ND	0%	20
1,1,2-Trichloroethane (4)	11%	4,500	11%	20
1,2,4-Trimethylbenzene (1)	67%	11 - 200	0%	6,100
1,2,4-Trimethylbenzene (2)	67%	3.8 - 450	0%	6,100
1,2,4-Trimethylbenzene (3)	78%	8.9 - 8,300	11%	6,100
1,2,4-Trimethylbenzene (4)	44%	200 - 5,200	0%	6,100
Benzene (1)	100%	3.6 - 3,800	11%	510
Benzene (2)	67%	6.5 - 1,300	11%	510
Benzene (3)	89%	3.9 - 15,000	44%	510
Benzene (4)	44%	220 - 2,000	33%	510

Table 969-1. Summary of Sub-Slab Soil Gas Exceedances for Building 969 (Continued)

Analyte (Sampling Event)	Detection Frequency	Measured Range of Detects ($\mu\text{g}/\text{m}^3$)	% Detections > Screening Level	Screening Level* ($\mu\text{g}/\text{m}^3$)
Cumene (1)	44%	7.9 - 330	0%	380
Cumene (2)	44%	16 - 52	0%	380
Cumene (3)	56%	32 - 1,300	11%	380
Cumene (4)	44%	62 - 720	11%	380
Ethylbenzene (1)	100%	15 - 12,000	11%	1,600
Ethylbenzene (2)	100%	5.7 - 1,500	0%	1,600
Ethylbenzene (3)	100%	9.8 - 12,000	33%	1,600
Ethylbenzene (4)	67%	4.3 - 7,200	33%	1,600
Naphthalene (1)	56%	42 - 570	33%	120
Naphthalene (2)	33%	21 - 510	22%	120
Naphthalene (3)	44%	130 - 3,100	44%	120
Naphthalene (4)	22%	360 - 820	22%	120
Total Xylenes (1)	100%	49 - 42,800	11%	22,000
Total Xylenes (2)	100%	14.7 - 5,600	0%	22,000
Total Xylenes (3)	89%	37.9 - 34,000	11%	22,000
Total Xylenes (4)	89%	8.85 - 34,000	11%	22,000

Table 969-2 summarizes the indoor air results relative to the sub-slab soil gas exceedances, since VI only potentially occurs if the analyte is present in both sub-slab soil gas and indoor air. Therefore, the table below provides the analyte detected above applicable screening levels in sub-slab soil gas as well as the corresponding indoor air sample result. The outdoor air sample result is also provided to determine if the analytes were present in indoor air due to migration from outdoor air.

Table 969-2. Vapor Intrusion Evaluation for Building 969

Analyte	Indoor Air Detection Frequency	Indoor Air Measured Range ($\mu\text{g}/\text{m}^3$)	Indoor Air Screening Level* ($\mu\text{g}/\text{m}^3$)	Outdoor Air Result ($\mu\text{g}/\text{m}^3$)
1,1,2-Trichloroethane (1)	0%	ND	0.62	ND
1,1,2-Trichloroethane (2)	0%	ND	0.62	ND
1,1,2-Trichloroethane (3)	0%	ND	0.62	ND
1,1,2-Trichloroethane (4)	0%	ND	0.62	ND
1,2,4-Trimethylbenzene (1)	11%	1.3	184	ND
1,2,4-Trimethylbenzene (2)	0%	ND	184	ND
1,2,4-Trimethylbenzene (3)	22%	1.5 - 3.5	184	ND
1,2,4-Trimethylbenzene (4)	0%	ND	184	ND
Benzene (1)	100%	0.55 - 1.3	15.4	0.6
Benzene (2)	67%	0.32 - 0.43	15.4	0.41
Benzene (3)	67%	0.33 - 0.40	15.4	0.31
Benzene (4)	100%	0.32 - 1.1	15.4	0.33
Cumene (1)	0%	ND	11.4	ND
Cumene (2)	0%	ND	11.4	ND
Cumene (3)	0%	ND	11.4	ND
Cumene (4)	0%	ND	11.4	ND
Ethylbenzene (1)	100%	0.77 - 3.3	48	0.64
Ethylbenzene (2)	89%	0.23 - 2.7	48	0.22
Ethylbenzene (3)	100%	0.46 - 6.0	48	0.27
Ethylbenzene (4)	100%	0.16 - 3.9	48	0.29
Naphthalene (1)	0%	ND	3.6	ND
Naphthalene (2)	0%	ND	3.6	ND
Naphthalene (3)	22%	1.3 - 2.3	3.6	ND
Naphthalene (4)	22%	0.5 - 9.1	3.6	ND

Table 969-2. Vapor Intrusion Evaluation for Building 969 (Continued)

Analyte	Indoor Air Detection Frequency	Indoor Air Measured Range ($\mu\text{g}/\text{m}^3$)	Indoor Air Screening Level* ($\mu\text{g}/\text{m}^3$)	Outdoor Air Result ($\mu\text{g}/\text{m}^3$)
Total Xylenes (1)	100%	2.78 - 11.7	680	2.02
Total Xylenes (2)	100%	0.525 - 9.7	680	0.45
Total Xylenes (3)	100%	1.9 - 24.4	680	1.1
Total Xylenes (4)	100%	0.64 - 15.6	680	1.06

All indoor air results for Building 969, with the exception of a single result for naphthalene in E4, are below screening levels. Naphthalene had a single exceedance of the indoor air RIASL_{12} ($9.1 \mu\text{g}/\text{m}^3$ vs $3.6 \text{ mg}/\text{u}3$) at location 969-IA-05 during E4. Naphthalene had no other indoor exceedances throughout all of the other seasonal confirmation sampling events. Furthermore, the sub-slab soil gas result at 969-SS-05 was ND ($<79 \mu\text{g}/\text{m}^3$) and the ND RL was well below the RIASL_{12} of $120 \mu\text{g}/\text{m}^3$.

Two additional analytes were detected in indoor air throughout seasonal confirmation sampling and are not attributable to VI. TCE was detected ($5.3 \mu\text{g}/\text{m}^3$) in indoor air above the RIASL_{12} ($4 \mu\text{g}/\text{m}^3$) during E4 at location 969-IA-01; however, all sub-slab soil gas results for TCE at Building 969 are less than the RIASL_{12} . Chloroform was detected above the indoor air RIASL_{12} during E3 in locations 969-IA-05 through 969-IA-09; however, all sub-slab soil gas results for chloroform at Building 969 are less than the RIASL_{12} . These analytes are likely present in indoor air due to active workplace chemical use.

VAPOR INTRUSION CONCEPTUAL SITE MODEL

VI is an exposure pathway that results from the migration of volatilized chemicals from the subsurface to indoor air in overlying occupied buildings. A source, migration route and a human receptor must be present for the VI pathway to be complete. The focus of this building specific investigation is to evaluate the potential VI exposure pathway for employees and contractors at Building 969. The CSM is illustrated in Figure 5.3.11-3.

Building 969 is located in the central portion of the facility and is known as the Ag Chem Development Building. The building is multiple stories tall but the office space is on the first floor. The warehouse area is built on a 3.5 ft raised slab. It is approximately $20,250 \text{ ft}^2$ ($1,880 \text{ m}^2$). The building has central air conditioning with four units. The air intakes are located on the roof. There are a total of seven bay doors in the process and warehouse portions of the building that may be left open at various times. The bay doors are not connected to the office areas. The land surrounding the building is comprised of asphalt.

Approximately 20 people occupy Building 969, with 1 to 5 occupants over the weekend. The office occupants work from either 8am to 5pm or 6am to 3pm Monday through Friday. For operations personnel, the building is occupied 24 hours over two 12-hour work shifts. The typical parameters for non-residential exposures are assumed to apply to the various personnel stationed during work shifts at this building (i.e., 40 hours/week, 50 weeks/year exposure).

A building survey completed before the initial sampling event. Drains and other openings were screened with a PID and no soil gas entry points were identified; however, there were a few very minor detections (results <0.5) in the men's and women's bathrooms, kitchenette area and one office. A chemical inventory was completed during the building survey that identified cleaners, anti-static spray, ice eliminator, and lubricants.

EVALUATION OF SEASONAL CONFIRMATION SAMPLING EVENTS

Four seasonal sampling events and one interim monitoring event have been completed at Building 969. The sampling events encompass more than one year of time and include sampling during each season of the year. The results from the four seasonal confirmation sampling events were evaluated with respect to spatial variability, temporal variability, and seasonal trend analysis.

Building specific attenuation factors (α) were calculated and compared between events to evaluate temporal variability and determine the best estimate of a building-specific attenuation factor. This evaluation serves to confirm that the existing study design is appropriate, and also provides insight for the determination of the path forward for this building.

This evaluation focused on any analytes detected in the sub-slab soil gas samples that met the criterion for inclusion in one or more of the following categories:

- a) Analytes detected in sub-slab soil-gas at concentrations that exceeded draft project-specific screening levels;
- b) Analytes detected in sub-slab soil-gas at concentrations of $1,000 \mu\text{g}/\text{m}^3$ or greater in one or more samples. Data for analytes detected above $1,000 \mu\text{g}/\text{m}^3$ should provide the clearest signal and be the simplest to interpret when assessing data trends. The same data trends observed for these analytes are expected to apply to other similar analytes present at lower concentrations; and
- c) PCE and TCE. These two analytes are of particular interest for many VI evaluations at industrial sites.

For this building, the only analytes detected in the sub-slab soil gas at concentrations above the draft project-specific screening levels were 1,1,2-TCA, 1,2,4-TMB, benzene, cumene, ethylbenzene, naphthalene and total xylenes. Seven additional analytes had a detected concentration $\geq 1,000 \mu\text{g}/\text{m}^3$: 1,3,5-TMB, 4-ethyltoluene, CFC-12, cyclohexane, heptane, hexane, and toluene. Due to low detection frequency or intermittent detections, five of those analytes are not included for further evaluation (1,3,5-TMB, 4-ethyltoluene, cyclohexane, hexane, and toluene). CFC-12 and heptane were included for evaluation. Sample results for these analytes are provided below in the following data tables:

Summary of Results for 1,1,2-Trichloroethane (1,1,2-TCA)

Sample Type	Sample ID	Measured Concentration ($\mu\text{g}/\text{m}^3$)			
		Apr. 2017	Feb. 2018	Aug. 2018	Oct. 2018
		E1	E2	E3	E4
Outdoor Air	969-OA-01	<0.16	<0.20	<0.19	>0.17
Indoor Air	969-IA-01	<0.19	<0.36	<0.38	<0.18
	969-IA-02	<0.17	<0.37	<0.24	<0.19
	969-IA-03	<0.16	<0.38	<0.19	<0.17
	969-IA-04	<0.17	<0.19	<0.18	<0.16
	969-IA-05	<0.17	<0.18	<0.19	<0.17
	969-IA-06	<0.18	<0.21	<0.19	<0.18
	969-IA-07	<0.18	<0.20	<0.20	<0.17
	969-IA-08	<0.18	<0.20	<0.19	<0.18
	969-IA-09	<0.18	<0.21	<0.19	<0.19
Sub-Slab Soil Gas	969-SS-01	<4.4	<4.1	<4.3	<4
	969-SS-02	<4.4	<4.1	<5.1	<4.2
	969-SS-03	<4.2	<4.3	<4.4	<4.5
	969-SS-04	<18	<11	<11	<28
	969-SS-05	<86	<43	<150	4,500
	969-SS-06	<22	<42	<42	<29
	969-SS-07	<89	<21	<42	<45
	969-SS-08	<10	<4.3	<220	<84
	969-SS-09	<6.7	<10	<84	<56

Screening levels for indoor air are $0.62 \mu\text{g}/\text{m}^3$ (RIASL₁₂)Screening levels for soil-gas are $20 \mu\text{g}/\text{m}^3$ (RIASL₁₂)**Summary of Results for 1,2,4-Trimethylbenzene (TMB)**

Sample Type	Sample ID	Measured Concentration ($\mu\text{g}/\text{m}^3$)			
		Apr. 2017	Feb. 2018	Aug. 2018	Oct. 2018
		E1	E2	E3	E4
Outdoor Air	969-OA-01	<0.72	<0.89	<0.86	<0.79
Indoor Air	969-IA-01	<0.84	<1.6	<1.7	<0.79
	969-IA-02	<0.79	<1.6	1.5	<0.84
	969-IA-03	1.3	<1.7	3.5	<0.77
	969-IA-04	<0.78	<0.87	<0.82	<0.75
	969-IA-05	<0.78	<0.84	<0.84	<0.76
	969-IA-06	<0.79	<0.97	<0.84	<0.8
	969-IA-07	<0.81	<0.88	<0.88	<0.79
	969-IA-08	<0.81	<0.92	<0.84	<0.81
	969-IA-09	<0.83	<0.96	<0.86	<0.86
Sub-Slab Soil Gas	969-SS-01	<3.9	7.1	12	<3.6
	969-SS-02	<4	3.8	<4.6	<3.8
	969-SS-03	<3.8	<3.9	8.9	<4
	969-SS-04	49	80	45	<25
	969-SS-05	140	<39	<140	<37
	969-SS-06	69	450	910	410
	969-SS-07	200	35	58	200
	969-SS-08	24	<3.9	8,300	5,200
	969-SS-09	11	14	640	240

Screening levels for indoor air are $184 \mu\text{g}/\text{m}^3$ (RIASL₁₂) and $560 \mu\text{g}/\text{m}^3$ (TSRIASL₁₂)
Screening levels for soil-gas are $6,100 \mu\text{g}/\text{m}^3$ (RIASL₁₂) and $18,000 \mu\text{g}/\text{m}^3$ (TSRIASL₁₂)

	RIASL12 Exceedance
	TSRIASL12 Exceedance

Summary of Results for Benzene

Sample Type	Sample ID	Measured Concentration ($\mu\text{g}/\text{m}^3$)			
		Apr. 2017	Feb. 2018	Aug. 2018	Oct. 2018
		E1	E2	E3	E4
Outdoor Air	969-OA-01	0.60	0.41	0.31	0.33
Indoor Air	969-IA-01	0.61	<0.53	<0.56	0.34
	969-IA-02	0.61	<0.54	<0.35	0.94
	969-IA-03	1.1	<0.56	<0.28	0.32
	969-IA-04	0.61	0.32	0.40	0.33
	969-IA-05	0.61	0.34	0.33	0.32
	969-IA-06	1.3	0.37	0.35	0.36
	969-IA-07	0.62	0.42	0.33	0.37
	969-IA-08	0.55	0.43	0.36	1.1
	969-IA-09	0.59	0.42	0.36	0.35
Sub-Slab Soil Gas	969-SS-01	3.6	<2.4	3.9	<2.3
	969-SS-02	8.1	<2.4	<3	<2.5
	969-SS-03	4.8	<2.5	5.1	<2.6
	969-SS-04	96	84	24	<16
	969-SS-05	3,800	1,300	1,600	220
	969-SS-06	42	410	540	660
	969-SS-07	110	44	170	<26
	969-SS-08	27	6.5	15,000	2,000
	969-SS-09	52	46	2,700	560

Screening levels for indoor air are $15.4 \mu\text{g}/\text{m}^3$ (RIASL₁₂) and $54 \mu\text{g}/\text{m}^3$ (TSRIASL₁₂)
Screening levels for soil-gas are $510 \mu\text{g}/\text{m}^3$ (RIASL₁₂) and $1,800 \mu\text{g}/\text{m}^3$ (TSRIASL₁₂)

Summary of Results for Cumene

Sample Type	Sample ID	Measured Concentration ($\mu\text{g}/\text{m}^3$)			
		Apr. 2017	Feb. 2018	Aug. 2018	Oct. 2018
		E1	E2	E3	E4
Outdoor Air	969-OA-01	<0.72	<0.89	<0.86	<0.79
Indoor Air	969-IA-01	<0.84	<1.6	<1.7	<0.79
	969-IA-02	<0.79	<1.6	<1.1	<0.84
	969-IA-03	<0.75	<1.7	<0.86	<0.77
	969-IA-04	<0.78	<0.87	<0.82	<0.75
	969-IA-05	<0.78	<0.84	<0.84	<0.76
	969-IA-06	<0.79	<0.97	<0.84	<0.80
	969-IA-07	<0.81	<0.88	<0.88	<0.79
	969-IA-08	<0.81	<0.92	<0.84	<0.81
	969-IA-09	<0.83	<0.96	<0.86	<0.86
Sub-Slab Soil Gas	969-SS-01	<3.9	<3.7	<3.9	<3.6
	969-SS-02	<4	<3.7	<4.6	<3.8
	969-SS-03	<3.8	<3.9	<4	<4
	969-SS-04	67	16	32	<25
	969-SS-05	86	52	<140	<37
	969-SS-06	<19	42	96	62
	969-SS-07	330	45	120	90
	969-SS-08	<9.2	<3.9	1,300	720
	969-SS-09	7.9	<9.3	160	120

Screening levels for indoor air are $11.4 \mu\text{g}/\text{m}^3$ (RIASL₁₂)
Screening levels for soil-gas are $380 \mu\text{g}/\text{m}^3$ (RIASL₁₂)

	RIASL12 Exceedance
	TSRIASL12 Exceedance

Summary of Results for Ethylbenzene

Sample Type	Sample ID	Measured Concentration ($\mu\text{g}/\text{m}^3$)			
		Apr. 2017	Feb. 2018	Aug. 2018	Oct. 2018
		E1	E2	E3	E4
Outdoor Air	969-OA-01	0.64	0.22	0.27	0.29
Indoor Air	969-IA-01	0.79	0.45	0.59	0.17
	969-IA-02	0.77	0.38	0.61	0.16
	969-IA-03	1.8	<0.3	0.78	0.16
	969-IA-04	0.87	0.23	0.46	0.2
	969-IA-05	0.87	0.26	0.52	0.17
	969-IA-06	0.89	0.23	0.58	0.34
	969-IA-07	3.3	2.7	4.3	1.5
	969-IA-08	1.2	0.72	6	3.9
	969-IA-09	1.2	0.76	1.4	1
Sub-Slab Soil Gas	969-SS-01	19	10	33	<3.1
	969-SS-02	15	5.9	9.8	4.3
	969-SS-03	19	28	76	19
	969-SS-04	140	90	46	<22
	969-SS-05	870	230	260	<32
	969-SS-06	24	360	1,000	530
	969-SS-07	12,000	1,500	3,700	2,600
	969-SS-08	16	5.7	12,000	7,200
	969-SS-09	24	24	3,800	3,400

Screening levels for indoor air are $48 \mu\text{g}/\text{m}^3$ (RIASL₁₂) and $480 \mu\text{g}/\text{m}^3$ (TSRIASL₁₂)
Screening levels for soil-gas are $1,600 \mu\text{g}/\text{m}^3$ (RIASL₁₂) and $16,000 \mu\text{g}/\text{m}^3$ (TSRIASL₁₂)

Summary of Results for Naphthalene

Sample Type	Sample ID	Measured Concentration ($\mu\text{g}/\text{m}^3$)			
		Apr. 2017	Feb. 2018	Aug. 2018	Oct. 2018
		E1	E2	E3	E4
Outdoor Air	969-OA-01	<0.38	<0.47	<0.46	<0.42
Indoor Air	969-IA-01	<0.45	<0.88	<0.92	<0.42
	969-IA-02	<0.42	<0.88	1.3	<0.45
	969-IA-03	<0.40	<0.92	2.3	<0.41
	969-IA-04	<0.42	<0.46	<0.44	<0.40
	969-IA-05	<0.41	<0.44	<0.45	9.1
	969-IA-06	<0.42	<0.52	<0.45	0.50
	969-IA-07	<0.43	<0.47	<0.47	<0.42
	969-IA-08	<0.43	<0.49	<0.45	<0.43
	969-IA-09	<0.44	<0.51	<0.46	<0.46
Sub-Slab Soil Gas	969-SS-01	<8.4	<7.8	<8.3	<7.6
	969-SS-02	<8.4	<7.8	<9.8	<8.2
	969-SS-03	<8.2	<8.3	<8.5	<8.6
	969-SS-04	100	210	130	<53
	969-SS-05	360	<160	<600	<79
	969-SS-06	570	510	1,400	360
	969-SS-07	<340	<41	<160	<86
	969-SS-08	240	<8.3	3,100	820
	969-SS-09	42	21	1,000	<110

Screening levels for indoor air are $3.6 \mu\text{g}/\text{m}^3$ (RIASL₁₂)
Screening levels for soil-gas are $120 \mu\text{g}/\text{m}^3$ (RIASL₁₂)

	RIASL12 Exceedance
	TSRIASL12 Exceedance

Summary of Results for Total Xylenes

Sample Type	Sample ID	Measured Concentration ($\mu\text{g}/\text{m}^3$)				
		Apr. 2017	Feb. 2018	Aug. 2018	Oct. 2018	Aug. 2019
		E1	E2	E3	E4	E5
Outdoor Air	969-OA-01	2.02	.37	1.1	1.06	--
Indoor Air	969-IA-01	2.98	1.39	2.5	0.69	--
	969-IA-02	2.88	0.76	2.63	0.73	--
	969-IA-03	7.4	<0.91	3.54	0.67	--
	969-IA-04	2.92	0.45	1.9	0.69	--
	969-IA-05	2.78	0.67	2.15	0.64	--
	969-IA-06	2.8	0.54	2.3	0.91	--
	969-IA-07	11.7	9.7	18	5.6	--
	969-IA-08	3.96	2.25	25.5	15.6	<0.45
	969-IA-09	4.19	2.5	5.7	3.94	--
Sub-Slab Soil Gas	969-SS-01	97	48	160	7.3	--
	969-SS-02	49	16.6	37.9	12	--
	969-SS-03	67	114	367	95	--
	969-SS-04	290	210	149	<0.44	--
	969-SS-05	920	177	<240	34	--
	969-SS-06	169	1,980	2,900	1,650	--
	969-SS-07	42,800	5,600	14,500	11,100	--
	969-SS-08	55	14.7	34,000	34,000	--
	969-SS-09	62	53	18,500	16,800	--

Screening levels for indoor air are $680 \mu\text{g}/\text{m}^3$ (RIASL₁₂) and $2,000 \mu\text{g}/\text{m}^3$ (TSRIASL₁₂)
Screening levels for soil-gas are $22,000 \mu\text{g}/\text{m}^3$ (RIASL₁₂) and $67,000 \mu\text{g}/\text{m}^3$ (TSRIASL₁₂)

Summary of Results for Chlorofluorocarbon (CFC-12)

Sample Type	Sample ID	Measured Concentration ($\mu\text{g}/\text{m}^3$)				
		Apr. 2017	Feb. 2018	Aug. 2018	Oct. 2018	Aug. 2019
		E1	E2	E3	E4	E5
Outdoor Air	969-OA-01	2	2.5	2.2	1.9	--
Indoor Air	969-IA-01	2	2.5	2.2	1.6	--
	969-IA-02	2	2.6	2.4	1.9	--
	969-IA-03	2.1	2.3	2.3	1.9	--
	969-IA-04	8.3	4.5	9.3	6.6	--
	969-IA-05	6	3.6	8.8	4.6	--
	969-IA-06	7.5	4.8	11	6.8	--
	969-IA-07	7.9	8.5	9.9	2.4	--
	969-IA-08	8.2	10	9.7	2.9	--
	969-IA-09	8.7	11	9.7	7.2	--
Sub-Slab Soil Gas	969-SS-01	6.4	5.5	5.3	6.5	--
	969-SS-02	5.8	5.1	5.8	5.6	--
	969-SS-03	10	8.5	12	6.6	--
	969-SS-04	4,400	3,500	3,200	8,500	--
	969-SS-05	2,700	3,800	1,500	1,800	--
	969-SS-06	3,300	4,100	2,000	7,800	--
	969-SS-07	580	1,100	1,400	520	--
	969-SS-08	710	790	1,500	1,800	--
	969-SS-09	2,300	2,800	670	2,400	--

Screening levels for indoor air are $1,020 \mu\text{g}/\text{m}^3$ (RIASL₁₂)
Screening levels for soil-gas are $34,000 \mu\text{g}/\text{m}^3$ (RIASL₁₂)

	RIASL12 Exceedance
	TSRIASL12 Exceedance

Summary of Results for Heptane

Sample Type	Sample ID	Measured Concentration ($\mu\text{g}/\text{m}^3$)				
		Apr. 2017	Feb. 2018	Aug. 2018	Oct. 2018	Aug. 2019
		E1	E2	E3	E4	E5
Outdoor Air	969-OA-01	1.5	11	0.79	<0.66	--
Indoor Air	969-IA-01	1.4	4	<1.4	<0.66	--
	969-IA-02	1.6	8.1	<0.9	<0.7	--
	969-IA-03	2.3	4.4	1	<0.64	--
	969-IA-04	1.6	3.1	0.77	5.2	--
	969-IA-05	1.5	5.7	0.86	4.8	--
	969-IA-06	1.4	2.1	0.91	1.4	--
	969-IA-07	1.5	4	1.4	1.6	--
	969-IA-08	1.4	6.9	0.87	<0.67	--
	969-IA-09	1.6	3.3	0.77	<0.71	--
Sub-Slab Soil Gas	969-SS-01	<3.3	<3	<3.2	<3	--
	969-SS-02	14	<3	<3.8	3.3	--
	969-SS-03	11	4	5.6	<3.4	--
	969-SS-04	62	32	19	<21	--
	969-SS-05	2,600	1,800	1,600	390	--
	969-SS-06	36	1,400	1,200	1,500	--
	969-SS-07	<67	20	140	<34	--
	969-SS-08	12	4.5	5,600	3,600	--
	969-SS-09	21	13	1,200	1,900	--

Screening levels for indoor air are 10,800 $\mu\text{g}/\text{m}^3$ (RIASL₁₂)

Screening levels for soil-gas are 36 0,000 $\mu\text{g}/\text{m}^3$ (RIASL₁₂)

	RIASL12 Exceedance
	TSRIASL12 Exceedance

EVALUATION OF VI DATA TRENDS

Data trends for Building 969 are discussed below for both sub-slab soil gas and indoor air. When data exhibit a narrow range of variability, it is typical practice to express the range as a percentage (e.g., relative percent difference [RPD]). When data exhibit a large range of variability, however, it is more useful to express the range in orders of magnitude (i.e., factors of 10). This can be expressed mathematically as the log of the ratio of maximum/minimum values. If the values differ by a factor of 10, the log of the ratio is 1, if the values differ by a factor of 100, the log of the ratio is 2, and so on.

The variability across all locations over all sampling events is the total variability. This encompasses different types of variability, including spatial variability (i.e., how do the results vary from location to location), temporal variability (i.e., how do the results at a given location vary over time), and measurement variability. Measurement variability can be determined by evaluating results of duplicate or collocated samples and includes both sampling variability and analytical variability.

Sub-Slab Soil Gas Data Trends

Spatial Variability of Sub-Slab Soil Gas – The soil gas exhibit up to three orders of magnitude of spatial variability. For example, sub-slab soil gas detections of benzene vary from 3.9 to 15,000 $\mu\text{g}/\text{m}^3$ (log of max./min. = 3.6) across all nine locations for E3. Sub-slab soil gas detections of ethylbenzene range from 9.8 to 12,000 $\mu\text{g}/\text{m}^3$ (log of max./min. = 3.1) across all nine locations for E3. Concentrations of total xylenes in sub-slab soil gas vary from 49 to 4,200 $\mu\text{g}/\text{m}^3$ (log max./min. = 2.9) across all nine location for E1. For CFC-12, sub-slab soil gas concentrations range from 5.6 $\mu\text{g}/\text{m}^3$ to 8,500 $\mu\text{g}/\text{m}^3$ (log max./min. = 3.2). Based on this data, there is a large amount of spatial variability in sub-slab soil gas.

Temporal Variability of Soil Gas – The soil gas concentrations also exhibit up to 3 orders of magnitude of temporal variability. For benzene, sub-slab soil gas concentrations of vary from 27 to 15,000 $\mu\text{g}/\text{m}^3$ at location 969-SS-08 (log max/min = 3.4). For ethylbenzene, sub-slab soil gas concentrations of vary from 5.7 to 12,000 $\mu\text{g}/\text{m}^3$ at location 969-SS-08 (log max/min = 3.3). Sub-slab soil gas concentrations of naphthalene vary from 360 to 1,400 $\mu\text{g}/\text{m}^3$ at location 969-SS-06 (log max/min = 0.60). Sub-slab soil gas concentrations of CFC-12 vary from 3,200 to 8,500 $\mu\text{g}/\text{m}^3$ at location 969-SS-04 (log max/min = 0.42). Overall, contrary to expectations, the amount of temporal variability is similar to the amount of spatial variability.

Seasonal Confirmation Sampling Trend Analysis – No formal statistical tests were performed, but the data exhibits relatively consistent results between the seasons. This is demonstrated by the graph below, which shows the six of the analytes selected above at locations where they were detected at the highest concentrations. Note that the y-axis is a log scale.

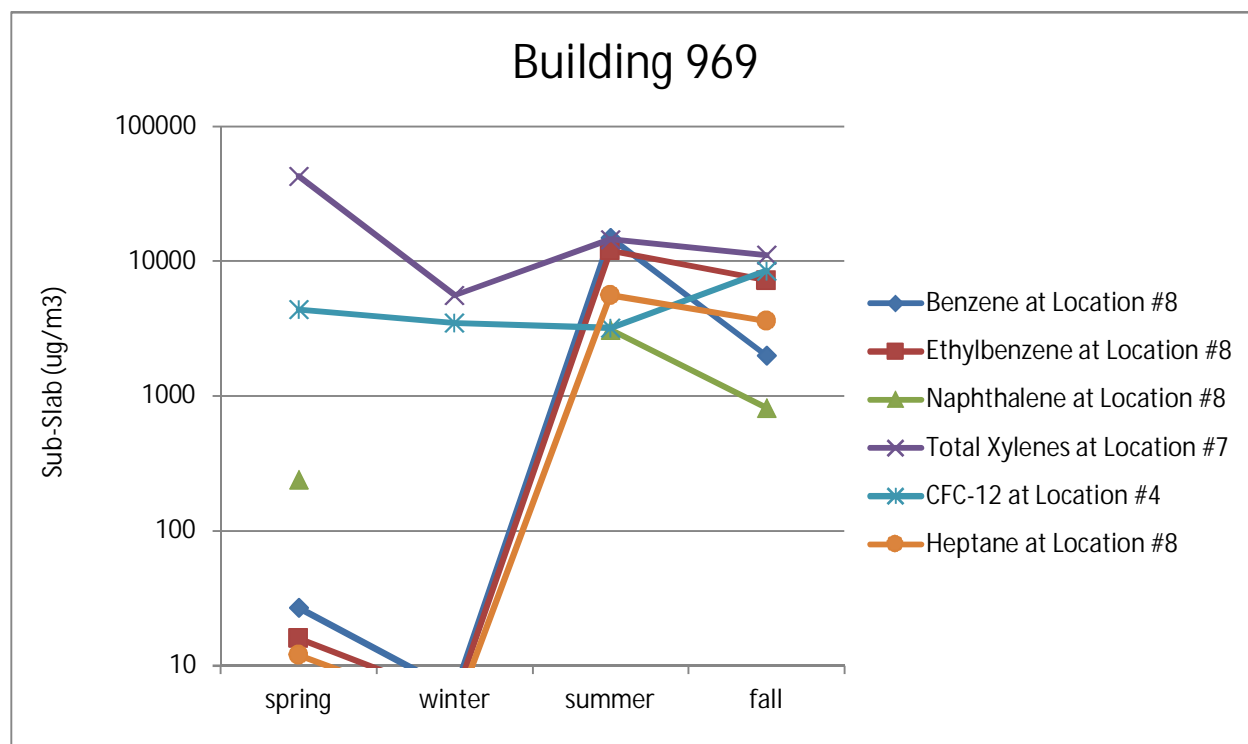

The data set was examined to see what the potential consequences would have been had only a single sampling event been performed. For benzene, ethylbenzene, heptane and chloroform, the highest sub-slab soil gas concentrations were collected during the summer (E3) and the lowest concentrations occurred during the winter (E2). For total xylenes and CFC-12, the highest sub-slab concentrations were collected during the spring (E1) and fall (E4), respectively, and the lowest concentrations occurred during the winter (E2) and summer (E3), respectively. Overall, the minimum and maximum values appear to vary between the sampling locations and events.

For benzene, a concentration of 27 $\mu\text{g}/\text{m}^3$ was measured during E1 and the highest concentration (15,000 $\mu\text{g}/\text{m}^3$) was measured during E3. If only E1 had been performed, a negative bias of over a factor of 500 would have been introduced (i.e., the E3 result was over 500 times higher than the E1 result). For naphthalene, the lowest detected value (240 $\mu\text{g}/\text{m}^3$) was measured during E1 and the highest concentration (3,100 $\mu\text{g}/\text{m}^3$) was measured during E3. If only E1 had been performed, a negative bias of a factor of 12 would have been introduced. Therefore, implementing four seasonal confirmation sampling events provided insight regarding maximum concentration levels and the larger data set served to increase the confidence in the findings.

Indoor Air Data Trends

Spatial Variability of Indoor Air – The indoor air exhibits approximately one order of magnitude of spatial variability. Benzene had 100% detection frequency in indoor air during E1 and E4. During E4, indoor air concentrations of benzene vary from 0.32 to 1.1 $\mu\text{g}/\text{m}^3$ (log max./min. = 0.54). For ethylbenzene, the highest spatial variability also occurred during E4 where indoor air concentrations vary from 0.16 to 3.9 $\mu\text{g}/\text{m}^3$ (log max./min. = 1.4). The highest spatial variability occurred for total xylenes in E4 when concentrations ranged from 0.64 to 15.6 $\mu\text{g}/\text{m}^3$ (log max./min. = 1.4).

Temporal Variability of Indoor Air – The indoor air has, at most, one order of magnitude of temporal variability. For example, indoor air concentrations of benzene at location 969-IA-06 varied from 0.35 to 1.3 $\mu\text{g}/\text{m}^3$ (log of max./min. = 0.57). For ethylbenzene at location 969-IA-08, concentrations varied from 0.72 to 6 $\mu\text{g}/\text{m}^3$ (log max./min. = 0.92). Indoor air concentrations of total xylenes at 969-IA-08 varied from 2.25 to 25.5 $\mu\text{g}/\text{m}^3$ (log max./min. = 1.1). Overall, temporal variability across the four seasons sampled is relatively small.

Additional Analyses

Comparison of Sub-Slab Soil Gas and Indoor Air Data Sets – As expected, the sub-slab soil gas data exhibit greater spatial variability than the indoor air data set. The sub-slab soil gas also exhibits greater temporal variability than the indoor air data set, which is contrary to expectations. This suggests that there are not significant indoor sources of the AOlS or that emissions from any indoor air sources tend to be well distributed in this building.

Seasonal Effects – The sub-slab soil gas data exhibit a fair amount of variability from event to event. Maximum sub-slab soil gas values for benzene, ethylbenzene and naphthalene occurred in E3 (summer). For total xylenes and CFC-12, maximum sub-slab soil gas concentrations were detected in E1 (spring) and E4 (fall), respectively. Maximum indoor air values for most of the analytes evaluated occurred in the spring (E1) or summer (E3). The data vary but do not support the hypothesis that wintertime should have the highest indoor air impacts.

Comparison of Attenuation Factors by Event – Attenuation factors were calculated for CFC-12 based on maximum values since CFC-12 had 100% detection frequency in both media. However, detections in outdoor air were very similar to detected indoor air concentrations for all three analytes. Therefore, the indoor air maximum concentration was corrected for contribution of outdoor air to indoor air (e.g., outdoor air detected concentration was subtracted from indoor air concentration). The calculated event-specific attenuation factors are shown in Tables 969-3.

Table 969-3. Comparison of Building-Specific Attenuation Factors for CFC-12 by Event

	E1 (Spring)	E2 (Winter)	E3 (Summer)	E4 (Fall)
Maximum Values				
CFC-12 in Sub-Slab Soil Gas ($\mu\text{g}/\text{m}^3$)	4,400	4,100	3,200	8,500
CFC-12 in Outdoor Air ($\mu\text{g}/\text{m}^3$)	2	2.5	2.2	1.9
CFC-12 in Indoor Air ($\mu\text{g}/\text{m}^3$)	8.7	11	11	7.2
CFC-12 in Indoor Air ($\mu\text{g}/\text{m}^3$) Corrected for Outdoor Air Contribution	6.7	8.5	8.8	5.3
Attenuation Factor	1.5E-03	2.1E-03	2.75E-03	6.2E-04

These serve as the best estimates of attenuation at this building. The results can vary from day to day due to differences in rates of vapor intrusion and rates of building ventilation. Overall, the most conservative estimate of a building-specific attenuation factor for Building 969 is 1.5E-03 based on CFC-12 during E1.

Temporal Variability in Attenuation Factor – As shown in Table 969-3, there was about one order of magnitude of temporal variability in the calculated attenuation factors observed for CFC-12. To be as conservative as possible, the maximum values were used in calculating the attenuation factor for each event. The sampling location with the maximum value per event varied. Generally, the maximum indoor air values were similar across events. In general, the low spatial variability in indoor air results means that roughly comparable attenuation factors would be obtained whichever indoor air value was used in the calculations.

NON-DETECT EVALUATION

Table 969-4 below lists the analytes in sub-slab soil gas that have ND RLs greater than the screening levels. The table also includes the indoor air results for each of the analytes. If a sub-slab soil gas analyte has ND RL exceedances, but all results and ND RLs in indoor air are below the screening levels, no further evaluation is warranted. If an analyte was identified as an AOI in sub-slab soil gas (detected results > screening level), it is excluded from the ND evaluation. Also, if an ND analyte has an 0% detection frequency for all sampling events and all ND RLs met the screening level during at least one event, no further ND evaluation is warranted.

Table 969-4. Non-Detect Evaluation for Building 969

Soil Gas Analytes with ND RL > SL	Indoor Air Result Summary
1,1,2,2-Tetrachloroethane	0% Detection Frequency, All ND RLs < RIASL ₁₂
1,1,2-Trichloroethane	0% Detection Frequency, All ND RLs < RIASL ₁₂
1,2,4-Trichlorobenzene	0% Detection Frequency, All ND RLs < TSRIASL ₁₂
1,2-Dibromoethane (EDB)	0% Detection Frequency, All ND RLs > RIASL ₁₂
1,2-Dichloroethane	0%-11% Detection Frequency, All detects and ND RLs < RIASL ₁₂
alpha-Chlorotoluene	0% Detection Frequency, All ND RLs < RIASL ₁₂
Bromodichloromethane	0%-33% Detection Frequency, All detects and ND RLs < RIASL ₁₂
Chloroform	68%-78% Detection Frequency, All detects and ND RLs < RIASL ₁₂
Dibromochloromethane	0%-22% Detection Frequency, All detects and ND RLs < RIASL ₁₂
Dibromomethane	0% Detection Frequency, All ND RLs < RIASL ₁₂
Hexachlorobutadiene (HCBD)	0% Detection Frequency, All ND RLs > RIASL ₁₂
Trichloroethene	11%-33% Detection Frequency, All detects and ND RLs < RIASL ₁₂

WEIGHT-OF-EVIDENCE SUMMARY

Building 969 was confirmed as a VI Path Forward Group 2 building due to its potential for VI based on sub-slab soil gas exceedances of the draft project-specific RIASL₁₂ and/or TSRIASL₁₂ for 1,1,2-TCA, 1,2,4-TMB, benzene, cumene, ethylbenzene, naphthalene, and total xylenes. However, after further investigation and evaluation, the following evidence supports the conclusion that VI is insignificant at Building 969:

- No exceedances of draft project-specific screening levels in indoor air, with the exception of a single exceedance of naphthalene that did not have a correlated sub-slab soil gas sample exceedance. TCE and chloroform also had limited indoor air exceedances and no exceedances in sub-slab soil gas throughout any of the seasonal confirmation sampling events.
- The data do not support the hypothesis that wintertime should have the highest indoor air impacts. The highest sub-slab soil gas concentrations generally were measured in the summer. Similarly, the highest indoor air concentrations were measured in the spring and summer.

- The indoor air data show relatively little spatial variability, despite the greater spatial variability in the sub-slab soil gas values. This evaluation confirms that the sub-slab soil gas and indoor air concentrations were relatively constant from season to season.
- As shown in the table below, the building-specific attenuation factor yields estimated indoor air concentrations for EDB and HCBd well below the RIASL₁₂; furthermore, lower reporting limits were achieved for each of these ND analytes in other events and the analytes remained ND.

Parameters	EDB	HCBd
Building-specific AF	1.5E-03	1.5E-03
Maximum reporting limit in SSSG	<61	<340
Estimated Indoor Air Concentration	0.09	0.51
Indoor Air ND RL	<0.26	<9.1
Indoor Air RIASL ₁₂	0.2	5.4

Based on the CSM for Building 969, VI is an insignificant exposure pathway for current building utilization.

PATH FORWARD

Based on the evaluation of the four seasonal confirmation sampling events, the VI pathway continues to be insignificant for Building 969. Sufficient information exists to make a human exposure under control EI determination. However, while currently there is no evidence of potential VI, for future use, LTM is warranted and the building-specific Interim Monitoring Plan is discussed below.

Building-specific Interim Monitoring Plan

Dow presented an interim monitoring plan for Building 969 during the February 2019 Corrective Action status meeting. Interim monitoring will be performed semi-annually and monitoring began in August 2019. Dow will implement the interim monitoring plan at Building 969 until a revised program or more permanent corrective action plan is developed for the site.

Indoor air is being monitored at location 969-IA-08. This location was selected for continued monitoring since it demonstrated the highest sub-slab soil gas results. Monitoring is performed for 1,1,2-TCA, 1,2,4-TMB, benzene, cumene, ethylbenzene, naphthalene and total xylenes. The results of the initial interim monitoring event are shown below.

Indoor Air Analyte	Result Value (µg/m ³)	Reporting Limit (µg/ m ³)	EGLE Project-Specific RIASL ₁₂ (µg/ m ³)	NONRES TSRIASL ₁₂ (µg/ m ³)	Dow IH OEL (8hr Time Weighted Average) (µg/ m ³)
1,1,2-Trichloroethane	ND	0.19	0.62	NA	54,600
1,2,4-Trimethylbenzene	ND	0.85	184	560	125,000
Benzene	0.44	0.28	15.4	54	1,595
Cumene	ND	0.85	11.4	NA	246,000
Ethyl Benzene	3.8	0.15	48	480	86,800
Naphthalene	ND	0.45	3.6	NA	52,400
Total Xylenes	ND	0.45	680	2000	434,000

As shown in the table above, all indoor air results from the summer 2019 IM event were ND with RLs below the indoor air RIASL₁₂ or had detected results below the RIASL₁₂. The analytical data is presented in Appendix A. Field sampling forms are provided in Appendix B. The next IM event is scheduled for winter 2019/2020. Semi-annual interim monitoring will continue in the summer and winter of 2020.

5.3.12 VI Seasonal Confirmation Sampling Results Evaluation for Building 1222

INTRODUCTION

Building 1222 is a Category 2 building in Zone 2 Phase 1. Building 1222 has a maintenance shop with office space and is approximately 16,340 ft². It is known as the Dursban Maintenance and is located within the central portion of the facility designated as Zone 2 (Figure 5.3.12-1).

The initial evaluation in the 2017 CAIP concluded that based on the indoor air results, the VI pathway at Building 1222 is an insignificant exposure pathway based on current use and was placed into VI Path Forward Building Group 1 and no further VI evaluation was warranted at that time. The results from the initial sampling event were re-evaluated in the 2018 Rescreen Report and presented again in the 2018 CAIP. No indoor air analytes were detected above screening levels at Building 1222; however, based on sub-slab soil gas results greater than screening levels for EDC, CFC-11, CFC-12, chloroform, hexane, and TCE, Building 1222 was moved into VI Path Forward Building Group 2 and seasonal confirmation sampling was conducted.

Building 1222	
Initial Sampling Event	Completed
E1	April 2017 (Spring)
Seasonal Sampling Event	Completed
E2	November 2018 (Fall)
E3	February 2019 (Winter)
E4	August 2019 (Summer)

Based on the evaluation of the four seasonal confirmation sampling events, the VI pathway continues to be insignificant. Sufficient information exists to make a human exposure under control EI determination.

SUB-SLAB SOIL GAS RESULTS EVALUATION

Sub-slab soil gas samples were collected from nine locations from within the building. Indoor air samples were collected at nine locations corresponding to the soil gas sample locations, along with an outdoor air sample from the main air intake. The sampling locations are shown on Figure 5.3.12-2. Summary statistics and screening comparison results are presented for sub-slab soil gas on Table 5.3.12-A and indoor and outdoor air on Table 5.3.12-B. The analytical reports for the sub-slab soil gas and indoor and outdoor air samples are presented in Appendix A. Field sampling logs are presented in Appendix B. Table 1222-1 presents the sub-slab soil gas results that exceed the draft project-specific screening levels.

Table 1222-1. Summary of Sub-Slab Soil Gas Exceedances for Building 1222

Analyte (Sampling Event)	Detection Frequency	Measured Range of Detects ($\mu\text{g}/\text{m}^3$)	% Detections > Screening Level	Screening Level* ($\mu\text{g}/\text{m}^3$)
1,2-Dichloroethane (1)	11%	400	11%	150
1,2-Dichloroethane (2)	0%	ND	0%	150
1,2-Dichloroethane (3)	0%	ND	0%	150
1,2-Dichloroethane (4)	11%	490	11%	150
CFC-11 (1)	100%	10,000 - 180,000	44%	45,000
CFC-11 (2)	100%	23,000 - 150,000	56%	45,000
CFC-11 (3)	100%	1,800 - 170,000	44%	45,000
CFC-11 (4)	100%	5,000 - 210,000	44%	45,000
CFC-12 (1)	100%	400 - 240,000	22%	34,000
CFC-12 (2)	100%	1,000 - 360,000	22%	34,000
CFC-12 (3)	100%	46 - 360,000	22%	34,000
CFC-12 (4)	100%	250 - 540,000	11%	34,000

Analyte (Sampling Event)	Detection Frequency	Measured Range of Detects ($\mu\text{g}/\text{m}^3$)	% Detections > Screening Level	Screening Level* ($\mu\text{g}/\text{m}^3$)
Chloroform (1)	0%	ND	0%	170
Chloroform (2)	11%	1,400	11%	170
Chloroform (3)	11%	1,400	11%	170
Chloroform (4)	11%	210	11%	170
Hexane (1)	44%	30 - 18,000	0%	72,000
Hexane (2)	11%	33,000	0%	72,000
Hexane (3)	11%	2,700	0%	72,000
Hexane (4)	33%	13 - 86,000	11%	72,000
Trichloroethene (1)	11%	180	11%	130
Trichloroethene (2)	22%	160 - 440	22%	130
Trichloroethene (3)	11%	79	0%	130
Trichloroethene (4)	22%	130 - 230	11%	130

*Screening level provided is the draft project-specific RIASL₁₂.

Table 1222-2 summarizes the indoor air results relative to the sub-slab soil gas exceedances, since VI only potentially occurs if the analyte is present in both sub-slab soil gas and indoor air. Therefore, the table below provides the analyte detected above applicable screening levels in sub-slab soil gas as well as the corresponding indoor air sample result. The outdoor air sample result is also provided to determine if the analytes were present in indoor air due to migration from outdoor air.

Table 1222-2. Vapor Intrusion Evaluation for Building 1222

Analyte	Indoor Air Detection Frequency	Indoor Air Measured Range ($\mu\text{g}/\text{m}^3$)	Indoor Air Screening Level* ($\mu\text{g}/\text{m}^3$)	Outdoor Air Result ($\mu\text{g}/\text{m}^3$)
1,2-Dichloroethane (1)	0%	ND	4.6	ND
1,2-Dichloroethane (2)	100%	0.47 - 0.59	4.6	0.61
1,2-Dichloroethane (3)	0%	ND	4.6	ND
1,2-Dichloroethane (4)	22%	0.18 - 0.20	4.6	ND
CFC-11 (1)	100%	1.1 - 1.3	1,340	1.1
CFC-11 (2)	100%	1.6 - 2.9	1,340	1
CFC-11 (3)	100%	1.5 - 2.4	1,340	1.2
CFC-11 (4)	100%	1.1 - 1.9	1,340	1.2
CFC-12 (1)	100%	2 - 2.1	1,020	2
CFC-12 (2)	100%	2.2 - 3.4	1,020	2.1
CFC-12 (3)	100%	2.1 - 2.4	1,020	2.1
CFC-12 (4)	100%	1.8 - 2.4	1,020	1.9
Chloroform (1)	78%	0.18 - 0.53	5.2	ND
Chloroform (2)	100%	0.38 - 0.87	5.2	0.22
Chloroform (3)	100%	0.35 - 1.1	5.2	0.41
Chloroform (4)	100%	0.34 - 2.3	5.2	0.46
Hexane (1)	78%	0.88 - 1.3	2,200	1.2
Hexane (2)	33%	0.69 - 1.9	2,200	ND
Hexane (3)	100%	0.59 - 1.6	2,200	ND
Hexane (4)	0%	ND	2,200	ND
Trichloroethene (1)	0%	ND	4	ND
Trichloroethene (2)	0%	ND	4	ND
Trichloroethene (3)	33%	0.20 - 0.31	4	ND
Trichloroethene (4)	11%	0.21	4	ND

All indoor air results for Building 1222 are below screening levels.

VAPOR INTRUSION CONCEPTUAL SITE MODEL

VI is an exposure pathway that results from the migration of volatilized chemicals from the subsurface to indoor air in overlying occupied buildings. A source, migration route and a human receptor must be present for the VI pathway to be complete. The focus of this building specific investigation is to evaluate the potential VI exposure pathway for employees and contractors at Building 1222. The CSM is illustrated in Figure 5.3.12-3.

Building 1222 has a maintenance shop with office space. It is known as the Dursban Maintenance Building and is approximately 16,340 ft². The building has a central air conditioning unit with one air intake at the top of the building near the center of the roof. There is a kitchen range hood fan in the kitchen space and mechanical fans in the shop areas. There are four bay doors, two in each shop. The building has an attached garage where trucks can be parked. The land surrounding the building is covered primarily in asphalt, with some gravel and grass to the north and east.

Approximately 20-25 people occupy Building 1222. The building is occupied from 6am to 4pm Monday through Thursday by personnel for 10-hour shifts per day. The typical parameters for non-residential exposures are assumed to apply to the various personnel stationed during work shifts at this building (i.e., 40 hours/week, 50 weeks/year exposure).

A building survey was completed before the initial sampling event. Drains and other openings were screened with a PID and no soil gas entry points were identified. A chemical inventory was completed during the building survey that identified cleaners, degreasers, and rust cutting spray.

EVALUATION OF SEASONAL CONFIRMATION SAMPLING EVENTS

Four seasonal sampling events have been completed at Building 1222. The sampling events encompass more than one year of time and include sampling during each season of the year. The results from the four seasonal confirmation sampling events were evaluated with respect to spatial variability, temporal variability, and seasonal trend analysis.

Building specific attenuation factors (α) were calculated and compared between events to evaluate temporal variability and determine the best estimate of a building-specific attenuation factor. This evaluation serves to confirm that the existing study design is appropriate, and also provides insight for the determination of the path forward for this building.

This evaluation focused on any analytes detected in the sub-slab soil gas samples that met the criterion for inclusion in one or more of the following categories:

- a) Analytes detected in sub-slab soil-gas at concentrations that exceeded draft project-specific screening levels;
- b) Analytes detected in sub-slab soil-gas at concentrations of 1,000 $\mu\text{g}/\text{m}^3$ or greater in one or more samples. Data for analytes detected above 1,000 $\mu\text{g}/\text{m}^3$ should provide the clearest signal and be the simplest to interpret when assessing data trends. The same data trends observed for these analytes are expected to apply to other similar analytes present at lower concentrations; and
- c) PCE and TCE. These two analytes are of particular interest for many VI evaluations at industrial sites.

For this building, the analytes detected in the sub-slab soil gas at concentrations above the draft project-specific screening levels were EDC, CFC-11, CFC-12, chloroform, hexane and TCE. The following additional analytes had detected concentrations $\geq 1,000 \mu\text{g}/\text{m}^3$: 1,1,1-TCA, cyclohexane, heptane, PCE and chloromethane. Only 1,1,1-TCA is included for further evaluation. The remaining analytes had low

detection frequencies and were either detected in one event or in only one sample per event. Sample results for these analytes are provided in the following data tables below:

Summary of Results for 1,2-Dichloroethane

Sample Type	Sample ID	Measured Concentration (µg/m ³)			
		Apr. 2017	Nov. 2018	Feb. 2019	Aug. 2019
		E1	E2	E3	E4
Outdoor Air	1222-OA-01	<0.14	0.61	<0.12	<0.14
Indoor Air	1222-IA-01	<0.13	0.54	<0.13	<0.13
	1222-IA-02	<0.13	0.56	<0.13	<0.12
	1222-IA-03	<0.14	0.57	<0.12	<0.14
	1222-IA-04	<0.14	0.57	<0.12	<0.12
	1222-IA-05	<0.14	0.50	<0.12	<0.14
	1222-IA-06	<0.14	0.47	<0.14	<0.14
	1222-IA-07	<0.13	0.55	<0.13	<0.22
	1222-IA-08	<0.14	0.59	--	0.18
	1222-IA-09	<0.13	0.58	<0.14	0.2
Sub-Slab Soil Gas	1222-SS-01	<33	<65	<66	<68
	1222-SS-02	<32	<33	<13	<12
	1222-SS-03	<1,600	<850	<1,000	<44
	1222-SS-04	<43	<31	<4.5	<31
	1222-SS-05	<66	<66	<29	<65
	1222-SS-06	400	<260	<32	490
	1222-SS-07	<61	<33	<63	<32
	1222-SS-08	<21	<33	<43	<43
	1222-SS-09	<1,600	<1,600	<1,500	<3,200

Screening levels for indoor air are 4.6 µg/m³ (RIASL₁₂)
Screening levels for sub-slab soil gas are 150 µg/m³ (RIASL₁₂)

	RIASL12 Exceedance
	TSRIASL12 Exceedance

Summary of Results for CFC-11

Sample Type	Sample ID	Measured Concentration ($\mu\text{g}/\text{m}^3$)			
		Apr. 2017	Nov. 2018	Feb. 2019	Aug. 2019
		E1	E2	E3	E4
Outdoor Air	1222-OA-01	1.1	1	1.2	1.2
Indoor Air	1222-IA-01	1.2	1.9	1.7	1.8
	1222-IA-02	1.2	1.7	1.8	1.5
	1222-IA-03	1.2	2.9	2	1.9
	1222-IA-04	1.1	1.6	1.6	1.4
	1222-IA-05	1.1	1.9	1.5	1.1
	1222-IA-06	1.1	1.8	1.7	1.4
	1222-IA-07	1.2	1.7	1.7	1.6
	1222-IA-08	1.3	2	--	1.7
	1222-IA-09	1.2	2	1.6	1.6
Sub-Slab Soil Gas	1222-SS-01	17,000	100,000	95,000	120,000
	1222-SS-02	18,000	23,000	5,200	5,000
	1222-SS-03	150,000	130,000	170,000	15,000
	1222-SS-04	23,000	31,000	1,800	30,000
	1222-SS-05	92,000	150,000	55,000	140,000
	1222-SS-06	180,000	88,000	9,400	210,000
	1222-SS-07	30,000	43,000	20,000	30,000
	1222-SS-08	10,000	25,000	14,000	16,000
	1222-SS-09	73,000	82,000	90,000	99,000

Screening levels for indoor air are 1,340 $\mu\text{g}/\text{m}^3$ (RIASL₁₂)
Screening levels for sub-slab soil gas are 45,000 $\mu\text{g}/\text{m}^3$ (RIASL₁₂)

Summary of Results for Chlorofluorocarbon (CFC-12)

Sample Type	Sample ID	Measured Concentration ($\mu\text{g}/\text{m}^3$)			
		Apr. 2017	Nov. 2018	Feb. 2019	Aug. 2019
		E1	E2	E3	E4
Outdoor Air	1222-OA-01	2	2.1	2.1	1.9
Indoor Air	1222-IA-01	2.1	2.7	2.2	2.2
	1222-IA-02	2.1	2.4	2.4	2.1
	1222-IA-03	2.1	3.4	2.2	2.4
	1222-IA-04	2.1	2.4	2.2	2.1
	1222-IA-05	2	2.3	2.1	2
	1222-IA-06	2	2.2	2.1	2.2
	1222-IA-07	2.1	2.3	2.2	2.4
	1222-IA-08	2.1	2.4	--	1.8
	1222-IA-09	2	2.6	2.1	1.9
Sub-Slab Soil Gas	1222-SS-01	480	3,200	2,800	4,600
	1222-SS-02	1,300	1,700	310	250
	1222-SS-03	160,000	140,000	220,000	12,000
	1222-SS-04	1,100	1,000	46	980
	1222-SS-05	1,600	2,800	1,000	2,800
	1222-SS-06	3,700	2,000	260	3,900
	1222-SS-07	570	1,100	460	1,100
	1222-SS-08	400	1,000	530	730
	1222-SS-09	240,000	360,000	360,000	540,000

Screening levels for indoor air are 1,020 $\mu\text{g}/\text{m}^3$ (RIASL₁₂)
Screening levels for sub-slab soil gas are 34,000 $\mu\text{g}/\text{m}^3$ (RIASL₁₂)

	RIASL12 Exceedance
	TSRIASL12 Exceedance

Summary of Results for Chloroform

Sample Type	Sample ID	Measured Concentration ($\mu\text{g}/\text{m}^3$)			
		Apr. 2017	Nov. 2018	Feb. 2019	Aug. 2019
		E1	E2	E3	E4
Outdoor Air	1222-OA-01	<0.17	0.22	0.41	0.46
Indoor Air	1222-IA-01	0.19	0.54	0.77	0.66
	1222-IA-02	0.20	0.54	0.89	0.62
	1222-IA-03	0.21	0.60	0.42	0.77
	1222-IA-04	0.24	0.50	0.82	0.64
	1222-IA-05	<0.16	0.42	0.35	0.34
	1222-IA-06	0.17	0.38	0.42	0.49
	1222-IA-07	0.20	0.52	0.85	1.3
	1222-IA-08	0.53	0.87	--	2.3
	1222-IA-09	0.18	0.56	0.95	1
Sub-Slab Soil Gas	1222-SS-01	<40	<78	<80	<82
	1222-SS-02	<39	<40	<15	<14
	1222-SS-03	<2,000	1,400	1,400	210
	1222-SS-04	<52	<37	<5.4	<37
	1222-SS-05	<80	<80	<35	<79
	1222-SS-06	<400	<310	<39	<160
	1222-SS-07	<74	<40	<76	<39
	1222-SS-08	<26	<40	<52	<52
	1222-SS-09	<1,900	<1,900	<1,800	<3,800

Screening levels for indoor air are $5.2 \mu\text{g}/\text{m}^3$ (RIASL₁₂) and $52 \mu\text{g}/\text{m}^3$ (TSRIASL₁₂)
Screening levels for sub-slab soil gas are $170 \mu\text{g}/\text{m}^3$ (RIASL₁₂) and $1,700 \mu\text{g}/\text{m}^3$ (TSRIASL₁₂)

Summary of Results for Hexane

Sample Type	Sample ID	Measured Concentration ($\mu\text{g}/\text{m}^3$)			
		Apr. 2017	Nov. 2018	Feb. 2019	Aug. 2019
		E1	E2	E3	E4
Outdoor Air	1222-OA-01	1.2	<0.57	<0.54	<3
Indoor Air	1222-IA-01	1.3	<0.61	1	<2.8
	1222-IA-02	1.1	<0.60	1.2	<2.7
	1222-IA-03	1.1	0.69	1.6	<3
	1222-IA-04	0.92	<0.63	0.59	<2.7
	1222-IA-05	<0.59	<0.6	0.71	<3
	1222-IA-06	<0.62	<0.64	1.2	<3
	1222-IA-07	0.88	<0.6	1.3	<4.7
	1222-IA-08	1	1.9	--	<3
	1222-IA-09	1.2	0.77	1.2	<2.8
Sub-Slab Soil Gas	1222-SS-01	<29	<56	<57	<59
	1222-SS-02	30	<29	<11	13
	1222-SS-03	<1,400	<740	<910	<38
	1222-SS-04	<38	<27	<3.9	<27
	1222-SS-05	<58	<57	<25	110
	1222-SS-06	18,000	33,000	2,700	86,000
	1222-SS-07	56	<28	<55	<28
	1222-SS-08	47	<29	<37	<38
	1222-SS-09	<1,400	<1,400	<1,300	<2,800

Screening levels for indoor air are $2,200 \mu\text{g}/\text{m}^3$ (RIASL₁₂) and $6,600 \mu\text{g}/\text{m}^3$ (TSRIASL₁₂)
Screening levels for sub-slab soil gas are $72,000 \mu\text{g}/\text{m}^3$ (RIASL₁₂) and $210,000 \mu\text{g}/\text{m}^3$ (TSRIASL₁₂)

	RIASL12 Exceedance
	TSRIASL12 Exceedance

Summary of Results for Trichloroethene (TCE)

Sample Type	Sample ID	Measured Concentration ($\mu\text{g}/\text{m}^3$)			
		Apr. 2017	Nov. 2018	Feb. 2019	Aug. 2019
		E1	E2	E3	E4
Outdoor Air	1222-OA-01	<0.18	<0.17	<0.16	<0.18
Indoor Air	1222-IA-01	<0.18	<0.18	<0.17	<0.17
	1222-IA-02	<0.18	<0.18	0.22	<0.16
	1222-IA-03	<0.18	<0.19	<0.16	<0.18
	1222-IA-04	<0.19	<0.19	0.20	<0.16
	1222-IA-05	<0.18	<0.18	0.31	<0.18
	1222-IA-06	<0.19	<0.19	<0.18	<0.18
	1222-IA-07	<0.17	<0.18	<0.17	<0.29
	1222-IA-08	<0.19	<0.18	--	0.21
	1222-IA-09	<0.18	<0.19	<0.18	<0.17
Sub-Slab Soil Gas	1222-SS-01	<44	<86	<88	<90
	1222-SS-02	<43	<4	<17	<15
	1222-SS-03	<2,200	<1,100	<1,400	<59
	1222-SS-04	<58	<41	<5.9	<41
	1222-SS-05	180	160	79	130
	1222-SS-06	<440	440	<43	230
	1222-SS-07	<81	<44	<83	<43
	1222-SS-08	<28	<44	<57	<58
	1222-SS-09	<2,100	<2,100	<2,000	<4,200

Screening levels for indoor air are $4 \mu\text{g}/\text{m}^3$ (RIASL₁₂) and $12 \mu\text{g}/\text{m}^3$ (TSRIASL₁₂)
Screening levels for soil-gas are $130 \mu\text{g}/\text{m}^3$ (RIASL₁₂) and $400 \mu\text{g}/\text{m}^3$ (TSRIASL₁₂)

Summary of Results for 1,1,1-Trichloroethane (1,1,1-TCA)

Sample Type	Sample ID	Measured Concentration ($\mu\text{g}/\text{m}^3$)			
		Apr. 2017	Nov. 2018	Feb. 2019	Aug. 2019
		E1	E2	E3	E4
Outdoor Air	1222-OA-01	<0.19	<0.18	<0.16	<0.18
Indoor Air	1222-IA-01	<0.18	<0.19	<0.17	<0.18
	1222-IA-02	<0.18	<0.18	<0.18	<0.16
	1222-IA-03	<0.18	<0.19	<0.18	<0.18
	1222-IA-04	<0.19	<0.2	<0.16	<0.16
	1222-IA-05	<0.18	<0.19	<0.17	<0.19
	1222-IA-06	<0.19	<0.2	<0.16	<0.18
	1222-IA-07	<0.18	<0.18	<0.18	<0.29
	1222-IA-08	<0.19	<0.18	<0.18	<0.18
	1222-IA-09	<0.18	<0.19	<0.18	<0.17
Sub-Slab Soil Gas	1222-SS-01	60	310	310	330
	1222-SS-02	100	110	23	28
	1222-SS-03	<2,200	<1,100	<1,400	<60
	1222-SS-04	<58	50	<6	43
	1222-SS-05	1,500	1,800	650	1,500
	1222-SS-06	<450	<350	<44	300
	1222-SS-07	170	150	<84	130
	1222-SS-08	<29	<44	<58	<58
	1222-SS-09	<2,200	<2,200	<2,100	<4,300

Screening level for indoor air is $7,000 \mu\text{g}/\text{m}^3$ (RIASL₁₂/TSRIASL₁₂)
Screening levels for soil-gas are $230,000 \mu\text{g}/\text{m}^3$ (RIASL₁₂/TSRIASL₁₂)

	RIASL12 Exceedance
	TSRIASL12 Exceedance

EVALUATION OF VI DATA TRENDS

Data trends for Building 1222 are discussed below for both sub-slab soil gas and indoor air. When data exhibit a narrow range of variability, it is typical practice to express the range as a percentage (e.g., relative percent difference [RPD]). When data exhibit a large range of variability, however, it is more useful to express the range in orders of magnitude (i.e., factors of 10). This can be expressed mathematically as the log of the ratio of maximum/minimum values. If the values differ by a factor of 10, the log of the ratio is 1, if the values differ by a factor of 100, the log of the ratio is 2, and so on.

The variability across all locations over all sampling events is the total variability. This encompasses different types of variability, including spatial variability (i.e., how do the results vary from location to location), temporal variability (i.e., how do the results at a given location vary over time), and measurement variability. Measurement variability can be determined by evaluating results of duplicate or collocated samples and includes both sampling variability and analytical variability.

Sub-Slab Soil Gas Data Trends

Spatial Variability of Sub-Slab Soil Gas – The soil gas exhibit up to nearly four orders of magnitude of spatial variability. For example, sub-slab soil gas detections of CFC-11 vary from 1,800 to 170,000 $\mu\text{g}/\text{m}^3$ (log of max./min. = 2) across all nine locations for E3. Sub-slab detections of CFC-12 vary from 46 to 360,000 $\mu\text{g}/\text{m}^3$ (log max./min. = 3.9) across all six location for E3. The presence of CFC-11 and CFC-12 at these concentrations caused reporting limits for other analytes to increase and as a result, data are reported as ND across several of the sampling locations. 1,1,1-TCA was detected across the range of 60 to 1,500 $\mu\text{g}/\text{m}^3$ in E1 (log max./min. = 1.5). Based on this data, there is a relatively large amount of spatial variability in sub-slab soil gas given the size of the building and the number of sampling locations.

Temporal Variability of Soil Gas – The soil gas concentrations exhibit, at most, slightly more than one order of magnitude of temporal variability. For example, sub-slab soil gas concentrations of CFC-11 vary from 15,000 to 170,000 $\mu\text{g}/\text{m}^3$ at location 1222-SS-03 (log max/min = 1.4) and from 5,000 to 18,000 $\mu\text{g}/\text{m}^3$ at location 1222-SS-02 (log max/min = 0.56). For hexane, sub-slab soil gas concentrations of vary from 2,700 to 86,000 $\mu\text{g}/\text{m}^3$ at location 1222-SS-06 (log max/min = 1.5). For TCE, sub-slab soil gas concentrations vary from 79 to 180 $\mu\text{g}/\text{m}^3$ at location 1222-SS-05 (log max/min = 0.36). Based on this evaluation, there is a relatively low amount of temporal variability in sub-slab soil gas which is in-line with expectations. Overall, as expected, the amount of temporal variability is less than the amount of spatial variability.

Seasonal Confirmation Sampling Trend Analysis – No formal statistical tests were performed, but the data exhibits relatively consistent results between the seasons. This is demonstrated by the graph below, which shows the analytes discussed above at locations where they were detected at relatively high concentrations. Note that the y-axis is a log scale.

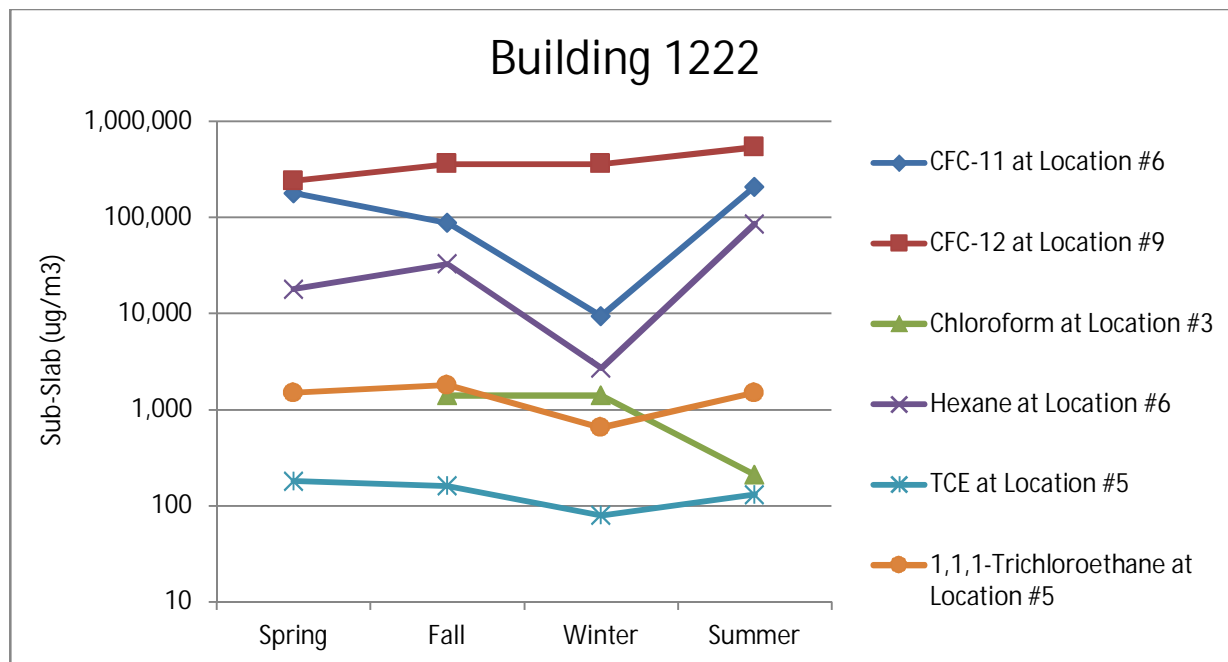

The data set was examined to see what the potential consequences would have been had only a single sampling event been performed. For CFC-11 and CFC-12, the highest sub-slab soil gas concentrations were collected during the summer (E4) and the lowest concentrations occurred during the winter (E3) or spring (E1), respectively. For hexane, the highest sub-slab concentration was also collected during the summer (E4) and the lowest concentration occurred during the winter (E3). Overall, the minimum and maximum values appear to be generally consistent between sampling events.

For CFC-12, a concentration of 240,000 $\mu\text{g}/\text{m}^3$ was measured during E1 and the highest concentration (540,000 $\mu\text{g}/\text{m}^3$) was measured during E4. If only E1 had been performed, a negative bias of 44% would have been introduced (i.e., the E4 result was 44% higher than the E1 result). For CFC-11, a value of 180,000 $\mu\text{g}/\text{m}^3$ was measured during E1 and the highest concentration (210,000 $\mu\text{g}/\text{m}^3$) was measured during E4. If only E1 had been performed, a negative bias of 17% would have been introduced. Therefore, implementing four seasonal confirmation sampling events provided insight regarding maximum concentration levels and the larger data set served to increase the confidence in the findings including demonstrating the consistency of the maximum reported results.

Indoor Air Data Trends

Spatial Variability of Indoor Air – Since indoor air results for TCE, EDC, 1,1,1-TCA, and hexane were predominantly ND, spatial variability was determined for CFC-11, CFC-12 and chloroform. CFC-11 had 100% detection frequency in indoor air across all sampling events. During E2, indoor air concentrations vary from 1.6 to 2.9 $\mu\text{g}/\text{m}^3$ (log max./min. = 0.68). The other events saw less variability. For CFC-12, the highest spatial variability occurred during E2 where indoor air concentrations vary from 2.2 to 3.4 $\mu\text{g}/\text{m}^3$ (log max./min. = 0.19). The highest spatial variability occurred for chloroform in E4 when concentrations ranged from 0.34 to 2.3 $\mu\text{g}/\text{m}^3$ (log max./min. = 0.83). The CFC-11, CFC-12, and chloroform data suggests the air within the building is well-mixed and influenced by outdoor air, since the concentrations of indoor and outdoor air are roughly equivalent, especially for CFC-11 and CFC-12.

Temporal Variability of Indoor Air – The indoor air has, at most, about one order of magnitude of temporal variability. For example, indoor air concentrations of CFC-11 at location 1222-IA-03 varied from 1.2 to 2.9 $\mu\text{g}/\text{m}^3$ (log of max./min. = 0.38). For chloroform at location 1222-IA-07, concentrations varied from 0.2 to 1.3 $\mu\text{g}/\text{m}^3$ (log max./min. = 0.81). For CFC-12, the temporal variability is less with most values

falling within about a factor of two. Overall, temporal variability across the four seasons sampled is relatively small.

Additional Analyses

Comparison of Sub-Slab Soil Gas and Indoor Air Data Sets – As expected, the sub-slab soil gas data exhibit greater spatial variability than the indoor air data set. The sub-slab soil gas also exhibits greater temporal variability than the indoor air data set, which is contrary to expectations. This suggests that there are not significant indoor sources of the AOIs or that emissions from any indoor air sources tend to be well distributed in this building.

Seasonal Effects – The sub-slab soil gas data exhibit relatively little variability from event to event. Maximum soil-gas values for CFC-11 and CFC-12 were detected during E4 (i.e., summer). The indoor air data set is predominantly ND values with very low variability, but the highest CFC-11 and CFC-12 values occurred during E2 (i.e., fall). Additionally, the indoor air concentrations detected for CFC-12 and CFC-11 were very similar to those observed in the outdoor air. The data do not support the hypothesis that wintertime should have the highest indoor air impacts.

Comparison of Attenuation Factors by Event – Attenuation factors were calculated for CFC-12 and CFC-11 based on maximum values since both analytes had a 100% detection frequency in sub-slab soil gas, as well as 100% detection frequency in indoor air during all four events. However, detections in outdoor air were very similar to detected indoor air concentrations. Therefore, the indoor air maximum concentration was corrected for contribution of outdoor air to indoor air (e.g., outdoor air detected concentration was subtracted from indoor air concentration). The calculated event-specific attenuation factors are shown in Table 1222-3.

Table 1222-3. Comparison of Building-Specific Attenuation Factors by Event

	E1 (Spring)	E2 (Fall)	E3 (Winter)	E4 (Summer)
Maximum Values				
CFC-12 in Sub-Slab Soil Gas ($\mu\text{g}/\text{m}^3$)	240,000	360,000	360,000	540,000
CFC-12 in Outdoor Air ($\mu\text{g}/\text{m}^3$)	2	2.1	2.1	1.9
CFC-12 in Indoor Air ($\mu\text{g}/\text{m}^3$)	2.1	3.4	2.4	2.4
CFC-12 in Indoor Air ($\mu\text{g}/\text{m}^3$) Corrected for Outdoor Air Contribution	0.1	1.3	0.3	0.5
Attenuation Factor	4.2E-07	3.6E-06	8.3E-07	9.3E-07

	E1 (Spring)	E2 (Fall)	E3 (Winter)	E4 (Summer)
Maximum Values				
CFC-11 in Sub-Slab Soil Gas ($\mu\text{g}/\text{m}^3$)	180,000	150,000	170,000	210,000
CFC-11 in Outdoor Air ($\mu\text{g}/\text{m}^3$)	1.1	1	1.2	1.2
CFC-11 in Indoor Air ($\mu\text{g}/\text{m}^3$)	1.3	2.9	2	1.9
CFC-11 in Indoor Air ($\mu\text{g}/\text{m}^3$) Corrected for Outdoor Air Contribution	0.2	1.9	0.8	0.7
Attenuation Factor	1.1E-06	1.3E-05	4.7E-07	3.3E-06

These serve as the best estimate of attenuation at this building. The results can vary from day to day due to differences in rates of vapor intrusion and rates of building ventilation. Overall, the most conservative estimate of a building-specific attenuation factor for Building 1222 is 1.3E-05 based on CFC-11 during E2.

Temporal Variability in Attenuation Factor – As shown in Table 1, there was about one order of magnitude of temporal variability in the calculated attenuation factors observed for CFC-12 and two orders of magnitude of temporal variability in the calculated attenuation factors observed for CFC-11.

To be as conservative as possible, the maximum values were used in calculating the attenuation factor for each event. All maximum sub-slab soil gas values for CFC-12 are from Sample Location 1222-SS-09 and all maximum indoor air values are from 1222-IA-03, except for E3 where the maximum was 1222-IA-02, though indoor air values were similar across events. The location of the maximum sub-slab soil gas values for CFC-11 were more variable (E1 = 1222-SS-06, E2 =1222-SS-05, E3 =1222-SS-03, and E4= 1222-SS-06). The maximum indoor air values for CFC-11 are also from 1222-IA-03, with the exception of E1, which was from 1222-IA-03, though indoor air results for CFC-11 were similar across all events. In general, the low spatial variability in indoor air results means that roughly comparable attenuation factors would be obtained whichever indoor air value was used in the calculations.

NON-DETECT EVALUATION

Twenty-eight analytes were ND analytes in sub-slab soil gas with reporting limits that exceed screening levels. Table 1222-4 presents the ND evaluation for those analytes in sub-slab soil gas with reporting limits that exceed the screening level. With one exception (EDB), all analytes listed in the table below have at least three samples where the reporting limits met the screening level. All ND RLs in sub-slab soil gas for EDB exceed screening levels for all events; however, during E4, 100% of the indoor air ND RLs for EDB met the screening level

Table 1222-4. Sub-Slab Soil Gas Analytes with Reporting Limits that Exceed Screening Levels Requiring No ND Evaluation

Analyte	Number of Samples	Detection Rate	Percent of Sub-Slab Soil Gas Detection Limits Exceeding Screening Levels (Range from E1-E4)	Status in IA
1,1,2,2-Tetrachloroethane	9	0%	56-67%	All IA RLs met Screening Levels
1,1,2-Trichloroethane	9	0%	78-100%	
1,1-Dichloroethane	9	22%	0-11%	
1,2-Dichloroethane	9	11%	11-33%	
1,2-Dichloropropane	9	0%	11-22%	
1,3-Dichlorobenzene	9	0%	11-33%	
1,4-Dichlorobenzene	9	0%	11-22%	
1,4-Dioxane	9	0%	11-33%	
2-Hexanone	9	0%	11-22%	
alpha-Chlorotoluene	9	0%	33-56%	
Benzene	9	0%	11-22%	
Bromodichloromethane	9	0%	22-33%	
Bromoform	9	0%	11-22%	
Bromomethane	9	0%	11-33%	
Carbon Tetrachloride	9	0%	11-22%	
Chloroform	9	0%	11-33%	
cis-1,2-Dichloroethene	9	0%	11-22%	
Cumene	9	0%	11-33%	
Dibromochloromethane	9	0%	22-33%	
Dibromomethane	9	0%	44-56%	
Ethyl Benzene	9	0%	0-22%	
Naphthalene	9	0%	56-100%	
Tetrachloroethene	9	56%	0-11%	
Trichloroethene	9	11%	11-33%	
Vinyl Chloride	9	0%	11-22%	

Table 1222-5. ND Evaluation for Sub-Slab Soil Gas Analytes with Reporting Limits that Exceed Screening Levels

Analyte	Number of Samples	Detection Rate	Sampling Event	Percent Exceed (ND RL) - MDEQ Project-Specific	# Samples RL met Screening Level	Status in IA
1,2,4-Trichlorobenzene	9	0%	E1	89%	1	14 samples out of 36 total samples had IA RLs > screening level
			E2	100%	0	
			E3	78%	2	
			E4	89%	1	
1,2-Dibromoethane (EDB)	9	0%	E1	100%	0	IA RLs for samples collected in E4 all met screening levels. All samples collected in E1 - E3 had IA RLs > screening levels
			E2	100%	0	
			E3	100%	0	
			E4	100%	0	
Hexachlorobutadiene	9	0%	E1	100%	0	IA RLs for samples collected in E4 all but one sample met screening levels. All samples collected in E1 - E3 had IA RLs > screening levels
			E2	100%	0	
			E3	78%	2	
			E4	89%	1	

WEIGHT-OF-EVIDENCE SUMMARY

Building 1222 was confirmed as a VI Path Forward Group 2 building due to its potential for VI based on sub-slab soil gas exceedances of the draft project-specific RIASL₁₂ and/or TSRIASL₁₂ for EDC, CFC-11, CFC-12, chloroform, hexane and TCE. However, after further investigation and evaluation, the following evidence supports the conclusion that VI is insignificant at Building 1222:

- No exceedances of draft project-specific screening levels in indoor air.
- The sub-slab soil gas data do not show any strong time dependence nor do the sub-slab data show any strong seasonal effects. The indoor air data also show minimal temporal variability. This evaluation confirms that the sub-slab soil gas and indoor air concentrations were relatively constant from season to season.
- The data do not support the hypothesis that wintertime should have the highest indoor air impacts. The highest sub-slab soil gas concentrations generally were measured in the spring and summer. Similarly, the highest indoor air concentrations were measured in the fall.
- As shown in the table below, the building-specific attenuation factor yields estimated indoor air concentration for EDB well below the screening level.

Parameters	EDB
Building-specific AF	1.3E-05
Maximum detected concentration in SSSG (1222-SS-09)	<6,100
Estimated Indoor Air Concentration	<0.079
Indoor Air ND RL at 1222-IA-04	<0.27
Indoor Air RIASL ₁₂	0.2

Based on the CSM for Building 1222, VI is an insignificant exposure pathway for current building utilization.

PATH FORWARD

Based on the evaluation of the four seasonal confirmation sampling events, the VI pathway continues to be insignificant for Building 1222 and the sub-slab soil gas results have demonstrated relatively stable concentrations and no evidence of increasing over time. Sufficient information exists to make a human exposure under control EI determination. However, while currently there is no evidence of potential VI, for future use, LTM is warranted and the building-specific Interim Monitoring Plan is discussed below.

Building-specific Interim Monitoring Plan

Dow will implement an interim monitoring plan at Building 1222 until a revised program or more permanent corrective action plan is developed for the site.

Indoor air will be monitored at location 1222-IA-03 and 1222-IA-06. These locations were selected for continued monitoring since it demonstrated the highest sub-slab soil gas results. Monitoring will be performed for CFC-11, CFC-12 and TCE. An outdoor air sample will also be collected at the time of each monitoring event. Interim monitoring will be performed semi-annually for a minimum of two years and monitoring results will undergo trend analysis. Monitoring will begin summer of 2020. If results continue to be consistent and below screening levels, monitoring will be conducted on an annual basis. If indoor air results are observed to be increasing, further evaluation will be performed, which may include collection of a sub-slab soil gas sample(s) and an increase in monitoring frequency. Results from each monitoring event will be reported in the annual CAIP. In the event an indoor air result(s) exceeds screening levels, EGLE will be provided a brief email notification. A collocated indoor air and sub-slab soil gas sample will be collected from that location within 45 days. If both sub-slab soil gas and indoor air results indicate that VI continues to be insignificant, monitoring will continue at an appropriate frequency. If both sub-slab soil gas and indoor air results indicate that VI is significant and confirm Group 4 conditions, the building will be moved to Group 4 for follow-up actions.

Dow may propose changes to the frequency or other aspects of this interim monitoring plan in the future based on an evaluation of the data, changes in building use or implementation of other corrective actions to address the potential VI pathway.

5.4 Zone 2 Phase 2 Evaluations

The Zone 2 Phase 2 buildings were initially evaluated in Section 5.3 in the 2018 CAIP (January 2019). A recent review of the site demolition list indicated that a Zone 2 Phase 2 Category 2 building (Building 1255) was listed for demolition. Therefore, this building has been recategorized and removed from VI sampling and evaluation. Zone 2 Phase 2 VI results and evaluations are presented for the buildings listed below in the following subsections:

- Section 5.4.1 Building 1255;
- Section 5.4.2 Building 304;
- Section 5.4.3 Building 499;
- Section 5.4.4 Building 593;
- Section 5.4.5 Building 826/494;
- Section 5.4.6 Building 921;
- Section 5.4.7 Building 923; and
- Section 5.4.8 Building 935.

5.4.1 VI Seasonal Confirmation Sampling Results Evaluation for Building 1255

INTRODUCTION

Building 1255 is located in the southeastern quadrant of the Midland Facility designated as Zone 2 (Figure 5.4.1-1). It is known as the EH&S Offices building. The initial evaluation was in Section 5.3.13 of the 2018 CAIP concluded that based on the indoor air results, the VI pathway at Building 1255 is an insignificant exposure pathway based on current use; however, based on a single correlated exceedance of the RIASL₁₂ for chloroform, Building 1255 was preliminarily identified as a Group 4B. Based on this preliminary grouping, as an interim response action, seasonal confirmation sampling was implemented and completed in 2019.

Building 1255	
Initial Sampling Event	Completed
E1	October/November 2017 (Fall)
E2	February 2019 (Winter)
E3	April 2019 (Spring)
E4	August 2019 (Summer)

Due to the rescreen effort in 2018, the first discussion for Building 1255 occurred during the Corrective Action Status conference call in October 2018. A follow-up email was sent in October 2018 that provided further details. Seasonal confirmation sampling was implemented for both sub-slab soil gas and indoor air and email updates were also provided in April and October 2019. As stated in the October 2019 email, the weight of evidence continues to support a Group 4A building. A Group 4A building has seasonal confirmation sample results that demonstrate a lack of correlated sub-slab soil gas and indoor air exceedances (RIASL₁₂ and/or TSRIASL₁₂) and other lines of evidence indicate that VI is insignificant and IA exceedances are likely due to work place chemical use.

Based on the evaluation of the four seasonal confirmation sampling events, the VI pathway continues to be insignificant. Sufficient information exists to make a human exposure under control EI determination.

SUB-SLAB SOIL GAS RESULTS EVALUATION

Sub-slab soil gas samples were collected from six locations from within the building. Indoor air samples were collected at six locations corresponding to the soil gas sample locations, along with an outdoor air sample from the main air intake. The sampling locations are shown on Figure 5.4.1-2. Summary statistics and screening comparison results are presented for sub-slab soil gas on Table 5.4.1-A and indoor and outdoor air on Table 5.4.1-B. The analytical data is presented in Appendix A. Field sampling forms are provided in Appendix B. A figure showing results for each sample location is provided for chloroform since this analyte has exceedances in both sub-slab soil gas and indoor air (Figure 1255-1). Table 1255-1 presents the sub-slab soil gas results that exceed the draft project-specific screening levels.

Table 1255-1. Summary of Sub-Slab Soil Gas Exceedances for Building 1255

Analyte	Detection Frequency	Measured Range of Detects ($\mu\text{g}/\text{m}^3$)	% Detects > Screening Level	Screening Level* ($\mu\text{g}/\text{m}^3$)
CFC-12 (1)	100%	53,000 - 1,300,000	100%	34,000
CFC-12 (2)	100%	18,000 - 800,000	83%	34,000
CFC -12 (3)	100%	13,000 - 210,000	67%	34,000
CFC-12 (4)	100%	7,400 - 210,000	50%	34,000
Chloroform (1)	17%	1,200	17%	170
Chloroform (2)	0%	ND	0%	170
Chloroform (3)	33%	150 - 410	17%	170
Chloroform (4)	33%	95 - 100	0%	170

*Screening level provided is the draft project-specific RIASL₁₂.

Table 1255-2 summarizes the indoor air results relative to the sub-slab soil gas exceedances, since VI only potentially occurs if the analyte is present in both sub-slab soil gas and indoor air. Therefore, the table below provides the analyte detected above applicable screening levels in sub-slab soil gas as well as the corresponding indoor air sample result. The outdoor air sample result is also provided to determine if the analytes were present in indoor air due to migration from outdoor air.

Table 1255-2. Vapor Intrusion Evaluation for Building 1255

Analyte	Indoor Air Detection Frequency	Indoor Air Measured Range ($\mu\text{g}/\text{m}^3$)	Indoor Air Screening Level* ($\mu\text{g}/\text{m}^3$)	Outdoor Air Result ($\mu\text{g}/\text{m}^3$)
CFC-12 (1)	100%	29 - 52	1,020	2.3
CFC-12 (2)	100%	32 - 38	1,020	1.9
CFC -12 (3)	100%	16 - 78	1,020	2
CFC-12 (4)	100%	72 - 74	1,020	2
Chloroform (1)	100%	1 - 5.3	5.2	0.33
Chloroform (2)	100%	1.2	5.2	ND
Chloroform (3)	100%	1.2 - 2.2	5.2	ND
Chloroform (4)	100%	8.5 - 9	5.2	ND

*Screening level provided is the draft project-specific RIASL₁₂.

All indoor air results for Building 1255, with the exception of chloroform in E1 and E4, are below screening levels. There was a slight exceedance of chloroform in indoor air during E1: however, if the contribution for outdoor air is taken in account, the indoor air result does not exceed the RIASL₁₂. During E2 and E3 all indoor air results for chloroform were below screening levels. During E4, the chloroform results for all six indoor air samples were greater than the RIASL₁₂ but below the TSRIASL₁₂. The maximum detected indoor air concentration was 9 $\mu\text{g}/\text{m}^3$ (RIASL₁₂ = 5.2 $\mu\text{g}/\text{m}^3$; TSRIASL₁₂ = 52 $\mu\text{g}/\text{m}^3$). There were two

chloroform detections in sub-slab soil gas that were below the RIASL₁₂ and the maximum detected concentration was 100 µg/m³ (RIASL₁₂ = 170 µg/m³). The other four sub-slab soil gas results were ND, two of which had ND RLs below the TSRIASL₁₂ and two that slightly exceed the TSRIASL₁₂. The maximum sub-slab soil gas ND RL was 1,900 µg/m³ (TSRIASL₁₂ = 1,700 µg/m³). Figure 5.4.1-3 shows the chloroform results for each sample location.

VAPOR INTRUSION CONCEPTUAL SITE MODEL

VI is an exposure pathway that results from the migration of volatilized chemicals from the subsurface to indoor air in overlying occupied buildings. A source, migration route and a human receptor must be present for the VI pathway to be complete. The focus of this building specific investigation is to evaluate the potential VI exposure pathway for employees and contractors at Building 1255. The CSM is illustrated in Figure 5.4.1-4.

Building 1255 is located in the southeastern quadrant of the Midland Facility and is known as the EH&S Offices building. The present structure was built approximately 25-35 years ago between 1982-1993 per building occupants and aerial photography. The 8,163 ft² building is a single-story slab-on-grade construction with no basement. The building is predominantly office space with locker rooms and a kitchen. The ground cover around the building is predominantly asphalt or concrete; however, some flower beds/boxes are located on the west side of the building.

The building is heated via hot air circulation and is cooled via central AC. The locker rooms also have ventilation fans and the outside air intake is located on the eastern side of the building. There are washer/dryers available in the building; however, a contracted laundry service is predominantly used for any uniforms. The building has no garage or bay doors.

Approximately 22-30 people work in this building from 8AM-5PM for five days a week (Monday through Friday). Until building use changes to a more permanent usage, the typical parameters for non-residential exposures are assumed to apply but likely overestimate exposure for the personnel stationed at this building (i.e., 40 hours/week, 50 weeks/year exposure).

No PID readings were observed in the ambient air or any drain features noted during the survey.

A building survey completed before the initial sampling event. Drains and other openings were screened with a PID and no soil gas entry points were identified. No PID readings were observed in the ambient air or any drain features noted during the survey. A chemical inventory was completed during the building survey that identified cleaners, insect spray, and spray paint.

EVALUATION OF SEASONAL CONFIRMATION SAMPLING EVENTS

Four seasonal sampling events and one interim monitoring event have been completed at Building 1255. The sampling events encompass more than one year of time and include sampling during each season of the year. The results from the four seasonal confirmation sampling events were evaluated with respect to spatial variability, temporal variability, and seasonal trend analysis.

Building specific attenuation factors (α) were calculated and compared between events to evaluate temporal variability and determine the best estimate of a building-specific attenuation factor. This evaluation serves to confirm that the existing study design is appropriate, and also provides insight for the determination of the path forward for this building.

This evaluation focused on any analytes detected in the sub-slab soil gas samples that met the criterion for inclusion in one or more of the following categories:

- a) Analytes detected in sub-slab soil-gas at concentrations that exceeded draft project-specific screening levels;

- b) Analytes detected in sub-slab soil-gas at concentrations of 1,000 $\mu\text{g}/\text{m}^3$ or greater in one or more samples. Data for analytes detected above 1,000 $\mu\text{g}/\text{m}^3$ should provide the clearest signal and be the simplest to interpret when assessing data trends. The same data trends observed for these analytes are expected to apply to other similar analytes present at lower concentrations; and
- c) PCE and TCE. These two analytes are of particular interest for many VI evaluations at industrial sites.

For this building, the only analytes detected in the sub-slab soil gas at concentrations above the draft project-specific screening levels were CFC-12, and chloroform. Only one additional analyte had a detected concentration $\geq 1,000 \mu\text{g}/\text{m}^3$, styrene; however, due to minimal detections throughout sampling, it was excluded from additional evaluation, as was PCE and TCE. Sample results for CFC-12 and chloroform are provided in the following data tables below:

Summary of Results for Chlorofluorocarbon (CFC-12)

Sample Type	Sample ID	Measured Concentration ($\mu\text{g}/\text{m}^3$)			
		Oct./Nov. 2017	Feb. 2019	Apr. 2019	Aug. 2019
		E1	E2	E3	E4
Outdoor Air	1255-OA-01	2.3	1.9	2	2
Indoor Air	1255-IA-01	49	34	78	72
	1255-IA-02	48	32	23	73
	1255-IA-03	49	33	30	73
	1255-IA-04	29	32	19	74
	1255-IA-05	48	32	16	73
	1255-IA-06	52	38	34	73
Sub-Slab Soil Gas	1255-SS-01	1,300,000	18,000	44,000	29,000
	1255-SS-02	1,000,000	82,000	140,000	69,000
	1255-SS-03	320,000	140,000	13,000	7,400
	1255-SS-04	440,000	130,000	24,000	13,000
	1255-IA-05	53,000	220,000	62,000	210,000
	1255-IA-06	750,000	800,000	210,000	190,000

Screening levels for indoor air are 1,020 $\mu\text{g}/\text{m}^3$ (RIASL₁₂)

Screening levels for soil-gas are 34,000 $\mu\text{g}/\text{m}^3$ (RIASL₁₂)

	RIASL12 Exceedance
	TSRIASL12 Exceedance

Summary of Results for Chloroform

Sample Type	Sample ID	Measured Concentration ($\mu\text{g}/\text{m}^3$)			
		Oct./Nov. 2017	Feb. 2019	Apr. 2019	Aug. 2019
		E1	E2	E3	E4
Outdoor Air	1255-OA-01	0.33	<0.16	<0.16	<0.18
Indoor Air	1255-IA-01	4.4	1.2	1.5	8.6
	1255-IA-02	5.1	1.2	1.3	8.8
	1255-IA-03	5	1.2	1.3	8.9
	1255-IA-04	1	1.2	1.5	9
	1255-IA-05	5.3	1.2	2.2	8.5
	1255-IA-06	5.1	1.2	1.2	9
Sub-Slab Soil Gas	1255-SS-01	<4,300	<220	<380	<300
	1255-SS-02	<2,800	<720	<980	<680
	1255-SS-03	<880	<910	150	100
	1255-SS-04	<2,400	<850	<280	95
	1255-IA-05	1,200	<1,800	410	<1,900
	1255-IA-06	<1,900	<1,700	<1,900	<1,800

Screening levels for indoor air are $5.2 \mu\text{g}/\text{m}^3$ (RIASL₁₂) and $52 \mu\text{g}/\text{m}^3$ (TSRIASL₁₂)
Screening levels for soil-gas are $170 \mu\text{g}/\text{m}^3$ (RIASL₁₂) and $1,700 \mu\text{g}/\text{m}^3$ (TSRIASL₁₂)

	RIASL12 Exceedance
	TSRIASL12 Exceedance

EVALUATION OF VI DATA TRENDS

Data trends for Building 1255 are discussed below for both sub-slab soil gas and indoor air. When data exhibit a narrow range of variability, it is typical practice to express the range as a percentage (e.g., relative percent difference [RPD]). When data exhibit a large range of variability, however, it is more useful to express the range in orders of magnitude (i.e., factors of 10). This can be expressed mathematically as the log of the ratio of maximum/minimum values. If the values differ by a factor of 10, the log of the ratio is 1, if the values differ by a factor of 100, the log of the ratio is 2, and so on.

The variability across all locations over all sampling events is the total variability. This encompasses different types of variability, including spatial variability (i.e., how do the results vary from location to location), temporal variability (i.e., how do the results at a given location vary over time), and measurement variability. Measurement variability can be determined by evaluating results of duplicate or collocated samples and includes both sampling variability and analytical variability.

Sub-Slab Soil Gas Data Trends

Spatial Variability of Sub-Slab Soil Gas – The soil gas exhibit less than two orders of magnitude of spatial variability. For example, sub-slab soil gas detections of CFC-12 vary from 53,000 to 1,300,000 $\mu\text{g}/\text{m}^3$ (log of max./min. = 1.4) across all six locations for E1. Other events for CFC-12 have similar variability. Chloroform was only detected in a handful of sub-slab soil gas samples and detections of chloroform range from 150 to 410 $\mu\text{g}/\text{m}^3$ (log of max./min. = 0.44), across all detected locations for E3.

Temporal Variability of Soil Gas – The soil gas concentrations exhibit less than two orders of magnitude of temporal variability. For CFC-12, sub-slab soil gas concentrations of vary from 18,000 to 1,300,000 $\mu\text{g}/\text{m}^3$ at location 1255-SS-01 (log max/min = 1.9). CFC-12 at location 1255-SS-02 varies from 69,000 to 1,000,000 $\mu\text{g}/\text{m}^3$ (log max/min = 1.2). For chloroform, sub-slab soil gas detected concentrations vary from 100 to 150 $\mu\text{g}/\text{m}^3$ at location 1255-SS-03 (log max/min = 0.18). Sub-slab soil gas concentrations of chloroform vary from 410 to 1,200 $\mu\text{g}/\text{m}^3$ at location 1255-SS-05 (log max/min = 0.47). Overall, temporal variability is similar to spatial variability, which is contrary to expectations.

Seasonal Confirmation Sampling Trend Analysis – No formal statistical tests were performed, but the data exhibits relatively consistent results between the seasons. This is demonstrated by the graph below, which shows the two analytes selected above at locations where they were detected at relatively high concentrations. Chloroform had relatively few detected results and the detects are represented on the graph below. Note that the y-axis is a log scale.

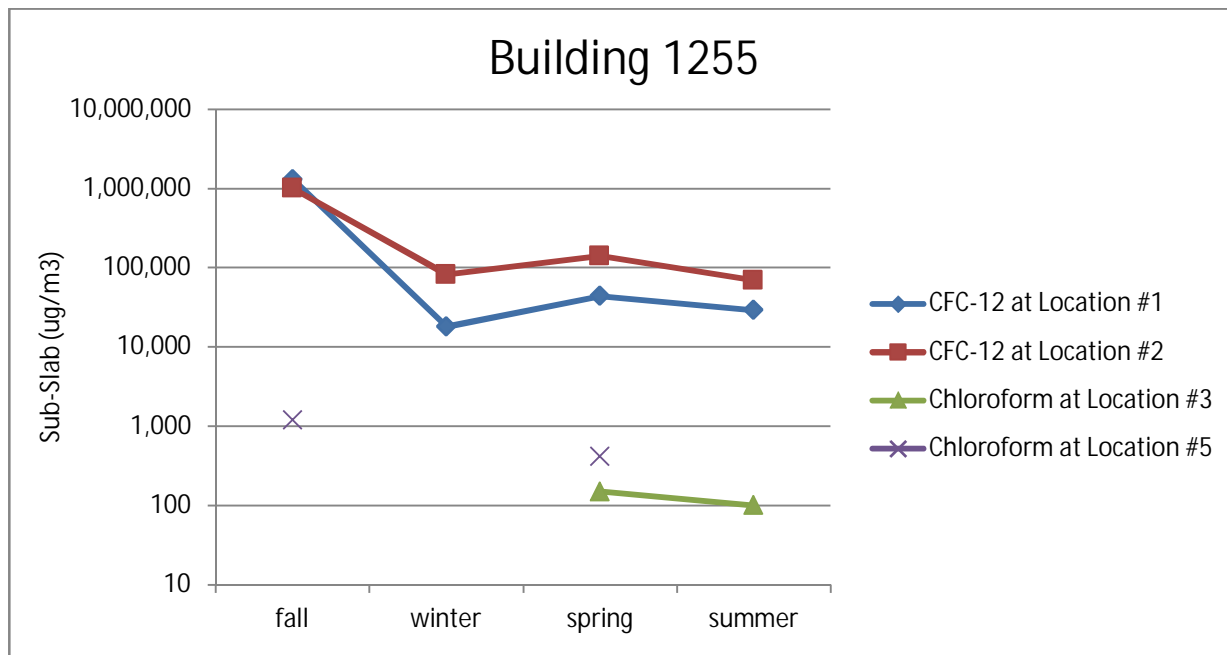

The data set was examined to see what the potential consequences would have been had only a single sampling event been performed. CFC-12, the highest sub-slab soil gas concentrations were collected during the fall (E1) and the lowest concentrations occurred during the summer (E4). For chloroform, the highest sub-slab concentration was also collected during the fall (E1) and the lowest concentration occurred during the summer (E4). Overall, the minimum and maximum values appear to be consistent between sampling events.

Since both analytes had the highest results occur during E1, there was no negative bias introduced by results from other seasonal sampling events. Therefore, implementing four seasonal confirmation sampling events provided only limited insight regarding maximum concentration levels, but the larger data set served to increase the confidence in the findings.

Indoor Air Data Trends

Spatial Variability of Indoor Air – The indoor air exhibit less than one order of magnitude of spatial variability. CFC-12 and chloroform had 100% detection frequency in indoor air across all sampling events. For CFC-12 during E3, indoor air concentrations vary from 16 to 78 $\mu\text{g}/\text{m}^3$ (log max./min. = 0.69). The other events saw much less variability. For chloroform, the highest spatial variability occurred during E1 where indoor air concentrations vary from 1 to 5.3 $\mu\text{g}/\text{m}^3$ (log max./min. = 0.72). The other events saw much less variability. The data suggests the air within the building is well-mixed, especially for chloroform.

Temporal Variability of Indoor Air – The indoor air has, at most, one order of magnitude of temporal variability. For example, indoor air concentrations of CFC-12 at location 1255-IA-05 varied from 16 to 73 $\mu\text{g}/\text{m}^3$ (log of max./min. = 0.66). Temporal variability for all other locations for CFC-12 were less than location 1255-IA-05. For chloroform at location 1255-IA-04, concentrations varied from 1 to 9 $\mu\text{g}/\text{m}^3$ (log

max./min. = 0.95). Variability at all other locations were less than but similar to 1255-IA-04. Overall, temporal variability across the four seasons sampled is relatively small.

Additional Analyses

Comparison of Sub-Slab Soil Gas and Indoor Air Data Sets – As expected, the sub-slab soil gas data exhibit greater spatial variability than the indoor air data set. The sub-slab soil gas also exhibits greater temporal variability than the indoor air data set, which is contrary to expectations.

Seasonal Effects – The sub-slab soil gas data exhibit some variability from event to event. Maximum sub-slab soil gas results for CFC-12 and chloroform occurred in E1 (fall). Maximum indoor air values for CFC-12 occurred in E3 (spring) and maximum detections for chloroform occurred in E4 (summer). The data does not support the hypothesis that wintertime should have the highest indoor air impacts.

Comparison of Attenuation Factors by Event – Attenuation factors were calculated for CFC-12 based on maximum values. The indoor air maximum concentration was corrected for contribution of outdoor air to indoor air (e.g., outdoor air detected concentration was subtracted from indoor air concentration). The calculated event-specific attenuation factors are shown in Tables 1255-3.

Table 1255-3. Comparison of Building-Specific Attenuation Factors for CFC-12 by Event

	E1 (Fall)	E2 (Winter)	E3 (Spring)	E4 (Summer)
Maximum Values				
CFC-12 in Sub-Slab Soil Gas ($\mu\text{g}/\text{m}^3$)	1,300,000	800,000	210,000	210,000
CFC-12 in Outdoor Air ($\mu\text{g}/\text{m}^3$)	2.3	1.9	2	2
CFC-12 in Indoor Air ($\mu\text{g}/\text{m}^3$)	52	38	78	74
CFC-12 in Indoor Air ($\mu\text{g}/\text{m}^3$) Corrected for Outdoor Air Contribution	49.7	36.1	76	72
Attenuation Factor	3.8E-05	4.5E-05	3.6E-04	3.4E-04

These serve as the best estimates of attenuation at this building. The results can vary from day to day due to differences in rates of vapor intrusion and rates of building ventilation. Overall, the most conservative estimate of a building-specific attenuation factor for Building 1255 is 3.4E-04 based on CFC-12 during E4.

Temporal Variability in Attenuation Factor – As shown in Table 1255-3, there was about one order of magnitude of temporal variability in the calculated attenuation factors observed for CFC-12 between the four sampling events. To be as conservative as possible, the maximum values were used in calculating the attenuation factor for each event. The sampling location with the maximum value per event varied. In general, the low spatial variability in indoor air results means that roughly comparable attenuation factors would be obtained whichever indoor air value was used in the calculations.

NON-DETECT EVALUATION

Table 1255-4 below lists the analytes in sub-slab soil gas that have ND RLs greater than the screening levels. The table also includes the indoor air results for each of the analytes. If a sub-slab soil gas analyte has ND RL exceedances, but all results and ND RLs in indoor air are below the screening levels, no further evaluation is warranted. If an analyte was identified as an AOI in sub-slab soil gas (detected results > screening level), it is excluded from the ND evaluation. Also, if an ND analyte has a 0% detection frequency for all sampling events and all ND RLs met the screening level during at least one event, no further ND evaluation is warranted.

Table 1255-4. Non-Detect Evaluation for Building 1255

Soil Gas Analytes with ND RL > SL	Indoor Air Result Summary
1,1,2,2-Tetrachloroethane	0% Detection Frequency, All ND RLs < RIASL ₁₂
1,1,2-Trichloroethane	0% Detection Frequency, All ND RLs < RIASL ₁₂
1,1-Dichloroethane	0% Detection Frequency, All ND RLs < RIASL ₁₂
1,2,4-Trichlorobenzene	0% Detection Frequency, All ND RLs < TSRIASL ₁₂
1,2-Dibromoethane (EDB)	0% Detection Frequency, All ND RLs > RIASL ₁₂
1,2-Dichloroethane	0% Detection Frequency, All ND RLs < RIASL ₁₂
1,2-Dichloropropane	0% Detection Frequency, All ND RLs < RIASL ₁₂
1,3-Dichlorobenzene	0% Detection Frequency, All ND RLs < RIASL ₁₂
1,4-Dichlorobenzene	0% Detection Frequency, All ND RLs < RIASL ₁₂
1,4-Dioxane	0% Detection Frequency, All ND RLs < RIASL ₁₂
2-Hexanone	0% Detection Frequency, All ND RLs < RIASL ₁₂
alpha-Chlorotoluene	0% Detection Frequency, All ND RLs < RIASL ₁₂
Benzene	0% Detection Frequency, All ND RLs < RIASL ₁₂
Bromodichloromethane	0% Detection Frequency, All ND RLs < RIASL ₁₂
Bromoform	0% Detection Frequency, All ND RLs < RIASL ₁₂
Bromomethane	0% Detection Frequency, All ND RLs < RIASL ₁₂
Carbon Tetrachloride	0% Detection Frequency, All ND RLs < RIASL ₁₂
Chloromethane	0% Detection Frequency, All ND RLs < RIASL ₁₂
cis-1,2-Dichloroethene	0% Detection Frequency, All ND RLs < RIASL ₁₂
Cumene	0% Detection Frequency, All ND RLs < RIASL ₁₂
Dibromochloromethane	0% Detection Frequency, All ND RLs < RIASL ₁₂
Dibromomethane	0% Detection Frequency, All ND RLs < RIASL ₁₂
Ethylbenzene	0% Detection Frequency, All ND RLs < RIASL ₁₂
Hexachlorobutadiene (HCBD)	0% Detection Frequency, All ND RLs > RIASL ₁₂
Naphthalene	0% Detection Frequency, All ND RLs < RIASL ₁₂
Tetrachloroethene	0% Detection Frequency, All ND RLs < RIASL ₁₂
Trichloroethene	0% Detection Frequency, All ND RLs < RIASL ₁₂
Vinyl chloride	0% Detection Frequency, All ND RLs < RIASL ₁₂

WEIGHT-OF-EVIDENCE SUMMARY

Building 1255 was confirmed as a VI Path Forward Group 4A building due to its potential for VI based on sub-slab soil gas exceedances of the draft project-specific RIASL₁₂ and/or TSRIASL₁₂ for CFC-12 and chloroform. However, after further investigation and evaluation, the following evidence supports the conclusion that VI is insignificant at Building 1255:

- No exceedances of draft project-specific screening levels in indoor air.
- The sub-slab soil gas data do not show any strong time dependence nor do the data show any strong seasonal effects.
- The data do not support the hypothesis that wintertime should have the highest indoor air impacts. The highest sub-slab soil gas concentrations generally were measured in the spring and summer. Similarly, the highest indoor air concentrations were measured in the fall.
- The indoor air data show relatively little spatial variability, despite the greater spatial variability in the sub-slab soil gas values. This evaluation confirms that the sub-slab soil gas and indoor air concentrations were relatively constant from season to season.
- As shown in the table below for chloroform, the building-specific attenuation factor yields an estimated indoor air concentration for the maximum ND RL in sub-slab soil gas during E4 that is less than the indoor air RIASL₁₂.

Parameters	Chloroform ($\mu\text{g}/\text{m}^3$)
Building-specific AF	3.4E-04
Maximum ND reporting limit in SSSG	<1,900
Estimated Indoor Air Concentration	0.65
Indoor Air ND RL	<9
Indoor Air RIASL ₁₂	5.2

Based on the CSM for Building 1255, VI is an insignificant exposure pathway for current building utilization.

PATH FORWARD

Based on the evaluation of the four seasonal confirmation sampling events and the results of the further investigation, the VI pathway continues to be insignificant for Building 1255. Weight of evidence based on seasonal confirmation sampling, as documented in email notifications provided to EGLE throughout 2019, supports Building 1255 as a Group 4A building, which is defined as: Building seasonal confirmation sample results demonstrate a lack of correlated sub-slab soil gas and indoor air exceedances (RIASL₁₂ and/or TSRIASL₁₂) and other lines of evidence indicate VI is insignificant and IA exceedances are likely due to work place chemical use. The sub-slab soil gas results have demonstrated relatively stable concentrations and no evidence of increasing over time. Furthermore, chloroform is ubiquitous in indoor air and often found in soil gas samples. Chloroform is one of the trihalomethanes produced by chlorination of water supplies. It has long been known that chloroform and other VOCs in tap water can be emitted into indoor air (McKone, 1987). Washing machines and kitchen sinks also may be significant sources (Howard and Corsi, 1998)(Howard and Corsi, 1996).

Sufficient information exists to make a human exposure under control EI determination. However, while currently there is no evidence of potential VI, for future use, LTM is warranted and the building-specific Interim Monitoring Plan is discussed below.

Building-specific Interim Monitoring Plan

Dow presented an interim monitoring plan for Building 1255 during the October 2019 Corrective Action status meeting. Dow will implement the interim monitoring plan at Building 1255 until a revised program or more permanent corrective action plan is developed for the site.

Indoor air will be monitored at location 1255-IA-01 and 1255-IA-06. These locations were selected for continued monitoring since it demonstrated the highest sub-slab soil gas results. Monitoring will be performed for CFC-12 and chloroform. An outdoor air sample will also be collected at the time of each monitoring event. Interim monitoring will be performed semi-annually for a minimum of two years and monitoring results will undergo trend analysis. Monitoring will begin summer of 2020. If results continue to be consistent and below screening levels, monitoring will be conducted on an annual basis. If indoor air results are observed to be increasing, further evaluation will be performed, which may include collection of a sub-slab soil gas sample(s) and an increase in monitoring frequency. Results from each monitoring event will be reported in the annual CAIP. In the event an indoor air result(s) exceeds screening levels, EGLE will be provided a brief email notification. A collocated indoor air and sub-slab soil gas sample will be collected from that location within 45 days. If both sub-slab soil gas and indoor air results indicate that VI continues to be insignificant, monitoring will continue at an appropriate frequency. If both sub-slab soil gas and indoor air results indicate that VI is significant and confirm Group 4 conditions, the building will be moved to Group 4 for follow-up actions.

Dow may propose changes to the frequency or other aspects of this interim monitoring plan in the future based on an evaluation of the data, changes in building use or implementation of other corrective actions to address the potential VI pathway.



Figure 1255-1

Chloroform	Soil Gas	Indoor Air
	ug/m ³	ug/m ³
Event 1	ND (440)	5
Event 2	910	1.2
Event 3	150	1.3
Event 4	100	8.9

Chloroform	Soil Gas	Indoor Air
	ug/m ³	ug/m ³
Event 1	ND (1,400)	5.1
Event 2	720	1.2
Event 3	ND (980)	1.3
Event 4	ND (680)	8.8

Chloroform	Soil Gas	Indoor Air
	ug/m ³	ug/m ³
Event 1	ND (950)	5.1
Event 2	1,700	1.2
Event 3	ND (1,900)	1.2
Event 4	ND (1,800)	9

Chloroform	Soil Gas	Indoor Air
	ug/m ³	ug/m ³
Event 1	ND (1,200)	1
Event 2	850	1.2
Event 3	ND (280)	1.5
Event 4	95	9

Chloroform	Soil Gas	Indoor Air
	ug/m ³	ug/m ³
Event 1	1,200	5.3
Event 2	1,800	1.2
Event 3	410	2.2
Event 4	ND (1,900)	8.5

Chloroform	Soil Gas	Indoor Air
	ug/m ³	ug/m ³
Event 1	ND (2,150)	4.4
Event 2	220	1.2
Event 3	ND (380)	1.5
Event 4	ND (300)	8.6

Legend

⊗ 1255-## Sub-slab/Indoor Air Location

Exceeds RIASL₁₂ Only

Exceeds TSRIASL₁₂

Exceeds Dow OEL

Media	COC	RIASL ₁₂	TSRIASL ₁₂	OEL
Soil Gas	Chloroform	170	1,700	--
Indoor Air	Chloroform	5.2	52	9,760



Notes:

All units ug/m³

Initial Sampling Event (1) = October 2017

Seasonal Confirmation Sampling Event 2 = February 2019

Seasonal Confirmation Sampling Event 3 = April 2019

Seasonal Confirmation Sampling Event 4 = August 2019

Outdoor air sample collected from near intake located on E side of building near Door 3.

Chloroform	Outdoor Air Sample
	ug/m ³
Event 1	0.33
Event 2	ND (0.08)
Event 3	ND (0.16)
Event 4	ND (0.18)

Sub-slab Soil Gas and Indoor Air Results for Chloroform Zone 2 Phase 2 Sampling Events 1 - 4 Building 1255

5.4.2 VI Seasonal Confirmation Sampling Results Evaluation for Building 304

INTRODUCTION

Building 304 is located in the southwestern quadrant of the Midland facility in Zone 2 and is known as the Dow Automotive and Brake Fluids Building (Figure 5.4.2-1). The initial evaluation in the 2018 CAIP concluded that the VI pathway at Building 304 is an insignificant exposure pathway based on current use; however, based on the sub-slab soil gas results and given the potential for future VI, Building 304 has been placed in VI Path Forward Building Group 4A, as lines of evidence indicate that VI is insignificant and the single indoor air exceedance of TCE during E1 was likely due to workplace chemical use. Seasonal confirmation sampling was conducted.

The results of the first three seasonal confirmation sampling events (E1, E2 and E3) were evaluated in Section 5.3.1 of the 2018 CAIP. Since that time, the E4 sampling event was completed and the results of all four seasonal events are included in this evaluation.

Building 304	
Initial Sampling Event	Completed
E1	November 2017 (Fall)
Seasonal Sampling Event	Completed
E2	March 2018 (Spring)
E3	August 2018 (Summer)
E4	February 2019 (Winter)

Based on the evaluation of the four seasonal confirmation sampling events and one interim monitoring event, the VI pathway continues to be insignificant. Sufficient information exists to make a human exposure under control EI determination.

SUB-SLAB SOIL GAS RESULTS EVALUATION

Sub-slab soil gas samples were collected from 11 locations from within the building. Indoor air samples were collected at 11 locations corresponding to the soil gas sample locations, along with an outdoor air sample from the main air intake. The sampling locations are shown on Figure 5.4.2-2. Summary statistics and screening comparison results are presented for sub-slab soil gas on Table 5.4.2-A and indoor and outdoor air on Table 5.4.2-B. The analytical data is presented in Appendix A. Field sampling forms are provided in Appendix B. A figure showing results for each sample location per event is provided for TCE since this analyte has exceedances in both sub-slab soil gas and indoor air (Figure 304-1). Table 304-1 presents the sub-slab soil gas results from seasonal confirmation sampling that exceed the draft project-specific screening levels.

Table 304-1. Summary of Sub-Slab Soil Gas Exceedances for Building 304

Analyte (Sampling Event)	Detection Frequency	Measured Range of Detects ($\mu\text{g}/\text{m}^3$)	% Detections > Screening Level	Screening Level* ($\mu\text{g}/\text{m}^3$)
1,1,2-Trichloroethane (1)	0%	ND	0%	20
1,1,2-Trichloroethane (2)	9%	42	9%	20
1,1,2-Trichloroethane (3)	0%	ND	0%	20
1,1,2-Trichloroethane (4)	0%	ND	0%	20
1,2-Dichloroethane (1)	73%	12 - 4,800	45%	150
1,2-Dichloroethane (2)	55%	30 - 3,800	45%	150
1,2-Dichloroethane (3)	55%	64 - 5,000	45%	150
1,2-Dichloroethane (4)	45%	160 - 3,500	45%	150

**Table 304-1. Summary of Sub-Slab Soil Gas Exceedances for Building 304
(Continued)**

Analyte (Sampling Event)	Detection Frequency	Measured Range of Detects ($\mu\text{g}/\text{m}^3$)	% Detections > Screening Level	Screening Level* ($\mu\text{g}/\text{m}^3$)
1,2-Dichloropropane (1)	82%	13 - 6,300	55%	410
1,2-Dichloropropane (2)	82%	7.7 - 6,100	55%	410
1,2-Dichloropropane (3)	55%	1,200 - 7,400	55%	410
1,2-Dichloropropane (4)	55%	580 - 4,800	55%	410
Carbon Tetrachloride (1)	100%	54 - 2,300	55%	710
Carbon Tetrachloride (2)	100%	21 - 2,100	36%	710
Carbon Tetrachloride (3)	100%	22 - 2,900	55%	710
Carbon Tetrachloride (4)	100%	14 - 1,800	27%	710
Chloroform (1)	100%	12 - 1,400	55%	170
Chloroform (2)	100%	12 - 1,700	64%	170
Chloroform (3)	91%	5.2 - 2,200	55%	170
Chloroform (4)	82%	7.1 - 1,400	55%	170
cis-1,2-Dichloroethene (1)	55%	9.6 - 1,200	9%	820
cis-1,2-Dichloroethene (2)	55%	13 - 660	0%	820
cis-1,2-Dichloroethene (3)	36%	4.7 - 420	0%	820
cis-1,2-Dichloroethene (4)	36%	57 - 310	0%	820
Dibromochloromethane (1)	0%	ND	0%	170
Dibromochloromethane (2)	0%	ND	0%	170
Dibromochloromethane (3)	9%	190	9%	170
Dibromochloromethane (4)	0%	ND	0%	170
Ethylbenzene (1)	36%	6 - 2,000	9%	1,600
Ethylbenzene (2)	18%	9.9 - 1,800	9%	1,600
Ethylbenzene (3)	18%	4.4 - 3,400	9%	1,600
Ethylbenzene (4)	9%	110	0%	1,600
Tetrachloroethene (1)	100%	2,600 - 140,000	91%	2,700
Tetrachloroethene (2)	100%	1,400 - 120,000	91%	2,700
Tetrachloroethene (3)	100%	960 - 160,000	82%	2,700
Tetrachloroethene (4)	100%	1,100 - 120,000	82%	2,700
TCE (1)	100%	290 - 9,500	100%	130
TCE (2)	100%	250 - 8,100	100%	130
TCE (3)	100%	53 - 11,000	82%	130
TCE (4)	100%	92 - 8,500	91%	130

*Screening level provided is the draft project-specific RIASL₁₂.

Table 304-2 summarizes the indoor air results relative to the sub-slab soil gas exceedances, since VI only potentially occurs if the analyte is present in both sub-slab soil gas and indoor air. Therefore, the table below provides the analyte detected above applicable screening levels in sub-slab soil gas as well as the corresponding indoor air sample result. The outdoor air sample result is also provided to determine if the analytes were present in indoor air due to migration from outdoor air.

Table 304-2. Vapor Intrusion Evaluation for Building 304

Analyte (Sampling Event)	Indoor Air Detection Frequency	Indoor Air Measured Range ($\mu\text{g}/\text{m}^3$)	Indoor Air Screening Level* ($\mu\text{g}/\text{m}^3$)	Outdoor Air Result ($\mu\text{g}/\text{m}^3$)
1,1,2-Trichloroethane (1)	0%	ND	0.62	ND
1,1,2-Trichloroethane (2)	0%	ND	0.62	ND
1,1,2-Trichloroethane (3)	0%	ND	0.62	ND
1,1,2-Trichloroethane (4)	0%	ND	0.62	ND
1,2-Dichloroethane (1)	0%	ND	4.6	ND
1,2-Dichloroethane (2)	45%	0.16 - 0.24	4.6	ND
1,2-Dichloroethane (3)	55%	0.13 - 0.20	4.6	ND
1,2-Dichloroethane (4)	45%	0.14 - 0.20	4.6	ND
1,2-Dichloropropane (1)	0%	ND	12.2	ND
1,2-Dichloropropane (2)	0%	ND	12.2	ND
1,2-Dichloropropane (3)	0%	ND	12.2	ND
1,2-Dichloropropane (4)	0%	ND	12.2	ND
Carbon Tetrachloride (1)	100%	0.37 - 0.42	22	0.38
Carbon Tetrachloride (2)	100%	0.6 - 0.89	22	0.51
Carbon Tetrachloride (3)	100%	0.54 - 0.76	22	0.54
Carbon Tetrachloride (4)	100%	0.40 - 0.53	22	0.54
Chloroform (1)	0%	ND	5.2	ND
Chloroform (2)	73%	0.18 - 0.50	5.2	ND
Chloroform (3)	100%	0.43 - 1.2	5.2	0.37
Chloroform (4)	45%	0.16 - 0.29	5.2	ND
cis-1,2-Dichloroethene (1)	9%	1.6	24	ND
cis-1,2-Dichloroethene (2)	45%	0.14 - 0.30	24	ND
cis-1,2-Dichloroethene (3)	18%	0.16 - 0.82	24	ND
cis-1,2-Dichloroethene (4)	9%	0.25	24	ND
Dibromochloromethane (1)	0%	ND	5	ND
Dibromochloromethane (2)	0%	ND	5	ND
Dibromochloromethane (3)	0%	ND	5	ND
Dibromochloromethane (4)	0%	ND	5	ND
Ethylbenzene (1)	18%	0.34 - 0.42	48	ND
Ethylbenzene (2)	100%	0.33 - 1.6	48	ND
Ethylbenzene (3)	100%	0.16 - 0.82	48	0.18
Ethylbenzene (4)	36%	0.20 - 0.36	48	ND
Tetrachloroethene (1)	100%	0.26 - 2.8	82	ND
Tetrachloroethene (2)	100%	3.3 - 12	82	ND
Tetrachloroethene (3)	100%	0.66 - 4.4	82	0.59
Tetrachloroethene (4)	100%	0.31 - 6.2	82	ND
TCE (1)	9%	9	4	ND
TCE (2)	100%	0.31 - 0.92	4	ND
TCE (3)	73%	0.19 - 1.8	4	ND
TCE (4)	64%	0.18 - 0.31	4	ND

*Screening level provided is the draft project-specific RIASL₁₂.

All indoor air results for Building 304, with the exception of a single result for TCE during E1, are below screening levels. Based on the results from E1, further investigation activities were conducted for Building 304 and documented in the Summary of Investigative Findings (October 2019). The goal for the building-specific investigation for Building 304 was to gain an understanding of potential sources and distribution of TCE concentrations. Throughout the seasonal confirmation sampling events, there was only one RIASL₁₂ exceedance that occurred in the kitchen area (304-IA-02) during the initial sampling event, which occurred during the Fall 2017 sampling season. Appendix C presents the October 2019 Summary of Further Investigation Findings report.

Baseline samples were collected at locations focused in and around the kitchen area where the only TCE indoor air exceedance had occurred (304-xx-02), as well as at additional sample locations within the

process area. All baseline samples collected had TCE concentrations less than 0.09 ppbv ($0.50 \mu\text{g}/\text{m}^3$). The kitchen area sample had a TCE concentration of 0.04 ppbv ($0.22 \mu\text{g}/\text{m}^3$), while the highest TCE concentrations were discovered at the additional sample locations 304-W4 and 304-W5 in the drum conveying area, just west and north of the control room. The PID meter consistently read zero ppbv throughout the office, lab, and kitchen areas, and only up to 20 ppbv in the drum conveying area.

Due to very low levels of TCE detected in the baseline event (all less than screening levels) and only a single exceedance of $9 \mu\text{g}/\text{m}^3$ detected throughout four prior seasonal confirmation sampling events, it was determined that no significant VI is currently occurring in Building 304 and the findings indicate that the TCE concentrations detected in indoor air in Building 304 are due to active workplace chemical use.

VAPOR INTRUSION CONCEPTUAL SITE MODEL

VI is an exposure pathway that results from the migration of volatilized chemicals from the subsurface to indoor air in overlying occupied buildings. A source, migration route and a human receptor must be present for the VI pathway to be complete. The focus of this building specific investigation is to evaluate the potential VI exposure pathway for employees and contractors at Building 304. The CSM is illustrated in Figure 5.4.2-3.

Building 304 is located in the southwestern quadrant of the Midland facility and is known as the Dow Automotive and Brake Fluids Building. Per aerial photography, the western two thirds of the structure were constructed before 1938 and the eastern third was constructed in the 1950s. The 26,465 ft² building consists of office space, a control room, locker rooms, a kitchen, lab space, warehouse space, shop/storage space, a small mixing/blending process area for brake fluid, and a packaging area. The building is roughly two stories tall. The building is a slab-on-grade construction with no basement or elevators; however, the ground surface was built up to accommodate truck bays on the south side of the building. The ground surface around the building is concrete and asphalt on the southern and eastern sides, gravel and grassy medians/beds on the western side, and gravel and railroad tracks on the northern side.

Approximately 10-15 occupants work an 8-hour day shift during the week and very rarely work weekend hours. The occupants use a contracted laundry service to clean uniforms and work clothes; however, there are some washer/dryers located in the second floor locker room on the south side of the building. The occupants do use gas-powered equipment on occasion in the warehouse portion of the building and the gasoline/fuels are rarely stored in the building. The typical parameters for non-residential exposures are assumed to apply to the various personnel stationed during work shifts at this building (i.e., 40 hours/week, 50 weeks/year exposure).

The building is heated via hot air circulation in the office areas, but steam heaters are used in the warehouse and shop area. The office areas and lab area are cooled via three central AC units. Two intakes are located on the south side of the building. Mechanical fans are also used in the vicinity of the truck bays. Four exhaust fans are located on the north side of the warehouse, and one exhaust fan is located on the east side of the shop area. The lab does contain a lab hood on its western wall. The eight bay doors, which are mainly on the south side of the building in the warehouse area, are predominantly open all the time during the summer, but are shut as much as possible during the colder, winter months.

A building survey completed before the initial sampling event. Drains and other openings were screened with a PID and no soil gas entry points were identified. A chemical inventory was completed during the building survey that identified cleaners, motor oil, acetone, methanol, and spray paint.

EVALUATION OF SEASONAL CONFIRMATION SAMPLING EVENTS

Four seasonal sampling events have been completed at Building 304. The sampling events encompass more than one year of time and include sampling during each season of the year. The results from the

four seasonal confirmation sampling events were evaluated with respect to spatial variability, temporal variability, and seasonal trend analysis.

Building specific attenuation factors (α) were calculated and compared between events to evaluate temporal variability and determine the best estimate of a building-specific attenuation factor. This evaluation serves to confirm that the existing study design is appropriate, and also provides insight for the determination of the path forward for this building.

This evaluation focused on any analytes detected in the sub-slab soil gas samples that met the criterion for inclusion in one or more of the following categories:

- a) Analytes detected in sub-slab soil-gas at concentrations that exceeded draft project-specific screening levels;
- b) Analytes detected in sub-slab soil-gas at concentrations of 1,000 $\mu\text{g}/\text{m}^3$ or greater in one or more samples. Data for analytes detected above 1,000 $\mu\text{g}/\text{m}^3$ should provide the clearest signal and be the simplest to interpret when assessing data trends. The same data trends observed for these analytes are expected to apply to other similar analytes present at lower concentrations; and
- c) PCE and TCE. These two analytes are of particular interest for many VI evaluations at industrial sites.

For this building, the analytes detected in the sub-slab soil gas at concentrations above the draft project-specific screening levels were 1,1,2-TCA, EDC, 1,2-DCP, carbon tetrachloride, chloroform, cis-1,2-DCE, dibromochloromethane, ethylbenzene, PCE, and TCE. Six additional analytes had a detected concentration $\geq 1,000 \mu\text{g}/\text{m}^3$: 1,1,1-TCA, 1,1-dichloroethane, acetone, ethanol, toluene, and total xylenes. Due to low detection frequency or intermittent detections, five of those analytes are not included for further evaluation (1,1-dichloroethane, acetone, ethanol, toluene, and total xylenes). 1,1,1-TCA was included for evaluation. Sample results for these analytes are provided in the following data tables below:

Summary of Results for 1,1,2-Trichloroethane (1,1,2-TCA)

Sample Type	Sample ID	Measured Concentration ($\mu\text{g}/\text{m}^3$)			
		Nov. 2017	Mar. 2018	Aug. 2018	Feb. 2019
		E1	E2	E3	E4
Outdoor Air	304-OA-01	<0.18	<0.18	<0.19	<0.18
Indoor Air	304-IA-01	<0.19	<0.20	<0.17	<0.18
	304-IA-02	<0.19	<0.20	<0.17	<0.18
	304-IA-03	<0.18	<0.19	<0.19	<0.18
	304-IA-04	<0.19	<0.18	<0.18	<0.18
	304-IA-05	<0.19	<0.17	<0.17	<0.18
	304-IA-06	<0.19	<0.18	<0.17	<0.18
	304-IA-07	<0.20	<0.19	<0.17	<0.19
	304-IA-08	<0.18	<0.19	<0.17	<0.18
	304-IA-09	<0.20	<0.19	<0.18	<0.20
	304-IA-10	<0.18	<0.18	<0.19	<0.18
	304-IA-11	<0.18	<0.20	<0.17	<0.20
Sub-Slab Soil Gas	304-SS-01	<84	<46	<83	<76
	304-SS-02	<84	<72	<100	<80
	304-SS-03	<80	<71	<88	<41
	304-SS-04	<41	<41	<43	<81
	304-SS-05	<43	42	<88	<53
	304-SS-06	<41	<45	<52	<52
	304-SS-07	<12	<18	<13	<21
	304-SS-08	<9.1	<8.6	<4.1	<6.2
	304-SS-09	<14	<15	<22	<12
	304-SS-10	<7.2	<4	<13	<4.1
	304-SS-11	<40	<40	<4.4	<89

Screening levels for indoor air are $0.62 \mu\text{g}/\text{m}^3$ (RIASL₁₂/TSRIASL₁₂)
Screening levels for soil-gas are $20 \mu\text{g}/\text{m}^3$ (RIASL₁₂/TSRIASL₁₂)

	RIASL12 Exceedance
	TSRIASL12 Exceedance

Summary of Results for 1,2-Dichloroethane (EDC)

Sample Type	Sample ID	Measured Concentration ($\mu\text{g}/\text{m}^3$)			
		Nov. 2017	Mar. 2018	Aug. 2018	Feb. 2019
		E1	E2	E3	E4
Outdoor Air	304-OA-01	<0.14	<0.13	<0.14	<0.13
Indoor Air	304-IA-01	<0.14	0.20	0.17	0.20
	304-IA-02	<0.14	0.18	0.18	0.19
	304-IA-03	<0.14	0.16	0.20	0.15
	304-IA-04	<0.14	0.16	0.14	0.14
	304-IA-05	<0.14	0.24	<0.13	0.14
	304-IA-06	<0.14	<0.14	0.13	<0.14
	304-IA-07	<0.15	<0.14	<0.13	<0.14
	304-IA-08	<0.14	<0.14	0.14	<0.13
	304-IA-09	<0.15	<0.14	<0.13	<0.14
	304-IA-10	<0.14	<0.14	<0.14	<0.14
	304-IA-11	<0.13	0.15	<0.13	<0.14
Sub-Slab Soil Gas	304-SS-01	4,800	3,600	4,300	3,500
	304-SS-02	3,600	3,800	5,000	3,000
	304-SS-03	1,900	1,800	2,000	780
	304-SS-04	410	300	390	160
	304-SS-05	410	430	480	350
	304-SS-06	<30	<33	64	<39
	304-SS-07	12	<13	<9.7	<16
	304-SS-08	<6.8	<6.4	<3	<4.6
	304-SS-09	<11	<11	<16	<9
	304-SS-10	12	<3	<9.9	<3
	304-SS-11	120	30	<3.3	<66

Screening levels for indoor air are $4.6 \mu\text{g}/\text{m}^3$ (RIASL₁₂/TSRIASL₁₂)
Screening levels for soil-gas are $150 \mu\text{g}/\text{m}^3$ (RIASL₁₂/TSRIASL₁₂)

	RIASL12 Exceedance
	TSRIASL12 Exceedance

Summary of Results for 1,2-Dichloropropane (1,2-DCP)

Sample Type	Sample ID	Measured Concentration (µg/m ³)			
		Nov. 2017	Mar. 2018	Aug. 2018	Feb. 2019
		E1	E2	E3	E4
Outdoor Air	304-OA-01	<0.78	<0.75	<0.79	<0.74
Indoor Air	304-IA-01	<0.79	<0.87	<0.73	<0.75
	304-IA-02	<0.79	<0.83	<0.74	<0.75
	304-IA-03	<0.78	<0.8	<0.79	<0.74
	304-IA-04	<0.79	<0.78	<0.76	<0.75
	304-IA-05	<0.79	<0.72	<0.74	<0.75
	304-IA-06	<0.82	<0.78	<0.72	<0.78
	304-IA-07	<0.84	<0.79	<0.74	<0.79
	304-IA-08	<0.78	<0.8	<0.73	<0.74
	304-IA-09	<0.87	<0.79	<0.76	<0.83
	304-IA-10	<0.78	<0.78	<0.79	<0.78
	304-IA-11	<0.74	<0.84	<0.74	<0.83
Sub-Slab Soil Gas	304-SS-01	5,800	4,000	4,600	4,400
	304-SS-02	5,800	6,100	7,400	4,800
	304-SS-03	6,300	5,700	5,900	2,200
	304-SS-04	1,900	1,000	1,900	580
	304-SS-05	1,200	1,400	1,700	1,000
	304-SS-06	510	650	1,200	610
	304-SS-07	13	<15	<11	<18
	304-SS-08	<7.7	7.7	<3.5	<5.2
	304-SS-09	16	14	<18	<10
	304-SS-10	<6.1	<3.4	<11	<3.4
	304-SS-11	57	43	<3.8	<76

Screening levels for indoor air are 12.2 µg/m³ (RIASL₁₂/TSRIASL₁₂)
Screening levels for soil-gas are 410 µg/m³ (RIASL₁₂/TSRIASL₁₂)

	RIASL12 Exceedance
	TSRIASL12 Exceedance

Summary of Results for Carbon Tetrachloride

Sample Type	Sample ID	Measured Concentration (µg/m ³)			
		Nov. 2017	Mar. 2018	Aug. 2018	Feb. 2019
		E1	E2	E3	E4
Outdoor Air	304-OA-01	0.38	0.51	0.54	0.47
Indoor Air	304-IA-01	0.41	0.60	0.57	0.48
	304-IA-02	0.42	0.64	0.56	0.53
	304-IA-03	0.40	0.64	0.76	0.52
	304-IA-04	0.41	0.65	0.58	0.46
	304-IA-05	0.42	0.62	0.60	0.52
	304-IA-06	0.41	0.67	0.60	0.49
	304-IA-07	0.38	0.86	0.60	0.40
	304-IA-08	0.37	0.89	0.57	0.40
	304-IA-09	0.39	0.82	0.54	0.48
	304-IA-10	0.39	0.62	0.60	0.49
	304-IA-11	0.37	0.65	0.60	0.40
Sub-Slab Soil Gas	304-SS-01	2,300	1,500	2,200	1,800
	304-SS-02	1,800	2,100	2,900	1,700
	304-SS-03	2,200	2,100	2,600	820
	304-SS-04	1,000	520	1,500	330
	304-SS-05	790	590	930	600
	304-SS-06	620	500	1,500	490
	304-SS-07	150	230	100	120
	304-SS-08	130	72	44	28
	304-SS-09	140	140	180	62
	304-SS-10	54	21	80	14
	304-SS-11	1,000	890	22	440

Screening levels for indoor air are 22 µg/m³ (RIASL₁₂/TSRIASL₁₂)
Screening levels for soil-gas are 710 µg/m³ (RIASL₁₂/TSRIASL₁₂)

	RIASL12 Exceedance
	TSRIASL12 Exceedance

Summary of Results for Chloroform

Sample Type	Sample ID	Measured Concentration (µg/m ³)			
		Nov. 2017	Mar. 2018	Aug. 2018	Feb. 2019
		E1	E2	E3	E4
Outdoor Air	304-OA-01	<0.17	<0.16	0.37	<0.16
Indoor Air	304-IA-01	<0.17	<0.18	0.69	0.17
	304-IA-02	<0.17	0.18	0.72	0.22
	304-IA-03	<0.17	<0.17	0.61	0.16
	304-IA-04	<0.17	<0.16	0.64	<0.16
	304-IA-05	<0.17	0.23	0.53	0.29
	304-IA-06	<0.18	0.20	0.57	<0.16
	304-IA-07	<0.16	0.44	0.48	<0.17
	304-IA-08	<0.18	0.50	0.47	0.16
	304-IA-09	<0.17	0.38	0.43	<0.17
	304-IA-10	<0.16	0.20	1.2	<0.16
	304-IA-11	<0.16	0.19	0.46	<0.17
Sub-Slab Soil Gas	304-SS-01	1,400	1,100	1,400	1,300
	304-SS-02	1,400	1,700	2,200	1,400
	304-SS-03	1,400	1,600	1,800	620
	304-SS-04	580	360	820	190
	304-SS-05	510	510	640	450
	304-SS-06	150	180	510	180
	304-SS-07	18	25	2	<19
	304-SS-08	12	12	5.7	<5.5
	304-SS-09	16	27	21	14
	304-SS-10	24	16	42	7.1
	304-SS-11	180	180	5.2	87

Screening levels for indoor air are 5.2 µg/m³ (RIASL₁₂) and 52 µg/m³ (TSRIASL₁₂)
Screening levels for soil-gas are 170 µg/m³ (RIASL₁₂) and 1,700 µg/m³ (TSRIASL₁₂)

	RIASL12 Exceedance
	TSRIASL12 Exceedance

Summary of Results for cis-1,2-Dichloroethene (cis-1,2-DCE)

Sample Type	Sample ID	Measured Concentration (µg/m ³)			
		Nov. 2017	Mar. 2018	Aug. 2018	Feb. 2019
		E1	E2	E3	E4
Outdoor Air	304-OA-01	<0.13	<0.13	<0.14	<0.13
Indoor Air	304-IA-01	<0.14	<0.15	<0.13	<0.13
	304-IA-02	1.6	<0.14	<0.13	<0.13
	304-IA-03	<0.13	<0.14	<0.14	<0.13
	304-IA-04	<0.14	<0.13	0.16	<0.13
	304-IA-05	<0.14	<0.12	<0.13	<0.13
	304-IA-06	<0.14	<0.13	<0.12	<0.13
	304-IA-07	<0.14	0.19	<0.13	<0.14
	304-IA-08	<0.13	0.21	0.82	<0.13
	304-IA-09	<0.15	0.21	<0.13	<0.14
	304-IA-10	<0.13	0.30	<0.14	0.25
	304-IA-11	<0.13	0.14	<0.13	<0.14
Sub-Slab Soil Gas	304-SS-01	200	190	210	220
	304-SS-02	220	350	420	310
	304-SS-03	63	100	86	57
	304-SS-04	<30	<30	<32	<59
	304-SS-05	39	52	<64	<38
	304-SS-06	<30	<33	<37	<38
	304-SS-07	9.6	<13	<9.5	<16
	304-SS-08	<6.6	<6.2	<3	<4.5
	304-SS-09	<10	<11	<16	<8.9
	304-SS-10	<5.3	13	<9.7	<3
	304-SS-11	1,200	660	4.7	200

Screening levels for indoor air are 24 µg/m³ (RIASL₁₂) and 72 µg/m³ (TSRIASL₁₂)
Screening levels for soil-gas are 820 µg/m³ (RIASL₁₂) and 2,500 µg/m³ (TSRIASL₁₂)

	RIASL12 Exceedance
	TSRIASL12 Exceedance

Summary of Results for Dibromochloromethane

Sample Type	Sample ID	Measured Concentration ($\mu\text{g}/\text{m}^3$)			
		Nov. 2017	Mar. 2018	Aug. 2018	Feb. 2019
		E1	E2	E3	E4
Outdoor Air	304-OA-01	<1.4	<1.4	<1.4	<1.4
Indoor Air	304-IA-01	<1.5	<1.6	<1.4	<1.4
	304-IA-02	<1.4	<1.5	<1.4	<1.4
	304-IA-03	<1.4	<1.5	<1.4	<1.4
	304-IA-04	<1.5	<1.4	<1.4	<1.4
	304-IA-05	<1.5	<1.3	<1.4	<1.4
	304-IA-06	<1.5	<1.4	<1.3	<1.4
	304-IA-07	<1.6	<1.5	<1.4	<1.4
	304-IA-08	<1.4	<1.5	<1.4	<1.4
	304-IA-09	<1.6	<1.5	<1.4	<1.5
	304-IA-10	<1.4	<1.4	<1.4	<1.4
	304-IA-11	<1.4	<1.5	<1.4	<1.5
Sub-Slab Soil Gas	304-SS-01	<130	<71	<130	<120
	304-SS-02	<130	<110	<160	<120
	304-SS-03	<120	<110	190	<65
	304-SS-04	<65	<65	<68	<130
	304-SS-05	<68	<64	<140	<82
	304-SS-06	<63	<70	<80	<81
	304-SS-07	<19	<28	<20	<34
	304-SS-08	<14	<13	<6.4	<9.6
	304-SS-09	<23	<23	<34	<19
	304-SS-10	<11	<6.3	<21	<6.3
	304-SS-11	<62	<62	<6.9	<140

Screening levels for indoor air are $5 \mu\text{g}/\text{m}^3$ (RIASL₁₂/TSRIASL₁₂)
Screening levels for soil-gas are $170 \mu\text{g}/\text{m}^3$ (RIASL₁₂/TSRIASL₁₂)

	RIASL12 Exceedance
	TSRIASL12 Exceedance

Summary of Results for Ethylbenzene

Sample Type	Sample ID	Measured Concentration (µg/m ³)			
		Nov. 2017	Mar. 2018	Aug. 2018	Feb. 2019
		E1	E2	E3	E4
Outdoor Air	304-OA-01	<0.15	<0.14	0.18	<0.14
Indoor Air	304-IA-01	<0.15	0.39	0.27	<0.14
	304-IA-02	<0.15	0.42	0.33	<0.14
	304-IA-03	34	0.61	0.78	0.36
	304-IA-04	42	0.64	0.82	0.32
	304-IA-05	<0.15	1.6	0.30	<.14
	304-IA-06	<0.15	0.33	0.31	0.20
	304-IA-07	<0.16	0.81	0.18	<0.15
	304-IA-08	<0.15	0.62	0.17	<0.14
	304-IA-09	<0.16	0.76	0.16	0.23
	304-IA-10	<0.14	0.96	0.18	<0.14
	304-IA-11	<0.14	0.54	0.20	<0.16
Sub-Slab Soil Gas	304-SS-01	<67	<36	<66	<61
	304-SS-02	<67	<58	<83	<63
	304-SS-03	<64	<57	<70	<33
	304-SS-04	2,000	<33	3,400	110
	304-SS-05	<34	<33	<70	<42
	304-SS-06	<32	<36	<41	<41
	304-SS-07	12	<14	<10	<17
	304-SS-08	18	<6.8	4.4	<4.9
	304-SS-09	<12	<12	<17	<9.7
	304-SS-10	6	<3.2	<11	<3.2
	304-SS-11	<32	<32	<3.5	<71

Screening levels for indoor air are 48 µg/m³ (RIASL₁₂) and 480 µg/m³ (TSRIASL₁₂)
Screening levels for soil-gas are 170 µg/m³ (RIASL₁₂) and 1,700 µg/m³ (TSRIASL₁₂)

	RIASL12 Exceedance
	TSRIASL12 Exceedance

Summary of Results for Tetrachloroethene (PCE)

Sample Type	Sample ID	Measured Concentration (µg/m ³)			
		Nov. 2017	Mar. 2018	Aug. 2018	Feb. 2019
		E1	E2	E3	E4
Outdoor Air	304-OA-01	<0.23	<0.22	<0.59	<0.22
Indoor Air	304-IA-01	2.5	5.4	4.4	5
	304-IA-02	2.8	6.8	4.2	5.5
	304-IA-03	2.2	10	4.2	6.2
	304-IA-04	2	9.9	4.3	5.8
	304-IA-05	2.1	9	3.3	3.6
	304-IA-06	2.2	12	3.3	4.6
	304-IA-07	0.32	6.7	0.78	0.42
	304-IA-08	0.26	6.7	3.3	0.31
	304-IA-09	0.3	7.5	0.66	0.75
	304-IA-10	1.5	3.3	0.97	1
	304-IA-11	0.56	3.9	0.71	0.34
Sub-Slab Soil Gas	304-SS-01	140,000	90,000	120,000	120,000
	304-SS-02	120,000	120,000	160,000	110,000
	304-SS-03	120,000	110,000	130,000	60,000
	304-SS-04	54,000	28,000	60,000	25,000
	304-SS-05	11,000	16,000	18,000	12,000
	304-SS-06	12,000	16,000	33,000	17,000
	304-SS-07	4,700	6,100	3,200	5,100
	304-SS-08	3,200	3,300	1,300	1,400
	304-SS-09	5,500	5,900	5,700	3,200
	304-SS-10	2,600	1,400	3,700	1,100
	304-SS-11	53,000	59,000	960	22,000

Screening levels for indoor air are 82 µg/m³ (RIASL₁₂/TSRIASL₁₂)
Screening levels for soil-gas are 2,700 µg/m³ (RIASL₁₂/TSRIASL₁₂)

	RIASL12 Exceedance
	TSRIASL12 Exceedance

Summary of Results for Trichloroethene (TCE)

Sample Type	Sample ID	Measured Concentration ($\mu\text{g}/\text{m}^3$)			
		Nov. 2017	Mar. 2018	Aug. 2018	Feb. 2019
		E1	E2	E3	E4
Outdoor Air	304-OA-01	<0.18	<0.18	<0.18	<0.17
Indoor Air	304-IA-01	<0.18	0.42	0.28	<0.17
	304-IA-02	9	0.37	0.29	0.24
	304-IA-03	<0.18	0.48	0.27	0.31
	304-IA-04	<0.18	0.48	0.27	0.28
	304-IA-05	<0.18	0.42	0.28	0.25
	304-IA-06	<0.19	0.46	0.23	0.18
	304-IA-07	<0.2	0.87	<0.17	<0.18
	304-IA-08	<0.18	0.92	1.8	0.23
	304-IA-09	<0.20	0.76	<0.18	<0.19
	304-IA-10	<0.18	0.31	0.19	<0.18
	304-IA-11	<0.17	0.31	<0.17	0.21
Sub-Slab Soil Gas	304-SS-01	9,500	6,900	8,200	8,500
	304-SS-02	7,700	8,100	11,000	7,700
	304-SS-03	6,000	5,700	6,500	2,700
	304-SS-04	2,700	1,800	3,200	850
	304-SS-05	1,300	1,600	1,800	1,300
	304-SS-06	560	590	1,500	680
	304-SS-07	350	380	200	230
	304-SS-08	300	320	130	92
	304-SS-09	290	400	350	210
	304-SS-10	470	250	720	180
	304-SS-11	2,900	2,500	53	1,100

Screening levels for indoor air are $4 \mu\text{g}/\text{m}^3$ (RIASL₁₂) and $12 \mu\text{g}/\text{m}^3$ (TSRIASL₁₂)
 Screening levels for soil-gas are $130 \mu\text{g}/\text{m}^3$ (RIASL₁₂) and $400 \mu\text{g}/\text{m}^3$ (TSRIASL₁₂)

	RIASL12 Exceedance
	TSRIASL12 Exceedance

Summary of Results for 1,1,1-Trichloroethane (1,1,1-TCA)

Sample Type	Sample ID	Measured Concentration ($\mu\text{g}/\text{m}^3$)			
		Nov. 2017	Mar. 2018	Aug. 2018	Feb. 2019
		E1	E2	E3	E4
Outdoor Air	304-OA-01	<0.18	<0.18	<0.19	<0.18
Indoor Air	304-IA-01	<0.19	<0.2	<0.17	<0.18
	304-IA-02	<0.19	<0.2	<0.17	<0.18
	304-IA-03	<0.18	<0.19	<0.19	<0.18
	304-IA-04	<0.19	<0.18	<0.18	<0.18
	304-IA-05	<0.19	<0.17	<0.17	<0.18
	304-IA-06	<0.19	<0.18	<0.17	<0.18
	304-IA-07	<0.2	0.33	<0.17	<0.19
	304-IA-08	<0.18	0.3	<0.17	<0.18
	304-IA-09	<0.2	0.32	<0.18	<0.2
	304-IA-10	<0.18	0.31	<0.19	<0.18
	304-IA-11	<0.18	0.27	<0.17	<0.2
Sub-Slab Soil Gas	304-SS-01	2,600	1,800	2,600	2,000
	304-SS-02	2,100	2,300	3,100	1,900
	304-SS-03	2,100	2,000	2,400	820
	304-SS-04	1,100	520	1,400	320
	304-SS-05	180	140	210	140
	304-SS-06	150	140	430	160
	304-SS-07	220	480	200	220
	304-SS-08	33	42	34	16
	304-SS-09	94	98	190	47
	304-SS-10	60	41	200	24
	304-SS-11	5,100	4,900	91	3,200

Screening levels for indoor air are $7,000 \mu\text{g}/\text{m}^3$ (RIASL₁₂/TSRIASL₁₂)

Screening levels for soil-gas are $230,000 \mu\text{g}/\text{m}^3$ (RIASL₁₂/TSRIASL₁₂)

	RIASL12 Exceedance
	TSRIASL12 Exceedance

EVALUATION OF VI DATA TRENDS

Data trends for Building 304 are discussed below for both sub-slab soil gas and indoor air. When data exhibit a narrow range of variability, it is typical practice to express the range as a percentage (e.g., relative percent difference [RPD]). When data exhibit a large range of variability, however, it is more useful to express the range in orders of magnitude (i.e., factors of 10). This can be expressed mathematically as the log of the ratio of maximum/minimum values. If the values differ by a factor of 10, the log of the ratio is 1, if the values differ by a factor of 100, the log of the ratio is 2, and so on.

The variability across all locations over all sampling events is the total variability. This encompasses different types of variability, including spatial variability (i.e., how do the results vary from location to location), temporal variability (i.e., how do the results at a given location vary over time), and measurement variability. Measurement variability can be determined by evaluating results of duplicate or collocated samples and includes both sampling variability and analytical variability.

Sub-Slab Soil Gas Data Trends

Spatial Variability of Sub-Slab Soil Gas – The soil gas exhibit up to three orders of magnitude of spatial variability. For example, sub-slab soil gas detections of PCE vary from 960 to 160,000 $\mu\text{g}/\text{m}^3$ (log of max./min. = 2.2) across all 11 locations for E3. Sub-slab soil gas detections of TCE range from 53 to 11,000 $\mu\text{g}/\text{m}^3$ (log of max./min. = 2.3), across all 11 locations for E3. Detected concentrations of cis-1,2-dichloroethene in sub-slab soil gas vary from 10 to 1,200 $\mu\text{g}/\text{m}^3$ (log max./min. = 2.1) for E1.

Temporal Variability of Soil Gas – The soil gas concentrations exhibit up to two orders of magnitude of temporal variability. For PCE, sub-slab soil gas concentrations vary from 960 to 59,000 $\mu\text{g}/\text{m}^3$ at location 304-SS-11 (log max/min = 1.8). The results for other sample locations are lower for PCE. For TCE, sub-slab soil gas concentrations of vary from 53 to 2,900 $\mu\text{g}/\text{m}^3$ at location 304-SS-11 (log max/min = 1.7). TCE results for the remaining sample locations are lower. Sub-slab soil gas concentrations of ethylbenzene vary from 0.32 to 42 $\mu\text{g}/\text{m}^3$ at location 304-SS-04 (log max/min = 2.1) with less variation at the remaining sample locations. Overall, as expected, the amount of temporal variability is less than the amount of spatial variability.

Seasonal Confirmation Sampling Trend Analysis – No formal statistical tests were performed, but the data exhibits consistent results between the seasons. This is demonstrated by the graph below, which shows analytes selected above at locations where they were detected at relatively high concentrations. Note that the y-axis is a log scale.

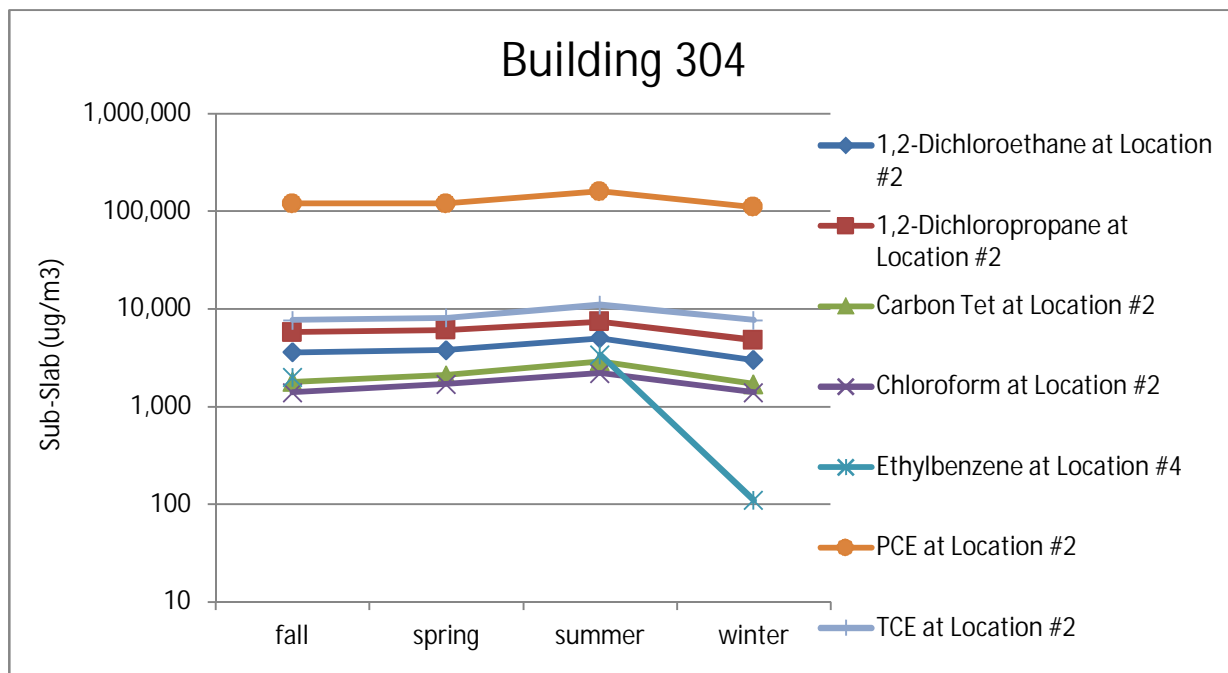

The data set was examined to see what the potential consequences would have been had only a single sampling event been performed. For the analytes above, including PCE and TCE, the highest sub-slab soil gas concentrations were collected during the summer (E3) and the lowest concentrations occurred during the winter (E4). Overall, the minimum and maximum values appear to be consistent between sampling events. Therefore, implementing four seasonal confirmation sampling events provided only limited insight regarding maximum concentration levels, but the larger data set served to increase the confidence in the findings including demonstrating the consistency of the maximum reported results.

For PCE, a concentration of 120,000 $\mu\text{g}/\text{m}^3$ was measured during E1 and the highest concentration (160,000 $\mu\text{g}/\text{m}^3$) was measured during E3. If only E1 had been performed, a negative bias of 33% would have been introduced (i.e., the E3 result was 33% higher than the E1 result). For TCE, the detected concentration in E1 was 7,700 $\mu\text{g}/\text{m}^3$ and the highest concentration overall (11,000 $\mu\text{g}/\text{m}^3$) was measured during E3. If only E1 had been performed, a negative bias of 43% would have been introduced. Therefore, implementing four seasonal confirmation sampling events provided some insight regarding maximum concentration levels and the larger data set served to increase the confidence in the findings.

Indoor Air Data Trends

Spatial Variability of Indoor Air – The indoor air exhibits up to one order of magnitude of spatial variability. For PCE in E4, indoor air concentrations vary from 0.3 to 6.2 $\mu\text{g}/\text{m}^3$ (log max./min. = 1.3). The other events saw less variability. For TCE, the highest spatial variability occurred during E3 where indoor air concentrations vary from 0.19 to 1.8 $\mu\text{g}/\text{m}^3$ (log max./min. = 0.98).

Temporal Variability of Indoor Air – The indoor air has one order of magnitude of temporal variability. For example, indoor air concentrations of PCE at location 304-IA-04 varied from 0.32 to 6.7 $\mu\text{g}/\text{m}^3$ (log of max./min. = 1.3). For TCE at location 304-IA-02, concentrations varied from 0.24 to 9 $\mu\text{g}/\text{m}^3$ (log max./min. = 1.6). Overall, temporal variability across the four seasons sampled is relatively small.

Additional Analyses

Comparison of Sub-Slab Soil Gas and Indoor Air Data Sets – The sub-slab soil gas data exhibit a higher level of spatial variability when compared to the indoor air data set. This suggests that there are no significant indoor sources of the AOs or that emissions from any indoor air sources tend to be well distributed in this building.

Seasonal Effects – The sub-slab soil gas data exhibit relatively little variability from event to event. Maximum sub-slab soil gas values for PCE and TCE occurred in E3 (summer). Maximum indoor air values for PCE and TCE occurred in E3 and E2 (summer and spring, respectively). The data vary but do not support the hypothesis that wintertime should have the highest indoor air impacts.

Comparison of Attenuation Factors by Event – Attenuation factors were calculated for PCE based on maximum values. Detections in outdoor air were insignificant to detected indoor air concentrations. Therefore, the indoor air maximum concentration was not corrected for contribution of outdoor air to indoor air. The calculated event-specific attenuation factors are shown in Table 304-3.

Table 304-3. Comparison of Building-Specific Attenuation Factors for PCE by Event

	E1 (Fall)	E2 (Spring)	E3 (Summer)	E4 (Winter)
Maximum Values				
PCE in Sub-Slab Soil Gas ($\mu\text{g}/\text{m}^3$)	140,000	120,000	160,000	120,000
PCE in Indoor Air ($\mu\text{g}/\text{m}^3$)	2.8	12	4.4	6.2
Attenuation Factor	2.0E-05	1.0E-04	2.8E-05	5.2E-05

These serve as the best estimates of attenuation at this building. The results can vary from day to day due to differences in rates of vapor intrusion and rates of building ventilation. Overall, the most conservative estimate of a building-specific attenuation factor for Building 304 is 1E-04 based on PCE during E2.

Temporal Variability in Attenuation Factor – As shown in Table 304-3, there was about one order of magnitude of temporal variability in the calculated attenuation factors observed for PCE.

To be as conservative as possible, the maximum values were used in calculating the attenuation factor for each event. The sampling location with the maximum value per event varied. Generally, the maximum indoor air values were similar across events. In general, the low spatial variability in indoor air results means that roughly comparable attenuation factors would be obtained whichever indoor air value was used in the calculations.

NON-DETECT EVALUATION

Table 304-3 below lists the analytes in sub-slab soil gas that have ND RLs greater than the screening levels. The table also includes the indoor air results for each of the analytes. If a sub-slab soil gas analyte has ND RL exceedances, but all results and ND RLs in indoor air are below the screening levels,

no further evaluation is warranted. If an analyte was identified as an AOI in sub-slab soil gas (detected results > screening level), it is excluded from the ND evaluation. Also, if an ND analyte has an 0% detection frequency for all sampling events and all ND RLs met the screening level during at least one event, no further ND evaluation is warranted.

Table 304-3. Non Detect Evaluation for Building 304

Soil Gas Analytes with ND RL > SL	Indoor Air Result Summary
1,1,2,2-Tetrachloroethane	0% Detection Frequency, All ND RLs < RIASL ₁₂
1,1,2-Trichloroethane	0% Detection Frequency, All ND RLs < RIASL ₁₂
1,2,4-Trichlorobenzene	0% Detection Frequency, All ND RLs < TSRIASL ₁₂
1,2-Dibromoethane (EDB)	0% Detection Frequency, All ND RLs > RIASL ₁₂
alpha-Chlorotoluene	0% Detection Frequency, All ND RLs < RIASL ₁₂
Dibromomethane	0% Detection Frequency, All ND RLs < RIASL ₁₂
Hexachlorobutadiene (HCBd)	0% Detection Frequency, All ND RLs > RIASL ₁₂
Naphthalene	0%-64% Detection Frequency, All detects & ND RLs < RIASL ₁₂

WEIGHT-OF-EVIDENCE SUMMARY

Building 304 was confirmed as a VI Path Forward Group 4A building due to its potential for VI based on a single indoor air exceedance for TCE and sub-slab soil exceedances of the draft project-specific RIASL₁₂ and/or TSRIASL₁₂ for 1,1,2-trichloroethane, 1,2-dichloroethane, 1,2-dichloropropane, carbon tetrachloride, chloroform, cis-1,2-dichloroethene, dibromochloromethane, ethylbenzene, PCE, and TCE. However, after further investigation and evaluation, the following evidence supports the conclusion that VI is insignificant at Building 304:

- No exceedances of draft project-specific screening levels in indoor air, with the exception of a single result for TCE during E1.
- The further investigation activities found low levels of TCE (all well below the screening level) and it was determined that no significant VI is currently occurring in Building 304. The TCE concentrations detected in indoor air in Building 304 are due to active workplace chemical use
- The sub-slab soil gas data do not show any strong time dependence nor do the data show any strong seasonal effects.
- The data do not support the hypothesis that wintertime should have the highest indoor air impacts. The highest sub-slab soil gas concentrations generally were measured in the summer. Similarly, the highest indoor air concentrations were measured in the spring and summer.
- The indoor air data show relatively little spatial variability, despite the greater spatial variability in the sub-slab soil gas values. This evaluation confirms that the sub-slab soil gas and indoor air concentrations were relatively constant from season to season.
- As shown in the table below, the building-specific attenuation factor yields estimated indoor air concentrations for EDB and HCBd that are less than each RIASL₁₂; however, lower reporting limits were achieved for each of these ND analytes in other events and the analytes remained ND.

Parameters	EDB	HCBd
Building-specific AF	1.00E-04	1.00E-04
Maximum reporting limit in SSSG	<150	<810
Estimated Indoor Air Concentration	0.015	0.081
Indoor Air ND RL	<0.29	<10
Indoor Air RIASL ₁₂	0.2	5.4

Based on the CSM for Building 304, VI is an insignificant exposure pathway for current building utilization.

PATH FORWARD

Based on the evaluation of the four seasonal confirmation sampling events, the VI pathway continues to be insignificant for Building 304 and the sub-slab soil gas results have demonstrated relatively stable concentrations and no evidence of increasing over time. Sufficient information exists to make a human exposure under control EI determination. However, while currently there is no evidence of potential VI, for future use, LTM is warranted and the building-specific Interim Monitoring Plan is discussed below.

Building-specific Interim Monitoring Plan

Dow implemented an interim monitoring plan for Building 304 in summer 2019, which was shared with EGLE during the May 2019 Corrective Action status meeting. Dow will implement the interim monitoring plan at Building 304 until a revised program or more permanent corrective action plan is developed for the site.

The first interim monitoring event was in August 2019. Indoor air is being monitored at location 304-IA-01 and 304-IA-02. These locations were selected for continued monitoring since they demonstrated the highest sub-slab soil gas results. Monitoring is performed for 1,1,2-trichloroethane, 1,2-dichloroethane, 1,2-dichloropropane, carbon tetrachloride, chloroform, cis-1,2-DCE, dibromochloromethane, ethylbenzene, PCE, and TCE. Interim monitoring will be performed semi-annually for a minimum of two years and monitoring results will undergo trend analysis. The screened results are shown below:

Indoor Air Analyte	Result Value (µg/m ³)	Reporting Limit (µg/m ³)	EGLE Project-Specific RIASL ₁₂ (µg/m ³)	NONRES TSRIASL ₁₂ (µg/m ³)	Dow IH OEL (8hr Time Weighted Average) (µg/m ³)
<i>Sample 304-IA-01</i>					
1,1,2-Trichloroethane	ND	0.17	0.62	NA	54,600
1,2-Dichloroethane	ND	0.12	4.6	NA	4,050
1,2-Dichloropropane	ND	0.71	12.2	NA	46,200
Carbon Tetrachloride	0.58	0.19	22	NA	1,2580
Chloroform	0.26	0.15	5.2	52	9,760
cis-1,2-Dichloroethene	ND	0.12	24	72	794,000
Dibromochloromethane	ND	1.3	5	NA	5,170
Ethyl Benzene	0.42	0.13	48	480	86,800
Naphthalene	ND	0.4	3.6	NA	52,400
Tetrachloroethene	2.6	0.21	82	82	67,800
Trichloroethene	0.18	0.16	4	12	26,850

Indoor Air Analyte	Result Value ($\mu\text{g}/\text{m}^3$)	Reporting Limit ($\mu\text{g}/\text{m}^3$)	EGLE Project-Specific RIASL ₁₂ ($\mu\text{g}/\text{m}^3$)	NONRES TSRIASL ₁₂ ($\mu\text{g}/\text{m}^3$)	Dow IH OEL (8hr Time Weighted Average) ($\mu\text{g}/\text{m}^3$)
<i>Sample 304-IA-02</i>					
1,1,2-Trichloroethane	ND	0.2	0.62	NA	54,600
1,2-Dichloroethane	ND	0.15	4.6	NA	4,050
1,2-Dichloropropane	ND	0.84	12.2	NA	46,200
Carbon Tetrachloride	0.57	0.23	22	NA	12,580
Chloroform	0.26	0.18	5.2	52	9,760
cis-1,2-Dichloroethene	ND	0.14	24	72	794,000
Dibromochloromethane	ND	1.6	5	NA	5,170
Ethyl Benzene	0.42	0.16	48	480	86,800
Naphthalene	ND	0.48	3.6	NA	52,400
Tetrachloroethene	2.5	0.25	82	82	67,800
Trichloroethene	ND	0.2	4	12	26,850

As shown in the table above, all indoor air results from the summer 2019 IM event had detected results below the RIASL₁₂ or were ND with RLs below the indoor air RIASL₁₂. The analytical data is presented in Appendix A. Field sampling forms are provided in Appendix B. The next IM event is scheduled for winter 2019/2020. Semi-annual interim monitoring will continue in the summer and winter of 2020.

Figure 304-1

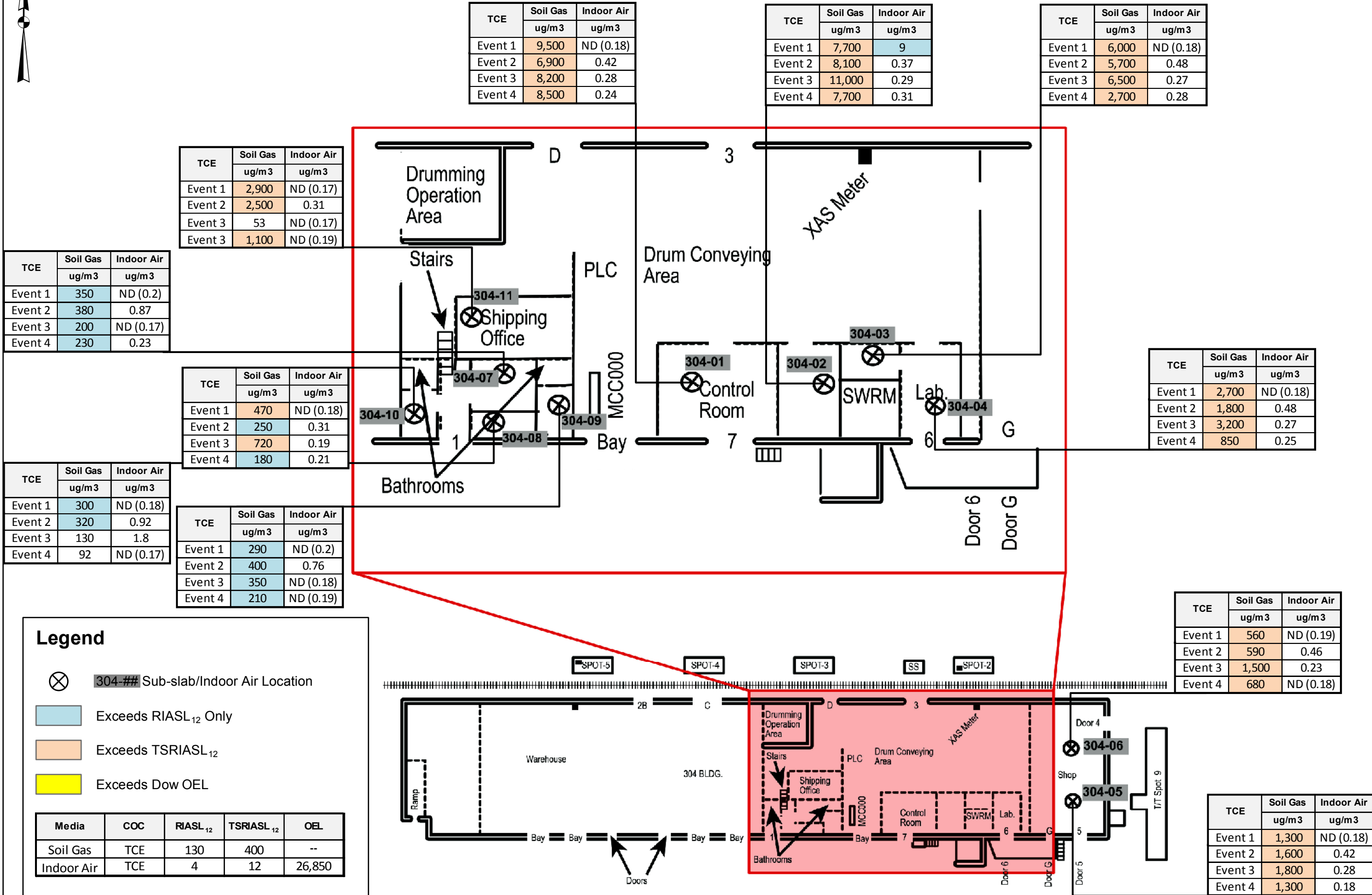

Notes:
 All units ug/m³
 Initial Sampling Event (1) = November 2017
 Seasonal Confirmation Sampling Event 2 = March 2018
 Seasonal Confirmation Sampling Event 3 = August 2018
 Seasonal Confirmation Sampling Event 4 = February 2019

Location of outdoor sample placed at intake located outside of south side of building near Door 1.

TCE	Outdoor Air Sample ug/m ³
Event 1	ND (0.18)
Event 2	ND (0.18)
Event 3	ND (0.18)
Event 4	ND (0.17)

Sub-slab Soil Gas and Indoor Air Results for Trichloroethene Zone 2 Phase 2 Sampling Events 1 - 4 Building 304

Legend

- ⊗ 304-## Sub-slab/Indoor Air Location
- Blue box: Exceeds RIASL₁₂ Only
- Orange box: Exceeds TSRIASL₁₂
- Yellow box: Exceeds Dow OEL

Media	COC	RIASL ₁₂	TSRIASL ₁₂	OEL
Soil Gas	TCE	130	400	--
Indoor Air	TCE	4	12	26,850

5.4.3 VI Seasonal Confirmation Sampling Results Evaluation for Building 499

INTRODUCTION

Building 499 is located in the southeastern quadrant of the Midland facility in Zone 2 and is known as the Demineralized Water Plant (Figure 5.4.3-1). The initial evaluation in the 2018 CAIP concluded that the TCE detected in the indoor air at Building 499 is due to indoor sources and not attributable to VI and that the VI pathway at Building 499 is an insignificant exposure pathway based on current use; however, based on the sub-slab soil gas results and given the potential for future VI, Building 499 was placed in VI Path Forward Building Group 4A. Group 4A is a designation for buildings that have sub-slab soil gas and indoor air exceedances that indicate there is a lack of correlated sample exceedances and other lines of evidence indicate that VI is insignificant and IA exceedances are likely due to routine workplace chemical use.

An Expedited Building Summary was provided for Building 499 in August 2018 based on sampling results from October 2017 and March 2018. Email updates were also provided in October 2018 and April 2019 based on the sampling results from the Summer 2018 and Winter 2019 sampling events, respectively. The evaluations concluded that the lack of correlation between the sub-slab soil gas and indoor air results suggest that VI is not the main source of indoor air detections. Therefore, a Summary of Investigative Findings documenting the further investigation activities that took place in May 2019 at Buildings 499, 564 and 827 was also provided to EGLE on July 19, 2019. Overall, the weight of evidence collected throughout that investigation confirmed that the elevated chlorinated concentrations in indoor air at Building 499 are likely due to active workplace chemical use and not attributable to VI.

The results of the first three seasonal confirmation sampling events (E1, E2 and E3) were evaluated in Section 5.3.6 of the 2018 CAIP. Since that time, the E4 sampling event was completed and the results of all four seasonal events are included in this evaluation.

Building 499	
Initial Sampling Event	Completed
E1	October 2017 (Fall)
Seasonal Sampling Event	Completed
E2	March 2018 (Spring)
E3	August 2018 (Summer)
E4	February 2019 (Winter)

Based on the evaluation of the four seasonal confirmation sampling events, the VI pathway continues to be insignificant. Sufficient information exists to make a human exposure under control EI determination.

SUB-SLAB SOIL GAS RESULTS EVALUATION

Sub-slab soil gas samples were collected from nine locations from within the building. Indoor air samples were collected at nine locations corresponding to the soil gas sample locations, along with an outdoor air sample from the main air intake. The sampling locations are shown on Figure 5.4.3-2. Summary statistics and screening comparison results are presented for sub-slab soil gas on Table 5.4.3-A and indoor and outdoor air on Table 5.4.3-B. The analytical data is presented in Appendix A. Field sampling forms are provided in Appendix B. A figure showing results for each sample location per event is provided for chloroform, PCE, and TCE since these analytes have exceedances in both sub-slab soil gas and indoor air (Figures 499-1 to 499-3). Table 499-1 presents the sub-slab soil gas results from seasonal confirmation sampling that exceed the draft project-specific screening levels.

Table 499-1. Summary of Sub-Slab Soil Gas Exceedances for Building 499

Analyte (Sampling Event)	Detection Frequency	Measured Range of Detects ($\mu\text{g}/\text{m}^3$)	% Detections > Screening Level	Screening Level* ($\mu\text{g}/\text{m}^3$)
Chloroform (1)	78%	7.9 - 570	33%	170
Chloroform (2)	78%	5.1 - 280	33%	170
Chloroform (3)	67%	7 - 240	22%	170
Chloroform (4)	44%	7.9 - 170	0%	170
cis-1,2-Dichloroethene (1)	33%	37 - 260	0%	820
cis-1,2-Dichloroethene (2)	44%	41 - 700	0%	820
cis-1,2-Dichloroethene (3)	22%	80 - 180	0%	820
cis-1,2-Dichloroethene (4)	33%	92 - 900	11%	820
Tetrachloroethene (1)	100%	32 - 32,000	78%	2,700
Tetrachloroethene (2)	100%	15 - 18,000	78%	2,700
Tetrachloroethene (3)	100%	91 - 16,000	78%	2,700
Tetrachloroethene (4)	100%	88 - 14,000	67%	2,700
Trichloroethene (1)	89%	7.6 - 3,000	78%	130
Trichloroethene (2)	78%	310 - 1,800	78%	130
Trichloroethene (3)	89%	8.8 - 2,600	78%	130
Trichloroethene (4)	89%	10 - 1,200	67%	130

*Screening level provided is the draft project-specific RIASL₁₂.

Table 499-2 summarizes the indoor air results relative to the sub-slab soil gas exceedances, since VI only potentially occurs if the analyte is present in both sub-slab soil gas and indoor air. Therefore, the table below provides the analyte detected above applicable screening levels in sub-slab soil gas as well as the corresponding indoor air sample result. The outdoor air sample result is also provided to determine if the analytes were present in indoor air due to migration from outdoor air.

Table 499-2. Vapor Intrusion Evaluation for Building 499

Analyte (Sampling Event)	Indoor Air Detection Frequency	Indoor Air Measured Range ($\mu\text{g}/\text{m}^3$)	Indoor Air Screening Level* ($\mu\text{g}/\text{m}^3$)	Outdoor Air Result ($\mu\text{g}/\text{m}^3$)
Chloroform (1)	100%	0.89 - 2	5.2	0.62
Chloroform (2)	100%	0.41 - 3.4	5.2	ND
Chloroform (3)	100%	0.22 - 9.3	5.2	0.19
Chloroform (4)	89%	1.5 - 3.8	5.2	ND
cis-1,2-Dichloroethene (1)	0%	ND	24	ND
cis-1,2-Dichloroethene (2)	100%	0.40 - 1.8	24	ND
cis-1,2-Dichloroethene (3)	67%	0.14 - 0.44	24	ND
cis-1,2-Dichloroethene (4)	0%	ND	24	ND
Tetrachloroethene (1)	100%	0.92 - 7.9	82	3.1
Tetrachloroethene (2)	100%	12 - 82	82	0.36
Tetrachloroethene (3)	100%	14 - 330	82	7.8
Tetrachloroethene (4)	100%	13 - 38	82	ND
Trichloroethene (1)	78%	0.20 - 12	4	ND
Trichloroethene (2)	100%	0.47 - 14	4	ND
Trichloroethene (3)	100%	0.40 - 43	4	0.39
Trichloroethene (4)	89%	1.8 - 12	4	ND

All indoor air results, with the exception of chloroform, PCE, and TCE, for Building 499 are below screening levels. Ethylbenzene and total xylenes were also detected in indoor air above screening levels during E4; however, all sub-slab soil gas results for these analytes were below screening levels during all events.

VAPOR INTRUSION CONCEPTUAL SITE MODEL

VI is an exposure pathway that results from the migration of volatilized chemicals from the subsurface to indoor air in overlying occupied buildings. A source, migration route and a human receptor must be present for the VI pathway to be complete. The focus of this building specific investigation is to evaluate the potential VI exposure pathway for employees and contractors at Building 499. The CSM is illustrated in Figure 5.4.3-3.

Building 499 is located in the southeastern quadrant of the Midland facility and was constructed sometime between 1938 and 1952. The 25,793 ft² structure (14,516 ft² is non-process area) is a slab-on-grade construction that is approximately three stories high in the process area. The office, lab, locker rooms/bathrooms, kitchen/break rooms, instrument shop, and control room area wrap around the process area in a single-story L shape on its northern and eastern side. This L-shaped area functions more as an annex to the process area. The building has no basement, but an elevator/lift is located in the southeast corner of the process area. The four bay doors on the building, which are all located on the south or southeastern side of the building, are predominantly left open during the summer months. The ground cover around the building is mainly asphalt with small patches of gravel and grass located to the north of the building. Railroad tracks are located just north of this gravel/grass area.

The L-shaped portion of the building that contains spaces where occupants would typically spend the bulk of their work day is heated via hot air circulation and is cooled via central AC and individual AC units. The main intake for this L-shaped area is located on the northern side of the building; however, the intake for the control room area is located in the process area. Air intakes for the process areas are located on its roof and the process area is heated via steam heat. Note that the control room floor is elevated/has a false floor to allow for various communication/utility lines to be run throughout the control room.

The occupants of Building 499 work four weekday shifts. The main shift of the day is from 7AM-2PM. The weekends have two 12-hour shifts each day. Typically, 15-20 people occupy this building during the day, four of which are operators and the others are full-time staff. The staff has access to washer/dryers located in the building. Gas-powered equipment and gasoline/fuels are typically not stored within the portion of the building where occupants reside. The typical parameters for non-residential exposures are assumed to apply to the various personnel stationed during work shifts at this building (i.e., 40 hours/week, 50 weeks/year exposure).

A building survey completed before the initial sampling event. Drains and other openings were screened with a PID and no soil gas entry points were identified. A chemical inventory was completed during the building survey that identified cleaners, insect spray, lubricant spray, anti-seize compound, and spray paint.

Further investigation activities were conducted at Building 499 in May 2019 (Summary of Investigative Findings is provided in Appendix C). The goals for the building-specific investigation for Building 499 were to gain an understanding of potential sources and distribution of TCE and PCE concentrations in the instrument shop (NW corner of the building). Baseline samples were collected at all previous indoor air and sub-slab soil gas locations, as well as at additional sample locations within the building and process area. The results of the additional sample locations led to further investigation of the process area where it was observed that several condensate trenches stretch laterally across the process area with a 5-inch diameter drain in the southeast corner connecting to the chemical sewer. Air samples collected 1-2 feet directly above the trenches and the drain had the highest concentrations of TCE. A clear concentration gradient indicated that the trenches are likely the main source of elevated chlorinated concentrations detected in the building.

The results indicate all doors connecting the process area to other parts of the building (e.g., control room, lab, eastern offices, instrument shop) allow potentially elevated concentrations of TCE and PCE to impact those areas. With the exception of the instrument shop, the rooms with poor seals into the process area, such as the lab and the control room, had the highest TCE and PCE concentrations. Doors

connecting the process area to the larger eastern office area have tight seals, and as demonstrated by this investigation as well as seasonal confirmation sampling results, there have been no indoor air exceedances in the eastern office area.

In general, very good agreement was found between TCE and PCE results, which suggests a common source for the two chemicals; however, results indicate that there are likely different sources of TCE in the instrument shop. The results of these correlations, together with the results of the trench gradient sampling, confirmed that the trenches in the process area are the main source of elevated chlorinated concentrations in indoor air and are likely due to active workplace chemical use and not attributable to VI.

Aerosol cans of Heavy Duty Flash Free Electrical Solvent (i.e., degreaser) containing over 90% TCE2 were found in the instrument shop. These cans were stored in a metal storage cabinet below a workbench and can have a localized influence on TCE concentrations in the instrument shop. A chemical/flammables storage cabinet with aerosol cans of TCE and PCE was also discovered in the process area approximately eight feet from the instrument shop's HVAC unit. A connectivity investigation was conducted since it was suspected that the proximity of the chemical/flammables storage cabinet to the instrument shop HVAC unit may influence instrument shop air. The connectivity investigation indicated that the air in the instrument shop is strongly influenced by air in the process area due to the location of the instrument shop HVAC unit.

In summary, it was determined during the further investigation activities that the connection to the site-wide chemical sewer system via the condensate trenches in the process area are the main sources of TCE and PCE concentrations in Building 499. Additionally, since the instrument shop HVAC unit is located in the process area and was shown to be leaky, the instrument shop air is shown to be heavily influenced by the air in the process area. Furthermore, aerosol cans TCE degreaser containing over 90% TCE were found in a locked metal cabinet the instrument shop and in a chemical/flammables storage cabinet adjacent to the instrument shop HVAC unit, indicating frequent workplace chemical use. Overall, the weight of evidence collected throughout the investigation confirms that the elevated chlorinated concentrations in Building 499 are likely due to active workplace chemical use and not attributable to VI.

EVALUATION OF SEASONAL CONFIRMATION SAMPLING EVENTS

Four seasonal sampling events and one interim monitoring event have been completed at Building 499. The sampling events encompass more than one year of time and include sampling during each season of the year. The results from the four seasonal confirmation sampling events were evaluated with respect to spatial variability, temporal variability, and seasonal trend analysis.

Building specific attenuation factors (α) were calculated and compared between events to evaluate temporal variability and determine the best estimate of a building-specific attenuation factor. This evaluation serves to confirm that the existing study design is appropriate, and also provides insight for the determination of the path forward for this building.

This evaluation focused on any analytes detected in the sub-slab soil gas samples that met the criterion for inclusion in one or more of the following categories:

- a) Analytes detected in sub-slab soil-gas at concentrations that exceeded draft project-specific screening levels;
- b) Analytes detected in sub-slab soil-gas at concentrations of 1,000 $\mu\text{g}/\text{m}^3$ or greater in one or more samples. Data for analytes detected above 1,000 $\mu\text{g}/\text{m}^3$ should provide the clearest signal and be the simplest to interpret when assessing data trends. The same data trends observed for

²<https://www.paintdocs.com/docs/webPDF.jsp?SITEID=SO&doctype=SDS&lang=en&prodno=075577908486&cntry=US>

these analytes are expected to apply to other similar analytes present at lower concentrations;
and

- c) Tetrachloroethene (PCE) and TCE. These two analytes are of particular interest for many VI evaluations at industrial sites.

For this building, the only analytes detected in the sub-slab soil gas at concentrations above the draft project-specific screening levels were chloroform, cis-1,2-DCE, PCE, and TCE. Four additional analytes had a detected concentration $\geq 1,000 \mu\text{g}/\text{m}^3$: 1,1,1-TCA, 1,1-DCE, CFC-12 and styrene. Due to low detection frequency or intermittent detections, three of those analytes are not included for further evaluation (1,1,1-TCA, 1,1-DCE, and styrene). CFC-12 was included for evaluation. Sample results for these analytes are provided in the following data tables below:

Summary of Results for Chloroform

Sample Type	Sample ID	Measured Concentration ($\mu\text{g}/\text{m}^3$)			
		Oct. 2017	Mar. 2018	Aug. 2018	Feb. 2019
		E1	E2	E3	E4
Outdoor Air	499-OA-01	0.62	<0.16	0.19	<0.16
Indoor Air	499-IA-01	2	0.84	0.46	3.2
	499-IA-02	1.6	0.55	0.26	2.5
	499-IA-03	1.8	0.99	0.22	2.2
	499-IA-04	1.6	0.42	0.27	<2.5
	499-IA-05	1.5	0.41	0.30	2.2
	499-IA-06	1.8	0.52	0.88	2.2
	499-IA-07	1.5	0.42	0.27	2.1
	499-IA-08	0.89	3.4	9.3	3.8
	499-IA-09	1.4	0.97	2.2	1.5
Sub-Slab Soil Gas	499-SS-01	280	230	130	100
	499-SS-02	320	240	240	85
	499-SS-03	41	36	<38	<39
	499-SS-04	<78	<38	<80	<19
	499-SS-05	570	280	190	170
	499-SS-06	<38	12	<11	<16
	499-SS-07	100	53	27	<3.8
	499-SS-08	20	5.1	8.8	7.9
	499-SS-09	7.9	<3.8	7	<3.47

Screening levels for indoor air are $5.2 \mu\text{g}/\text{m}^3$ (RIASL₁₂) and $52 \mu\text{g}/\text{m}^3$ (TSRIASL₁₂)
Screening levels for soil-gas are $170 \mu\text{g}/\text{m}^3$ (RIASL₁₂) and $1,700 \mu\text{g}/\text{m}^3$ (TSRIASL₁₂)

	RIASL12 Exceedance
	TSRIASL12 Exceedance

Summary of Results for cis-1,2-Dichloroethene (cis-1,2-DCE)

Sample Type	Sample ID	Measured Concentration ($\mu\text{g}/\text{m}^3$)			
		Oct. 2017	Mar. 2018	Aug. 2018	Feb. 2019
		E1	E2	E3	E4
Outdoor Air	499-OA-01	<0.15	<0.13	<0.13	<0.13
Indoor Air	499-IA-01	<0.12	0.45	<0.13	<0.65
	499-IA-02	<0.13	0.48	<0.13	<0.70
	499-IA-03	<0.13	1.8	0.44	<1.3
	499-IA-04	<0.14	0.42	0.17	<2
	499-IA-05	<0.13	0.43	0.18	<1.3
	499-IA-06	<0.13	0.58	0.18	<1.3
	499-IA-07	<0.14	0.40	0.14	<1.3
	499-IA-08	<0.13	0.70	0.25	<0.28
	499-IA-09	<0.11	0.40	<0.26	<0.13
Sub-Slab Soil Gas	499-SS-01	37	95	<20	92
	499-SS-02	260	250	180	330
	499-SS-03	89	700	80	900
	499-SS-04	<64	<31	<65	<16
	499-SS-05	<71	41	<58	<33
	499-SS-06	<31	<9	<8.7	<13
	499-SS-07	<31	<14	<13	<3.1
	499-SS-08	<3.3	<2.9	<3	<3.1
	499-SS-09	<3.3	<3	<3.1	<3

Screening levels for indoor air are $24 \mu\text{g}/\text{m}^3$ (RIASL₁₂) and $72 \mu\text{g}/\text{m}^3$ (TSRIASL₁₂)
Screening levels for soil-gas are $820 \mu\text{g}/\text{m}^3$ (RIASL₁₂) and $2,500 \mu\text{g}/\text{m}^3$ (TSRIASL₁₂)

Summary of Results for Tetrachloroethene (PCE)

Sample Type	Sample ID	Measured Concentration ($\mu\text{g}/\text{m}^3$)			
		Oct. 2017	Mar. 2018	Aug. 2018	Feb. 2019
		E1	E2	E3	E4
Outdoor Air	499-OA-01	3.1	0.36	7.8	<0.23
Indoor Air	499-IA-01	5.4	26	65	38
	499-IA-02	6.1	12	16	35
	499-IA-03	7.3	16	14	31
	499-IA-04	6.9	17	20	25
	499-IA-05	6.8	30	23	29
	499-IA-06	7.9	68	35	32
	499-IA-07	6.4	16	20	23
	499-IA-08	0.92	82	200	25
	499-IA-09	1.2	48	330	13
Sub-Slab Soil Gas	499-SS-01	15,000	9,200	8,300	6,000
	499-SS-02	20,000	9,600	16,000	7,000
	499-SS-03	12,000	8,700	9,200	11,000
	499-SS-04	25,000	18,000	15,000	6,400
	499-SS-05	32,000	18,000	16,000	14,000
	499-SS-06	13,000	5,500	2,900	5,700
	499-SS-07	12,000	8,800	3,900	630
	499-SS-08	340	80	91	100
	499-SS-09	32	15	250	88

Screening levels for indoor air are $82 \mu\text{g}/\text{m}^3$ (RIASL₁₂ and TSRIASL₁₂)
Screening levels for soil-gas are $2,700 \mu\text{g}/\text{m}^3$ (RIASL₁₂ and TSRIASL₁₂)

	RIASL12 Exceedance
	TSRIASL12 Exceedance

Summary of Results for Trichloroethene (TCE)

Sample Type	Sample ID	Measured Concentration ($\mu\text{g}/\text{m}^3$)			
		Oct. 2017	Mar. 2018	Aug. 2018	Feb. 2019
		E1	E2	E3	E4
Outdoor Air	499-OA-01	<0.20	<0.18	0.39	<0.18
Indoor Air	499-IA-01	0.25	0.77	0.44	<0.89
	499-IA-02	0.28	0.73	0.40	<0.95
	499-IA-03	0.35	1.4	0.46	<1.7
	499-IA-04	0.21	0.48	0.47	<2.7
	499-IA-05	0.20	0.48	0.44	<1.8
	499-IA-06	0.21	0.60	0.40	<1.8
	499-IA-07	<0.19	0.47	0.48	<1.8
	499-IA-08	<0.18	3	0.90	1.8
	499-IA-09	12	14	43	12
Sub-Slab Soil Gas	499-SS-01	650	470	440	300
	499-SS-02	3,000	1,800	2,600	930
	499-SS-03	1,500	1,700	1,800	1,200
	499-SS-04	1,700	1,100	920	390
	499-SS-05	2,300	1,100	920	880
	499-SS-06	740	310	170	280
	499-SS-07	390	310	140	10
	499-SS-08	<4.4	<4	<4.1	<4.2
	499-SS-09	7.6	<4.1	8.8	12

Screening levels for indoor air are $4 \mu\text{g}/\text{m}^3$ (RIASL₁₂) and $12 \mu\text{g}/\text{m}^3$ (TSRIASL₁₂)
Screening levels for soil-gas are $130 \mu\text{g}/\text{m}^3$ (RIASL₁₂) and $400 \mu\text{g}/\text{m}^3$ (TSRIASL₁₂)

Summary of Results for Chlorofluorocarbon (CFC-12)

Sample Type	Sample ID	Measured Concentration ($\mu\text{g}/\text{m}^3$)			
		Oct. 2017	Mar. 2018	Aug. 2018	Feb. 2019
		E1	E2	E3	E4
Outdoor Air	499-OA-01	2.2	2.6	2.3	2.7
Indoor Air	499-IA-01	8.1	4.7	3	6.4
	499-IA-02	8.1	3.8	2.5	7.3
	499-IA-03	9	3.8	2.3	9
	499-IA-04	8.4	5.3	2.5	9.7
	499-IA-05	8.8	5.7	2.6	9.8
	499-IA-06	8.8	5.8	3	10
	499-IA-07	8.8	6	2.5	10
	499-IA-08	2.8	7.5	10	6.8
	499-IA-09	3.3	4.1	8.6	4.1
Sub-Slab Soil Gas	499-SS-01	1,200	260	1,400	140
	499-SS-02	220	50	150	21
	499-SS-03	110	39	71	<40
	499-SS-04	<79	<38	<81	<19
	499-SS-05	<89	<42	<72	<42
	499-SS-06	<39	<11	30	<16
	499-SS-07	<38	<17	27	11
	499-SS-08	98	8.4	25	15
	499-SS-09	67	<3.8	84	5.3

Screening levels for indoor air are $1,020 \mu\text{g}/\text{m}^3$ (RIASL₁₂)
Screening levels for soil-gas are $34,000 \mu\text{g}/\text{m}^3$ (RIASL₁₂)

	RIASL12 Exceedance
	TSRIASL12 Exceedance

EVALUATION OF VI DATA TRENDS

Data trends for Building 499 are discussed below for both sub-slab soil gas and indoor air. When data exhibit a narrow range of variability, it is typical practice to express the range as a percentage (e.g., relative percent difference [RPD]). When data exhibit a large range of variability, however, it is more useful to express the range in orders of magnitude (i.e., factors of 10). This can be expressed mathematically as the log of the ratio of maximum/minimum values. If the values differ by a factor of 10, the log of the ratio is 1, if the values differ by a factor of 100, the log of the ratio is 2, and so on.

The variability across all locations over all sampling events is the total variability. This encompasses different types of variability, including spatial variability (i.e., how do the results vary from location to location), temporal variability (i.e., how do the results at a given location vary over time), and measurement variability. Measurement variability can be determined by evaluating results of duplicate or collocated samples and includes both sampling variability and analytical variability.

Sub-Slab Soil Gas Data Trends

Spatial Variability of Sub-Slab Soil Gas – The soil gas exhibits up to three orders of magnitude of spatial variability. For example, sub-slab soil gas detections of chloroform vary from 0.22 to 9.3 $\mu\text{g}/\text{m}^3$ (log of max./min. = 1.6) across all nine locations for E3. Sub-slab soil gas detections of PCE range from 32 to 32,000 $\mu\text{g}/\text{m}^3$ (log of max./min. = 3) across all nine locations for E1. Detected concentrations of TCE in sub-slab soil gas vary from 0.4 to 43 $\mu\text{g}/\text{m}^3$ (log max./min. = 2) across all nine location for E3. For CFC-12, sub-slab soil gas concentrations range from 25 to 1,400 $\mu\text{g}/\text{m}^3$ (log max./min. = 1.7).

Temporal Variability of Soil Gas – The soil gas concentrations exhibit up to one order of magnitude of temporal variability. For PCE, sub-slab soil gas concentrations of vary from 630 to 12,000 $\mu\text{g}/\text{m}^3$ at location 499-SS-07 (log max/min = 1.3). The PCE results for other sample locations are lower. For TCE, sub-slab soil gas concentrations of vary from 10 to 390 $\mu\text{g}/\text{m}^3$ at location 499-SS-07 (log max/min = 1.6). Sub-slab soil gas concentrations of CFC-12 vary from 8.4 to 98 $\mu\text{g}/\text{m}^3$ at location 499-SS-08 (log max/min = 1.1). Based on this evaluation, there is a relatively low amount of temporal variability in sub-slab soil gas which is in-line with expectations. Overall, as expected, the amount of temporal variability is less than the amount of spatial variability.

Seasonal Confirmation Sampling Trend Analysis – No formal statistical tests were performed, but the data exhibits consistent results between the seasons. This is demonstrated by the graph below, which shows the analytes selected above at locations where they were detected at relatively high concentrations. Note that the y-axis is a log scale.

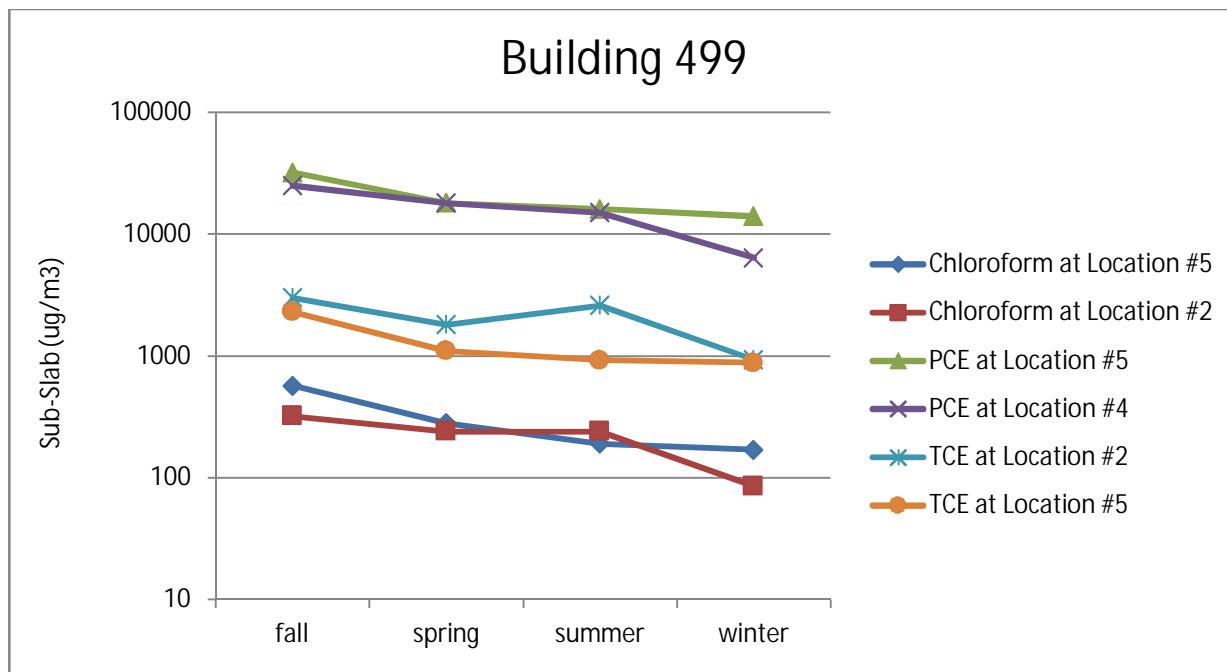

The data set was examined to see what the potential consequences would have been had only a single sampling event been performed. For PCE, TCE and chloroform the highest sub-slab soil gas concentrations were collected during the fall (E1) and the lowest concentrations occurred during the winter (E4). Therefore, implementing four seasonal confirmation sampling events provided only limited insight regarding maximum concentration levels, but the larger data set served to increase the confidence in the findings including demonstrating the consistency of the maximum reported results.

Indoor Air Data Trends

Spatial Variability of Indoor Air – The indoor air exhibits up to two orders of magnitude of spatial variability depending on the analyte. PCE was detected in all indoor air samples across the four events. During E2, indoor air concentrations varied from 14 to 330 $\mu\text{g}/\text{m}^3$ (log max./min. = 1.3). The other events saw less variability. For TCE, the highest spatial variability occurred during E1 where indoor air concentrations vary from 0.20 to 12 $\mu\text{g}/\text{m}^3$ (log max./min. = 1.8).

Temporal Variability of Indoor Air – The indoor air has, at most, one order of magnitude of temporal variability for all analytes with the exception of PCE, which exhibits two orders of magnitude. For example, indoor air concentrations of chloroform at location 499-IA-08 varied from 0.89 to 9.3 $\mu\text{g}/\text{m}^3$ (log of max./min. = 1). For PCE at location 499-IA-09, concentrations varied from 1.2 to 330 $\mu\text{g}/\text{m}^3$ (log max./min. = 2.4) but the variability is less for the remaining sample locations. Overall, temporal variability across the four seasons sampled is relatively small.

Additional Analyses

Comparison of Sub-Slab Soil Gas and Indoor Air Data Sets – As expected, the sub-slab soil gas data exhibit greater spatial variability than the indoor air data set. The sub-slab soil gas exhibits similar temporal variability to the indoor air data set. This suggests that there are indoor sources of the AOIs or that emissions from any indoor air sources tend to be well distributed in this building.

Seasonal Effects – The sub-slab soil gas data exhibit relatively little variability from event to event. Maximum sub-slab soil gas results occurred in E1 (fall) with the lowest concentrations in the winter

(E4). Maximum indoor air values occurred in E3 (summer). The data do not support the hypothesis that wintertime should have the highest indoor air impacts.

Comparison of Attenuation Factors by Event – Attenuation factors were calculated for PCE based on maximum values. The results for E3 were not used since the analytical results, supported by the findings of the further investigation, indicate that routine workplace chemical use was likely occurring at that time. The two maximum detections of PCE in E3 occurred at sample locations 499-IA-08 and 499-IA-09. These two sample locations are the only locations with detected concentrations of PCE that are all less than screening levels. The indoor air maximum concentration was corrected for contribution of outdoor air to indoor air (e.g., outdoor air detected concentration was subtracted from indoor air concentration). The calculated event-specific attenuation factors are shown in Tables 499-3.

Table 499-3. Comparison of Building-Specific Attenuation Factors for PCE by Event

	E1 (Fall)	E2 (Spring)	E3 (Summer)	E4 (Winter)
Maximum Values				
PCE in Sub-Slab Soil Gas ($\mu\text{g}/\text{m}^3$)	32000	18000	--	14000
PCE in Outdoor Air ($\mu\text{g}/\text{m}^3$)	3.1	0.36	--	ND
PCE in Indoor Air ($\mu\text{g}/\text{m}^3$)	7.9	82	--	38
PCE in Indoor Air ($\mu\text{g}/\text{m}^3$) Corrected for Outdoor Air Contribution	4.8	81.6	--	38
Attenuation Factor	1.5E-04	4.5E-03	--	2.7E-03

These serve as the best estimates of attenuation at this building. The results can vary from day to day due to differences in rates of vapor intrusion and rates of building ventilation. Overall, the most conservative estimate of a building-specific attenuation factor for Building 499 is 4.5E-03 based on PCE during E2.

Temporal Variability in Attenuation Factor – As shown in Table 499-3, there was about one order of magnitude of temporal variability in the calculated attenuation factors observed for PCE.

NON-DETECT EVALUATION

Table 499-4 below lists the analytes in sub-slab soil gas that have ND RLs greater than the screening levels. The table also includes the indoor air results for each of the analytes. If a sub-slab soil gas analyte has ND RL exceedances, but all results and ND RLs in indoor air are below the screening levels, no further evaluation is warranted. Also, if the analyte has already been identified as an AOI in sub-slab soil gas, no further ND evaluation is warranted. If an analyte was identified as an AOI in sub-slab soil gas (detected results > screening level), it is excluded from the ND evaluation. Also, if an ND analyte has an 0% detection frequency for all sampling events and all ND RLs met the screening level during at least one event, no further ND evaluation is warranted.

Table 499-4. Non-Detect Evaluation for Building 499

Soil Gas Analytes with ND RL > SL	Indoor Air Result Summary
1,1,2,2-Tetrachloroethane	0% Detection Frequency, All ND RLs < RIASL12, with the exception of E4 where 44% ND RLs < RIASL12
1,1,2-Trichloroethane	0% Detection Frequency, All ND RLs < RIASL12, with the exception of E4 where 22% ND RLs < RIASL12
1,2,4-Trichlorobenzene	0% Detection Frequency, All ND RLs < TSRIASL12, with the exception of E4 where 33% ND RLs < TSRIASL12
1,2-Dibromoethane (EDB)	0% Detection Frequency, All ND RLs > RIASL12
1,3-Dichlorobenzene	0% Detection Frequency, All ND RLs < RIASL12, with the exception of E4 where 56% ND RLs < RIASL12
2-Hexanone	0% Detection Frequency, All ND RLs < RIASL12, with the exception of E4 where 89% ND RLs < RIASL12

Table 499-4. Non-Detect Evaluation for Building 499 (Continued)

Soil Gas Analytes with ND RL > SL	Indoor Air Result Summary
alpha-Chlorotoluene	0% Detection Frequency, All ND RLs < RIASL ₁₂ , with the exception of E4 where 33% ND RLs < RIASL ₁₂
Bromodichloromethane	11% Detection Frequency, All ND RLs < RIASL ₁₂ , with the exception of E4 where 56% ND RLs < RIASL ₁₂
Bromomethane	0% Detection Frequency, All ND RLs < RIASL ₁₂ , with the exception of E4 where 56% ND RLs < RIASL ₁₂
Cumene	0% Detection Frequency, All ND RLs < RIASL ₁₂ , with the exception of E4 where 89% ND RLs < RIASL ₁₂
Dibromochloromethane	0% Detection Frequency, All ND RLs < RIASL ₁₂ , with the exception of E4 where 33% ND RLs < RIASL ₁₂
Dibromomethane	0% Detection Frequency, All ND RLs < RIASL ₁₂ , with the exception of E4 where 33% ND RLs < RIASL ₁₂
Hexachlorobutadiene (HCBd)	0% Detection Frequency, All ND RLs > RIASL ₁₂ , 78% SSSG ND RLs > RIASL ₁₂ in E2 and 67% SSSG ND RLs > RIASL ₁₂ in E4
Naphthalene	0% Detection Frequency, All ND RLs < RIASL ₁₂ , with the exception of E4 where 44% ND RLs < RIASL ₁₂

WEIGHT-OF-EVIDENCE SUMMARY

Building 499 was confirmed as a VI Path Forward Group 4A building due to its potential for VI based on sub-slab soil exceedances of the draft project-specific RIASL₁₂ and/or TSRIASL₁₂ for chloroform, cis-1,2-dichloroethene, PCE, and TCE. However, after further investigation and evaluation, the following evidence supports the conclusion that VI is insignificant at Building 499:

- The sub-slab soil gas results indicate that concentrations are stable or decreasing.
- The sub-slab soil gas data do not show any strong time dependence nor do the data show any strong seasonal effects.
- The data do not support the hypothesis that wintertime should have the highest indoor air impacts. The highest sub-slab soil gas concentrations generally were measured in the fall. The highest indoor air concentrations were measured in the summer.
- Overall, the weight of evidence collected throughout the investigation confirms that the elevated chlorinated concentrations in Building 499 are likely due to active workplace chemical use and not attributable to VI:
 - Further investigation activities identified the connection to the site-wide chemical sewer system via condensate trenches in the process area as the main sources of TCE and PCE concentrations;
 - The instrument shop HVAC unit is located in the process area and was shown to be leaky and heavily influencing the indoor air within the instrument shop.
 - Aerosol cans TCE degreaser containing over 90% TCE were found in a locked metal cabinet the instrument shop and in a chemical/flammables storage cabinet adjacent to the instrument shop HVAC unit, indicating frequent workplace chemical use.
- The indoor air data show relatively little spatial variability, despite the greater spatial variability in the sub-slab soil gas values. This evaluation confirms that the sub-slab soil gas and indoor air concentrations were relatively constant from season to season.

- As shown in the table below, the building-specific attenuation factor yields estimated indoor air concentration for HCBd below the RIASL₁₂. For EDB, the maximum ND RL (< 140 µg/m³) occurred at location 499-SS-05 during E1 and lower reporting limits were achieved during all other events. If the ND RL from E4 is used (64 µg/m³), the estimated indoor air concentration (0.29 µg/m³) is only slightly above the screening level.

Parameters	EDB	HCBd
Building-specific AF	4.5E-03	4.5E-03
Maximum reporting limit in SSSG	<64	<760
Estimated Indoor Air Concentration	0.29	3.4
Indoor Air ND RL	<0.26	<8.8
Indoor Air RIASL ₁₂	0.2	5.4

Based on the CSM for Building 499, VI is an insignificant exposure pathway for current building utilization.

PATH FORWARD

Based on the evaluation of the four seasonal confirmation sampling events, the VI pathway continues to be insignificant for Building 499 and the sub-slab soil gas results have demonstrated relatively stable concentrations and no evidence of increasing over time. Sufficient information exists to make a human exposure under control EI determination. However, while currently there is no evidence of potential VI, for future use, LTM is warranted and the building-specific Interim Monitoring Plan is discussed below.

Building-specific Interim Monitoring Plan

Dow implemented an interim monitoring plan for Building 499 in summer 2019, which was shared with EGLE during the May 2019 Corrective Action status meeting. Dow will implement the interim monitoring plan at Building 499 until a revised program or more permanent corrective action plan is developed for the site.

Indoor air is being monitored at locations 499-IA-02, 499-IA-05, and 499-IA-09. These locations were selected for continued monitoring since they demonstrated the highest sub-slab soil gas results. These locations were selected for continued monitoring since it demonstrated the highest sub-slab soil gas results. Monitoring will be performed for chloroform, cis-1,2-dichloroethene, PCE, and TCE. Interim monitoring will be performed semi-annually for a minimum of two years and monitoring results will undergo trend analysis. The screened results are shown below:

Indoor Air Analyte	Result Value (µg/m ³)	Reporting Limit (µg/m ³)	EGLE Project-Specific RIASL ₁₂ (µg/m ³)	NONRES TSRIASL ₁₂ (µg/m ³)	Dow IH OEL (8hr Time Weighted Average) (µg/m ³)
<i>Sample 499-IA-02</i>					
Chloroform	1.6	0.16	5.2	52	9,760
cis-1,2-Dichloroethene	1.2	0.13	24	72	794,000
PCE	55	0.23	82	82	67,800
TCE	0.7	0.18	4	12	26,850
<i>Sample 499-IA-05</i>					
Chloroform	1.1	0.16	5.2	52	9,760
cis-1,2-Dichloroethene	1	0.13	24	72	794,000
PCE	46	0.23	82	82	67,800
TCE	0.54	0.18	4	12	26,850

Indoor Air Analyte	Result Value (µg/m³)	Reporting Limit (µg/m³)	EGLE Project-Specific RIASL₁₂ (µg/m³)	NONRES TSRIASL₁₂ (µg/m³)	Dow IH OEL (8hr Time Weighted Average) (µg/m³)
<i>Sample 499-IA-09</i>					
Chloroform	2.9	0.17	5.2	52	9,760
cis-1,2-Dichloroethene	0.14	0.13	24	72	794,000
PCE	8.9	0.23	82	82	67,800
TCE	0.18	0.18	4	12	26,850

As shown in the table above, all indoor air results from the summer 2019 IM event had detected results below the RIASL₁₂. The analytical data is presented in Appendix A. Field sampling forms are provided in Appendix B. The next IM event is scheduled for winter 2019/2020. Semi-annual interim monitoring will continue in the summer and winter of 2020.



Figure 499-1

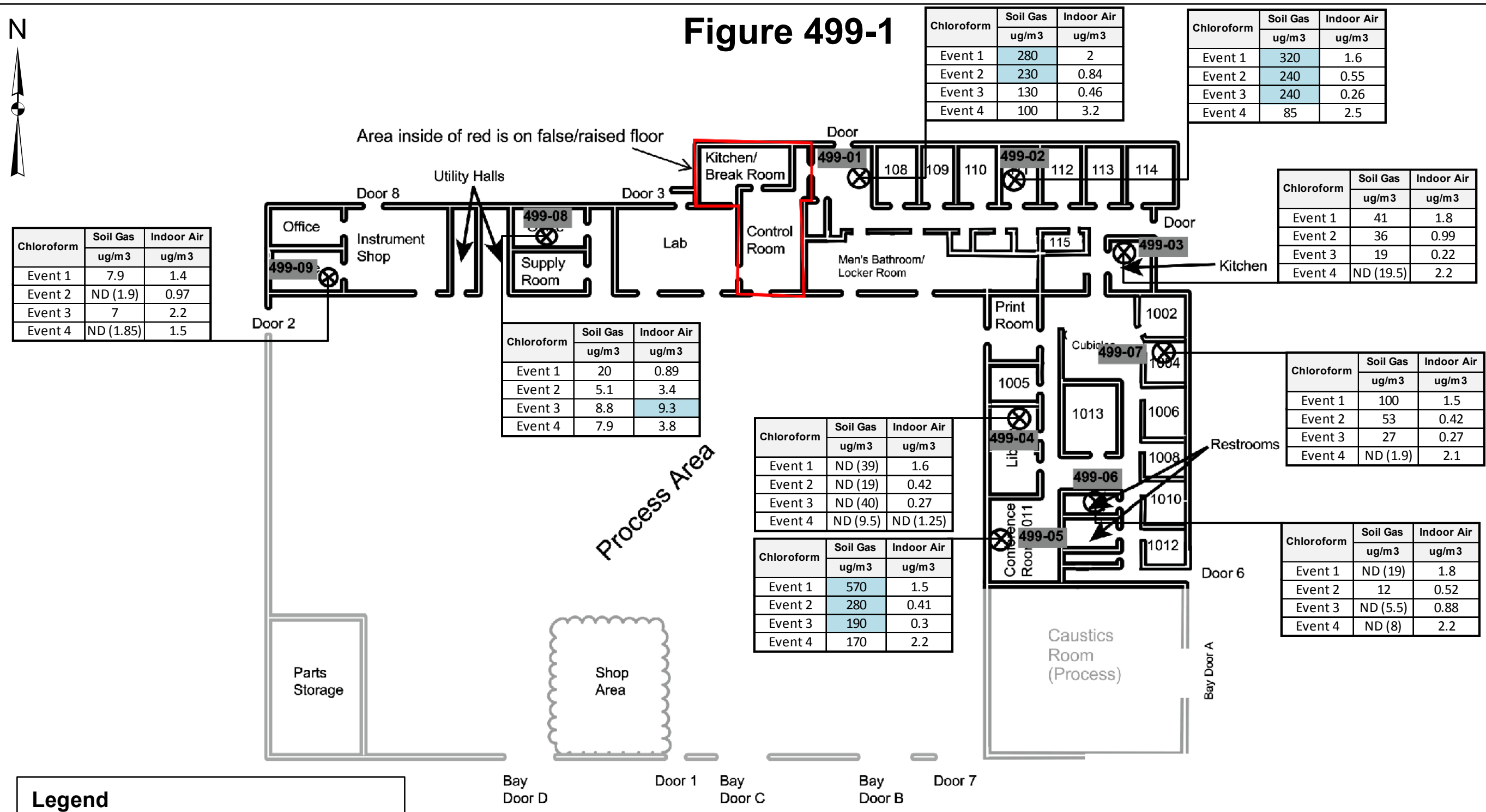

Chloroform	Soil Gas	Indoor Air
	ug/m ³	ug/m ³
Event 1	7.9	1.4
Event 2	ND (1.9)	0.97
Event 3	7	2.2
Event 4	ND (1.85)	1.5

Chloroform	Soil Gas	Indoor Air
	ug/m ³	ug/m ³
Event 1	280	2
Event 2	230	0.84
Event 3	130	0.46
Event 4	100	3.2

Chloroform	Soil Gas	Indoor Air
	ug/m ³	ug/m ³
Event 1	320	1.6
Event 2	240	0.55
Event 3	240	0.26
Event 4	85	2.5

Chloroform	Soil Gas	Indoor Air
	ug/m ³	ug/m ³
Event 1	41	1.8
Event 2	36	0.99
Event 3	19	0.22
Event 4	ND (19.5)	2.2

Chloroform	Soil Gas	Indoor Air
	ug/m ³	ug/m ³
Event 1	20	0.89
Event 2	5.1	3.4
Event 3	8.8	9.3
Event 4	7.9	3.8

Chloroform	Soil Gas	Indoor Air
	ug/m ³	ug/m ³
Event 1	ND (39)	1.6
Event 2	ND (19)	0.42
Event 3	ND (40)	0.27
Event 4	ND (9.5)	ND (1.25)

Chloroform	Soil Gas	Indoor Air
	ug/m ³	ug/m ³
Event 1	570	1.5
Event 2	280	0.41
Event 3	190	0.3
Event 4	170	2.2

Chloroform	Soil Gas	Indoor Air
	ug/m ³	ug/m ³
Event 1	100	1.5
Event 2	53	0.42
Event 3	27	0.27
Event 4	ND (1.9)	2.1

Chloroform	Soil Gas	Indoor Air
	ug/m ³	ug/m ³
Event 1	ND (19)	1.8
Event 2	12	0.52
Event 3	ND (5.5)	0.88
Event 4	ND (8)	2.2

Legend

- ⊗ 499-## Sub-slab/Indoor Air Location
- Exceeds RIASL₁₂ Only
- Exceeds TSRIASL₁₂
- Exceeds Dow OEL

Media	COC	RIASL ₁₂	TSRIASL ₁₂	OEL
Soil Gas	Chloroform	170	1,700	--
Indoor Air	Chloroform	5.2	52	9,760

Notes:

All units ug/m³

Initial Sampling Event (1) = October 2017

Seasonal Confirmation Sampling Event 2 = March 2018

Seasonal Confirmation Sampling Event 3 = August 2018

Seasonal Confirmation Sampling Event 4 = February 2019

Location of outdoor air sample placed at Intake location outside of Office 110 on north side of building.

Chloroform	Outdoor Air Sample ug/m ³
Event 1	0.62
Event 2	ND (0.08)
Event 3	0.19
Event 4	ND (0.08)

Sub-slab Soil Gas and Indoor Air Results for Chloroform Zone 2 Phase 1 Sampling Events 1 - 4 Building 499





Figure 499-3

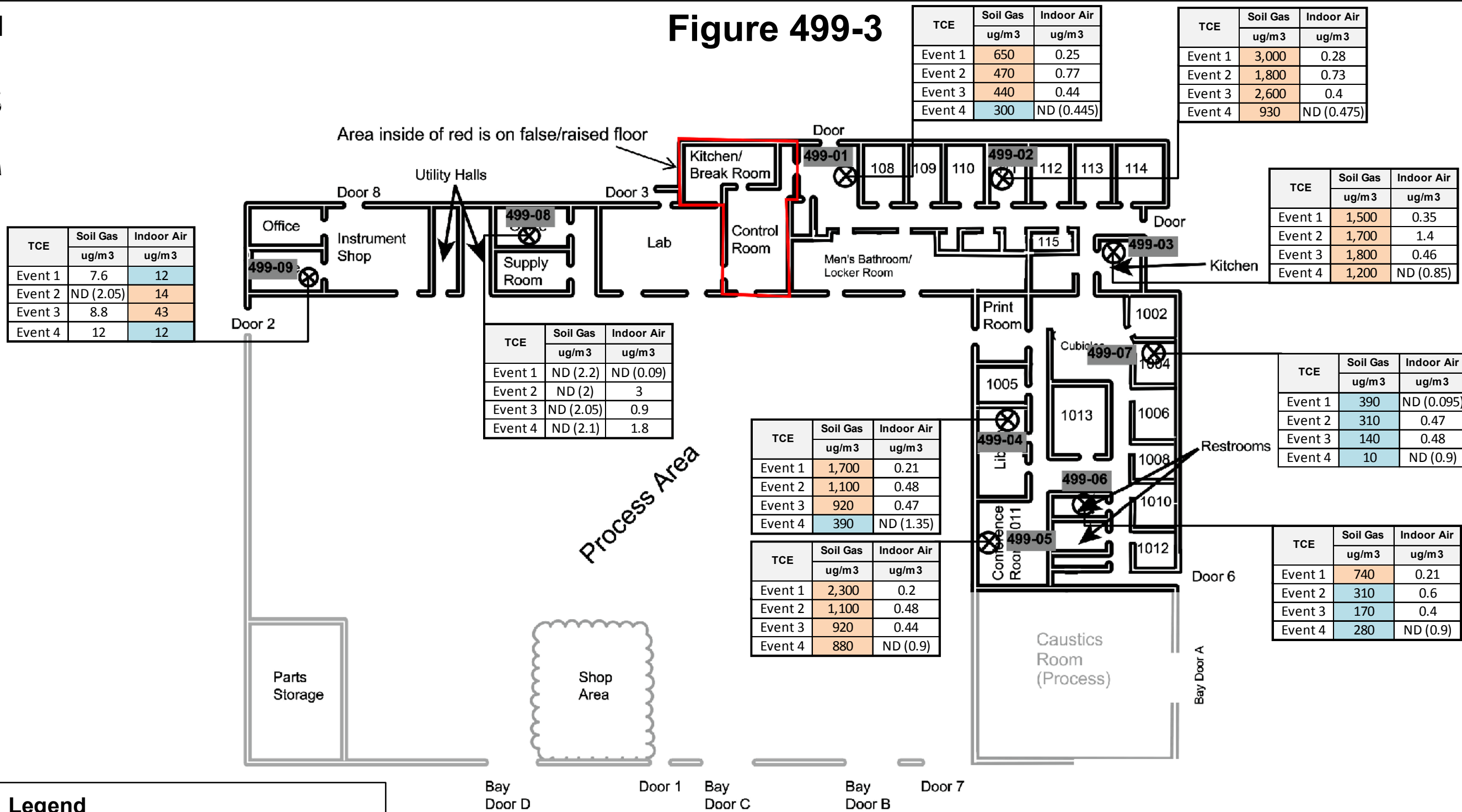

TCE	Soil Gas ug/m3	Indoor Air ug/m3
Event 1	7.6	12
Event 2	ND (2.05)	14
Event 3	8.8	43
Event 4	12	12

TCE	Soil Gas ug/m3	Indoor Air ug/m3
Event 1	650	0.25
Event 2	470	0.77
Event 3	440	0.44
Event 4	300	ND (0.445)

TCE	Soil Gas ug/m3	Indoor Air ug/m3
Event 1	3,000	0.28
Event 2	1,800	0.73
Event 3	2,600	0.4
Event 4	930	ND (0.475)

TCE	Soil Gas ug/m3	Indoor Air ug/m3
Event 1	1,500	0.35
Event 2	1,700	1.4
Event 3	1,800	0.46
Event 4	1,200	ND (0.85)

TCE	Soil Gas ug/m3	Indoor Air ug/m3
Event 1	ND (2.2)	ND (0.09)
Event 2	ND (2)	3
Event 3	ND (2.05)	0.9
Event 4	ND (2.1)	1.8

TCE	Soil Gas ug/m3	Indoor Air ug/m3
Event 1	1,700	0.21
Event 2	1,100	0.48
Event 3	920	0.47
Event 4	390	ND (1.35)

TCE	Soil Gas ug/m3	Indoor Air ug/m3
Event 1	2,300	0.2
Event 2	1,100	0.48
Event 3	920	0.44
Event 4	880	ND (0.9)

TCE	Soil Gas ug/m3	Indoor Air ug/m3
Event 1	390	ND (0.095)
Event 2	310	0.47
Event 3	140	0.48
Event 4	10	ND (0.9)

TCE	Soil Gas ug/m3	Indoor Air ug/m3
Event 1	740	0.21
Event 2	310	0.6
Event 3	170	0.4
Event 4	280	ND (0.9)

Legend

⊗ 499-## Sub-slab/Indoor Air Location

Exceeds RIASL₁₂ Only

Exceeds TSRIASL₁₂

Exceeds Dow OEL

Media	COC	RIASL ₁₂	TSRIASL ₁₂	OEL
Soil Gas	TCE	130	400	--
Indoor Air	TCE	4	12	26,850

Notes:
 All units ug/m3
 Initial Sampling Event (1) = October 2017
 Seasonal Confirmation Sampling Event 2 = March 2018
 Seasonal Confirmation Sampling Event 3 = August 2018
 Seasonal Confirmation Sampling Event 4 = February 2019
 Location of outdoor air sample placed at Intake location outside of Office 110 on north side of building.

TCE	Outdoor Air Sample ug/m3
Event 1	ND (0.1)
Event 2	ND (0.09)
Event 3	0.39
Event 4	ND (0.09)

Sub-slab Soil Gas and Indoor Air Results for Trichloroethene Zone 2 Phase 1 Sampling Events 1 - 4 Building 499

5.4.4 VI Seasonal Confirmation Sampling Results Evaluation for Building 593

INTRODUCTION

Building 593 is a Category 2 building located in the southeastern quadrant of the Midland facility and is known as the Fabrication Shop (Figure 5.4.4-1). The building was constructed sometime between 1938 and 1952. The 95,544 ft² structure is a slab-on-grade L-shaped construction that is approximately three stories high. The L-shaped portion of the building is predominantly a large fabrication shop containing a variety of different work areas that is used by various contractors. A single-story annex containing office space, locker rooms, storage, a conference room, and a large kitchen/break room is located to the southwest of the inside corner of the L-shaped fabrication shop area. The initial evaluation in the 2018 CAIP placed Building 593 in VI Path Forward Group 4A as lines of evidence indicate that VI is insignificant and the indoor air exceedances are likely due to workplace chemical use. The results from E1 and E2 were re-evaluated in the 2018 Rescreen Report and in Section 5.3.3 of the 2018 CAIP.

An Expedited Building Summary was submitted for Building 593 on August 24, 2018 as MDEQ requested expedited reporting if an indoor air result exceeds the TSRIASL₁₂. Therefore, each indoor air result was compared to the TSRIASL₁₂ from the August 2017 Media-Specific Volatilization to Indoor Air Interim Action Screening Levels. PCE was the only analyte in indoor air detected at Building 593 greater than the TSRIASL₁₂. The findings summarized in the expedited building summary concluded that the PCE detected in the indoor air at Building 593 is due to indoor sources and not attributable to VI. The indoor air results suggest a common source, such as work within the shop and spare parts area in the northwest corner of the building involving degreasers or other products. Therefore, interim response actions were not necessary to address the detections of PCE in indoor air at Building 593 and seasonal confirmation sampling continued. Since that time, three additional seasonal events (E3, E4, and E5) and an in-depth further investigation using mobile GC analysis have been completed. Additionally, email updates regarding were provided to EGLE in April and July 2019. The results of all completed events are summarized and included in this evaluation.

Building 593	
Initial Sampling Event	Completed
E1	November 2017 (Fall)
Seasonal Sampling Event	Completed
E2 (Limited Event)	March/April 2018 (Spring)
E3	August 2018 (Summer)
E4	February 2019 (Winter)
E5	April 2019 (Spring)

1,2-Dichloroethane, chloroform, PCE, and TCE had exceedances of the indoor air RIASL₁₂ and/or TSRIASL₁₂ during the initial event (E1). PCE was the only indoor air analyte with an exceedance during E2. All of the indoor air results were below screening levels during E3 and E4. During E5, 1,2,4-TMB, naphthalene had exceedances at a single sample location and PCE had exceedances at two sample locations.

SUB-SLAB SOIL GAS RESULTS EVALUATION

Building 593 has undergone a total of five seasonal confirmation sampling events. For E1 and E3, sub-slab soil gas samples were collected from 38 of the 39 locations from within the building (an in-shipment sampling can failure for the sub-slab sample from location 593-29 during E1 resulted in the recollecting taking place in the winter season/outside the seasonal scope of E1). Indoor air samples were collected at 39 locations corresponding to the soil gas sample locations, along with an outdoor air sample from the main air intake. The sampling locations for E1 and E3 are shown on Figure 5.4.4-2. For the limited event (E2), sub-slab soil gas and indoor air samples were collected from 16 locations from within the building, along with an outdoor air sample from the main air intake. The sampling locations for E2 are shown on

Figure 5.4.4-3. Based on the results from the first three sampling events, a subset of 20 of the original 39 locations were identified as warranting inclusion in subsequent sampling events E4 and E5. The sampling locations for E4 and E5 are also shown in Figure 5.4.4-2. Sub-slab soil gas and indoor air results for each sample location and sampling event is provided for chloroform, TCE, and PCE on Figures 593-1 through 593-3. Summary statistics and screening comparison results are presented for sub-slab soil gas on Table 5.4.4-A and indoor and outdoor air on Table 5.4.4-B. The analytical data is presented in Appendix A. Field sampling forms are provided in Appendix B. Table 593-1 presents the sub-slab soil gas results that exceed the draft project-specific screening levels.

Table 593-1. Summary of Sub-Slab Soil Gas Exceedances for Building 593

Analyte (Sampling Event)	Detection Frequency	Measured Range of Detects ($\mu\text{g}/\text{m}^3$)	% Detections > Screening Level	Screening Level* ($\mu\text{g}/\text{m}^3$)
1,1,2-Trichloroethane (1)	24%	7 - 27	3%	20
1,1,2-Trichloroethane (2)	44%	5.3 - 73	13%	20
1,1,2-Trichloroethane (3)	8%	9.3 - 31	5%	20
1,1,2-Trichloroethane (4)	5%	23	5%	20
1,1,2-Trichloroethane (5)	5%	18	0%	20
1,2-Dichloropropane (1)	24%	4.2 - 98	0%	410
1,2-Dichloropropane (2)	50%	5.2 - 430	6%	410
1,2-Dichloropropane (3)	21%	5.9 - 73	0%	410
1,2-Dichloropropane (4)	25%	3.7 - 73	0%	410
1,2-Dichloropropane (5)	20%	4.9 - 82	0%	410
Chloroform (1)	71%	4 - 180	3%	170
Chloroform (2)	81%	4.6 - 93	0%	170
Chloroform (3)	82%	5.2 - 630	5%	170
Chloroform (4)	80%	4.2 - 140	0%	170
Chloroform (5)	65%	7.2 - 160	0%	170
Hexachlorobutadiene (1)	42%	56 - 2,800	29%	180
Hexachlorobutadiene (2)	81%	65 - 6,100	63%	180
Hexachlorobutadiene (3)	46%	41 - 6,400	26%	180
Hexachlorobutadiene (4)	35%	32 - 1,500	10%	180
Hexachlorobutadiene (5)	25%	59 - 2,300	10%	180
Tetrachloroethene (1)	100%	14 - 54,000	16%	2,700
Tetrachloroethene (2)	100%	17 - 1,400	0%	2,700
Tetrachloroethene (3)	100%	26 - 54,000	23%	2,700
Tetrachloroethene (4)	100%	250 - 24,000	25%	2,700
Tetrachloroethene (5)	100%	54 - 30,000	30%	2,700
Trichloroethene (1)	59%	5.3 - 1,500	24%	130
Trichloroethene (2)	56%	33 - 3,300	38%	130
Trichloroethene (3)	72%	5.4 - 2,400	26%	130
Trichloroethene (4)	75%	11 - 940	45%	130
Trichloroethene (5)	80%	4.1 - 650	35%	130

*Screening level provided is the draft project-specific RIASL₁₂.

Table 593-2 summarizes the indoor air results relative to the sub-slab soil gas exceedances, since VI only potentially occurs if the analyte is present in both sub-slab soil gas and indoor air. Therefore, the table below provides the analytes detected above applicable screening levels in sub-slab soil gas as well as the corresponding indoor air sample results. The outdoor air sample results are also provided to determine if the analytes were present in indoor air due to migration from outdoor air.

Table 593-2. Vapor Intrusion Evaluation for Building 593

Analyte (Sampling Event)	Indoor Air Detection Frequency	Indoor Air Measured Range ($\mu\text{g}/\text{m}^3$)	Indoor Air Screening Level* ($\mu\text{g}/\text{m}^3$)	Outdoor Air Result ($\mu\text{g}/\text{m}^3$)
1,1,2-Trichloroethane (1)	13%	0.25 - 0.34	0.62	ND
1,1,2-Trichloroethane (2)	0%	ND	0.62	ND
1,1,2-Trichloroethane (3)	0%	ND	0.62	ND
1,1,2-Trichloroethane (4)	0%	ND	0.62	ND
1,1,2-Trichloroethane (5)	0%	ND	0.62	ND
1,2-Dichloropropane (1)	0%	ND	12.2	ND
1,2-Dichloropropane (2)	0%	ND	12.2	ND
1,2-Dichloropropane (3)	0%	ND	12.2	ND
1,2-Dichloropropane (4)	0%	ND	12.2	ND
1,2-Dichloropropane (5)	0%	ND	12.2	ND
Chloroform (1)	87%	0.17 - 14	5.2	ND
Chloroform (2)	88%	0.22 - 1.9	5.2	ND
Chloroform (3)	44%	0.29 - 5.2	5.2	ND
Chloroform (4)	40%	0.16 - 1.1	5.2	ND
Chloroform (5)	85%	0.16 - 4.2	5.2	ND
Hexachlorobutadiene (1)	0%	ND	5.4	ND
Hexachlorobutadiene (2)	0%	ND	5.4	ND
Hexachlorobutadiene (3)	0%	ND	5.4	ND
Hexachlorobutadiene (4)	0%	ND	5.4	ND
Hexachlorobutadiene (5)	0%	ND	5.4	ND
Tetrachloroethene (1)	100%	3.6 - 830	82	0.53
Tetrachloroethene (2)	100%	2.9 - 260	82	ND
Tetrachloroethene (3)	67%	0.23 - 7.5	82	ND
Tetrachloroethene (4)	100%	0.48 - 11	82	ND
Tetrachloroethene (5)	100%	1 - 110	82	ND
Trichloroethene (1)	62%	0.22 - 8.2	4	ND
Trichloroethene (2)	44%	0.18 - 0.86	4	ND
Trichloroethene (3)	8%	0.20 - 0.22	4	ND
Trichloroethene (4)	15%	0.18 - 0.23	4	0.43
Trichloroethene (5)	70%	0.19 - 2.6	4	ND

*Screening level provided is the draft project-specific RIASL₁₂.

PCE was the only analyte detected in indoor air above its TSRIASL₁₂, which is the same as the RIASL₁₂ (i.e., 82 $\mu\text{g}/\text{m}^3$). Note that there were no correlated sample locations where screening levels for PCE were exceeded in both indoor air and sub-slab soil gas. PCE exceeded the indoor air TSRIASL₁₂ at 14 out of 39 sample locations during E1. During the subsequent four sampling events, exceedances were observed at one location during E2 (593-IA-10b) and at two locations during E5 (593-IA-17 and 593-IA-18). There were no PCE indoor air exceedances during E3 or E4.

The highest PCE concentrations in the indoor air occurred at locations 593-IA-17 through 593-IA-19 during E1 and locations 593-IA-17 and 593-IA-18 were the only locations with exceedances observed greater than the TSRIASL₁₂ in more than one event. The indoor air sample locations with exceedances tended to be clustered together in two areas: the western most area of the fabrication shop and in the central area surrounding the carpenter shop, tool crib, storage area, and men's locker room. The highest PCE concentrations in the sub-slab soil gas samples occurred at locations 593-SS-20 through 593-SS-34 with locations 593-SS-20, 593-SS-30, and 593-SS-34 being the only sub-slab soil gas locations with PCE results exceeding the RIASL₁₂/TSRIASL₁₂ during all the events they were sampled. The lack of correlation between the sub-slab soil gas values and the indoor air values, together with the size of the building, suggests that the concentrations of PCE detected in indoor air are not likely attributable to VI. The maximum result of PCE detected in indoor air at Building 593 is 830 $\mu\text{g}/\text{m}^3$, which is <2% of the Dow OEL.

TCE and chloroform were also detected at concentrations greater than their respective indoor air RIASL₁₂ values ($4 \mu\text{g}/\text{m}^3$ and $5.2 \mu\text{g}/\text{m}^3$, respectively) during E1 at locations within and immediately adjacent to the men's locker room; however, these were the only TCE and chloroform indoor air RIASL₁₂ exceedances over the course of the five sampling events. Sub-slab soil gas chloroform detections only exceeded the RIASL₁₂ values once during E1 at 593-SS-17 and twice during E3 at 593-SS-02 and 593-SS-08. There were multiple exceedances of TCE sub-slab soil gas RIASL₁₂ and TSRIASL₁₂ during E1 through E5, but only seven locations saw exceedances of at least the RIASL₁₂ value during all events in which they were sampled: 593-SS-13, 593-SS-17, 593-SS-18, 593-SS-20, 593-SS-22, 593-SS-23, and 593-SS-30. Six of these seven locations are found within either the men's locker room, lunch room, or carpenter shop/storage area located in the annex and only one of these locations (593-SS-30) is located in the large bay area. Again, the lack of correlation between sub-slab soil gas values and indoor air values together with the size of the building (e.g., lateral separation between locations with sub-slab soil gas exceedances and locations with indoor air exceedances) suggests that VI is not likely the source of the indoor air detections observed of chloroform and TCE. The maximum results for TCE ($8.2 \mu\text{g}/\text{m}^3$) and chloroform ($14 \mu\text{g}/\text{m}^3$) detected in indoor air at Building 593 are 0.03% and 0.14% of their respective OELs.

An additional investigation was undertaken at Building 593 in October 2019 and was reported in the January 2020 Summary of Investigative Findings (see Appendix C) which made use of a field GC capable of detecting TCE at relatively low concentrations. While the analytical method was optimized for TCE, the approach also provided data for PCE and chloroform. Workplace sources of PCE, and TCE were discovered during this investigation (e.g., degreasers containing 80+% of either PCE or TCE). Chloroform concentrations observed appear to be trending based on the location of treated municipal water in the building, a known source of chloroform and other trihalomethanes. Although TCE continues to be detected in indoor air throughout this investigation, results are comparatively low.

Detections of PCE occurred in a hallway, very near and underneath lockers, outside the men's locker room (near location 593-14). While this location is next to double doors that are frequently opened from the outside bay and shop area, when a sample from this location was taken simultaneously with 593-17 (inside the men's locker room) the two results were almost identical. Approximately 15 feet away from 593-14 is the HVAC system filter for the men's locker room and surrounding insulated areas. This could explain the detected PCE concentrations in the men's locker room since the HVAC spreads air from the hallway throughout this part of the building. Furthermore, samples collected during the day had lower concentrations than samples collected at night, as frequent door openings during work hours creates higher air turnover.

The area underneath the lockers in the hallway (593-14) appears to be a potential pathway, though not necessarily a conduit for PCE. The lockers are bolted in place and currently inaccessible for direct sampling; however, it is important to note, all results from the mobile GC investigation are less than the RIASL₁₂ screening values for chloroform, PCE, and TCE.

VAPOR INTRUSION CONCEPTUAL SITE MODEL

VI is an exposure pathway that results from the migration of volatilized chemicals from the subsurface to indoor air in overlying occupied buildings. A source, migration route and a human receptor must be present for the VI pathway to be complete. The focus of this evaluation is to evaluate the potential VI exposure pathway for employees and contractors at Building 593. The CSM is illustrated on Figure 5.4.4-4.

The 95,544 ft² structure is a slab-on-grade L-shaped construction that is approximately three stories high. The building has no basement and no elevators. The L-shaped portion of the building is predominantly a large fabrication shop containing a variety of different work areas that is used by both Dow employees and various contractors. The longer portion of the L-shaped building has an east-west orientation with the shorter portion of the L-shape north-south oriented. A single-story annex containing office space, locker rooms, storage, a conference room, and a large kitchen/break room is located to the southwest of

the inside corner of the L-shaped fabrication shop area. The ground cover around the building consists of asphalt.

During the week, 50 to 100 people come through the building to work, take a break, or attend meetings. During the weekend, roughly 25 to 30 people may come through the structure to do similar activities. The locker room does have washer/dryers, but most work clothes used by the occupants are cleaned by a contracted laundry service. Gas-powered equipment and gasoline/fuels are stored throughout the building, but mainly in the large shop area. The typical parameters for non-residential exposures are assumed to apply to the various personnel stationed during rotating work shifts at this building (i.e., 40 hours/week, 50 weeks/year exposure).

In the office annex, the air is heated via hot air circulation/forced air. In the shop area there are unit heaters suspended from the ceiling. The office annex is cooled through a combination of central AC and individual AC units. The locker rooms and bathrooms have ventilation fans. There are also large mechanical fans used in the shop area that are typically used in conjunction with opened bay doors. The structure has nine bay doors that are shut on the weekend, but are otherwise opened, particularly during the warmer months. Fume extractors located near multiple work benches are often used for ventilation purposes while welding work is completed in the shop area. Two air handlers for the office annex are located on its roof and there are multiple exhaust fans/vents located on the roof of the shop area.

The building survey completed before the initial sampling event. Drains, washrooms, drums and other openings were screened with a PID and the only PID reading observed (1.8 ppm) during the time of the survey was from the ambient air near a flammable cabinet found in the southeastern corner of the building near Bay J. The chemical inventory performed during the building survey identified hundreds of potential indoor emission sources. The inventory indicated that the chemicals of interest are stored and/or used within the building. For example:

- CRC Heavy Duty Degreaser MUO contains 80 - 90% PCE;
- Sprayon EL848 Flash Free Electrical Degreaser contains 97.5% TCE; and
- CRC Cable Clean Degreaser contains 90 - 100% 1-bromopropane.

EVALUATION OF SEASONAL CONFIRMATION SAMPLING EVENTS

Building 593 has undergone a total of five seasonal confirmation sampling events; however, the second event was a limited event to further investigate the area surrounding the indoor air exceedances of PCE observed during E1. The sampling events include sampling during each season of the year. The results from the seasonal confirmation sampling events were evaluated with respect to spatial variability, temporal variability, and seasonal trend analysis.

Building specific attenuation factors (α) were calculated and compared between events to evaluate temporal variability and determine the best estimate of a building-specific attenuation factor. This evaluation serves to confirm that the existing study design is appropriate, and also provides insight for the determination of the path forward for this building.

This evaluation focused on any analytes detected in the sub-slab soil gas samples that met the criterion for inclusion in one or more of the following categories:

- a) Analytes detected in sub-slab soil-gas at concentrations that exceeded draft project-specific screening levels;
- b) Analytes detected in sub-slab soil-gas at concentrations of 1,000 $\mu\text{g}/\text{m}^3$ or greater in one or more samples. Data for analytes detected above 1,000 $\mu\text{g}/\text{m}^3$ should provide the clearest signal and be the simplest to interpret when assessing data trends. The same data trends observed for

these analytes are expected to apply to other similar analytes present at lower concentrations;
and

- c) PCE and TCE. These two analytes are of particular interest for many VI evaluations at industrial sites.

For this building, the analytes detected in the sub-slab soil gas at concentrations above the draft project-specific screening levels were 1,1,2-TCA, 1,2-DCP, chloroform, HCBd, PCE, and TCE. For Building 593, PCE and TCE are the only analytes with sub-slab soil gas results >1,000 µg/m³ in addition to having observed exceedances of their respective RIASL₁₂/TSRIASL₁₂ values. Sample results for these two analytes are provided in the following data tables below:

Summary of Results for Tetrachloroethene (PCE)

Sample Type	Sample ID	Measured Concentration (µg/m ³)				
		Nov 2017	Mar 2018	Aug. 2018	Feb. 2019	Apr 2019
		E1	E2	E3	E4	E5
Outdoor Air	593-OA-01	0.53	<0.22	<0.24	<0.21	<0.21
Indoor Air	593-IA-01	280	--	<0.22	--	--
	593-IA-02	100	--	0.23	0.51	18
	593-IA-03	190	--	0.61	--	--
	593-IA-04	110	--	<0.23	1	18
	593-IA-05	22	--	7.5	--	--
	593-IA-06	13	--	0.49	0.50	1
	593-IA-07	12	--	0.80	0.67	1.2
	593-IA-08	10	--	0.46	--	--
	593-IA-09	13	--	0.39	0.48	1
	593-IA-10	190	10	0.24	1.1	16
	593-IA-10a	--	17	--	--	--
	593-IA-10b	--	260	--	--	--
	593-IA-10c	--	9.2	--	--	--
	593-IA-11	160	11	0.58	--	--
	593-IA-12	230	11	0.56	--	--
	593-IA-13	200	9.6	0.53	6.4	49
	593-IA-14	280	--	0.63	7.4	67
	593-IA-15	220	--	0.49	--	--
	593-IA-16	200	--	0.52	7.2	56
	593-IA-17	600	39	0.65	11	110
	593-IA-18	500	33	0.66	9.2	100
	593-IA-19	830	77	0.67	--	--
	593-IA-20	3.6	--	0.69	1.6	19
	593-IA-21	0.63	--	1.9	--	--
	593-IA-22	23	--	0.27	0.74	5.2
	593-IA-23	18	--	0.33	0.93	4.4
	593-IA-24	4.4	3.1	<0.23	--	--
	593-IA-25	4	3.2	<0.25	--	--
	593-IA-26	4.3	2.9	<0.23	--	--
593-IA-27	4.4	3.1	0.40	--	--	
593-IA-28	4.2	3.1	0.28	--	--	
593-IA-29	4.4	3	<0.22	--	--	

Summary of Results for Tetrachloroethene (PCE) (Continued)

Sample Type	Sample ID	Measured Concentration ($\mu\text{g}/\text{m}^3$)				
		Nov 2017	Mar 2018	Aug. 2018	Feb. 2019	Apr 2019
		E1	E2	E3	E4	E5
Indoor Air	593-IA-30	9.6	--	<0.24	0.52	9
	593-IA-31	14	--	<0.22	0.66	10
	593-IA-32	16	--	<0.22	0.79	7.5
	593-IA-33	23	--	<2.2	--	--
	593-IA-34	39	--	<0.22	0.80	7.4
	593-IA-35	41	--	<0.24	0.78	14
	593-IA-36	39	--	<0.30	0.80	17
	593-IA-37	26	--	1.1	--	----
	593-IA-38	12	--	0.24	--	--
	593-IA-39	18	--	0.28	--	--
Sub-Slab Soil Gas	593-SS-01	76	--	130	--	--
	593-SS-02	220	--	400	290	330
	593-SS-03	53	--	87	--	--
	593-SS-04	460	--	790	460	210
	593-SS-05	20	--	38	--	--
	593-SS-06	1900	--	2,800	2,200	2,100
	593-SS-07	1700	--	1,800	1,200	1,700
	593-SS-08	210	--	510	--	--
	593-SS-09	330	--	560	350	54
	593-SS-10	520	370	990	540	260
	593-SS-10a	--	510	--	--	--
	593-SS-10b	--	1400	--	--	--
	593-SS-10c	--	820	--	--	--
	593-SS-11	240	270	200	--	--
	593-SS-12	260	300	380	--	--
	593-SS-13	1100	1000	1,200	880	1,200
	593-SS-14	420	--	2,900	3,000	4,400
	593-SS-15	520	--	390	--	--
	593-SS-16	570	--	650	320	330
	593-SS-17	830	490	630	690	850
	593-SS-18	940	1000	760	830	1,100
	593-SS-19	1400	1300	1100	--	--
	593-SS-20	2,800	--	2,900	2,100	1,900
	593-SS-21	740	--	--	--	--
	593-SS-22	18,000	--	9,400	7,200	4,200
	593-SS-23	12,000	--	12,000	8,600	9,500
	593-SS-24	870	460	1,000	--	--
	593-SS-25	440	240	360	--	--
	593-SS-26	14	17	26	--	--
593-SS-27	630	360	400	--	--	
593-SS-28	110	34	59	--	--	
593-SS-29	--	130	420	--	--	

Summary of Results for Tetrachloroethene (PCE) (Continued)

Sample Type	Sample ID	Measured Concentration (µg/m3)				
		Nov 2017	Mar 2018	Aug. 2018	Feb. 2019	Apr 2019
		E1	E2	E3	E4	E5
Sub-Slab Soil Gas	593-SS-30	42,000	--	54,000	24,000	30,000
	593-SS-31	7,800	--	3,500	250	620
	593-SS-32	2,800	--	4,500	1,400	3,200
	593-SS-33	580	--	980	--	--
	593-SS-34	4,300	--	6,300	3,300	3,300
	593-SS-35	1,400	--	2,000	1,000	870
	593-SS-36	1,000	--	1,400	980	320
	593-SS-37	650	--	950	--	--
	593-SS-38	280	--	200	--	--
593-SS-39	82	--	81	--	--	

Screening level for indoor air is 82 µg/m³ (RIASL12 and TSRIASL12)
Screening level for soil-gas is 2,700 µg/m³ (RIASL12 and TSRIASL12)

	RIASL12 Exceedance
	TSRIASL12 Exceedance

-- = Sample was not collected at this location.

Summary of Results for Trichloroethene (TCE)

Sample Type	Sample ID	Measured Concentration (µg/m³)					Sample Type	Sample ID	Measured Concentration (µg/m³)					
		Nov	Mar	Aug.	Feb.	Apr.			Nov	Mar	Aug.	Feb.	Apr.	
		2017	2018	2018	2019	2019			2017	2018	2018	2019	2019	
		E1	E2	E3	E4	E5			E1	E2	E3	E4	E5	
Outdoor Air	593-OA-01	<0.09	<0.085	<0.095	0.43	<0.085								
Indoor Air	593-IA-01	<0.19	--	<0.085	--	--	593-SS-01	<2.1	--	<2.05	--	--	--	
	593-IA-02	0.29	--	<0.09	<0.09	0.7	593-SS-02	68	--	120	<41.5	90	--	
	593-IA-03	<0.145	--	0.22	--	--	593-SS-03	<2.25	--	<2	--	--	--	
	593-IA-04	0.41	--	<0.09	<0.085	<0.09	593-SS-04	<4.3	--	14	<3.85	<2.3	--	
	593-IA-05	<0.09	--	<0.09	--	--	593-SS-05	<2.1	--	<2.15	--	--	--	
	593-IA-06	<0.115	--	<0.09	<0.1	<0.095	593-SS-06	130	--	180	140	130	--	
	593-IA-07	0.25	--	<0.085	<0.09	<0.095	593-SS-07	96	--	92	69	82	--	
	593-IA-08	<0.085	--	<0.09	--	--	593-SS-08	9.8	--	13	--	--	--	
	593-IA-09	<0.09	--	<0.085	<0.095	<0.09	593-SS-09	<4.7	--	<2.15	<2.05	<2	--	
	593-IA-10	0.5	<0.1	<0.09	<0.09	0.2	593-SS-10	280	220	110	58	4.1	--	
	593-IA-10a	--	0.21	--	--	--	593-SS-10a	--	65	--	--	--	--	
	593-IA-10b	--	<0.185	--	--	--	593-SS-10b	--	3300	--	--	--	--	
	593-IA-10c	--	<0.095	--	--	--	593-SS-10c	--	1300	--	--	--	--	
	593-IA-11	2.5	0.18	<0.09	--	--	593-SS-11	<2.15	<1.95	<2.1	--	--	--	
	593-IA-12	3.3	0.18	<0.095	--	--	593-SS-12	5.3	33	18	--	--	--	
	593-IA-13	3.1	0.33	<0.09	<0.09	1.1	593-SS-13	210	210	250	180	210	--	
	593-IA-14	3.6	--	<0.09	<0.085	1.3	593-SS-14	<2.3	--	7.6	11	14	--	
	593-IA-15	3.4	--	<0.08	--	--	593-SS-15	31	--	27	--	--	--	
	593-IA-16	3.5	--	<0.085	0.22	1.2	593-SS-16	99	--	100	48	27	--	
	593-IA-17	6.7	0.49	<0.095	0.18	2.6	593-SS-17	510	290	460	400	480	--	
	593-IA-18	5.4	0.42	<0.09	0.23	2.2	593-SS-18	240	230	210	190	240	--	
	593-IA-19	8.2	0.86	<0.09	--	--	593-SS-19	130	120	100	--	--	--	
	593-IA-20	<0.09	--	<0.095	<0.09	0.47	593-SS-20	1100	--	1100	860	650	--	
	593-IA-21	0.8	--	0.2	--	--	593-SS-21	17	--	24	--	--	--	
	593-IA-22	0.29	--	<0.095	<0.085	<0.155	593-SS-22	810	--	620	380	220	--	
	593-IA-23	0.22	--	<0.09	<0.1	<0.095	593-SS-23	280	--	300	180	210	--	
	593-IA-24	<0.09	<0.09	<0.09	--	--	593-SS-24	<2.25	<1.8	5.4	--	--	--	
	593-IA-25	<0.09	<0.425	0.22	--	--	593-SS-25	<6.5	<7	<4.8	--	--	--	
	593-IA-26	<0.09	<0.095	<0.09	--	--	593-SS-26	<2.05	<6.5	<5	--	--	--	
	593-IA-27	<0.095	<0.09	<0.09	--	--	593-SS-27	<3.65	<1.95	<2.2	--	--	--	
	593-IA-28	<0.09	<0.09	<0.09	--	--	593-SS-28	<2.2	<2.05	<2.2	--	--	--	
	593-IA-29	<0.09	<0.085	<0.085	--	--	593-SS-29	---	<2	12	--	--	--	
	593-IA-30	0.93	--	<0.095	<0.09	0.2	593-SS-30	1500	--	2400	230	270	--	
	593-IA-31	0.23	--	<0.09	<0.09	0.44	593-SS-31	66	--	37	<2.15	11	--	
	593-IA-32	0.24	--	<0.09	<0.09	0.41	593-SS-32	110	--	540	940	26	--	
	593-IA-33	<0.095	--	<0.85	--	--	593-SS-33	<2.1	--	24	--	--	--	
	593-IA-34	<0.09	--	<0.085	<0.09	0.19	593-SS-34	160	--	240	110	120	--	
	593-IA-35	0.27	--	<0.095	<0.09	0.2	593-SS-35	<14	--	<11	<7	<3.8	--	
	593-IA-36	0.25	--	<0.12	<0.085	1.6	593-SS-36	11	--	17	12	<2	--	
593-IA-37	0.29	--	<0.09	--	--	593-SS-37	<2.05	--	<2.2	--	--	--		
593-IA-38	0.39	--	<0.085	--	--	593-SS-38	5.5	--	7.7	--	--	--		
593-IA-39	0.36	--	<0.09	--	--	593-SS-39	10	--	11	--	--	--		

Screening level for indoor air are 4 µg/m³ (RIASL12) and 12 µg/m³ (TSRIASL12)
 Screening level for soil-gas is 130 µg/m³ (RIASL12) and 400 µg/m³ (TSRIASL12)

	RIASL12 Exceedance
	TSRIASL12 Exceedance

-- = Sample was not collected at this location.

EVALUATION OF VI DATA TRENDS

Data trends for Building 593 are discussed below for both sub-slab soil gas and indoor air. When data exhibit a narrow range of variability, it is typical practice to express the range as a percentage. When data exhibit a large range of variability, however, it is more useful to express the range in orders of magnitude (i.e., factors of 10). This can be expressed mathematically as the log of the ratio of maximum/minimum values. If the values differ by a factor of 10, the log of the ratio is 1, if the values differ by a factor of 100, the log of the ratio is 2, and so on.

The variability across all locations over all sampling events is the total variability. This encompasses different types of variability, including spatial variability (i.e., how do the results vary from location to location), temporal variability (i.e., how do the results at a given location vary over time), and measurement variability. Measurement variability can be determined by evaluating results of duplicate or collocated samples and includes both sampling variability and analytical variability. The comparison of two data values is typically expressed as a RPD. The comparison of three or more data values is typically expressed as the %CV, which is the standard deviation divided by the mean.

Sub-Slab Soil Gas Data Trends

Spatial Variability of Sub-Slab Soil Gas - The sub-slab soil gas exhibits up to three orders of magnitude of spatial variability. For example, sub-slab detections of PCE vary from 26 to 54,000 $\mu\text{g}/\text{m}^3$ during E3 (log of max./min. = 3.3) across the 39 sample locations at Building 593. During that same sampling event, the range for TCE was 5.4 to 2,400 $\mu\text{g}/\text{m}^3$ (log of max./min. = 2.6). For other sampling events, the log (max./min.) generally was about 2.0-3.1 for PCE and 1.9 to 2.5 for TCE. The spatial variability of TCE appears to be slightly less than PCE, but the evaluation of the data set is limited by the presence of multiple ND values, which may obscure underlying/similar data trends among these two analytes.

Temporal Variability of Sub-Slab Soil Gas - The temporal variability of the sub-slab soil gas data ranged from slightly less than 1 to 1.5 orders of magnitude. The greatest temporal variability for PCE was observed at 593-SS-31 (620 to 7800 $\mu\text{g}/\text{m}^3$, log max/min = 1.49) and 593-SS-09 (54 to 330, log max/min = 1.02). The locations with the highest PCE concentrations (593-SS-30, 593-SS-22, and 593-SS-23) had less temporal variability (log max/min = 0.35, 0.63 and 0.14, respectively).

For TCE, the greatest temporal variability was observed at 593-SS-10 (4.1 to 280 $\mu\text{g}/\text{m}^3$, log max/min = 1.83) and 593-SS-32 (26 to 940 $\mu\text{g}/\text{m}^3$, log max/min = 1.56). The location with the highest TCE concentration that was sampled for four events (593-SS-30) had an order of magnitude of temporal variability (270 to 1500 $\mu\text{g}/\text{m}^3$, log max/min = 1.02). Even less temporal variability was observed at the location with the next batch of highest concentrations (593-SS-20 at 650 to 1100 $\mu\text{g}/\text{m}^3$, log max/min = 0.23).

Seasonal Confirmation Sampling Trend Analysis - PCE data was used for this assessment as PCE was the only sub-slab soil gas analyte with result $>1,000 \mu\text{g}/\text{m}^3$ that was detected in every sub-slab soil gas sample collected at Building 593 (TCE was not detected in every sub-slab soil gas sample). No formal statistical tests were performed but the sub-slab soil gas data at locations with the highest concentrations exhibit some downward trend over the course of E1 and E3-E5 in the figure below. PCE data for locations 593-SS-22, 593-SS-23, 593-SS-30, 593-SS-32, and 593-SS-34 are shown.

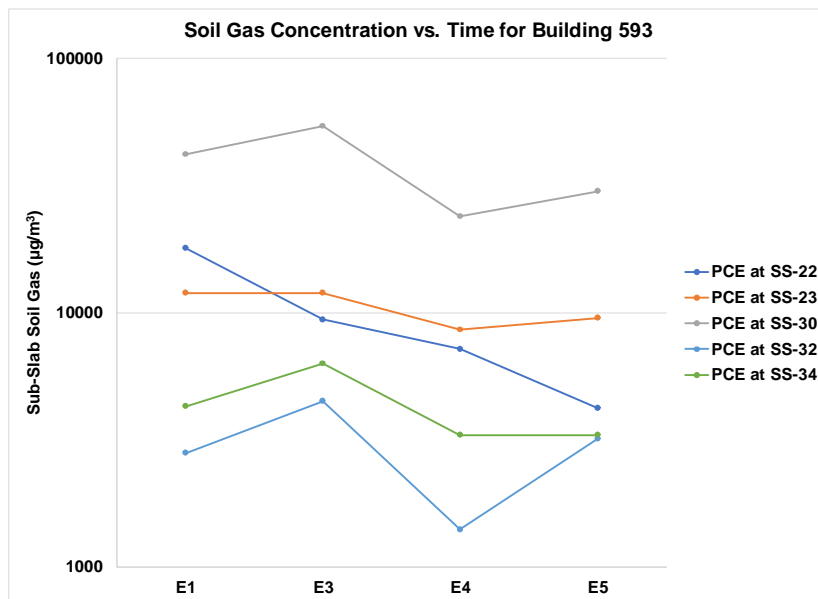

For analytes with lower sub-slab soil gas concentrations, the values tended to be more stable over time. This is illustrated in the figure below. PCE data for locations 593-SS-13, 593-SS-17, and 593-SS-18 are shown. These locations were sampled for all five seasonal confirmation sampling events.

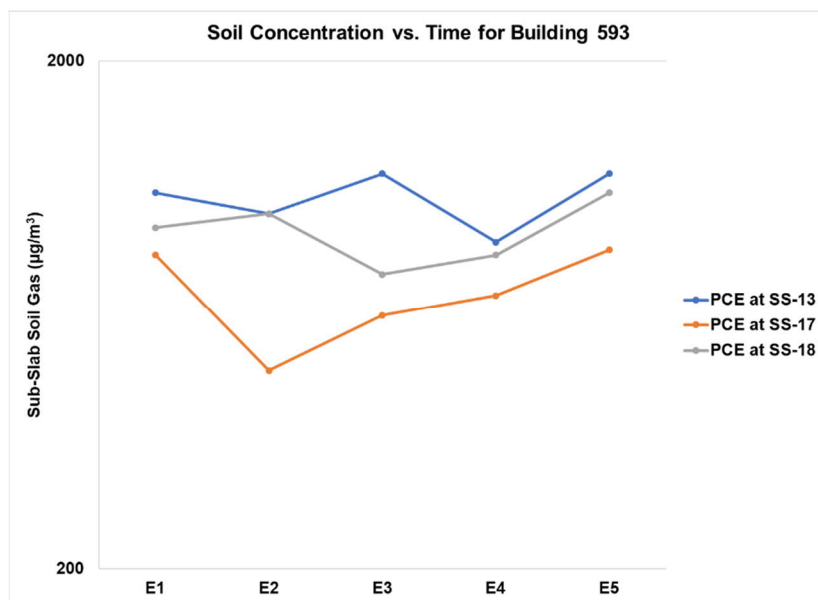

The data set was examined to see what potential consequences would have been had only a single sampling event been performed. The maximum sub-slab soil concentration was obtained during E3 (summer). For PCE at location 593-SS-30, the value increased from 42,000 µg/m³ during E1 to 54,000 during E3. If only the first sampling event had been performed, a negative bias of 28% would have been introduced (i.e., the PCE value for E3 was 28% higher than the PCE value for E1).

Indoor Air Data Trends

Spatial Variability of Indoor Air - The spatial variability of indoor air, ranges from no spatial variability to roughly 3 orders of magnitude. For PCE, the indoor air exhibits roughly 1.5 to 3 orders of magnitude spatial variability. The magnitude of spatial variability for PCE was greatest during E1 (log max/min =

3.1). The spatial variability fell within a similar range for the other sampling events, with E3 and E4 having similar results (log max/min = 1.5 to 1.4, respectively) as did E2 and E5, which both had log max/min = 2.0. TCE indoor air concentrations exhibit less spatial variability than PCE. The highest spatial variability of TCE was observed during E1 (log max/min = 1.6). No spatial variability of TCE was observed during E3, primarily due to it not being detected or only being detected at very low levels. Both TCE and PCE had their maximum observed spatial variability during E1 and their lowest (or second lowest) spatial variability during E3.

Temporal Variability of Indoor Air - The detected values for PCE exhibit a temporal variability of roughly 1.5 orders of magnitude. The greatest temporal variability in PCE (average log max/min = 2.7) was observed at locations sampled in the lunch room, conference room, and men's locker room with its adjoining hallway (locations 593-IA-11 through 593-IA-19). Outside of those areas, the temporal variability was lower. TCE in indoor air exhibited similar trends, only to a lesser degree with an average temporal variability of log max/min = 0.41. Again, the greatest temporal variability in TCE (average log max/min = 0.99) was observed across locations 593-IA-11 through 593-IA-19, and outside those areas the variability drops to roughly a factor of two.

Additional Analyses

Comparison of Sub Slab Soil Gas and Indoor Air Data Sets - As expected, the sub-slab soil gas data exhibit greater spatial variability than the indoor air data set. Indoor air had greater temporal variability than the sub-slab soil gas data, which is consistent with expectations, but there is less difference than has been observed at other buildings. This may be a function of the relatively low sub-slab soil gas concentrations at Building 593.

Seasonal Effects - The highest indoor air concentrations for PCE and TCE were measured in the late fall (E1) and early spring (E2 and E5). The highest sub-slab concentrations for PCE and TCE were measured in E3 (August) and E2 (March), respectively, with the highest results for PCE observed during summer. The data do not support the hypothesis that wintertime will have higher indoor air impacts.

Comparison of Attenuation Factors by Event - Attenuation factors were calculated based on maximum values and are shown in the table below. The values have not been corrected for any contribution from outdoor air.

Calculated Attenuation Factors

Analyte	Sampling Event				
	E1	E2	E3	E4	E5
PCE	4.6E-02	NC	1.4E-04	4.6E-04	3.7E-03
TCE	5.5E-03	2.6E-04	9.2E-05	2.5E-04	4.0E-03
1,1,1-TCA	<5.9E-5	9.2E-05	<7.1E-06	<1.1E-05	2.4E-05

The tabulated attenuation factors generally are consistent except that TCE tends to show greater attenuation, which is consistent with indoor emission sources of PCE during certain sampling events (e.g., E1). No attenuation factor for PCE is shown for E2 given that the locations with higher PCE impacts were not sampled during that event. The most defensible, conservative estimates of a building specific attenuation factor for Building 593 are assumed to be values for PCE and TCE for events E2 through E4. The most conservative of these is 1.4E-04 for PCE during E3. The data for 1,1,1-TCA are the least affected by indoor emission sources and the calculated attenuation factors for 1,1,1-TCA suggest that the building-specific attenuation factor selected is a conservative choice.

Temporal Variability in Attenuation Factor - As shown in the table above, there was more than one order of magnitude in temporal variability in the calculated attenuation factors observed in the data set, with E1 and E5 have the lower attenuation factors for both analytes when compared to E3 and E4, respectively (as E1/E3 and E4/E5 were sampled using the same number of sampling locations). The attenuation factors for PCE and TCE are three orders of magnitude different from each other for the

limited sampling event (E2), which likely is caused by the adjustment made to the sampling location matrix toward locations with observed indoor air exceedances of PCE. The figure below plots the inverse attenuation factor for these three analytes for each sampling event, taller columns denote greater attenuation (i.e., less VI). Assuming VI was the only source of analytes in indoor air, all of the columns would be expected to have about the same height. Shorter columns represent greater contribution for indoor or outdoor sources for a given analyte.

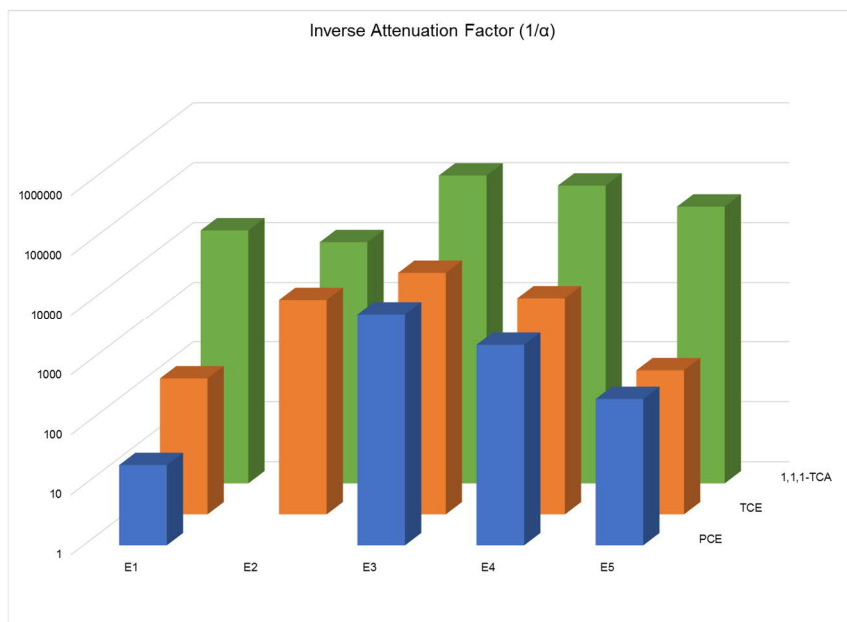

NON-DETECT EVALUATION

Table 593-6 below lists the analytes in sub-slab soil gas that have ND RLs greater than the screening levels. If a sub-slab soil gas analyte has ND RL exceedances, but all results and ND RLs in indoor air are below the screening levels, no further evaluation is warranted.

If an analyte was identified as an AOI in sub-slab soil gas (detected results > screening level), it is excluded from the ND evaluation; therefore, naphthalene will not be included in the ND evaluation. Also, if an ND analyte has a 0% detection frequency for all sampling events and all ND RLs met the screening level during at least one event, no further ND evaluation is warranted.

Table 593-6. Non-Detect Evaluation for Building 593

Soil Gas Analytes with ND RL > SL	Indoor Air Result Summary
1,1,2,2-Tetrachloroethane	0% Detection Frequency, 99% ND RLs < RIASL ₁₂
1,1,2-Trichloroethane	0-4% Detection Frequency, 100% detections and >96% ND RLs < RIASL ₁₂
Alpha-Chlorotoluene	0% Detection Frequency, >95% ND RLs < RIASL ₁₂
Dibromomethane	0% Detection Frequency, >95% ND RLs < RIASL ₁₂
Hexachlorobutadiene (HCBd)	0% Detection Frequency, 100% ND RLs > RIASL ₁₂
1,2,4-Trichlorobenzene	0% Detection Frequency, >50% ND RLs > RIASL ₁₂
1,2-Dibromoethane (EDB)	0% Detection Frequency, >99% ND RLs > RIASL ₁₂
Naphthalene	0%-6% Detection Frequency, 99% detects and NDs < RIASL ₁₂

WEIGHT OF EVIDENCE SUMMARY

Building 593 was confirmed as a VI Path Forward Group 4A building due to its potential for VI based on sub-slab soil gas exceedances of the draft project-specific RIASL₁₂ and/or TSRIASL₁₂. However, after

further investigation and evaluation, the following evidence supports the conclusion that VI is insignificant at Building 593:

- The sub-slab soil gas results indicate that concentrations are stable or decreasing.
- Indoor air results have been inconsistent and indicate workplace chemical use. Indoor sources were identified during the building survey completed in the late summer of 2017 and the further investigation completed in October 2019.
- The data do not support the hypothesis that wintertime should have the highest indoor air impacts. The sub-slab soil gas concentrations are no higher in winter than during other seasons, with the highest PCE results occurring in the summer. The highest indoor air concentrations were measured in the spring and fall.
- Although the further investigation completed in October 2019 has potentially identified a preferential pathway, all results from that event were below the applicable RIASL₁₂/TSRIASL₁₂ values for PCE, TCE and chloroform.
- As shown in the table below, the building-specific attenuation factor yields estimated indoor air concentrations for the three ND analytes identified above that are well below the screening levels. The selected building-specific attenuation factor was used to estimate an indoor air concentration for the highest ND sub-slab soil gas result for the respective analyte. The results indicate that no further evaluation is needed for these three ND analytes.

Parameters	EDB	HCBD	1,2,4-Trichlorobenzene
Building Specific Attenuation Factor	1.39 E-04		
Maximum ND Reporting Limit in SSSG	<60	<340	<240
Estimated Indoor Air Concentration	<0.008	<0.05	<0.03
Indoor Air RIASL ₁₂	0.2	5.4	6.2

Based on the CSM for Building 593, VI is an insignificant exposure pathway for current building utilization.

SUMMARY AND PATH FORWARD

Based on the evaluation of the seasonal confirmation sampling events and the results of the further investigation, the VI pathway continues to be insignificant for Building 593. Weight of evidence based on seasonal confirmation sampling, as documented in email notifications provided to EGLE throughout 2018 and 2019, supports Building 593 as a Group 4A building, which is defined as: Building seasonal confirmation sample results demonstrate a lack of correlated sub-slab soil gas and indoor air exceedances (RIASL¹² and/or TSRIASL¹²) and other lines of evidence indicate VI is insignificant and IA exceedances are likely due to work place chemical use. The sub-slab soil gas results have demonstrated relatively stable concentrations and no evidence of increasing over time. Furthermore, follow-up activities will occur in the area of the potential preferential pathway near (593-xx-14) in early 2020 and results will be communicated with EGLE.

Sufficient information exists to make a human exposure under control EI determination. However, while currently there is no evidence of potential VI, for future use, LTM is warranted and the building-specific Interim Monitoring Plan is discussed below.

Building-specific Interim Monitoring Plan

Dow presented an interim monitoring plan for Building 593 during the July 2019 Corrective Action status meeting. Dow will implement the interim monitoring plan at Building 593 until a revised program or more permanent corrective action plan is developed for the site.

Indoor air is being monitored at locations 593-IA-20, -22, -29, and -30. These locations were selected for continued monitoring since they demonstrated the highest sub-slab soil gas results. Monitoring will be performed for 1,1,2-TCA, 1,2-DCP, chloroform, HCB, PCE, and TCE. An outdoor air sample is also collected at the time of each monitoring event. Monitoring began in December 2019 and will be performed semi-annually for a minimum of two years and monitoring results will undergo trend analysis. If results continue to be consistent and below screening levels, monitoring will be conducted on an annual basis. If indoor air results are observed to be increasing, further evaluation will be performed, which may include collection of a sub-slab soil gas sample(s) and an increase in monitoring frequency. Results from each monitoring event will be reported in the annual CAIP. In the event an indoor air result(s) exceeds screening levels, EGLE will be provided a brief email notification. A collocated indoor air and sub-slab soil gas sample will be collected from that location within 45 days. If both sub-slab soil gas and indoor air results indicate that VI continues to be insignificant, monitoring will continue at an appropriate frequency. If both sub-slab soil gas and indoor air results indicate that VI is significant, the building will be moved to Group 4B for follow-up actions.

Dow may propose changes to the frequency or other aspects of this interim monitoring plan in the future based on an evaluation of the data, changes in building use or implementation of other corrective actions to address the potential VI pathway.

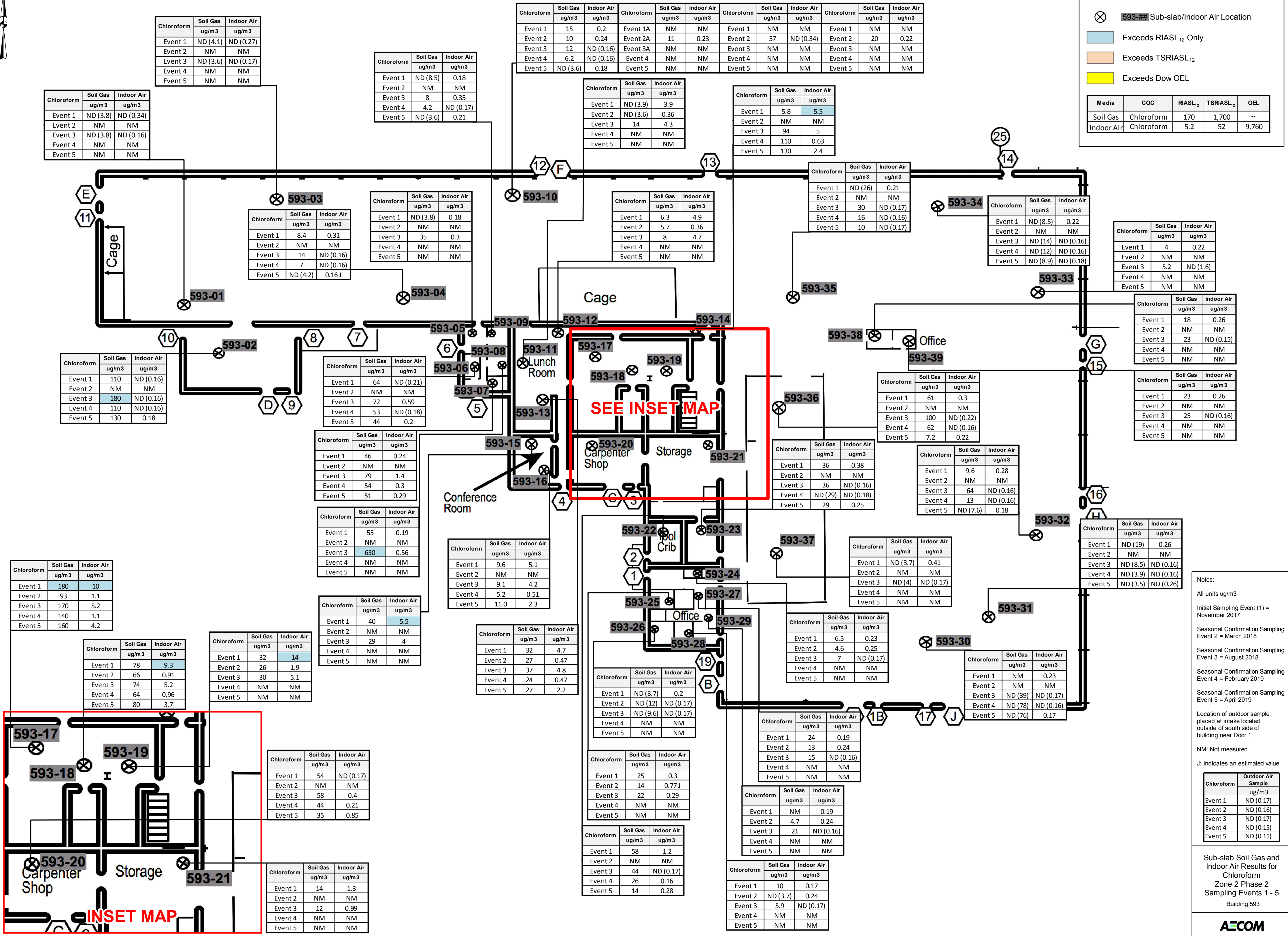

Figure 593-1

Legend

- ⊗ 593-### Sub-slab/Indoor Air Location
- Exceeds RIASL₁₂ Only
- Exceeds TSRIASL₁₂
- Exceeds Dow OEL

Media	COC	RIASL ₁₂	TSRIASL ₁₂	OEL
Soil Gas	Chloroform	170	1,700	--
Indoor Air	Chloroform	5.2	52	9,760



Notes:

All units ug/m3

Initial Sampling Event (1) = November 2017

Seasonal Confirmation Sampling Event 2 = March 2018

Seasonal Confirmation Sampling Event 3 = August 2018

Seasonal Confirmation Sampling Event 4 = February 2019

Seasonal Confirmation Sampling Event 5 = April 2019

Location of outdoor sample placed at intake located outside of south side of building near Door 1.

NM: Not measured

J: Indicates an estimated value

Chloroform ug/m3	Outdoor Air Sample ug/m3
Event 1	ND (0.17)
Event 2	ND (0.16)
Event 3	ND (0.17)
Event 4	ND (0.15)
Event 5	ND (0.15)

Sub-slab Soil Gas and Indoor Air Results for Chloroform Zone 2 Phase 2 Sampling Events 1 - 5 Building 593

AECOM

Figure 593-2

Legend

- ⊗ 593-### Sub-slab/Indoor Air Location
- Orange box Exceeds TSRIASL₁₂
- Yellow box Exceeds Dow OEL

Media	COC	RIASL ₁₂	TSRIASL ₁₂	OEL
Soil Gas	PCE	2,700	2,700	--
Indoor Air	PCE	82	82	67,800

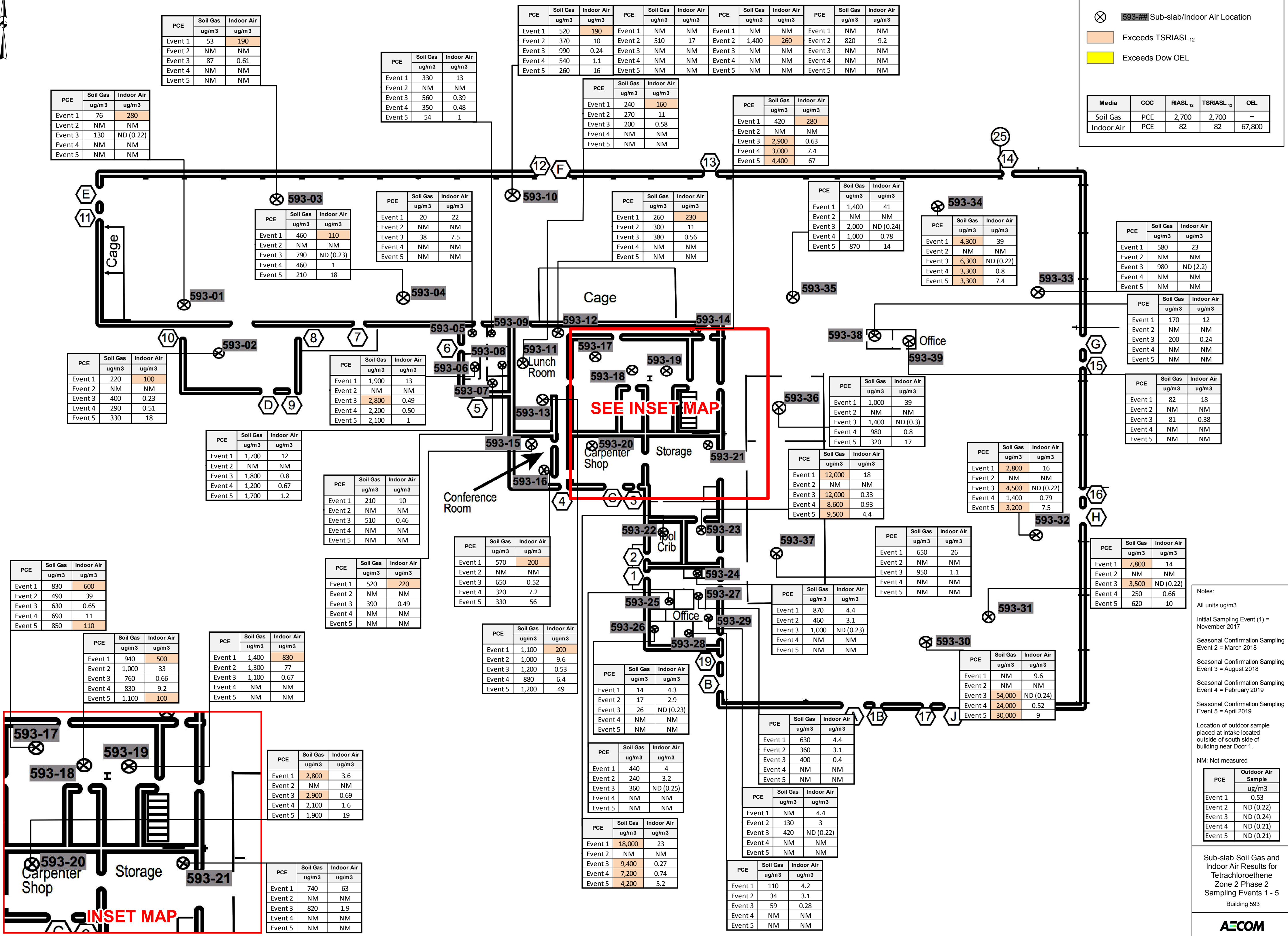

Notes:

- All units ug/m³
- Initial Sampling Event (1) = November 2017
- Seasonal Confirmation Sampling Event 2 = March 2018
- Seasonal Confirmation Sampling Event 3 = August 2018
- Seasonal Confirmation Sampling Event 4 = February 2019
- Seasonal Confirmation Sampling Event 5 = April 2019
- Location of outdoor sample placed at intake located outside of south side of building near Door 1.
- NM: Not measured

PCE	Outdoor Air Sample
ug/m ³	ug/m ³
Event 1	0.53
Event 2	ND (0.22)
Event 3	ND (0.24)
Event 4	ND (0.21)
Event 5	ND (0.21)

Sub-slab Soil Gas and Indoor Air Results for Tetrachloroethene Zone 2 Phase 2 Sampling Events 1 - 5 Building 593

AECOM

Figure 593-3

Legend

- ⊗ 593-### Sub-slab/Indoor Air Location
- Exceeds RIASL₁₂ Only
- Exceeds TSRIASL₁₂
- Exceeds Dow OEL

Media	COC	RIASL ₁₂	TSRIASL ₁₂	OEL
Soil Gas	TCE	130	400	--
Indoor Air	TCE	4	12	26,850

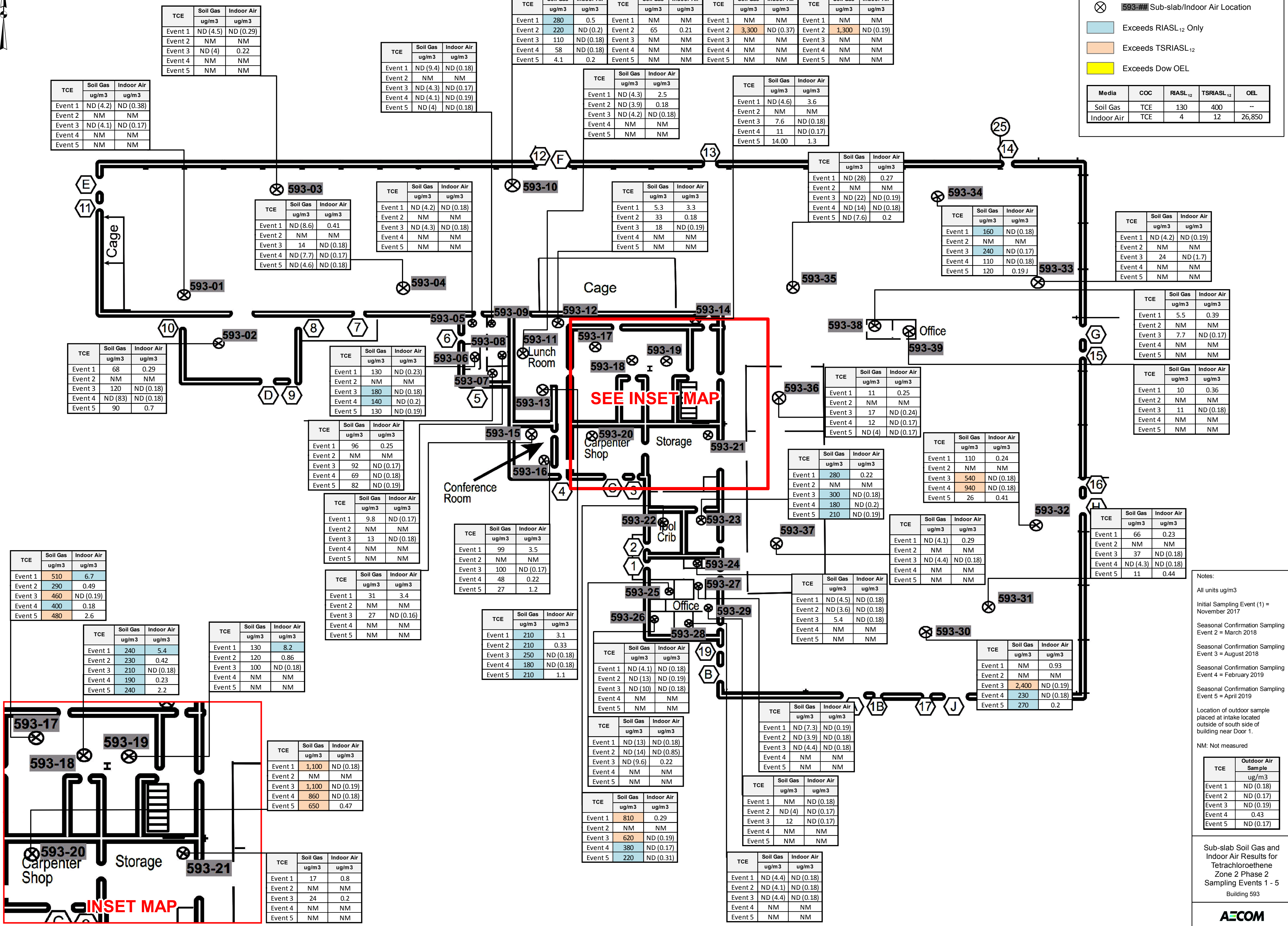

Notes:

- All units ug/m3
- Initial Sampling Event (1) = November 2017
- Seasonal Confirmation Sampling Event 2 = March 2018
- Seasonal Confirmation Sampling Event 3 = August 2018
- Seasonal Confirmation Sampling Event 4 = February 2019
- Seasonal Confirmation Sampling Event 5 = April 2019
- Location of outdoor sample placed at intake located outside of south side of building near Door 1.
- NM: Not measured

TCE	Outdoor Air Sample
Event 1	ND (0.18)
Event 2	ND (0.17)
Event 3	ND (0.19)
Event 4	0.43
Event 5	ND (0.17)

Sub-slab Soil Gas and Indoor Air Results for Tetrachloroethene Zone 2 Phase 2 Sampling Events 1 - 5 Building 593

AECOM

5.4.5 VI Seasonal Confirmation Sampling Results Evaluation for Building 826/494

INTRODUCTION

Building 826/494 is a Category 2 building in Zone 2. It is located in the southeastern quadrant of the Midland facility and is known as the Maintenance Shops (Figure 5.4.5-1). The initial evaluation in the 2018 CAIP concluded that based on the indoor air results, the VI pathway at Building 826/494 is an insignificant exposure pathway based on current use. No indoor air analytes were detected above screening levels at Building 826/494; however, based on sub-slab soil gas results greater than screening levels for CFC-12, PCE, and TCE. Building 826/494 was placed into VI Path Forward Building Group 2 and seasonal confirmation sampling was conducted. Building 826/494 has undergone four seasonal confirmation sampling events:

Building 826/494	
Initial Sampling Event	Completed
E1	October/November 2017 (Fall)
Seasonal Sampling Event	Completed
E2	March 2018 (Spring)
E3	August 2018 (Summer)
E4	February 2019 (Winter 2019)

Based on the evaluation of the four seasonal confirmation sampling events, the VI pathway continues to be insignificant. Sufficient information exists to make a human exposure under control EI determination.

SUB-SLAB SOIL GAS RESULTS EVALUATION

Sub-slab soil gas samples were collected from six locations from within the building. Indoor air samples were collected at six locations corresponding to the soil gas sample locations, along with an outdoor air sample from the main air intake. The sampling locations are shown on Figure 5.4.5-2. Summary statistics and screening comparison results are presented for sub-slab soil gas on Table 5.4.5-A and indoor and outdoor air on Table 5.4.5-B. The analytical data is presented in Appendix A. Field sampling forms are provided in Appendix B. Table 826/494-1 presents the sub-slab soil gas results that exceed the draft project-specific screening levels.

Table 826/494-1. Summary of Sub-Slab Soil Gas Exceedances for Building 826/494

Analyte (Sampling Event)	Detection Frequency	Measured Range of Detects ($\mu\text{g}/\text{m}^3$)	% Detections > Screening Level	Screening Level* ($\mu\text{g}/\text{m}^3$)
CFC-12 (1)	100%	520 - 280,000	50%	34,000
CFC-12 (2)	100%	160 - 520,000	50%	34,000
CFC-12 (3)	100%	410 - 70,000	33%	34,000
CFC-12 (4)	83%	350 - 34,000	0%	34,000
Tetrachloroethene (1)	100%	5,400 - 29,000	100%	2,700
Tetrachloroethene (2)	83%	3,900 - 36,000	83%	2,700
Tetrachloroethene (3)	100%	5,300 - 36,000	100%	2,700
Tetrachloroethene (4)	100%	380 - 37,000	67%	2,700
Trichloroethene (1)	83%	310 - 3,200	83%	130
Trichloroethene (2)	83%	200 - 5,100	83%	130
Trichloroethene (3)	100%	260 - 4,400	100%	130
Trichloroethene (4)	100%	7.8 - 4,200	83%	130

*Screening level provided is the draft project-specific RIASL₁₂.

Table 826/494-2 summarizes the indoor air results relative to the sub-slab soil gas exceedances, since VI only potentially occurs if the analyte is present in both sub-slab soil gas and indoor air. Therefore, the

table below provides the analyte detected above applicable screening levels in sub-slab soil gas as well as the corresponding indoor air sample result. The outdoor air sample result is also provided to determine if the analytes were present in indoor air due to migration from outdoor air.

Table 826/494-2. Vapor Intrusion Evaluation for Building 826/494

Analyte (Sampling Event)	Indoor Air Detection Frequency	Indoor Air Measured Range ($\mu\text{g}/\text{m}^3$)	Indoor Air Screening Level* ($\mu\text{g}/\text{m}^3$)	Outdoor Air Result ($\mu\text{g}/\text{m}^3$)
CFC-12 (1)	100%	2.1 - 3.7	1,020	2
CFC-12 (2)	100%	3 - 4.1	1,020	2.4
CFC-12 (3)	100%	2.3 - 4.8	1,020	2.4
CFC-12 (4)	100%	2.5 - 12	1,020	2.5
Tetrachloroethene (1)	67%	0.47 - 1.6	82	0.96
Tetrachloroethene (2)	100%	0.81 - 1.3	82	1.8
Tetrachloroethene (3)	83%	0.27 - 1.9	82	ND
Tetrachloroethene (4)	100%	1.1 - 3.3	82	0.84
Trichloroethene (1)	17%	0.22	4	ND
Trichloroethene (2)	83%	0.29 - 0.39	4	0.23
Trichloroethene (3)	100%	0.25 - 2.6	4	0.34
Trichloroethene (4)	33%	0.24 - 0.34	4	ND

*Screening level provided is the draft project-specific RIASL₁₂.

All indoor air results for Building 826/494 are below screening levels.

VAPOR INTRUSION CONCEPTUAL SITE MODEL

VI is an exposure pathway that results from the migration of volatilized chemicals from the subsurface to indoor air in overlying occupied buildings. A source, migration route and a human receptor must be present for the VI pathway to be complete. The focus of this building specific investigation is to evaluate the potential VI exposure pathway for employees and contractors at Building 826/494. The CSM is illustrated in Figure 5.4.5-3.

The northern portion of this building, which was constructed sometime between 1938 and 1952, is labeled "494" and is predominantly a storage warehouse with some work benches located in its western half. Along the southern wall is a wall opening/enclosed pathway that connects Building 494 to Building 826. Building 826 is a brick-façade structure that was built between 1965 and 1982 and consists of office space, a shop, a locker room, and kitchen. Both portions of the combined 7,914 ft² single-story building are slab-on-grade with no basement or elevator. Although the buildings are considered one structure, different areas within the structure will be defined as being in "Building 826" or "Building 494" for clarity. The ground cover outside the combined building is predominantly asphalt.

The combined structure is predominantly used by operations controlled by Building 1130 and contractors that support Building 1130 operations. It is typically used on an intermittent/as needed basis. If the building is being used/occupied, an occupant would likely be working an 8-hour shift. There is a washer/dryer setup located in the Building 826 locker room. The shop portion of Building 826 can allow a car to pull into the shop bay. Gas-powered equipment and gasoline/fuels are stored in the Building 826 shop area.

The combined building is predominantly heated via hot air circulation. There are electric baseboards present in some of the Building 826 offices, and the Building 826 shop area has some ceiling-mounted heating units. The eastern portion of Building 826 is cooled via central AC; however, some individual AC units were observed for the office spaces located to the northwest of the Building 826 shop area, the office space on the south side of the building, and also for the Building 826 kitchen. The combined

structure has three bay doors, two of the doors are located on the eastern and western sides of the Building 494, and the third bay door is located on the western side of the Building 826 shop.

Building occupancy is intermittent based on need since Building 826/494 is a contractor space in support of the process area in Building 1130. Potentially at any given time there may be 5 to 10 occupants. Shifts are sporadic but tend to be 8 hours per day when contractors are present. Until building use changes to a more permanent usage, the typical parameters for non-residential exposures are assumed to apply but likely overestimate exposure for the personnel stationed at this building (i.e., 40 hours/week, 50 weeks/year exposure).

A building survey was completed before the initial sampling event. Drains and other openings were screened with a PID and no soil gas entry points were identified. Minor PID readings (0.1-0.3 ppm) were observed in the ambient air measured in Building 826 locker room, the southeastern conference room, the northwestern conference room, the small bathroom in the northeastern corner, in the east-west hallway leading to the locker room, and in the drain in the small bathroom found in northeastern corner of Building 826. A chemical inventory was completed during the building survey that identified cleaners, degreasers, spray paint and penetrating catalysts.

EVALUATION OF SEASONAL CONFIRMATION SAMPLING EVENTS

Four seasonal sampling events and one interim monitoring event have been completed at Building 826/494. The sampling events encompass more than one year of time and include sampling during each season of the year. The results from the four seasonal confirmation sampling events were evaluated with respect to spatial variability, temporal variability, and seasonal trend analysis.

Building specific attenuation factors (α) were calculated and compared between events to evaluate temporal variability and determine the best estimate of a building-specific attenuation factor. This evaluation serves to confirm that the existing study design is appropriate, and also provides insight for the determination of the path forward for this building.

This evaluation focused on any analytes detected in the sub-slab soil gas samples that met the criterion for inclusion in one or more of the following categories:

- a) Analytes detected in sub-slab soil-gas at concentrations that exceeded draft project-specific screening levels;
- b) Analytes detected in sub-slab soil-gas at concentrations of 1,000 $\mu\text{g}/\text{m}^3$ or greater in one or more samples. Data for analytes detected above 1,000 $\mu\text{g}/\text{m}^3$ should provide the clearest signal and be the simplest to interpret when assessing data trends. The same data trends observed for these analytes are expected to apply to other similar analytes present at lower concentrations; and
- c) PCE and TCE. These two analytes are of particular interest for many VI evaluations at industrial sites.

For this building, the only analytes detected in the sub-slab soil gas at concentrations above the draft project-specific screening levels were CFC-12, PCE, and TCE. One additional analyte had a detected concentration $\geq 1,000 \mu\text{g}/\text{m}^3$, 2,2,4-trimethylpentane; however, since there was the only detection of 2,2,4-trimethylpentane and it was excluded from additional evaluation. Sample results for these analytes are provided in the following data tables below:

Summary of Results for Chlorofluorocarbon (CFC-12)

Sample Type	Sample ID	Measured Concentration (µg/m ³)			
		Oct./Nov. 2017	Mar. 2018	Aug. 2018	Feb. 2019
		E1	E2	E3	E4
Outdoor Air	826/494-OA-01	2	2.4	2.4	2.5
Indoor Air	826/494-IA-01	3.3	4	4.7	8.5
	826/494-IA-02	3.7	4	4.8	8
	826/494-IA-03	2.1	3	2.3	2.5
	826/494-IA-04	2.8	3.6	3.9	12
	826/494-IA-05	2.7	3.1	3.9	2.6
	826/494-IA-06	3.4	4.1	4.5	8.9
Sub-Slab Soil Gas	826/494-SS-01	19,000	39,000	70,000	<4
	826/494-SS-02	40,000	36,000	34,000	34,000
	826/494-SS-03	520	160	410	<4
	826/494-SS-04	32,000	6,400	30,000	30,000
	826/494-SS-05	280,000	520,000	6,000	350
	826/494-SS-06	44,000	16,000	50,000	29,000

Screening levels for indoor air are 1,020 µg/m³ (RIASL₁₂)

Screening levels for soil-gas are 34,000 µg/m³ (RIASL₁₂)

Summary of Results for Tetrachloroethene (PCE)

Sample Type	Sample ID	Measured Concentration (µg/m ³)			
		Oct./Nov. 2017	Mar. 2018	Aug. 2018	Feb. 2019
		E1	E2	E3	E4
Outdoor Air	826/494-OA-01	0.96	1.8	<0.23	0.84
Indoor Air	826/494-IA-01	0.47	1.2	0.73	3.1
	826/494-IA-02	1.6	1.3	1.9	3.1
	826/494-IA-03	<0.22	0.86	<0.22	1.2
	826/494-IA-04	0.56	1.2	0.70	3.3
	826/494-IA-05	<0.23	0.81	0.27	1.1
	826/494-IA-06	0.52	1.1	0.70	3
Sub-Slab Soil Gas	826/494-SS-01	13,000	36,000	36,000	24,000
	826/494-SS-02	26,000	36,000	27,000	37,000
	826/494-SS-03	6,400	3,900	6,100	380
	826/494-SS-04	23,000	7,600	20,000	20,000
	826/494-SS-05	5,400	<5,200	5,300	2,600
	826/494-SS-06	29,000	22,000	32,000	27,000

Screening levels for indoor air are 82 µg/m³ (RIASL₁₂ and TSRIASL₁₂)

Screening levels for soil-gas are 2,700 µg/m³ (RIASL₁₂ and TSRIASL₁₂)

	RIASL12 Exceedance
	TSRIASL12 Exceedance

Summary of Results for Trichloroethene (TCE)

Sample Type	Sample ID	Measured Concentration ($\mu\text{g}/\text{m}^3$)			
		Oct./Nov. 2017	Mar. 2018	Aug. 2018	Feb. 2019
		E1	E2	E3	E4
Outdoor Air	826/494-OA-01	<0.17	0.23	0.34	<0.18
Indoor Air	826/494-IA-01	<0.18	0.29	1.6	<0.19
	826/494-IA-02	0.22	0.32	1.6	<0.35
	826/494-IA-03	<0.17	0.36	0.25	0.24
	826/494-IA-04	<0.18	0.33	2.2	<0.20
	826/494-IA-05	<0.18	<0.18	2.6	0.34
	826/494-IA-06	<0.19	0.39	1.4	<0.19
Sub-Slab Soil Gas	826/494-SS-01	1,700	5,100	4,400	2,800
	826/494-SS-02	2,700	4,000	2,600	4,200
	826/494-SS-03	310	200	260	7.8
	826/494-SS-04	1,800	510	1,600	1,600
	826/494-SS-05	<2,400	<4,100	720	250
	826/494-SS-06	3,200	2,300	3,600	3,100

Screening levels for indoor air are $4 \mu\text{g}/\text{m}^3$ (RIASL₁₂) and $12 \mu\text{g}/\text{m}^3$ (TSRIASL₁₂)
Screening levels for soil-gas are $130 \mu\text{g}/\text{m}^3$ (RIASL₁₂) and $400 \mu\text{g}/\text{m}^3$ (TSRIASL₁₂)

	RIASL12 Exceedance
	TSRIASL12 Exceedance

EVALUATION OF VI DATA TRENDS

Data trends for Building 826/494 are discussed below for both sub-slab soil gas and indoor air. When data exhibit a narrow range of variability, it is typical practice to express the range as a percentage (e.g., relative percent difference [RPD]). When data exhibit a large range of variability, however, it is more useful to express the range in orders of magnitude (i.e., factors of 10). This can be expressed mathematically as the log of the ratio of maximum/minimum values. If the values differ by a factor of 10, the log of the ratio is 1, if the values differ by a factor of 100, the log of the ratio is 2, and so on.

The variability across all locations over all sampling events is the total variability. This encompasses different types of variability, including spatial variability (i.e., how do the results vary from location to location), temporal variability (i.e., how do the results at a given location vary over time), and measurement variability. Measurement variability can be determined by evaluating results of duplicate or collocated samples and includes both sampling variability and analytical variability.

Sub-Slab Soil Gas Data Trends

Spatial Variability of Sub-Slab Soil Gas – The soil gas exhibit up to three orders of magnitude of spatial variability. For example, sub-slab soil gas detections of PCE vary from 5,400 to 29,000 $\mu\text{g}/\text{m}^3$ (log of max./min. = 0.73) across all six locations for E1. Sub-slab soil gas detections of TCE range from 200 to 5,100 $\mu\text{g}/\text{m}^3$ (log of max./min. = 1.4), respectively, across all six locations for E2. Detected concentrations of CFC-12 in sub-slab soil gas vary from 160 to 520,000 $\mu\text{g}/\text{m}^3$ (log max./min. = 3.5) across all six location for E2. Based on this data, there is a relatively modest amount of spatial variability in sub-slab soil gas given the size of the building and the number of sampling locations, with the exception of the CFC-12 data.

Temporal Variability of Soil Gas – The soil gas concentrations exhibit, at most, slightly more than one order of magnitude of temporal variability. For PCE, sub-slab soil gas variability ranges from a log max/min = 0.16 at 826/494-SS-06 to a log max/min = 1.2 at 826/494-SS03. An example of the mid-range of PCE variability can be observed at 826-494-SS-01, which had results varying from 13,000 to 36,000 $\mu\text{g}/\text{m}^3$ (log max/min = 0.44). The results for other sample locations are similar for PCE. Similar

observations are made with the TCE data, for example, sub-slab soil gas concentrations of vary from 1,700 to 5,100 $\mu\text{g}/\text{m}^3$ at location 826/494-SS-01 (log max/min = 0.48).

Sub-slab soil gas concentrations of CFC-12 vary from 34,000 to 40,000 $\mu\text{g}/\text{m}^3$ at location 826.494-SS-02 (log max/min = 0.07) and from 16,000 to 50,000 $\mu\text{g}/\text{m}^3$ at location 826/494-SS-06 (log max/min = 0.5); however, sample location 826/494-SS-05 exhibits more variation with detections ranging from 350 to 520,000 $\mu\text{g}/\text{m}^3$ (log max./min. = 3.2). Based on this evaluation, there is a relatively low amount of temporal variability in sub-slab soil gas which is in-line with expectations with the exception of CFC-12 at 826/494-SS-05. Overall, as expected, the amount of temporal variability is less than the amount of spatial variability.

Seasonal Confirmation Sampling Trend Analysis – No formal statistical tests were performed, but the data exhibits relatively consistent results between the seasons, with the exception of sample location 826/494-SS-05 for CFC-12. This is demonstrated by the graph below, which shows the three analytes selected above at locations where they were detected at relatively high concentrations. Note that the y-axis is a log scale.

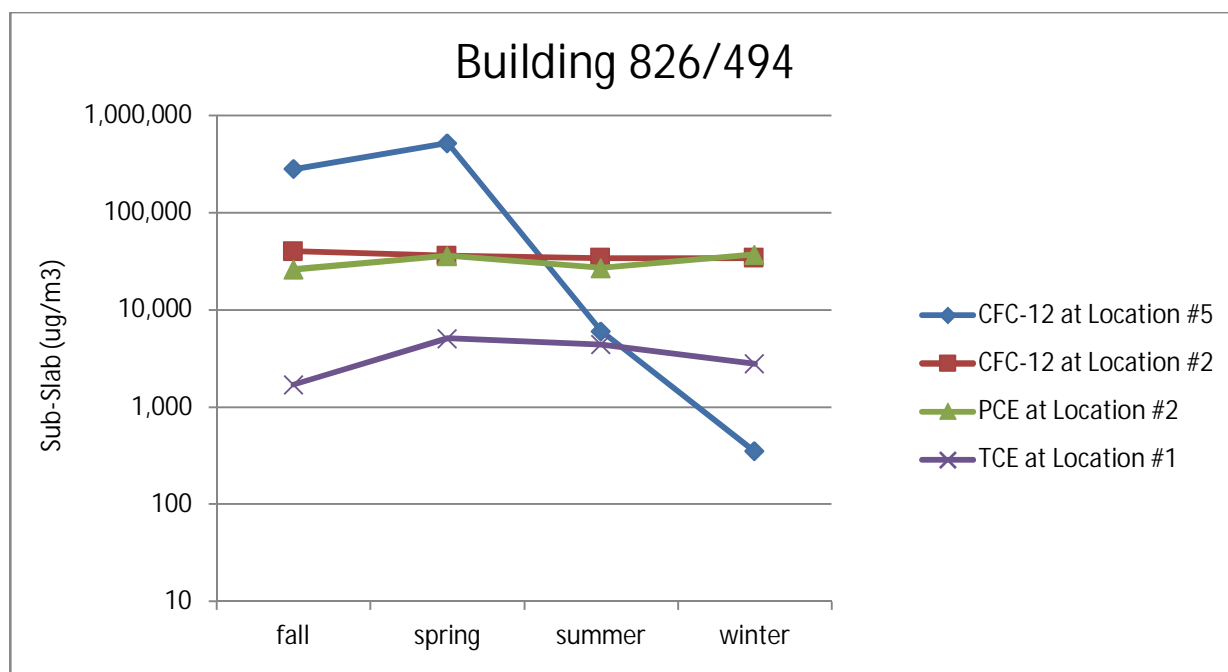

The data set was examined to see what the potential consequences would have been had only a single sampling event been performed. Overall for CFC-12 and TCE, the highest sub-slab soil gas concentrations were collected during the spring (E2) and the lowest concentrations occurred during the winter (E4) and fall (E1), respectively. For PCE, the highest sub-slab concentration was collected during the winter (E4) and the lowest concentration occurred during the fall (E1). Overall, with the exception of CFC-12 at sample location 826/494-SS-05, the minimum and maximum values appear to be consistent between sampling events.

For CFC-12 at location 826/494-SS-05, a concentration of 280,000 $\mu\text{g}/\text{m}^3$ was measured during E1 and the highest concentration (520,000 $\mu\text{g}/\text{m}^3$) was measured during E2. If only E1 had been performed, a negative bias of 86% would have been introduced (i.e., the E2 result was 86% higher than the E1 result). However, for CFC-12 at location 826/494-SS-02, a concentration of 40,000 $\mu\text{g}/\text{m}^3$ was measured during E1 which was the highest concentration. For PCE, the concentration of 26,000 $\mu\text{g}/\text{m}^3$ was measured during E1 and the highest concentration (37,000 $\mu\text{g}/\text{m}^3$) was measured during E4. If only E1 had been performed, a negative bias of 42% would have been introduced. Therefore, with the exception of CFC-

12, implementing four seasonal confirmation sampling events provided only limited insight regarding maximum concentration levels, but the larger data set served to increase the confidence in the findings including demonstrating the consistency of the maximum reported results.

Indoor Air Data Trends

Spatial Variability of Indoor Air – The indoor air exhibits approximately one order of magnitude of spatial variability. CFC-12 had 100% detection frequency in indoor air across all sampling events. During E4, indoor air concentrations vary from 2.5 to 12 $\mu\text{g}/\text{m}^3$ (log max./min. = 0.68). The other events saw less variability. For PCE, the highest spatial variability occurred during E3 where indoor air concentrations vary from 0.27 to 1.9 $\mu\text{g}/\text{m}^3$ (log max./min. = 0.85). The highest spatial variability occurred for TCE in E3 when concentrations ranged from 0.25 to 2.6 $\mu\text{g}/\text{m}^3$ (log max./min. = 1.0). The PCE, CFC-12, and TCE data suggests the air within the building is well-mixed and influenced by outdoor air, since the concentrations of indoor and outdoor air are similar or roughly equivalent, especially for CFC-12 and PCE.

Temporal Variability of Indoor Air – The indoor air has one or less order of magnitude of temporal variability. For example, indoor air concentrations of CFC-12 at location 826/494-IA-04 varied from 2.8 to 12 $\mu\text{g}/\text{m}^3$ (log of max./min. = 0.63). For PCE at location 826/494-IA-01, concentrations varied from 0.47 to 3.1 $\mu\text{g}/\text{m}^3$ (log max./min. = 0.82). Indoor air concentrations of TCE at 826/494-IA-02 varied from 0.22 to 1.6 $\mu\text{g}/\text{m}^3$ (log max./min. = 0.86). Overall, temporal variability across the four seasons sampled is relatively small.

Additional Analyses

Comparison of Sub-Slab Soil Gas and Indoor Air Data Sets – As expected, the sub-slab soil gas data exhibit greater spatial variability than the indoor air data set. The sub-slab soil gas also exhibits greater temporal variability than the indoor air data set, which is contrary to expectations. This suggests that there are not significant indoor sources of the AOIs or that emissions from any indoor air sources tend to be well distributed in this building.

Seasonal Effects – The sub-slab soil gas data exhibit relatively little variability from event to event. Maximum sub-slab soil gas values for CFC-12 occurred in E1 and E2 (fall and spring). For PCE and TCE, maximum sub-slab soil gas concentrations were detected in E4 and E3 (winter and summer), respectively. Maximum indoor air values for CFC-12 occurred in E4 (winter) and maximum detections for PCE and TCE occurred in E4 and E3 (winter and summer), respectively. The data do not support the hypothesis that wintertime should have the highest indoor air impacts.

Comparison of Attenuation Factors by Event – Attenuation factors were calculated for CFC-12, PCE and TCE based on maximum values. However, detections in outdoor air were very similar to detected indoor air concentrations for all three analytes. Therefore, the indoor air maximum concentration was corrected for contribution of outdoor air to indoor air (e.g., outdoor air detected concentration was subtracted from indoor air concentration). The calculated event-specific attenuation factors are shown in Tables 826/494-3A - 3C.

Table 826/494-3A. Comparison of Building-Specific Attenuation Factors for CFC-12 by Event

	E1 (Fall)	E2 (Spring)	E3 (Summer)	E4 (Winter)
Maximum Values				
CFC-12 in Sub-Slab Soil Gas ($\mu\text{g}/\text{m}^3$)	280,000	360,000	50,000	34,000
CFC-12 in Outdoor Air ($\mu\text{g}/\text{m}^3$)	2	2.4	2.4	2.5
CFC-12 in Indoor Air ($\mu\text{g}/\text{m}^3$)	3.7	4.1	4.8	8.9
CFC-12 in Indoor Air ($\mu\text{g}/\text{m}^3$) Corrected for Outdoor Air Contribution	1.7	1.7	2.4	6.4
Attenuation Factor	6.1E-06	4.7E-06	4.8E-05	1.9E-04

Table 826/494-3B. Comparison of Building-Specific Attenuation Factors for PCE by Event

	E1 (Fall)	E2 (Spring)	E3 (Summer)	E4 (Winter)
Maximum Values				
PCE in Sub-Slab Soil Gas ($\mu\text{g}/\text{m}^3$)	29,000	36,000	36,000	37,000
PCE in Outdoor Air ($\mu\text{g}/\text{m}^3$)	0.96	1.8	<0.23	0.84
PCE in Indoor Air ($\mu\text{g}/\text{m}^3$)	1.6	1.3	1.9	3.3
PCE in Indoor Air ($\mu\text{g}/\text{m}^3$) Corrected for Outdoor Air Contribution	0.64	--	1.9	2.5
Attenuation Factor	2.2E-05	3.6E-05	5.3E-05	6.8E-05

Table 826/494-3C. Comparison of Building-Specific Attenuation Factors for TCE by Event

	E1 (Fall)	E2 (Spring)	E3 (Summer)	E4 (Winter)
Maximum Values				
TCE in Sub-Slab Soil Gas ($\mu\text{g}/\text{m}^3$)	3,200	5,100	4,400	4,200
TCE in Outdoor Air ($\mu\text{g}/\text{m}^3$)	<0.17	0.23	0.34	<0.18
TCE in Indoor Air ($\mu\text{g}/\text{m}^3$)	0.22	0.39	2.6	0.34
TCE in Indoor Air ($\mu\text{g}/\text{m}^3$) Corrected for Outdoor Air Contribution	--	0.16	2.3	--
Attenuation Factor	6.9E-05	3.1E-05	5.2E-04	8.1E-05

These serve as the best estimates of attenuation at this building. The results can vary from day to day due to differences in rates of vapor intrusion and rates of building ventilation. Overall, the most conservative estimate of a building-specific attenuation factor for Building 826/494 is 5.2E-04 based on TCE during E3.

Temporal Variability in Attenuation Factor – As shown in Tables 826/494-3A - 3C, there was about one order of magnitude of temporal variability in the calculated attenuation factors observed for CFC-12, PCE, and TCE.

To be as conservative as possible, the maximum values were used in calculating the attenuation factor for each event. The sampling location with the maximum value per event varied. Generally, the maximum indoor air values were similar across events. In general, the low spatial variability in indoor air results means that roughly comparable attenuation factors would be obtained whichever indoor air value was used in the calculations.

NON-DETECT EVALUATION

If a sub-slab soil gas analyte has ND RL exceedances, but all results and ND RLs in indoor air are below the screening levels, no further evaluation is warranted. If an analyte was identified as an AOI in sub-slab soil gas (detected results > screening level), it is excluded from the ND evaluation. Also, if an ND analyte has an 0% detection frequency for all sampling events and all ND RLs met the screening level during at least one event, no further ND evaluation is warranted. Table 826/494-4 lists the 25 analytes that require no further evaluation regarding sub-slab soil gas ND RL exceedances. Table 826/494-5 provides a breakdown of the ND RLs for EDB, 1,2,4-TCB, and HCBd.

Table 826/494-4. SSSG Analytes with RLs that Exceed Screening Levels Requiring No ND Evaluation

Analyte	Number of Samples	Detection Rate	Percent of Sub-Slab Soil Gas Detection Limits Exceeding Screening Levels (Range from E1-E4)	Status in IA
1,1,2,2-Tetrachloroethane	6	0%	67-83%	All IA RLs met Screening Levels
1,1,2-Trichloroethane	6	0%	67-100%	
1,1-Dichloroethane	6	0%	0-17%	
1,2-Dichloroethane	6	0%	33-67%	
1,2-Dichloropropane	6	0%	0-17%	
1,3-Dichlorobenzene	6	0%	17-50%	
1,4-Dichlorobenzene	6	0%	0-17%	
1,4-Dioxane	6	0%	0-50%	
2-Hexanone	6	0%	0-17%	
alpha-Chlorotoluene	6	0%	67%	
Benzene	6	0%	0-17%	
Bromodichloromethane	6	0%	50-67%	
Bromoform	6	0%	0-17%	
Bromomethane	6	0%	0-50%	
Carbon tetrachloride	6	0%	0-17%	
Chloroform	6	4%	50-67%	
cis-1,2-Dichloroethene	6	0%	0-17%	
Cumene	6	0%	0-33%	
Dibromochloromethane	6	0%	50-67%	
Dibromomethane	6	0%	67%	
Ethylbenzene	6	4%	17-67%	
Naphthalene	6	0%	67%	
PCE	6	88%	0-17%	
TCE	6	58%	0-17%	
Vinyl chloride	6	0%	0-17%	

Table 826/494-5. ND Evaluation for SSSG Analytes with RLs that Exceed Screening Levels

Analyte	Number of Samples	Detection Rate	Sampling Event	Percent Exceed (ND RL) - MDEQ Project-Specific	# Samples RL met SL	Status in IA
1,2,4-Trichlorobenzene (1,2,4-TCB)	6	0%	E1	83%	1	IA RLs > SLs in all events: E1 (83% > SLs); E2 (83% > SLs); E3 (17% > SLs); E4 (67% > SLs).
			E2	67%	2	
			E3	67%	2	
			E4	67%	2	
1,2-Dibromoethane (EDB)	6	0%	E1	100%	0	All IA RLs > SLs
			E2	100%	0	
			E3	100%	0	
			E4	83%	1	
Hexachlorobutadiene (HCBD)	6	0%	E1	83%	1	All IA RLs > SLs
			E2	83%	1	
			E3	67%	2	
			E4	67%	2	

WEIGHT-OF-EVIDENCE SUMMARY

Building 826/494 was confirmed as a VI Path Forward Group 2 building due to its potential for VI based on sub-slab soil gas exceedances of the draft project-specific RIASL₁₂ and/or TSRIASL₁₂ for CFC-12, PCE, and TCE. However, after further investigation and evaluation, the following evidence supports the conclusion that VI is insignificant at Building 826/494:

- No exceedances of draft project-specific screening levels in indoor air.
- The sub-slab soil gas data do not show any strong time dependence nor do the data show any strong seasonal effects.
- The indoor air data show relatively little spatial variability, despite the greater spatial variability in the sub-slab soil gas values. This evaluation confirms that the sub-slab soil gas and indoor air concentrations were relatively constant from season to season.
- The typical parameters for non-residential exposures are assumed to apply but likely overestimate exposure for the personnel stationed at this building (i.e., 40 hours/week, 50 weeks/year exposure).
- As shown in the table below, the building-specific attenuation factor yields estimated indoor air concentrations for EDB, 1,2,4-TCB, and HCBD greater than the RIASL₁₂; however, lower reporting limits were achieved for each of these ND analytes in other events and the analytes remained ND. The maximum reporting limit listed in Table 826/494-5 is only one of two instances (the one listed being from E2 other being the same location during the E1 event) where estimated indoor air concentrations being determined from elevated sub-slab soil gas ND RLs exceed the RIASL₁₂. If any of the attenuation factors determined for either PCE, TCE, or CFC-12 are used from E1 or E2, the resulting estimated indoor air concentrations would be below the RIASL₁₂ values.

Parameters	EDB	1,2,4-TCB	HCBD
Building-specific AF	5.2E-04	5.2E-04	5.2E-04
Maximum reporting limit in SSSG	<5,900	<23,000	<33,000
Estimated Indoor Air Concentration	3.1	12	17
Indoor Air ND RL	<0.5	<12	<17
Indoor Air RIASL ₁₂	0.2	6.2	5.4

Based on the CSM for Building 826/494, VI is an insignificant exposure pathway for current building utilization.

PATH FORWARD

Based on the evaluation of the four seasonal confirmation sampling events, the VI pathway continues to be insignificant for Building 826/494 and the sub-slab soil gas results have demonstrated relatively stable concentrations and no evidence of increasing over time. Sufficient information exists to make a human exposure under control EI determination. However, while currently there is no evidence of potential VI, for future use, LTM is warranted and the implementation of the building-specific Interim Monitoring Plan began in August 2019.

Building-specific Interim Monitoring Plan

Dow presented an interim monitoring plan for Building 826/494 during the May 2019 Corrective Action status meeting. Interim monitoring began in August 2019.

Indoor air is monitored at location 826/494-IA-01 and 826/494-IA-02. These locations were selected for continued monitoring since it demonstrated the highest sub-slab soil gas results. Monitoring will be performed for CFC-12, PCE, and TCE. The indoor air result are shown below:

Indoor Air Analyte	Result Value (µg/m ³)	Reporting Limit (µg/m ³)	EGLE Project-Specific RIASL ₁₂ (µg/m ³)	NONRES TSRIASL ₁₂ (µg/m ³)	Dow IH OEL (8hr Time Weighted Average) (µg/m ³)
<i>Sample 826/494-IA-01</i>					
CFC-12	4.4	0.17	1020	NA	4,950,000
Tetrachloroethene	1.2	0.23	82	82	67,800
Trichloroethene	ND	0.18	4	12	26,850
<i>Sample 826/494-IA-02</i>					
CFC-12	4.3	0.17	1020	NA	4,950,000
Tetrachloroethene	1.1	0.23	82	82	67,800
Trichloroethene	ND	0.18	4	12	26,850

As shown on the table above, all indoor air result from the Summer 2019 IM event were ND with RLs below the indoor air RIASL₁₂. The analytical data is presented in Appendix A. Field sampling forms are provided in Appendix B. The next IM event is scheduled for Winter 2019/2020. Semi-annual interim monitoring will continue in the summer and winter of 2020. For future IM events, an outdoor air sample will also be collected at the time of each monitoring event.

5.4.6 Vapor Intrusion Evaluation Summary for Building 921

BACKGROUND

Building 921 is located in the southeastern quadrant of the Midland facility and is known as the Road and Yard Maintenance Shop. The building contains office space, conference rooms, locker rooms, a shop area, and kitchen/break rooms. The shop portion of the building is two stories tall and takes up roughly

two thirds of the building footprint. The southern third of the building is also two stories tall and contains offices, a kitchenette, a locker room, and storage area on the first floor; and a conference room, kitchen/break room, and locker rooms on the second floor. The structure has a footprint of 16,000 ft².

The building is heated through a combination of hot air circulation and steam via forced air. There is central AC for the office portion of the structure through three separate units (one for the first floor office space and two for the second floor conference room, kitchen/break room, and locker rooms). Ventilation fans are located in the bathrooms/locker rooms. The shop area has five bay doors, and two of them are open nearly 24 hours a day, 7 days a week. Gas-powered equipment and cans are stored in the main shop area.

Building 921 is occupied by site services personnel. The occupants work 8-hour shifts (7AM-3PM, 3PM-11PM) during the week. During the weekend, one person is on duty and works from 7AM-3PM. At any given time, approximately 11-13 people are in the building. Occupants use a contracted weekly laundry service or use washer/dryers located in the locker rooms.

SUB-SLAB SOIL GAS RESULTS EVALUATION SUMMARY

Building 921 was sampled in October 2017 and the VI evaluation was presented in Section 5.3.9 of the 2018 CAIP. Analytical results were evaluated based on methodologies presented in the 2018 Revised Vapor Intrusion Work Plan. Thirty-nine of the 65 analytes were ND in each of the samples. Twenty-six analytes were detected in sub-slab soil gas and all detected results were below the sub-slab soil gas draft project-specific RIASL₁₂ and TSRIASL₁₂, if available.

The 2017 VI sampling event demonstrated that all detections in sub-slab soil gas were less than screening levels. In indoor air, TCE was detected at concentrations that exceeded the RIASL₁₂ (4 µg/m³) in six of nine samples with two sample locations in the parts room and crib and others within office space that is directly linked to the shop floor. The detected indoor air concentrations only slightly exceeded screening levels and ranged from 4.1 - 5 µg/m³. TCE was not detected in sub-slab soil gas and the reporting limits met the RIASL₁₂ (130 µg/m³). TCE was also ND in the outdoor air sample. Summary statistics and screening comparison results are presented for sub-slab soil gas on Table 5.4.6-A and indoor and outdoor air on Table 5.4.6-B.

FURTHER INVESTIGATIVE FINDINGS SUMMARY

The goal of the further investigation activities was to confirm that the indoor air exceedances of TCE are due to active workplace chemical use and not attributable to VI. More specifically, activities were conducted to understand the distribution of TCE concentrations in the parts room and office area, located primarily on the eastern side of the building. The *Summary of VI Investigative Findings* for Building 921 was submitted to EGLE in October 2019 (Included in Appendix C).

During the July 15th investigation, the chemical inventory of the entire building was surveyed, and six TCE aerosol cans were found in the parts room. No TCE aerosol cans were found in the shop area or in the office area. It was also discovered that a HVAC unit directly connects the parts room and the offices. A second round of sampling was conducted that indicated that the TCE gradient originated from where the TCE cans were stored, then entered the HVAC, and eventually reached the offices.

TCE was not detected in sub-slab soil gas samples during the initial 2017 VI sample event. TCE results during the further investigation activities ranged from to 0.02 parts per billion by volume (ppbv) (0.11 µg/m³) to a maximum result of 0.40 ppbv (2.15 µg/m³). The maximum detected indoor air concentration of TCE during the further investigation was less than the RIASL₁₂ for TCE (4 µg/m³). The results demonstrated that the storage and use of TCE degreasers, particularly in the parts room, were the source of the elevated indoor air concentrations. Therefore, it was determined the source of elevated TCE concentrations in indoor air at Building 921 is due to active workplace chemical use and is not attributable to VI.

CONCLUSIONS AND RECOMMENDATIONS

The VI pathway at Building 921 is an insignificant exposure pathway based on current use. The further investigation activities conducted in July 2019 confirm that the indoor air exceedances detected at Building 921 are due to active workplace chemical use and not attributable to VI. No further action is warranted at this time for VI at Building 921.

5.4.7 VI Seasonal Confirmation Sampling Results Evaluation for Building 923

INTRODUCTION

Building 923 is located within the southeastern quadrant of the Midland facility and is a maintenance contractor building occupied by an on-site contractor known as Hydrochem (Figure 5.4.7-1). The initial evaluation in Section 5.3.4 of the 2018 CAIP concluded that based on the indoor air results, the VI pathway at Building 923 is an insignificant exposure pathway based on current use; however, based on the sub-slab soil gas results for eight analytes and given the potential for future VI, Building 923 was placed in VI Path Forward Building Group 4A, as lines of evidence indicate that VI is insignificant and the single indoor air exceedance of benzene was likely due to workplace chemical use or maintenance activities. Based on this grouping, seasonal confirmation sampling was implemented and completed in 2019.

Building 923	
Initial Sampling Event	Completed
E1	October 2017 (Fall)
Seasonal Sampling Event	Completed
E2	March 2018 (Spring)
E3	August 2018 (Summer)
E4	February 2019 (Winter 2019)

Based on the evaluation of the four seasonal confirmation sampling events, the VI pathway continues to be insignificant. Sufficient information exists to make a human exposure under control EI determination.

SUB-SLAB SOIL GAS RESULTS EVALUATION

Sub-slab soil gas samples were collected from nine locations from within the building. Indoor air samples were collected at nine locations corresponding to the soil gas sample locations, along with an outdoor air sample from the main air intake. The sampling locations are shown on Figure 5.4.7-2. Summary statistics and screening comparison results are presented for sub-slab soil gas on Table 5.4.7-A and indoor and outdoor air on Table 5.4.7-B. The analytical data is presented in Appendix A. Field sampling forms are provided in Appendix B. Table 923-1 presents the sub-slab soil gas results from seasonal confirmation sampling that exceed the draft project-specific screening levels.

Table 923-1. Summary of Sub-Slab Soil Gas Exceedances for Building 923

Analyte (Sampling Event)	Detection Frequency	Measured Range of Detects ($\mu\text{g}/\text{m}^3$)	% Detections > Screening Level	Screening Level* ($\mu\text{g}/\text{m}^3$)
1,2,4-Trimethylbenzene (1)	100%	6.8 - 17,000	22%	6,100
1,2,4-Trimethylbenzene (2)	100%	5.4 - 9,500	22%	6,100
1,2,4-Trimethylbenzene (3)	100%	4.8 - 11,000	22%	6,100
1,2,4-Trimethylbenzene (4)	56%	4 - 7,400	11%	6,100
1,2-Dichloropropane (1)	33%	6.1 - 820	22%	410
1,2-Dichloropropane (2)	0%	ND	0%	410
1,2-Dichloropropane (3)	0%	ND	0%	410
1,2-Dichloropropane (4)	0%	ND	0%	410

Table 923-1. Summary of Sub-Slab Soil Gas Exceedances for Building 923 (Continued)

Analyte (Sampling Event)	Detection Frequency	Measured Range of Detects (µg/m3)	% Detections > Screening Level	Screening Level* (µg/m3)
1,3,5-Trimethylbenzene (1)	78%	4.2 - 7,400	11%	6,100
1,3,5-Trimethylbenzene (2)	56%	4.8 - 4,100	0%	6,100
1,3,5-Trimethylbenzene (3)	67%	5.6 - 4,300	0%	6,100
1,3,5-Trimethylbenzene (4)	33%	4.4 - 2,300	0%	6,100
Benzene (1)	100%	12 - 260,000	22%	510
Benzene (2)	89%	4.5 - 170,000	22%	510
Benzene (3)	89%	3.8 - 180,000	22%	510
Benzene (4)	56%	13 - 82,000	22%	510
Cumene (1)	67%	4.4 - 7,100	22%	380
Cumene (2)	44%	4 - 1,400	11%	380
Cumene (3)	56%	4.1 - 1,800	11%	380
Cumene (4)	33%	5.7 - 2,100	11%	380
Ethylbenzene (1)	100%	13 - 73,000	22%	1,600
Ethylbenzene (2)	100%	6.9 - 11,000	11%	1,600
Ethylbenzene (3)	100%	4.2 - 19,000	22%	1,600
Ethylbenzene (4)	89%	3.5 - 22,000	22%	1,600
Naphthalene (1)	44%	18 - 19,000	22%	120
Naphthalene (2)	22%	19 - 3,300	11%	120
Naphthalene (3)	56%	13 - 5,700	22%	120
Naphthalene (4)	33%	15 - 7,500	22%	120
Total Xylenes (1)	100%	18.6 - 33,000	11%	22,000
Total Xylenes (2)	100%	16.5 - 18,000	0%	22,000
Total Xylenes (3)	100%	14 - 19,800	0%	22,000
Total Xylenes (4)	89%	16.8 - 10,900	0%	22,000

*Screening level provided is the draft project-specific RIASL₁₂.

Table 923-2 summarizes the indoor air results relative to the sub-slab soil gas exceedances, since VI only potentially occurs if the analyte is present in both sub-slab soil gas and indoor air. Therefore, the table below provides the analyte detected above applicable screening levels in sub-slab soil gas as well as the corresponding indoor air sample result. The outdoor air sample result is also provided to determine if the analytes were present in indoor air due to migration from outdoor air.

Table 923-2. Vapor Intrusion Evaluation for Building 923

Analyte (Sampling Event)	Indoor Air Detection Frequency	Indoor Air Measured Range (µg/m3)	Indoor Air Screening Level* (µg/m3)	Outdoor Air Result (µg/m3)
1,2,4-Trimethylbenzene (1)	100%	1.6 - 4	184	ND
1,2,4-Trimethylbenzene (2)	100%	11 - 47	184	ND
1,2,4-Trimethylbenzene (3)	22%	1.1 - 2	184	ND
1,2,4-Trimethylbenzene (4)	100%	3.8 - 6.3	184	ND
1,2-Dichloropropane (1)	0%	ND	12.2	ND
1,2-Dichloropropane (2)	0%	ND	12.2	ND
1,2-Dichloropropane (3)	0%	ND	12.2	ND
1,2-Dichloropropane (4)	0%	ND	12.2	ND
1,3,5-Trimethylbenzene (1)	11%	2	184	ND
1,3,5-Trimethylbenzene (2)	100%	3.5 - 15	184	ND
1,3,5-Trimethylbenzene (3)	0%	ND	184	ND
1,3,5-Trimethylbenzene (4)	89%	1.1 - 1.7	184	ND
Benzene (1)	100%	1.8 - 2.2	15.4	0.53
Benzene (2)	100%	11 - 20	15.4	0.45
Benzene (3)	100%	0.58 - 1.3	15.4	0.49
Benzene (4)	100%	6.1 - 9.3	15.4	0.82

Table 923-2. Vapor Intrusion Evaluation for Building 923 (Continued)

Analyte (Sampling Event)	Indoor Air Detection Frequency	Indoor Air Measured Range ($\mu\text{g}/\text{m}^3$)	Indoor Air Screening Level* ($\mu\text{g}/\text{m}^3$)	Outdoor Air Result ($\mu\text{g}/\text{m}^3$)
Cumene (1)	0%	ND	11.4	ND
Cumene (2)	100%	1.8 - 7.4	11.4	ND
Cumene (3)	0%	ND	11.4	ND
Cumene (3)	33%	0.82 - 1	11.4	ND
Ethylbenzene (1)	100%	1.4 - 2.5	48	0.27
Ethylbenzene (2)	100%	10 - 33	48	0.19
Ethylbenzene (3)	100%	0.19 - 0.35	48	0.18
Ethylbenzene (4)	100%	11 - 18	48	0.18
Naphthalene (1)	33%	0.44 - 0.57	3.6	ND
Naphthalene (2)	100%	0.93 - 3.4	3.6	ND
Naphthalene (3)	11%	1.1	3.6	ND
Naphthalene (4)	100%	0.74 - 1.8	3.6	0.94
Total Xylenes (1)	100%	6 - 13.2	680	0.77
Total Xylenes (2)	100%	39 - 122	680	0.84
Total Xylenes (3)	100%	0.6 - 1.6	680	0.49
Total Xylenes (4)	100%	75 - 123	680	0.69

*Screening level provided is the draft project-specific RIASL₁₂.

As shown in the table above, all indoor air results for Building 923, with the exception of a single result for benzene in E2, are below screening levels. Benzene exceeded the indoor air screening level at location 923-IA-01; however, sub-slab soil gas results at that location for each event were well below screening levels. The maximum benzene concentration in sub-slab soil gas at location 923-SS-01 was 180 $\mu\text{g}/\text{m}^3$ (RIASL₁₂ = 510 $\mu\text{g}/\text{m}^3$). Figure 923-1 shows results for benzene for each sample location. 1,2-Dichloroethane was not detected in sub-slab soil gas; however, during E4 it was detected in indoor air above the screening level (results ranged from 4.8 - 5 $\mu\text{g}/\text{m}^3$, RIASL₁₂ = 4.6 $\mu\text{g}/\text{m}^3$). All sub-slab soil gas results for EDC during all four events were ND, and during E4 all ND RLs were less than the screening level.

VAPOR INTRUSION CONCEPTUAL SITE MODEL

VI is an exposure pathway that results from the migration of volatilized chemicals from the subsurface to indoor air in overlying occupied buildings. A source, migration route and a human receptor must be present for the VI pathway to be complete. The focus of this building specific investigation is to evaluate the potential VI exposure pathway for employees and contractors at Building 969. The CSM is illustrated in Figure 5.4.7-3.

Building 923 was built between 1965 and 1982, with a small storage/shed-like area on its northwestern side built between 1982 and 1993. This building contains office space, locker rooms, a large shop area, storage areas, a wash bay, and a kitchen/break room. The shop portion of the building is two stories tall and takes up roughly two thirds of the building footprint. The first floor of the southeastern third of the building contains offices, a break room, a small bathroom, and a women's locker room. The second floor contains a conference room, kitchen/break room, a locker room, and offices. The structure is a slab-on-grade construction with no basement or elevator and has a footprint of 11,781 ft². The surrounding outdoor ground cover is asphalt.

The building is heated via hot air circulation and cooled via a combination of central and AC units. One intake is located on the roof and the other is located internal to the building just inside Door 5. This structure has five bay doors, with three of them being open nearly every day. Gas-powered equipment and cans are stored in the main shop area.

Approximately 10 to 20 people occupy this building at any given time. The occupants work 8 to 9 hour-long shifts five days a week. Occupants use a contracted weekly laundry service. The typical parameters for non-residential exposures are assumed to apply to the various personnel stationed during work shifts at this building (i.e., 40 hours/week, 50 weeks/year exposure).

The building survey was completed before the initial sampling event. Drains and other openings were screened with a PID. Three drain features were observed in this structure, one with a northwest-southeast orientation located on the southwest side of the shop, and two with a northeast-southwest orientation located on the east and west sides of the shop, respectively. A PID reading of 0.7 ppm was observed on the southeastern end of the northwest-southeast drain and PID readings of 0.5 and 3.4 ppm were observed on opposing ends of the eastern northeast-southwest oriented drain. A chemical inventory was completed during the building survey that identified motor oil, antifreeze, compressor oil, paint stripper, engine coating, enamel catalyst, xylene medium strength solvent, brake and parts cleaner, degreasers, antifoams, and lubricants.

EVALUATION OF SEASONAL CONFIRMATION SAMPLING EVENTS

Four seasonal sampling events and one interim monitoring event have been completed at Building 923. The sampling events encompass more than one year of time and include sampling during each season of the year. The results from the four seasonal confirmation sampling events were evaluated with respect to spatial variability, temporal variability, and seasonal trend analysis.

Building specific attenuation factors (α) were calculated and compared between events to evaluate temporal variability and determine the best estimate of a building-specific attenuation factor. This evaluation serves to confirm that the existing study design is appropriate, and also provides insight for the determination of the path forward for this building.

This evaluation focused on any analytes detected in the sub-slab soil gas samples that met the criterion for inclusion in one or more of the following categories:

- a) Analytes detected in sub-slab soil-gas at concentrations that exceeded draft project-specific screening levels;
- b) Analytes detected in sub-slab soil-gas at concentrations of 1,000 $\mu\text{g}/\text{m}^3$ or greater in one or more samples. Data for analytes detected above 1,000 $\mu\text{g}/\text{m}^3$ should provide the clearest signal and be the simplest to interpret when assessing data trends. The same data trends observed for these analytes are expected to apply to other similar analytes present at lower concentrations; and
- c) PCE and TCE. These two analytes are of particular interest for many VI evaluations at industrial sites.

For Building 923, eight analytes were detected in the sub-slab soil gas at concentrations above the draft project-specific screening levels: 1,2,4-TMB, 1,2-DCP, 1,3,5-TMB, benzene, cumene, ethylbenzene, naphthalene, and total xylenes. Seven additional analytes had a detected concentration $\geq 1,000 \mu\text{g}/\text{m}^3$: 4-ethyltoluene, acetone, cyclohexane, heptane, hexane, propylbenzene, and toluene. However, due to low detection frequencies, four of those analytes are not included for further evaluation (4-ethyltoluene, cyclohexane, heptane, and propylbenzene). Sample results for the eleven analytes are provided in the following data tables below:

Summary of Results for 1,2,4-Trimethylbenzene (TMB)

Sample Type	Sample ID	Measured Concentration ($\mu\text{g}/\text{m}^3$)			
		Oct. 2017	Mar. 2018	Aug. 2018	Feb. 2019
		E1	E2	E3	E4
Outdoor Air	923-OA-01	<0.84	<0.74	<0.8	<0.78
Indoor Air	923-IA-01	1.8	47	<0.76	4.6
	923-IA-02	1.7	31	<0.84	4.5
	923-IA-03	2.1	16	<0.81	4.7
	923-IA-04	1.9	31	<0.77	6.2
	923-IA-05	4	11	2	3.8
	923-IA-06	1.6	20	<0.82	6.3
	923-IA-07	1.6	20	1.1	6
	923-IA-08	2.1	16	<0.82	6
	923-IA-09	2	28	<0.78	5.4
Sub-Slab Soil Gas	923-SS-01	35	6.3	110	<3.8
	923-SS-02	10	20	88	4
	923-SS-03	9.7	17	25	7.6
	923-SS-04	17,000	7,400	10,000	7,400
	923-SS-05	6.8	5.4	5.4	<3.5
	923-SS-06	14	7.2	4.8	<3.8
	923-SS-07	25	5.9	4.8	<3.6
	923-SS-08	26	49	23	15
	923-SS-09	15,000	9,500	11,000	1,200

Screening levels for indoor air are $184 \mu\text{g}/\text{m}^3$ (RIASL₁₂) and $560 \mu\text{g}/\text{m}^3$ (TSRIASL₁₂)
Screening levels for soil-gas are $6,100 \mu\text{g}/\text{m}^3$ (RIASL₁₂) and $18,000 \mu\text{g}/\text{m}^3$ (TSRIASL₁₂)

Summary of Results for 1,2-Dichloropropane

Sample Type	Sample ID	Measured Concentration ($\mu\text{g}/\text{m}^3$)			
		Oct. 2017	Mar. 2018	Aug. 2018	Feb. 2019
		E1	E2	E3	E4
Outdoor Air	923-OA-01	<0.79	<0.69	<0.75	<0.73
Indoor Air	923-IA-01	<0.76	<0.82	<0.71	<0.84
	923-IA-02	<0.76	<0.78	<0.78	<0.76
	923-IA-03	<0.74	<0.77	<0.76	<0.84
	923-IA-04	<0.76	<0.80	<0.72	<0.88
	923-IA-05	<0.81	<0.80	<0.78	<0.76
	923-IA-06	<0.87	<0.77	<0.77	<2.1
	923-IA-07	<0.80	<0.81	<0.74	<0.78
	923-IA-08	<0.81	<1.6	<0.78	<0.76
	923-IA-09	<0.87	<0.74	<0.73	<0.95
Sub-Slab Soil Gas	923-SS-01	6.1	<3.4	<7.3	<3.6
	923-SS-02	<3.7	<3.6	<3.8	<3.4
	923-SS-03	<3.8	<3.8	<3.7	<3.7
	923-SS-04	820	<350	<350	<72
	923-IA-05	<3.7	<3.4	<4	<3.3
	923-IA-06	<3.7	<3.6	<3.4	<3.5
	923-IA-07	<8.6	<3.8	<3.6	<3.4
	923-IA-08	<3.5	<3.8	<3.6	<3.8
	923-IA-09	480	<190	<71	<68

Screening levels for indoor air are $12.2 \mu\text{g}/\text{m}^3$ (RIASL₁₂)
Screening levels for soil-gas are $410 \mu\text{g}/\text{m}^3$ (RIASL₁₂)

	RIASL12 Exceedance
	TSRIASL12 Exceedance

Summary of Results for 1,3,5-Trimethylbenzene (TMB)

Sample Type	Sample ID	Measured Concentration ($\mu\text{g}/\text{m}^3$)			
		Oct. 2017	Mar. 2018	Aug. 2018	Feb. 2019
		E1	E2	E3	E4
Outdoor Air	923-OA-01	<0.84	<0.74	<0.80	<0.78
Indoor Air	923-IA-01	<0.81	15	<0.76	1.3
	923-IA-02	<0.81	9.4	<0.84	1.2
	923-IA-03	<0.79	5.1	<0.81	1.3
	923-IA-04	<0.81	9.2	<0.77	1.6
	923-IA-05	2	3.5	<0.84	1.1
	923-IA-06	<0.92	6.3	<0.82	<2.2
	923-IA-07	<0.85	6.6	<0.79	1.7
	923-IA-08	<0.86	5.1	<0.82	1.6
	923-IA-09	<0.92	8.5	<0.78	1.6
Sub-Slab Soil Gas	923-SS-01	10	<3.6	51	<3.8
	923-SS-02	4.7	7.5	46	<3.6
	923-SS-03	4.2	4.8	5.6	<3.9
	923-SS-04	7,400	4,100	4,300	2,300
	923-SS-05	<3.9	<3.6	<4.3	<3.5
	923-SS-06	4.7	<3.8	<3.7	<3.8
	923-SS-07	<9.1	<4.1	<3.8	<3.6
	923-SS-08	11	20	10	4.4
	923-SS-09	5,700	4,000	4,300	720

Screening levels for indoor air are $184 \mu\text{g}/\text{m}^3$ (RIASL₁₂) and $560 \mu\text{g}/\text{m}^3$ (TSRIASL₁₂)
Screening levels for soil-gas are $6,100 \mu\text{g}/\text{m}^3$ (RIASL₁₂) and $18,000 \mu\text{g}/\text{m}^3$ (TSRIASL₁₂)

Summary of Results for Benzene

Sample Type	Sample ID	Measured Concentration ($\mu\text{g}/\text{m}^3$)			
		Oct. 2017	Mar. 2018	Aug. 2018	Feb. 2019
		E1	E2	E3	E4
Outdoor Air	923-OA-01	<0.27	<0.24	<0.26	<0.25
Indoor Air	923-IA-01	1.9	20	0.61	7.3
	923-IA-02	2.2	14	0.67	7.6
	923-IA-03	2.1	11	0.95	7.2
	923-IA-04	1.9	15	0.63	9.3
	923-IA-05	2.2	11	0.60	6.1
	923-IA-06	1.8	13	0.66	8.4
	923-IA-07	1.8	13	0.59	8.3
	923-IA-08	1.9	12	0.58	8.5
	923-IA-09	2	14	1.3	7.3
Sub-Slab Soil Gas	923-SS-01	96	16	180	13
	923-SS-02	31	23	50	60
	923-SS-03	12	5.2	6.9	<2.5
	923-SS-04	260,000	170,000	180,000	76,000
	923-SS-05	12	4.5	7.2	<2.3
	923-SS-06	13	4.9	3.8	<2.4
	923-SS-07	17	13	<2.5	<2.3
	923-SS-08	260	34	11	230
	923-SS-09	160,000	77,000	97,000	82,000

Screening levels for indoor air are $15.4 \mu\text{g}/\text{m}^3$ (RIASL₁₂) and $54 \mu\text{g}/\text{m}^3$ (TSRIASL₁₂)
Screening levels for soil-gas are $510 \mu\text{g}/\text{m}^3$ (RIASL₁₂) and $1,800 \mu\text{g}/\text{m}^3$ (TSRIASL₁₂)

	RIASL12 Exceedance
	TSRIASL12 Exceedance

Summary of Results for Cumene

Sample Type	Sample ID	Measured Concentration (µg/m³)			
		Oct. 2017	Mar. 2018	Aug. 2018	Feb. 2019
		E1	E2	E3	E4
Outdoor Air	923-OA-01	<0.84	<0.74	<.8	<0.78
Indoor Air	923-IA-01	<0.81	7.4	<0.76	<0.90
	923-IA-02	<0.81	4.7	<0.84	<0.81
	923-IA-03	<0.79	2.3	<0.81	<0.90
	923-IA-04	<0.81	4.6	<0.77	<0.94
	923-IA-05	<0.86	1.8	<0.84	0.82
	923-IA-06	<0.92	3.2	<0.82	<2.2
	923-IA-07	<0.85	3.3	<0.79	0.85
	923-IA-08	<0.86	2.4	<0.82	1
	923-IA-09	<0.92	4.7	<0.78	<1
Sub-Slab Soil Gas	923-SS-01	31	4	30	<3.8
	923-SS-02	4.4	9.5	38	<3.6
	923-SS-03	<4.1	<4	<4	<3.9
	923-SS-04	7,100	1,400	1,800	2,100
	923-SS-05	<3.9	<3.6	<4.3	<3.5
	923-SS-06	<4	<3.8	<3.7	<3.8
	923-SS-07	14	<4.1	<3.8	<3.6
	923-SS-08	9.7	7.6	4.1	5.7
	923-SS-09	5,000	<200	190	100

Screening levels for indoor air are 11.4 µg/m³ (RIASL₁₂)
Screening levels for soil-gas are 380 µg/m³ (RIASL₁₂)

Summary of Results for Ethylbenzene

Sample Type	Sample ID	Measured Concentration (µg/m³)			
		Oct. 2017	Mar. 2018	Aug. 2018	Feb. 2019
		E1	E2	E3	E4
Outdoor Air	923-OA-01	<0.15	<0.13	<0.14	<0.14
Indoor Air	923-IA-01	1.4	33	0.33	11
	923-IA-02	1.5	20	0.34	12
	923-IA-03	1.6	12	0.24	14
	923-IA-04	1.4	22	0.19	14
	923-IA-05	2.1	10	0.28	16
	923-IA-06	1.6	15	0.30	12
	923-IA-07	1.6	15	0.26	14
	923-IA-08	2.5	12	0.29	18
	923-IA-09	1.6	21	0.35	12
Sub-Slab Soil Gas	923-SS-01	160	45	380	6.2
	923-SS-02	62	120	150	17
	923-SS-03	14	11	18	6.9
	923-SS-04	73,000	11,000	19,000	22,000
	923-SS-05	13	6.9	4.2	<3.1
	923-SS-06	34	30	18	3.6
	923-SS-07	440	78	35	3.5
	923-SS-08	220	230	140	120
	923-SS-09	56,000	1,400	3,700	2,900

Screening levels for indoor air are 48 µg/m³ (RIASL₁₂) and 480 µg/m³ (TSRIASL₁₂)
Screening levels for soil-gas are 1,600 µg/m³ (RIASL₁₂) and 16,000 µg/m³ (TSRIASL₁₂)

	RIASL12 Exceedance
	TSRIASL12 Exceedance

Summary of Results for Naphthalene

Sample Type	Sample ID	Measured Concentration ($\mu\text{g}/\text{m}^3$)			
		Oct. 2017	Mar. 2018	Aug. 2018	Feb. 2019
		E1	E2	E3	E4
Outdoor Air	923-OA-01	<0.45	<0.39	<0.43	<0.41
Indoor Air	923-IA-01	<0.43	3.4	<0.40	1.4
	923-IA-02	<0.43	3.2	<0.44	1.4
	923-IA-03	0.44	1.1	<0.43	1.4
	923-IA-04	0.44	2.5	<0.41	1.8
	923-IA-05	<0.46	0.93	<0.44	0.74
	923-IA-06	<0.49	1.8	<0.44	1.7
	923-IA-07	<0.45	1.6	<0.42	1.7
	923-IA-08	<0.46	1.1	1.1	1.3
	923-IA-09	0.57	2.1	<0.41	1.5
Sub-Slab Soil Gas	923-SS-01	18	<7.6	86	<8.2
	923-SS-02	<8.4	<8.2	22	<7.6
	923-SS-03	<8.8	<8.5	<8.5	<8.3
	923-SS-04	16,000	3,300	5,700	7,500
	923-SS-05	<8.3	<7.7	<9.2	<7.5
	923-SS-06	<8.5	<8.2	<7.8	<8
	923-SS-07	<19	<8.8	<8.2	<7.7
	923-SS-08	50	19	13	15
	923-SS-09	19,000	<850	940	820

Screening levels for indoor air are $3.6 \mu\text{g}/\text{m}^3$ (RIASL₁₂)

Screening levels for soil-gas are $120 \mu\text{g}/\text{m}^3$ (RIASL₁₂)

Summary of Results for Total Xylenes

Sample Type	Sample ID	Measured Concentration ($\mu\text{g}/\text{m}^3$)			
		Oct. 2017	Mar. 2018	Aug. 2018	Feb. 2019
		E1	E2	E3	E4
Outdoor Air	923-OA-01	0.77	0.84	0.49	0.69
Indoor Air	923-IA-01	6.2	122	1.6	75
	923-IA-02	6.6	79	1.57	1.33
	923-IA-03	6.5	48	0.75	95
	923-IA-04	6	82	0.60	88
	923-IA-05	13.2	39	0.96	112
	923-IA-06	8	59	1.06	78
	923-IA-07	7.9	59	0.95	93
	923-IA-08	12.2	50	1.06	123
	923-IA-09	6.8	78	1.25	88
Sub-Slab Soil Gas	923-SS-01	1,190	310	3,200	29
	923-SS-02	520	1,090	1,130	45
	923-SS-03	18.6	31	50	35.4
	923-SS-04	33,000	18,000	19,800	10,900
	923-SS-05	23.3	16.5	14	<6.2
	923-SS-06	211	166	107	16.8
	923-SS-07	4,100	600	266	22
	923-SS-08	453	1,000	620	151
	923-SS-09	18,700	15,800	15,200	4,000

Screening levels for indoor air are $680 \mu\text{g}/\text{m}^3$ (RIASL₁₂) and $2,000 \mu\text{g}/\text{m}^3$ (TSRIASL₁₂)
Screening levels for soil-gas are $22,000 \mu\text{g}/\text{m}^3$ (RIASL₁₂) and $67,000 \mu\text{g}/\text{m}^3$ (TSRIASL₁₂)

	RIASL12 Exceedance
	TSRIASL12 Exceedance

Summary of Results for Acetone

Sample Type	Sample ID	Measured Concentration ($\mu\text{g}/\text{m}^3$)			
		Oct. 2017	Mar. 2018	Aug. 2018	Feb. 2019
		E1	E2	E3	E4
Outdoor Air	923-OA-01	5	6.8	16	8.3
Indoor Air	923-IA-01	160	200	29	36
	923-IA-02	150	200	29	39
	923-IA-03	120	150	16	87
	923-IA-04	190	220	15	35
	923-IA-05	160	180	30	91
	923-IA-06	150	180	18	42
	923-IA-07	160	210	8.5	43
	923-IA-08	210	190	15	93
	923-IA-09	170	180	18	52
Sub-Slab Soil Gas	923-SS-01	300	110	1,000	<18
	923-SS-02	330	570	570	64
	923-SS-03	180	130	140	49
	923-SS-04	<1,200	<710	<720	290
	923-SS-05	61	44	49	19
	923-SS-06	140	76	120	<18
	923-SS-07	240	80	110	59
	923-SS-08	180	370	260	41
	923-SS-09	1,200	870	1,200	470

Screening levels for indoor air are 31,000 $\mu\text{g}/\text{m}^3$ (RIASL₁₂/TSRIASL₁₂)
Screening levels for soil-gas are 1,000,000 $\mu\text{g}/\text{m}^3$ (RIASL₁₂/TSRIASL₁₂)

Summary of Results for Hexane

Sample Type	Sample ID	Measured Concentration ($\mu\text{g}/\text{m}^3$)			
		Oct. 2017	Mar. 2018	Aug. 2018	Feb. 2019
		E1	E2	E3	E4
Outdoor Air	923-OA-01	<0.6	<0.53	<0.57	<0.56
Indoor Air	923-IA-01	3.3	44	0.8	6.5
	923-IA-02	3.8	28	1.1	7
	923-IA-03	3.2	24	1.3	6.6
	923-IA-04	3.4	31	0.91	8.5
	923-IA-05	3.8	23	0.84	6.5
	923-IA-06	2.7	26	0.8	7.9
	923-IA-07	3	26	<0.56	8.3
	923-IA-08	3.1	24	0.85	9.1
	923-IA-09	3.7	30	13	6.8
Sub-Slab Soil Gas	923-SS-01	66	6.9	54	<2.7
	923-SS-02	69	20	45	13
	923-SS-03	22	7.5	15	4.2
	923-SS-04	19,000	13,000	18,000	5,100
	923-SS-05	13	<2.6	<3.1	3.5
	923-SS-06	24	12	8.8	<2.7
	923-SS-07	32	<2.9	5.3	5.8
	923-SS-08	38	14	16	11
	923-SS-09	11,000	6,400	8,700	10,000

Screening levels for indoor air are 2,200 $\mu\text{g}/\text{m}^3$ (RIASL₁₂/TSRIASL₁₂)
Screening levels for soil-gas are 72,000 $\mu\text{g}/\text{m}^3$ (RIASL₁₂/TSRIASL₁₂)

	RIASL12 Exceedance
	TSRIASL12 Exceedance

Summary of Results for Toluene

Sample Type	Sample ID	Measured Concentration ($\mu\text{g}/\text{m}^3$)			
		Oct. 2017	Mar. 2018	Aug. 2018	Feb. 2019
		E1	E2	E3	E4
Outdoor Air	923-OA-01	3.1	1.8	0.66	0.68
Indoor Air	923-IA-01	9.8	100	1.9	17
	923-IA-02	9.8	69	2	18
	923-IA-03	12	53	1.3	18
	923-IA-04	9.5	74	0.92	22
	923-IA-05	10	49	2	16
	923-IA-06	8.9	70	1.3	21
	923-IA-07	9	60	1.4	21
	923-IA-08	11	56	1.4	22
	923-IA-09	16	87	3.5	18
Sub-Slab Soil Gas	923-SS-01	300	82	390	30
	923-SS-02	63	250	110	110
	923-SS-03	73	200	720	230
	923-SS-04	1,600	560	1,000	690
	923-IA-05	26	12	8.3	10
	923-IA-06	91	21	12	120
	923-IA-07	89	10	7.4	17
	923-IA-08	220	210	33	270
	923-IA-09	1,600	590	1,100	570

Screening levels for indoor air are $7,600 \mu\text{g}/\text{m}^3$ (RIASL₁₂/TSRIASL₁₂)

Screening levels for soil-gas are $250,000 \mu\text{g}/\text{m}^3$ (RIASL₁₂/TSRIASL₁₂)

	RIASL12 Exceedance
	TSRIASL12 Exceedance

EVALUATION OF VI DATA TRENDS

Data trends for Building 923 are discussed below for both sub-slab soil gas and indoor air. When data exhibit a narrow range of variability, it is typical practice to express the range as a percentage (e.g., relative percent difference [RPD]). When data exhibit a large range of variability, however, it is more useful to express the range in orders of magnitude (i.e., factors of 10). This can be expressed mathematically as the log of the ratio of maximum/minimum values. If the values differ by a factor of 10, the log of the ratio is 1, if the values differ by a factor of 100, the log of the ratio is 2, and so on.

The variability across all locations over all sampling events is the total variability. This encompasses different types of variability, including spatial variability (i.e., how do the results vary from location to location), temporal variability (i.e., how do the results at a given location vary over time), and measurement variability. Measurement variability can be determined by evaluating results of duplicate or collocated samples and includes both sampling variability and analytical variability.

Sub-Slab Soil Gas Data Trends

Spatial Variability of Sub-Slab Soil Gas –The sub-slab soil gas detections exhibit up to four orders of magnitude of spatial variability. The greatest spatial variability was observed during for benzene during E3 with detections ranging 3.8 to $180,000 \mu\text{g}/\text{m}^3$ (log of max./min. =4.68). The lowest variability was observed during E1 with acetone detections ranging from 61 to $1,200 \mu\text{g}/\text{m}^3$ (log of max./min. =1.29).

Temporal Variability of Soil Gas – The sub-slab soil gas detections exhibit up to two orders of magnitude temporal variability. The greatest temporal variability was observed for total xylenes at 923-SS-07 with detections ranging from 22 to $4,100 \mu\text{g}/\text{m}^3$ (log of max./min. =2.27). The lowest temporal variability was observed for 1,2,4-TMB at location 923-SS-05 with detections ranging from 5.4 to 6.8

$\mu\text{g}/\text{m}^3$ (log of max./min. = 0.1). Overall, as expected, the amount of temporal variability is less than the amount of spatial variability.

Seasonal Confirmation Sampling Trend Analysis – No formal statistical tests were performed, but the data exhibits relatively consistent results between the seasons. This is demonstrated by the graphs below for results of seven of the analytes in this assessment at sample location 923-SS-04. This location was chosen because it consistently had the highest detections across all four events. Note that the y-axes are a log scale.

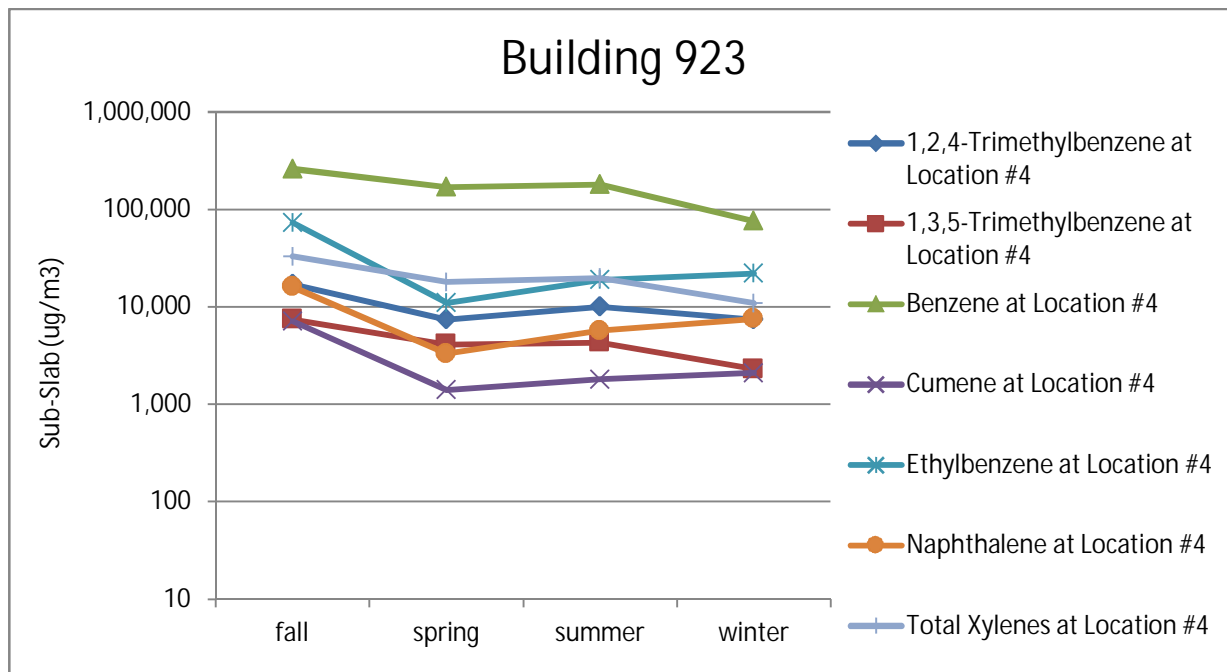

The data set was examined to see what the potential consequences would have been had only a single sampling event been performed. For Building 923, the highest sub-slab soil gas concentrations were collected during the fall (E1) and the lowest concentrations occurred during the spring (E2) or winter (E4), respectively. Therefore, implementing four seasonal confirmation sampling events provided only limited insight regarding maximum concentration levels, but the larger data set served to increase the confidence in the findings including demonstrating the consistency of the maximum reported results.

Indoor Air Data Trends

Spatial Variability of Indoor Air – The indoor air exhibits anywhere from 20% to two orders of magnitude of spatial variability with most spatial variability values for this data set ranging from log max/min = 0.11 to 0.55. The greatest spatial variability in indoor air was observed during E4 for total xylene detections ranging from 1.33 to 123 $\mu\text{g}/\text{m}^3$ (log max./min. = 1.97). For benzene, results ranged from 11 to 20 $\mu\text{g}/\text{m}^3$ (log max./min. = 0.26).

Temporal Variability of Indoor Air – The indoor air has anywhere from 5% to slightly more than two orders of magnitude of temporal variability. Total xylenes at location 923-IA-04 showed the greatest temporal variability with detections ranging from 6 to 88 $\mu\text{g}/\text{m}^3$ (log max./min. = 2.17). Naphthalene saw the least temporal variability with detections ranging from 1.7 to 1.8 $\mu\text{g}/\text{m}^3$ at 923-IA-06 (log max./min. = 0.02). Overall, temporal variability across the four seasons sampled is slightly greater than the spatial variability.

Additional Analyses

Comparison of Sub-Slab Soil Gas and Indoor Air Data Sets – As expected, the sub-slab soil gas data exhibit greater spatial variability than the indoor air data set. The sub-slab soil gas exhibits similar temporal variability to the indoor air data set, which is contrary to expectations. Additionally, the temporal variability in the indoor air data set suggests that there are significant indoor sources of the AOIs and/or they are in use, and with said use the emissions vary greatly over time and/or are not well distributed in the building.

Seasonal Effects – The sub-slab soil gas data exhibit some variability from event to event but are generally consistent. The highest sub-slab soil gas exceedances were seen during E1 (fall) and the lowest results were typically observed during spring (E2) and winter (E4). Maximum indoor air values for most of the analytes evaluated occurred in the spring (E2). The data do not support the hypothesis that wintertime should have the highest indoor air impacts.

Comparison of Attenuation Factors by Event – Attenuation factors were calculated for 1,2,4-TMB based on maximum values since 1,2,4-TMB had 100% detection frequency in both media and no detections in outdoor air. The calculated event-specific attenuation factors are shown in Tables 923-3.

Table 923-3. Comparison of Building-Specific Attenuation Factors for 1,2,4-TMB by Event

	E1 (Fall)	E2 (Spring)	E3 (Summer)	E4 (Winter)
Maximum Values				
1,2,4-TMB in Sub-Slab Soil Gas ($\mu\text{g}/\text{m}^3$)	17,000	9,500	11,000	7,400
1,2,4-TMB in Indoor Air ($\mu\text{g}/\text{m}^3$)	4	47	2	6.3
Attenuation Factor	2.4E-04	5.0E-03	1.8E-04	8.5E-04

These serve as the best estimates of attenuation at this building. The results can vary from day to day due to differences in rates of vapor intrusion and rates of building ventilation. Overall, the most conservative estimate of a building-specific attenuation factor for Building 923 is 5.0E-03 based on 1,2,4-TMB during E2.

Temporal Variability in Attenuation Factor – As shown in Table 923-3, there was about one order of magnitude of temporal variability in the calculated attenuation factors observed for 1,2,4-TMB. To be as conservative as possible, the maximum values were used in calculating the attenuation factor for each event. The sampling location with the maximum value per event varied. Generally, the maximum indoor air values were similar across events.

NON-DETECT EVALUATION

Table 923-4 below lists the analytes in sub-slab soil gas that have ND RLs greater than the screening levels. The table also includes the indoor air results for each of the analytes. If a sub-slab soil gas analyte has ND RL exceedances, but all results and ND RLs in indoor air are below the screening levels, no further evaluation is warranted. Also, if the analyte has already been identified as an AOI in sub-slab soil gas, no further ND evaluation is warranted. If an analyte was identified as an AOI in sub-slab soil gas (detected results > screening level), it is excluded from the ND evaluation. Also, if an ND analyte has an 0% detection frequency for all sampling events and all ND RLs met the screening level during at least one event, no further ND evaluation is warranted.

Table 923-4. Non-Detect Evaluation for Building 923

Soil Gas Analytes with ND RL > SL	Indoor Air Result Summary
1,1,2,2-Tetrachloroethane	0% Detection Frequency, All ND RLs < RIASL ₁₂
1,1,2-Trichloroethane	0% Detection Frequency, All ND RLs < RIASL ₁₂
1,2,4-Trichlorobenzene	0% Detection Frequency, 17 ND RLs > RIASL ₁₂
1,2-Dibromoethane (EDB)	0% Detection Frequency, All ND RLs > RIASL ₁₂
1,2-Dichloroethane	0%-100% Detection Frequency, All detects and ND RLs < RIASL ₁₂
1,3-Dichlorobenzene	0% Detection Frequency, All ND RLs < RIASL ₁₂
1,4-Dioxane	0%-44% Detection Frequency, All detects and ND RLs < RIASL ₁₂
alpha-Chlorotoluene	0% Detection Frequency, All ND RLs < RIASL ₁₂
Bromodichloromethane	0% Detection Frequency, All ND RLs < RIASL ₁₂
Bromomethane	0% Detection Frequency, All ND RLs < RIASL ₁₂
Carbon tetrachloride	100% Detection Frequency, All Detects < RIASL ₁₂
Chloroform	89%-100% Detection Frequency, All detects and ND RLs < RIASL ₁₂
Dibromochloromethane	0% Detection Frequency, All ND RLs < RIASL ₁₂
Dibromomethane	0% Detection Frequency, All but one ND RLs < RIASL ₁₂
Hexachlorobutadiene (HCBD)	0% Detection Frequency, All ND RLs > RIASL ₁₂ , 78% SSSG ND RLs < RIASL ₁₂
Trichloroethene	0% - 100% Detection Frequency, All detects and ND RLs < RIASL ₁₂

Elevated sub-slab soil gas benzene detections (and to a lesser extent, ethyl benzene detections) at locations 923-SS-04 and 923-SS-09 during all four sampling events are causing elevated ND RLs in sub-slab soil gas for some analytes. Benzene was only detected above its RIASL₁₂ once throughout all four sampling events and the exceedance was not at one of these two locations.

WEIGHT-OF-EVIDENCE SUMMARY

Building 923 was confirmed as a VI Path Forward Group 2 building due to its potential for VI based on sub-slab soil gas exceedances of the draft project-specific RIASL₁₂ and/or TSRIASL₁₂ for 1,2,4-TMB, 1,2-DCP, 1,3,5-TMB, benzene, cumene, ethylbenzene, naphthalene, and total xylenes. After E2, Building 923 was confirmed as a Group 4A, as lines of evidence indicate that VI is insignificant and the single indoor air exceedance of benzene was likely due to workplace chemical use or maintenance activities. Seasonal confirmation sampling was conducted. However, after further investigation and evaluation, the following evidence supports the conclusion that VI is insignificant at Building 923:

- The sub-slab soil gas data do not show any strong time dependence nor do the data show any strong seasonal effects.
- For the analytes with exceedances of sub-slab soil gas screening levels, only one detection in indoor air exceeded the screening level during all four sampling events.
- The temporal variability in the indoor air data set suggests that there are significant indoor sources of the AOIs or that emissions from any indoor air sources are not well distributed in the building.
- The indoor air data show relatively little spatial variability in comparison to the greater spatial variability in the sub-slab soil gas values. This evaluation confirms that the sub-slab soil gas and indoor air concentrations were relatively constant from season to season.
- As shown in the table below, the conservative building-specific attenuation factor yields estimated indoor air concentrations for EDB, 1,2,4-TCB, and HCBD near or below the RIASL₁₂. For Building 923, E4 provided significantly lower ND RLs; therefore, the maximum ND RLs from E4 (sample location 923-SS-04) were used to estimate indoor air concentrations for the three ND analytes.

Parameters	EDB	1,2,4-TCB	HCBD
Building-specific AF	5.0E-03	5.0E-03	5.0E-03
Maximum ND reporting limit in E4 SSSG	<120	<460	<660
Paired Indoor Air ND RL	<0.29	<7.1	<10
Estimated Indoor Air Concentration	0.6	2.5	3.3
Indoor Air RIASL ₁₂	0.2	6.2	5.4

Based on the CSM for Building 923, VI is an insignificant exposure pathway for current building utilization.

PATH FORWARD

Based on the evaluation of the four seasonal confirmation sampling events, the VI pathway continues to be insignificant for Building 923 and the sub-slab soil gas results have demonstrated relatively stable concentrations and no evidence of increasing over time. Sufficient information exists to make a human exposure under control EI determination. However, while currently there is no evidence of potential VI, for future use, LTM is warranted and the building-specific Interim Monitoring Plan is discussed below.

Building-specific Interim Monitoring Plan

Dow implemented an interim monitoring plan for Building 923 in summer 2019, which was shared with EGLE during the May 2019 Corrective Action status meeting. Dow will implement the interim monitoring plan at Building 923 until a revised program or more permanent corrective action plan is developed for the site.

Interim monitoring began in August 2019. Indoor air is being monitored at location 923-IA-04 and 923-IA-09. These locations were selected for continued monitoring since it demonstrated the highest sub-slab soil gas results. Monitoring will be performed for 1,2,4-TMB, 1,2-DCP, 1,3,5-TMB, benzene, cumene, ethylbenzene, naphthalene, and total xylenes. An outdoor air sample is also collected at the time of each monitoring event. Interim monitoring will be performed semi-annually for a minimum of two years and monitoring results will undergo trend analysis. The screened results are shown below:

Indoor Air Analyte	Result Value (µg/m ³)	Reporting Limit (µg/m ³)	EGLE Project-Specific RIASL ₁₂ (µg/m ³)	NONRES TSRIASL ₁₂ (µg/m ³)	Dow IH OEL (8hr Time Weighted Average) (µg/m ³)
<i>Sample 923-IA-04</i>					
1,2,4-Trimethylbenzene	ND	0.86	184	560	125,000
1,2-Dichloropropane	ND	0.81	12.2	NA	46,200
1,3,5-Trimethylbenzene	ND	0.86	184	560	125,000
Benzene	0.46	0.28	15.4	54	1,595
Cumene	ND	0.86	11.4	NA	246,000
Ethyl Benzene	2.1	0.15	48	480	86,800
Naphthalene	ND	0.46	3.6	NA	52,400
Total Xylenes	ND	0.45	680	2000	434,000
<i>Sample 923-IA-09</i>					
1,2,4-Trimethylbenzene	ND	0.86	184	560	125,000
1,2-Dichloropropane	ND	0.81	12.2	NA	46,200
1,3,5-Trimethylbenzene	ND	0.86	184	560	125,000
Benzene	0.44	0.28	15.4	54	1,595
Cumene	ND	0.86	11.4	NA	246,000
Ethyl Benzene	1.5	0.15	48	480	86,800
Naphthalene	ND	0.46	3.6	NA	52,400
Total Xylenes	ND	0.45	680	2000	434,000

As shown in the table above, all indoor air results from the summer 2019 IM event had detected results below the RIASL₁₂ or were ND with RLs below the indoor air RIASL₁₂. The analytical data is presented in Appendix A. Field sampling forms are provided in Appendix B. The next IM event is scheduled for winter 2019/2020. Semi-annual interim monitoring will continue in the summer and winter of 2020.

Figure 923-1

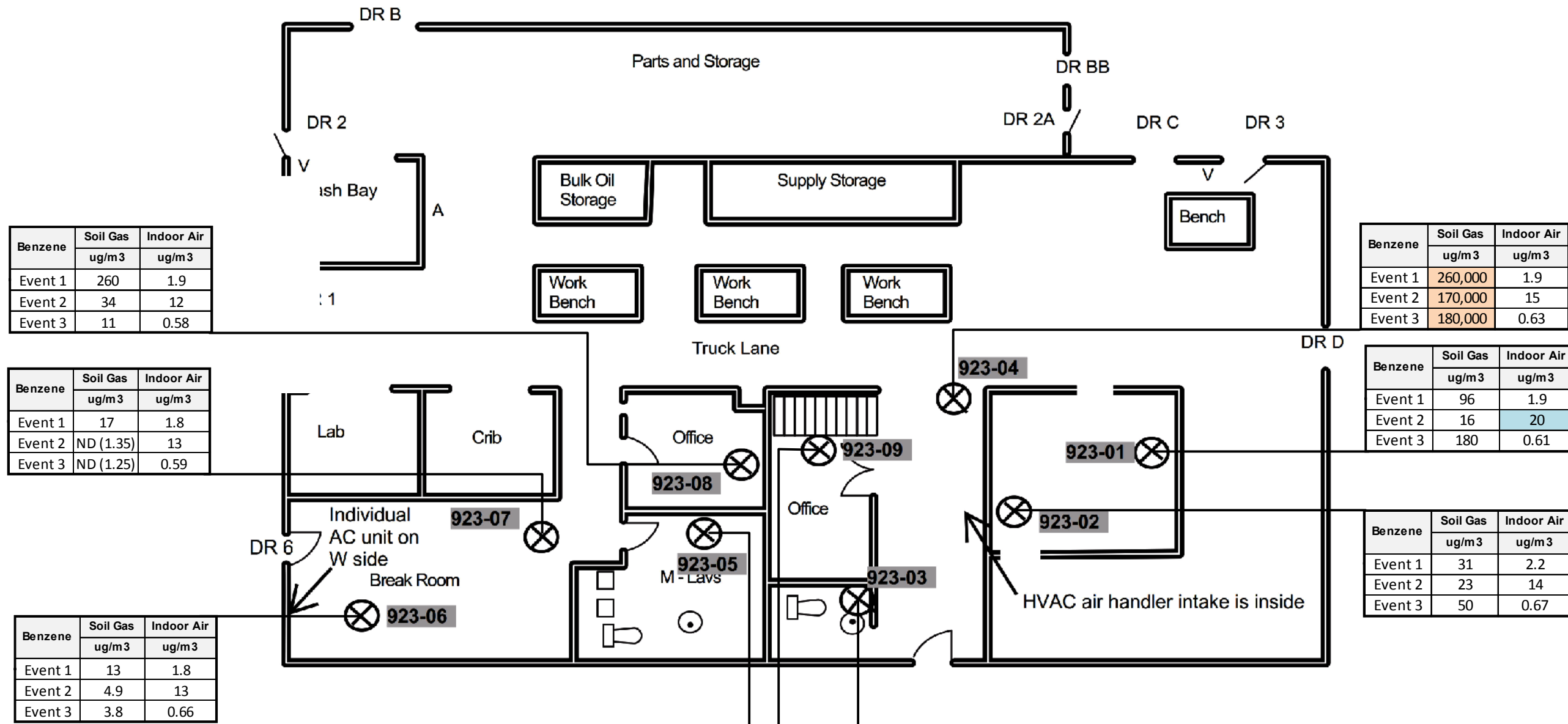

Benzene	Soil Gas	Indoor Air
	ug/m ³	ug/m ³
Event 1	260	1.9
Event 2	34	12
Event 3	11	0.58

Benzene	Soil Gas	Indoor Air
	ug/m ³	ug/m ³
Event 1	17	1.8
Event 2	ND (1.35)	13
Event 3	ND (1.25)	0.59

Benzene	Soil Gas	Indoor Air
	ug/m ³	ug/m ³
Event 1	13	1.8
Event 2	4.9	13
Event 3	3.8	0.66

Benzene	Soil Gas	Indoor Air
	ug/m ³	ug/m ³
Event 1	260,000	1.9
Event 2	170,000	15
Event 3	180,000	0.63

Benzene	Soil Gas	Indoor Air
	ug/m ³	ug/m ³
Event 1	96	1.9
Event 2	16	20
Event 3	180	0.61

Benzene	Soil Gas	Indoor Air
	ug/m ³	ug/m ³
Event 1	31	2.2
Event 2	23	14
Event 3	50	0.67

Benzene	Soil Gas	Indoor Air
	ug/m ³	ug/m ³
Event 1	12	2.2
Event 2	4.5	11
Event 3	7.2	0.6

Benzene	Soil Gas	Indoor Air
	ug/m ³	ug/m ³
Event 1	12	2.1
Event 2	5.2	11
Event 3	6.9	0.95

Benzene	Soil Gas	Indoor Air
	ug/m ³	ug/m ³
Event 1	160,000	2
Event 2	77,000	14
Event 3	97,000	1.3

Legend

⊗ 923-## Sub-slab/Indoor Air Location

- Exceeds RIASL₁₂ Only
- Exceeds TSRIASL₁₂
- Exceeds Dow OEL

Media	COC	RIASL ₁₂	TSRIASL ₁₂	OEL
Soil Gas	Benzene	510	1,800	--
Indoor Air	Benzene	15.4	54	1,595

Notes:

All units ug/m³

Initial Sampling Event (1) = October 2017

Seasonal Confirmation Sampling Event 2 = March 2018

Seasonal Confirmation Sampling Event 3 = August 2018

Outdoor air location collected on W side of building near Door 6. Note another intake located on roof to SE of wash bay area, points NE.

Benzene	Outdoor Air Sample
	ug/m ³
Event 1	0.53
Event 2	0.45
Event 3	0.49

Sub-slab Soil Gas and Indoor Air Results for Benzene
Zone 2 Phase 1
Sampling Events 1 - 3
Building 923

5.4.8 Vapor Intrusion Evaluation for Building 935

Building 935 is located in the southeastern quadrant of the Midland facility and is known as the Former Contractor Maintenance Building (Figure 5.4.8-1). The large eastern garage area was built sometime between 1965 and 1982. A small office area containing a kitchen and locker rooms was built on the western side of the garage between 1982 and 1993. The 17,958 ft² building is a slab-on-grade structure with no basement or elevators. The office area on the west side of the building is a single-story, and the garage portion of the structure is approximately two stories high. On the eastern side of the garage structure is a small bathroom in the northeastern corner, and a conference room located in the loft space above a caged storage area. The garage has nine bay doors, with the doors on the east and west side appearing to be open 24 hours a day and the remaining opened to facilitate parking when necessary. The ground cover around the building is asphalt.

The office space area is heated via hot air circulation and cooled via central AC. The conference room on the east side of the garage has AC as well. An intake for the conference room exists on the east side of the building, whereas the intake for the western side of the building is on the one-story roof on the southeastern corner.

At the time of the survey, the building was not occupied, but was indicated by the interviewee to be re-occupied in the near future. By the time the initial sampling was complete in the fall of 2017, the building was occupied with roughly 5 to 7 occupants.

PID readings collected during the survey showed no detections of VOCs in the ambient air or from any drain features observed in the building.

DATA SUMMARY

Building 935 has undergone three seasonal confirmation sampling events. Seasonal confirmation sampling was conducted at Building 935 since results from the initial sampling event exceeded screening levels. The analytical results from each of the sampling events were compared to the June 22, 2018 EGLE draft project-specific 12-hour Soil Gas screening values and AACs (draft project-specific RIASL₁₂ and TSRIASL₁₂, if available).

Building 935	
Initial Sampling Event	Completed
E1	November 2017 (Fall)
Seasonal Sampling Event	Completed
E2	April 2019 (Spring)
E3	August 2019 (Summer)
E4	<i>Scheduled - Winter 2019</i>

For each sampling event, sub-slab soil gas samples were collected from nine locations from within the building. Indoor air samples were collected at nine locations corresponding to the soil gas sample locations, along with an outdoor air sample from the main air intake. The sampling locations are shown on Figure 5.4.8-2. Summary statistics and screening comparison results are presented for sub-slab soil gas on Table 5.4.8-A and indoor and outdoor air on Table 5.4.8-B. The analytical data is presented in Appendix A. Field sampling forms are provided in Appendix B.

The building survey completed before the initial sampling event can be found in Appendix D. Drains and other openings were screened with a PID and no soil gas entry points were identified. A chemical inventory was completed during the building survey and the chemicals found to be stored within the building are listed in the survey.

SUB-SLAB SOIL GAS RESULTS EVALUATION

Analytical results were evaluated based on methodologies presented in the 2018 Revised Vapor Intrusion Work Plan. The number of analytes detected above the sub-slab soil gas draft project-specific RIASL₁₂ or TSRIASL₁₂, if available, are discussed below by sampling event and shown on Table 935-1:

1. During the initial event (Fall 2017), one analyte, chloroform, was detected above the draft project-specific RIASL₁₂;
2. During the second event (Spring 2019), one analyte, chloroform, was detected above the draft project-specific RIASL₁₂; and
3. During the third event (Summer 2019), all results were less than screening levels.

Table 935-1. Summary of Sub-Slab Soil Gas Exceedances for Building 935

Analyte	Detection Frequency	Measured Range of Detects ($\mu\text{g}/\text{m}^3$)	% Detections > Screening Level	Screening Level* ($\mu\text{g}/\text{m}^3$)
Chloroform (1)	89%	12 - 410	22%	170
Chloroform (2)	78%	8 - 290	11%	170
Chloroform (3)	67%	6.4 - 80	0%	170

*Screening level provided is the draft project-specific RIASL₁₂.

EVALUATION OF VAPOR INTRUSION

Table 935-2 summarizes the indoor air results relative to the sub-slab soil gas exceedances, since VI only potentially occurs if the analyte is present in both sub-slab soil gas and indoor air. Therefore, the table below provides the analytes detected above applicable screening levels in sub-slab soil gas as well as the corresponding indoor air sample results. The outdoor air sample results are also provided to determine if the analytes were present in indoor air due to migration from outdoor air.

Table 935-2. Vapor Intrusion Evaluation for Building 935

Analyte	Indoor Air Detection Frequency	Indoor Air Measured Range ($\mu\text{g}/\text{m}^3$)	Indoor Air Screening Level* ($\mu\text{g}/\text{m}^3$)	Outdoor Air Result ($\mu\text{g}/\text{m}^3$)
Chloroform (1)	100%	0.20 - 0.44	5.2	<0.17
Chloroform (2)	100%	0.63 - 0.99	5.2	0.16
Chloroform (3)**	--	--	--	--

*Screening level provided is the draft project-specific RIASL₁₂.

**Indoor and outdoor air samples were inadvertently not collected at Building 935 during E3.

All indoor air results in E1 and E2 were less than screening levels. Chloroform results exceed screening levels in sub-slab soil gas in E1 and E2; however, detected concentrations of chloroform in indoor air in E1 and E2 were less than screening levels. While chloroform was detected in sub-slab soil gas in E3, it did not exceed screening levels. As noted above, indoor and outdoor air samples were inadvertently not collected during E3. If the results in E4 are consistent with results in E1 through E3 in sub-slab soil gas and indoor air results in E1 and E2, seasonal sampling will be considered complete. If the results in E4 are inconsistent with the E1 through E3 results, an additional event will be conducted prior to the completion of seasonal confirmation sampling. The maximum result of chloroform detected in indoor air at Building 935 was $0.99 \mu\text{g}/\text{m}^3$, which is < 1% of the Dow OEL. A full ND evaluation will be performed upon the completion of seasonal confirmation sampling in the 2020 CAIP.

CONCLUSIONS AND RECOMMENDATIONS

Based on the indoor air results, the VI pathway at Building 935 is an insignificant exposure pathway based on current use. However, based on the sub-slab soil gas results and given the potential for future VI, Building 935 has been placed in VI Path Forward Building Group 2, as lines of evidence indicate that VI is insignificant and all indoor air results are less than screening levels. The final seasonal confirmation sampling event is scheduled for Winter 2019 (E4); however, if results of E4 are inconsistent with previous events, an additional event will be completed prior to the completion of seasonal confirmation sampling. A full evaluation will be presented in the 2020 CAIP.

5.5 Zone 3 Phase 1 Buildings

As discussed in Section 5.1, the Dow facility has approximately 700 existing buildings and structures on-site; therefore, VI at the facility is being evaluated in a phased approach during the corrective action implementation effort. In 2018, initial evaluation activities were conducted for Zone 3 (Figure 5-1). Zone 3 covers approximately 390 acres and is generally located along the northern perimeter of the facility.

There are 214 structures identified within Zone 3. Each one has been preliminarily evaluated and categorized for a determination of further evaluation during the initial Zone 3 assessment activities. Of these 214 buildings, 47 have been classified as Category 1 or 2, requiring sampling to be completed during the initial Zone 3 evaluation. Due to the quantity of buildings, Zone 3 was divided into phases.

The 2018 Revised VI Work Plan included the sampling plans for priority buildings in Zone 3 that were initially referred to as Zone 3 Phase 1. As stated in the September 26, 2018 email to EGLE, only nine Zone 3 buildings were sampled in the fall of 2018 and are identified as Zone 3 Phase 1. The additional Zone 3 buildings presented in the workplan were reprioritized so that Dow could focus on additional investigations for priority buildings in Zones 1 and 2. The remainder of the buildings initially identified as Zone 3 Phase 1 became Zone 3 Phase 2 and were sampled in Fall 2019 (see Section 5.6). Results from the September 2019 sampling efforts will be communicated to EGLE during a monthly Corrective Action meeting in early 2020, unless results warrant notification and expedited reporting. All remaining priority buildings identified in Zone 3 will be Zone 3 Phase 3 and are currently scheduled for sampling in Fall 2020 (see Section 5.7).

The Zone 3 Phase 1 buildings were initially evaluated in the 2018 CAIP. Buildings that required seasonal confirmation sampling are evaluated within this section. The Zone 3 Phase 1 priority building surveys are included in Appendix D and include the survey, floorplan, chemical inventory, and PID readings. Zone 3 Phase 1 sampling results are evaluated for the buildings listed below in the following subsections:

- Section 5.5.1 Building 800;
- Section 5.5.2 Building 887;
- Section 5.5.3 Building 954;
- Section 5.5.4 Building 1038;
- Section 5.5.5 Building 1131;
- Section 5.5.6 Building 100;
- Section 5.5.7 Building 564;
- Section 5.5.8 Building 881;
- Section 5.5.9 Building 1037; and
- Section 5.5.10 Building 1042.

5.5.1 Vapor Intrusion Evaluation for Building 800

BACKGROUND

Building 800 is a Category 1 building that was constructed in the 1970s and is located in the northwestern quadrant of the Midland facility (Figure 5.5.1-1). This building contains office space, conference rooms,

bathrooms, and a control room for the Dow Automotive Glass Bonding process area in Building 100. The building is slab-on-grade construction with no elevator or basement and has a footprint of approximately 6,000 ft².

The building's heat is produced by steam radiation, and the air is cooled via a central AC system consisting of two chillers. There are two intakes on the building: one is located near the northwest corner of the building at ground level, and the other is located on the roof near the northwest corner. No bay doors/overhead doors exist on this structure. Approximately 20-30 occupants work in Building 800. Some of these occupants work 12-hour shifts, seven days on, seven days off. The office personnel work 8-hour days Monday through Friday. Occupants use the washer/dryers in Building 881 located next door to the east and also use a contracted weekly laundry service. The ground cover outside the building is predominantly asphalt.

No PID detections were observed in the ambient air or from any drain-like features in the building at the time of the survey.

DATA SUMMARY

Building 800 was sampled in September 2018. The analytical results from each of the sampling events were compared to the June 22, 2018 MDEQ draft project-specific 12-hour Soil Gas screening values and AACs (draft project-specific RIASL₁₂ and TSRIASL₁₂, if available).

Building 800	
Initial Sampling Event	Completed
E1	September 2018 (Fall)

Sub-slab soil gas samples were collected from four locations from within the building. Indoor air samples were collected at four locations corresponding to the soil gas sample locations, along with an outdoor air sample from the main air intake. The sampling locations are shown on Figure 5.5.1-2. Summary statistics and screening comparison results are presented for sub-slab soil gas on Table 5.5.1-A and indoor and outdoor air on Table 5.5.1-B. The analytical data is presented in Appendix A. Field sampling forms are provided in Appendix B.

The building survey completed before the initial sampling event can be found in Appendix D. Drains and other openings were screened with a PID and no soil gas entry points were identified. A chemical inventory was completed during the building survey and the chemicals found to be stored within the building, each listed in the survey, primarily included degreasers, lubricants, sealants, spray paints, insecticides, bleach and various cleaners (included in Appendix D).

Based on the screened results, no indoor air analytes were detected above the TSRIASL₁₂ during any of the sampling events at Building 800. Therefore, no EBS was necessary.

SUB-SLAB SOIL GAS RESULTS EVALUATION

Analytical results were evaluated based on methodologies presented in the 2018 Revised Vapor Intrusion Work Plan. Forty-two of the 65 analytes were ND in each of the samples. Twenty-three analytes were detected in sub-slab soil gas but all detected results were below the sub-slab soil gas draft project-specific RIASL₁₂ and TSRIASL₁₂, if available.

VAPOR INTRUSION RESULTS EVALUATION

VI only potentially occurs if the analyte is present in both sub-slab soil gas and indoor air. There were no exceedances of the sub-slab soil gas screening levels. For the 17 analytes detected in indoor air, all results were below the draft project-specific indoor air RIASL₁₂ and TSRIASL₁₂, if available. Eight analytes were detected in the outdoor air sample collected immediately upwind of the building and each

of these eight analytes were detected in indoor air, which indicates the potential for the presence of detected analytes to be attributed to outdoor air.

ND RLs for EDB and HCBd exceed screening levels in both sub-slab soil gas and indoor air. EDB and HCBd require further investigation which will be conducted once the facility-wide priority buildings have been sampled and evaluated.

CONCLUSIONS AND RECOMMENDATIONS

Based on the sampling results, the VI pathway at Building 800 is an insignificant exposure pathway based on current use. Building 800 was placed into VI Path Forward Building Group 1 and no further VI evaluation is warranted at this time.

5.5.2 Vapor Intrusion Evaluation for Building 887

BACKGROUND

Building 887 was constructed in the 1970s and is located in the southwestern quadrant of the Midland facility (Figure 5.5.2-1). The building is a one-story structure of slab-on-grade construction with no basement or elevators and has a footprint of approximately 1,449 ft². This building contains lab space and a large switch room with a bathroom. The building is used as a lab where operators from Building 954 perform material testing.

The building's heat is produced via a small gas-powered furnace, and an AC unit is located on the roof. The building also contains some small space heaters and a lab hood. The intake for this building is located on the roof. No bay doors/overhead doors exist on this structure. The concrete flooring in the lab portion of the building is painted. The ground cover outside of the building is predominantly concrete or asphalt, with some patches of gravel located to the south, west, and east.

At peak use, approximately 3-5 workers from Building 954 use this building in short shifts of 1-3 hours. Occupants use a contracted laundry service to clean uniforms and work clothes; however, the occupants also use the washers and dryers that are available at Building 954.

No PID readings were detected in the ambient air or from drains in the building at the time of the survey.

EXPEDITED REPORTING

An EBS was provided in February 2019 based on the Fall 2018 sampling event and EGLE's request for expedited reporting if an indoor air result exceeds the TSRIASL₁₂. Email notifications were provided in January, July, and October 2019. Seasonal confirmation sampling has continued for both sub-slab soil gas and indoor air. Dow conducted further investigation activities at Building 887 in May, July, and October 2019 and results were presented to EGLE during the monthly Corrective Action Status meetings. A Summary of Investigative Findings documenting the further investigation activities was submitted to EGLE in October 2019 and is summarized below.

Further Investigation Activities

Based on the results from the initial sampling event (E1), further investigation activities were conducted for Building 887 and documented in the Summary of Investigative Findings (October 2019). The goals for the building-specific investigation for Building 887 were to gain an understanding of potential sources and distribution of chloroform concentrations. Appendix C presents the October 2019 Summary of Further Investigation Findings report.

While TCE was also measured by the Field GC, chloroform is the main AOI in Building 887. In May and July 2019, baseline samples were collected at the previous indoor air and sub-slab soil gas locations. All

baseline sample results in May were < 0.2 ppbv chloroform and in July, there were no detectable levels of chloroform; however, in May, a sample collected an inch above the drain (887-BRD) that contained 12 ppbv chloroform and 14 ppbv TCE. During the July event, a depressurization test was conducted on the drain. There were no detected concentrations of chloroform or TCE at the bathroom drain, even after conducting a depressurization test. During the October 2019 further investigation activities, the field GC team revisited Building 887 since there were recent rains and retested the drain but results continued to be below detection limits.

During the May investigation, weather conditions were very wet with significant rains. Radar estimates³ show that over two inches of rain fell in the area over the eight days prior to the May activities. For the July investigation, radar estimates showed < 0.25 inches of rain fell in the week prior to the July investigation (i.e., dry conditions). These weather conditions are a possible explanation for the significant difference in findings at this drain. Weather conditions and sampling results suggest that vapors from the bathroom drain occurred as a result of the heavy rain event and that elevated chloroform and TCE concentrations measured from the drain were likely not attributable to VI, and more likely originated from sewer gas. Furthermore, while the presence of TCE was detected in the bathroom drain sample, it has not been detected in indoor air at Building 887. The VI seasonal confirmation sampling results indicate that the TCE concentrations detected in the drain are not attributable to VI, as all sub-slab soil gas results are well below the sub-slab soil gas RIASL₁₂.

DATA SUMMARY

Building 887 has undergone three seasonal confirmation sampling events. Seasonal confirmation sampling was conducted at Building 887 since results from the initial sampling event exceeded screening levels. The analytical results from each of the sampling events were compared to the June 22, 2018 EGLE draft project-specific 12-hour Soil Gas screening values and AACs (draft project-specific RIASL₁₂ and TSRIASL₁₂, if available).

Building 887	
Initial Sampling Event	Completed
E1	September 2018 (Fall)
Seasonal Sampling Event	Completed
E2	April 2019 (Spring)
E3	August 2019 (Summer)
E4	<i>Scheduled - Winter 2019</i>

For each sampling event, sub-slab soil gas samples were collected from three locations from within the building. Indoor air samples were collected at three locations corresponding to the soil gas sample locations, along with an outdoor air sample from the main air intake. The sampling locations are shown on Figure 5.5.2-2. Summary statistics and screening comparison results are presented for sub-slab soil gas on Table 5.5.2-A and indoor and outdoor air on Table 5.5.2-B. Sub-slab soil gas and indoor air results for each sample location and sampling event is provided for chloroform on Figure 887-1. The analytical data is presented in Appendix A. Field sampling forms are provided in Appendix B.

The building survey completed before the initial sampling event can be found in Appendix D. Drains and other openings were screened with a PID and no soil gas entry points were identified. The chemical inventory performed during the building survey identified various potential indoor emission sources, including soap, air freshener, and various laboratory reagents (e.g., acetone, hydrochloric acid). The building has running water, which is a potential source of chloroform, but no specific consumer items containing chloroform were identified.

³ <https://water.weather.gov/precip/>

SUB-SLAB SOIL GAS RESULTS EVALUATION

Analytical results were evaluated based on methodologies presented in the 2018 Revised Vapor Intrusion Work Plan. The number of analytes detected above the sub-slab soil gas draft project-specific RIASL₁₂ or TSRIASL₁₂, if available, are discussed below by sampling event and shown on Table 887-1:

1. During the initial event (Fall 2018), two analytes, chloroform and HCBd, were detected above the draft project-specific RIASL₁₂, and the chloroform result also exceeded the TSRIASL₁₂;
2. During the second event (Spring 2019), one analyte, chloroform, was detected above the draft project-specific RIASL₁₂, and one sample result was detected above the TSRIASL₁₂; and
3. During the third event (Summer 2019), two analytes, chloroform and HCBd, were detected above the draft project-specific RIASL₁₂, and the chloroform result also exceeded the TSRIASL₁₂.

Table 887-1. Summary of Sub-Slab Soil Gas Exceedances for Building 887

Analyte (Sampling Event)	Detection Frequency	Measured Range of Detects (µg/m ³)	% Detections > Screening Level	Screening Level* (µg/m ³)
Chloroform (1)	100%	3,200 - 4,700	100%	170
Chloroform (2)	100%	100 - 1,700	67%	170
Chloroform (3)	100%	270 - 2,100	100%	170
Hexachlorobutadiene (1)	33%	470	0%	180
Hexachlorobutadiene (2)	0%	ND	0%	180
Hexachlorobutadiene (3)	33%	580	9%	180

*Screening level provided is the draft project-specific RIASL₁₂.

EVALUATION OF VAPOR INTRUSION

Table 887-2 summarizes the indoor air results relative to the sub-slab soil gas exceedances, since VI only potentially occurs if the analyte is present in both sub-slab soil gas and indoor air. Therefore, the table below provides the analytes detected above applicable screening levels in sub-slab soil gas as well as the corresponding indoor air sample results. The outdoor air sample results are also provided to determine if the analytes were present in indoor air due to migration from outdoor air.

Table 887-2. Vapor Intrusion Evaluation for Building 887

Analyte (Sampling Event)	Indoor Air Detection Frequency	Indoor Air Measured Range (µg/m ³)	Indoor Air Screening Level* (µg/m ³)	Outdoor Air Result (µg/m ³)
Chloroform (1)	100%	1.6 - 8.6	5.2	ND
Chloroform (2)	100%	0.23 - 0.43	5.2	ND
Chloroform (3)	100%	0.37 - 0.42	5.2	0.36
Hexachlorobutadiene (1)	0%	ND	5.4	ND
Hexachlorobutadiene (2)	0%	ND	5.4	ND
Hexachlorobutadiene (3)	0%	ND	5.4	ND

*Screening level provided is the draft project-specific RIASL₁₂.

Chloroform was the only analyte detected above a screening level in indoor air during any of the three sampling events. Sub-slab soil gas and indoor air results for chloroform by sample location are provided on Figure 5.5.2-2. Chloroform exceeded the RIASL₁₂ for indoor air during E1 at 887-IA-02. During subsequent sampling events, chloroform was 0.38 µg/m³ and 0.39 µg/m³ at that location, respectively, which are below the screening level. Results in sub-slab soil gas at that location have been inconsistent with an E1 detection of 3,200 µg/m³ above the TSRIASL₁₂, an E2 detection of 100 µg/m³ which is less

than the RIASL₁₂, and 1,600 µg/m³ detected in E3 (greater than the RIASL₁₂); however, indoor air decreased in E2 and E3. Furthermore, as this sample location is in the building's lab space, it is likely that the treated water used in the lab is contributing to the result. Chloroform is ubiquitous in indoor air and often found in soil gas samples. Chloroform is one of the trihalomethanes produced by chlorination of water supplies. It has long been known that chloroform and other VOCs in tap water can be emitted into indoor air (McKone, 1987). Sinks also may be significant sources (Howard and Corsi, 1998) (Howard and Corsi, 1996). The maximum result of chloroform detected in indoor air at Building 887 was 8.6 µg/m³, which is < 1% of the Dow OEL. A full ND evaluation will be performed upon the completion of seasonal confirmation sampling in the 2020 CAIP.

CONCLUSIONS AND RECOMMENDATIONS

Based on the indoor air results and further investigation findings, the VI pathway at Building 887 is an insignificant exposure pathway based on current use. However, based on the sub-slab soil gas results and given the potential for future VI, Building 887 has been placed in VI Path Forward Building Group 4A, as lines of evidence indicate that VI is insignificant and the single indoor air exceedance of chloroform was likely due to indoor sources, including the laboratory and potentially sewer gas from the bathroom drain during heavy rain events. The final seasonal confirmation sampling event is scheduled for Winter 2019 (December). A full evaluation will be presented in the 2020 CAIP.

Figure 887-1

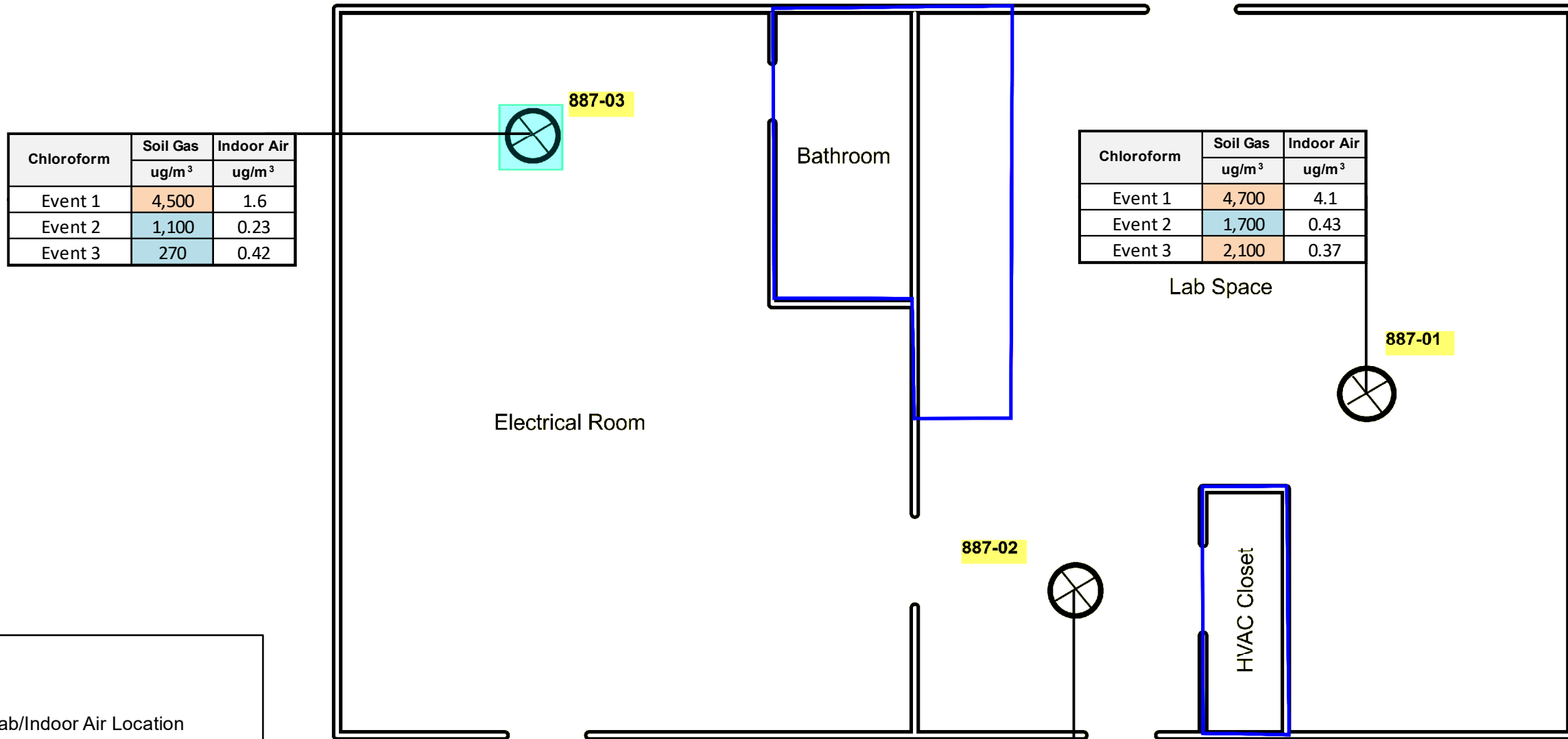

Chloroform	Soil Gas	Indoor Air
	ug/m ³	ug/m ³
Event 1	4,500	1.6
Event 2	1,100	0.23
Event 3	270	0.42

Chloroform	Soil Gas	Indoor Air
	ug/m ³	ug/m ³
Event 1	4,700	4.1
Event 2	1,700	0.43
Event 3	2,100	0.37

Chloroform	Soil Gas	Indoor Air
	ug/m ³	ug/m ³
Event 1	3,200	8.6
Event 2	100	0.38
Event 3	1,600	0.39

Legend

- 887-## Sub-slab/Indoor Air Location
- Preferential Pathways Observed (drains)
- Exceeds RIASL₁₂ Only
- Exceeds TSRIASL₁₂
- Exceeds Dow OEL

Media	COC	RIASL ₁₂	TSRIASL ₁₂	OEL
Soil Gas	Chloroform	170	1,700	--
Indoor Air	Chloroform	5.2	52	9,760

Notes:
 All units ug/m³
 Initial Sampling Event
 1 = September 2018
 Sampling Event
 2 = April 2019
 Sampling Event
 3 = August 2019
 Intake is located on roof.

Chloroform	Outdoor Air Sample
	ug/m ³
Event 1	ND (0.17)
Event 2	ND (0.15)
Event 3	0.36

Sub-slab Soil Gas and Indoor Air Results for Chloroform Zone 3 Phase 1 Sampling Event 1-3 Building 887

5.5.3 Vapor Intrusion Evaluation for Building 954

Building 954 was built in the 1970s and is located in the southwestern quadrant of the Midland facility (Figure 5.5.3-1). The building contains offices, a control room, permit writing room, kitchen/break room, locker rooms, a laundry area, and general personal protective equipment (PPE) storage area (also referred to as the “old shop area”). The building is a one-story structure of slab-on-grade construction with a footprint of approximately 9,560 ft². No bay doors/overhead doors exist on this structure, nor does this structure have an elevator or basement.

Building 954 is heated via hot air circulation and is cooled via two AC units. The building has two air intakes; one intake is located at ground level on the west side of the building, and one is located on the roof. The locker rooms have an epoxy coating on the floor, and the permit room and old shop area have paint on the concrete floors. Approximately 30 occupants work in Building 954. Some of these occupants work 8 to 12-hour shifts, over 24 hours 7 days a week. Office personnel work 8 to 12-hour shifts, 8 hours per day Monday through Friday, 12 hours per day over the weekend. The immediate area surrounding the building is predominantly covered by concrete or asphalt, with the exception of some gravel to the north of the building along the railroad tracks.

PID detections from 0.1-0.4 parts per million (ppm) were observed in the ambient air throughout the hallway outside the control room, the ambient air in the locker rooms, the janitor’s closet, the safe work permit area, and old shop area.

DATA SUMMARY

Building 954 was sampled in September 2018. The analytical results from each of the sampling events were compared to the June 22, 2018 MDEQ draft project-specific 12-hour Soil Gas screening values and AACs (draft project-specific RIASL₁₂ and TSRIASL₁₂, if available).

Building 954	
Initial Sampling Event	Completed
E1	September 2018 (Fall)

Sub-slab soil gas samples were collected from seven locations from within the building. Indoor air samples were collected at seven locations corresponding to the soil gas sample locations, along with an outdoor air sample from the main air intake. The sampling locations are shown on Figure 5.5.3-2. Summary statistics and screening comparison results are presented for sub-slab soil gas on Table 5.5.3-A and indoor and outdoor air on Table 5.5.3-B. The analytical data is presented in Appendix A. Field sampling forms are provided in Appendix B.

The building survey completed before the initial sampling event can be found in Appendix D. Drains and other openings were screened with a PID and no soil gas entry points were identified. A chemical inventory was completed during the building survey and the chemicals found to be stored within the building, each listed in the survey, primarily included degreasers, spray paints, bleach and various cleaners (included in Appendix D).

Based on the screened results, no indoor air analytes were detected above the TSRIASL₁₂ during any of the sampling events at Building 954. Therefore, no EBS was necessary.

SUB-SLAB SOIL GAS RESULTS EVALUATION

Analytical results were evaluated based on methodologies presented in the 2018 Revised Vapor Intrusion Work Plan. Thirty-seven of the 65 analytes were ND in each of the samples. Twenty-eight analytes were detected in sub-slab soil gas but all detected results were below the sub-slab soil gas draft project-specific RIASL₁₂ and TSRIASL₁₂, if available.

VAPOR INTRUSION RESULTS EVALUATION

VI only potentially occurs if the analyte is present in both sub-slab soil gas and indoor air. There were no exceedances of the sub-slab soil gas screening levels. For the 31 analytes detected in indoor air, all results were below the draft project-specific indoor air RIASL₁₂ and TSRIASL₁₂, if available. Nine analytes were detected in the outdoor air sample collected immediately upwind of the building and each of these nine analytes were detected in indoor air, which indicates the potential for the presence of detected analytes to be attributed to outdoor air.

ND RLs for EDB (indoor air and sub-slab soil gas), HCBd (indoor air only) and 1,1,2-TCA (sub-slab soil gas only) exceed screening levels. EDB and HCBd require further investigation which will be conducted once the facility-wide priority buildings have been sampled and evaluated. The ND RL for 1,1,2-TCA in sub-slab soil gas only exceeded at one sample location and the ND RL was < 21 µg/m³ compared to the 12-hour soil gas screening level of 20 µg/m³.

CONCLUSIONS AND RECOMMENDATIONS

Based on the sampling results, the VI pathway at Building 954 is an insignificant exposure pathway based on current use. Building 954 was placed into VI Path Forward Building Group 1 and no further VI evaluation is warranted at this time.

5.5.4 Vapor Intrusion Evaluation for Building 1038

Building 1038 was built in the 1970s and is located in the southwestern quadrant of the Midland facility (Figure 5.5.4-1). This building is primarily used for storage and is “unoccupied” according to the building contacts; however, the building appears to have some level of consistent occupancy and has office areas, a library, bathrooms, a large break area, and an old lab space being used as storage. It appears the building is used as additional work/break areas for the occupants in Building 1037, which is located next door to the east. The building is a one-story structure of slab-on-grade construction with no basement or elevator and has a footprint of approximately 3,235 ft².

The building is heated via steam radiation, and a central AC unit is associated with an air handler located in the southern mechanical room. The outdoor intake is located on the southern side of the building just outside of the southern mechanical room. This building has no overhead/bay doors and the surrounding outdoor ground cover is either asphalt or gravel. Approximately 10-15 occupants work an 8-hour day shift during the week and rarely work weekend hours. Occupants from Building 1037 also use this space.

No PID detections were observed in the ambient air throughout the building, and no PID readings were detected from any drain features noted at the time of the survey.

DATA SUMMARY

Building 1038 has undergone three seasonal confirmation sampling events. Seasonal confirmation sampling was conducted at Building 1038 since results from the initial sampling event exceeded screening levels. The analytical results from each of the sampling events were compared to the June 22, 2018 EGLE draft project-specific 12-hour Soil Gas screening values and AACs (draft project-specific RIASL₁₂ and TSRIASL₁₂, if available).

Building 1038	
Initial Sampling Event	Completed
E1	September 2018 (Fall)
Seasonal Sampling Event	Completed
E2	April 2019 (Spring)
E3	August 2019 (Summer)
E4	<i>Scheduled - Winter 2019</i>

For each sampling event, sub-slab soil gas samples were collected from three locations from within the building. Indoor air samples were collected at three locations corresponding to the soil gas sample locations, along with an outdoor air sample from the main air intake. The sampling locations are shown on Figure 5.5.4-2. Summary statistics and screening comparison results are presented for sub-slab soil gas on Table 5.5.4-A and indoor and outdoor air on Table 5.5.4-B. The analytical data is presented in Appendix A. Field sampling forms are provided in Appendix B.

The building survey completed before the initial sampling event can be found in Appendix D. Drains and other openings were screened with a PID and no soil gas entry points were identified. A chemical inventory was completed during the building survey and the chemicals found to be stored within the building are listed in the survey.

SUB-SLAB SOIL GAS RESULTS EVALUATION

Analytical results were evaluated based on methodologies presented in the 2018 Revised Vapor Intrusion Work Plan. The number of analytes detected above the sub-slab soil gas draft project-specific RIASL₁₂ or TSRIASL₁₂, if available, are discussed below by sampling event and shown on Table 1038-1:

4. During the initial event (Fall 2018), two analytes were detected above the draft project-specific RIASL₁₂ (1,3-DCB and 1,4-DCB);
5. During the second event (Spring 2019), all results were below screening levels; and
6. During the third event (Summer 2019), only 1,4-DCB was detected above the draft project-specific RIASL₁₂.

Table 1038-1. Summary of Sub-Slab Soil Gas Exceedances for Building 1038

Analyte (Sampling Event)	Detection Frequency	Measured Range of Detects ($\mu\text{g}/\text{m}^3$)	% Detections > Screening Level	Screening Level* ($\mu\text{g}/\text{m}^3$)
1,3-Dichlorobenzene (1)	100%	95 - 420	67%	310
1,3-Dichlorobenzene (2)	100%	11 - 190	0%	310
1,3-Dichlorobenzene (3)	100%	16 - 98	0%	310
1,4-Dichlorobenzene (1)	100%	600 - 6,200	67%	1,000
1,4-Dichlorobenzene (2)	67%	40 - 1,000	0%	1,000
1,4-Dichlorobenzene (3)	67%	86 - 1,300	33%	1,000

*Screening level provided is the draft project-specific RIASL₁₂.

EVALUATION OF VAPOR INTRUSION

Table 1038-2 summarizes the indoor air results relative to the sub-slab soil gas exceedances, since VI only potentially occurs if the analyte is present in both sub-slab soil gas and indoor air. Therefore, the table below provides the analytes detected above applicable screening levels in sub-slab soil gas as well as the corresponding indoor air sample results. The outdoor air sample results are also provided to determine if the analytes were present in indoor air due to migration from outdoor air.

Table 1038-2. Vapor Intrusion Evaluation for Building 1038

Analyte (Sampling Event)	Indoor Air Detection Frequency	Indoor Air Measured Range ($\mu\text{g}/\text{m}^3$)	Indoor Air Screening Level* ($\mu\text{g}/\text{m}^3$)	Outdoor Air Result ($\mu\text{g}/\text{m}^3$)
1,3-Dichlorobenzene (1)	0%	ND	9.2	ND
1,3-Dichlorobenzene (2)	0%	ND	9.2	ND
1,3-Dichlorobenzene (3)	0%	ND	9.2	ND
1,4-Dichlorobenzene (1)	0%	ND	30	ND
1,4-Dichlorobenzene (2)	67%	0.25 - 0.26	30	0.26
1,4-Dichlorobenzene (3)	33%	0.38	30	ND

*Screening level provided is the draft project-specific RIASL₁₂.

While concentrations of 1,3-DCB and 1,4-DCB in some of the sampling events were detected above the draft project-specific RIASL₁₂ in sub-slab soil gas, only 1,4-DCB was detected in indoor air. 1,4-DCB was detected in indoor air in E2 and E3 but the detections were below the screening level. . The maximum result of 1,4-DCB detected in indoor air at Building 1038 was 0.26 $\mu\text{g}/\text{m}^3$, which is < 1% of the Dow OEL. A full ND evaluation will be performed upon the completion of seasonal confirmation sampling in the 2020 CAIP.

CONCLUSIONS AND RECOMMENDATIONS

Based on the indoor air results, the VI pathway at Building 1038 is an insignificant exposure pathway based on current use. However, based on the sub-slab soil gas results and given the potential for future VI, Building 1038 has been placed in VI Path Forward Building Group 2, as lines of evidence indicate that VI is insignificant and all indoor air results are less than screening levels. The final seasonal confirmation sampling event is scheduled for Winter 2019 (December). A full evaluation will be presented in the 2020 CAIP.

5.5.5 Vapor Intrusion Evaluation for Building 1131

Building 1131 was constructed in the early 1980s and is located in the northeastern quadrant of the Midland facility (Figure-5.5.5-1). This building contains office space, conference rooms, locker rooms, a kitchen/break room, a control room, a safe work permit writer room, a shop/laundry area, and a product lab. The building is a one-story structure of slab-on-grade construction with no basement or elevator and has a footprint of 14,913 ft².

The building is heated by hot air circulation and is cooled via four AC units located around the building. Outside air intakes are associated with all four AC units, which are located on the north side of the building, the northwestern corner of the building, the southeastern corner of the building, and the south side of the building. One bay door exists on the west side of the building near the northwestern corner of the shop area and is open for roughly two thirds of the year. This bay door does allow for gas/diesel-powered vehicles and equipment to be pulled into the building. The outdoor ground cover surrounding the building is asphalt. There are approximately 35 occupants in Building 1131. The office personnel work 8-hour days Monday through Friday. Other occupants work 8-hour shifts, 24 hours a day. Although washers and dryers are present in the building, some occupants use a contracted laundry service twice a week.

No PID detections were observed in the ambient air throughout the building or from any drain-like features noted at the time of the survey.

DATA SUMMARY

Building 1131 was sampled in September 2018. The analytical results from each of the sampling events were compared to the June 22, 2018 MDEQ draft project-specific 12-hour Soil Gas screening values and AACs (draft project-specific RIASL₁₂ and TSRIASL₁₂, if available).

Building 1131	
Initial Sampling Event	Completed
E1	September 2018 (Fall)

Sub-slab soil gas samples were collected from nine locations from within the building. Indoor air samples were collected at nine locations corresponding to the soil gas sample locations, along with an outdoor air sample from the main air intake. The sampling locations are shown on Figure 5.5.5-2. Summary statistics and screening comparison results are presented for sub-slab soil gas on Table 5.5.5-A and indoor and outdoor air on Table 5.5.5-B. The analytical data is presented in Appendix A. Field sampling forms are provided in Appendix B.

The building survey completed before the initial sampling event can be found in Appendix D. Drains and other openings were screened with a PID and no soil gas entry points were identified. A chemical inventory was completed during the building survey and the chemicals found to be stored within the building, each listed in the survey, primarily included degreasers, lubricants, adhesive sprays, spray paints, bleach, and various cleaners (included in Appendix A).

Based on the screened results, no indoor air analytes were detected above the TSRIASL₁₂ during any of the sampling events at Building 1131. Therefore, no EBS was necessary.

SUB-SLAB SOIL GAS RESULTS EVALUATION

Analytical results were evaluated based on methodologies presented in the 2018 Revised Vapor Intrusion Work Plan. Forty-one of the 65 analytes were ND in each of the samples. Twenty-four analytes were detected in sub-slab soil gas but all detected results were below the sub-slab soil gas draft project-specific RIASL₁₂ and TSRIASL₁₂, if available.

VAPOR INTRUSION RESULTS EVALUATION

VI only potentially occurs if the analyte is present in both sub-slab soil gas and indoor air. There were no exceedances of the sub-slab soil gas screening levels. For the 27 analytes detected in indoor air, all results were below the draft project-specific indoor air RIASL₁₂ and TSRIASL₁₂, if available. Fifteen analytes were detected in the outdoor air sample collected immediately upwind of the building and 14 of the 15 analytes were detected in indoor air, which indicates the potential for the presence of detected analytes to be attributed to outdoor air.

ND RLs for EDB (indoor air and sub-slab soil gas), HCBd (indoor air only), and 1,2,4-TCB (indoor air only) exceed screening levels in both sub-slab soil gas and indoor air. EDB and HCBd require further investigation which will be conducted once the facility-wide priority buildings have been sampled and evaluated. Only two ND RLs exceeded the screening level for 1,2,4-TCB.

CONCLUSIONS AND RECOMMENDATIONS

Based on the sampling results, the VI pathway at Building 1131 is an insignificant exposure pathway based on current use. Building 1131 was placed into VI Path Forward Building Group 1 and no further VI evaluation is warranted at this time.

5.5.6 Vapor Intrusion Evaluation for Building 100

BACKGROUND

Building 100 was constructed 13 years ago, is located in the northwestern quadrant of the Midland facility and has a footprint of approximately 64,155 ft² (Figure 5.5.6-1). This building contains office space in its southeastern corner/annex portion, a warehouse, and large process area. Roughly 38,796 ft² of the footprint is process area that ranges from being fully enclosed to open-air. The warehouse, office area, and a portion of the process area are slab-on-grade construction with no basements or elevators. The office portion of the structure is one-story and the warehouse structure is roughly two to three stories tall.

The warehouse is heated via steam radiation and the office area is heated by hot air circulation. The office area is cooled by a central AC system. An outside intake for the office area is located on the north side of the office annex and an intake for the warehouse is located on the roof and points northward. The warehouse portion of the structure has 16 bay doors, four of which are open frequently for shipping purposes, but are typically open for a short period of time. However, during the summer months these bay doors are left open more frequently. The surrounding ground cover outside the building consists of primarily concrete and asphalt. Propane-fueled forklifts are used in the warehouse area. There are approximately 25-30 occupants working in Building 100 and some work a 12-hour day shift 7 days a week but office personnel work 8 hours per day Monday through Friday. Occupants either use a contracted weekly laundry service or use the washers and dryers located in Building 881.

During the survey, no PID detections were observed in the ambient air throughout the office area or warehouse, but PID detections from drains found in the janitor's closet, women's bathroom, and men's bathroom ranged from 13.2 ppm to 520.1 ppm. The higher PID readings detected from drain features are believed to be false positive readings. False positive readings on a PID may occur in the presence of excess water vapor. High humidity can cause lamp fogging and decreased sensitivity. This can be significant when moisture levels are high in the general area to be measured.

DATA SUMMARY

Building 100 has undergone three seasonal confirmation sampling events. Seasonal confirmation sampling was conducted at Building 100 since results from the initial sampling event exceeded screening levels. The analytical results from each of the sampling events were compared to the June 22, 2018 EGLE draft project-specific 12-hour Soil Gas screening values and AACs (draft project-specific RIASL₁₂ and TSRIASL₁₂, if available).

Building 100	
Initial Sampling Event	Completed
E1	September 2018 (Fall)
Seasonal Sampling Event	Completed
E2	April 2019 (Spring)
E3	August 2019 (Summer)
E4	<i>Scheduled - Winter 2019</i>

For each sampling event, sub-slab soil gas samples were collected from 11 locations from within the building. Indoor air samples were collected at 11 locations corresponding to the soil gas sample locations, along with an outdoor air sample from the main air intake. The sampling locations are shown on Figure 5.5.6-2. Summary statistics and screening comparison results are presented for sub-slab soil gas on Table 5.5.6-A and indoor and outdoor air on Table 5.5.6-B. The analytical data is presented in Appendix A. Field sampling forms are provided in Appendix B.

The building survey completed before the initial sampling event can be found in Appendix D. Drains and other openings were screened with a PID and no soil gas entry points were identified. A chemical

inventory was completed during the building survey and the chemicals found to be stored within the building are listed in the survey.

SUB-SLAB SOIL GAS RESULTS EVALUATION

Analytical results were evaluated based on methodologies presented in the 2018 Revised Vapor Intrusion Work Plan. The number of analytes detected above the sub-slab soil gas draft project-specific RIASL₁₂ or TSRIASL₁₂, if available, are discussed below by sampling event and shown on Table 100-1:

1. During the initial event (Fall 2018), seven analytes were detected above the draft project-specific RIASL₁₂ including chloroform, cis-1,2-DCE, trans-1,2-DCE, PCE, and TCE, which were also detected above the TSRIASL₁₂;
2. During the second event (Spring 2018), seven analytes were detected above the draft project-specific RIASL₁₂ including PCE and TCE, which were also detected above the TSRIASL₁₂; and
3. During the third event (Summer 2018), eight analytes were detected above the draft project-specific RIASL₁₂ including chloroform, cis-1,2-DCE, PCE, and TCE, which were also detected above the TSRIASL₁₂.

Table 100-1. Summary of Sub-Slab Soil Gas Exceedances for Building 100

Analyte (Sampling Event)	Detection Frequency	Measured Range of Detects ($\mu\text{g}/\text{m}^3$)	% Detections > Screening Level	Screening Level* ($\mu\text{g}/\text{m}^3$)
1,2-Dichloropropane (1)	100%	6.4 - 1,800	36%	410
1,2-Dichloropropane (2)	91%	14 - 860	27%	410
1,2-Dichloropropane (3)	91%	16 - 1,200	18%	410
Chloroform (1)	100%	14 - 2,200	55%	170
Chloroform (2)	91%	32 - 1,900	64%	170
Chloroform (3)	91%	18 - 2,600	36%	170
cis-1,2-Dichloroethene (1)	100%	5.3 - 8,500	45%	820
cis-1,2-Dichloroethene (2)	91%	86 - 1,600	36%	820
cis-1,2-Dichloroethene (3)	91%	48 - 3,400	36%	820
Hexachlorobutadiene (1)	45%	160 - 830	36%	180
Hexachlorobutadiene (2)	36%	240 - 610	36%	180
Hexachlorobutadiene (3)	73%	210 - 1,700	73%	180
PCE (1)	100%	300 - 240,000	73%	2,700
PCE (2)	100%	59 - 120,000	82%	2,700
PCE (3)	100%	30 - 170,000	55%	2,700
trans-1,2-Dichloroethene (1)	100%	4.2 - 31,000	18%	8,200
trans-1,2-Dichloroethene (2)	91%	37 - 13,000	9%	8,200
trans-1,2-Dichloroethene (3)	91%	12 - 19,000	18%	8,200
TCE (1)	100%	40 - 23,000	82%	130
TCE (2)	100%	7.6 - 9,700	91%	130
TCE (3)	91%	240 - 17,000	91%	130

*Screening level provided is the draft project-specific RIASL₁₂.

EVALUATION OF VAPOR INTRUSION

Table 100-2 summarizes the indoor air results relative to the sub-slab soil gas exceedances, since VI only potentially occurs if the analyte is present in both sub-slab soil gas and indoor air. Therefore, the table below provides the analytes detected above applicable screening levels in sub-slab soil gas as well as the corresponding indoor air sample results. The outdoor air sample results are also provided to determine if the analytes were present in indoor air due to migration from outdoor air.

Table 100-2. Vapor Intrusion Evaluation for Building 100

Analyte (Sampling Event)	Indoor Air Detection Frequency	Indoor Air Measured Range ($\mu\text{g}/\text{m}^3$)	Indoor Air Screening Level* ($\mu\text{g}/\text{m}^3$)	Outdoor Air Result ($\mu\text{g}/\text{m}^3$)
1,2-Dichloropropane (1)	0%	ND	12.2	ND
1,2-Dichloropropane (2)	0%	ND	12.2	ND
1,2-Dichloropropane (3)	0%	ND	12.2	ND
Chloroform (1)	100%	0.43 - 1.8	5.2	ND
Chloroform (2)	73%	0.22 - 1.5	5.2	ND
Chloroform (3)	73%	0.17 - 3.1	5.2	ND
cis-1,2-Dichloroethene (1)	36%	0.15 - 0.21	24	ND
cis-1,2-Dichloroethene (2)	9%	0.25	24	ND
cis-1,2-Dichloroethene (3)	9%	0.16	24	ND
Hexachlorobutadiene (1)	0%	ND	5.4	ND
Hexachlorobutadiene (2)	0%	ND	5.4	ND
Hexachlorobutadiene (3)	0%	ND	5.4	ND
PCE (1)	100%	0.54 - 5.8	82	ND
PCE (2)	100%	0.59 - 8.1	82	ND
PCE (3)	100%	0.63 - 4.1	82	0.88
trans-1,2-Dichloroethene (1)	0%	ND	240	ND
trans-1,2-Dichloroethene (2)	0%	ND	240	ND
trans-1,2-Dichloroethene (3)	0%	ND	240	ND
TCE (1)	36%	0.96 - 1.1	4	ND
TCE (2)	55%	0.22 - 1.5	4	ND
TCE (3)	64%	0.17 - 0.84	4	ND

*Screening level provided is the draft project-specific RIASL12.

A full ND evaluation will be performed upon the completion of seasonal confirmation sampling in the 2020 CAIP.

CONCLUSIONS AND RECOMMENDATIONS

Based on the indoor air results, the VI pathway at Building 100 is an insignificant exposure pathway based on current use. However, based on the sub-slab soil gas results and given the potential for future VI, Building 100 has been placed in VI Path Forward Building Group 2, as lines of evidence indicate that VI is insignificant and all indoor air results are less than screening levels. The final seasonal confirmation sampling event is scheduled for Winter 2019. A full evaluation will be presented in the 2020 CAIP.

5.5.7 VI Seasonal Confirmation Sampling Results Evaluation for Building 564

INTRODUCTION

Building 564 is a Category 2 building located within the northern portion of the facility designated as Zone 3 and is known as the Saran Building (Figure 5.5.7-1). The initial evaluation concluded that the TCE detected in the indoor air at Building 564 is due to indoor sources and not attributable to VI. The indoor air results suggest a common source, such as work within the shop and spare parts area in the northwest corner of the building involving degreasers or other products. Building 564 was placed in VI Path Forward Building Group 4A. Group 4A is a designation for buildings that have sub-slab soil gas and indoor air exceedances that indicate there is a lack of correlated sample exceedances and other lines of evidence indicate that VI is insignificant and IA exceedances are likely due to routine workplace chemical use. Interim response actions are not necessary to address the detections of TCE. Seasonal confirmation sampling was conducted.

In December 2017, sampling activities were completed for Building 564 as part of a Baseline Environmental Assessment (BEA) (AECOM, January 2018). An Expedited Building Summary was

provided for Building 564 on August 24, 2018 based on sampling results from December 2017. Seasonal confirmation sampling has continued for both sub-slab soil gas and indoor air. Email notifications were provided in January and July 2019 based on the results of the Fall 2018 and Spring 2019 seasonal confirmation sampling events. A Summary of Investigative Findings documenting the further investigation activities that took place in May 2019 at Buildings 499, 564 and 827 was also provided to EGLE on July 19, 2019. The overall lack of correlation between the sub-slab soil gas and indoor air results continue to suggest VI is not the main source of indoor air detections.

Building 564 has undergone four seasonal confirmation sampling events. Seasonal confirmation sampling was conducted at Building 564 since results from the initial sampling event exceeded screening levels. The analytical results from each of the sampling events were compared to the June 22, 2018 MDEQ draft project-specific 12-hour Soil Gas screening values and AACs (draft project-specific RIASL₁₂ and TSRIASL₁₂, if available).

The results of the initial sampling event (E1) were evaluated in Section 5.4.3 of the 2018 CAIP. Since that time, three additional seasonal events were completed and the results of all completed seasonal events are included in this evaluation.

Building 564	
Initial Sampling Event	Completed
E1	December 2017 (Winter)
E2	November 2018 (Fall)
E3	April 2019 (Spring)
E4	August 2019 (Summer)

Based on the evaluation of the four seasonal confirmation sampling events, the VI pathway continues to be insignificant. Sufficient information exists to make a human exposure under control EI determination.

SUB-SLAB SOIL GAS RESULTS EVALUATION

Sub-slab soil gas samples were collected from 49 locations from within the building. Indoor air samples were collected at 49 locations corresponding to the soil gas sample locations, along with an outdoor air sample from the main air intake. The sampling locations are shown on Figure 5.5.7-2. Summary statistics and screening comparison results are presented for sub-slab soil gas on Table 5.5.7-A and indoor and outdoor air on Table 5.5.7-B. The analytical data is presented in Appendix A. Field sampling forms are provided in Appendix B. A figure showing results for each sample location per event is provided for TCE since it has exceedances in both sub-slab soil gas and indoor air (Figure 564-1). Table 564-1 presents the sub-slab soil gas results from seasonal confirmation sampling that exceed the draft project-specific screening levels.

Table 564-1. Summary of Sub-Slab Soil Gas Exceedances for Building 564

Analyte	Detection Frequency	Measured Range of Detects ($\mu\text{g}/\text{m}^3$)	% Detections > Screening Level	Screening Level* ($\mu\text{g}/\text{m}^3$)
Tetrachloroethene (1)	96%	5.5 - 12,000	6%	2,700
Tetrachloroethene (2)	94%	6.4 - 14,000	4%	2,700
Tetrachloroethene (3)	100%	10 - 8,000	13%	2,700
Tetrachloroethene (4)	100%	8.3 - 9,800	13%	2,700
Trichloroethene (1)	29%	5.1 - 140	2%	130
Trichloroethene (2)	39%	4.5 - 190	2%	130
Trichloroethene (3)	60%	4.9 - 110	0%	130
Trichloroethene (4)	47%	7.1 - 260	7%	130

*Screening level provided is the draft project-specific RIASL₁₂.

Table 564-2 summarizes the indoor air results relative to the sub-slab soil gas exceedances, since VI only potentially occurs if the analyte is present in both sub-slab soil gas and indoor air. Therefore, the table below provides the analyte detected above applicable screening levels in sub-slab soil gas as well as the corresponding indoor air sample result. The outdoor air sample result is also provided to determine if the analytes were present in indoor air due to migration from outdoor air.

Table 564-2. Vapor Intrusion Evaluation for Building 564

Analyte	Indoor Air Detection Frequency	Indoor Air Measured Range ($\mu\text{g}/\text{m}^3$)	Indoor Air Screening Level* ($\mu\text{g}/\text{m}^3$)	Outdoor Air Result ($\mu\text{g}/\text{m}^3$)
Tetrachloroethene (1)	21%	0.26 - 1	82	ND
Tetrachloroethene (2)	45%	0.22 - 3.4	82	ND
Tetrachloroethene (3)	73%	0.23 - 39	82	ND
Tetrachloroethene (4)	100%	0.31 - 1.6	82	ND
Trichloroethene (1)	71%	0.19 - 63	4	ND
Trichloroethene (2)	88%	3.5 - 2,700	4	ND
Trichloroethene (3)	80%	0.26 - 160	4	ND
Trichloroethene (4)	67%	0.23 - 81	4	ND

*Screening level provided is the draft project-specific RIASL₁₂.

All indoor air results for Building 564, with the exception of TCE during each event, are below screening levels. Therefore, further investigation activities were conducted at Building 564 in May 2019 (provided in Appendix D). The goals for the building-specific investigation for Building 564 were to gain an understanding of potential sources and distribution of TCE concentrations in the spare parts, shop and cage area located in the northwest corner of the building (Sample Locations 564-31, -36 and -37).

Baseline samples were collected at many of the previously sampled co-located indoor air and sub-slab soil gas locations, as well as additional sample locations within the building. An initial baseline reading from the shop area yielded an elevated result of TCE. Upon further investigation, several opened cans of Heavy Duty Flash Free Electrical Solvent (i.e., degreaser) containing over 90% TCE were found in the shop. In the spare parts room, approximately 10 unopened aerosol cans containing TCE and PCE were found on a storage shelf. The results of this initial day of sampling indicate that Building 564 appears to be locally impacted by degreaser aerosol cans. Sample results from other further investigation activities have demonstrated that simply storing the aerosol cans, opened or unopened, produces TCE and PCE emissions.

Follow-up samples, collected in and around the shop area, identified a large red distillate wash bin was discovered outside the cage area but under a ventilated hood. A sample collected outside the ventilated hood yielded a result of 110 ppbv TCE. A small headspace sample was taken within the wash bin that yielded a result of 7,380 ppbv TCE. It is suspected that this hood is used by occupants for cleaning parts after they first use TCE degreaser. It appears that the distillate solvent was recently changed prior to sampling because the liquid inside of the wash bin was translucent.

It was determined the source of elevated chlorinated concentrations is due to active workplace chemical use and is not attributable to VI. The frequent use of degreasers is the main source of the elevated chlorinated concentrations in Building 564. In total, approximately six dozen cans of aerosol degreaser containing 90% or more TCE and PCE were found in the northwest portion of the building, near the shop, spare parts, and cage area of Building 564. Furthermore, the presence and use of the distillate wash bin also contributed to elevated concentrations of TCE. Overall, the weight of evidence collected throughout the investigation confirms that the elevated chlorinated concentrations in Building 564 are due to active workplace chemical use and not attributable to VI.

VAPOR INTRUSION CONCEPTUAL SITE MODEL

VI is an exposure pathway that results from the migration of volatilized chemicals from the subsurface to indoor air in overlying occupied buildings. A source, migration route and a human receptor must be present for the VI pathway to be complete. The focus of this building specific investigation is to evaluate the potential VI exposure pathway for employees and contractors at Building 564. The CSM is illustrated in Figure 5.5.7-3.

Building 564 is a Category 2 building located within the northern portion of the facility designated as Zone 3. It is known as the Saran Building and is approximately 121,100 ft² in size. The building includes manufacturing, warehouse, laboratory area, and office space. The portion of the building containing the southern warehouse and shipping office, the main office area, locker rooms, and the final processing and packaging areas was built sometime between 1938 and 1952. The remainder of the building (additional warehouse space the shop space/lab space in the northwestern corner of the building) was built sometime between 1952 and 1958. It has slab-on-grade construction and the building is predominantly one to two stories tall but in the central part of the building, there are five stories. The office areas are on the west side of the building. The ground surface surrounding the building is a mixture of concrete and asphalt.

There are at least five AC units with inlets that mostly pull from inside the building or on the west side of the building. The warehouse office has an individual AC unit. The building has 26 bay doors which remain open during the summer (and for receiving shipments) and could affect ventilation rates and air mixing.

Approximately 30 - 35 people occupy this building during the day, including operators and office staff. Operations staff are present at the building 24 hours a day, seven days a week with 8-hour shifts. The office is present Monday through Friday for shifts ranging from 8am to 5pm or 6am to 3pm. The typical parameters for non-residential exposures are assumed to apply to the various personnel stationed during work shifts at this building (i.e., 40 hours/week, 50 weeks/year exposure).

A survey using a portable analyzer with a PID found no detectable VOCs at various drains, offices, lunch room, warehouse, and shop area. Readings of 0.5 and 0.8 parts per million by volume (ppmv) occurred at the drains in two bathrooms within the large building.

The chemical inventory performed during the building survey identified hundreds of potential indoor emission sources. The inventory indicated that chemicals of interest are stored and/or used within the building. For example:

- Sprayon EL848 Flash Free Electrical Degreaser contains 97.5% TCE;
- Sprayon S20848 Flash Free Safety Solvent & Degreaser contains 97.5% TCE;
- 3M Super 77 Multipurpose Adhesive contains 20-30% acetone;
- Lock-Ease Lock Fluid contains 15-20% acetone & alkanes;
- CRC Chain & Wire Rope Lubricant contains various hydrocarbons;
- Sprayon S00601 Red Insulating Varnish contains ethylbenzene, MEK and methyl isobutyl ketone (MIBK);
- Sprayon EL-601 contains CFC-134 and 2-propanol;
- CRC Zinc-It Instant Cold Galvanize contains xylenes and ethylbenzene; and

- Urinal/deodorizer cakes contain 1,4-DCB.

EVALUATION OF SEASONAL CONFIRMATION SAMPLING EVENTS

Four seasonal sampling events and one interim monitoring event have been completed at Building 564. The sampling events encompass more than one year of time and include sampling during each season of the year. The results from the four seasonal confirmation sampling events were evaluated with respect to spatial variability, temporal variability, and seasonal trend analysis.

Building specific attenuation factors (α) were calculated and compared between events to evaluate temporal variability and determine the best estimate of a building-specific attenuation factor. This evaluation serves to confirm that the existing study design is appropriate, and also provides insight for the determination of the path forward for this building.

This evaluation focused on any analytes detected in the sub-slab soil gas samples that met the criterion for inclusion in one or more of the following categories:

- a) Analytes detected in sub-slab soil-gas at concentrations that exceeded draft project-specific screening levels;
- b) Analytes detected in sub-slab soil-gas at concentrations of $1,000 \mu\text{g}/\text{m}^3$ or greater in one or more samples. Data for analytes detected above $1,000 \mu\text{g}/\text{m}^3$ should provide the clearest signal and be the simplest to interpret when assessing data trends. The same data trends observed for these analytes are expected to apply to other similar analytes present at lower concentrations; and
- c) PCE and TCE. These two analytes are of particular interest for many VI evaluations at industrial sites.

For this building, the only analytes detected in the sub-slab soil gas at concentrations above the draft project-specific screening levels were PCE and TCE. Two additional analytes had a detected concentration $\geq 1,000 \mu\text{g}/\text{m}^3$: acetone and total xylenes. Due to low detection frequency or intermittent detections, total xylenes is not included for further evaluation. Acetone was included for evaluation. Sample results for these three analytes are provided in the following data tables below:

Summary of Results for Tetrachloroethene (PCE)

Sample Type	Sample ID	Measured Concentration (µg/m ³)				Sample Type	Sample ID	Measured Concentration (µg/m ³)			
		Dec	Nov	Apr	Aug			Dec	Nov	Apr	Aug
		2017	2018	2019	2019			2017	2018	2019	2019
		E1	E2	E3	E4			E1	E2	E3	E4
Outdoor Air	564-OA-01	<0.21	<0.21	<0.22	0.48	Sub-Slab Soil Gas	564-SS-01	360	370	430	500
Indoor Air	564-IA-01	--	0.25	<0.24	0.75		564-SS-02	430	310	390	700
	564-IA-02	<0.24	0.32	0.37	0.89		564-SS-03	1200	1300	1200	1600
	564-IA-03	<0.22	0.25	0.24	0.85		564-SS-04	120	94	--	--
	564-IA-04	<0.22	<0.22	--	--		564-SS-05	84	64	--	--
	564-IA-05	<0.29	0.28	--	--		564-SS-06	16	35	--	--
	564-IA-06	<0.24	0.22	--	--		564-SS-07	22	27	--	--
	564-IA-07	<0.23	0.22	--	--		564-SS-08	11	15	--	--
	564-IA-08	<0.22	<0.22	--	--		564-SS-09	150	200	--	--
	564-IA-09	<0.22	<0.24	--	--		564-SS-10	630	720	--	--
	564-IA-10	<0.22	0.36	--	--		564-SS-11	71	84	--	--
	564-IA-11	<0.22	<0.24	--	--		564-SS-12	45	45	--	--
	564-IA-12	<0.22	<0.22	--	--		564-SS-13	33	29	17	31
	564-IA-13	<0.24	<0.23	0.23	1		564-SS-14	24	25	--	--
	564-IA-14	<0.24	0.23	--	--		564-SS-15	91	84	--	--
	564-IA-15	<0.24	0.34	--	--		564-SS-16	35	34	--	--
	564-IA-16	<0.23	0.23	--	--		564-SS-17	18	20	--	--
	564-IA-17	<0.24	<0.24	--	--		564-SS-18	21	20	--	--
	564-IA-18	<0.23	<0.22	--	--		564-SS-19	10	9	--	--
	564-IA-19	0.8	<0.23	--	--		564-SS-20	9.7	<11	14	8.3
	564-IA-20	<0.24	<0.23	<0.21	0.77		564-SS-21	6.7	8	--	--
	564-IA-21	<0.23	<0.22	--	--		564-SS-22	8.7	7.7	--	--
	564-IA-22	<0.24	<0.23	--	--		564-SS-23	<5.5	<5.1	--	--
	564-IA-23	<0.22	<0.24	--	--		564-SS-24	11	8.5	10	12
	564-IA-24	<0.23	<0.23	<0.34	0.31		564-SS-25	36	36	--	--
	564-IA-25	<0.23	<0.22	--	--		564-SS-26	12	14	--	--
	564-IA-26	1	<0.23	--	--		564-SS-27	7.1	9	--	--
	564-IA-27	<0.23	0.34	--	--		564-SS-28	10	12	--	--
	564-IA-28	<0.23	<0.24	--	--		564-SS-29	580	550	380	590
	564-IA-29	0.26	0.3	0.28	0.42		564-SS-30	12,000	14,000	8,000	9,800
	564-IA-30	0.74	0.66	4.3	1.6		564-SS-31	7,200	2,500	2,400	2,300
	564-IA-31	0.45	0.41	17	0.82		564-SS-32	390	390	--	--
	564-IA-32	0.35	<0.44	--	--		564-SS-33	1,100	520	--	--
	564-IA-33	<0.22	<0.56	--	--		564-SS-34	270	360	330	380

Summary of Results for Tetrachloroethene (PCE) (Continued)

Sample Type	Sample ID	Measured Concentration (µg/m ³)				Sample Type	Sample ID	Measured Concentration (µg/m ³)			
		Dec 2017	Nov 2018	Apr 2019	Aug 2019			Dec 2017	Nov 2018	Apr 2019	Aug 2019
		E1	E2	E3	E4			E1	E2	E3	E4
Indoor Air	564-IA-34	0.37	0.79	1.3	0.62	Sub-Slab Soil Gas	564-SS-35	2,100	1,100	2,300	2,500
	564-IA-35	<0.22	<1.5	0.7	0.6		564-SS-36	910	970	830	1,000
	564-IA-36	0.55	3.4	2.2	0.68		564-SS-37	4,000	5,400	5,100	4,100
	564-IA-37	0.63	0.49	39	0.77		564-SS-38	8.7	9.2	--	--
	564-IA-38	<0.23	<0.48	--	--		564-SS-39	17	22	--	--
	564-IA-39	<0.23	0.32	--	--		564-SS-40	370	230	--	--
	564-IA-40	<0.24	0.24	--	--		564-SS-41	430	600	590	610
	564-IA-41	0.32	0.31	0.4	0.97		564-SS-42	80	67	--	--
	564-IA-42	<0.24	<0.22	--	--		564-SS-43	--	130	110	170
	564-IA-43	<0.23	0.27	<0.22	0.41		564-SS-44	50	58	--	--
	564-IA-44	<0.23	<0.21	--	--		564-SS-45	28	25	--	--
	564-IA-45	<0.24	<0.22	--	--		564-SS-46	5.5	6.4	--	--
	564-IA-46	<0.24	<0.22	--	--		564-SS-47	<53	<52	--	--
	564-IA-47	<0.22	<0.23	--	--		564-SS-48	49	51	--	--
	564-IA-48	<0.23	<0.22	--	--		564-SS-49	70	70	--	--
564-IA-49	<0.23	0.3	--	--							

Screening levels for indoor air are 82 µg/m³ (RIASL₁₂/TSRIASL₁₂)
 Screening levels for soil-gas are 2700 µg/m³ (RIASL₁₂/TSRIASL₁₂)

	RIASL12 Exceedance
	TSRIASL12 Exceedance

Summary of Results for Trichloroethene (TCE)

Sample Type	Sample ID	Measured Concentration (µg/m³)				Sample Type	Sample ID	Measured Concentration (µg/m³)			
		Dec 2017	Nov 2018	Apr 2019	Aug 2019			Dec 2017	Nov 2018	Apr 2019	Aug 2019
		E1	E2	E3	E4			E1	E2	E3	E4
Outdoor Air	564-OA-01	<0.17	<0.17	<0.18	<0.19		564-SS-01	14	14	5.4	<4.3
Indoor Air	564-IA-01	--	8.5	0.68	0.82	Sub-Slab Soil Gas	564-SS-02	5.9	6.2	<4.3	7.1
	564-IA-02	0.6	7.1	0.26	0.23		564-SS-03	31	43	34	34
	564-IA-03	1.2	8	0.55	0.96		564-SS-04	<4.5	<4.5	--	--
	564-IA-04	0.32	9.9	--	--		564-SS-05	<4.1	<4.6	--	--
	564-IA-05	<0.23	7.6	--	--		564-SS-06	<4.2	<4.2	--	--
	564-IA-06	0.21	10	--	--		564-SS-07	<4.6	<4.6	--	--
	564-IA-07	0.29	7.1	--	--		564-SS-08	<3.9	<4.6	--	--
	564-IA-08	0.28	7	--	--		564-SS-09	<4.4	<4.4	--	--
	564-IA-09	0.27	7.5	--	--		564-SS-10	5.1	7.1	--	--
	564-IA-10	1.5	100	--	--		564-SS-11	<4.4	<3.9	--	--
	564-IA-11	0.28	8	--	--		564-SS-12	<4.3	<4.4	--	--
	564-IA-12	0.28	8.2	--	--		564-SS-13	<4.1	4.5	<4.3	<4.1
	564-IA-13	0.21	7.6	<0.18	<0.19		564-SS-14	<4.2	<4	--	--
	564-IA-14	0.26	7.9	--	--		564-SS-15	<4.2	<4.2	--	--
	564-IA-15	0.35	9.8	--	--		564-SS-16	<4.1	<4.3	--	--
	564-IA-16	0.2	10	--	--		564-SS-17	<8.9	<4.7	--	--
	564-IA-17	<0.19	4.5	--	--		564-SS-18	<4.2	<4.4	--	--
	564-IA-18	<0.18	3.5	--	--		564-SS-19	<4.1	6.4	--	--
	564-IA-19	0.28	19	--	--		564-SS-20	<4.5	32	<4.3	<4.2
	564-IA-20	<0.19	11	<0.17	<0.19		564-SS-21	<4.5	<4.4	--	--
	564-IA-21	<0.18	5.9	--	--		564-SS-22	13	<4.4	--	--
	564-IA-22	<0.19	<0.18	--	--		564-SS-23	<4.3	<4	--	--
	564-IA-23	<0.18	<0.19	--	--		564-SS-24	19	<4.8	<4.1	<4.4
	564-IA-24	<0.18	<0.18	<0.26	<0.2		564-SS-25	<4.5	<4.5	--	--
	564-IA-25	<0.18	<0.18	--	--		564-SS-26	<4.5	<4	--	--
	564-IA-26	<0.18	<0.18	--	--		564-SS-27	<4.1	<4.4	--	--
	564-IA-27	<0.18	<0.15	--	--		564-SS-28	<4.2	5.3	--	--
	564-IA-28	0.46	30	--	--		564-SS-29	<4.1	33	<4.1	<4.3
	564-IA-29	1.4	93	0.3	<0.19		564-SS-30	110	120	70	110
	564-IA-30	3	84	16	29		564-SS-31	76	20	14	16
	564-IA-31	24	35	72	12		564-SS-32	<4.4	<4.6	--	--
	564-IA-32	1	180	--	--		564-SS-33	<4.1	10	--	--
	564-IA-33	2.2	300	--	--		564-SS-34	5.7	23	5	<4.5

Summary of Results for Trichloroethene (TCE) (Continued)

Sample Type	Sample ID	Measured Concentration (µg/m³)				Sample Type	Sample ID	Measured Concentration (µg/m³)			
		Dec 2017	Nov 2018	Apr 2019	Aug 2019			Dec 2017	Nov 2018	Apr 2019	Aug 2019
		E1	E2	E3	E4			E1	E2	E3	E4
Indoor Air	564-IA-34	2.3	320	3.8	2.8	Sub-Slab Soil Gas	564-SS-35	6.1	13	<6.8	<8.9
	564-IA-35	5.4	750	2.5	6.1		564-SS-36	140	190	110	130
	564-IA-36	29	2700	10	53		564-SS-37	110	100	82	260
	564-IA-37	63	110	160	81		564-SS-38	14	<4.3	--	--
	564-IA-38	2.1	240	--	--		564-SS-39	<4.4	9.8	--	--
	564-IA-39	1.2	170	--	--		564-SS-40	<4.1	<4.3	--	--
	564-IA-40	0.26	10	--	--		564-SS-41	31	65	49	47
	564-IA-41	0.5	14	0.43	0.55		564-SS-42	<4.5	<4.7	--	--
	564-IA-42	0.26	10	--	--		564-SS-43	--	61	4.9	<4.6
	564-IA-43	0.25	120	0.29	<0.18		564-SS-44	<4.2	<4.4	--	--
	564-IA-44	<0.18	3.8	--	--		564-SS-45	<4.5	<3.6	--	--
	564-IA-45	<0.19	3.7	--	--		564-SS-46	<4.2	<4	--	--
	564-IA-46	0.19	9	--	--		564-SS-47	<42	<41	--	--
	564-IA-47	<0.17	4.4	--	--		564-SS-48	<4.5	<3.8	--	--
	564-IA-48	0.22	11	--	--		564-SS-49	<4	<4.4	--	--
564-IA-49	0.34	8.5	--	--							

Screening levels for indoor air are 4 µg/m³ (RIASL₁₂) and 12 µg/m³ (TSRIASL₁₂)
 Screening levels for soil-gas are 130 µg/m³ (RIASL₁₂) and 400 µg/m³ (TSRIASL₁₂)

	RIASL ₁₂ Exceedance
	TSRIASL ₁₂ Exceedance

Summary of Results for Acetone

Sample Type	Sample ID	Measured Concentration (µg/m ³)				Sample Type	Sample ID	Measured Concentration (µg/m ³)			
		Dec 2017	Nov 2018	Apr 2019	Aug 2019			Dec 2017	Nov 2018	Apr 2019	Aug 2019
		E1	E2	E3	E4			E1	E2	E3	E4
Outdoor Air	564-OA-01	7.5	4.5	11	14		564-SS-01	220	43	26	33
Indoor Air	564-IA-01	--	22	36	80	Sub-Slab Soil Gas	564-SS-02	39	23	25	21
	564-IA-02	30	26	85	100		564-SS-03	1300	19	68	30
	564-IA-03	44	18	32	82		564-SS-04	24	<20	--	--
	564-IA-04	50	42	--	--		564-SS-05	55	50	--	--
	564-IA-05	48	17	--	--		564-SS-06	31	34	--	--
	564-IA-06	49	44	--	--		564-SS-07	36	<20	--	--
	564-IA-07	45	93	--	--		564-SS-08	42	<20	--	--
	564-IA-08	43	120	--	--		564-SS-09	81	46	--	--
	564-IA-09	50	170	--	--		564-SS-10	160	26	--	--
	564-IA-10	9.7	28	--	--		564-SS-11	250	<17	--	--
	564-IA-11	46	150	--	--		564-SS-12	24	<19	--	--
	564-IA-12	43	58	--	--		564-SS-13	31	<20	<19	<18
	564-IA-13	36	110	64	95		564-SS-14	30	27	--	--
	564-IA-14	36	120	--	--		564-SS-15	32	<18	--	--
	564-IA-15	53	57	--	--		564-SS-16	29	<19	--	--
	564-IA-16	50	48	--	--		564-SS-17	<39	<21	--	--
	564-IA-17	99	24	--	--		564-SS-18	35	<20	--	--
	564-IA-18	28	25	--	--		564-SS-19	110	47	--	--
	564-IA-19	46	18	--	--		564-SS-20	870	<39	43	32
	564-IA-20	39	16	78	100		564-SS-21	160	27	--	--
	564-IA-21	4.3	14	--	--		564-SS-22	55	<19	--	--
	564-IA-22	5.8	17	--	--		564-SS-23	22	35	--	--
	564-IA-23	8	250	--	--		564-SS-24	150	<21	25	24
	564-IA-24	4.8	19	30	13		564-SS-25	52	<20	--	--
	564-IA-25	3.4	14	--	--		564-SS-26	160	20	--	--
	564-IA-26	4.6	15	--	--		564-SS-27	390	22	--	--
	564-IA-27	5.9	16	--	--		564-SS-28	170	<19	--	--
	564-IA-28	6.9	16	--	--		564-SS-29	200	51	50	42
	564-IA-29	4	21	18	22		564-SS-30	<200	88	<72	<140
	564-IA-30	7	100	46	21		564-SS-31	270	260	<36	<38
	564-IA-31	8.4	18	15	20		564-SS-32	230	<20	--	--
	564-IA-32	8.9	30	--	--		564-SS-33	80	<19	--	--
	564-IA-33	11	51	--	--		564-SS-34	29	<19	<19	<20
	564-IA-34	7.4	39	12	16		564-SS-35	99	62	<30	<39

Summary of Results for Acetone (Continued)

Sample Type	Sample ID	Measured Concentration ($\mu\text{g}/\text{m}^3$)				Sample Type	Sample ID	Measured Concentration ($\mu\text{g}/\text{m}^3$)			
		Dec 2017	Nov 2018	Apr 2019	Aug 2019			Dec 2017	Nov 2018	Apr 2019	Aug 2019
		E1	E2	E3	E4			E1	E2	E3	E4
Indoor Air	564-IA-35	3.6	58	13	19	Sub-Slab Soil Gas	564-SS-36	160	<20	25	24
	564-IA-36	8.8	1400	20	42		564-SS-37	160	<90	<78	<62
	564-IA-37	10	37	14	14		564-SS-38	48	<19	--	--
	564-IA-38	5.4	41	--	--		564-SS-39	210	30	--	--
	564-IA-39	5.9	32	--	--		564-SS-40	25	20	--	--
	564-IA-40	36	50	--	--		564-SS-41	170	430	38	48
	564-IA-41	57	31	68	71		564-SS-42	25	23	--	--
	564-IA-42	34	57	--	--		564-SS-43	--	180	190	130
	564-IA-43	40	25	30	12		564-SS-44	<18	<19	--	--
	564-IA-44	41	21	--	--		564-SS-45	28	19	--	--
	564-IA-45	30	20	--	--		564-SS-46	80	<18	--	--
	564-IA-46	53	37	--	--		564-SS-47	<180	<73	--	--
	564-IA-47	64	23	--	--		564-SS-48	53	26	--	--
	564-IA-48	43	46	--	--		564-SS-49	65	<19	--	--
564-IA-49	44	68	--	--							

Screening levels for indoor air are 31,000 (RIASL₁₂/TSRIASL₁₂)
 Screening levels for soil-gas are 1,000,000 $\mu\text{g}/\text{m}^3$ (RIASL₁₂/TSRIASL₁₂)

	RIASL12 Exceedance
	TSRIASL12 Exceedance

EVALUATION OF VI DATA TRENDS

Data trends for Building 564 are discussed below for both sub-slab soil gas and indoor air. When data exhibit a narrow range of variability, it is typical practice to express the range as a percentage (e.g., relative percent difference [RPD]). When data exhibit a large range of variability, however, it is more useful to express the range in orders of magnitude (i.e., factors of 10). This can be expressed mathematically as the log of the ratio of maximum/minimum values. If the values differ by a factor of 10, the log of the ratio is 1, if the values differ by a factor of 100, the log of the ratio is 2, and so on.

The variability across all locations over all sampling events is the total variability. This encompasses different types of variability, including spatial variability (i.e., how do the results vary from location to location), temporal variability (i.e., how do the results at a given location vary over time), and measurement variability. Measurement variability can be determined by evaluating results of duplicate or collocated samples and includes both sampling variability and analytical variability.

Sub-Slab Soil Gas Data Trends

Spatial Variability of Sub-Slab Soil Gas – The sub-slab soil gas exhibits up to three orders of magnitude of spatial variability. For example, sub-slab soil gas detections of PCE vary from 5.5 to 12,000 $\mu\text{g}/\text{m}^3$ (log of max./min. = 3.3) across all 49 locations for E1. Sub-slab soil gas detections of TCE range from 4.5 to 190 $\mu\text{g}/\text{m}^3$ (log of max./min. = 1.6), across all 49 locations for E2. Detected concentrations of acetone in sub-slab soil gas varies from 22 to 1,400 $\mu\text{g}/\text{m}^3$ (log max./min. = 1.7) across all nine locations for E1. Based on this data, there is a relatively modest amount of spatial variability in sub-slab soil gas given the size of the building and the number of sampling locations.

Temporal Variability of Soil Gas – The majority of sub-slab soil gas concentrations exhibit less than 1 order of magnitude variability but can exhibit, at most, slightly more than one order of magnitude depending on location and analyte. For PCE, all sub-slab soil gas concentrations vary less than one order of magnitude. For example, sub-slab soil gas concentrations of vary from 1,100 to 2,500 $\mu\text{g}/\text{m}^3$ at location 564-SS-35 (log max/min = 0.35). The results for other sample locations are similar for PCE. For TCE, sub-slab soil gas concentrations of vary from 110 to 190 $\mu\text{g}/\text{m}^3$ at location 564-SS-36 (log max/min = 0.24). Sub-slab soil gas concentrations of acetone vary from 24 to 260 $\mu\text{g}/\text{m}^3$ at location 564-SS-36 (log max/min = 0.82). Based on this evaluation, there is a relatively low amount of temporal variability in sub-slab soil gas which is in-line with expectations. Overall, as expected, the amount of temporal variability is less than the amount of spatial variability.

Seasonal Confirmation Sampling Trend Analysis – No formal statistical tests were performed, but the data exhibits relatively consistent results between the seasons. This is demonstrated by the graph below, which shows the three analytes selected above at locations where they were detected at relatively high concentrations. Note that the y-axis is a log scale.

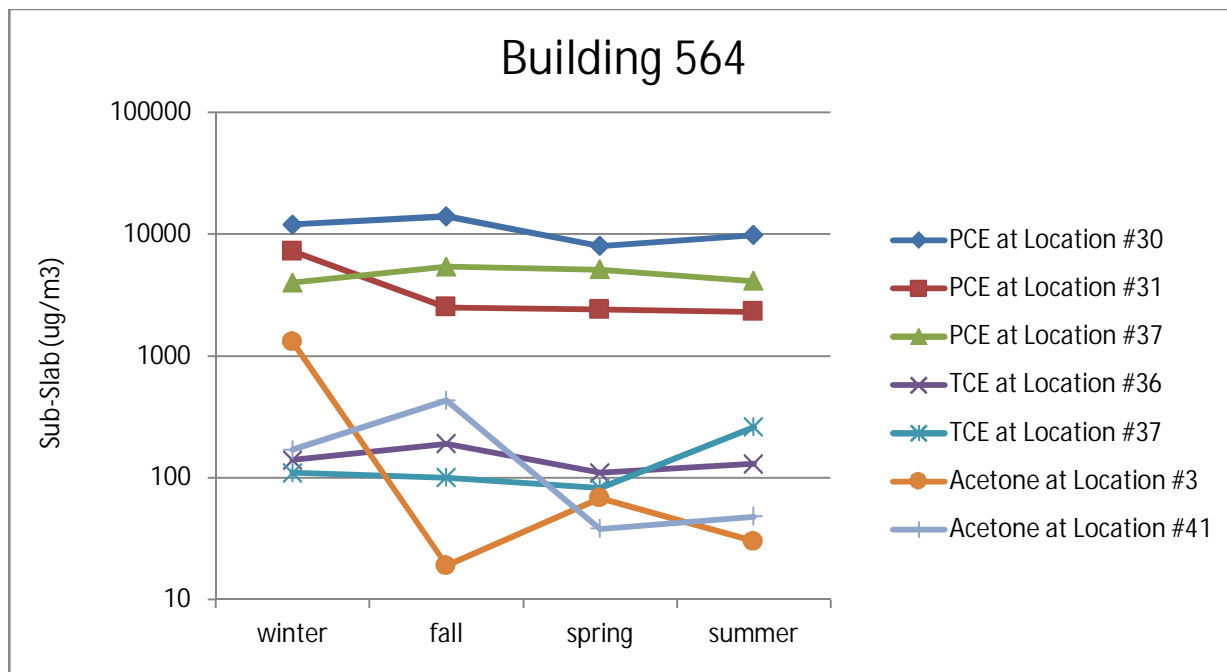

The data set was examined to see what the potential consequences would have been had only a single sampling event been performed. For PCE and TCE, the highest sub-slab soil gas concentrations were collected during winter (E1) and fall (E2), and the lowest concentrations occurred during the spring (E3). Overall, the minimum and maximum values appear to vary between sampling events.

For PCE, a concentration of 12,000 $\mu\text{g}/\text{m}^3$ was measured during E1 and the highest concentration (14,000 $\mu\text{g}/\text{m}^3$) was measured during E2. If only E1 had been performed, a negative bias of 17% would have been introduced (i.e., the E2 result was 17% higher than the E1 result). For TCE, the detected concentration in E1 was 110 $\mu\text{g}/\text{m}^3$ and the highest concentration overall (260 $\mu\text{g}/\text{m}^3$) was measured during E4. If only E1 had been performed, a negative bias over a factor of 2 would have been introduced. Therefore, implementing four seasonal confirmation sampling events provided some insight regarding maximum concentration levels and the larger data set served to increase the confidence in the findings.

Indoor Air Data Trends

Spatial Variability of Indoor Air – The indoor air exhibits approximately one to just less than 3 orders of magnitude of spatial variability. PCE had a detection frequency that ranged from 21% to 100% in indoor air across all sampling events. During E3, indoor air concentrations vary from 0.23 to 39 $\mu\text{g}/\text{m}^3$ (log max./min. = 2.2). The other events saw less variability. For TCE, the highest spatial variability occurred during E2 where indoor air concentrations vary from 3.5 to 2,700 $\mu\text{g}/\text{m}^3$ (log max./min. = 2.9). Acetone exhibited the greatest variability in E2, ranging from 14 to 1,400 $\mu\text{g}/\text{m}^3$ (log max./min. = 2).

Temporal Variability of Indoor Air – The indoor air exhibits up to two orders of magnitude of temporal variability. For example, indoor air concentrations of PCE at location 564-IA-37 varied from 0.49 to 39 $\mu\text{g}/\text{m}^3$ (log of max./min. = 1.9). For TCE at location 564-IA-36, concentrations varied from 10 to 2,700 $\mu\text{g}/\text{m}^3$ (log max./min. = 2.4). Indoor air concentrations of acetone at 564-IA-36 varied from 8.8 to 1,400 $\mu\text{g}/\text{m}^3$ (log max./min. = 2.2). Overall, temporal variability across the four seasons sampled is similar to the spatial variability of the indoor air.

Additional Analyses

Comparison of Sub-Slab Soil Gas and Indoor Air Data Sets –The sub-slab soil gas data exhibit a similar level of spatial variability when compared to the indoor air data set. The sub-slab soil gas exhibits less temporal variability than the indoor air data set. This suggests that there are significant indoor sources of the AOIs or that emissions from any indoor air sources tend to be well distributed in this building.

Seasonal Effects – The sub-slab soil gas data exhibit relatively little variability from event to event. Maximum sub-slab soil gas values for PCE occurred in E1 and E2 (winter and fall) and for TCE in E2 and E4 (fall and summer). Maximum indoor air values for PCE occurred in E3 (spring) and maximum detections for TCE occurred in E2 (fall). The data vary but do not support the hypothesis that wintertime should have the highest indoor air impacts.

Comparison of Attenuation Factors by Event – Attenuation factors were calculated for PCE based on maximum values since PCE had a high detection frequency in sub-slab soil gas for all events and a high detection frequency during E3 and E4 for indoor air. Also, detections in outdoor air were limited. Therefore, the indoor air maximum concentration was corrected for contribution of outdoor air to indoor air (e.g., outdoor air detected concentration was subtracted from indoor air concentration). The calculated event-specific attenuation factors are shown in Tables 564-3.

Table 564-3. Comparison of Building-Specific Attenuation Factors for PCE by Event

	E1 (Winter)	E2 (Fall)	E3 (Spring)	E4 (Summer)
Maximum Values				
PCE in Sub-Slab Soil Gas ($\mu\text{g}/\text{m}^3$)	12,000	14,000	8,000	9,800
PCE in Outdoor Air ($\mu\text{g}/\text{m}^3$)	ND	ND	ND	0.48
PCE in Indoor Air ($\mu\text{g}/\text{m}^3$)	1	3.4	39	1.6
PCE in Indoor Air ($\mu\text{g}/\text{m}^3$) Corrected for Outdoor Air Contribution	1	3.4	39	1.1
Attenuation Factor	8.3E-05	2.4E-04	4.9E-03	1.1E-04

These serve as the best estimates of attenuation at this building. The results can vary from day to day due to differences in rates of vapor intrusion and rates of building ventilation. Overall, the most conservative estimate of a building-specific attenuation factor for Building 564 is 4.9E-03 based on PCE during E3.

Temporal Variability in Attenuation Factor – As shown in the table above, there was about two orders magnitude of temporal variability in the calculated attenuation factors observed for PCE.

To be as conservative as possible, the maximum values were used in calculating the attenuation factor for each event. The sampling location with the maximum value per event varied. Generally, the maximum indoor air values were similar across events. In general, the low spatial variability in indoor air results means that roughly comparable attenuation factors would be obtained whichever indoor air value was used in the calculations.

NON-DETECT EVALUATION

Table 564-4 below lists the analytes in sub-slab soil gas that have ND RLs greater than the screening levels. The table also includes the indoor air results for each of the analytes. If a sub-slab soil gas analyte has ND RL exceedances, but all results and ND RLs in indoor air are below the screening levels, no further evaluation is warranted. If an analyte was identified as an AOI in sub-slab soil gas (detected results > screening level), it is excluded from the ND evaluation. Also, if an ND analyte has an 0% detection frequency for all sampling events and all ND RLs met the screening level during at least one event, no further ND evaluation is warranted.

Table 564-4. Non-Detect Evaluation for Building 564

Soil Gas Analytes with ND RL > SL	Indoor Air Result Summary
1,1,2-Trichloroethane	0% Detection Frequency, All ND RLs < RIASL ₁₂
1,2,4-Trichlorobenzene	0% Detection Frequency, >40% ND RLs < RIASL ₁₂ in E1 through E3; >10% ND RLs < RIASL ₁₂ in E4
1,2-Dibromoethane (EDB)	0% Detection Frequency, All ND RLs > RIASL ₁₂ in E1 through E3; All ND RLs < RIASL ₁₂ in E4
Hexachlorobutadiene (HCB)	0% Detection Frequency, All ND RLs > RIASL ₁₂ in E1 through E3; All ND RLs < RIASL ₁₂ in E4
Naphthalene	0% Detection Frequency, All ND RLs < RIASL ₁₂ in E1, E3 and E4; 98% of ND RLs < RIASL ₁₂ in E2

WEIGHT-OF-EVIDENCE SUMMARY

Building 564 was confirmed as a VI Path Forward Group 4A building due to its potential for VI based on indoor air exceedances and/or sub-slab soil exceedances of the draft project-specific RIASL₁₂ and/or TSRIASL₁₂. However, after further investigation and evaluation, the following evidence supports the conclusion that VI is insignificant at Building 564:

- The sub-slab soil gas results indicate that concentrations are stable or decreasing.
- All indoor air results are less than the draft project-specific screening levels, with the exception of PCE. Indoor sources were identified during the further investigation completed in May 2019. The maximum detected results of PCE in indoor air are less than 1% of the Dow OEL.
- Based on the results of the October 2019 further investigation activities, it is likely that the source of PCE and TCE in the indoor air in 564 is routine workplace chemical use. In total, approximately six dozen cans of aerosol degreaser containing 90% or more TCE and PCE were found in the northwest portion of the building, near the shop, spare parts, and cage area. Furthermore, the presence and use of the distillate wash bin also contributed to elevated concentrations of TCE.
- The sub-slab soil gas data do not show any strong time dependence nor do the data show any strong seasonal effects.
- Though the data varies, the data do support the hypothesis that wintertime should have the highest indoor air impacts.
- The indoor air data shows relatively high spatial variability, despite the lower spatial variability in the sub-slab soil gas values. This evaluation confirms that indoor sources are present and in use.
- As shown in the table below, the building-specific attenuation factor yields estimated indoor air concentrations for EDB and HCB below the RIASL₁₂. For EDB, the maximum ND RL occurred at location 564-SS-30 during E1 and lower reporting limits were achieved during all other events. If the ND RL from E4 is used (44 ug/m³) the estimated indoor air concentration (0.21 ug/m³) is nearly equal to the screening level.

Parameters	EDB	HCBD
Building-specific AF	4.9E-03	4.9E-03
Maximum reporting limit in SSSG	<69	<380
Estimated Indoor Air Concentration	0.34	1.85
Indoor Air ND RL	<2.6	<88
Indoor Air RIASL ₁₂	0.2	5.4

Based on the four seasonal confirmation sampling events, the further investigation activities and the CSM for Building 564, VI is an insignificant exposure pathway for current building utilization.

PATH FORWARD

Based on the evaluation of the four seasonal confirmation sampling events, the VI pathway continues to be insignificant for Building 564 and the sub-slab soil gas results have demonstrated relatively stable concentrations and no evidence of increasing over time. Elevated levels of TCE and PCE appear to be due to routine work place chemical use. Sufficient information exists to make a human exposure under control EI determination. However, while currently there is no evidence of potential VI, for future use, LTM is warranted and the building-specific Interim Monitoring Plan is discussed below.

Building-specific Interim Monitoring Plan

Dow presented an interim monitoring plan for Building 564 during the October 2019 Corrective Action status meeting. Dow will implement the interim monitoring plan at Building 564 until a revised program or more permanent corrective action plan is developed for the site.

Indoor air will be monitored at location 564-IA-30. This location was selected for continued monitoring since it demonstrated the highest sub-slab soil gas results. Monitoring will be performed for PCE and TCE. An outdoor air sample will also be collected at the time of each monitoring event. Interim monitoring will be performed semi-annually for a minimum of two years and monitoring results will undergo trend analysis. Monitoring will begin in Winter 2019/2020. If results continue to be consistent and below screening levels, monitoring will be conducted on an annual basis. If indoor air results are observed to be increasing, further evaluation will be performed, which may include collection of a sub-slab soil gas sample(s) and an increase in monitoring frequency. Results from each monitoring event will be reported in the annual CAIP. In the event an indoor air result(s) exceeds screening levels, EGLE will be provided a brief email notification. A collocated indoor air and sub-slab soil gas sample will be collected from that location within 45 days. If both sub-slab soil gas and indoor air results indicate that VI continues to be insignificant, monitoring will continue at an appropriate frequency. If both sub-slab soil gas and indoor air results indicate that VI is significant and confirm Group 4 conditions, the building will be moved to Group 4 for follow-up actions.

Dow may propose changes to the frequency or other aspects of this interim monitoring plan in the future based on an evaluation of the data, changes in building use or implementation of other corrective actions to address the potential VI pathway.

5.5.8 Vapor Intrusion Evaluation for Building 881

BACKGROUND

Building 881 is located in the northwestern quadrant of the Midland facility (Figure 5.5.8-1). The northern half of the building was built in the 1970s and the southern half of the building was built in the 1990s. This building contains large locker rooms with washer/dryers, two shops (one which has an office setup), a storage area, and a server room. The entire structure has a footprint of approximately 5,391 ft² and is a one-story slab-on-grade construction with no elevator or basement. The shop portions of the building have a ceiling height equivalent to two stories.

The building is cooled via one central AC unit with an associated intake located on the east side of the building near the southeastern corner. The shop portions of the building are heated via steam radiation, but the locker room areas are heated via hot air circulation. There are two bay doors on this structure, which are associated with the northwestern shop/garage area. The bay doors are only open when accessing equipment or dropping off materials. The outside ground cover surrounding the building consists of asphalt and gravel. Fuel-powered equipment is frequently stored in the northwest shop/garage area. Occupants of the building do use the washer/dryers in the locker rooms, but an outside laundry service is also provided on a weekly basis.

No PID detections were observed in the ambient air throughout the building, but a PID detection of 1.2 ppm was observed from the drain located in the northwestern garage/shop area.

EXPEDITED REPORTING

An EBS was provided in February 2019 based on the Fall 2018 sampling event and EGLE's request for expedited reporting if an indoor air result exceeds the TSRIASL₁₂. Email notifications were provided in January, July and October 2019. Seasonal confirmation sampling has continued for both sub-slab soil gas and indoor air. Dow conducted further investigation activities at Building 881 in May and July 2019 and results were presented to EGLE during the monthly Corrective Action Status meetings. A Summary of Investigative Findings documenting the further investigation activities was submitted to EGLE in October 2019 and is summarized below.

Further Investigation Activities

Based on the results from the initial sampling event (E1), further investigation activities were conducted for Building 881 and documented in the Summary of Investigative Findings (October 2019). The goals for the building-specific investigation for Building 881 were to gain an understanding of potential sources and distribution of TCE concentrations. Appendix C presents the October 2019 Summary of Further Investigation Findings report.

On May 8th, baseline samples were collected at the previous indoor air and sub-slab soil gas locations and all breathing zone samples were below 0.1 ppbv (0.54 $\mu\text{g}/\text{m}^3$) TCE, with the exception of 0.18 ppbv TCE found at location 881-04 in the eastern shop area. Three opened Heavy Duty Flash Free Electrical Solvent aerosol canisters (i.e., degreaser) containing over 90% TCE were identified in the eastern shop. An additional sample was collected at the cabinet that contained two of the opened TCE aerosol degreaser cans (881-04CANS) with a result of 13.36 ppbv TCE.

On July 9th, follow-up baseline samples were collected at the same sampling locations as the May investigation and again, all breathing zone samples collected during this second baseline sampling were below 0.1 ppbv TCE, with the exception of the 881-04 location at 0.21 ppbv TCE. Open TCE degreaser cans were found again in cabinets in the eastern shop. A sample was collected at the cabinet containing one of the open TCE degreaser cans near the original 881-04CANS location (0.84 ppbv).

During both investigations, potential preferential pathways were investigated again with a PID, and no significant VOC concentrations were detected.

A very apparent concentration gradient originated from the cabinet storing open TCE aerosol degreaser cans in Building 881. It was determined the source of elevated TCE concentrations at Building 881 is due to active workplace chemical use and storage of TCE aerosol degreaser cans and not attributable to VI.

DATA SUMMARY

Building 881 has undergone three seasonal confirmation sampling events. Seasonal confirmation sampling was conducted at Building 881 since results from the initial sampling event exceeded screening levels. The analytical results from each of the sampling events were compared to the June 22, 2018

EGLE draft project-specific 12-hour Soil Gas screening values and AACs (draft project-specific RIASL₁₂ and TSRIASL₁₂, if available).

Building 881	
Initial Sampling Event	Completed
E1	September 2018 (Fall)
Seasonal Sampling Event	Completed
E2	April 2019 (Spring)
E3	August 2019 (Summer)
E4	Scheduled - Winter 2019

For each sampling event, sub-slab soil gas samples were collected from four locations from within the building. Indoor air samples were collected at four locations corresponding to the soil gas sample locations, along with an outdoor air sample from the main air intake. The sampling locations are shown on Figure 5.5.8-2. Summary statistics and screening comparison results are presented for sub-slab soil gas on Table 5.5.8-A and indoor and outdoor air on Table 5.5.8-B. The analytical data is presented in Appendix A. Field sampling forms are provided in Appendix B. Sub-slab soil gas and indoor air results for each sample location and sampling event is provided for TCE on Figure 881-1.

The building survey completed before the initial sampling event can be found in Appendix D. Drains and other openings were screened with a PID and no soil gas entry points were identified. The chemical inventory performed during the building survey identified various potential indoor emission sources, including soap, air freshener, and various adhesive sprays, lubricants, and spray paints. The building has running water, which is a potential source of chloroform, but no specific consumer items containing chloroform were identified.

SUB-SLAB SOIL GAS RESULTS EVALUATION

Analytical results were evaluated based on methodologies presented in the 2018 Revised Vapor Intrusion Work Plan. The number of analytes detected above the sub-slab soil gas draft project-specific RIASL₁₂ or TSRIASL₁₂, if available, are discussed below by sampling event and shown on Table 881-1:

1. During the initial event (Fall 2018), three analytes were detected above the draft project-specific RIASL₁₂, and TCE and 1,1-DCA also exceeded the TSRIASL₁₂;
2. During the second event (Spring 2019), two analytes were detected above the draft project-specific RIASL₁₂ but did not exceed the TSRIASL₁₂; and
3. During the third event (Summer 2019), one analyte was detected above the draft project-specific RIASL₁₂ but was less than the TSRIASL₁₂.

Table 881-1. Summary of Sub-Slab Soil Gas Exceedances for Building 881

Analyte	Detection Frequency	Measured Range of Detects (µg/m ³)	% Detections > Screening Level	Screening Level* (µg/m ³)
1,1-Dichloroethane (1)	100%	4.5 - 110,000	25%	2,500
1,1-Dichloroethane (2)	75%	24 - 1,500	0%	2,500
1,1-Dichloroethane (3)	100%	3.6 - 5,300	25%	2,500
Chloroform (1)	100%	23 - 620	75%	170
Chloroform (2)	100%	8.2 - 340	25%	170
Chloroform (3)	100%	27 - 64	0%	170
Trichloroethene (1)	100%	43 - 430	75%	130
Trichloroethene (2)	50%	130 - 210	25%	130
Trichloroethene (3)	50%	50 - 65	0%	130

*Screening level provided is the draft project-specific RIASL₁₂.

EVALUATION OF VAPOR INTRUSION

Table 881-2 summarizes the indoor air results relative to the sub-slab soil gas exceedances, since VI only potentially occurs if the analyte is present in both sub-slab soil gas and indoor air. Therefore, the table below provides the analytes detected above applicable screening levels in sub-slab soil gas as well as the corresponding indoor air sample results. The outdoor air sample results are also provided to determine if the analytes were present in indoor air due to migration from outdoor air.

Table 881-2. Vapor Intrusion Evaluation for Building 881

Analyte	Indoor Air Detection Frequency	Indoor Air Measured Range ($\mu\text{g}/\text{m}^3$)	Indoor Air Screening Level* ($\mu\text{g}/\text{m}^3$)	Outdoor Air Result ($\mu\text{g}/\text{m}^3$)
1,1-Dichloroethane (1)	25%	0.20	74	ND
1,1-Dichloroethane (2)	0%	ND	74	ND
1,1-Dichloroethane (3)	25%	0.36	74	ND
Chloroform (1)	0%	ND	ND	ND
Chloroform (2)	0%	ND	ND	ND
Chloroform (3)	0%	ND	ND	ND
Trichloroethene (1)	0%	ND	ND	ND
Trichloroethene (2)	0%	ND	ND	ND
Trichloroethene (3)	0%	ND	ND	ND

*Screening level provided is the draft project-specific RIASL₁₂.

As shown in tables 881-1 and 881-2, while 1,1-DCA, chloroform and TCE exceeded the RIASL₁₂ and TSRIASL₁₂ (for 1,1-DCA and TCE only) in sub-slab soil gas, chloroform and TCE were not detected in indoor air. 1,1-DCA was detected but at levels less than screening levels. Sub-slab soil gas and indoor air results for TCE by sample location are provided on Figure 5.5.8-2. Sub-slab soil gas results have generally decreased over time and the further investigation activities confirmed that active workplace chemical use is occurring in both shop areas. The maximum result of 1,1-DCA detected in indoor air at Building 881 was 0.36 $\mu\text{g}/\text{m}^3$, which is < 1% of the Dow OEL. A full ND evaluation will be performed upon the completion of seasonal confirmation sampling in the 2020 CAIP.

CONCLUSIONS AND RECOMMENDATIONS

Based on the indoor air results and further investigation findings, the VI pathway at Building 881 is an insignificant exposure pathway based on current use. However, based on the sub-slab soil gas results and given the potential for future VI, Building 881 has been placed in VI Path Forward Building Group 4A, as lines of evidence indicate that VI is insignificant and the presence and use of degreasers in Building 881 indicate active workplace chemical use. The final seasonal confirmation sampling event is scheduled for Winter 2019 (December). A full evaluation will be presented in the 2020 CAIP.



Figure 881-1

TCE	Soil Gas	Indoor Air
	ug/m ³	ug/m ³
Event 1	380	0.7
Event 2	210	0.33
Event 3	50	1.6

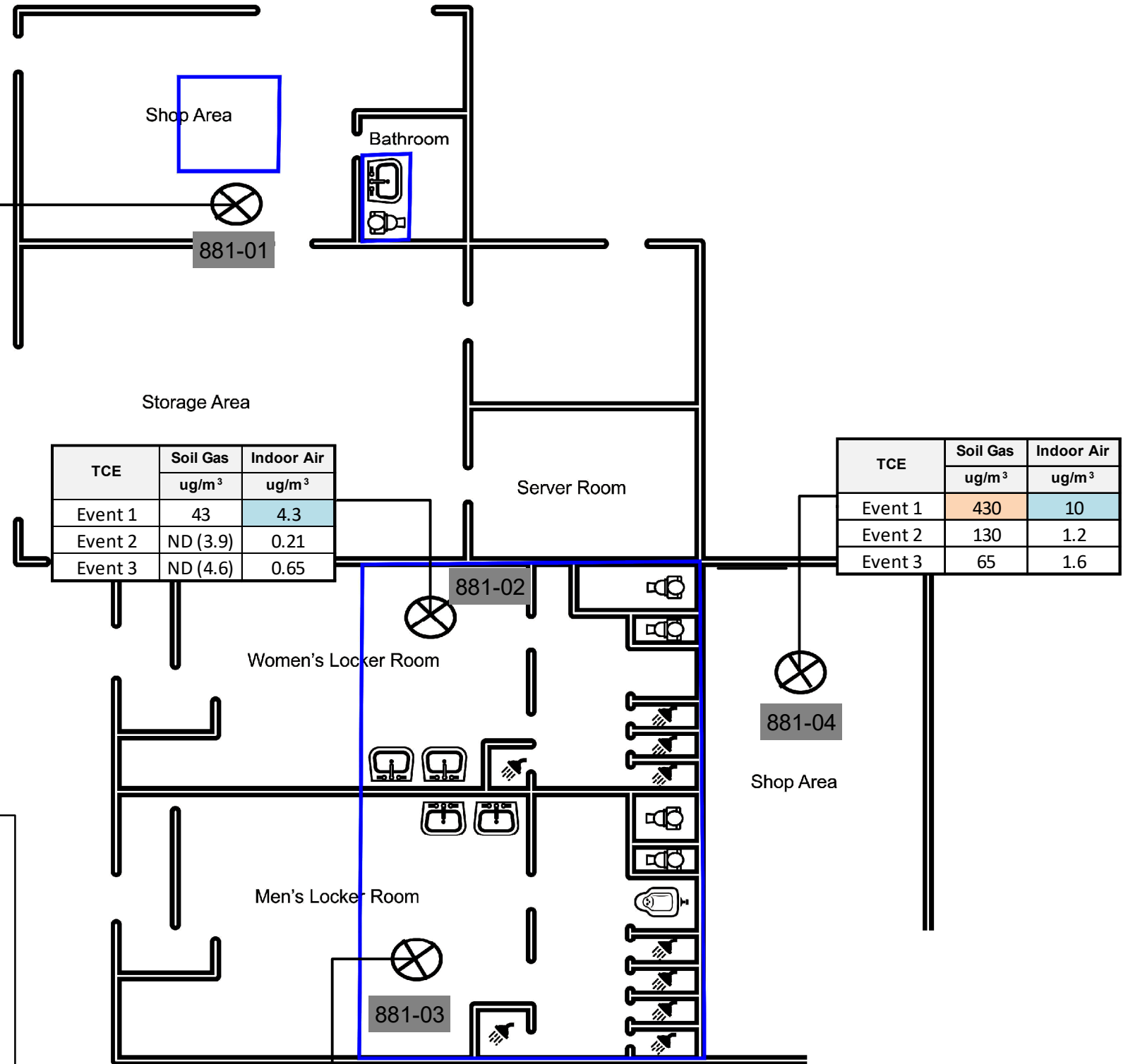

TCE	Soil Gas	Indoor Air
	ug/m ³	ug/m ³
Event 1	43	4.3
Event 2	ND (3.9)	0.21
Event 3	ND (4.6)	0.65

TCE	Soil Gas	Indoor Air
	ug/m ³	ug/m ³
Event 1	430	10
Event 2	130	1.2
Event 3	65	1.6

TCE	Soil Gas	Indoor Air
	ug/m ³	ug/m ³
Event 1	210	4.2
Event 2	ND (6.7)	0.2
Event 3	ND (22)	0.63

Legend

- 881-## Sub-slab/Indoor Air Location
- Preferential Pathways Observed (drains)
- Exceeds RIASL₁₂ Only
- Exceeds TSRIASL₁₂
- Exceeds Dow OEL

Media	COC	RIASL ₁₂	TSRIASL ₁₂	OEL
Soil Gas	TCE	130	400	--
Indoor Air	TCE	4	12	26,850

Notes:

- All units ug/m³
- Initial Sampling
Event 1 = September 2018
- Seasonal Confirmation Sampling
Event 1 = April 2019
- Seasonal Sampling
Event 3 = August 2019
- Outdoor ambient placed by intake located outside of southeastern shop area.

TCE	Outdoor Air Sample
	ug/m ³
Event 1	ND (0.18)
Event 2	ND (0.17)
Event 3	ND (0.18)

Sub-slab Soil Gas and Indoor Air Results for Trichloroethene Zone 3 Phase 1 Sampling Event 1-3 Building 881

5.5.9 Vapor Intrusion Evaluation for Building 1037

Building 1037 contains a control room with a kitchen, but otherwise the remainder of the structure is predominantly warehouse or process space, with some of the process space being located outdoors. A structure has existed on this plot since pre-1938 per aerial photographs. The present structure, with a footprint of 19,396.65 ft² was constructed in the 1970s and is located in the southwestern quadrant of the Midland facility (Figure 5.5.9-1). The structure is slab-on-grade construction (with the grade having been built up approximately 3 ft above natural ground surface), with no basement or elevator. The floor in the building is predominantly painted concrete. The building is predominantly one-story with the exception of a small area located on the western side of the building; however, the ceiling heights throughout the majority of the structure are comparable to the height of a two-story structure. Approximately 10-15 occupants work in Building 1037, on 8-hour shifts Monday through Friday.

The building has seven bay doors, many of which are open more frequently during warmer months and are open during colder months only for loading trucks and moving materials and equipment in and out of the building. The control room area located in the western portion of the building has a central AC unit, and another unit is located on the northern side of the building. The entire structure is heated via steam radiation. The building has two intakes: one is located near the southwestern corner and the other is located on the northern side of the building. There are also two large vents located on the south and east sides of the building. The surrounding ground cover outside of the building is predominantly concrete or asphalt with some gravel areas located to the south. Propane-fueled fork trucks are used in the building and occupants use a washer/dryer on site.

No PID detections were observed in the ambient air or from any drain features at the time of the survey.

DATA SUMMARY

Building 1037 has undergone three seasonal confirmation sampling events. Seasonal confirmation sampling was conducted at Building 1037 since results from the initial sampling event exceeded screening levels. The analytical results from each of the sampling events were compared to the June 22, 2018 EGLE draft project-specific 12-hour Soil Gas screening values and AACs (draft project-specific RIASL₁₂ and TSRIASL₁₂, if available).

Building 1037	
Initial Sampling Event	Completed
E1	September 2018 (Fall)
Seasonal Sampling Event	Completed
E2	April 2019 (Spring)
E3	August 2019 (Summer)
E4	<i>Scheduled - Winter 2019</i>

For each sampling event, sub-slab soil gas samples were collected from nine locations from within the building. Indoor air samples were collected at nine locations corresponding to the soil gas sample locations, along with an outdoor air sample from the main air intake. The sampling locations are shown on Figure 5.5.9-2. Summary statistics and screening comparison results are presented for sub-slab soil gas on Table 5.5.9-A and indoor and outdoor air on Table 5.5.9-B. The analytical data is presented in Appendix A. Field sampling forms are provided in Appendix B.

The building survey completed before the initial sampling event can be found in Appendix D. Drains and other openings were screened with a PID and no soil gas entry points were identified. A chemical inventory was completed during the building survey and the chemicals found to be stored within the building are listed in the survey.

SUB-SLAB SOIL GAS RESULTS EVALUATION

Analytical results were evaluated based on methodologies presented in the 2018 Revised Vapor Intrusion Work Plan. The number of analytes detected above the sub-slab soil gas draft project-specific RIASL₁₂ or TSRIASL₁₂, if available, are discussed below by sampling event and shown on Table 1037-1:

1. During the initial event (Fall 2018), three analytes were detected above the draft project-specific RIASL₁₂ including 1,2,4-TCB and benzene, which were also detected above the TSRIASL₁₂;
2. During the second event (Spring 2019), three analytes were detected above the draft project-specific RIASL₁₂ including 1,2,4-TCB and benzene, which were also detected above the TSRIASL₁₂; and
3. During the third event (Summer 2018), two analytes were detected above the draft project-specific RIASL₁₂ including benzene, which was also detected above the TSRIASL₁₂.

Table 1037-1. Summary of Sub-Slab Soil Gas Exceedances for Building 1037

Analyte (Sampling Event)	Detection Frequency	Measured Range of Detects ($\mu\text{g}/\text{m}^3$)	% Detections > Screening Level* ($\mu\text{g}/\text{m}^3$)	Screening Level* ($\mu\text{g}/\text{m}^3$)
1,2,4-Trichlorobenzene (1)	11%	28,000	11%	200
1,2,4-Trichlorobenzene (2)	11%	3,100	11%	200
1,2,4-Trichlorobenzene (3)	0%	ND	0%	200
1,4-Dichlorobenzene (1)	100%	16 - 3,300	22%	1,000
1,4-Dichlorobenzene (2)	78%	5.9 - 1,800	11%	1,000
1,4-Dichlorobenzene (3)	78%	12 - 7,500	11%	1,000
Benzene (1)	100%	28 - 31,000	67%	510
Benzene (2)	100%	12 - 30,000	56%	510
Benzene (3)	89%	12 - 30,000	56%	510

*Screening level provided is the draft project-specific RIASL₁₂.

EVALUATION OF VAPOR INTRUSION

Table 1037-2 summarizes the indoor air results relative to the sub-slab soil gas exceedances, since VI only potentially occurs if the analyte is present in both sub-slab soil gas and indoor air. Therefore, the table below provides the analytes detected above applicable screening levels in sub-slab soil gas as well as the corresponding indoor air sample results. The outdoor air sample results are also provided to determine if the analytes were present in indoor air due to migration from outdoor air.

Table 1037-2. Vapor Intrusion Evaluation for Building 1037

Analyte (Sampling Event)	Indoor Air Detection Frequency	Indoor Air Measured Range ($\mu\text{g}/\text{m}^3$)	Indoor Air Screening Level* ($\mu\text{g}/\text{m}^3$)	Outdoor Air Result ($\mu\text{g}/\text{m}^3$)
1,2,4-Trichlorobenzene (1)	0%	ND	6.2	ND
1,2,4-Trichlorobenzene (2)	0%	ND	6.2	ND
1,2,4-Trichlorobenzene (3)	0%	ND	6.2	ND
1,4-Dichlorobenzene (1)	22%	0.19 - 0.2	30	ND
1,4-Dichlorobenzene (2)	100%	0.28 - 1	30	ND
1,4-Dichlorobenzene (3)	100%	0.47 - 1.6	30	ND
Benzene (1)	100%	1.7 - 6.5	15.4	2.7
Benzene (2)	100%	0.82 - 1.8	15.4	0.72
Benzene (3)	100%	1.5 - 8.5	15.4	1.2

*Screening level provided is the draft project-specific RIASL₁₂.

All indoor air results are less than screening levels. While detected concentrations of 1,2,4-TCB were above the TSRIASL₁₂ in sub-slab soil gas, it was not detected in indoor air. Benzene concentrations were greater than the TSRIASL₁₂ at several sample locations, detected concentrations in indoor air are less than the screening level and the detected range is similar to results in outdoor air. 1,4-DCB did not exceed the TSRIASL₁₂ in sub-slab soil gas and indoor air results were less than screening levels. The maximum results for 1,2,4-TCB, 1,4-DCB and benzene in indoor air at Building 1037 are all < 1% of the Dow OEL. A full ND evaluation will be performed upon the completion of seasonal confirmation sampling in the 2020 CAIP.

CONCLUSIONS AND RECOMMENDATIONS

Based on the indoor air results, the VI pathway at Building 1037 is an insignificant exposure pathway based on current use. However, based on the sub-slab soil gas results and given the potential for future VI, Building 1037 has been placed in VI Path Forward Building Group 2, as lines of evidence indicate that VI is insignificant and all indoor air results are less than screening levels. The final seasonal confirmation sampling event is scheduled for Winter 2019. A full evaluation will be presented in the 2020 CAIP.

5.5.10 Vapor Intrusion Evaluation for Building 1042

BACKGROUND

Building 1042 was built in the 1970s and is located in the southwestern quadrant of the Midland facility (Figure 5.5.10-1). This structure, with a footprint of 5,600 ft², is predominantly warehouse space aligned with/used by the chemical distribution operation positioned in Building 954, but it also has two small office spaces located in the southeastern corner that are used by an insulator contractor. The building is a slab-on-grade construction with no elevator and no basement.

The only area of the building with any climate control is the office area, which has two individual AC units for cooling and electric baseboards for heating. The building has three bay doors and one railcar door, which are open when moving materials or the track mobile in and out of the building. The bay doors are large enough to allow a fuel-operated vehicle to pull in and out of the warehouse portion of the building. The outdoor ground cover surrounding the building consists of grass and gravel to the north, and asphalt and gravel to the east, south, and west. Building 1042 only has one occupant who works 10-hour shifts Monday through Thursday.

No PID detections were observed in the ambient air throughout the building or from the drain feature observed northwest of the offices at the time of the survey. Of note, the office area is on a slightly raised floor.

DATA SUMMARY

Building 1042 has undergone three seasonal confirmation sampling events. Seasonal confirmation sampling was conducted at Building 1042 since results from the initial sampling event exceeded screening levels. The analytical results from each of the sampling events were compared to the June 22, 2018 EGLE draft project-specific 12-hour Soil Gas screening values and AACs (draft project-specific RIASL₁₂ and TSRIASL₁₂, if available).

Building 1042	
Initial Sampling Event	Completed
E1	September 2018 (Fall)
Seasonal Sampling Event	Completed
E2	April 2019 (Spring)
E3	August 2019 (Summer)
E4	Scheduled - Winter 2019

For each sampling event, sub-slab soil gas samples were collected from four locations from within the building. Indoor air samples were collected at four locations corresponding to the soil gas sample locations, along with an outdoor air sample from the main air intake. The sampling locations are shown on Figure 5.5.10-2. Summary statistics and screening comparison results are presented for sub-slab soil gas on Table 5.5.10-A and indoor and outdoor air on Table 5.5.10-B. The analytical data is presented in Appendix A. Field sampling forms are provided in Appendix B.

The building survey completed before the initial sampling event can be found in Appendix D. Drains and other openings were screened with a PID and no soil gas entry points were identified. A chemical inventory was completed during the building survey and the chemicals found to be stored within the building are listed in the survey.

SUB-SLAB SOIL GAS RESULTS EVALUATION

Analytical results were evaluated based on methodologies presented in the 2018 Revised Vapor Intrusion Work Plan. The number of analytes detected above the sub-slab soil gas draft project-specific RIASL₁₂ or TSRIASL₁₂, if available, are discussed below by sampling event and shown on Table 1042-1:

1. During the initial event (Fall 2018), one analyte, 1,2,4-TCB, was detected above the draft project-specific RIASL₁₂ but less than the TSRIASL₁₂;
2. During the second event (Spring 2019), all results were less than screening levels; and
3. During the third event (Summer 2019), all results were again less than screening levels.

Table 1042-1. Summary of Sub-Slab Soil Gas Exceedances for Building 1042

Analyte (Sampling Event)	Detection Frequency	Measured Range of Detects ($\mu\text{g}/\text{m}^3$)	% Detections > Screening Level	Screening Level* ($\mu\text{g}/\text{m}^3$)
1,2,4-Trichlorobenzene (1)	50%	100 - 260	25%	200
1,2,4-Trichlorobenzene (2)	0%	ND	0%	200
1,2,4-Trichlorobenzene (3)	25%	32	0%	200

*Screening level provided is the draft project-specific RIASL₁₂.

EVALUATION OF VAPOR INTRUSION

Table 1042-2 summarizes the indoor air results relative to the sub-slab soil gas exceedances, since VI only potentially occurs if the analyte is present in both sub-slab soil gas and indoor air. Therefore, the table below provides the analytes detected above applicable screening levels in sub-slab soil gas as well as the corresponding indoor air sample results. The outdoor air sample results are also provided to determine if the analytes were present in indoor air due to migration from outdoor air.

Table 1042-2. Vapor Intrusion Evaluation for Building 1042

Analyte (Sampling Event)	Indoor Air Detection Frequency	Indoor Air Measured Range ($\mu\text{g}/\text{m}^3$)	Indoor Air Screening Level* ($\mu\text{g}/\text{m}^3$)	Outdoor Air Result ($\mu\text{g}/\text{m}^3$)
1,2,4-Trichlorobenzene (1)	0%	ND	6.2	ND
1,2,4-Trichlorobenzene (2)	0%	ND	6.2	ND
1,2,4-Trichlorobenzene (3)	0%	ND	6.2	ND

*Screening level provided is the draft project-specific RIASL₁₂.

All indoor air results are less than screening levels. While one detected concentration of 1,2,4-TCB exceeded the RIASL₁₂ in sub-slab soil gas, it was not detected in indoor air. In E1, naphthalene was detected in two samples in indoor air with one result above the RIASL₁₂ in indoor air. Naphthalene was

detected in E1 in one sample in sub-slab soil gas with a result less than screening levels. Naphthalene was not detected again in either media. All results in indoor air are < 1% of the Dow OEL. A full ND evaluation will be performed upon the completion of seasonal confirmation sampling in the 2020 CAIP.

CONCLUSIONS AND RECOMMENDATIONS

Based on the indoor air results, the VI pathway at Building 1042 is an insignificant exposure pathway based on current use. However, based on the sub-slab soil gas results and given the potential for future VI, Building 1042 has been placed in VI Path Forward Building Group 2, as lines of evidence indicate that VI is insignificant and the single indoor air exceedance of naphthalene was likely due to workplace chemical use. The final seasonal confirmation sampling event is scheduled for Winter 2019. A full evaluation will be presented in the 2020 CAIP.

5.6 Zone 3 Phase 2 Buildings

As discussed in Section 5.5, the 2018 Revised VI Work Plan included the sampling plans for priority buildings in Zone 3 that were initially referred to as Zone 3 Phase 1. As stated in the September 26, 2018 email to EGLE, only nine Zone 3 buildings were sampled in the fall of 2018 which were identified as Zone 3 Phase 1. The additional Zone 3 buildings presented in the workplan were reprioritized so that Dow could focus on additional investigations for priority buildings in Zones 1 and 2. The remainder of the buildings initially identified as Zone 3 Phase 1 became Zone 3 Phase 2 and were sampled in Fall 2019.

The Zone 3 geographical area contains 214 buildings and structures that were visited and categorized. Following the VI Categorization Flowchart (Figure 5-2), there are 21 buildings in Zone 3 Phase 2 categorized as priority buildings (Category 1 and 2). These buildings were identified for further evaluation, including the completion of a building survey and sampling activities.

Surveys for the Zone 3 priority buildings were completed from March 12, 2018 through May 4, 2018. As part of the surveys, a brief kick-off meeting was conducted with primary building contacts to complete the survey questionnaire and any obtained pertinent information, such as floor plans. After this meeting, the building survey was completed including gathering a chemical inventory (if one was not provided) and taking PID readings of the ambient air and drain features were recorded. The surveys for the Zone 3 Phase 2 priority buildings, which include the survey, floorplan, chemical inventory and PID readings, are found in Appendix D. The Zone 3 Phase 2 sampling plans were submitted in the 2018 Revised VI Workplan and resubmitted to EGLE (posted on the SharePoint site) in August 2019.

A recent review of the site demolition list indicated that a Zone 3 Phase 2 Category 1 building (Building 677) was listed for demolition. Therefore, this building has been recategorized and removed from VI evaluation.

The Zone 3 Phase 2 buildings were sampled in Fall 2019; however, the results were not available in time for evaluation in this report. Results from the Fall 2019 sampling efforts will be communicated to EGLE during a monthly Corrective Action meeting in early 2020, unless results warrant notification and expedited reporting. The Zone 3 Phase 2 buildings contains 8 Category 1 buildings and 13 Category 2 buildings and are summarized below.

5.6.1 Building 734

Building 734 (with a footprint of 16,233 ft²) was built in the late 1950s to early 1960s and is located in the northeastern quadrant of the Midland facility. Building 734 also has a basement with one-story above grade. The footprint of the basement is approximately 11,278 ft². Approximately 4,956 ft² of the floor above grade is not underlain by basement; however, this area is unoccupied and was previously associated with the recently demolished structure to the west, Building 1261.

The depth of the basement is approximately 12-15 ft below grade. The foundation walls are made of cinder block, which are painted or covered with drywall in some areas, and the basement floor is concrete, which is typically covered in tile or carpet in most areas. The basement area is unoccupied with no future plans of occupancy, but has office space, bathrooms, and labs. There is a sump pit with two sump pumps located in the northwestern mechanical room in the basement, and the sump had water in it at the time of the survey. There is also an elevator in this building in the southeastern corner.

The first floor of the building consists of offices and labs. There is a bay door located on the south side of the structure and is only opened for the occasional delivery. There are two outdoor air intakes; one of which is located on the west side of the building on ground level, and the other is on the roof on the south side of the building. The building has one building chiller with a chilled water loop to three air-handling units that have steam coils, meaning the building is heated via steam radiation and cooled via central AC. The outdoor ground cover around the building is predominantly asphalt with some gravel in place where Building 1261 formerly stood.

No PID detections were observed in the ambient air throughout the building or from any drains or sumps identified at the time of the survey.

5.6.2 Building 938

Building 938 was built in the 1960s and is located in the northwestern quadrant of the Midland facility. This building contains a permit writing area, control room area, kitchen/break area, switch room, mechanical room, bathroom, and a lab. The building is a one-story structure of slab-on-grade construction with no elevators or basement and has a footprint of approximately 2,758 ft².

The building's heat is produced via steam radiation. Two AC units exist for this building, with one used as a backup. The intake for this building is located on the north side of the building near the northwestern corner at ground level. No bay doors/overhead doors exist on this structure. The immediate area outside of the building is covered by asphalt or concrete. Occupants use the washers and dryers at Building 298 and a contracted weekly laundry service.

No PID readings were detected in the ambient air or in any drain-like features observed in the building.

5.6.3 Building 990

Building 990 was built in in the 1950s-1960s and is located in the northeastern quadrant of the Midland facility. The building consists of Trinseo office space, conference rooms, a mod control room, kitchen/break area, and bathrooms. The structure is a one-story slab-on-grade construction with no basement or elevators and has a footprint of 7,968 ft².

The building is centrally heated and cooled with the AC being pulled from a nearby cooling tower and the heating produced via hot air circulation. The building has no bay doors and the outdoor ground cover is asphalt.

No PID detections were observed in the ambient air throughout the building or from the drains observed in the men and women's bathrooms at the time of the survey.

5.6.4 Building 1018

Building 1018 was constructed in the early 1970s and is located in the northwestern quadrant of the Midland facility. This building primarily contains office space, locker rooms (which have washers and dryers), a kitchen/break room, and an area referred to as the "old lab space." The building is a one-story structure slab-on-grade construction with no basement or elevator and has a footprint of approximately 4,992 ft².

The entire floor of the building is either concrete covered by paint or an epoxy coating. The building is heated via hot air circulation (although electric baseboards are present, they are now defunct), and cooled via central AC through one unit. An outdoor intake exists on the north side of the building connecting to the HVAC room, although the intake for the air handler is located inside the HVAC room and is not directly connected to the outside intake. This building has no bay doors/overhead doors and the ground cover surrounding the building is asphalt. Note that although the building has washer and dryers, some occupants use a weekly contracted laundry service for some items.

PID readings were detected in the ambient air in the HVAC room and the janitor's closet at 0.1 ppm. PID readings were also detected in the drains in the men and women's locker room (0.1 ppm), the janitor's closet (3.1 ppm), and the drain in the HVAC room (150 ppm).

5.6.5 Building 1385

Building 1385 (an Electronic Materials Building) was constructed in 1993-1994 and is located in the northwestern quadrant of the Midland facility. This building is a one- to two-story structure of slab-on-grade construction with no basement or elevator (although one of the process areas has a lift) and a footprint of approximately 13,916 ft². This building contains office space, locker rooms, lab space, warehouse space, and process areas (the process areas are roughly 2,902 ft²). There are sumps located in the process areas that lead to a fire pit.

The building is heated via hot air circulation, and two central AC units cool the building. The bathrooms have ventilation fans, and the outside air intake for the building is located on the rooftop facing north. There is one overhead/bay door that is rarely open with the exception of moving equipment and/or materials in and out of the building. The surrounding ground cover outside the building is predominantly asphalt with large gravel/stone on the south side near the railroad tracks. Building occupants use a contracted laundry service.

No PID detections were observed in the ambient air throughout the building, but a PID detection of 7.7 ppm was observed in the drain in the women's bathroom/locker room.

5.6.6 Building 439/T-1411

The combined 439/T-1411 trailers were put in place sometime between 2000-2010 and are located in the northwestern quadrant of the Midland facility. The two trailers are connected via an enclosed corridor. These trailers contain offices, a library, break room/kitchen area, and bathrooms. The occupants in this building support the activities conducted at Building 1385 located immediately to the southeast. The trailers, combined, are a one-story structure with a crawl space underneath and have a footprint of approximately 4,199 ft². The trailers are heated by electric baseboard and have two central AC units located on the west side of T-1411. The outdoor ground cover is predominantly asphalt. No PID readings were detected in the ambient air or from any drain features in the trailers at the time of the survey.

5.6.7 Building 732/1300

Buildings 732 and 1300 have been combined as they are connected to each other with no way of closing off the noted connections. These buildings are located in the northeastern quadrant of the Midland facility with a combined footprint of 22,660 ft². The 732 portion of the building is a warehouse with a shop area and was built in the 1960s. The 1300 portion of the building contains office space on the eastern end of the building, and lab space, Research & Development (R&D) space, and some warehouse space in the remainder of the building and was built in 1987. The entire 732/1300 structure has six bay doors that are open on occasion for moving materials in and out and are open more frequently during the warmer months (particularly the doors off of the 732 portion). The ground cover around the outside of these buildings consists of asphalt, but an atrium area exists between the two connecting corridors for 732 and 1300 and has trees and other vegetation present.

The 732/1300 structure are a slab-on-grade construction with no basement and no elevator. The air is heated via hot air circulation in the 1300 portion, and is heated via steam radiation in the 732 portion. The air is cooled in the 1300 portion via two large central and three individual AC units. Exhaust mechanical fans are present in the 732 portion of the structure. An outside air intake is located on the south side of the 1300 portion of the building near the southeast corner. A second intake is located inside the 1300 portion of the structure in the laundry area. There are trenches throughout the 1300 portion of the building that are used for rinsing down equipment between coating batches. The concrete floor in the main R&D portion of 1300 is painted. These trenches are connected to the sewer system which drains to the Midland facility WWTP.

A propane-fueled jeep/fork truck is frequently used in the 732 portion of this building. The laundry area is located on the southern side of the 1300 portion of the building, and the concrete flooring in the R&D/lab portion of 1300 is painted.

PID detections were observed in the ambient air in the southeastern bathroom (0.1 ppm), the laundry area (0.6-0.8 ppm), the large R&D area (0.1-0.7 ppm), the 732 warehouse (0.1 ppm), the southeastern lab area (0.1 ppm), and the office areas (0.1 ppm). PID detections were observed in the drains in the southeastern HVAC area (20.9 ppm), the drain in the southeastern bathroom (0.3 ppm), and the drain in the southeastern lab area (5.5 ppm).

5.6.8 Building 759/1350

Building 759/1350 was built in 1991-1992 and is located in the northeastern quadrant of the Midland facility. The 759 portion of this building is predominantly unoccupied office and shop space; however, it has been combined with 1350 as these two structures share a wall with an opening between the two buildings. Additionally, occupants of 1350 frequently walk through portions of 759 to access process areas located to the west of the combined structure. This building contains office space, conference rooms, laundry areas, kitchen/break rooms, a control room, multiple labs, unoccupied shop space, and locker rooms. This building is a one-story slab-on-grade structure with no basement or elevator and has a combined footprint of 31,753 ft².

The surrounding outdoor ground cover for this building is asphalt. Both parts of the building are heated via hot air circulation. Two mechanical rooms are located at the northeast corner and southern side of the 1350 portion of the structure and each room contains air-handling units that are associated with outdoor intakes on either the side of the building or the roof in the noted areas. The 759 portion has an HVAC unit located in the unoccupied instrument shop area with an internal intake. Four overhead/bay doors are located on the 759 portion of the structure. One of the bay doors located near the northwestern corner is open the majority of the time. Occupants of this combined building use washers and dryers located throughout the building.

No PID detections were observed in the ambient air or in any of the drain features observed in this building at the time of the survey.

5.6.9 Building 49

Building 49 was constructed prior to 1938, per aerial photography, and is located in the northwestern quadrant of the Midland facility (Figure 5.6.9-1). Roughly 75% of the building is a large shop area broken into an auto, value, and machine shop. The western 25% of the building consists of office space. There is an office annex located on the south-central side of the shop area. There is also a small warehouse structure located on the southeast corner of the building. Approximately 40 to 50 people occupy the building. Most occupants work four 10-hour shifts Monday through Thursday, but some others work five 8-hour shifts Monday through Friday. On occasion, some occupants may work overtime.

The building is a slab-on-grade construction with no basement and had a footprint of 60,851 ft². The western office area of the building is four stories. The shop area is roughly two to three stories tall, and the southern office annex is one-story. Most of the office areas throughout this building have an epoxy coating over the concrete floor. There are two elevators in this building: one is located on the south side of the building near the wall shared with the office portion and shop portion of the building, and the other is on the north side of the building.

The building is heated via steam radiation. There are three central AC units: one for the western office areas, one for the office annex, and one for the second-story/deck lunch room located on the north side of the shop. Two large intakes are located on the south side of the building, with an additional one located on the north side of the building on the roof. There are also multiple vents located on the northern and eastern sides of the structure. There are five bay doors that are normally open during the summer and

are closed as much as possible during the winter. The ground cover outside of the building is a mixture of grass and asphalt. Occupants use washers and dryers found in the locker room and on the north central side of the large shop area.

PID detections were observed in the ambient air at:

- The eastern portion of the machine shop: Up to 0.9 ppm;
- The hallway around the seal room: 0.1 ppm;
- The seal room: 0.2-0.3 ppm;
- The washdown area: 0.4-0.6 ppm;
- To the east of the entryway of the southeastern break room: 0.2-4.6 ppm;
- The southeastern warehouse: 0.1-1.1 ppm;
- The value/auto shop area: 0.4 ppm;
- Laundry area: 0.3 ppm;
- Machine shop office: 0.8 ppm; and
- Western part of the machine shop: 0.1-0.6 ppm.

PID detections were observed in:

- The drain just north of the southeastern warehouse: 1.2 ppm;
- The drain in the women's locker room in the office portion of the building: 4.3 ppm;
- The drain in the men's bathroom in the office portion of the building: 0.2 ppm; and
- The drain in the machine shop office's bathrooms: 0.1 ppm.

EXPEDITED REPORTING

An EBS was provided in December 2019 based on the Summer 2019 sampling event and EGLE's request for expedited reporting if an indoor air result exceeds the TSRIASL₁₂. An email notification was provided in October 2019. Seasonal confirmation sampling will be initiated for both sub-slab soil gas and indoor air. Dow has scheduled Building 49 for further investigation activities in early 2020 and results were presented to EGLE during the monthly Corrective Action Status meeting in October 2019. The findings of the EBS are discussed in later sections.

The EBS concluded that the PCE and trans-1,2-DCE detected in the indoor air at Building 49 is due to indoor sources and is not attributable to VI. The indoor air results suggest a common source, such as work within the pump room, scale shop, seal room, machine shop, and motor/valve shop involving degreasers or other products. During a preliminary further investigation walk-through, the field team identified 44 cans of PCE degreaser throughout the shop areas. IRAs are not necessary to address the detections of PCE and trans-1,2-DCE in indoor air at Building 49; however, seasonal confirmation sampling will occur and the building has been scheduled for further investigation activities.

DATA SUMMARY

Building 49 has undergone the initial sampling event. The analytical results from each of the sampling events were compared to the June 22, 2018 EGLE draft project-specific 12-hour Soil Gas screening values and AACs (draft project-specific RIASL₁₂ and TSRIASL₁₂, if available).

Building 49	
Initial Sampling Event	Completed
E1	August 2019 (Summer)

For each sampling event, sub-slab soil gas samples were collected from 25 locations from within the building. Indoor air samples were collected at 25 locations corresponding to the soil gas sample locations, along with an outdoor air sample from the main air intake. The sampling locations are shown on Figure 5.6.9-2. Summary statistics and screening comparison results are presented for sub-slab soil gas on Table 5.6.9-A and indoor and outdoor air on Table 5.6.9-B. The analytical data is presented in Appendix A. Field sampling forms are provided in Appendix B.

The building survey completed before the initial sampling event can be found in Appendix D. Drains and other openings were screened with a PID and no soil gas entry points were identified. A chemical inventory was completed during the building survey and the chemicals found to be stored within the building are listed in the survey.

SUB-SLAB SOIL GAS RESULTS EVALUATION

Analytical results were evaluated based on methodologies presented in the 2018 Revised Vapor Intrusion Work Plan. During the initial event (Summer 2019), seven analytes were detected above the draft project-specific RIASL₁₂ and each analyte had at least one result that also exceeded the TSRIASL₁₂. The results for these seven analytes are summarized in Table 49-1 below.

Table 49-1. Summary of Sub-Slab Soil Gas Exceedances for Building 49

Analyte (Sampling Event)	Detection Frequency	Measured Range of Detects ($\mu\text{g}/\text{m}^3$)	% Detections > Screening Level	Screening Level* ($\mu\text{g}/\text{m}^3$)
1,1-Dichloroethane (1)	100%	5.1 - 42,000	16%	2,500
1,1-Dichloroethene (1)	60%	11 - 100,000	8%	20,000
1,4-Dioxane	8%	31 - 1,200	4%	800
Chloroform (1)	92%	7 - 4,100	64%	170
cis-1,2-Dichloroethene (1)	72%	16 - 51,000	20%	820
Tetrachloroethene (1)	100%	170 - 230,000	44%	2,700
Trichloroethene (1)	100%	5.6 - 120,000	72%	130

*Screening level provided is the draft project-specific RIASL₁₂.

EVALUATION OF VAPOR INTRUSION

Table 49-2 summarizes the indoor air results relative to the sub-slab soil gas exceedances, since VI only potentially occurs if the analyte is present in both sub-slab soil gas and indoor air. Therefore, the table below provides the analytes detected above applicable screening levels in sub-slab soil gas as well as the corresponding indoor air sample results. The outdoor air sample results are also provided to determine if the analytes were present in indoor air due to migration from outdoor air.

Table 49-2. Vapor Intrusion Evaluation for Building 49

Analyte (Sampling Event)	Indoor Air Detection Frequency	Indoor Air Measured Range ($\mu\text{g}/\text{m}^3$)	Indoor Air Screening Level* ($\mu\text{g}/\text{m}^3$)	Outdoor Air Result ($\mu\text{g}/\text{m}^3$)
1,1-Dichloroethane (1)	12%	0.24 - 0.39	74	ND
1,1-Dichloroethene (1)	12%	0.084 - 0.49	620	ND
1,4-Dioxane	0%	ND	24	ND
Chloroform (1)	32%	0.17 - 3.8	5.2	ND
cis-1,2-Dichloroethene (1)	12%	0.16 - 0.38	24	ND
Tetrachloroethene (1)	100%	1.8 - 22,000	82	4.4
Trichloroethene (1)	16%	0.26 - 0.9	4	ND

*Screening level provided is the draft project-specific RIASL₁₂.

PCE and trans-1,2-DCE were the only analytes at Building 49 with detected results above the indoor air TSRIASL₁₂ (82 $\mu\text{g}/\text{m}^3$ for PCE and 790 $\mu\text{g}/\text{m}^3$ for trans-1,2-DCE). PCE exceeded the TSRIASL₁₂ at 10 of 25 sample locations. The 10 indoor air sample locations with PCE exceedances were located mostly in the east side of the building (in the seal room, pump room, and scale shop) and in various locations in the machine shop, as well as the machine shop office and in the motor/valve shop. Of the 10 indoor air PCE TSRIASL₁₂ exceedances, seven are co-located with corresponding sub-slab soil gas PCE TSRIASL₁₂ exceedances (at locations 02, 03, 05, 06, 08, 10, and 16). Figures 49-1 and 49-2 present the results for PCE and trans-1,2-DCE, respectively.

Trans-1,2-DCE had a single indoor air TSRIASL₁₂ exceedance at one of 25 sample locations (in the pump room in the east side of the building) and all sub-slab soil gas results were below TSRIASL₁₂.

Sub-slab soil gas TSRIASL₁₂ exceedances were observed for 1,1-DCA, 1,1-DCE, chloroform, cis-1,2-DCE, PCE, and TCE; however, the only chemical with corresponding indoor air exceedances was PCE.

To demonstrate the level of VI that might be occurring in the building, data for TCE, in addition to PCE and trans-1,2-DCE, is included in Table 49-3. As shown in Table 49-3, 12 sub-slab soil gas TCE results are above the TSRIASL₁₂ (400 $\mu\text{g}/\text{m}^3$); however, TCE was not detected at concentrations above screening levels in indoor air. This analyte is well suited for use in the development of a building-specific attenuation factor (α) given the detected sub-slab soil gas values and the minimal contributions from indoor sources or from outdoor air. TCE was detected in 48% of sub-slab soil gas samples with an average concentration of 8,269 $\mu\text{g}/\text{m}^3$ and a maximum concentration of 120,000 $\mu\text{g}/\text{m}^3$. The analyte was detected in only four of 25 indoor air samples (16%), with a maximum concentration of 0.9 $\mu\text{g}/\text{m}^3$. Assuming that VI is the only source, the building-specific attenuation factor (α) for TCE is 7.5E-06. Applying this attenuation factor to the maximum PCE sub-slab soil gas result indicates that any VI contribution to the measured indoor air values is < 2 $\mu\text{g}/\text{m}^3$ (i.e., 230,000 $\mu\text{g}/\text{m}^3 \times 0.0000075 = 1.73 \mu\text{g}/\text{m}^3$). Therefore, > 99% of the PCE detected in indoor air is present due to sources other than VI.

As discussed above on October 10, 2019, the mobile-GC field team was able to complete a preliminary further investigation walk-through and identified 44 aerosol cans of PCE degreaser throughout the shop areas, most of which were open and appeared to have been recently used. The PID readings ranged from 50 - 400 ppbv in the breathing zone of the shop areas and machine shop offices. Levels in the ppm range were detected above rubber mats placed below work benches where the PCE degreasers were actively used. The south offices had PID readings between 10 - 50 ppbv and the vacant offices to the west all had 0 ppbv readings. The preliminary conclusion is that the majority of the PCE concentrations detected in indoor air at Building 49 is due to active workplace chemical use. The mobile-GC field team will continue the investigation into this building the next time they return to the site.

Furthermore, there is additional evidence that indicates the presence of indoor sources are not related to VI:

- Forty-four open cans of aerosol PCE degreaser were identified throughout the shop areas of the building and they appeared to have been recently used.
- PCE was detected in the outdoor air sample at 4.4 $\mu\text{g}/\text{m}^3$. The presence of PCE in outdoor air is indicative of a source of PCE not related to VI.
- The highest PCE concentrations in the indoor air occurred at locations 49-IA-03 and 49-IA-04 (Figure 49-1). At 49-IA-04 the concentration of PCE in indoor air was more than 36 times higher than the concentration of PCE detected in the sub-slab sample, indicating that VI at this location is not the cause of the elevated indoor air concentration. The data suggest that VI is not the main source of any PCE detected in indoor air.
- There is weak spatial correlation between sub-slab soil gas and indoor air PCE and trans-1,2-DCE concentrations. The concentration of trans-1,2-DCE at indoor air sampling location 49-IA-04 is 40 times higher than the corresponding sub-slab soil gas concentration, indicating a source of trans-1,2-DCE not related to VI. The building survey found that trans-1,2-DCE-containing material were present in the pump room (the location of sample 04), indicating that indoor chemical use is responsible for the elevated trans-1,2-DCE concentration.
- The highest PCE concentrations in the indoor air occurred in the pump room and scale shop in the northeast corner of the building. The building survey found that PCE-containing materials are stored in both the pump room and scale shop in the northeast corner of the building. The correlation of the PCE-containing materials and the relatively high PCE concentrations in indoor air suggest that the detected values are the result of the indoor emission sources.

The maximum indoor air result of PCE detected in Building 49 is 22,000 $\mu\text{g}/\text{m}^3$, which is 32% of the Dow Industrial Hygiene (IH) OEL. The maximum indoor air result of trans-1,2-DCE detected in Building 49 is 2,500 $\mu\text{g}/\text{m}^3$, which is 0.3% of the Dow IH OEL.

Table 49-3. Comparison of Results for TCE, PCE and trans-1,2-DCE

Sample ID	Measurement Result ($\mu\text{g}/\text{m}^3$)					
	TCE Indoor Air	TCE Sub-Slab Soil Gas	PCE Indoor Air	PCE Sub-Slab Soil Gas	Trans-1,2-DCE Indoor Air	Trans-1,2-DCE Sub-Slab Soil Gas
49-OA-1	<0.16	--	4.4	--	<0.6	--
49-xx-1	<0.16	38	2.4	290	<0.6	<3.4
49-xx-2	<0.68	600	430	3,500	47	<7.6
49-xx-3	<1.7	330	1,100	8,700	140	<21
49-xx-4	<48	5.6	22,000	600	2,500	62
49-xx-5	<0.36	480	240	16,000	25	<45
49-xx-6	<0.2	4,200	130	89,000	12	<65
49-xx-7	<0.2	460	39	3,100	3.5	<30
49-xx-8	<0.2	13,000	98	220,000	9	160
49-xx-9	<0.18	6	42	170	3.8	<3.1
49-xx-10	<0.21	390	95	35,000	9	<63
49-xx-11	<0.2	520	38	1,700	3.6	10
49-xx-12	<0.19	410	100	1,400	9.7	29
49-xx-13	0.56	490	82	1,700	7.3	7.9
49-xx-14	<1.9	320	98	1,500	7	15
49-xx-15	<0.16	52	56	840	5.3	11
49-xx-16	0.26	350	120	6,800	9.8	330
49-xx-17	<0.17	89	4.1	1,200	<0.61	<3.4
49-xx-18	<0.17	9.7	4.3	770	<0.62	<3.4
49-xx-19	<0.18	370	4.5	1,100	<0.65	12

Table 49-3. Comparison of Results for TCE, PCE and trans-1,2-DCE (Continued)

Sample ID	Measurement Result ($\mu\text{g}/\text{m}^3$)					
	TCE Indoor Air	TCE Sub-Slab Soil Gas	PCE Indoor Air	PCE Sub-Slab Soil Gas	Trans-1,2-DCE Indoor Air	Trans-1,2-DCE Sub-Slab Soil Gas
49-xx-20	<0.17	190	1.9	1,800	<0.61	<7.8
49-xx-21	<0.17	27	1.9	2,300	<0.63	<10
49-xx-22	<0.2	500	1.9	1,800	<0.72	19
49-xx-23	<0.16	5,900	1.8	28,000	<0.59	140
49-xx-24	0.9	120,000	3.8	230,000	<0.67	1,900
49-xx-25	0.6	58,000	3.1	170,000	<0.64	750
Minimum	<0.16	5.6	1.8	170	<0.59	<3.1
Maximum	0.9	120,000	22,000	230,000	2,500	1,900
Maximum	0.9	120,000	22,000	230,000	2,500	1,900
Attenuation Factor (based on maximum)	7.5E-6		0.096		1.32	

Notes:

< - Non-detect at the reporting limit (RL).

ID - Identification.

TCE Indoor Air TSRIASL₁₂ - 12 $\mu\text{g}/\text{m}^3$.TCE Sub-Slab Soil Gas TSRIASL₁₂ - 400 $\mu\text{g}/\text{m}^3$.PCE Indoor Air TSRIASL₁₂ - 82 $\mu\text{g}/\text{m}^3$.PCE Sub-Slab Soil Gas TSRIASL₁₂ - 2,700 $\mu\text{g}/\text{m}^3$.Trans-1,2-DCE Indoor Air TSRIASL₁₂ - 790 $\mu\text{g}/\text{m}^3$.Trans-1,2-DCE Sub-Slab Soil Gas TSRIASL₁₂ - 26,000 $\mu\text{g}/\text{m}^3$.**Shaded** - Value greater than TSRIASL₁₂.

The indoor air values were not adjusted for the outdoor air results.

Maximum attenuation factor based on maximum/maximum.

CONCLUSIONS AND RECOMMENDATIONS

The EBS concluded that the PCE and trans-1,2-DCE detected in the indoor air at Building 49 is due to indoor sources and is not attributable to VI. The indoor air results suggest a common source, such as work within the pump room, scale shop, seal room, machine shop, and motor/valve shop involving degreasers or other products. During a preliminary further investigation walk-through, the field team identified 44 cans of PCE degreaser throughout the shop areas.

Based on the findings presented above and the indoor air results, it appears that routine workplace chemical use is likely the source of the indoor air exceedances in Building 49 and the contribution of VI to the measured indoor air concentrations is insignificant. However, based on the sub-slab soil gas and indoor air results and given the potential for future VI, Building 49 has been placed in VI Path Forward Building Group 4A due to a lack of correlated sample sub-slab soil gas and indoor air exceedances and other lines of evidence indicate that VI is insignificant and indoor air exceedances are likely due to workplace chemical use. Seasonal confirmation sampling will be performed and a further investigation will be completed for Building 49. A full evaluation will be presented in the 2020 CAIP.

Figure 49-1



Legend

- 49-## Sub-slab/Indoor Air Location
- Exceeds TSRIASL₁₂
- Exceeds Dow OEL

Media	COC	RIASL ₁₂	TSRIASL ₁₂	OEL
Soil Gas	PCE	2,700	2,700	--
Indoor Air	PCE	82	82	67,800

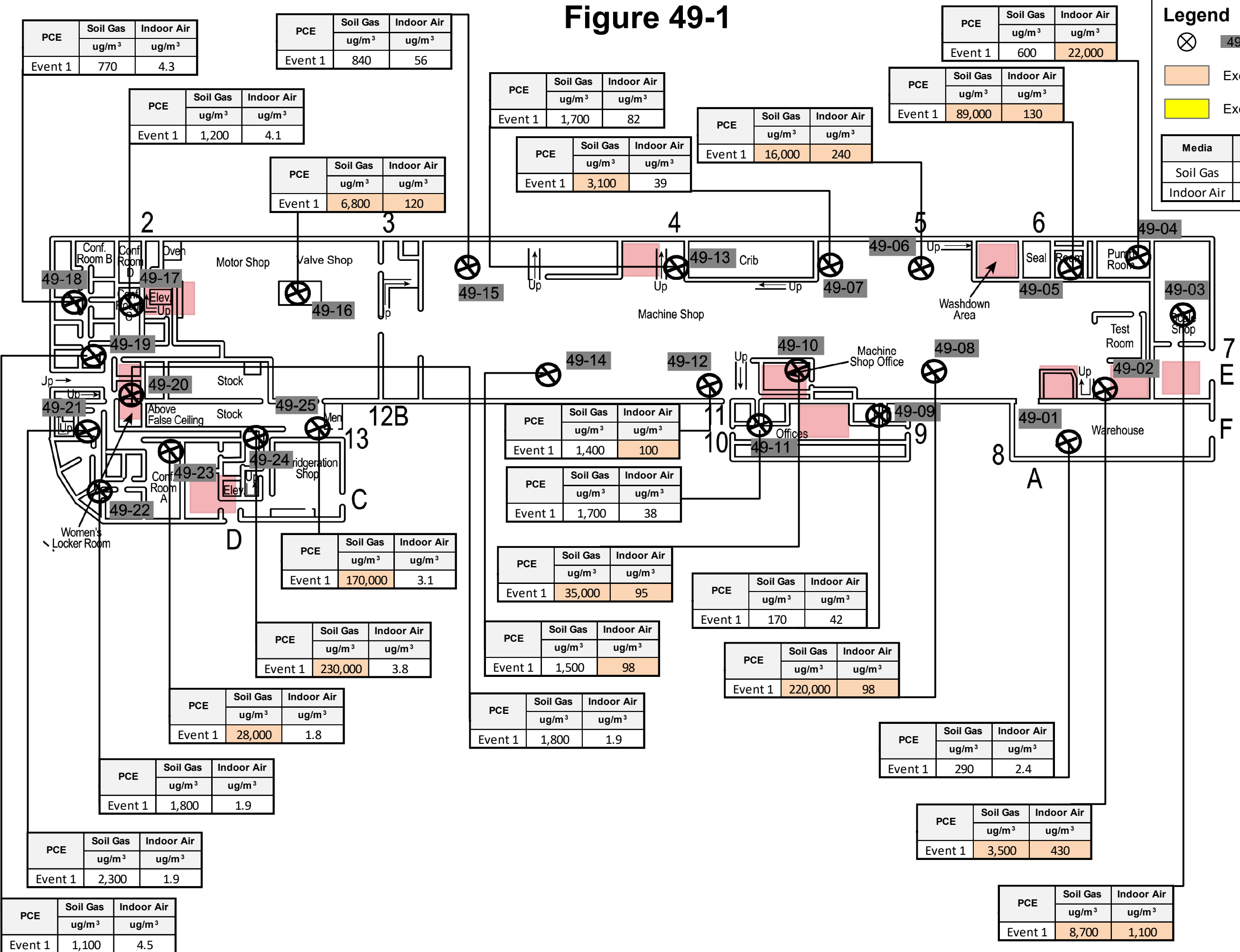

Notes:
 All units ug/m³
 Initial Sampling Event (1) = August 2019
 Intakes for first floor are located on the S side of the building near Door D and Doors 8 and 9

PCE	Outdoor Air Sample
ug/m ³	ug/m ³
Event 1	4.4

Sub-slab Soil Gas and Indoor Air Results for Tetrachloroethene Zone 3 Phase Sampling Event 1 Building 49



Figure 49-2



Legend

- ⊗ 49-## Sub-slab/Indoor Air Location
- Exceeds RIASL₁₂ Only
- Exceeds TSRIASL₁₂
- Exceeds Dow OEL

Media	COC	RIASL ₁₂	TSRIASL ₁₂	OEL
Soil Gas	TCE	130	400	--
Indoor Air	TCE	4	12	26,850

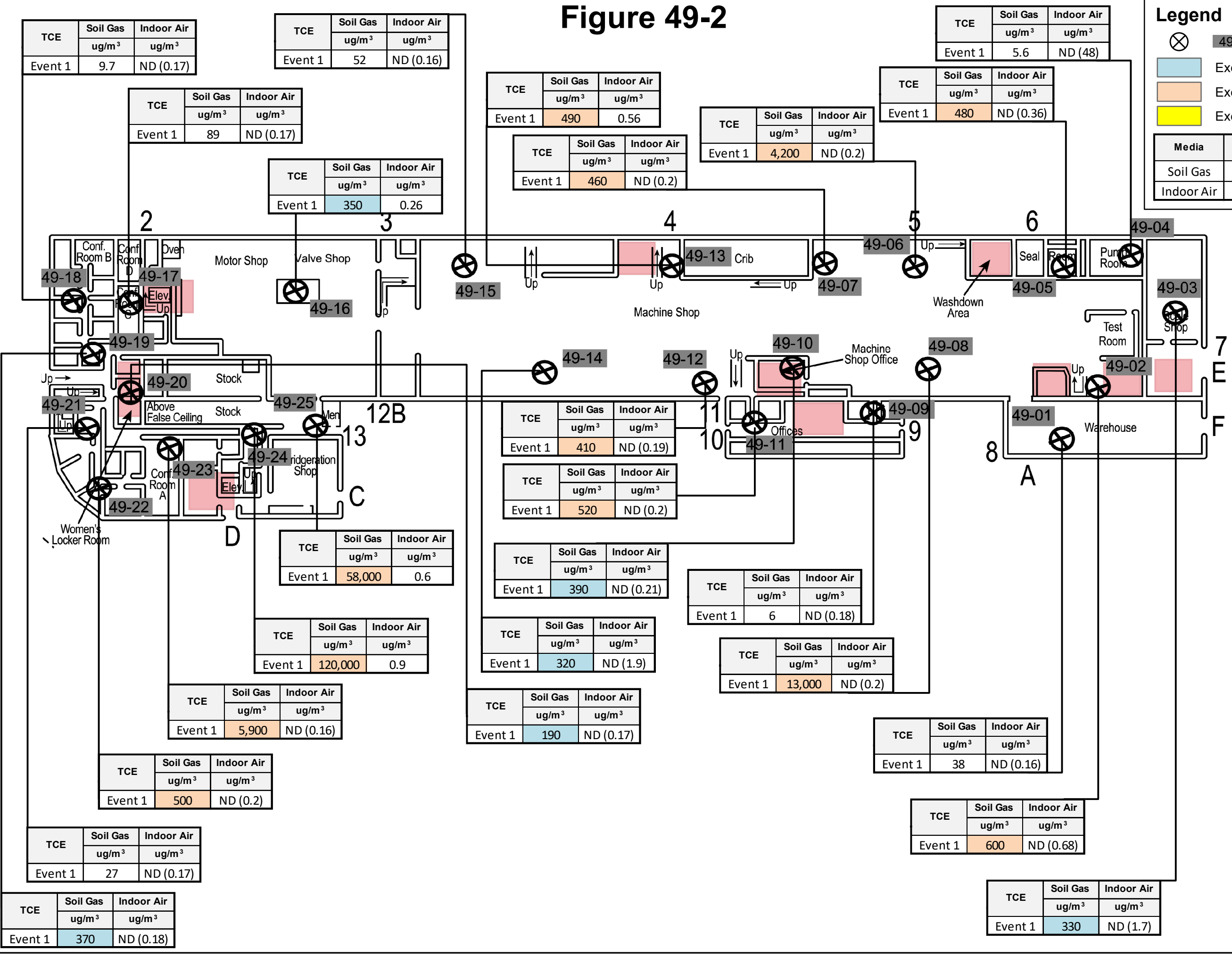

Notes:

All units ug/m³

Initial Sampling Event (1) = August 2019

Intakes for first floor are located on the S side of the building near Door D and Doors 8 and 9

TCE	Outdoor Air Sample
Event 1	ND (0.16)

Sub-slab Soil Gas and Indoor Air Results for Trichloroethene Zone 3 Phase Sampling Event 1 Building 49



5.6.10 Building 146

Building 146 is predominantly a large enclosed area with rail lines running into it with shop benches located to the side of the rail lines. Small walled-off areas in this structure are located in the northern, western, and southern corners. These areas contain offices, bathrooms, and storage areas, respectively. This two-story structure was built prior to 1938 per aerial photography and is located in the northwestern quadrant of the Midland facility. The building is slab-on-grade construction with no basement and no elevators.

The building has seven bay doors, six of which are located on the southeastern side and one is located on the southwestern side. These doors are open more often during the summer months and are closed as much as possible during the winter months. The office and bathroom areas are cooled by a central AC unit and individual AC unit, respectively. An outdoor intake for the northern office area is located on the northeast side of the building. There are mechanical fans located throughout the main open area of the structure. The office and bathroom areas are heated by electric baseboards or mounted heaters. The surrounding ground cover outside the building is gravel/grass on the northeast, southeast, and southwest sides of the building; and gravel/asphalt on the northwest side of the building. Occupants either use a contracted weekly laundry service or washers and dryers that are in the men's locker room located on the second floor deck.

At the time of the survey, PID detection of 0.3 ppm was observed in the drain found in the women's bathroom; and PID detections ranging from 0.1, 0.2, and 0.5-0.6 ppm were seen in the ambient air in the main railcar area, the women's bathroom, and chemical storage room, respectively.

5.6.11 Building 180

The entire Building 180 structure is located in the southwestern quadrant of the Midland facility. The railcar area was built prior to 1940, and the office annex was built in the 1970s. This building contains a large enclosed area that has railroad tracks within it for the purpose of maintaining and washing rail cars. The office/shop annex is attached to the southwest side of this building. The building is a slab-on-grade construction with no basement or elevator and has a footprint of 23,031 ft². The office annex is one-story tall, and the rail car area is approximately two stories tall. The kitchen floor in the office annex is covered in an epoxy coating.

The office annex is heated via forced hot air circulation and is cooled via a central AC unit located on southern side of the building. The outside air intake for the office annex is located above the bay door to the HVAC room. The entire structure has 11 bay doors, nine of which are on the railcar area of the building, one is located on the south side of the shop, and one is located on the western side of the HVAC room. These bay doors are opened more than they are closed during the summer months and vice versa for the winter months. The surrounding outdoor ground cover is predominantly gravel with some grass with the exception of asphalt located to the southwest. Occupants either use a contracted weekly laundry service or use the washers and dryers located in the men's locker room.

PID readings collected during the survey showed no detections of VOCs in the ambient air or from any drain feature observed.

5.6.12 Building 298

Building 298 is roughly 75-80 years old and is located in the northeastern quadrant of the Midland facility. This building contains offices, conference rooms, kitchen/break rooms, bathrooms, a lab and laundry room (on the second floor), and a large shop area in the eastern half of the building. Half of the building is one-story, and the other half is two stories. The building is a slab-on-grade construction with no basement or elevator and has an approximate footprint of 14,034 ft².

The structure is heated via steam radiation and is cooled via a combination of three central and five individual AC units. The three central AC units have intakes located on the west side and north side of the building. The building has two bay doors off of the shop portion of the building that are open frequently during the summer but are otherwise closed. The surrounding outdoor ground surface of the building is covered with either asphalt or concrete. On occasion, a fork truck or golf cart is stored in the shop portion of the building. Although laundry facilities are present in this building, a contracted weekly laundry service is also available.

No PID detections were observed in the ambient air throughout the building or from any drain-like features observed during the survey.

5.6.13 Building 374

Building 374 was built in the 1950s and is located in the northeastern quadrant of the Midland facility. Building 374 is predominantly process area used to make and package Methocel, but small support office areas, break rooms, shop space, and warehouse exist in the southern and southeastern portion of the building. Building 375 is connected to the west side of the southern warehouse portion of Building 374 via a large overhead door, but it is a process area. The structure ranges anywhere from one-story to seven stories in height and has a footprint of approximately 64,809 ft². Roughly 36,603 ft² of the footprint is process area that ranges from being completely enclosed to having partial walls. The portion of the structure containing non-process areas (offices, warehouse space, etc.) is 28,206 ft². The building is a slab-on-grade construction with no basement and a freight elevator is located in the process area.

Building 374 has eight bay/overhead doors that are open for roughly half the year for delivery and ventilation purposes. Much of the building is heated via steam radiation, but some of the enclosed parts are heated via hot air circulation. There are three AC units, one of which is an individual unit for the lunch room area in the warehouse. Intakes for the central units are located on the roof. The surrounding outdoor ground cover is either asphalt or gravel. Occupants use the laundry services via Building 1131. Propane-fueled fork trucks and gasoline-fueled power washers are used in the warehouse portion of the building.

No PID detections were observed in the ambient air throughout the building; however, PID detections were observed from the drains located in a janitor's closet (1.2 ppm) and the men's bathroom (0.5 ppm).

5.6.14 Building 464

Building 464 was built in the 1950s (per aerial photography), is located in the northeastern quadrant of the Midland facility and has a footprint of approximately 30,103 ft². It is a two-story structure that contains offices, a large break room, shop areas, and warehouse space on the first floor and predominantly office space on the second floor. The building is a slab-on-grade construction with no basement and no elevator. The second floor office area is located in the northeastern quadrant of the building. The remaining quadrants consist of a warehouse area that has been broken up to various storage areas, offices, or shop space.

The building is heated via steam radiation. Central AC units are located on the east side of the building for the second floor and in the north central portion of the building for the instrument shop and office area. Outside intakes are located on the east side of the second-story roof and on the north-central side of the building. Five overhead/barn doors exist on the structure that are typically closed during the winter months but are often open during the summer months. Propane-fueled fork trucks and large diesel-fueled JLG lifts are driven around and into the building on a frequent basis. The outdoor ground cover surrounding the building is asphalt. Occupants of the building use washers and dryers located on the second floor of Building 743.

PID detections of 0.1 ppm, 0.3 ppm, and 0.5 ppm were seen in drains found in the east side of the large break room, the vacant offices on the east side of the first floor, and a drain found in the instrument shop,

respectively. PID detections of 0.1-1.3 ppm were observed in the grated chemical storage room in the southwest corner of the building, the general western shop area, and the northwestern parts room. The highest readings were seen in the western shop area and northwestern part room as recently used parts were temporarily being stored in the area and were being removed later in the day of the survey.

5.6.15 Building 638

Building 638 was built in 1950 and is located in the northeastern quadrant of the Midland facility with a footprint of approximately 6,619 ft². This building consists of a large shop area that takes up the western 75% of the building and the eastern 25% is made up of locker rooms/bathrooms, office space, and a kitchen/break room. Building 638 is predominantly used by a contractor on site (JE Johnson). This building is a one-story slab-on-grade construction with no basement or elevator and has one bay door on the south side of the building. However, the ceiling height in the shop portion is roughly two stories tall and has a small upper deck located over part of the shop area. The bay door is closed primarily during the winter months but is open during the summer months when people are working in the shop area. The building is heated via steam radiation, and individual AC units are used for the offices and kitchen/break room area. Note that the grade for the kitchen area has been built up (as the kitchen floor is above the floor in the shop and offices areas). The surrounding ground cover is gravel with patches of asphalt. Fuel-powered vehicles pull into the shop area via the bay door on occasion. No washers or dryers are present in this building.

No PID detections were observed in the ambient air throughout the building. The only PID detection observed in a drain feature was from the drain line just west of the offices at 197.0 ppm.

5.6.16 Building 774

Building 774 was constructed in the late 1950s to mid-1960s and is located in the northeastern quadrant of the Midland facility. The building contains a control room, a kitchen/lunch room, lab space, bathrooms, and office space within a large shop space. The structure is predominantly two stories, with the exception of the eastern portion that contains the control room area, which is only one-story. Building 774 is a slab-on-grade construction with no basement and no elevator and has a footprint of 12,123 ft². The large shop area has three bay doors. The large eastern bay door is opened the most, while the other two bay doors are seldom open.

The shop area is heated via steam radiation and the control room area is heated via hot air circulation. There is one central AC unit for the control room area and two individual AC units for enclosed office spaces found in the shop area. All intakes are located indoors and the building has two lab hoods for ventilation in the lab areas. The surrounding ground cover outside the building is asphalt. Fuel-powered vehicles and fork trucks are able to pull into the shop area. Occupants of Building 774 use the laundry facilities found in Building 719.

At the time of the survey, no PID detections were observed in the ambient air throughout the building or from drains found in the bathrooms and shop area.

5.6.17 Building 1269

Building 1269 was built in the late 1980s to early 1990s and is located in the northeastern quadrant of the Midland facility. The building is a one-story slab-on-grade construction with no basement or elevator. Building 1269 is occupied by an insulator contractor and consists of a large shop space with a bay door, an office, a break room, and two bathroom areas (one of which has a washer/dryer setup). The structure has a footprint of approximately 2,996 ft².

The building is heated via hot air radiation and is cooled via an individual AC unit located near the southeastern corner of the building for the office. There are also mechanical and ventilation fans in the building. The surrounding ground surface outside the building is covered with grass to the north, and a

mixture of concrete, asphalt, and gravel to the east, south, and west. The bay door on the shop is open more often during warmer months or when supplies are being moved in and out of the shop. The bay door is large enough to allow a fuel-operated vehicle to pull into the building, and a propane-fueled fork truck is used in the warehouse.

No PID detections were observed in the ambient air or any drain features at the time of the survey.

5.6.18 Building 27/313/803

The Building 27/313/803 complex is located in the northeastern quadrant of the Midland facility. These buildings were combined as they share walls with openings between them that are permanently open. The entire complex has been built in phases per aerial photography. The eastern portion of 313 was built prior to 1938, and the western portion was built in the 1940s. Building 803 was built in the 1970s and Building 27 in its present layout was constructed in the 1990s-2000s.

The 27/313/803 complex contains two small office spaces, warehouse spaces, and process areas and has a footprint of approximately 36,007 ft². The sum area of the footprint attributed to process areas is approximately 6,890 ft². The two small office spaces are located in the northwestern corner of the 313 portion of the structure (this office area is referred to as the "shipping office") and the second is located in south-central area of the 803 portion of the structure. The small office in 803 is used an hour or two a day to monitor the blending processes in 803. The entire structure ranges anywhere from one to five stories and is a slab-on-grade construction with no basement and no elevator.

The complex is heated via steam radiation, and the shipping office and blending area each have their own central AC unit. Vents are present on the northern and western side of 27 and on the western side of 803. Intakes are located on the roof for each central air unit. The complex has nine bay doors, five of which are on 27 and four are on 313. They are typically closed with the exception of a few times during the summer months. The surrounding outdoor ground cover is concrete and asphalt to the north and east and gravel to the west and south. Propane-fueled fork trucks are used in the packaging/warehouse area.

A PID detection of 0.1-0.4 ppm was observed in the ambient air in the 803 blending area at the time of the survey.

5.6.19 Building 458/963

The oldest part of Building 458/963 was built in the 1960s and is located in the northeastern quadrant of the Midland facility. Buildings 458 and 963 are connected via a corridor on their western side and eastern sides, respectively, that cannot be closed off; therefore, these buildings will be combined for further assessment. The combined footprint of this complex is approximately 95,174 ft². The combined portion of the footprint attributed to process areas is 25,770 ft². Of the non-process footprint, roughly 46,347 ft² consists of open areas with high ceiling heights (> 16 ft). The enclosed office areas cover approximately 23,057 ft².

The Building 458 portion is used predominantly as a warehouse for the Ion Exchange Anion operation; however, there are office areas located in its northeastern corner and western warehouse area. A vacant lab that is in disrepair is located just to the south of the northeastern office area. There is also a shop area with offices located on the eastern side of the western warehouse area. There is some process areas associated with the packaging areas throughout the structure.

The Building 458 portion is a slab-on-grade construction with no basement or elevators. However, some areas of the grade have been built up or dug into, such as the warehouse for the purpose of loading/unloading trucks or for packaging/process purposes, respectively. The structure is roughly one to three stories tall, with warehouse areas having ceiling heights that are approximately two to three stories high. The 458 portion of the complex is heated via steam radiation through one internal pass. Central AC is used to cool the northeastern office area of 458 via cooling towers located on the roof. The shop

offices and shipping office found in the western warehouse are cooled via individual AC units. There are also some mechanical fans throughout the building. An outdoor intake is located on the north side of the building. The building has 10 bay doors, seven of which are truck bays, and the other three are slider doors. These bay/slider doors are typically shut during the winter and are open for deliveries and more frequently during the summer. The ground cover outside of the building consists of mainly concrete and asphalt, but there is some gravel on the north side near the railroad tracks. Propane-fueled fork trucks are used throughout 458. Occupants use washers and dryers found on the second-story of the northeastern office area.

Part of Building 963 (occupied by the Cation/Ion Exchange operation) was built in the 1970s, but the southern portion containing predominantly office space and locker rooms was added in 1991-1992. The Building 963 portion of the 458/963 complex contains offices, a control room, safe work permit writer area, locker rooms, laundry facilities, a kitchen/break room, labs, and a large process area on the north side. This portion of the complex is mostly a three-story structure of slab-on-grade construction that is heated via hot air circulation and cooled via central AC. The 963 portion has two handlers with scrubbers, one of which is located west of the control room and labs on the first floor, and the second is located on the east side of the third floor. Outside air intakes are associated with both of these air handlers. The control room area has an epoxy coating on its floor. The building does not have a basement and also does not have any bay doors/overhead doors. The building does have an elevator, which is located just inside the southern entrance. The ground cover outside of the building is predominantly concrete and asphalt.

For the 458 portion of the complex, PID detections were observed in the ambient air in the western warehouse (0.2 ppm), the shop area (0.1 ppm), the corridor connecting the western warehouse area to the eastern half of the building (1-1.6 ppm), and in the northeastern office area (0.1 ppm). However, no PID hits were observed from any drains encountered while walking through the 458 portion of the complex during the survey. A PID detection of 0.1 ppm was observed at the time of the survey in the laundry room and the control room area of the 963 portion of the complex.

5.6.20 Building 542/561

Building 542/561 was built sometime during the 1940s-1960s and is located in the northeastern quadrant of the Midland facility. These warehouses are used to store finished and/or intermediate product for the Ion Exchange and Copolymer operations. Electric fork trucks are used throughout the structure, and occasionally a gas-powered sweeper is used. The warehouses, 542 and 561, have been combined for this assessment as they are connected to each other via two corridors located in their northeastern and southwestern quadrants, respectively. The combined footprint for this building is 162,427 ft². Office areas located in 561 and a small office-like area in 542 have a combined footprint of 7,472 ft², whereas the large, open warehouse areas have a combined footprint of 154,955 ft².

The structure is a slab-on-grade construction with no basement and no elevators. The building is anywhere from one to two stories (the office area in the northeast corner of 561 has two stories). The ceiling height of the open warehouse areas are roughly two to three stories tall. The ground cover outside around the structure is predominantly asphalt with some gravel located to the north and west.

Building 542/561 is heated via steam radiation. There are intakes located on the roof on the northern side of the building for the unoccupied office areas. The occupied office area located on the east central side of 561 has an individual AC unit that is located inside the warehouse. The entire structure has over 20 bay doors, with the bay doors attached to the truck bays on the eastern side of 561 being opened the most frequent. Occupants of this building would use the laundry facilities found in Building 719.

PID detections were observed in the ambient air at:

- The northeastern office/shop area of 561 (0.1-0.2 ppm);

- The northern warehouse area of 561 (0.1 ppm);
- The area near the eastern bathrooms of 561 (0.1-1.6 ppm);
- The southeast corner of 561 (0.2-0.4 ppm); and
- The northwest quadrant of 542 (0.1-0.4 ppm).

5.6.21 Building 719/1360

Building 719/1360 is located in the northeastern quadrant of the Midland facility. Buildings 719 and 1360 are connected to each other via an opening in a shared warehouse space located in their northwest and southeast corners, respectively. The 719 portion was built sometime in the late 1950s to mid-1960s. The 1360 portion was built sometime in the 1980s to early 1990s. The combined footprint of these structures is approximately 74,964 ft². The process areas for both of these buildings have a combined footprint of 10,846 ft². The large warehouse and process spaces have a combined footprint of 67,514 ft², and the enclosed office areas have a footprint of 7,450 ft².

The 719 portion (59,763 ft²) of the complex contains office space near its northwestern corner, and a process area on its west central side just south of the office area. The process area (4,818 ft²) is used to complete the finishing and screening of product. To the south of the process area is a narrow corridor that contains an office, locker room, and control room. An additional control room exists in the north central portion of the warehouse. The majority of the 719 structure is warehouse space used to store final product. The office area and warehouse areas are both one-story, but the ceiling height in the warehouse is roughly two stories tall. The process area is approximately four stories.

The 1360 portion (8,171 ft²) of the complex is predominantly process areas that range from being open air, partially walled, to fully enclosed. The process areas range anywhere from two-to three stories tall up to seven stories and have a footprint of 6,027 ft². There is some warehouse space located on its eastern and southern sides of the structure, which is one-story tall with ceiling heights roughly equivalent to two stories. A small lab and storage area are located just to the south of the partially enclosed portion of the process area. The lab/storage area is only one-story tall.

Both parts of the structure are a slab-on-grade construction with no basement. Note that the grade has been built up in some portions of 719 to facilitate loading/unloading trucks. Any elevator or lift-like devices are located in process areas. Both structures are heated via steam radiation. The office areas of 719 and the lab/storage area of 1360 are cooled via central AC. The control rooms in 719 have individual AC units. The air intake for the 719 office area is inside the warehouse and the air intake for the 1360 lab/storage area is on its roof. There are multiple louvered vents on the southwest and northeast sides of 1360 as well as on the southwest corner and eastern side of 719. The structure has a combined total of 12 bay doors. The bay doors are typically only open for deliveries, pickups, or moving equipment in and out of the buildings; however, sometimes these doors are left open during warmer months while the buildings are occupied. The surrounding ground cover outside these buildings consists of gravel to the northwest of 1360 and to the east and northeast of 719 with the remainder of the ground surface around these buildings being covered by asphalt and concrete. Propane-fueled fork trucks move throughout this structure, and occupants would use the washers and dryers available in the locker rooms found in 719.

No PID detections were observed in the ambient air or from the drains observed in the lab/storage area in 1360. A minor PID detection of 0.1 ppm was observed in the ambient air in the offices of 719. A drain in the western office bathroom area of 719 had a detection of 0.3 ppm, and the drain in the women's locker room had a reading of > 2,000 ppm. However, the women's locker room was very humid and the drain had water in it. False positive readings on a PID may occur in the presence of excess water vapor. High humidity can cause lamp fogging and decreased sensitivity. This can be significant when moisture levels are high in the general area to be measured.

5.7 Zone 3 Phase 3 Buildings

As discussed in Section 5.5, the 2018 Revised VI Work Plan included the sampling plans for priority buildings in Zone 3 that were initially referred to as Zone 3 Phase 1. As stated in the September 26, 2018 email to EGLE, only nine Zone 3 buildings were sampled in the fall of 2018 which were identified as Zone 3 Phase 1. The additional Zone 3 buildings presented in the workplan were reprioritized so that Dow could focus on additional investigations for priority buildings in Zones 1 and 2. The remainder of the buildings initially identified as Zone 3 Phase 1 became Zone 3 Phase 2 and were sampled in Fall 2019. All remaining priority buildings identified in Zone 3 will be Zone 3 Phase 3 and are currently scheduled for sampling in Fall 2020.

The Zone 3 geographical area contains 214 buildings and structures that were visited and categorized. Following the VI Categorization Flowchart (Figure 5-2), there are 16 buildings in Zone 3 Phase 3 categorized as priority buildings (Category 1 and 2). These buildings were identified for further evaluation, including the completion of a building survey and future sampling activities.

Surveys for the Zone 3 priority buildings were completed from March 12, 2018 through May 4, 2018. As part of the surveys, a brief kick-off meeting was conducted with primary building contacts to complete the survey questionnaire and any obtained pertinent information, such as floor plans. After this meeting, the building survey was completed including gathering a chemical inventory (if one was not provided) and taking PID readings of the ambient air and drain features were recorded.

The surveys for the Zone 3 Phase 3 priority buildings, which include the survey, floorplan, chemical inventory and PID readings, are found in Appendix D. Sampling plans will be submitted prior to sampling Zone 3 Phase 3.

Zone 3 Phase 3 contains 16 buildings, including nine (9) Category 1 buildings and seven (7) Category 2 buildings.

Category 1 buildings:

- Building 25 – Remediation – AECOM/Dow;
- Building 354 – Saran, Converted Products & Dow Auto;
- Building 433A – Styron Polymer/Shipping;
- Building 574 – Computer Systems;
- Building 608 – Buttles Street Gate;
- Building 845 – Control Room for 588 (6-2590);
- Building 1319 – Offices for 845;
- Building 1354 – Electronic Storage Device Materials; and
- Building 1616 – Mech Dev & Operations.

Category 2 buildings:

- Building 695 – Shop & Fabrication Area;
- Building 856 – Res Service Glass Fab Shop;

- Building 872 – MRO;
- Building 1302 – Storage Barn;
- Building 1351 – Electronic Storage Device Materials;
- Building 433W – Shipping; and
- Building 433B – Styrene Polymers.

The following subsections summarize the findings of the surveys completed at these buildings during the early spring of 2018.

Category 1 Buildings

5.7.1 Building 25

Building 25 was built in the 1990s-2000s and is located in the northwestern quadrant of the Midland facility. The building consists of office space, conference rooms, bathrooms, and a kitchen/break room. It is a slab-on-grade construction with no basement or elevator and has a footprint of 7,368 ft². The 20-25 full time occupants typically work for 8 hours a day Monday through Friday. On occasion, staff may work 10 to 12-hour days or on a weekend but it is rare that they would be in the structure for that whole duration. The air is heated via hot air circulation and the air is cooled via central AC. The outside air intake is located on the west side of the building. The structure has no bay doors and the outside ground cover is asphalt. Some occupants have a few clothing items laundered by a contracted laundry service, but normally use this service via another building (Building 833). At the time of the survey, no PID detections were observed in any drain features or the ambient air throughout the building.

5.7.2 Building 354

Most of Building 354 was constructed in the 1940s but part of the west side of the building was added/modified in the 1980s-1990s. Building 354 is located in the northeastern quadrant of the Midland facility and has a footprint of 21,919 ft². The building consists of office space in the eastern 25% of the structure, with the remainder of the building being used for large R&D/T,S&D labs for SK Saran and Dow Polyurethane. The structure is a slab-on-grade construction with no basement, but there is an elevator in the office area. The floors are a painted concrete in the SK Saran portion of the labs and are an epoxy-coated concrete in the Dow Polyurethane portion of the lab. Building 354 is two stories, but the lab area ceiling are two stories high. Four people hold offices in this building and at most 12 people are in the building on any given weekday. Occupants typically work 8 to 10-hour days Monday through Friday with the first occupants showing up at 7AM and the last occupant leaving at 5PM.

The building is heated via steam radiation that is heated via natural gas, and the building is cooled via central AC via a combination of multiple cooling towers and medium to large AC units. There are multiple outside intakes, which are found on the south and north sides of the structure. The building has three bay doors, two are located on the west side and one is located on the south side. The bay doors on the west side are frequently opened more during the summer, and the one on the south side has a poor seal. The outdoor ground cover around the building consists of grass on the north side and asphalt to the south, west, and east. A propane-fueled fork truck is used to move containers/equipment in and out of the lab areas. Occupants occasionally use a contracted laundry service.

During the survey, a PID detection of 0.3 ppm was observed in the ambient air in the SK Saran portion of the lab space, and PID detections of 70.6 ppm and 4.0 ppm were observed from the drains found in the southeastern and northwestern corners of the SK Saran lab. No PID detections were observed in the

ambient air throughout the office space or in the Dow Polyurethane lab areas nor were detections observed in any other drain features throughout the building.

5.7.3 Building 433A

Building 433A was built in 1943 and is located in the northeastern quadrant of the Midland facility. Building 433A is sometimes referred to as two different structures, 433 and 433A. The 433A numbering often refers to the eastern lab wing of the structure (and is painted on the outside of the building); however, the entire structure is most commonly referred to as Building 433. The southern warehouse shares a firewall with the structures referred to as Buildings 433W and 433B, but these structures are presently owned by Trinseo and are considered Category 2 structures. Building 433A has an approximate footprint of 122,396 ft². The large warehouse area has a footprint of 50,693 ft², and the enclosed office and lab areas have a footprint of 71,702 ft².

Building 433A contains many offices, T,S&D labs (located in the eastern wing and northwestern/west side of the building), and a large warehouse space on the south side. Approximately 150-200 people occupy this building. The occupants work anywhere from 8 to 12-hour days Monday through Friday starting at 6AM and ending at 6PM. Occasionally, some people come in on the weekend. The structure is a slab-on-grade construction (with the grade having been built up above the natural ground surface) and has no basement. Two elevators are located in the occupied areas as the building has four floors in some portions of the structure. There is also a freight elevator located on the southern side of the warehouse. The flooring in the eastern wing and in the labs consists of either painted concrete or concrete covered with an epoxy coating.

The building is heated via steam radiation and has several central AC cooling towers/units, most of which are found on the roof. Multiple intakes are found on the roof, and a large intake is located on the west side of the building. The building has six bay doors that are typically only opened for the purposes of deliveries or for moving equipment/materials in or out. The surrounding outdoor ground surface is asphalt. Propane-fueled fork trucks are often used in the large labs or warehouse to move around equipment and materials. There are a few washers and dryers dispersed throughout the building, and a few occupants use a contracted laundry service on occasion.

No PID detections were observed at the time of the survey in the ambient air of from any drain features found throughout the building.

5.7.4 Building 574

Building 574 was built between 1952 and 1958 and is located in the northeastern quadrant of the Midland facility. Building 574 is attached to another structure located to the east, Building 633, via a second-story pedestrian bridge. However, the pedestrian bridge is closed and Building 633 is presently unoccupied with no immediate future plans for occupation. The northern 75% of the structure is office space and the southern 25% consists of a shop, break room, and large mechanical room. Building 574 is a two-story slab-on-grade construction with no basement and has an approximate footprint of 26,538 ft². There is an elevator located on the eastern side of the building. Approximately 125 people occupy this building and work 8 to 10-hour shifts Monday through Friday.

The building is heated via hot air circulation and is cooled via central AC. The AC is provided by an air chiller in the spring and fall, and a cooling tower is used for the summer. A large air intake is located on the southeast side of the building. The building pulls 100% of its air from the outside and has positive air pressure. One bay door exists on the southwestern corner. This door is open on a daily basis for hours at a time and is occasionally open to exhaust hot air out of the lab if the AC is not functioning properly. The bay door is large enough that a vehicle could pull into the shop area. The outside ground cover around the building consists of asphalt to the south, west, and east; grass and some bushy vegetation is present on northern side between the building and D street.

No PID detections were observed in the ambient air nor from any drain features in the building at the time of the survey.

5.7.5 Building 608

Building 608 was built between 1993 and 2015 per aerial photography and is located in the northwestern quadrant of the Midland facility. It is a small structure (961.98 ft²) used to house a guard at the Buttles Street Gate. The guard works a 12-hour shift from 6AM to 6PM Monday through Friday. The building consists of a small area for the guard to sit, a break area, a mechanical room, a janitor's closet, and a bathroom. The building is a slab-on-grade construction with no basement, no elevator, and no bay doors. The building is heated either via hot air circulation or an electric baseboard (depending on which one is functioning properly at any point in time). The building is cooled via a central AC unit located on the southwestern side of the building. The outside ground cover around the building is predominantly a combination of sidewalk, gravel beds, and asphalt. Some patches of grass exist in the beds located between the sidewalk and asphalt. No PID detections were observed in the ambient air nor in the drains observed in the building at the time of the survey.

5.7.6 Building 845

Building 845 was built in the 1970s and is located in the northeastern quadrant of the Midland facility. On average, Building 845 is a three-story structure. The building consists of a long north-south corridor that has office space, bathrooms, locker rooms, and break areas and is predominantly two stories. Off of this corridor are seven "Mods" numbered 1 through 6 with an additional Mod numbered as "4.5". These Mods are anywhere between two- to four-stories tall. The Mods are used for various R&D/lab purposes; however, Mods 4, 4.5, 5, and 6 are actively being stripped of their contents in 2018 to possibly be repurposed in the future. Mod 1 is a laboratory and Mod 3 is presently being used as a storage area. Mod 2 is actively in use and has an associated lab located just to the north of it. Building 845 is a slab-on-grade construction with no basement and has a footprint of 25,326 ft². The building has eight bay doors that are open more frequently during warmer weather and are open to move things in and out of the structure. There is also a freight elevator in the building.

The air in the building is cooled through a combination of large central AC units and individual AC units. The air is heated via steam radiation and there are multiple outdoor intakes located on the roof and around Mods 1 through 3. The floor in Mod 1 has an epoxy coating, but the other Mods mainly have bare concrete floors. The ground cover outside the building is predominantly asphalt with some gravel located to the northeast. Approximately 10 to 20 people occupy this building and work anywhere from 8 to 12 hours a day Monday through Friday. The occupants use washers and dryers in the building and propane-fueled fork trucks are often used in the Mods. The bay doors on the Mods are large enough to allow a vehicle to pull inside.

No PID detections were observed in the ambient air throughout the building or from any drains identified during the survey.

5.7.7 Building 1319

Building 1319 was built sometime between 1982 and 1993 (per aerial photography) and is located in the northeastern quadrant of the Midland facility. The building contains office space used to support Building 845, which is located to the east of Building 1319. Approximately 10 to 20 occupants sit in this building 8 to 12 hours a day Monday through Friday. This one-story building is a slab-on-grade construction with no basement or elevator and has a footprint of 6,120 ft². The outdoor intake is located on the north side of the building near the northeastern corner (outside of the mechanical/HVAC room) and is associated with one chiller and air handler. The building is heated via steam radiation, and no bay doors are present on this structure. The ground cover outside of the building is asphalt. No PID detections were observed in the ambient air or from any drain features identified during the survey.

5.7.8 Building 1354

Building 1354 was constructed in the last 5-10 years and is located in the northeastern quadrant of the Midland facility. The structure is a slab-on-grade construction with no basement or elevators and has a footprint of 8,636 ft². The building consists of offices, a control room, kitchen/break room, conference rooms, locker rooms, and a lab. The building is used as a support building for Silicone, Sealants, and Adhesives operations. There are roughly 50 to 60 people who pass through this building on a daily basis, but roughly 20% of those people occupy the building in 12-hour shifts that span from Monday to Friday. The shifts will change once the operations for Silicone, Sealants, and Adhesives is fully operational.

The building has central heating and cooling. Three AC units are located on the west side of the building along with three outdoor intakes. The building has no bay doors. The ground cover outside of the building is covered with either concrete or asphalt. Occupants in the building use a contracted laundry service for some clothing worn at work.

No PID detections were observed in the ambient air or from any drains observed at the time of the survey.

5.7.9 Building 1616

Building 1616, which houses the Materials Engineering Center, was built in the 1990s and is located in the northeastern quadrant of the Midland facility. About 35 people occupy this building for 8 to 10 hours a day anytime from 6:30AM to 5PM Monday through Friday. It is a slab-on-grade construction with no basement or elevators and has a footprint of 40,077 ft². The northern third of the building consists of offices, kitchen/break rooms, and conference rooms. The southern two thirds of the building are predominantly occupied by labs and a large machine shop area with a few offices, a large kitchen, and a locker room. The building is mostly one-story but has a partial second-story located in the central part of the building. The building is heated via steam radiation and is cooled via central AC by a large cooling tower located on the west central portion of the roof. The outside intake is also located on the west central portion of the roof. The ground cover immediately outside the building consists mainly of grass with some asphalt areas to the north and west.

Building 1616 has one large bay door located near the southeastern corner, which opens up into the large shop area. The bay door is only opened for the purpose of deliveries. However, the door is large enough for fuel-powered vehicles to come into the building. A propane-fueled fork truck is sometimes used in the large shop area. The ceiling height in the large shop area is roughly two stories tall and has an epoxy coating on its concrete floor.

No PID detections were observed in the ambient air throughout the building or from any drains observed at the time of the survey.

Category 2 Buildings

5.7.10 Building 695

Building 695 was constructed sometime between 1965 to 1982 (per aerial photography) and is located in the northeastern quadrant of the Midland facility immediately to the southeast of Building 845. Only one person occupies this building and they work anywhere from 8 to 12 hours a day Monday through Friday; however, they do not spend the entire shift in this building. It is a single-story slab-on-grade construction with no basement or elevator and has a footprint of 1,695 ft². The building is predominantly three large shop spaces, but on the eastern side of the building there is a bathroom, kitchen/break room, and office. There is one bay door located on the west side of the building that is rarely open. There is central AC in the office/kitchen area. The building is heated either via an electric baseboard (bathroom) or through forced hot air from a furnace located in the shop area. The ground cover outside the building is asphalt. No PID detections were observed in the ambient air or from any drain features during the survey.

5.7.11 Building 856

Building 856 was built in the late 1960s to early 1970s and is located in the northeastern quadrant of the Midland facility. It is occupied by two scientific glassware fabricators who work 10-hour days Monday through Thursday from 7AM to 5PM. The building is predominantly a shop area, with two offices located near the southeast corner. The eastern part of the building consists of a secondary shop area and parts storage. The building is one-story with the exception of the eastern 25%, which has a second-story. The second floor of this building is not used and is rarely entered. The building is a slab-on-grade construction with no basement or elevator and has a footprint of 11,906 ft². The floors are concrete but are painted with a clear coating.

The building is heated via steam radiation and electric baseboards. The intake for the building is located on the east side at ground level near the southeastern corner. The building is cooled via a combination of central and individual AC units. There are also mechanical and bathroom ventilation fans in the building. The ground cover outside of the building is predominantly asphalt, with the exception of some gravel on the west side of the building. Occupants use the washers and dryers located in the southwest corner of the building.

No PID detections were observed in the ambient air throughout the building, and no detections were observed from any drain features in the building.

5.7.12 Building 872

Building 872 (68,616 ft²) was built between 1965 to 1982 (per aerial photography) and is located in the northeastern quadrant of the Midland facility. The building is operated by the Dow Maintenance group. Approximately 20 people occupy this building and work four 10-hour days a week (Monday through Thursday) from 7AM to 5-5:30PM. The structure is a slab-on-grade construction with no basement, but the majority of the building has been built on grade and has been built up approximately 3 ft above the natural ground surface due to the truck bays. Building 872 has no basement or elevators. The building is predominantly warehouse space with offices areas and locker rooms located on the eastern side of the building. The large, high-ceiling warehouse area has a footprint of roughly 48,813 ft². There are also two enclosed office areas/break room areas located in the central portion of the warehouse. All enclosed offices, locker rooms, and break room areas have a footprint of 19,803 ft².

Building 872 is approximately two to three stories tall, with the office and locker room areas having one-story ceiling heights and the warehouse area having ceiling heights comparable to two to three stories. The kitchen/breakroom area in the warehouse has two stories, whereas the other warehouse office location is only one-story. The eastern outer corridor of the warehouse has a second level deck. Along the eastern and western sides of the eastern outer warehouse corridor there are large 3 ft-wide grates that open up to the natural ground surface.

The building is heated via steam radiation and is blown throughout the building via mechanical fans. There are intakes located on the east side of the building off of the upper deck. There are two individual AC units off of the offices/break room areas in the warehouse. The eastern office area is cooled by central AC unit connected to an air handler located to the southeast of the men's locker room.

Building 872 has 28 bay doors. Several of the bay doors on the southern side of the warehouse are inaccessible due to shelving units. The bay doors are typically closed unless equipment/materials are being moved in and out of the building. The ground cover outside the building is predominantly asphalt with some gravel to the west near the railroad tracks. Propane-operated fork trucks are used in this warehouse.

No PID detections were observed in the ambient air or from any drain features in the building at the time of the survey.

5.7.13 Building 1302

Building 1302 was constructed in the 1980s-1990s and is located in the northwestern quadrant of the Midland facility. The structure is used by Dow Remediation and their contractor, AECOM, as a warehouse/work space and for a document library. There is no full-time occupancy; however, occupants from Building 25 frequently access the building and may work in it for hours at a time. The 3,004 ft² one-story building is a slab-on-grade construction with no basement or elevator. The ceiling height in the warehouse portion of the structure is close to two stories in height.

The building is not heated, but there is an individual AC unit for the library located on the east side of the building. The building has two bay doors, one near the northwestern corner on the west side and one on the south side. These doors are typically closed unless equipment/materials are being moved in or out of the structure, or if someone is working in the building during warmer months. The ground cover outside of the building is grass on the east side, asphalt to the west, and gravel to the north and south. Fuel-powered vehicles are sometimes driven into the warehouse and parked overnight or for several days.

No PID detections were observed in the ambient air while completing this survey.

5.7.14 Building 1351

Building 1351 (with a footprint of 15,933 ft²) was built in the 1980s-1990s and is located in the northeastern quadrant of the Midland facility immediately east of Building 1354. Building 1351 is part of the Silicones, Sealants, and Adhesives operation, but it is temporarily being used as a space for contractors to take breaks and stage equipment and materials as Building 1353 (to the east) is constructed. When construction of Building 1353 is complete, the use of Building 1351 will change to be predominantly a clean-room process area on the first floor with some office space and occupants will work 12-hour work shifts. Building 1351 has a corridor located on its northern side that has a locked bay/overhead door that leads into Building 542/561. Building 1351 is a slab-on-grade construction with no basement and has anywhere from one to three stories in different parts of the building.

There is an elevator located to the south of the future clean room process area and to the west of the present contractor breakroom area.

The air in the building is heated via either steam radiation or hot air circulation. Three AC/air handler units with associated intakes were identified during the survey. One unit is located on a first floor roof on the northwest corner near the corridor connecting the rest of 1351 to 542. The other two units are located on the southern second-story roof. There is one large bay door on the east side of the building that opens into a large shop area that is presently being used by contractors working on Building 1353. This bay door allows vehicles and some large machinery to temporarily pull into the shop area for storage.

The northwestern portion of the shop area has a dirt floor, while the rest of the shop area has a combination of either asphalt or concrete. There also appears to be a sump-like feature located in the northwestern corner of the shop area. Much of the flooring in 1351 is concrete flooring covered with a glossy paint. The ground cover outside around the building is asphalt.

No PID detections were observed in the ambient air or from any drain features at the time of the survey.

5.7.15 Building 433W

Building 433W was built in the 1940s-1950s and is located in the northeastern quadrant of the Midland facility. Buildings 433W (433 Warehouse) is owned by Trinseo and is connected to the southern warehouse of Building 433A on its northern side via a firewall with large bay door-sized openings (which is owned by Dow). The building is predominantly a large warehouse space for the storage of final product but has enclosed areas that consist of an unoccupied lab, locker rooms (which have washers and dryers), a kitchen/break room, offices, storage, and a control room. There are also rail lines that run through the

central part of the structure that enter from rail doors located along the southern wall. Propane-fueled and electric fork trucks are used throughout the structure, and railcars and track mobiles are frequently moved in and out of the structure. Approximately 10 people are working in the building at any given time. The workers are present Monday through Friday for 8-hour work shifts that start at 7AM and last until 3-3:30PM.

The footprint of 433W is approximately 117,511 ft². The large warehouse space of this structure has a footprint of approximately 111,666 ft², whereas the enclosed office, lab, and break room areas have a combined footprint of 5,845 ft². The building is a slab-on-grade construction (although the grade is built up above the natural ground surface) with no basement. The entire structure is approximately four stories tall. A freight elevator is located on the northern side of the shared firewall between 433W and 433A. The ground cover immediately outside of the building is predominantly a combination of asphalt and concrete, with gravel patches located in some areas.

Building 433W is heated via steam radiation, and has a combination of mechanical fans, central, and individual AC units to cool the building. The central AC units have outdoor intakes located on the southern and eastern sides of the structure. Building 433W has 12 bay doors. The bay doors on the eastern side of the warehouse are only open for when a truck comes in for a delivery or pickup. The rail doors on the southern side of the building are open more frequently.

At the time of the survey, a PID detection was observed in the ambient air in the control room and the old trucker office (which is now storage) at 0.1 ppm and 0.3 ppm, respectively. No PID detections were observed from the drains located in the locker room.

5.7.16 Building 433B

Building 433B was built in the 1940s-1950s and is located in the northeastern quadrant of the Midland facility. Building 433B is owned by Trinseo and is connected to the southern warehouse of Building 433A (which is owned by Dow). The entire structure is approximately four stories tall and consists of an enclosed area that contains process areas, office space, warehouse space, and shop space. A large portion of the process area is partially enclosed or open air and is located to the east and south of the main structure. One operational personnel is always present on an 8-hour shift. Operational staff are present 24 hours a day, 365 days a year. Maintenance staff works an 8 to 9.5-hour shift from 7AM to 4:30PM Monday through Friday. The ground cover outside of the building is predominantly concrete or asphalt with some minor gravel patches.

The footprint of 433B is 39,687 ft². The non-process areas associated with this structure have a footprint of approximately 17,217 ft². The building is a slab-on-grade construction (although the grade is built up above the natural ground surface) with no basement. Building 433B has two elevators on the east side of the building, one of which is not functioning and the other is used to facilitate the process area of 433B. The enclosed portion of the building has two bay doors, which are typically closed during the winter and are opened during the summer for the purpose of cooling the building. The entire combined structure is heated via steam radiation. There are mechanical fans throughout the building, and there is an individual AC unit for the break room area. Occupants of this building use laundry facilities that are located in 433W and 1350. The occupants in shop areas/general areas use propane-fueled forklifts and electric golf carts to move around the building.

No PID detections were observed from any drains in the building at the time of the survey. PID detections were observed in the ambient air in the expendable storage area (0.1 ppm) and in the kitchen/breakroom (0.4 ppm).

6.0 DIRECT CONTACT TO SOIL PATHWAY

Soil DC is an exposure pathway that includes exposure via long-term dermal contact with and ingestion of soils throughout the soil column, regardless of depth. The focus of this on-site investigation is to evaluate the potential shallow surface soil DC exposure pathway for site workers and contractors.

The Midland Facility is a 1,900-acre industrial facility. The facility's land use is non-residential and includes nearly 400 acres of industrial ponds. The surface cover at the site currently includes approximately 600 acres of buildings and pavement. Roughly 220 acres of the Midland Plant are vegetated final cover installed from 1980 to 1989 for closed WMUs. Nearly 70 acres of new topsoil and vegetative cover have been placed on areas of the plant as part of Phase I Enhanced Exposure Control activities and other greenbelt enhancements. An additional 100 acres of vegetative stormwater detention areas have been constructed from 2009 to 2011.

Significant work has been completed to date to improve surface cover at the Midland Plant; however, there are still areas that are eligible for assessment in order to determine if surface improvements are warranted. In order to conduct this evaluation for the DC pathway, the site was split up into manageable areas, primarily referred to as Zones (Figure 6-1).

Ongoing efforts to address worker exposure to impacted soil on site at the Midland Plant are implemented under the on-site Worker Exposure Control Plan (Appendix C of Attachment 19 of the License). The objective of the Worker Exposure Control Plan is to describe the implementation of various interim measures at the Midland Plant designed to address potential exposure pathways to on-site workers as part of final corrective action, in compliance with Part 111 of Michigan Public Act 451. The Worker Exposure Control Plan will continue to be updated and utilized.

The Surface Soil Exposure Control Program, a component of the Worker Exposure Control Plan, is designed to specifically address DC exposure to surface soils located at the Midland Plant. The goal of the Surface Soil Exposure Control Program and focus of on-going efforts is the elimination of unacceptable DC exposure to surface soils by 2023 in order to achieve "under control" status with respect to DC with soils on the Midland Plant EI.

The Surface Soil Exposure Control Program currently limits fugitive dust controls by street cleaning, applying dust suppressant to gravel roadways and appropriately managing soil stockpiles during excavations. DC management includes PPE and air monitoring requirements during excavation activities and specifies clean cover shall be placed over areas disturbed by excavation. In addition, the Worker Exposure Control Plan will be modified as appropriate in the future to include monitoring and O&M obligations related to maintenance of any surface cover.

Soils relocated within the Midland Plant and from areas of the Tittabawassee River Floodplain are managed in specific areas within the Midland Plant. A listing of these relevant soil relocation activities for 2019 is provided in Tables 6-1 and 6-2.

6.1 Direct Contact Exposure Characterization

A CSM for DC to the on-site soil at the Midland facility is presented in Figure 6-2. This CSM identifies the potential soil exposure pathways and types of sources for the on-site properties. The initial step for each phase (zone) of this project is to determine the types of surface cover in the area to be evaluated and to identify the gravel or grass-covered areas that have not been assessed or recently covered during Dow's surface cover enhancements. In addition to determining the types of surface cover, an evaluation is performed considering historical use in each of the areas to be assessed, as well as the present use and maintenance required to evaluate the types of potential exposure that could occur (e.g., land use and activities that occur on or near those areas). Figure 6-3 presents the Dow Midland Facility Direct Contact Category Flowchart. The flowchart categorizes and describes the property types present, possible sources, exposure types, use (e.g., frequency of activity), and the path forward for sampling.

Exposure and current use are evaluated for each property type in the area to be assessed. Exposure categories include intermittent event-based exposure with regular use, limited exposure with regular to low frequency use, limited access with low frequency use, and limited access or no access with very low frequency use. The combination of property type, possible sources, exposure, and use led to the development of seven categories for DC sampling and evaluation at the Dow Midland Facility. These seven categories are presented in the Table 6-3 along with the sampling frequency for each category.

No sampling is proposed for areas with restricted access (limited to very infrequent maintenance, including the wastewater treatment tanks and dike areas), and areas where pavement or building footprint and slab areas under process areas impede exposure to soil via DC. The Rail Yard and Electrical Substation will be evaluated as individual, complete areas and are deferred to a later date. Access to each of these areas is limited by either train activity or fencing. Evaluating these areas will involve strict safety considerations.

6.2 Target Analyte Lists and Sampling Density

Four possible general sources of impacts were identified for the Midland Facility. These include aerial dispersion, imported soils, leachate breakout, and other sources (e.g., point source release, historic area operations). These sources of impacts were used to establish the target analyte lists (TALs) for the property types listed in Table 6-3 and Figure 6-3 and are described in more detail below:

- Aerial dispersion includes areas potentially impacted by the historical aerial release.
- Imported soils are soils brought on-site as final cover for excavations or where site soils were relocated. Soils were imported from regional agricultural areas and may not have been tested when acquired.
- Leachate breakout determined from RGIS detections,
- Other sources (e.g. point source release and historic area operations)

The aerial dispersion TAL includes dioxins and furans and arsenic. All areas classified as Categories 1 and 2, are sampled for this TAL. Areas classified as Categories 5 and 6 warrant limited confirmation sampling based on exposure and use; therefore, at least 20% of the area within these categories is sampled for the aerial dispersion TAL.

The TAL for imported soils originally included metals, herbicides, and pesticides. Confirmation sampling for this TAL is proposed for areas covered by imported soils and sampling density was based on category. All areas classified as Category 3 are sampled for this TAL. Due to limited exposure and use, 50% of area classified as Category 4 is sampled and at least 20% of the area within Categories 5 and 6 are sampled for this TAL.

The leachate breakout TAL was determined based on RGIS detections. The TAL includes detected metals, herbicides, pesticides, SVOCs, VOCs, and dioxins and furans. Limited confirmation sampling for this TAL is proposed for those areas covered by landfill cap. Category 6 areas are sampled at a frequency of at least 20%.

The TAL for other sources was determined based on detections from the 2005-2006 Dow On-Site (DOS) sampling effort and the 2010-2015 Worker Exposure Control Program sampling efforts. The other sources TAL includes detected metals, herbicides, pesticides, SVOCs, VOCs, polychlorinated biphenyls (PCBs), and dioxins and furans. All Category 1 areas are sampled for this TAL. Due to limited exposure and use, Category 6 areas are sampled for this TAL at a frequency of at least 20%, and Category 7 areas are generally not sampled; however, specific areas found on vegetated caps closed with EGLE or EPA Oversight and Limited Access have been sampled at the request of EGLE as detailed in Section 6.5.

Table 6-4 summarizes the possible sources of impacts, the determination and TALs for each source, and the applicable exposure category for each TAL.

Based on review of the collective data generated over the first four years of work, some additional sampling, and modification to the TALs and frequency of sample collection are proposed for 2020.

6.3 Sampling Methodology

Due to the anthropogenic deposition of the constituents of concern (COCs) within the sampling areas, a heterogeneous distribution throughout the DC sampling areas is likely. Studies have shown that sampling heterogeneous populations, with individual particles that are likely to have different concentrations of COCs through conventional sampling methods (e.g., discrete or standard composite sampling) inadequately represent the average COC concentration of that population (EPA 2012; Engineer Research and Development Center [ERDC]/Cold Regions Research and Engineering Laboratory [CRREL] 2009; Jenkins et al. 2005). Therefore, an incremental sampling methodology (ISM) is employed throughout the DC sampling areas to provide a more unbiased and reproducible estimate of the mean concentrations of analytes in heterogeneous sample populations.

6.3.1 Incremental Sampling Methodology

ISM is a structured sampling and analytical methodology developed to address the problems associated with collecting representative samples from volumes of particulate material with high compositional and distributional heterogeneity by identifying and minimizing types of sampling and analytical errors. Essentially, ISM is a more robust and ordered type of composite sampling that combines uniform, spatially representative grab samples or “increments” to produce a sample result for an area and depth of soil, or, that is representative of the average concentration of COC of that population sampled. ISM is also more appropriate than conventional discrete sampling for comparison with risk-based screening values and for evaluating concentrations relative to background concentrations.

ISM describes both the field sample collection and laboratory processing methods necessary to obtain samples that contain the COC in the same proportions as the sampled population. Some of the primary differences between ISM and conventional composite or grab sampling are as follows:

- The need to define the spatial boundaries of the DUs;
- A sample mass much larger than required by most analytical methods;
- The number of increments that will be collected in each sample;
- The spacing and distribution of the increments to be collected; and
- The laboratory preparation procedures (ERDC, 2013).

6.3.2 Decision Unit Determination

The evaluation of a zone/sub-zone begins by overlaying a satellite aerial of the area to be evaluated with a 2-acre grid, which represents a non-residential DU. Each of the grids are evaluated for property type and current/historical use. Using this aerial/grid map together with the flowchart presented on Figure 6-2, a rationale is developed for whether sampling is proposed for each grid. If sampling is not proposed, justification for no sampling is documented. For example, areas that are covered by pavement, buildings, or process areas are not proposed for DC sampling. DUs are then delineated throughout the target sampling areas based on site characteristics and historical land use. DUs range from less than 1 acre up to approximately 2 acres. A small percentage of DUs may slightly exceed 2 acres. However, these larger DUs are not further divided due to the site-specific conditions such as the contiguous nature of the land

and/or common past and present land use. In Zones 1-3, for each DU, 10-30 increments were collected, dependent on the acreage of the DU:

- DUs less than 0.5-acre contained 10 increment sampling locations;
- DUs greater than 0.5-acre and less than 1 acre contained 20 increment sampling locations; and/or
- DUs greater than 1 acre contained 30 increment sampling locations.

However, based on the replicate analysis completed on several Zone 1 and Zone 2 DUs, the increment count per DU was increased to 20-50 increments based on the acreage of the DU. This analysis and outcome is discussed in more detail in Section 6.8; however, the changes to the Zone 4 increment amount are as follows:

- DUs less than 0.5-acre increased to 20 increment sampling locations;
- DUs greater than 0.5-acre and less than 1 acre increased to 30 increment sampling locations; and/or
- DUs greater than 1 acre increased to 50 increment sampling locations.

Increment locations are generated using a systematic random sampling approach. The increments were laid out by selecting a random starting point and generating evenly spaced increments based on that starting point using a geographic information system (GIS) program for each DU.

6.3.3 Sample Collection

Maps and global positioning system (GPS) units containing the increment locations within each DU are provided to each sampling team for sample collection. Field teams either first mark all increment locations with a flag prior to collection or work as a team to navigate up and down the rows of sample locations collecting the increments and tracking collection via the GPS device (Figure 6-4).

Ideally, each increment serves as an equivalent portion of the overall sample, which represents the DU as a whole. The ability to take uniform increments at a consistent depth, each representative of a portion of the sample and contributing equally to a representative sample of the entire DU, is greatly dependent on the sampling tool and proper sampling methods.

Generally, increments in most DUs, for all analyses except VOCs, are collected using stainless steel push samplers or Enterprise Venture Corporation (EVS) Incremental Sampling tools in order to ensure that each increment was collected at the same depth and volume. Each increment is collected using a 1-inch diameter coring device to a depth of 6 inches bgs. Once an increment is collected in the device, it is extruded into a bucket lined with a 3 millimeter (mm)-thick 24-inch x 30-inch zip-close plastic bag to create a resulting composite sample with a target mass of between 1 to 3 kilograms (kg).

In areas where the stainless steel push samplers/EVS Incremental Sampling tools cannot advance to the desired depth, such as in heavily compacted gravel areas, an AMS gas-powered core sampler is used. This sampling device consists of a portable gas-powered hammer and hollow stainless steel drive rods capable of driving a 1.5-inch diameter polyvinyl chloride (PVC) liner equipped with a PVC soil catcher to collect a sample. Each increment is collected by driving the rods to a depth of 6 inches bgs. Once an increment is collected (or multiple increments as the PVC liner is capable of collecting up to four increments prior to its contents needing to be extruded), it is extruded into a bucket to result in a composite sample in the same manner as the stainless steel push samplers/EVS incremental sampling tools

For DUs with non-volatile COCs being sent to different laboratories for analyses field replicates are collected for each laboratory so that the entire sample mass is sent to each laboratory for analysis and errors due to splitting samples would be eliminated. Two increment cores are collected approximately 6-12 inches apart and each core went into a different bucket. A 12-inch x 12-inch custom made PVC grid is used to ensure that replicates are collected in the same manner with respect to the primary increment sample location. At each primary increment collection location, the corner of the marked corner of the PVC grid marker is lined up with the increment collection location identified on the GPS. Then an increment is collected from approximately the center of each cell in the grid as necessary to create field replicates. Increment collection is not biased to avoid vegetation; however, vegetation is not included in the analysis of the soil sample. Vegetation included with the collection of the increment remains with the sample until processing either by the field team prior to delivery to the laboratory for the dioxins/furans analyses or by the laboratory for all other analyses.

As VOCs can be quickly lost from an exposed surface additional measures are employed in order to collect a representative sample for DUs that include VOCs on their TAL (Interstate Technology and Regulatory Council [ITRC] 2012; Hewitt, Jenkins, and Grant 1995). For samples collected for VOC analysis, individual increments are collected as 5-gram (g) plugs at the desired core depth and immediately preserved in methanol. A Terra Core® is used to collect a 5-g aliquot from approximately 3 inches bgs from the side of the augered hole and then is extruded into a 1-liter (L) amber jug containing 150 milliliters (mL) of methanol for field preservation.

Each composite sample is assigned a unique sample ID number, which includes the DU designation. Each DU also has a unique ID that corresponds to its category and TAL.

6.3.4 Field Documentation

Each field team is provided with a detailed daily assignment log of sampling units and samples to be collected within each sampling unit. Each field team is responsible for supplying the required information on the form upon sample collection. The sample form includes time of sample collection, date of sample collection, any unusual field conditions or mechanical issues encountered and initial each sample collection line item to verify the entry. At the end of each field day, the Field Team Leader collected all team logs and conducted a quality control check of all samples delivered from the daily activities.

6.3.5 Equipment Decontamination

Solid materials samplers and soil processing equipment, including stainless steel sieves and bowls, are decontaminated according to the following procedures:

- A. Scrub the equipment to remove visible contamination, using appropriate brush(es), approved water, and non-phosphate laboratory detergent.
- B. Rinse with tap water.
- C. Rinse with solvent (acetone).
- D. Rinse with deionized water.
- E. Allow equipment to air dry or wipe dry with paper towels prior to reuse.

All cleaned sampling equipment is stored in a clean environment and covered in aluminum foil or clean plastic sheeting for protection between uses. All decontamination solutions are properly disposed of according to Dow site policies.

6.3.6 Sample Processing and Laboratory Analysis

Collected samples are brought back to a clean designated workspace for further processing or to be packaged directly for shipment to the laboratory. Soils collected for dioxin/furan analyses are sieved through a 2 mm (US Standard #10 mesh) sieve prior to delivery to the Dow Environmental Analytical Chemistry (EAC) lab. During sieving, any vegetation in the composite sample is broken in smaller pieces to release any trapped soil particles and is subsequently extracted from the soil sample; therefore, vegetation is not part of the sieved subsample extracted for analysis. Once the soils for dioxin/furan analysis are sieved, all samples are packed for immediate delivery to the Dow EAC laboratory. Sieved samples are double bagged into Ziploc bags and are labeled in accordance with sample labeling procedures. For soils collected for all other analysis, excluding VOCs, the soils are doubly rebagged in Ziploc bags and labeled in accordance with sample labeling procedures. Soil samples collected for VOC analysis are field-preserved as described in Section 6.3.3.

Samples are then placed in coolers with chain-of-custody forms and are immediately shipped or hand-delivered using standard chain-of-custody procedures. Environmental soil samples are analyzed for the TALs for each category listed in Section 6.2. Table 6-5 shows which laboratories and which analyses are used for each analyte or analyte group.

Upon receipt, laboratories then air dry each composite sample, disaggregate the entire volume using rotary hammers, and sieve the resultant matrix. Once the samples are dried and sieved, a statistical subsampling procedure is performed to sub-aliquot sample volume for use in the analyses. Moisture samples for field preserved VOC samples are removed from the ISM samples prior to any drying.

Soil samples collected for VOC analysis are field-preserved as described in Section 6.3.3 and are prepped for analysis upon receipt by the lab in accordance with U.S. EPA Method 5035. Table 6-5 lists the laboratories and methods.

6.4 Statistical Evaluation and Screening of Data

Basic summary statistics are prepared for the soil results from DUs located in the same geographic zone/sub-zone and/or sampling event. These tables include common statistical parameters such as mean, standard deviation, minimum and maximum detected values, and minimum and maximum reporting limits (RLs) of non-detects (NDs). The number of samples and detection rates are also included to provide information regarding sample size and detection frequency. Additionally, these summary statistic tables present the results of the screening comparison to relevant criteria.

A screening-level evaluation of the data is performed by comparing each data point to non-residential DC criteria (DCC) for soil. EGLE Part 201 December 30, 2013 non-residential DCC for soil are selected whenever available (EGLE, 2013). EPA Regional Screening Levels (RSLs) for industrial soil are selected whenever EGLE screening criteria are not available (document release date: May 2016) (EPA, 2016).

EGLE State-wide default background values are used as an initial screen for metals, when available. EGLE also developed and provided a regional background and modified urban background for some metals during the Midland Area Soil project, which are used as a secondary screen.

For the evaluation of analytes that exist in several isomer forms, the isomer-specific concentrations are summed before being compared to the appropriate screening criteria. These classes of analytes include chlordanes, endosulfans, methylphenols (cresols), polynuclear aromatic hydrocarbons (PAHs), PCBs, and xylenes and are summarized in Table 6-6.

6.5 Zone 1, Campus Area, and Greenbelt Areas Direct Contact to Soil Pathway Summary

Zone 1 represents approximately 300 acres that were evaluated by ISM soil sampling in 2016. Zone 1 encompasses sites such as the 1925 Landfill, LELs II and III, and borders the river (Figure 6-5). The Campus Area and Greenbelt Areas were also included for evaluation in Year 1 in order to expedite sampling in those areas. The following land use categories were sampled in Zone 1, the Campus Area, and the Greenbelt Areas (Figures 6-6 through 6-10):

- Category 1, Laydown Area, Gravel Areas (Historical Process Area) – 11 DUs for Aerial Dispersion and Other Sources TALs;
- Category 2, Gravel Areas, Historic Grass Area, Campus Area, Greenbelt Prior to 2000 – 59 DUs for Aerial Dispersion TAL; 6 of the 58 DUs were in Zone 1, 31 of the 58 DUs were in the Campus Area; 22 of the 58 DUs were Greenbelt Areas;
- Category 3; Greenbelt Areas established after 2000 – 27 DUs for Imported Soil TAL;
- Category 4, Relocated Soils covered with Imported Top Soil – 3 DUs for Imported Soils TAL;
- Category 5, Stormwater Basins – 6 DUs for Imported Soils, Aerial Dispersion via Run-off TALs; and
- Category 6, Vegetated Cap Closed by Dow – 9 DUs for Aerial Dispersion, Leachate Breakout, and Imported Soil TALs.

All non-dioxin results in the Campus Area, Greenbelt Areas, and Zone 1 are below non-residential DCC. All dioxins and furans TEQ results for the Campus and Greenbelt Areas established prior to 2000 are below the non-residential DCC. Therefore, no further action was proposed for the Campus Area and Greenbelt Areas established prior to 2000 upon initial review of the results. However, based on an assessment of the overall site data completed in 2019, Greenbelt Areas established after 2000 and Category 4 DUs will be revisited for dioxin and furan sampling in 2020. The purpose of revisiting these DUs will be discussed in more detail in Section 6.15.

Out of the 32 DUs sampled for dioxins and furans in Zone 1, 17 DUs had dioxins and furans TEQ results below the non-residential DCC (990 ppt). Previously, no further action was deemed appropriate for those 17 DUs (Figure 6-11).

Several of these DUs were subjected to confirmation sampling in 2017 (see Section 6.8) and have had UCLs calculated with the replicate results. The UCL value has now replaced the initial result obtained and that has changed the path forward for some of these DUs. Discussion of the UCL calculations as well as planned interim measures is discussed in more detail in Sections 6.11 and 6.14.1, respectively.

Additionally, another sampling effort was completed in late 2019 based on the lower confidence level discussion in Section 6.8 and the reassessment of the stormwater basin conceptual model for the site in Section 6.13. The full evaluation of the fall 2019 data is not be available for this CAIP submittal; however, it will be shared during one of the monthly Dow/EGLE Corrective Action meetings and will be summarized in the 2020/2021 CAIP.

Based on the DUs with elevated dioxins and furans TEQ results, the following DUs were identified for further evaluation in 2016:

- Category 1, Laydown Area, Gravel Areas (Historical Process Area) – Seven DUs were identified with elevated dioxins and furans related to historic Aerial Dispersion (1A-2 through 1A-8) and

- Category 2, Gravel Areas, Historic Grass Areas – Elevated dioxins and furans were identified in one DU (2D).

6.5.1 Zone 1 Interim Measure/Long-Term Barrier Design Sampling

Dioxins and furans TEQ results at the Zone 1 DUs where results exceeded the non-residential DCC warranted further evaluation to complete design work for interim measures or follow-up work in adjacent or similar DUs. The following DUs were part of this additional sampling effort (Figure 6-12):

- DUs in the Pallet Yard Area (1A-2 and 1A-8);
- Stormwater basin DUs that receive stormwater runoff from the Pallet Yard Area (5E-1, 5E-2, 5E-4, 5E-5, and 5E-6);
- Category 1 Laydown Area DUs (1A-9 through 1A-12) near the Pallet Yard Area; and
- DU 2D and an additional nearby DU (4C).

Depth-discrete samples down to 12 inches bgs were collected in 2017 from DUs 1A-2 through 1A-8 to evaluate the thickness of the impacted soil layer. The results of the sampling, presented in the *2017 Corrective Action Implementation Summary Report and 2018 Work Plan*, confirm that over approximately half of the area impacts are within the upper 12 inches. The results from DUs 1A-2, 1A-4, 1A-7, and 1A-8 indicated greater than 12 inches of impacted soils. The specifics of the interim measures implemented along with the long-term barrier constructed for this area will be discussed in Section 6.14.1.1.

There were a few stormwater areas identified as receiving stormwater runoff from the Pallet Yard Area (Figure 6-12). One portion of these stormwater areas (DU 5E-3 shown on Figures 6-10 and 6-11) was sampled among the DUs sampled in 2016, but samples were collected from an additional four DUs that received runoff from the laydown areas (5E-1, 5E-2, 5E-4, and 5E-5). Samples from additional DU 5E-6 were also collected, although a berm separates the noted basin from runoff from the Category 1 areas. The results of the sampling of these stormwater areas, presented in the *2018 Corrective Action Implementation Summary Report and 2019 Work Plan*, confirm that no further action is necessary on these DUs.

Additional Category 1 DUs 1A-9 through 1A-12 were also defined and sampled in areas adjacent to the Pallet Yard (Figure 6-12). Six-inch surficial incremental composite samples were collected from each DU during late 2017. The results of the sampling of these stormwater areas, presented in the *2018 Corrective Action Implementation Summary Report and 2019 Work Plan*, confirm that interim measures or the construction of long-term barriers are warranted. The specifics of the interim measures to be implemented or long-term barriers to be constructed in these areas will be discussed in Section 6.14.1.2.

Higher than expected dioxins and furans TEQ results identified at DU 2D in 2016 were suspected to be from placement of an inadequate thickness of clean topsoil (less than six inches). As such, an additional 0-3-inch ISM soil sample was collected from this DU. A nearby DU (4C) also included soil from similar work as that found at 2D (Figure 6-12). Based on results of the sampling, which were presented in the 2017/2018 CAIP, IMs will be put in place for 2D and 4C and are discussed in Section 6.14.1.3.

6.5.2 Additional Zone 1 DUs Request by EGLE

Areas approved and closed under EGLE and/or EPA oversight were not initially sampled. These areas include the approved RGIS Construction and Upgrade Project, LEL II, Waste Storage Area IIA, Open Waste Water Conduits, 703 Incinerator Area, and the Closed Diversion Basin. Subsequently, EGLE requested specific areas be investigated and limited samples were collected in 2018 from DUs that covered these areas per the CSM. The specific areas included in this sampling were:

- LEL II Final cover;
- Additional evaluation of former fire training area on 1925 Landfill;
- An additional DU from the 8Pond Final Cover; and
- Low-lying areas adjacent to the Wastewater Treatment Plant (WWTP).

In addition to these areas requested by EGLE, a few additional DUs were sampled to evaluate areas found downgradient of DUs with reported dioxins and furans TEQ results higher than 990 ppt in 2018. The 17 additional DUs sampled in 2018 from Zone 1 are shown on Figure 6-13.

One of the areas requested by EGLE includes a former fire training area and will include characterization of soil for Perfluorooctane sulfonic acid and Perfluorooctanoic acid (referred to as PFOS/PFOA) which are common components in certain fire-fighting foaming agents. These emerging contaminants are also contained in several common products, and additional sampling precautions must be taken to prevent inadvertent contamination of environmental samples. In addition, laboratory analytical techniques have not been uniformly adopted for soil; therefore, a specific proposal for this area including the sampling and analytical procedures is in process and will be provided to EGLE prior to sampling according to the schedule in Section 17.0.

All non-dioxin results were less than non-residential DCC in all the sampled DUs across Categories 1, 4, 5, 6, and 7. For the 15 additional Zone 1 DUs sampled in 2018, there were three dioxins and furans TEQ results that exceeded the non-residential DCC of 990 ppt. Figure 6-14 presents the dioxins and furans TEQ results by DU. Out of the five property category types sampled as part of the EGLE-requested DUs in Zone 1, four were analyzed for dioxins and furans TEQ. Only two of the categories had a DU with an exceedance of the non-residential DCC, Categories 1 and 5. Category 1 Laydown Areas and Gravel Areas (Historical Process Areas) demonstrated the highest dioxins and furans TEQ results ranging from 829 ppt to 3,530 ppt, with only two exceedances of the non-residential DCC (1C-2 at 1,120 ppt and 1C-4 at 3,530 ppt). Out of the two Category 5 Stormwater Basin DUs, only one of the results observed was above the non-residential DCC (5A-1 at 1,190 ppt). Categories 6 and 7 did not have any dioxins and furans TEQ results that exceeded the non-residential DCC. The results of 1C-2, 1C-4, and 5A-1 indicate the need for the implementation of an interim measure and the interim measures will be discussed in detail in Section 6.14.1.

Another sampling effort was completed in late 2019 based on the lower confidence level discussion in Section 6.8 and the reassessment of the stormwater basin conceptual model for the site in Section 6.13. The full evaluation of the fall 2019 data is not available for this CAIP submittal; however, it will be shared during one of the monthly Dow/EGLE Corrective Action meetings and summarized in the 2020/2021 CAIP. The findings of this evaluation may change the path forward for DUs subject to the additional evaluation.

6.6 Zone 2 Direct Contact to Soil Pathway Summary

Zone 2 (Figure 6-15) covers approximately 280 acres and encompasses an area in the east (approximately 245 acres) and a small area in the west of the facility (approximately 35 acres). Zone 2 DUs were initially sampled in 2017 with four additional DUs being sampled for the first time in 2019. The following land use categories were sampled in Zone 2 in 2017:

- Category 1, Laydown Areas and Gravel Areas (Historical Process Areas) – 51 DUs for Aerial Dispersion and Other Sources TALs (note that four of these DUs were sampled in 2019 and will be discussed in detail in Section 6.6.1);
- Category 2, Gravel Areas, Historic Grass Areas – 16 DUs for Aerial Dispersion TAL;

- Category 4, Relocated Soils covered with Imported Top Soil – 6 DUs for Imported Soils TAL; and
- Category 5, Stormwater Basins – 19 DUs for Imported Soils, Aerial Dispersion via Run-off TALs.

In Zone 2, 75 out of the 86 DUs sampled for dioxins and furans had dioxins and furans TEQ results below the non-residential DCC (990 ppt). Therefore, no further action was proposed for those 75 DUs in 2017. Several of these DUs were subject to confirmation sampling in 2018 (Section 6.8) and have had UCLs calculated with the replicate results. The calculated UCLs have changed the path forward for some of these DUs. Discussion of the UCL calculations as well as planned interim measures are discussed in more detail in Sections 6.11 and 6.14.1, respectively.

Additionally, another sampling effort was completed in late 2019 based on the lower confidence level discussion in Section 6.8 and the reassessment of the stormwater basin conceptual model for the site in Section 6.13. The full evaluation of the fall 2019 data is not be available for this CAIP submittal; however, it will be shared during one of the monthly Dow/EGLE Corrective Action meetings and will be summarized in the 2020/2021 CAIP.

Based on dioxins and furans TEQ and arsenic results, the following were identified for implementation of IMs and/or additional design sampling to facilitate the construction of long-term barriers in 2017:

- Category 1, Laydown Area, Gravel Areas (Historical Process Areas) (Figures 6-16 and 6-17) – Eleven (11) DUs were identified with elevated dioxins and furans;
- Category 2, Historic Grass and Gravel Areas (Figure 6-18) – One arsenic result was greater than the non-residential DCC. (2A at 41 mg/kg). The dioxins and furans TEQ result was elevated in that same DU and at six nearby DUs.

Depth-discrete dioxin and furan ISM soil sampling was completed at DUs located around 499 Building (Figure 6-19) that had elevated dioxins and furans TEQ results in 2017. DUs 1S5, 1S6, 1S7, and 1S8 were added to this effort. These depth-discrete samples were collected to support design work and the results were presented in the *2017 Corrective Action Implementation Summary Report and 2018 Work Plan*. The results confirmed that impacts continue to be present at a depth of at least 3 ft below the existing grade over most of the area covered by the noted DUs. The details of the long-term barrier put in place at these DUs is discussed in detail in Section 6.14.2.1.

The non-residential DCC exceedances observed at eastern Zone 2 DUs 1V2 and 1GG2 (Figure 6-17) along with the exceedances observed in the western Zone 2 Category 2 DUs indicate interim measures are warranted. The details of the interim measures implemented/to be implemented or the long-term barrier constructed these DUs will be discussed in more detail in Section 6.14.2.2.

Railroad property adjacent to proposed IMs for the Zone 2 Laydown Yard was evaluated by ISM soil sampling in October/November 2017. These eight DUs were categorized as a Category 1 property type and were sampled for the aerial dispersion and other sources TALs per Section 6.2. Figure 6-20 presents the Railroad DUs along with their respective dioxins and furans TEQ result. For the eight Category 1 Railroad DUs, all non-dioxin results were below the non-residential DCC in Category 1; however, six out of the eight Zone 2 Railroad DUs sampled had dioxins and furans TEQ results greater than the non-residential DCC of 990 ppt. The dioxins and furans TEQ results ranged from 304 ppt – 52,100 ppt. The second highest result, 3,830 ppt, was observed at DU 1B4. The Railroad DU 1B1 (with a dioxins and furans TEQ result of 52,100 ppt) was addressed at the same time as the IMs planned for the eastern Zone 2/499 IM Area, which will be discussed in further detail in Section 6.14.2.1. The five remaining Zone 2 Category 1 Railroad DUs with dioxin and furan TEQ results above the non-residential DCC warrant interim measures and the details of the IMs will be discussed in Section 6.14.2.

6.6.1 Zone 2 Direct Contact to Soil Pathway Summary for 2019 DUs

Four additional Category 1 DUs were sampled in 2019 in Zone 2 (Figure 6-21). Previously, two DUs in this area known as DUs 1B and 1D were not sampled in 2017 due to access issues (shown in hatched shading on Figure 6-18). In 2018, the existing structures in the area were demolished. These areas were then sampled as DUs 1-45 and 1-47 in 2019. Additionally, in 2019, DU 1B was sampled as part of DU 1-46 and DU 1D was sampled as part of 1-44. These additional DUs were sampled and analyzed based on the TAL determination provided in Section 6.2 and were sampled using the new increment sampling location count noted in Section 6.3.2, which is discussed in further detail in Section 6.8.

Table 6-7 presents the summary statistics for dioxins and furans TEQ and Table 6-8 presents the dioxins and furans TEQ results by DU. The dioxins and furans TEQ results are also shown on Figure 6-22. Metals results and totals evaluations are presented on Tables 6-9 and 6-10, respectively. The non-dioxin summary statistics and screening comparison are shown in Table 6-11.

All non-dioxin results were less than non-residential DCC. Three out of these four DUs had dioxins and furans TEQ results greater than the non-residential DCC of 990 ppt (with values ranging from 2040 ppt to 2920 ppt). For these three DUs that exceeded the dioxins and furans TEQ non-residential DCC and interim measure will be put in place in 2020 as described in Section 6.14.2.2 and per the schedule presented in Section 17.0. Replicate sampling will be completed on DU 1-46 per the discussion in Section 6.11.

6.7 Zone 3 Direct Contact to Soil Pathway Summary

Zone 3 covers approximately 284 acres and was sampled in 2018. Figure 6-23 shows the DUs and presents the overview of Zone 3, including shading according to property type category. The following land use categories were identified in Zone 3:

- Category 1, Laydown Areas and Gravel Areas (Historical Process Area) – 37 DUs for Aerial Dispersion and Other Sources TALs;
- Category 2, Historic Grass Areas – 19 DUs for Aerial Dispersion TAL;
- Category 4, Relocated Soils covered with Imported Top Soil – 12 DUs for Imported Soils TAL; and
- Category 5, Stormwater Basins – 70 DUs for Imported Soils, Aerial Dispersion via Run-off TALs.

All non-dioxin results in Categories 1, 2 and 4 are below non-residential DCC. Therefore, no further action is proposed at this time to address non-dioxin analytes in Categories 1, 2 and 4. For Category 5, all non-dioxin results, except for two arsenic results, are less than non-residential DCC. In DUs 5EE and 5HH1 (Figure 6-24), arsenic was detected at concentrations (360 mg/kg and 53 mg/kg, respectively) greater than the non-residential DCC (37 mg/kg). Based on these results, these two DUs were sampled in triplicate for arsenic in late 2019. Based on the evaluation to be completed in 2020 of the results of the triplicate analysis, implementation of IM may be required at these DUs.

In Zone 3, out of the 126 DUs sampled and analyzed for dioxins and furans TEQ, results were below the non-residential DCC (990 ppt) in 108 DUs. Therefore, no further action was proposed for those 108 DUs in 2018 (Figure 6-25).

Several of these DUs were subject to confirmation sampling in 2017 (see Section 6.8) and have had UCLs calculated with the replicate results. The UCL value has now replaced the initial result obtained and that has changed the path forward for some of these DUs. Discussion of the UCL calculations as well as planned interim measures are discussed in more detail in Sections 6.11 and 6.14.1, respectively.

Additionally, another sampling effort was completed in late 2019 based on the lower confidence level discussion in Section 6.8 and the reassessment of the stormwater basin conceptual model for the site in Section 6.13. The full evaluation of the fall 2019 data is not be available for this CAIP submittal; however, it will be shared during one of the monthly Dow/EGLE Corrective Action meetings and will be summarized in the 2020/2021 CAIP.

Based on the dioxins and furans TEQ results from 2018, interim measures have been implemented and/or long-term barriers have been constructed at the following five Zone 3 DUs: 1G, 1Q, 1U1, 1U2, and 5KK. Section 6.14.3 presents the IM activities completed to date at these DUs as well as the additional sampling completed in the fall of 2019 at DUs 1Q and 5KK to better determine the next steps with regards to IMs or long-term barriers to be completed. For the remaining 13 DUs with exceedances of the dioxins and furans TEQ non-residential DCC, the implementation of interim measures will also be discussed in Section 6.14.3.

6.8 Evaluation of Dioxins and Furans Replicate Sampling From Zone 1 and Zone 2

Ten percent of DUs from Zone 1 and Zone 2 were sampled in triplicate sampling and tested by EPA Method 1613b in 2017 and 2018, respectively. DUs for this evaluation were selected with concentrations closest to the non-residential DCC. The locations of the Zone 1 and 2 DUs selected are shown in Figure 6-26 and Figure 6-27, respectively. For the DUs selected, the original sample was retained from 2016 (Zone 1) and 2017 (Zone 2), and two additional replicates were obtained from each of the original increment locations in 2017 (Zone 1) and 2018 (Zone 2). The original sample and two replicates were then analyzed by EPA Method 1613b. Results for the Zone 1 and Zone 2 confirmation sampling are summarized in Table 6-12 and Table 6-13. The average relative standard deviation of the mean (RSD) of the triplicate sets for Zone 1 through Zone 2 is 24% (19% and 29%, respectively). While this RSD is acceptable, Dow proposed increasing the number of increment sampling locations as part of adaptive management in response to this assessment. The number of increment sampling locations was increased for any new DU to be sampled in the direct contact assessment for the facility starting in 2019. The breakdown of the increment increases is listed below:

- DUs less than 0.5-acre increased from 10 increment to 20 increment sampling locations;
- DUs greater than 0.5-acre and less than 1 acre increased from 20 increment to 30 increment sampling locations; and/or
- DUs greater than 1 acre increased from 30 increment to 50 increment sampling locations.

Increasing the number of increments can lessen the variability between replicates/improve precision (ITRC, 2012). EGLE accepted this change on May 21, 2019 but requested that the 10% replicate sampling in Zone 4 include the triplicate analysis of the previous increment count as well as the 2018 increment changes in order to demonstrate the standard deviation changes associated with the increment changes. Replicate sampling completed in Zone 4 in 2019 is discussed in more detail in Section 6.11.

In addition to evaluating the precision of the sampling methodology, a comparison between the Midland FAST results and the 1613b results for the primary replicate for each Zone 1 and Zone 2 DU collected in triplicate (Figure 6-28 and Figure 6-29) was conducted to assess the accuracy of the Midland FAST methodology. The linear regression showed that the Midland FAST analysis is accurate and unbiased, with an R^2 value of 0.99 for each the Zone 1 and Zone 2 data sets. The regression analysis showed that the Midland FAST method conservatively “overestimates” the result for the replicate when compared to the 1613b results for the same sample by 56 ppt for the combined data sets (39 ppt and 73 ppt for Zone 1 and Zone 2, respectively).

Considering the average RSDs of Zone 1 and Zone 2 replicate results for dioxins and furans, the data sets for Zone 1 through Zone 2 along with the RSD were used to determine a 95% lower confidence level

of 610 ppt of the Midland FAST results (Table 6-14). The 95% lower confidence levels dependent on DU size/number of sampling increment locations ranged from 550-610 ppt. As a result of this evaluation all DUs between 550 ppt and 990 ppt that were not previously evaluated via confirmation sampling for dioxins and furans were resampled in triplicate using the new increment counts established in 2019 to confidently determine that the dioxins and furans TEQ results for these DUs were below non-residential DCC. This sampling work was completed in the fourth quarter of 2019; therefore the results from this sampling will not be fully evaluated in time for this CAIP submittal. The result will be shared during one of the monthly Corrective Action meetings in 2020 and summarized in the 2020 CAIP. The DUs included in this sampling effort are shown in Figure 6-30 and Table 6-15.

Additionally, as replicate data is available for the DUs that were part of this confirmation sampling analysis, UCLs were developed for these DUs in 2019. The full discussion of the UCLs will be presented in Section 6.12. The UCLs will be used to determine the path forward for a DU in terms of whether no further action is necessary or interim measures need to be taken while determining if a long-term barrier is needed for the DU; therefore the previous path forward for a DU may change.

6.9 Arsenic Replicate Sampling

Arsenic is the only other analyte that has observed exceedances of non-residential DCC in sampling completed in Zones 1 through 3, specifically in Zones 2 and 3. Although replicate sampling of arsenic throughout each zone has not been completed, the average RSD developed for the dioxins and furans TEQ results from Zone 1 and 2 was used to conservatively estimate a 95% lower confidence level for arsenic. As a result, all DUs that exceeded this 95% lower confidence level for arsenic were sampled in triplicate using the new increment counts established in Section 6.8 to confidently determine that these DUs were either truly below non-residential DCC for arsenic. These DUs are shown on Figure 6-31 (with their respective arsenic concentration prior to the fall sampling event) and Table 6-15. As this sampling was completed in late 2019 the full evaluation of the results is available for this CAIP submittal but will be presented during one of the monthly Dow/EGLE Corrective Action meetings and will be summarized in the 2020/2021 CAIP.

6.10 Zone 4 Direct Contact to Soil Pathway

For Year 4 of the DC assessment, Zone 4 was evaluated which covers approximately 424 acres (Figure 6-32). The following sections discuss the exposure characterization, target analytes, sampling methods and activities, analytical results, and the path forward determined for Zone 4.

6.10.1 Zone 4 Characterization

An overview of Zone 4, including the shading according to property type category, is shown in Figure 6-33. Figure 6-33 also shows the proposed DUs. Table 6-16 presents the overview of Zone 4, including shading according to property type category. Individual sample plans were developed for each DU and are included in Appendix E. The following land use categories were identified in Zone 4:

- Category 1, Laydown Areas – 41 DUs for Aerial Dispersion and Other Sources TALs;
- Category 2, Historic Grass Areas – 97 DUs for Aerial Dispersion TAL;
- Category 5, Stormwater Basins – 8 DUs for Imported Soils, Aerial Dispersion via Run-off TALs; and
- Category 6, Vegetated Cap Closed by Dow – 24 DUs for Aerial Dispersion, Leachate Breakout, and Imported Soil TALs.

All four possible sources outlined in Section 6.2 were identified in Zone 4. These include aerial dispersion, imported soils, leachate breakout determined from RGIS detections for vegetated landfill caps and other sources (e.g., point source release, historic area operations). The prescribed TALs for each exposure category described in Section 6.2 were implemented for the 2019 sampling of Zone 4.

Table 6-18 presents those DUs with increments moved due to obstructions and a list of DUs with documentation for why the DU was not be sampled. Only one DU out of the 170 proposed DUs was not sampled, Z4-1-27, due to active movement of soil within the DU during the summer sampling event.

Seventeen Zone 4 DUs (Figure 6-34 and Table 6-16) were collected in triplicate using the new increment sampling location count outlined in Section 6.8. These 17 DUs were also collected in triplicate using the old increment count outlined in Section 6.3.2. Category 1 and 6 DUs were chosen for this exercise because conceptually areas that are placed in these two categories are more likely to have elevated dioxins and furans TEQ results. For the purposes of evaluating the data in this section, all initial FAST results will be discussed. The complete evaluation of this replicate testing will be discussed in detail in Section 6.11 and the resulting UCL evaluation in Section 6.12.

6.10.2 2019 Zone 4 Direct Contact Sampling Results and Evaluation

For Zone 4, ISM soil sampling activities were conducted in May through August 2019 for 169 DUs in areas immediately within the Michigan Operations facility. The results are presented by category below. Table 6-18 presents the summary statistics for dioxins and furans TEQ for Categories 1, 2, 5 and 6; and Table 6-19 presents the dioxins and furans TEQ results by DU. Metals results compared to background levels and totals evaluation are presented on Tables 6-20 and 6-21, respectively. The analytical data from this evaluation are presented in Appendix F.

6.10.2.1 Category 1 - Laydown Areas and Historical Areas Operations (Gravel Areas)

For Category 1, 40 DUs were sampled and analyzed for the Aerial Dispersion and Other Source TALs. Table 6-22 presents the summary statistics for the non-dioxin results for Category 1 DUs. All non-dioxin results were below the non-residential DCC in Category 1. As shown in Tables 6-18 and 6-19, two out of the 40 DUs sampled in Category 1 had dioxins and furans TEQ results greater than the non-residential DCC of 990 ppt (Z4-1-3 at 1840 ppt and Z4-1-11 at 1110 ppt). Neither of these DUs were sampled in triplicate in 2019.

6.10.2.2 Category 2 - Historic Grass and Gravel Areas

A total of 97 Category 2 DUs were sampled and analyzed for the aerial dispersion TAL. Table 6-23 presents the summary statistics for arsenic for Category 2 DUs. All arsenic results were well below the non-residential DCC (37 ppt). As shown in Tables 6-18 and 6-19, two of the 97 DUs had dioxins and furans TEQ results greater than 990 ppt (Z4-2-76 at 3750 ppt and Z4-2-77 at 1710 ppt). Neither of these DUS were sampled in triplicate in 2019.

6.10.2.3 Category 5 - Stormwater Basin

Eight Category 5 DUs were sampled and analyzed for the Imported Soils and Aerial Dispersion via Run-off TALs. Table 6-24 presents the summary statistics for non-dioxin analytes for Category 5. All non-dioxin results are less than non-residential DCC. As shown in Tables 6-18 and 6-19, all dioxins and furans TEQ results are less than 990 ppt (the highest dioxin and furan result from this category was 375 ppt at Z4-5-8). As no results from the Zone 4 Category 5 DUs exceed non-residential DCC, no further action is proposed at this time for Zone 4 Category 5 DUs.

6.10.2.4 Category 6 - Vegetated Cap Closed by Dow

A total of 24 Category 6 DUs were sampled and analyzed for the Imported Soil TAL. Table 6-25 presents the non-dioxin summary statistics for Category 6. All results are less than non-residential DCC. Additionally, Tables 6-18 and 6-19 show that all dioxin and furan results are less than 990 ppt. Therefore, no further action is proposed at this time for Zone 4 Category 6 DUs.

6.10.3 Zone 4 Results Evaluation

All non-dioxin results from Zone 4 Categories 1, 2, 5 and 6 DUs sampled in 2019 were less than the non-residential DCC.

In Zone 4, Category 1, 2, 5 and 6 DUs were sampled and analyzed for dioxins and furans TEQ. Figure 6-35 presents the dioxins and furans TEQ results by DU. Only two of the four property type categories sampled and analyzed for dioxins and furans had DUs with dioxins and furans TEQ exceedances of the respective non-residential DCC (990 ppt) (Categories 1 and 2). Of the four categories sampled and analyzed in Zone 4 for dioxins and furans TEQ, Category 2 Historic Grass and Gravel Areas demonstrated the highest dioxins and furans TEQ results ranging from 12.2 – 3,750 ppt, with only two DUs with results exceeding 990 ppt. Category 1 dioxins and furans TEQ results ranged from 23.2 ppt – 1,840 ppt, also with only two DUs exceeding 990 ppt. Category 5 dioxins and furans TEQ results ranged from 17.8 ppt to 375 ppt and the dioxins and furans TEQ results for Category 6 ranged from 8.08 ppt – 265 ppt.

6.10.4 Zone 4 Summary and Recommendations

All non-dioxin results in Categories 1, 2, 5 and 6 are below non-residential DC. Therefore, no further action is proposed at this time to address non-dioxin analytes in Categories 1, 2, 5 and 6.

In Zone 4, out of the 169 DUs sampled and analyzed for dioxins and furans TEQ, results were below the non-residential DCC (990 ppt) in 165 DUs. For 161 of 165 DUs, no further action is proposed. Four of these DUs (Z4-1-2, Z4-1-4, Z4-1-5 and Z4-1-39) will be sampled in triplicate for dioxins and furans in 2020 based on the replicate discussion in Section 6.11

Based on dioxins and furans TEQ results, two Category 1 DUs and two Category 2 DUs have results exceeding 990 ppt: Z4-1-3 (1,840 ppt), Z4-1-11 (1,110 ppt), Z-2-76 (3,750 ppt), Z4-2-77 (1,710 ppt). Section 6.14.4 presents the interim measure activities to be undertaken to address these DUs. The anticipated schedule for the interim measures to be implemented is included in Section 17.0.

6.11 2019 Replicate Sampling Evaluation

Replicate sampling was completed in Zones 3 and 4 in 2019. This replicate sampling was done to:

- 1) Perform routine Zone 3 confirmation sampling by sampling 10% of the DUs with dioxins and furans TEQ results closest to the non-residential DCC in order to accurately confirm their results; and
- 2) Assess if increasing the number of increment sampling locations increases the precision of the results and to further confirm that the Midland FAST analytical method is accurate when compared to the 1613b method for determining the dioxins and furans TEQ result for given DU.

Tables 6-26 and 6-27 provide a summary of the assessment described below. These tables also include the results determined from a similar evaluation completed on the Zone 1 and 2 replicate results discussed in Section 6.8. Figure 6-36 also shows a flow chart of how these replicates were sampled and analyzed for dioxins and furans.

RSD/Precision Evaluation

In 2019, DUs from Zone 3 were selected at an approximate frequency of 10% for triplicate sampling and tested by EPA Method 1613b as was done for Zone 1 and Zone 2. DUs for this evaluation were selected with dioxins and furans TEQ results closest to the non-residential DCC. The locations of the Zone 3 DUs selected are shown in Figure 6-37. Differently from Zone 1 and Zone 2, these Zone 3 DUs were resampled entirely in triplicate in 2019 (Zone 1 and Zone 2 DUs retained the original replicate and analyzed it for 1613b). The Zone 3 replicates were analyzed via the Midland FAST analytical method as well as via Method 1613b. The old increment sampling location scheme (i.e., 10, 20, 30 increments) was retained for these replicates in order to have a comparison of Midland FAST replicates and 1613b replicates using the old increment sampling scheme.

The RSD of the Zone 3 replicates was 41% for both the Midland FAST and 1613b analyses. Table 6-28 shows the RSD for each set of replicates from Zone 3. If the high RSD from DU 5C2 is removed from the dataset, the average RSD for the dataset decreases to 31% for both the Midland FAST and 1613b analyses. If this adjusted data set (i.e., removing the RSD for DU 5C2) is included with the Zone 1 and Zone 2 RSD evaluation, the average RSD of replicate sampling using the “old” increment sampling location scheme and 1613b analysis is 27%, but if the replicate set from 5C2 is included, the average RSD increases to 31%. Note that the replicate results of Zone 3 DU 5C2 will be discussed in more detail in Sections 6.12.13, 6.13, and 6.14.4 and interim measures taken to address this DU will be discussed in Section 6.14.4. The Zone 3 confirmation sampling confirms that the “old” increment sampling location still has an acceptable average RSD indicating the precision of the sampling methodologies being implemented for the direct contact assessment is acceptable.

The locations of the Zone 4 DUs selected for this evaluation are shown in Figure 6-34. Category 1 and Category 6 DUs were predominantly chosen due to the likelihood of seeing higher detections in these DUs based on the Midland Facility Direct Contact CSM. Figure 6-36 provides a flow chart that summarizes the breakdown of how each set of the Zone 4 replicates were handled in terms of analytical methods used. Approximately 10% of the Zone 4 DUs were sampled in triplicate twice for dioxins and furans analysis: one set of replicates was completed using the “old” increment sample location scheme (i.e., 10, 20, 30) and the second set of replicates was sampled using the “new” increment sample location scheme (20, 30, 50).

The sets of Zone 4 replicates collected using the “new” increment (2019) counts were analyzed via both the Midland FAST analytical method and 1613b to compare whether the RSD between identically sampled replicate sets is impacted by the analytical method used. The sets of Zone 4 replicates collected using the old increment sampling location scheme were analyzed via the Midland FAST analytical method.

The “old” versus “new” increment amounts sampling comparison was done with the applicable Zone 4 replicate analyzes via the Midland FAST method to assess if increasing the number of increment sampling locations would decrease the average RSD. The RSDs for each replicate set for Zone 4 are shown in Table 6-29. The average RSD for the replicates collected using the old increment sampling location scheme analyzed using the Midland FAST method was 13% and the average RSD for the replicates collected using the new increment sampling location scheme analyzed using the Midland FAST method was 12%. The very slight difference in RSD observed between these two data sets indicating that increasing the number of increment sampling locations in a decision very slightly increases precision. The average RSD for the Zone 4 replicate sets collected using the “new” increment sampling location scheme that were analyzed via 1613b is 13%, which is only slightly higher than the RSD for the same samples subjected to the Midland FAST analysis; thus indicating analytical methodology does not have an impact on precision.

When the RSD for the replicates sampled using the “new” increment sampling location scheme in Zone 4 that were analyzed via 1613b is compared to the RSDs determined from replicate sets collected using the “old” increment sampling location scheme that were analyzed by 1613b in Zones 1 and 2 and to the replicate sets from Zone 3 analyzed via 1613b, the RSD has decreased; however, this difference in RSDs

is more likely attributable to the lower concentrations observed in the Zone 4 replicates than due to the increase in increment sampling locations among the Zone 4 DUs when compared to Zones 1 through 3.

Linear Regression/Accuracy Evaluation

In addition to evaluating the precision of the sampling methodology, a comparison between the Midland FAST results and the 1613b results for the DUs in Zone 3 collected in triplicate in 2019 and the Zone 4 DUs sampled in triplicate in 2019 was completed to assess the accuracy of the Midland FAST method. The graph of the Midland FAST vs. 1613b data sets are shown in Figure 6-38 and Figure 6-39, respectively. The regression analyses show the Midland FAST analysis is accurate and unbiased, with R^2 values of 0.98 (Zone 4) and 0.99 (Zone 3), which is comparable to the R^2 values determined for the Zone 1 (0.99) and Zone 2 (0.99) data sets.

The Midland FAST method conservatively “overestimated” the result when compared to the 1613b result for a given replicate sample in Zone 4 by 4 ppt on average. However, for Zone 3 the Midland FAST analysis “underestimated” the result for a given replicate by 810 ppt on average. The difference between the Midland FAST and 1613b results for the duplicate sample for DU 5C2 is 35,000 ppt (as they are 169,000 ppt and 204,000 ppt, respectively). When this pair of results is removed from the data set, the “underestimate” of 810 ppt changes to an “overestimate” of 24 ppt when comparing Midland FAST results to 1613b results for the Zone 3 replicate sets. Comparatively, the Zone 1 and Zone 2 data sets showed that the Midland FAST method conservatively “overestimates” the result for the replicate when compared to the 1613b by 39 ppt and 73 ppt, respectively. Again, note that the replicate results of Zone 3 DU 5C2 will be discussed in more detail in Sections 6.12.13, 6.13, and 6.14.4 and interim measures taken to address this DU will be discussed in Section 6.14.4

Lower Confidence Level Evaluation

The average RSD and linear regression from each zonal data set was used to determine a 95% lower confidence level of the Midland FAST method (Table 6-28). The only zonal data set not included was the Zone 4 “old” increment sampling location data set as these Midland FAST results do not have “paired” 1613b results. The 95% lower confidence level for each of the zones ranged from 450 ppt (Zone 3) to 852 ppt (Zone 4). The Zone 4 95% lower confidence limit is greater than the value calculated for the other zones as much of the data set contained lower concentrations in comparison. A 95% lower confidence level was also determined from an average RSD and linear regression completed with all the applicable data sets. The 95% lower confidence level calculated for the combined data set is 595 ppt, still indicating that all DUs with results from 550 ppt to 990 ppt will be confirmed with replicate sampling to determine if the dioxins and furans TEQ result for the given DU is truly less than 990 ppt.

As a result of the evaluation of the Zone 1 and Zone 2 replicate sampling (discussed in Section 6.8), DUs with dioxins and furans results between 550 ppt and 990 ppt in Zones 1 through 3 that were not previously evaluated via replicate sampling for dioxins and furans were resampled in triplicate using the new increment counts established above to confidently determine that these DUs were below non-residential DCC for dioxins and furans in 2019 (Table 6-15 and Figure 6-30). This sampling work was completed in the fourth quarter of 2019; therefore the results from this sampling will not be fully evaluated in time for this CAIP submittal. The results will be shared during one of the monthly Corrective Action meetings in 2020 and summarized in the 2020 CAIP. However, since the 2019 replicate sampling evaluation reached a similar conclusion to the Zone 1 and Zone 2 replicate sampling, this same effort will be carried out for any new decision units sampled in 2019 with dioxins and furans TEQ results between 550 and 990 ppt (which will be discussed in more detail in Section 6.15).

Conclusion

Overall, the replicate evaluation from Zone 4 shows that the average RSD between replicates does not dramatically change when increasing the number of increment sampling locations for a DU. Additionally, the Midland FAST analytical method is accurate based on the linear regressions and R^2 values developed from comparing Midland FAST and 1613b results from the same sample. This assessment also shows

that the Midland FAST analysis typically “overestimates” the concentration of a DU when compared to the result from 1613b analytical method of the same sample. However, the 95% lower confidence level determined from the average RSD among Zones 1 through 4 indicates that further sampling is warranted on DUs with dioxins and furans TEQ results greater than 550 ppt to confidently determine if the DU contains dioxins and furans at values less than the non-residential DCC. This fieldwork was completed in the fall of 2019 for Zones 1 through 3 for DUs not previously addressed via replicate sampling. The results of the fall 2019 sampling effort are not yet fully evaluated but will be shared during one of the monthly Dow/EGLE Corrective Action meetings and will be summarized in the 2020/2021 CAIP. DUs that fall within this range in Zone 4 will be sampled and evaluated in 2020 as described in Section 6.15.2.

6.12 Dioxins and Furans TEQ UCL Evaluations

Fifty-one DUs have been sampled in triplicate over the course of sampling Zones 1 through 4 (Figures 6-26, 6-27, 6-34, and 6-37) and have been analyzed via 1613b for dioxins and furans TEQ results as described in Sections 6.8 and 6.11. The 1613b results for these replicates were used to calculate 95% upper confidence limits (UCLs) for these DUs. The UCL resulting from the 1613b replicates for each DU will be used to determine the path forward for the respective DU. The path forward for the DUs in this evaluation are in terms of no further action needed or if an interim measure or long-term barrier needs to be put in place with respect to the non-residential DCC for dioxins and furans TEQ results. Table 6-30 shows the initial Midland FAST result compared to the UCL calculated from the 1613b triplicate results for a given DU. Note that the Midland FAST results listed for the Zone 4 DUs are UCLs as these DUs were sampled in triplicate using the old and new increment sampling location scheme in 2019, respectively; therefore a UCL could be calculated for each replicate set. A UCL was also calculated using 2019 Midland FAST data for the Zone 3 DUs, but the 2018 single Midland FAST result was retained for this comparison as the 2018 result was the driver for replicate sampling and handling of these DUs in terms of their respective paths forward. Figures 6-40 through 6-43 and Table 6-30 shows how the path forward has either remained the same or changed based on this assessment for each DU. The applicable dioxins and furans TEQ summary statistics for Zones 1 through 4 are updated and are presented in Table 6-31 through 6-34.

Out of the 51 DUs sampled in triplicate over the course of the direct contact assessment at the facility, eight of the 51 DUs needed an interim measure implemented based solely on the Midland FAST result/Midland FAST UCL and 43 of those 51 DUs needed no interim measures based on their respective Midland FAST results/Midland FAST UCLs. For 12 of the 51 DUs the UCLs resulting from their 1613b replicate results changed their path regarding the need for an interim measure. One out of those 12 cases reversed the need for an interim measure, and 11 of those 12 cases indicate the respective DU does need an interim measure put in place. Ultimately, when using the UCL values, 18 of the 51 DUs included in this evaluation will need interim measures implemented if they have not been completed to date.

6.12.1 Zone 1 Dioxins and Furans TEQ UCLs Evaluation

For Zone 1 (Figure 6-40), the original Midland FAST result for eight of the 10 DUs collected in triplicate indicate that there is no further action necessary and six of those eight DUs had their UCL validate the same conclusion. Two of those eight DUs, 1B2 and 5C3/5C4, had UCL values instead indicate a need for an interim measure which will be discussed in more detail in Section 6.14.1.

The Midland FAST and UCL of the 1613b replicates of two DUs 1A-8 (1300 ppt and 3200 ppt) and 1B4 (1400 and 1900 ppt) both indicate the need for interim measures to be completed at these DUs. DU 1A-8 has already been addressed via the Zone 1 Pallet Yard Area interim measure (discussed in more detail in Section 6.14.1.1). Decision unit 1B4 will need to an interim measure implemented and will be described in more detail in Section 6.14.1. Although the Midland FAST result and UCL for DU 1B3 indicate no further action is needed, it is located between DUs 1B2 and 1B4 and was arbitrarily separated from those DUs based off acreage; therefore it will also be included in the effort to establish the interim measure at 1B2 and 1B4.

6.12.2 Zone 2 Dioxins and Furans TEQ UCLs Evaluation

Nine of the 10 Zone 2 DUs sampled in triplicate for 1613b analysis (Figure 6-41) had Midland FAST results that indicated no further action was necessary. However, three of those DUs had UCLs from their 1613b replicate data show an interim measure are necessary (1,200 ppt at 1BB2, 2,300 ppt at 1Y1, and 1,200 ppt at 2E). The Midland FAST result (1,200 ppt) and UCL determined from the 1613b replicate results (1,400 ppt) for DU 1V2 both indicate a need for an interim measure to be implemented. The additional interim measures needed on the noted Zone 2 DUs will be discussed in further detail in Section 6.14.2.

6.12.3 Zone 3 Dioxins and Furans TEQ UCLs Evaluation

Out of the 15 Zone 3 DUs sampled in triplicate for 1613b analysis (Figure 6-42), 10 of the DUs had Midland FAST results indicating no further action was warranted with respect to dioxins and furans. Four of these 10 DUs had the determination of no further action necessary supported by the UCL determined from their 1613b replicate samples (5A, 1N, 1O1, and 2I). One of the DUs (5LL) had a Midland FAST result (1,400 ppt) that indicated a need for an interim measure, but the UCL of the 1613b replicates (890 ppt) indicate that no further action is necessary.

Six of the DUs had Midland FAST results that indicated no further action was necessary; however, the UCL of the 1613b replicates from these DUs do indicate that an interim measure will be necessary: 1P2 (700 ppt to 1,300 ppt), 1Z (800 ppt to 2,100 ppt), 2C2 (942 ppt to 1,200 ppt), 5C2 (700 ppt to 360,000 ppt), 5F2 (800 to 5,000 ppt), and 5HH1 (1,000 to 1,100 ppt). Note that the RSDs determined for the replicate sample set from DU 5C2 analyzed by Midland FAST and 1613b were both 170%. This DU and the surrounding area were further subdivided and sampled in triplicate for the Category 1 TAL in the Fall of 2019 to determine if a particular area or area adjacent to the DU may have caused the elevated dioxins and furans TEQ results observed (Figure 6-44). The results from the Fall 2019 sampling effort will not be fully evaluated in time for this CAIP submittal but will be shared during one of the 2020 monthly Corrective Action meetings between EGLE and Dow and will be summarized in next year's CAIP. Any additional interim measures required for Zone 3 DUs will be discussed in further detail in Section 6.14.3.

6.12.4 Zone 4 Dioxins and Furans TEQ UCLs Evaluation

Out of the 17 Zone 4 DUs sampled in triplicate for 1613b analysis (Figure 6-43), all the Midland FAST UCLs and UCLs from the 1613b replicates are less than 990 ppt; therefore no further action is necessary on any of these 17 Zone 4 DUs.

6.13 Category 5 Stormwater Basin CSM Evaluation

Based on exceedances observed in stormwater basins (Category 5 DUs) sampled in Zones 1 through 3, a closer evaluation of the CSM for these features was undertaken in 2019. This evaluation was necessary as these features were constructed recently (2009-2011) with clean topsoil sourced several miles away from the facility; therefore exceedances of the non-residential DCC were not expected.

Upon reviewing the data, the rate of sampling of these features was higher than the 20% limited confirmation sampling conceptually presented at the beginning of the direct contact assessment in 2016. Additionally, in some cases decision units were delineated in a manner that was not consistent with the features of interest. As a result of this assessment, 25 additional Category 5 DUs were identified in 2019 for sampling and analysis per the Category 5 TAL. These DUs are shown in Figure 6-45. Increment counts were also increased for these additional DUs sampled in 2019 per the increment counts established in Section 6.8. The analytical lab reports are included in Appendix f.

Furthermore, several Category 5 DUs in Zone 1 DU (5A-2) and Zone 3 (DUs 5KK, 5C2, 5EE, 5R3, 5T1, 5U, and 5HH1) were resampled in the fall of 2019 to:

- Further delineate impacts observed during the initial sampling event or confirmation sampling event, as was the case with Zone 3 DUs 5C2 (Figure 6-44) and 5KK (Figures 6-46 and 6-47) to help design interim measures or long-term barriers,
- To determine if their dioxins and furans TEQ result was truly less than 990 ppt (for Zone 1 DU 5A-2 and Zone 3 DUs 5EE, 5R3, 5T1, and 5U; Figure 6-30)
- To determine if the arsenic result observed in the initial sampling event truly exceeded the non-residential DCC of 37 mg/kg (for Zone 3 DUs 5EE and 5HH1, Figure 6-31).

The results of the fall 2019 sampling effort will not be fully evaluated in time for this CAIP submittal but will be shared during one of the monthly 2020 Corrective Action meetings between Dow and EGLE and will be summarized in the 2020 CAIP.

6.13.1 2019 Sampling Results

Table 6-32 presents the summary statistics for dioxins and furans TEQ results and Table 6-33 presents the dioxins and furans TEQ results by DU. Metals results compared to background levels and totals evaluation are presented on Tables 6-34 and 6-35, respectively. The summary of all non-dioxin results is presented in Table 6-36.

All non-dioxin results are below non-residential DCC. Therefore, no further action is proposed at this time to address non-dioxin analytes. Out of the 25 DUs sampled and analyzed for dioxins and furans TEQ as part of this assessment, dioxins and furans TEQ results were below the non-residential DCC (990 ppt) in 23 DUs. Therefore no further action is proposed for those 23 DUs. Out of the 25 DUs sampled to clarify the stormwater basin conceptual site model, two of the DUs exceeded the non-residential DCC, SW-5J (1,510 ppt) and SW-5W (2,480 ppt).

Section 6.14.4 presents the interim measures to be completed in 2020 to address these two DUs that exceed non-residential DCC. The anticipated schedule for interim measure activities is included in Section 17.0.

Based on the evaluation presented in Section 6.11, stormwater basin DU SW-5H will be sampled in triplicate for dioxins and furans analysis in 2020 to confirm that the dioxins and furans TEQ result for this DU is truly less than 990 ppt.

6.13.2 Conclusion

Across Zones 1 through 4 (and including the two DUs noted above that were sampled in 2019), ten of the 130 Category 5 DUs sampled to date have been identified with dioxins and furans TEQ results or arsenic results greater than the non-residential DCC, including the adjustments made per the UCL evaluation discussed in Section 6.12 (Figure 6-48). Several possible hypotheses were examined in 2019 to determine why these DUs had concentrations of dioxins and furans TEQ greater than the non-residential DCC. Examples of these hypotheses are:

- The boundary of the DUs were not correctly delineating the feature of interest/included areas outside the feature of interest,
- The DUs had an inadequate thickness of clean topsoil; and
- These areas were capturing runoff from areas observed with higher dioxins and furans TEQ results.

Ultimately, the CSM has been updated to show that all stormwater basins/features will be sampled for the facility-wide direct contact assessment and will have interim measures and/or long-term barriers put in place to address any exceedances of the non-residential DCC observed at these DUs.

6.14 Direct Contact Interim Measures and Long-Term Barriers

Through the course of sampling Zones 1 through 4 and through the development of UCLs for DUs sampled in triplicate for dioxins and furans, several DUs have been identified with dioxins and furans TEQ results greater than the non-residential DCC and a few have been identified with arsenic concentrations greater than the respective non-residential DCC. Several areas in Zones 1 through 3 have a long-term barrier in place or have fencing and signage to prevent access to the area with elevated dioxins and furans TEQ results.

The approach to interim measures and long-term barriers taken to address non-residential DCC exceedances is summarized below:

- If the dioxins and furans TEQ result or TEQ UCL for a DU is less than 990 ppt and all other analytes also have results less than their non-residential DCC, no further action is warranted and HE EI is met for these DUs.
- If the dioxins and furans TEQ result or the TEQ UCL for a DU is greater than 990 ppt and/or there are other analytes that exceed their non-residential DCC, fencing and signage with hazard communication and additional PPE usage for workers who need to enter the area will be implemented to achieve HE EI met.
- In some cases where the dioxins and furans TEQ result or the TEQ UCL for a DU is greater than 990 ppt and/or there are other analytes that exceed their non-residential DCC, moving forward with a long-term barrier may be the best approach to achieve HE EI met. A long-term barrier may entail a geotextile covered by gravel or seeded topsoil or asphalt will be used as a cover.

Table 6-37 also summarizes the interim measures taken at the applicable DUs in Zone 1 through Zone 3 and the interim actions that will be taken based on the UCL assessment and results of additional Zone 2 DUs, Category 5 Stormwater Basin DUs, and Zone 4 DUs sampled in 2019.

6.14.1 Zone 1 Interim Measures and Long-Term Barriers

The present status of the interim measures and long-term barriers established for Zone 1 are shown in Figure 6-49 and outlined in Table 6-37.

Dioxins and furans TEQ results for some of the DUs sampled in Zone 1 in 2016 warranted further evaluation to complete design work for IMs or follow-up work in adjacent or similar DUs. The analytical results from the 2017 sampling efforts and the introduction of the path forward regarding interim measures were briefly discussed in Section 6.5.1 and discussed in detail in the *2017 Corrective Action Implementation Summary Report and 2018 Work Plan* for these DUs. The results showed that interim measures and/or long-term barriers were necessary for:

- DUs in the Pallet Yard Area (1A-2 and 1A-8);
- Category 1 Laydown Area DUs (1A-9 through 1A-12) near the Pallet Yard Area; and
- DU 2D and an additional nearby DU (4C).

Two other groups of Zone 1 DUs are also in need of interim measures:

- The UCL assessment summarized in Section 6.12.1 noted Zone 1 DUs 1B2 through 1B4 (a laydown area located near 1159 Building) and DU 5C3/5C4
- Three of the additional Zone 1 DUs sampled per the request of EGLE in 2018 (1C-2, 1C-4, and 5A-1).

Fencing and signage will be installed around these DUs. Results of this sampling will be discussed with workers in the area and the need for additional PPE for workers who must enter and work in the area along with means for proper disposal of the PPE will also be implemented. These interim measures will be implemented per the schedule in Section 17.0.

The following sections summarize the long-term barriers that have been implemented in the Pallet Yard Area and will be implemented in the additional Category 1 DUs near the Pallet Yard Area and DUs 2D and 4C in greater detail.

6.14.1.1 Pallet Yard Area (DUs 1A-2 through 1A-8)

The following describes the timeline of interim measure and long-term barrier implementation in the Pallet Yard Area.

Work Completed in 2016

Access was restricted to the area covered by DUs 1A-2 through 1A-8 by using signage and fencing (Figure 6-50) beginning in 2016. Results and hazard information was provided to the workers in nearby areas. Operations located within the area, including metal recycling and wood pallet grinding and loading were all re-located to other locations within the plant site. In cases where access to the areas was necessary, additional PPE for workers who must enter and work in the area and the means for proper disposal of PPE after use were implemented.

Work Completed in 2017

Depth-discrete sampling was completed at DUs in the Pallet Yard Area (1A-2 and 1A-8) in 2017 to facilitate design work for a long-term barrier.

Work Completed in 2018/Early 2019

In May 2018, Dow provided EGLE with drawings of a long-term barrier for DUs 1A-2 through 1A-8. Dow proposed the placement of a non-woven geotextile visible marker layer to cover with six inches of clean gravel. Included with the submittal of these drawings was a construction-focused soil management and dust track-out plan as some of the existing soil material may needed to be stripped prior to placement of the marker layer and final cover to ensure appropriate sloping and stormwater drainage at the site after installation of the cover. However, during a site walk completed after the submittal of these plans and drawings, Dow identified asbestos on the ground surface and in the soils on part of the area covered by DUs 1A-2 through 1A-8.

Dow reevaluated the approach and the plans were modified to leave the existing soil in place and cover it with a geotextile and a minimum of six inches of gravel placed on top of the geotextile. Dow provided the updated plans to EGLE in September 2018 and EGLE accepted the changes within the same month. Work in the pallet yard area commenced in early November 2018 and was completed by early January 2019. The construction-focused soil management plan and dust-track out control plan submitted and approved in September 2018 was implemented for this construction work.

Work to Be Completed in 2020

A set of as-built drawings will be provided to EGLE in 2020, which will identify the final dimensions of corrective actions, marker layer layout, and thickness and makeup of the final cover layer within each DU.

6.14.1.2 Additional Category 1 DUs Near Pallet Yard Area

The dioxins and furans TEQ results from DUs 1A-9 through 1A-12 indicate the need for an interim measure or long-term barrier to be put in place to address the non-residential DCC exceedances observed at these DUs. The location of DUs 1A-9 through 1A-12 is shown on Figure 6-49. The status of these areas are also summarized on Table 6-37.

Work Completed in 2018-2019

Planning for the long-term barrier was initiated in 2018 for DU 1A-10 and is ongoing. The cover will include either the removal of the top six inches of existing soil, followed by the placement of a non-woven geotextile visible marker layer to be covered by six inches of clean gravel or the area will be covered by asphalt with possible soil removal if warranted by the proof roll. The intention of the soil removal is to ensure appropriate sloping and stormwater drainage in these areas after installation of this long-term barrier. Additional Zone 1 DU 1A-11 will also be included in this effort as the distinction between these two DUs is due to DU acreage/is arbitrary and not due to a physical feature, a change in use, and/or a different historical use.

Work to Be Completed in 2020

The long-term barrier will be put place at DU 1A-10 and 1A-11 in 2020. Construction drawings will be provided to EGLE prior to start of work and work will be completed according to the schedule in Section 17.0 dependent on acceptance of the drawings by EGLE. The construction-focused soil management plan and dust-track out control plan submitted and approved in September 2018 will be implemented during this work. A set of as-built drawings will be provided to EGLE upon completion, which will identify the final dimensions of corrective actions, marker layer layout, and thickness and makeup of the final cover layer within each DU.

Fencing and signage will be installed around DUs 1A-9 and 1A-12. Results of this sampling will be discussed with workers in the area and the need for additional PPE for workers who must enter and work in the area along with means for proper disposal of the PPE will also be implemented. These interim measures will be implemented per the schedule in Section 17.0.

6.14.1.3 Zone 1 DUs 2D and 4C

The additional depth-discrete sampling at DUs 2D and 4C showed that the dioxins and furans TEQ results exceeding non-residential DCC required an interim measure or long-term barrier. The location of DUs 2D and 4C is shown on Figure 6-49. The status of these areas is also summarized on Table 6-37.

Work Completed in 2017-2019

Due to the slope and lack of use of 4C, the interim measure proposed included a barrier and signage to limit exposure to these DUs. The same interim measure was proposed for 2D; however, upon closer examination of DU 2D 2019, a long-term barrier will be constructed which will include the removal of the top six inches of existing soil, followed by the placement of a non-woven geotextile visible marker layer to be covered by six inches of clean top soil prior to revegetation. The intention of the soil removal is to ensure appropriate sloping and stormwater drainage in the area after installation of the cover. A construction drawing for 2D was provided to EGLE in October 2019. Construction will commence once acceptance of the drawings by EGLE is received.

Work to Be Completed in 2020

Construction activities will be completed in accordance with the milestone schedule provided in Section 17.0 pending EGLE acceptance/approval of the drawings provided in 2019. The construction-focused soil management plan and dust-track out control plan submitted and approved in September 2018 will be implemented during the work completed at DU 2D. A set of as-built drawings will be provided to EGLE upon completion for 2D, which will identify the final dimensions of the corrective actions, marker layer layout, thickness, and makeup of the final cover layers within the DU. Fencing and signage will also be installed around DU 4C in 2020 per the schedule outlined in Section 17.0.

6.14.2 Zone 2 Interim Measures and Long-Term Barriers

The 2017 sampling effort of Zone 2 indicated two main areas that required either an interim measure or long-term barrier to be put in place:

- Category 1 DUs near 499 Building (Eastern Zone 2 IM Area, Figure 6-51)
- Category 2 DUs in the western portion of Zone 2 between G Street, H Street, 9th Street, and 10th Street (Western Zone 2 IM Area, Figure 6-52)

Other Zone 2 DUs also warrant interim measures:

- Two additional Zone 2 DUs on the eastern side of the facility, 1V2 and 1GG2 (Figure 6-51),
- Three DUs from the UCL evaluation presented in Section 6.12.2 (1BB2, 1Y1, and 2E, Figure 6-51),
- Five DUs from the sampling completed along the railroad in 2018 (1B2, 1B4, 1B5, 1B7, and 1B8, Figure 6-51), and
- Three DUs sampled in 2019 near the western portion of Zone 2 (1-44, 1-45, and 1-47, Figure 6-52);

These additional areas will require fencing as an IM. The fencing will be installed in accordance with the milestone schedule provided in Section 17.0. Results and hazard information will be provided to the workers in nearby areas. In cases where access to these areas is necessary, additional PPE for workers who must enter and work in the area and the means for proper disposal of PPE will be communicated and implemented.

6.14.2.1 Eastern Zone 2 Long-Term Barrier (499 Area)

The general 499 area is shown in Figure 6-51. Depth-discrete sampling completed in the 499 Area, which was briefly described in Section 6.6 and more thoroughly described in the *2017 Corrective Action Implementation Summary Report and 2018 Work Plan*, further confirmed the need for a long-term barrier in the 499 Area DUs. The status of this area is also summarized on Table 6-37.

Work Completed in 2017

Barricades were placed around one of the DUs (1S3). Contact with the existing soil at DUs 1S1, 1S2, 1S3, and 1S5 through 1S8 was mitigated by placing six inches of new stone and/or gravel cover over the existing soil. For DUs 1S1, 1S2, 1S3, 1S5, 1S6 and 1S8, a stone mix aggregate, which included a significant fine fraction, was utilized and the cover was compacted to approximately four inches to protect the cover to allow for traffic and vehicle use. For DU 1S7, a stone aggregate was used to prevent contact with the existing soil; however, it was not compacted as little to no vehicle traffic or parking is anticipated in that area. These actions were also completed in August of 2017.

Work Completed in 2018

Construction drawings for this area, as well as for the nearby Railroad DU 1B1, were supplied to EGLE on December 21, 2018. EGLE accepted these plans in the first quarter of 2019.

Work Completed in 2019

A long-term barrier consisting of a non-woven geotextile visible marker layer covered by six inches of clean gravel was put in place in 2019. The clean compacted gravel placed in 2017 at the DUs noted above, along with six inches of the underlying pre-existing gravel, was removed in order to maintain the grade from prior to the addition of gravel in 2017. At DUs 1T1 through 1T3, where no gravel was placed in 2017, only six inches of pre-existing gravel was removed prior to the laying of the marker layer and clean compacted gravel. The Railroad DU 1B1 (with a dioxins and furans TEQ result of 52,100 ppt) was also addressed at the same time as the IMs for the eastern Zone 2 IM Area and was handled in the same manner as DUs 1T1 through 1T3. The construction-focused soil management plan and dust-track out control plan submitted and approved in September 2018 was implemented during this work. The construction work for these areas was completed in October 2019.

Work to Be Completed in 2020

Of note, a small area in the western portion of 1S4 was covered with a parking lot for the occupants in 499 Building in lieu of the gravel cover being used for the rest of the DU. Additionally, the remainder of 1S4 has not been addressed as an upcoming water main installation project will be disturbing the area in the very near future. This remaining portion of DU 1S4 is presently fenced off with signage until the water main installation is complete and the proposed barrier can be put in place. The remainder of DU 1S4 will be handled as 1T1 through 1T3 were addressed as no gravel was placed on the DU in 2017 and the construction-focused soil management plan and dust-track out control plan submitted and approved in September 2018 will also be implemented during this work.

Construction activity will be completed for the remaining work in accordance with the milestone schedule provided in Section 17.0 pending completion of the water main installation project. A set of as-built drawings will be provided to EGLE upon completion, which will identify the final dimensions of the corrective actions, marker layer layout, thickness, and makeup of the final cover layers within each DU.

6.14.2.2 Western Zone 2 Long-Term Barrier

A small number of DUs in the western portions of Zone 2 (2A-2D, 2H and 2G) were identified with elevated dioxins and furans TEQ results, as well as one DU (2A) that included both a dioxins and furans TEQ result and a concentration of arsenic above the non-residential DCC (Figure 6-52). The status of these areas is also summarized on Table 6-37.

Work Completed in 2018

In late October 2018, results and hazard information was provided to the workers in nearby areas. In cases where access to these areas was necessary, the proper use and disposal of PPE to mitigate exposure via ingestion for workers who must enter and work in these areas was also discussed.

Work Completed in 2019

Construction drawings for a long-term barrier for these areas were provided to EGLE on August 15th, 2019 and were reviewed and accepted by EGLE on September 4th, 2019. Work commenced on these areas in October 2019 and was completed in November 2019. These areas were first proof rolled, but if the proof roll was deemed not acceptable an additional 6" of soil was removed. The areas were then covered with approximately 2.5" of asphalt leveling course and then covered with 1.5" of asphalt top course. The construction-focused soil management plan and dust-track out control plan submitted and approved in September 2018 was used during the implementation of this work. Any soils removed were taken to Salzburg Landfill in lieu of Dow 6-Pond.

Work to Be Completed in 2020

A set of as-built drawings will be provided to EGLE in 2020, which will identify the final dimensions of the corrective actions, marker layer layout, thickness, and makeup of the final cover layers within each DU.

6.14.3 Zone 3 Interim Measures and Long-Term Barriers

Zone 3 was sampled in 2018 and several Zone 3 DUs were sampled in triplicate in 2019. As described in Section 6.7, analysis of samples from DUs 1G, 1Q, 1U1, 1U2, and 5KK for dioxins and furans TEQ yielded results ranging from 4,510 – 14,100 ppt. Additionally, DUs 5EE and 5HH1 yielded arsenic concentrations greater than the non-residential DCC. The UCL evaluation presented in Section 6.12.3 indicates DUs 1DD, 1J1, 1P2, 1T1, 1Z, 2C2, 5C2, 5F2, 5HH1, and 5MM also have dioxins and furans TEQ results greater than the non-residential DCC. Furthermore, as the initial focus of implementing IMs in Zone 3 in 2018 and 2019 were on DUs with dioxins and furans concentrations greater than 4,500 ppt, seven additional DUs will need IMs implemented in 2020: 1O1, 1D2, 1H, 1T2, 2C1, and 2C3. The DUs requiring fencing or long-term barriers are shown in Figures 6-53 and 6-54 (note Figure 6-54 only depicts two of the DUs discussed in this section, 1P2 and 1DD). The status of these DUs is summarized on Table 6-37.

Work Completed in 2018

Access was restricted to DUs 1G, 1Q, and 5KK by placing fencing and signage. In cases where continued access to the areas is necessary, such as 1U1 and 1U2, the proper use and disposal of PPE to mitigate exposure via ingestion for workers who must enter and work in the area was also discussed. These actions were completed in October 2018.

Construction drawings were assembled to show the planned removal of the top six inches of gravel/soil at DUs 1U1 and 1U2 and were supplied to EGLE in December 21, 2018 and the drawings were accepted by EGLE in the first quarter of 2019.

Work Completed in 2019

The installation of the long-term barrier at DUs 1U1 and 1U2 started in late July 2019 and consisted of the removal of six inches of gravel/soil followed by the laying of a non-woven geotextile visible marker layer to be covered by six inches of clean gravel cover. The construction-focused soil management plan and dust-track out control plan submitted and approved in September 2018 was implemented during this work. The construction of the long-term barrier was completed in late August 2019. A set of as-built drawings will be provided to EGLE upon completion, which will identify the final dimensions of the corrective actions, marker layer layout, thickness, and makeup of the final cover layers within each DU.

DU 1G was partially paved over in 2019 as a part of a construction project of a new warehouse on site. However, the remaining unpaved portion of the DU remains barricaded with fencing and signage.

Additional sampling was completed at several Zone 3 DUs in the fall of 2019 to help in the potential design of a long-term barrier. However, the full evaluation of these results will not be available for this CAIP submittal. These results, along with any additional proposed interim measures or long-term barriers (if necessary) will be shared during one of the monthly Corrective Action meetings with EGLE and Dow and will also be summarized in the 2020 CAIP. The following summarizes the Zone 3 DUs sampled in the fall of 2019:

- DUs 1Q and 1O1 were subdivided (Figure 6-55) to better assess the delineation of elevated dioxins and furans impacts observed in the 2018 results of 1Q (dioxins and furans TEQ of 14,100 ppt). As noted previously, DU 1Q has been fenced since October 2018. DU 1O1 was divided into three DUs, 1O1A, 1O1B, and 1O1C and DU 1Q was broken up into two DUs to properly

assess the area per the Direct Contact CSM for the Midland Facility. Each of these DUs were sampled in triplicate in for dioxins and furans.

- DU 5KK, which was fenced off with signage in October 2018, was also sub divided into two separate DUs, 5KK_N and 5KK_S, as both were stormwater basin features that are physically separated by 49 Building (Figures 6-45 and 6-46). This DU was split to confirm whether only one of these features or both features needed a long-term barrier. Each of these new DUs were sampled in triplicate for dioxins and furans.
- DU 5C2 was sampled in triplicate for dioxins and furans analysis during the summer 2019 sampling event. When the Midland FAST result for the duplicate sample was received (169,000 ppt), fencing and signage was immediately installed as an interim measure. The DU was subdivided into smaller decision units (Figure 6-44) and sampled in the fall of 2019 to determine if a particular portion of the DU contributed to the exceedance. These subdivisions were sampled in triplicate for the Category 1 TAL.
- DUs 5EE and 5HH1 were sampled in triplicate to determine whether the arsenic exceedances observed in 2018 were truly above the non-residential DCC due to the replicate analysis discussion in Section 6.11. These areas are presently not fenced with signage but fencing and signage will be installed per the schedule presented in Section 17.0.

Work to Be Completed in 2020

For the remaining unpaved portion of DU 1G, construction drawings will be supplied to EGLE for review and the construction of the long-term barrier will be completed (pending EGLE acceptance/approval) per the schedule present in Section 17.0. For the remaining unpaved portion of DU 1G that is a stormwater swale, the long-term barrier will consist of a compactable soil fill that can accommodate sod growth which will be placed over a geotextile marker layer in lieu of placing six inches of clean compacted gravel over the geotextile marker layer. Additionally, the sides of the swale will be seeded/blanketed. The remaining unpaved portion of DU 1G that is not a stormwater swale will have clean compacted gravel placed over a geotextile layer after 6" of soil is removed. A set of as-built drawings will also be provided to EGLE upon completion which will identify the final dimensions of the corrective actions, marker layer layout, thickness, and makeup of the final cover layers within each DU.

DUs 1D2, 1DD, 1H, 1J1, 1P2, 1T1, 1T2, 1Z, 2C1, 2C2, 2C3, 5EE, 5F2, 5HH1, and 5MM will require fencing as an IM. These DUs require fencing because the UCL evaluation completed in 2019 has indicated they need an interim measure. Fencing and signage will be installed in accordance with the milestone schedule provide in Section 17.0. Results and hazard information will be provided to the workers in nearby areas. In cases where access to these areas is necessary, additional PPE for workers who must enter and work in the area and the means for proper disposal of PPE will be communicated and implemented.

6.14.4 Zone 4 and Stormwater Basin CSM Interim Measures

Most of the results from Zone 4 were less the non-residential DCC. There were four DUs with dioxins and furans TEQ results greater than the non-residential DCC (Figures 6-35 and 6-56): Z4-1-3 (1,840 ppt), Z4-1-11 (1,110 ppt), Z4-2-76 (3,750 ppt), and Z4-2-77 (1,710 ppt). Two DUs identified in the Category 5 Stormwater Basin CSM evaluation (Figure 6-48) exceeded the non-residential DCC: SW-5J (1,510 ppt) and SW-5W (2,480 ppt). The status of these areas is summarized on Table 6-37.

These areas will be fenced with signage. The fencing and signage will be installed in accordance with the milestone schedule provided in Section 17.0. Results and hazard information will be provided to the workers in nearby areas. In cases where access to these areas is necessary, additional PPE for workers who must enter and work in the area and the means for proper disposal of PPE will be communicated and implemented.

DUs Z4-1-11, Z-2-77, and SW-5J will also be sampled in triplicate in 2020 to determine if these areas truly have dioxins and furans TEQ results greater than non-residential DCC. The UCL determined from these replicate samples will determine the path forward with regards to no further action or the continued implementation of the interim measure to be put in place. .

6.15 Year 5 Direct Contact Goals

Figure 6-57 presents the location of Zone 5 within the facility. Zone 5 covers approximately 53 acres within the facility complex. As nearly all of Zone 5 is in the Tittabawassee River 8-Year floodplain the protocols and procedures approved in the Tittabawassee River Floodplain: General Design and Implementation Workplan (Rev 1) (June 2015) (Tittabawassee Workplan). This methodology is summarized in Section 6.15.1.

Also, additional confirmation sampling will be completed as described in Section 6.15.2 to support the CSM developed for the Midland facility.

6.15.1 Zone 5 Tittabawassee River Floodplain Area Conceptual Site Model and Sampling Methodology

6.15.1.1 Tittabawassee River Flood Plain Conceptual Site Model

The portion of the Tittabawassee River floodplain that is generally flooded at least once every eight years (the “8-year floodplain”) is used to define the area of floodplain to be sampled. The primary constituents of interest (PCOIs) in the floodplain are dioxins and furans. Detailed reports of the floodplain studies and findings can be found in the Tittabawassee River Floodplain Response Proposal, dated May 30, 2014 (Dow 2014) and the 2006-2008 Site Characterization Study (ATS 2009).

6.15.1.2 Tittabawassee River Flood Plain Sampling Methodology

The 8-year floodplain will be split into DUs no larger than 20 acres. The DUs will extend from the 8-year floodplain boundary to the low river water line in cases where the parcel is immediately adjacent to the river, or to the property boundary closest to the river. Typically, if a property is split into multiple DUs the split will be perpendicular to the river.

The increment collection locations within each DU are generated using a systematic random approach. In the systematic random pattern, a random starting point is generated, and then subsequent increment locations are established on an even spacing within the remainder of the DU. The number of increments will vary based on the size and anticipated variability across the parcel, but is expected to generally consist of the following:

- Other land use DUs 10 acres or smaller: 60 increments
- Other land use DUs larger than 10 acres: 90 increments

The following subsections outline the processes used by the River team for sampling the floodplain. The sampling methodology for the floodplain has three major components: the field implementation, the sample processing, and the laboratory analysis. A brief summary of how this data will be evaluated is also provided.

Field Implementation

The increment collection locations are created in a Geographic Information System (GIS) in advance of the sampling activity. The planned sampling locations for a DU are loaded into handheld global positioning system (GPS) units for use by field teams to identify sampling locations. In heavily wooded

areas where tree cover precludes the use of a GPS unit, alternative techniques may be employed to ensure that the increment can be collected close to the planned location. In the field, each increment collection location will be clearly identified by a member of the field team with a survey flag prior to the sample collection. After a soil core has been collected at a location, the survey flag will be removed and documented to help verify all planned increments have been collected. At each DU, actual conditions may differ from those understood during sample plan generation. The field team will make best efforts to sample at the planned locations, but will use the following guidelines in the field to adjust increment locations on an as-needed basis:

- Increment locations will be selected no closer than twelve inches (12") from existing roads.
- If an incremental sample is identified at a location of a tree (including tree piles), it will be moved to the closest possible location where a sample can be obtained.
- If a biological hazard exists at the location of the incremental sample, the sample location will be adjusted to the closest possible location where it can be safely obtained
- . Soil samples will not be collected from areas typically covered with standing water such as a pond.

In addition, the initial grid of sampling points laid out in GIS may be altered as necessary to ensure adequate coverage of the geomorphic units that form the DU. This alteration may simply mean moving the entire grid by a set amount, or where adequate coverage (i.e. a proportional number of samples) still cannot be obtained across the geomorphic units within a DU, specific sample locations may be moved. Sample layouts will be reviewed with the Agencies prior to sampling.

Soil cores (increments) will be collected using stainless steel push samplers that facilitate consistent collection to the same depth and volume. Each increment will be collected from 0.5- to 1-inch diameter cores to a depth of 6 inches below ground surface (excluding any surficial vegetation layers, which will be cleared prior to core collection). The individual increments will be combined into a single composite sample in the field. Consistent with ITRC guidance, no decontamination is proposed between increment coring, however a decontaminated coring device will be used for each DU.

Sample Processing

After field collection, increment composite samples will be brought back to a clean designated workspace for processing, as described below, prior to delivery to the laboratory. Processing will generally follow methodology and best management practices as outlined in the ITRC incremental composite sampling guidance. Samples will be allowed to air dry, after which, they will go through a sieving process. Any remaining vegetation in the sample (generally assumed to be grass and roots) typically does not pass through the sieve and therefore is not part of the subsample extracted for analysis.

Following initial sieving, each composite sample will be homogenized. This homogenization process will be conducted using 1-5 gallon dedicated sealable cans and a motorized roller machine. The can will be left on the roller machine for a minimum of one hour to allow sufficient mixing/homogenization.

Following homogenization, a relatively thin layer of sample will be spread out horizontally in a square or rectangular layer. Scoops of sample will be made at regular intervals (similar to the incremental sample location design for each site) until the desired extraction size of 250 grams is obtained. Replicate composites will be made by taking scoops of sample at regular intervals directly adjacent to the first scoop. Remaining volume after building the composite may be retained as necessary.

Laboratory Methodology

Once the samples are processed, all samples will be packed for delivery to the Dow laboratory. Processed samples will be placed in jars with appropriate labelling and delivered to the laboratory for login and processing. A method has been developed by Dow analytical chemists by adaptation of existing USEPA Method 8280 for rapid determination of polychlorinated dibenzo-p-dioxins (PCDDs) and dibenzofurans (PCDFs) in soil by high resolution gas chromatography/high or low resolution mass spectrometry (HRGC/HRMS or RGC/LRMS). This method was developed to decrease the time necessary for each laboratory analysis. The Standard Operating Procedure (SOP) for Method 8280 was submitted to EGLE on July 5, 2006 as part of the QAPP for the Geomorph Investigation (ATS 2006), which was approved by EGLE (following consultation with USEPA) later that year. The rapid method is also outlined in the 2010 Site QAPP (ATS 2010). The rapid method extracts and analyzes the entire 250-gram sample. The rapid method is anticipated to be used for the majority of sample analyses; however, Dow reserves the right to use the standard method on a property by property basis and will consult with the Agencies when the standard method is used.

Data Evaluation

Basic summary statistics will be prepared for the soil results from these DUs similar to those completed for Zones 1 through 4. These tables include common statistical parameters such as mean, standard deviation, minimum and maximum detected values, and minimum and maximum reporting limits (RLs) of non-detects (NDs). The number of samples and detection rates are also included to provide information regarding sample size and detection frequency. Additionally, these summary statistic tables present the results of the screening comparison to relevant criteria.

A screening-level evaluation of the data is performed by comparing each data point to non-residential DC criteria (DCC) for soil. EGLE Part 201 December 30, 2013 non-residential DCC for soil are selected whenever available (EGLE, 2013). EPA Regional Screening Levels (RSLs) for industrial soil are selected whenever EGLE screening criteria are not available (document release date: May 2016) (EPA, 2016).

6.15.2 Additional Dioxins and Furans Sampling in Zones 1 through 4

As areas originally hypothesized likely to not have results above the non-residential DCC in the CSM for the Midland Facility have unexpectedly had exceedances (see discussion regarding stormwater basins in Section 6.13), several DUs will be revisited in 2020 for dioxin and furan sampling:

- Category 3 and 4 DUs in Zones 1 through 3 will be revisited to be sampled for dioxins and furans in 2020 (Figures 6-7, 6-8, and 6-58). Note that several Category 4 DUs (particularly in Zones 1 and 2) have since been recategorized and resampled either as a Category 1 DU in 2018 or a Category 5 DU in 2019.
- Approximately 10% of Category 6 DUs sampled to date that have not been sampled in triplicate will be resampled in triplicate to fully assess the presence of dioxins and furans in soil with regards to the direct contact pathway at the Midland facility. This is being done to confirm that the Category 6 areas have results less than the non-residential DCC and that the conceptual model for these areas has proven to be accurate. The figures to be sampled are shown on Figure 6-59.

Dioxin and furan confirmation sampling will also take place on the one Zone 2 DU sampled in 2019 (1-46) seven Zone 4 DUs and two Category 5 Stormwater Basin CSM Evaluation DUs. These DUs are shown in Figures 6-60. This confirmation sampling is being done as the dioxins and furans TEQ results for these DUs either only slightly exceeded the non-residential DCC or fall within the 550-990 ppt concentration range discussed in Sections 6.8 and 6.11. The results of this sampling will help clearly define the path forward for these DUs in terms of whether no further action is truly warranted, or interim measures need to be taken.

7.0 ON-SITE OUTDOOR AIR PATHWAY

This section presents an evaluation of the soil volatilization to ambient air and particulate soil inhalation pathways using the data collected to support the DC pathway evaluation.

7.1 Soil Volatilization to Ambient Air

The soil volatilization to ambient air exposure pathway applies to all land uses where hazardous substance vapors may emit from soils to ambient air. The outdoor air at the facility is monitored by the Ambient Air Monitoring Program (Attachment 16 of the License). Dow will continue to monitor and review ambient air as part of future corrective action efforts (Appendix G of Attachment 19 of the License).

Construction workers can potentially encounter vapors when working with subsurface soils or in a trench scenario; however, exposure is not reasonably expected to be significant since the exposure routes are managed by air monitoring, elimination of pathways, engineering controls and PPE specified in the Worker Exposure Control Plan, Appendix C of Attachment 19 of the License.

To evaluate this exposure pathway, results from the DC sampling for each zone were compared to the December 30, 2013 Part 201 Non-Residential Infinite Source Volatile Soil Inhalation Criteria (VSIC). The results of the screening comparison are discussed by zone below.

Zone 4

Zone 4 represents approximately 424 acres that were evaluated by soil sampling in 2019. Zone 4 encompasses the area west of the Tittabawassee River. The following land use categories were sampled in Zone 4:

- Category 1, Laydown Areas – 40 DUs for Aerial Dispersion and Other Sources target analyte lists (TALs);
- Category 2, Historic Grass Areas – 97 DUs for Aerial Dispersion TAL;
- Category 5, Stormwater Basins – 8 DUs for Imported Soils, Aerial Dispersion via Run-off TALs; and
- Category 6, Vegetated Cap Closed by Dow – 24 DUs for Aerial Dispersion, Leachate Breakout, and Imported Soil TALs.

In addition to Zone 4 DC sampling, confirmation sampling was performed in 25 stormwater basins across the site. These results were also included in this evaluation. Summary statistics and screening comparisons of results to the Part 201 non-residential infinite source VSIC are presented on the following tables:

- Table 7-1 presents the Zone 4 Category 1 results; and
- Table 7-2 presents the Zone 4 Categories 2, 4, 5 and 6 results; and
- Table 7-3 presents the 2019 Stormwater Basin Confirmation Sampling results.

Based on a comparison to the MDEQ 2013 non-residential infinite source VSIC, all results were less than criteria; therefore, no further evaluation is proposed at this time in Zone 4 for the soil volatilization to ambient air exposure pathway.

7.2 Particulate Soil Inhalation

The particulate soil inhalation exposure pathway addresses the emission and dispersion of contaminated soil particles into the ambient air (inhalation of fugitive dust particles). Exhaust constituents from process vents, power generation, and thermal incineration processes may have deposited onto plant soils. During dry periods, these soils may have been disturbed by equipment or vehicles and blown by the wind, resulting in fugitive dust emissions.

Fugitive dust control has been in progress at the Midland Plant since 1986. Dow is currently required by the 2015 Operating License and its Renewable Operating Permit (Section 1, IX.5) to provide and regularly update an operating program to control fugitive dust sources or emissions. The current fugitive dust control program requires semi-annual review and updates. In addition, fugitive dust emissions from the facility are monitored for dioxin emissions on an ongoing basis along the plant perimeter pursuant to the "Soil Box Data Evaluation Plan," approved by MDEQ on September 25, 2015. Monitoring began in 2002 and continues to show the fugitive dust control program for the facility is effective.

In order to limit the generation of fugitive dust and particulates, Dow has placed surface cover on surface soil in certain areas of the facility. The covers include clean top soil and vegetation, gravel, and/or asphalt. Existing covers are managed and maintained. Based on current conditions, this pathway is likely to be adequately controlled.

To evaluate this exposure pathway, non-dioxin and 2,3,7,8- tetrachlorodibenzo-p-dioxin (TCDD) results from the DC sampling for each zone were compared to the December 30, 2013 Part 201 Non-Residential Particulate Soil Inhalation Criteria. The non-dioxin summary statistics and screening comparison are presented on the following tables:

- Table 7-1 presents the Zone 4 Category 1 results;
- Table 7-2 presents the Zone 4 Categories 2, 4, 5 and 6 results; and
- Table 7-3 presents the 2019 Stormwater Basin Confirmation Sampling results.

Note that roughly 10% (14) of the 2018 Zone 3 DUs were resampled in triplicate in 2019 for dioxin/furan analysis via 1613b to confirm their 2018 FAST results that were near the non-residential DCC of 990 parts per thousand ppt. Additionally, 10 Zone 4 Category 1 DUs and seven Zone 4 Category 6 DUs have six 2,3,7,8-TCDD results as these DUs were collected in triplicate using the older increment density and also in triplicate using the newer increment density (which is discussed in greater detail in Section 6.0). These results are included in this evaluation. The 2,3,7,8-TCDD summary statistics and screening comparisons are presented on the following tables:

- Table 7-4 presents the Zone 4 Category 1 results;
- Table 7-5 presents the Zone 4 Categories 2, 4, 5 and 6 results; and
- Table 7-6 presents the 2019 Stormwater Basin CSM and Zone 3 Confirmation Sampling results.

As shown in the tables listed above, all results for non-dioxins and 2,3,7,8-TCDD are below the non-residential particulate soil inhalation criteria. Therefore, no further evaluation is proposed at this time in Zone 4 to address the particulate soil inhalation exposure pathway.

7.3 Conclusions and Recommendations

A comparison to MDEQ 2013 Part 201 non-residential Infinite Source VSIC and Particulate Soil Inhalation criteria demonstrated that no further evaluation is warranted at this time for Zone 4. Dow will perform this

evaluation on Zone 5 data to be collected in 2020 and confirmation data collected from Zones 1 through 4 in 2019 and 2020 in the *2020 Annual Corrective Action Implementation Summary Report and 2021 Work Plan (2020 CAIP)*. In addition, Dow will maintain current ambient air and fugitive dust monitoring programs until further evaluation is completed and it is determined that further action is warranted.

8.0 SLUDGE DEWATERING FACILITY

The Sludge Dewatering Facility (SDF) is a closed land-based disposal located on the corner of Saginaw Road and Salzburg Road in Midland County. It was used in the 1970s and 1980s for dewatering and disposal of wastewater treatment sludge generated at Dow's Midland Plant site. The unit is currently maintained under the Post-Closure Plan (modified 2015) and routine sampling is currently conducted in accordance with Condition II.K. and IX.A.1. of the Operating License.

8.1 Overview of Site Characterization and Interim Measures

As detailed in the Environmental Monitoring Program Sampling and Analysis Plan (SAP) for the Operating License, samples and field parameters are obtained from the SDF groundwater detection monitoring wells on a quarterly basis. Samples and field parameters are obtained from perimeter wells every four years, or in response to hydraulic monitoring performance criteria not being met. Static water levels (SWLs) are collected from SDF wells on a quarterly basis.

The *2015 Operation and Maintenance Inspection Report for the Sludge Dewatering Facility (SDF)* (Inspection Report) conducted by the MDEQ noted an outward gradient identified at Cell 1. This report also noted that water levels in the internal piezometer (6143) within Cell 1 and external well 3775 appeared to be tracking (Figure 8-1). As an immediate action in response to the noted outward gradient in Cell 1, perimeter monitoring well 3916 was added to 2016 quarterly sampling events and will continue as such until determined otherwise.

In further response to the conditions of concern noted in the MDEQ Inspection Report, Dow also submitted a *Response to 2015 Operation and Maintenance Inspection Report*, dated November 19, 2015. As described in this document, the water levels measured at 3916 have been measured below that of internal piezometer 6143 consistently in recent years. A decrease in groundwater elevation in well 3916 was observed in 2012, around the time of road construction on Salzburg Road, which included changes to the ditch along the south of Salzburg Road. Evaluation of the SWL data has continued to indicate an inward gradient at all other SDF wells. The additional chemical analyses conducted for perimeter well 3916 has also provided no indication of a release from SDF despite the noted apparent outward gradient.

The *Response to 2015 Operation and Maintenance Inspection Report* also detailed analyses of hydraulic groundwater data and describes that additional investigation would be taken to resolve any potential issues. The additional investigation was then described in the *2016 Corrective Action Implementation Work Plan* (2016 Work Plan) for the Midland Plant Facility. The 2016 Work Plan described planned slug and pump tests that were anticipated and that the preliminary findings of the slug test would be used to modify and complete the design of the investigation.

As a result of the analysis of the slug test data, the pump test conceptual design presented in the 2016 Work Plan was modified and Geoprobe Direct Image Hydraulic Profiling Tool (HPT) work was added to the investigation to better address the existing conditions and provide the data necessary to make further conclusions. In May 2016, Dow submitted an Activity Plan to Department of Environmental Quality (DEQ) detailing single well pump tests, HPT work, and the installation of an additional groundwater monitoring well that were to be completed through the investigation to better characterize the waste material and the surrounding hydrogeologic environment. Dow requested DEQ approval of the Activity Plan specifically due to the need to disturb the final cover to complete the HPT borings at the closed facility. On July 8, 2016, the DEQ granted conditional approval of the Activity Plan.

Dow then initiated a drilling and HPT investigation at Cell 1 and Cell 7 on July 12, 2016. HPT borings were conducted along the north and west perimeter of Cell 1 (SDF-1 through SDF-7; and SDF-15 through 19). An additional two locations were pushed within the central area of Cell 1 (SDF-8 and SDF-9), including one adjacent to the existing internal piezometer (6143). Another three locations were advanced outside Cell 1 along the northeastern perimeter (SDF-11, SDF-12, and SDF-13) and one other near the center of Cell 7 (SDF-10) (Figure 8-2). Fisher Contracting cut the existing 30-milliliter (mL) high-density

polyethylene (HDPE) liner to facilitate the borings. NAL Services, Inc. completed the repairs to the liner by extrusion welding the full perimeter of an HDPE patch to the existing liner at each boring location, and each weld was vacuum box tested and visually inspected. The repairs were certified by a Registered Professional Engineer in the State of Michigan and the certification was submitted to the MDEQ in October 2016.

Two-single well constant rate-pump tests were completed at Cell 1 and Cell 7 in September 2016. Evaluation of the pump test results was completed in 2017. The pump tests were conducted at existing internal piezometers located inside both cells.

8.1.1 CSM Development & Groundwater Modeling/Pilot Study 2018

Based on the data evaluations performed in 2017, the planned priority actions for SDF during 2018 included the installation of an approximately 100-ft long section of permeable backfill and perforated collection tile that would be tied into the existing manhole (MH) within Cell 1. The demonstration-scale system was intended to be monitored for drawdown and will then be used to design a full-scale implementation for Cell 1 to reduce the head inside the cell to an elevation below that of the external piezometers.

A CSM of the SDF including Cell 1 was completed in 2018 (Figure 8-3). Site characteristics were entered into a 3D-groundwater flow modeling program (MODFLOW) and capture zone and radius of influence (ROI) simulations performed to demonstrate the effectiveness of the proposed pilot system (Figure 8-4). The model was constructed using observed groundwater heads and gradients collected from 16-existing monitoring wells, current drain flow rates, measured hydraulic boundary conditions or River Stage Elevations (United States Geological Survey [USGS] 04156000 Tittabawassee River at Midland, MI) and infiltration rainfall rates (Climatological Data for Midland, MI) across the site domain.

The model was *quantitatively* calibrated using the existing head levels. The residual errors (observed head minus modeled or simulated head) were calculated in the model, calibration was achieved once a predetermined statistical level of accuracy was met, i.e., absolute residual mean (ARM) less than 1.0 ft and normalized root mean square (NRMS) of less than 10%. *Qualitative* methods of calibration included a comparison of statistically generated observed head contours vs modeled contour levels and gradients. An additional spreadsheet water balance model showing total water in and total water out (Figure 8-5) was also completed and compared to the net loss simulated in the groundwater model. The model demonstrated that the pilot project at Cell 1 should produce the desired result by generating the required drawdown and controlling the gradient (Figure 8-6).

Because the demonstration scale dewatering system within Cell 1 would necessarily disturb the final cover at the closed SDF in Cell 1, Dow submitted a request to the MDEQ to review a liner repair plan to facilitate installation of the demonstration scale dewatering system for Cell 1 at the SDF on December 19, 2017. DEQ staff provided comments on February 28, 2018, and the plans were discussed during a meeting in Lansing on March 1, 2018. Additional information was then prepared and submitted in a correspondence dated July 13, 2018.

The pilot tile installation and liner repair were completed in late October 2018 with a plan for monitoring well installation in early 2019.

8.2 Work in 2019

Work in 2019 focused on the data collection and assessment of the installed pilot system.

Evaluation of the SDF groundwater monitoring network at the SDF Cell 1 was performed to study the groundwater flow direction, well construction, and current and proposed monitoring well placement relative to groundwater flow direction with the current pilot system. Installation of eight-9000 series monitoring wells were installed in the SDF Cell 1 to assist in the pilot drain evaluation (Figure 8-6).

The 9000-series well installation started in late 2018 (December 12, 2018) and was completed on January 11, 2019. Water elevation monitoring of the 9000 series wells was initiated on January 11, 2019 using In Situ® Level Troll 700 pressure transducers. Water level monitoring of the pilot system was completed July 1, 2019. The completed pilot study evaluation included water levels collected from transducers installed in the new 9000-series wells, manual (quarterly) recorded fluid levels at existing perimeter monitoring wells 3775, 3916 and internal Cell 1 piezometer 6143.

Stage elevation at USGS Station #04156000 Tittabawassee River at Midland, Michigan along with daily infiltration rates were compiled from the start of the pilot system (Figure 8-7). River stage crested above flood stage on March 16, 2019 (National Oceanic & Atmospheric Administration (NOAA) Tittabawassee River at Midland (MIDM4). Transducer data (i.e., 9497) confirmed a transient seasonal flow system with overall downward trending fluid levels until early March's seasonal rebound (Figure 8-8).

Additional pilot system evaluation results indicated the following:

- The pilot system was installed and functioning in October 2018, while the installation of the monitoring wells and start of transducer monitoring were not completed until early January. This resulted in an early lag-time in data collection and inconclusive early-time drawdown data with the transducers.
- Evaluation of data concluded that hydraulic head was already below pre-pilot static head at the start of the transducers; however, real-time manual measurements confirmed drawdown in Cell 1 monitoring wells and an inward hydraulic gradient toward the pilot drain (Figure 8-9 and 8-10).
- The pilot drain created a consistent inward gradient of approximately 0.025 feet per foot (ft/ft) and ROI of over 100 ft from start of monitoring (1/2019) until monitoring end (7/1/2019).

Overall the pilot system demonstration-scaled system showed the drain was effective and did produce the desired result; however, may be more susceptible to seasonal groundwater variation than anticipated. As such, final steady state groundwater modeling studies utilizing fully penetrating barrier walls (slurry walls) and a new drain system were modeled to assess potential increased drawdown and capture in Cell 1 (Figure 8-11). Therefore, the anticipated solution to improve groundwater migration and gradient control at the SDF Cell 1 is a fully penetrating slurry wall along the North and West perimeter of Cell 1. Leachate collection and groundwater capture will be improved with the proposed installation of a new drain tile collection system encapsulating Cell 1. A conceptual drawing of this plan is included as Figure 8-12.

8.3 Path Forward

Work in 2020 will focus on the preparation of design plans for the slurry wall/drain tile conceptual upgrade for Cell 1, and the design of appropriate means to adequately monitor the effectiveness of the design.

This includes a further investigation and assessment of the groundwater elevation changes observed in well 3916 and assessment of the appropriateness of the groundwater monitoring location. A decrease in groundwater elevation in well 3916 was observed in 2012, around the time of road construction on Salzburg Road, which included changes to the ditch along the south of Salzburg Road. It is hypothesized that changes to the ditch may have impacted local groundwater flow at this location. Preliminary modeling of the groundwater elevation at both 3916 and 3775 have demonstrated a statistically significant decreasing trend at 3916, while no such trend at 3775 (Figures 8-13 and 8-14). Further investigation of 3916 may include additional evaluation of existing data or may warrant the installation of a supplementary monitoring well(s) and data collection to gather additional information and/or establish an alternative groundwater sampling location.

Construction design plans for Cell 1 will be prepared and submitted for agency review and approval. It is anticipated that construction will take place at the beginning of the 2021 construction season.

Work in 2020 is anticipated to be completed in accordance with the milestone schedule presented in Section 17.0. Unless otherwise necessary or requested, plans or findings will be provided during periodic progress meetings, which are scheduled to occur on an approximately monthly basis. Annual updates detailing the work completed and projected for the next year will be presented in the annual CAIP.

9.0 POSEYVILLE LANDFILL

PLF is within the contiguous property boundary of Dow, located west of the Dow industrial complex and southwest of the City of Midland in Midland Township (Figure 9-1). The landfill is bordered on the east by the Dow complex, and by Dow property to the north. The landfill was operated as a municipal landfill by the City of Midland, beginning in 1940. Dow purchased the landfill and began operations in 1955. Landfill operations were discontinued on January 5, 1981 (The Dow Chemical Company, 1989).

A draft compliance and final closure schedule for PLF, was submitted to Michigan Department of Natural Resources (**MDNR**) by Dow on August 18, 1981. The proposed schedule for closure included details regarding the installation of additional monitoring wells to be sampled and analyzed for specific parameters. Dow also committed to defining the hydrogeological conditions in the northeast corner of the site including the flow direction, aquifer thickness, and water quality. In addition, Dow committed to further defining the flow direction in the upper aquifer in the southeast corner of the site, which included a groundwater contour map for the eastern portion of the landfill.

9.1 Overview of Site Characterization and Interim Measures

Dow was issued a hazardous and solid waste amendment (HSWA) permit on October 12, 1988 and has since been involved in the required submittal of corrective action requirements including closure packages and Corrective Action Monitoring Plans for the solid waste management units (SWMUs). Dow was required to submit a RCRA Facility Investigation (RFI) Phase I Environmental Monitoring Report (Phase I) for the PLF SWMU within 365 days of the effective date of the permit. This report was submitted October 12, 1989 and details past monitoring requirements, an apparent leakage in the northeast corner of the facility, and corrective action measures taken.

In 1996, Dow submitted the final two sections of the PLF RFI Phase II Release Assessment (Phase II). The report focused on chemical and hydraulic monitoring data of the isolated plume on the northeast corner of the facility, and analysis of the chemical data from groundwater within the plume to evaluate the possibility of a continuing release from the landfill. The data was evaluated in order to provide a comprehensive hydraulic picture of the effectiveness of the purge wells employed to contain and remediate the groundwater in the plume.

Routine sampling at PLF is currently conducted in accordance with the Operating License SAP. Hydraulic information, as well as groundwater and leachate samples are collected and analyzed. Samples are regularly collected for Leak Detection Chemical Monitoring, Corrective Action Chemical Monitoring, and Corrective Action Hydraulic Monitoring. Four purge wells in the northeast corner of the landfill (2690A, 2917, 2960, and 2961), that were installed to mitigate the plume in the northeast corner, are part of the Corrective Action Chemical Monitoring program, and are sampled quarterly for benzene, chlorobenzene, chloroform, and ethylbenzene.

The four purge wells are screened at the base of the Eastern Till Sand Body, which lies beneath the northeast corner of the PLF and extends beyond the landfill boundaries (Figure 9-2). A slurry wall, keyed into clay till beneath the Till Sand, is present to isolate that portion of the Till Sand present beneath the landfill. The well pumps are controlled by water level probes in the well casings in order to maintain a consistent drawdown profile into the well. The volume of water pumped from each of the four purge wells is recorded.

Hydraulic monitoring is conducted for the Eastern Till Sand outside of the landfill perimeter slurry wall using an array of piezometers as shown in Figure 9-1. The hydraulic monitoring is utilized to observe groundwater drawdown into the four purge wells and ensure that existing contaminants do not migrate away from the landfill perimeter.

9.2 Northeast Corner

In 2016, Dow contracted with EarthCon Consultants, Inc. (EarthCon) to perform groundwater plume analytical services to further assess the groundwater plume in the northeast corner of the PLF. EarthCon initially performed the plume analytics to help provide a better understanding of the overall behavior of the plume dynamics by conducting a stability analysis looking at the center of the mass over time, the areal extent of the plume, and the overall spatial difference of the plume from 1995 to August 2016.

EarthCon found that in the earlier period of the analysis, the dissolved plume in the northeast corner was centered near well 2917 and extended to the east near purge well 2961 and west near purge well 2960. Sustained pumping from peripheral purge wells 2960 and 2961 appears to have resulted in cleanup of the dissolved plume in the eastern and western portions by about 2010 and until the end of the period of their initial period of analysis (Figure 9-3). Also, during this period, the dissolved plume exhibited patterns of continued attenuation in the eastern portions of the plume area, including the vicinity of 2917.

The evaluation also demonstrated that:

1. The release of constituents was likely not a one-time release. It appeared from the analyses that there may be an on-going sourcing of constituents into the study area. However, with the recent pumping regime at the site and the recent site data, it also appeared that the plume was at or near a point of hydrodynamic equilibrium (e.g., the rate of pumping is such that the plume is stable).
2. The data analyses suggested that there is an apparent dynamic between purge wells 2690A and 2917, whereby the plume behaves differently depending on the ratio of flow rates between these two wells. For example, based on observation of site data from 1995 through 2016, plume attenuation rates were better when the flow rate from 2960A far exceeded the flow rate from 2917 and were sub-optimal when flow rates from 2917 exceeded those from 2690A.
3. Purge wells 2960 and 2691 have exhibited generally ND or below maximum contaminant level (MCL) concentrations. Their continued pumping appears to be serving to expand (or retard the collapse of) the present dissolved plume.

Based on this evaluation and other analyses conducted in 2016, additional actions were planned for 2017 including the development of a Pilot Purge Well Optimization Study. Since purge wells 2960 and 2961 exhibited generally ND or below MCL concentrations, and their continued pumping could be serving to slow the collapse of the present dissolved plume, the pilot optimization study was developed to include an initial intended trial period of one to two years, depending on observable trends, during which wells 2960 and 2961 would be shut down and pump rates of the remaining two purge wells would be optimized. As the 2016 evaluations also suggested the continued release of COCs in the northeast corner of the landfill, additional investigation of the potential continued sourcing of the plume area was also planned.

As reported in the 2017/2018 CAIP, a total of 27 borings were advanced throughout the northeast corner of the PLF during the 2017 membrane hydraulic profiling tool (MiHPT) Investigation. The MiHPT investigation was also supplemented through the collection of groundwater samples at existing piezometers, monitoring wells, and purge wells as well as grab water samples collected at MiHPT locations to assist in the interpretation of results and confirm specific analyte concentrations. Based upon the MiHPT boring responses and the confirmatory water quality data, the apparent breach in the slurry wall was identified between MiHPT boring locations PLF-14 and PLF-16, centered approximately on MiHPT boring PLF-15 (Figure 9-4). Impacts were observed to extend to the north of the slurry wall.

9.2.1 Purge Well Optimization Pilot

In March 2017, details of the Purge Well Optimization pilot study were shared with EGLE at the regular monthly coordination meeting. The implementation of the optimization study began November 13, 2017

by shutting off the pumps at 2960 and 2961. Purge wells 2690A and 2917 were inspected and refurbished in late 2017 so that flow rates for these two wells could be easily modified as needed throughout the pilot.

Throughout study the 2690A/2917 flow ratio is expected to be modified over time depending on plume behavior and resulting trends. It is the intent that the rate of 2917 be kept well below 2690A so as not to "pull" the plume from 2690A toward 2917. Optimal conditions in the past were observed when 2917 pumped much less than 2690A, approximately one fourth to one fifth of the 2690A flow rate; and were sub-optimal when flow rates from 2917 exceeded those from 2960A. The purge wells will continue to be monitored and sampled in accordance with the SAP throughout the pilot.

Although the purge wells were refurbished in late 2017 so that the desired flow rates could be achieved, attempts to modify the pump settings to achieve the desired rates throughout early 2018 were unsuccessful. Additionally, in Q1 2018, 2917 was pumping at a rate higher than 2690A. Due to the low pump rates and a reverse in the primary and secondary pump rates, the plume began to spread to the east and southeast.

During the Q1 2018 sampling event monitoring wells 5923, 5924, and 2549 were added to the optimization pilot monitoring well network in order to have a more robust network for monitoring plume migration. The rest of the monitoring network consists of the PLF Corrective Action Chemical Monitoring well network listed in Table 2-N of the Sampling and Analysis Plan for the Midland Plant.

By Q2 2018, the 2917 rate dropped below that of 2690A; however, it was still pumping at approximately 90% of the rate of 2690A. In the Q3 2018, the pump at 2917 failed and needed to be replaced. This quarter the pump rate of 2690A was significantly higher than that of 2917.

Due to the inadequate pump performance, the wells were re-inspected in June 2018. A downhole camera was utilized to inspect the screen and integrity of casing. The inspection found that both screens and casings appeared to be in good condition and the columns were clear; however, both wells showed considerable precipitation and/or microbial growth which appeared to be effectively clogging the both screens. As such, redevelopment was planned for both locations.

Wells 2690A and 2917 were redeveloped in late October through early November 2018. In the months following the redevelopment, pump rates increased substantially with the rate at 2690A increasing by 5.3 gallons per minute (gpm) and 2917 increasing approximately 0.9 gpm from pre-development setting (Table 9-1).

9.2.2 2019 Status of Purge Well Optimization Pilot

Tables 9-2 and 9-3 present the purge and flow rates for purge wells 2690A and 2917 for 2019 and the statistical trends of three primary plume characteristics (area, concentration, and mass) observed in 2019. The statistical trends presented in Table 9-3 and discussed below are all in relation to the March 2018 (Q1 2018) sampling event, which occurred near the beginning of the optimization pilot.

Figures 9-5 through 9-7 show the plume analysis for the three primary COCs for the plume (benzene, chlorobenzene, and ethylbenzene, respectively) as well as the average pumping rates for the purge wells 2690A and 2917 observed during the applicable quarter. Figure 9-8 shows groundwater elevation and flow maps Q1-Q3 as well as the average regional groundwater elevation for the study area from 2006 to present.

During Q1 2019, the wells were left to run at nearly the same (unadjusted) rates as the post-development rates observed in Q4 2018 to determine what impacts these rates had on the plume since Q4 2018 sampling event occurred too close to the redevelopment to observe any appreciable changes in the plume. The groundwater elevations and flow directions shown in Figure 9-8 indicate 2690A heavily influenced groundwater flow in the plume area post-redevelopment in Q1 2019. The plume analysis

completed using Q1 2019 analytical data showed no change/statistical trend in plume concentration or mass for benzene, chlorobenzene, and ethylbenzene. The plume area with respect to chlorobenzene and ethylbenzene also observed no trend/change but saw a very minor decreasing trend with respect to benzene. The conclusion of the analyses was that the pumping rates at the purge wells were likely too high (particularly at purge well 2690A) and impacted water was beginning to be pulled from the area near the compromised slurry wall. In response to this assessment the pumping rates were decreased in early Q2 2019 to roughly 5 gpm at 2690A and approximately 1 gpm at 2917 to mitigate these effects.

The plume analyses of Q2 2019 data showed a smaller plume area for benzene, chlorobenzene, and ethylbenzene, but statistically no trend was observed with regard to plume concentration for this same event. The plume mass with respect to benzene and ethylbenzene showed no trend/change, but a slight decreasing trend was observed for chlorobenzene. As a result, the pump rates implemented in Q2 were maintained for Q3 in order to observe more appreciable changes in the plume concentration and mass and a continuation of the decreasing trend for plume area. However, the groundwater elevation contouring and flow figure for May shown in Figure 9-8 shows the flow arrows along the eastern side of the pilot area starting to rotate to the east as opposed to going in the westerly direction observed in Q1.

Pump and flow meter issues at 2690A during the first three weeks in Q3 2019 compromised the ability to accurately record pump and flow rates during that time. A downhole camera was again utilized during this three-week period to inspect the screen and integrity of casing of each well to confirm well conditions were not contributing to any of the ongoing issues with the meters. The inspection found the screens and casings in good condition and the water columns were clear and neither well showed any appreciable precipitation and/or microbial growth. The Q3 plume analyses showed a decreasing trend in plume area for benzene, but no trend/change was observed with regards to a change in plume area for chlorobenzene and ethylbenzene in Q3 2019. The average concentration of the plume with respect to benzene and chlorobenzene showed no trend, but the average plume concentration of ethylbenzene showed an increasing trend. Additionally, the plume mass with respect to benzene saw a slight decreasing trend, but no trend was observed with respect to chlorobenzene and ethylbenzene. The groundwater elevation contouring and flow figure for May shown in Figure 9-8 shows the same eastward rotation of flow along the eastern side of the pilot area.

As discussed in Section 9.3, the slurry wall located along the northeast corner of PLF was replaced in 2019 with work starting in late September and ending in mid-October. The wells were turned off the morning of September 23, 2019 and remained off until the morning of October 18, 2019 as part of the slurry wall construction effort. The plume analyses for Q3 were conducted shortly before the completion of the slurry wall. It was determined that the pump rates of the purge wells should be maximized once the slurry wall construction was complete. The purge wells were turned back on the afternoon of October 18, 2019 and rates are continuing to be maximized to date.

9.3 Leachate Collection System and Slurry Wall Upgrades

During 2018, the planned upgrades for the south side of the tile from Lift Station #203 to MH203L began (Figure 9-9). Work started in October 2018 and by December 2018, 2,300 ft of tile and manholes along the southern perimeter of the landfill were upgraded. By the end of the year, approximately 1,200 ft of the length was completed with GCL and backfilled.

During completion of the work on the southern tile, cuts were made into the banks of the landfill to install the tile system. In one area in where cuts were made, water was observed in the upper sections of the open cuts. As such, it was determined that an additional upper tile segment of approximately 1,000 ft should be installed in this area to support enhanced removal and management of the landfill (Figure 9-10).

9.4 Upgrades in 2019

The remainder of the south tile replacement, approximately 1,100 ft was completed with GCL and backfilled in early 2019.

A Hydraulic Report and Design package was then prepared for the north tile replacement and slurry wall repair and submitted to EGLE on June 3, 2019 (Appendix G). The design package was also presented and discussed with EGLE during the June monthly status update meeting.

Construction on the north tile and slurry wall repair was initiated in July. Approximately 475 ft of slurry wall was completed by October 2019. The planned 3600 ft of tile plus an additional 250 ft of upper tile were replaced on the northern perimeter of the landfill by the end of the year.

A similar situation to the one encountered during the southern tile installation the previous year also occurred during the installation of the northern tile. In an area where cuts had been made to install the tile system water was observed in the upper sections of the cuts. To enhance drainage in this area, an additional 250 ft of upper tile was installed on the northern perimeter during the construction effort (Figure 9-11).

One additional area was also observed on the southern perimeter of the landfill during construction. Design of an additional upper tile system began upon observation of this additional area (Figure 9-12). Construction is currently underway and expected to be completed within the first quarter of 2020.

9.5 Path Forward

The purge wells were sampled in early Q4 2019 and the plume analysis for that quarter will be completed in early Q1 2020. As the wells were only turned back on slightly before the Q4 2019 sampling event, the results of the plume analysis will likely show similar results in terms of plume area, concentration, and mass when compared to the analysis of Q3 2019.

The expanded optimization pilot monitoring network will continue to be gauged and sampled on a quarterly basis in 2020 and quarterly plume analyses will be completed with the data. The condition of the purge wells along with their purge rates and flow rates will also continue to be monitored on a monthly basis through 2020.

While the purge well optimization work will continue to focus on optimization of pump rates based on collected water quality data from the purge wells and expanded network, additional emphasis will be on assessing the effects of the slurry wall repair on the plume area. Since the apparently sourcing of the plume has now been cut off, it is expected that the plume area will retract throughout the year. Dependent upon the response of the plume, Dow may assess potential further management strategies necessary to address the remainder of the plume.

Throughout 2020 Dow will:

- Conduct monthly monitoring of well conditions
- Continue routine quarterly monitoring in purge wells
- Collect additional samples from wells 2549, 5924, and 5923 in order to support understanding of the plume migration and retraction
- Continue to examine trends in purge wells and in sentinel wells
- Take appropriate actions if the plume is not behaving as expected

- Adjust flow rates as appropriate to optimize performance

Work in 2019 is anticipated to be completed in accordance with the milestone schedule presented in Section 17.0. Unless otherwise necessary or requested plans or findings will be provided during periodic progress meetings, which are scheduled to occur on an approximately monthly basis. Annual updates detailing the work completed and projected for the next year will be presented in the annual CAIP.

10.0 NORTHEAST PERIMETER

The NEP is located along the north and east of the Midland Plant (Figure 10-1). Shallow groundwater in this area has been identified as having the potential for seasonal off-site migration and possible venting to storm sewers located along Washington Street, Bay City and South Saginaw Roads. Historic releases of organic contaminants have been identified by detection in groundwater monitoring wells, including benzene, trichlorofluoromethane (CFC-11), dichlorofluoromethane (CFC-21) and the organic daughter products and inorganic byproducts from natural attenuation of chlorinated ethenes.

10.1 Overview of Site Characterization and Interim Measures

A federal HSWA permit was originally issued to the Midland Plant on October 12, 1988. Included in the conditions of the permit were provisions that Dow was required to contain all contaminated groundwater on-site, and properly treat it through the WWTP. In addition, the corrective action plan for the facility at that time included maintaining old closed WMUs in-place, intercepting and treating shallow groundwater flowing underneath the Midland Plant, and continuing to study the hydrogeology as needed to develop a full understanding of groundwater flow relationships and potential environmental impacts of the Midland Plant and contiguous properties.

As part of the on-going study, EDI Engineering and Science completed a hydrogeologic study of the Midland Plant in March of 1989. Groundwater modelling performed as a part of this study identified areas where shallow groundwater could flow off-site from the Midland Plant, including the NEP of the Midland Plant along Saginaw Road and Bay City Road. A groundwater collection system was presumptively proposed for the area in May of 1990. Study of the area continued into 1993 to fill data gaps identified by MDEQ. Groundwater samples collected from the area were found to be free of contamination, so the plans to construct the groundwater collection system were withdrawn.

Development of a groundwater monitoring program for the NEP was outlined in the Operating License. Dow proposed to conduct additional investigation needed to finalize and implement a routine groundwater monitoring program. A groundwater monitoring program was developed and submitted to MDEQ on July 22, 2005. Based on MDEQ comments to the proposal, an addendum to the Monitoring Program was submitted on October 14, 2005. The groundwater monitoring program for the NEP was added to the RCRA Facility SAP in April 2006 and received MDEQ approval on September 27, 2007.

During implementation of the approved groundwater monitoring program at the NEP, vinyl chloride was detected in two monitoring wells (MW-6178 and MW-6175). Additional groundwater investigations were developed and implemented to determine the extent of the groundwater impacts. Summary reports for both the 6175 and 6178 Area studies were submitted to the MDEQ on September 14, 2007. Corrective Action Plans were submitted for these two areas (Area 6178 and Area 6175) on January 18, 2008.

Results of the 2007 study of the 6178 Area indicate that the vinyl chloride is a daughter product of higher chlorinated ethenes that are being naturally dechlorinated. At the downgradient boundary of the plume, the concentrations of the COCs were below the generic GSI criterion. Results of the 6175 Area study also indicate that the vinyl chloride is a daughter product of higher chlorinated ethenes that are being naturally dechlorinated; however, observations indicated that the dechlorination process may not progress to ethenes and ethanes, as observed in the 6178 Area, prior to entering the backfill of an existing storm sewer. This storm sewer eventually discharges to the Tittabawassee River, so corrective action was proposed.

In both areas, the initial source was determined to likely be a relatively small, historic release of higher chlorinated ethenes that have naturally dechlorinated in the groundwater and diffused into the lower clay soils. Monitoring wells from both areas were added to the existing bi-annual NEP groundwater monitoring program in the area. The purpose of the monitoring programs is to demonstrate on-going natural attenuation and ensure that concentrations of COCs are not increasing over time.

Dow also completed an investigation in 2008 near monitoring wells 3540A and 4358 (CFC Area) in the NEP due to detectable concentrations of trichlorofluoromethane (CFC-11) and dichlorofluoromethane (CFC-21). A GSI criterion has not formally been developed for CFC-11 or -21; however, the available toxicity data suggested that the criterion, if developed, may be lower than the concentrations detected in this area (URS, 2011).

Further investigation was proposed in the *Work Plan for CFC-11 and -21 Evaluation Near Wells 3450-A and 4358* submitted September 30, 2010 and the *Work Plan Addendum for the Northeast Perimeter Groundwater Monitoring Program* submitted for MDEQ review and approval on December 21, 2011.

Dow has continued to assess results from the on-going groundwater monitoring program for the NEP since its implementation. To assist with the assessment of the historical data, in 2016 Dow contracted with EarthCon to perform groundwater plume analytical services to help characterize the conditions in the NEP. Findings of their analyses conducted coupled with additional analyses of the monitoring data further defined additional investigation for the NEP to address the groundwater detections measured above generic MDEQ GSI and the concentrations of CFC-11 and CFC-21.

The 2016/2017 CAIP described the planned work activities for 2017, including the primary objectives of the work in each area. The planned activities included additional drilling work using a MiHPT and follow-up laboratory analyses to assess each area as defined at the time (Figure 10-2). The initial plan included the potential completion of MiHPT at regular intervals along investigative tracks, dependent upon the MiHPT and analytical results. Additionally, MiHPT borings were planned to be advanced at locations to the north of the facility to delineate the extent of the plume areas. The final MiHPT locations are found on Figure 10-3.

Each MiHPT boring included the use of multiple detectors (e.g. PID, flame ionization detector [FID], electron capture detector (ECD), HPT, halogen-specific detector (XSD), stratigraphy, etc.). Further, groundwater samples were planned to be collected from selected MiHPT borings in order to determine the relative distribution of target constituents based upon the MiHPT technology responses. A mobile laboratory was on-site to provide analytical services.

The target constituents for the 6175 and 6178 Areas included vinyl chloride; cis-1,2-DCE; trans-1,2-DCE; 1,1-DCE; TCE; and PCE. The target constituents for the CFC Area were trichlorofluoromethane (CFC-11); and dichlorofluoromethane (CFC-21).

As the plume areas were hypothesized to perhaps overlap or intersect, all analytes were analyzed in each groundwater sample.

The methodology and results of the 2017 investigative work was detailed in the 2017/2018 CAIP. The findings defined the limits of impacts of site COIs for each of the investigative areas: 6178 Area; 6175 Area; and CFC Area. The impacts in each of the NEP investigative areas were delineated through the implementation of MiHPT borings and focused groundwater sampling.

The MiHPT investigative program identified a DNAPL source area south of the 6175 Area in the vicinity of Building 433 to the northwest and Building 1268 to the southeast (Figure 10-4). Based upon the limited TAL, the DNAPL appeared to be predominantly comprised of PCE. Based upon review of the available hydrogeologic data for this portion of the NEP, this identified DNAPL area is likely the source of the impacts in the 6175 Area and could possibly also be the source of the impacts to the 6178 Area. The primary COIs identified for the 6175 Area included PCE, TCE, cis-1,2-DCE and vinyl chloride while the 6178 Area COIs were limited to cis-1,2-DCE and vinyl chloride. For DCE detections, cis-1,2-DCE comprises a significant percentage of the total DCE, therefore, it is inferred to represent a reductive dechlorination by-product of a PCE or TCE source.

For the CFC Area, the MiHPT investigative program and associated focused groundwater sampling program successfully delineated the impacts of the target CFCs. Both the sampling and MiHPT results

identified the source of the primary CFC-11 impacts to be located in the area between and north of Buildings 719 and 872, with lower level impacts in the area north of Building 564, which may be due to migration from the apparent source area based upon variable groundwater flow conditions in this portion of the NEP (Figure 10-5). The distribution of CFC-11 and its reductive dechlorination by-product CFC-21 are nearly coincident and appear to be bounded by hydrogeologic conditions in this portion of the NEP.

10.2 Conceptual Site Models

Based on the results of the 2017 investigation, refined CSMs were constructed for each of the areas.

10.2.1 6178 Area

For the 6178 Area, the developed CSM (Figure 10-6) depicts the coincidence of the impacts of COIs with an area of depressed elevation in the surface of the stiff clay unit, which serves as the base of the uppermost sand unit monitoring well network. Based upon the orientation of the clay surface, the monitoring network screened intervals, the observed localized groundwater flow conditions, and the proximity of the identified DNAPL source area to the southeast of the 6178 Area, the potential for impacts emanating from the DNAPL area to the 6178 Area exists. Further evidenced by the developed CSM is the likely presence of impacts within the clay unit, based upon the detections of COIs within monitoring wells screened predominantly below the uppermost sand unit (e.g. within the stiff clay unit).

With respect to data gaps for the 6178 Area, an area of limited data points exists between Building 433 and the existing monitoring network. Additionally, several of the existing monitoring network well locations (MW-I, MW-J) possess screened intervals above the clay unit while others (MW-A, MW-B, MW-C) have a majority of the screened interval within the clay unit. Further, no monitoring wells are located to the west of monitoring wells MW-J and MW-K, an area suggested to coincide with depression in the surface of the clay unit (e.g. uppermost sand thickening).

10.2.2 6175 Area

The developed CSM (Figure 10-7) for the 6175 Area also depicts the influence of hydrogeologic conditions on the distribution of COI impacts. The identified DNAPL source area was found to be present between elevation 612-616 ft, 3 to 5 ft below the uppermost sand and stiff clay unit contact. Downgradient (northerly) migration of dissolved phase impacts and potentially DNAPL appears to be controlled by several factors, including the slope of the clay unit, the thickening of the uppermost sand unit, and the resulting northerly groundwater flow pattern between the source area and the 6175 Area. Based upon these observations, the DNAPL area likely constitutes a continuing source area for the impacts to the 6175 Area.

With respect to COI fate, the MiHPT investigation identified a localized area near monitoring well MW-3 in which current vinyl chloride concentrations in excess of the GSI criteria (15 µg/L) likely extends beyond the northern property line of the Facility. However, based upon further downgradient groundwater sampling, the migration appears to attenuate to ND levels within 200-300 ft. Further delineation of the northernmost extent of the COIs may be warranted. Additional data gaps include optimization of the monitoring well network as several monitoring wells (MW-2, MW-5, MW-7, MW-8, and MW-9) possess screened intervals above the clay unit.

10.2.3 CFC Area

The CSM prepared for the CFC Area (Figure 10-8) was developed based upon the results of the MiHPT investigation and limited to CFC-11 and CFC-21 COIs. The CFC impacts were also determined to be largely controlled by the hydrogeologic conditions in this portion of the Facility. Specifically, the migration of CFCs is northeast, consistent with the observed groundwater flow direction before forming two distinct dissolved phase lobes to the northwest and east-southeast in the vicinity of monitoring well MW-3540A

where the uppermost sand unit thins due to an apparent ridge-like feature in the stiff clay unit in this portion of the Facility. This assessment can be confirmed as monitoring well MW-4359, installed within the ridge-like feature, is periodically noted to be dry.

The results of the MiHPT investigation successfully delineated the CFC impacts and noted that impacts were observed within both the uppermost sand unit as well as the stiff clay unit, suggestive of a surface source.

Therefore, identified data gaps for the CFC Area are limited to optimization of the CFC Area monitoring network and the collection of pre-design sampling data in order to facilitate remedial technology screening and selection, if warranted.

10.3 Current Status

Work in 2019 has focused on assessing potential remedial technologies, developing the work plan to gather additional site data to fill data gaps, collect remedial design data, and develop the well network optimization plan.

During 2019, preliminary remedial technology screenings were performed for the 6175 and 6178 areas and alternative technologies were explored for the CFC area. A preliminary workplan for the data gap analysis was developed; however, during the development of the workplan it was determined that refinement of the conceptual site model would be prudent prior to another field mobilization. As such, a high-resolution CSM applying Environmental Sequence Stratigraphic (ESS) analysis will be developed for the plume areas prior to finalizing the workplan for the next phase of the field effort. The refined CSM will be completed by reviewing and interpreting previously-acquired site subsurface lithology data to assess the connectivity of transmissive sediments at the site to better evaluate potential contaminant flow pathways.

It is also anticipated that after the gap analysis is completed that a well network optimization plan will be implemented based on the results. A preliminary plan was put together in 2018 and discussed with the EGLE during the monthly status meetings; however, plans have not yet been finalized due to the need to collect additional data.

10.4 Path Forward

Work in 2020 will focus on achieving the following objectives for the NEP:

- Development of high-resolution CSM
- Modification of field work plan for the collection of additional data necessary to fill CSM data gaps and for bench studies
- Implementation of data gap workplan to collect additional data necessary to complete bench studies
- Complete bench studies as appropriate for selected remedial technologies.
- Evaluate 2020 data collected and modify the well network optimization plan

Work in 2020 is anticipated to be completed in accordance with the milestone schedule presented in Section 17.0. Unless otherwise necessary or requested plans or findings will be provided during periodic progress meetings, which are scheduled to occur on an approximately monthly basis. Annual updates detailing the work completed and projected for the next year will be presented in the annual CAIP.

11.0 CHEMICAL DISPOSAL WELL #3

Closed Chemical Disposal Well #3 is located east of Poseyville Road within the Midland Plant (Figure 11-1). The well was formerly used for injection of wastewater. It was closed in 1985 and a groundwater collection tile and pumping station was installed in the immediate area prior to 1990 to capture groundwater and prevent off-site flow. Hydraulic monitoring of the system through the use of piezometers began in 2004.

The potential for off-site groundwater flow at the western boundary of the facility was identified and reported to the MDEQ in the Compliance Schedule Task H-11 West Side Shallow Groundwater Investigation Summary Report dated August 7, 2009. Off-site flow was determined to have the potential to vent to storm sewers that were present at that time which drained southwards, eventually discharging to the Tittabawassee River downstream of the Dow Dam. IMs continued in 2011 to address the issues identified at the site, as described below.

11.1 Overview of Site Characteristics and Interim Measures

Work completed in association with the H-11 project included a characterization of groundwater quality in the area by collecting a groundwater sample from facility shallow monitoring well MW-6172 (Figure 11-1) and analyzing it for the presence of constituents listed in 40 Code of Federal Regulations (CFR) Appendix IX. Chlorobenzene was detected at a concentration exceeding generic GSI criteria. Supplemental soil and groundwater characterization were then completed in 2011 and early 2012. Results were used to evaluate the exposure pathways at the relevant properties affected by this contamination. An IRA Work Plan was submitted on March 16, 2012 to address venting to surface water and dermal contact to groundwater and the work described in the Plan was completed in the summer and fall of 2012.

The 2012 IRA included a source removal activity and approximately 5,280 cubic yards of existing contaminated soil was removed and disposed of at Salzburg Landfill. Due to the presence of three existing active utilities that remain in place (8-inch Consumer's Gas Main, 12-inch High Pressure Maverick Natural Resources, LLC High Pressure Gas Main, City of Midland 10-inch Water Main), contaminated soils remained in place after completion of the IRA (Figure 11-1).

Four cross-ties linking the sewers on each side of the road potentially acted as preferential flow paths. Three cross-ties were subsequently physically removed, and the fourth (4th) cross-tie, a 60-inch culvert, was plugged with flow fill. A 30-ft clay plug was also installed on the eastern boundary of the culvert to minimize flow along the backfill. To provide for proper drainage after removal of the sewers, the following drainage enhancements were completed:

- Relocated the north branch of the Hardy Drain to drain beneath Poseyville Road (north of the subject site);
- Regraded the Dow West Property to direct roadway and other surface drainage to the north towards the newly relocated north branch of the Hardy Drain; and
- Regraded the Dow East Property to direct roadway runoff northwards to the newly relocated north branch of the Hardy Drain.

Supplemental soil and groundwater characterization were completed in 2016 and 2018 to evaluate the exposure pathways at the relevant properties affected by the contaminated soils left in place. The objective of this work was to determine if impacted groundwater exceeding the MDEQ groundwater-surface water interface (GSI) criteria is flowing offsite with the potential of impacting GSI receptors in the area.

11.1.1 Work Completed in 2018

In order to assess the GSI pathway and develop further actions as necessary, the following actions were conducted during 2018.

In late March to early April of 2018 groundwater samples were collected from shallow wells 2925, 8815, 8816, 8817, 8818, 8819, 8820, 2926A, 2927A and deep wells 2925A, 2926, 2927, 3142, 3143, 3144. The samples were analyzed for a suite of analytes including metals, pesticides, polychlorinated biphenyls (PCBs), herbicides, VOCs, and semivolatile organic compounds (SVOCs).

In August of 2018, the collection of SWLs began continued into December 2018. Monitoring well top of casings (TOCs) were resurveyed on September 19, 2018 to 0.01-inch. A topographic survey was also completed.

In early March of 2018, slug tests were performed at each shallow piezometer 8815, 8816, 8817, and 8818 to determine the hydraulic conductivity of the shallow formation. Four slug tests were performed at each piezometer consisting of two falling head and two rising head tests varying the slug displacement between each test.

11.2 Work in 2019

Work in 2019 focused on evaluating the data collected in 2016 and 2018, developing a monitoring plan for further assessment in 2019 based on that data, and beginning the further evaluation of the new site data.

11.2.1 Assessment of 2016 and 2018 Shallow Groundwater Data

To determine the shallow groundwater flow direction, bi-weekly SWLs were collected from September 2018 through the end of December 2018 at the shallow monitoring well locations. The shallow groundwater flow direction was determined to be to the west, in concurrence with the 2016 data collected (Figure 11-2).

Surface water bodies identified with the potential to have groundwater influence from the CD-3 site are the shallow north-south trending swale on the east side of Poseyville Road and the north-south trending ditch approximately 175 ft west of the CD-3 site on the west side of Poseyville Road. A storm water sewer also trends north-south along the west side of Poseyville Road approximately 170 ft west of the CD-3 site.

A TOC survey was completed in August 2018 along with a topographic survey of the ditch located west of Poseyville Rd. The potential for groundwater to vent to the ditch on the west side of Poseyville Road was confirmed when comparing groundwater elevations at shallow monitoring wells 8817 and 8818 to the elevation of the bottom of the west ditch. Groundwater elevations in shallow monitoring wells 8817 and 8818 are at the approximate elevation of the bottom of the ditch. Surface water in the ditch ranges from several feet during flood events to a few inches during normal conditions. During periods of low precipitation and warm temperatures the ditch may be dry. Groundwater is not expected to vent to the shallow swale to the east of Poseyville Road based on the survey data.

The 2016 and 2018 shallow groundwater sampling results were compared to the Michigan Part 201 GSI Criteria. Monitoring wells 2925, 2926A, 2927A, 8816, 8817, and 8819 had chemistry that exceeded various GSI criteria in 2016. Monitoring wells 2926A and 8819 had chemistry that exceeded various GSI criteria in 2018. Tables 11-1 and 11-2 summarize the 2016 and 2018 shallow monitoring well detections compared to the GSI criteria.

The GSI criteria for barium, chromium, copper, lead, nickel, and zinc are dependent on the hardness of the receiving water, and the GSI criteria for pentachlorophenol is dependent on the pH of the receiving

water. A hardness sample and pH measurement were collected on January 8, 2019 of the ditch west of Poseyville Road. The pH was measured at 7.87 standard units (S.U.) and the hardness was 320 milligrams per liter (mg/L) calcium carbonate (CaCO₃). Figure 11-3 shows the approximate area of GSI exceedance for the 2016 sampling event and Figure 11-4 shows the approximate area of GSI exceedance for the 2018 sampling event.

Shallow monitoring wells 8817 and 8818 are the current GSI compliance points and were installed to intercept any offsite groundwater flow from the east side of Poseyville Road before reaching the ditch and storm sewer. For the 2016 sampling event, MW-8817 was over the GSI criterion for Cyanide at 0.110 mg/L. The GSI criterion for cyanide is 0.0052 mg/L. Cyanide was analyzed using the waste and leachate-based method of SW9012A with a reporting limit of 0.010 mg/L.

Compliance with the Michigan GSI criterion for cyanide requires use of Method OIA-1677 or comparable for determination of amenable cyanide with a reporting limit of 0.005 mg/L. There were no cyanide detections for the 2018 sampling event using Method SW9012A and a reporting limit of 0.010 mg/L. It should be noted that MW-8817 and MW-8818 were purged dry during the 2018 sampling event and samples collected after the wells recharged the following day.

11.2.1.1 Hydraulic Conductivity Assessment

In March of 2018, AECOM performed slug tests in shallow monitoring wells 8815, 8816, 8817, and 8818 (Figure 11-1). Slug tests were not performed at other shallow monitoring wells as the well diameters of 1.0 to 1.25 inches did not allow use of the downhole equipment designed for wells 2 inches in diameter.

Slug tests were intended to be performed by completing falling head and rising head slug tests using slugs that displace approximately 0.53 ft and 1.15 ft. A rising head test at MW-8815 was not completed using the 1.15-foot displacement slug due to an extremely slow response observed in previous falling head slug test using the 0.52-foot displacement slug. Data from the previous falling head test at MW-8815 showed interference from regional shallow groundwater fluctuations over the long duration of the slug test. The interference also impacted the other falling and rising head slug tests at MW-8815 making an accurate analysis of MW-8815 difficult. Slow response is indicative of a low hydraulic conductivity equal to or less than 1×10^{-6} centimeter per second (cm/sec). Slug test data was analyzed with the Bouwer and Rice method for unconfined formations as well as the Cooper method for confined formations as outlined in *The Design, Performance, and Analysis of Slug Tests* by James J. Butler. Conductivity values range from 0.005 cm/sec at 8816 to 1.77×10^{-6} cm/sec at MW-8815. Measured hydraulic conductivities are typical for the lithology observed in the soil borings for shallow monitoring wells 8815, 8816, 8817, and 8818.

11.2.1.2 Deep Well Chloride Impact Assessment

Existing samples results from the deep wells on site were analyzed to determine if the chloride impacts are limited to the area around deep well 3143.

Groundwater levels were collected at deep monitoring wells 2925A, 2926, 2927, 3142, 3143, and 3144 (Figure 11-1). The deep groundwater flow direction is to the west-southwest towards PLF. Due to depth and direction, groundwater in the deeper aquifer is unlikely to vent to the nearby shallow GSI receptors.

Evaluation of past deep groundwater monitoring events shows groundwater exceeds various MI Part 201 Generic Residential Drinking Water Criteria. Deep monitoring wells 3142, 3143, and 3144 were sampled for volatiles, semi-volatiles, herbicides, pesticides, metals, and cyanide in January and March of 2016. Chloride and Stiff parameters were added to the March 2016 sampling event for MW-3143.

Iron, chloride, and sodium were detected in MW-3143 during the March 2016 sampling event over the MI Part 201 Generic Residential Drinking Water Criteria. Silvex, isophorone, and EDC were detected at various deep monitoring wells significantly below the MI Part 201 Generic Residential Drinking Water

Criteria during the January and March 2016 sampling event, though isophorone and EDC were detected in one of the trip blanks indicating potential field or laboratory interference. Deep groundwater detections from the 2016 sampling events are shown on Table 11-3.

In 2018, deep monitoring wells 2925A, 2926, 2927, 3142, 3143, and 3144 were sampled for metals, chloride, and stiff parameters. Chloride, lead, vanadium, and iron were detected in deep monitoring wells over the MI Part 201 Generic Residential Drinking Water Criteria in 2018. Deep groundwater detections from the 2018 sampling events are shown on Table 11-4. The results from all wells sampled besides 3144 indicated chloride impacts.

11.2.2 Shallow Groundwater Monitoring Program Development and Implementation

The 2016/2018 data assessment provided sufficient information to establish a site-specific TAL and determine that further sampling should be conducted to better evaluate the site (Table 11-5). The proposed short-term monitoring program was presented and discussed in the May 2019 monthly Dow/EGLE Corrective Action Status meeting. The current monitoring program is currently expected to include eight sampling events over a 16-month period.

The monitoring program developed includes bimonthly sampling at six shallow wells (8817, 8818, 8819, 8820, 2926A and new location to be installed west of 2926A) for the site-specific TAL, SWL measurements at seven shallow groundwater well locations (8815, 8816, 8817, 8818, 8819, 8820, and 2926A), and pH and hardness sample collection from the north-south trending ditch west of Poseyville Road for calculation of GSI criteria (Figure 11-5). Prior to sampling all wells are developed using surge and pump techniques to remove any residual turbidity from past flooding events.

To address the potential for offsite flow near monitoring well 2926A, the additional well is to be installed on the west side of Poseyville Rd. directly west of 2926A. The well was intended to be installed prior to beginning of the bimonthly groundwater sampling but due to the need to obtain property use license agreements to install the monitoring well on City of Midland Property, the installation has been delayed. It is anticipated to be installed prior to the April 2020 groundwater sampling event.

The results for two groundwater sampling events were available as of December 2019. There have been no exceedances of the GSI Criteria at GSI compliance monitoring wells 8817 and 8818 for either of these events. The reporting limit for amenable cyanide was reported as 0.010 mg/L for the August and October groundwater sampling. As the GSI criterion for cyanide is 0.005 mg/L future sampling events will be analyzed to reporting limit of 0.005 mg/L. The results of the August and October groundwater sampling events is included as Table 11-6.

Groundwater flow direction for the August and October sampling events was also to the west for both sampling events.

11.3 Path Forward

The short-term bimonthly groundwater sampling is expected to be executed for a minimum of 16 months, dependent upon the results. Therefore, this sampling effort will continue through the majority of 2020. After collection of a full dataset, analytical results will be evaluated, and appropriate next steps will be developed.

Work in 2020 is anticipated to be completed in accordance with the milestone schedule presented in Section 17.0. Unless otherwise necessary or requested, plans or findings will be provided during periodic progress meetings, which are scheduled to occur on an approximately monthly basis. Annual updates detailing the work completed and projected for the next year will be presented in the annual CAIP.

12.0 7TH STREET PURGE WELLS AREA (FUEL OIL TANK FARM)

The former fuel tank farm AOC, known as 7th Street Purge Wells AOC, is located in an upland area on the west bank of the Tittabawassee River, approximately 520 ft upstream of the Dow Dam (Figure 12-1). Historically, two above-ground fuel oil storage tanks were located in the area. The tanks provided fuel oil to a backup boiler located in Building 879. Historic release(s) from the operation of this above-ground storage tank system and associated piping have impacted the soil and groundwater. The area has been extensively backfilled with ash, sand, gravel, bricks, crushed concrete, asphalt, coal, and various other man-made materials. The shallow perched groundwater exhibits an easterly hydraulic gradient towards the Tittabawassee River. Thin silts and clays underlie the fill material. The silts and clays form a thin aquitard over the large sand inclusion in the till that is in hydraulic communication with the Tittabawassee River channel. Work has been focused on managing both the shallow perched groundwater as well as the deeper groundwater hydraulic zones.

12.1 Overview of Site Characterization and Interim Measures

The 7th Street Purge Well Area is currently an industrial area including paved and gravel roadways, a service water pump house, and above ground utility truss supporting utilities which cross the Tittabawassee River via either of two bridges spanning the River at the eastern extent of the study area (Figure 12-2). Groundwater pumping wells (purge wells) are operated in the area as stipulated by RCRA License operating conditions. Along the eastern margin of the study area, the Tittabawassee River flows from north to south at levels generally around 597 ft NAVD 29. A service water intake basin was constructed along the west portion of the Tittabawassee River within the study area, partially separated from the main flow channel by a steel sheet pile wall.

12.1.1 Shallow Zone Interim Measures

An IRA Work Plan was submitted December 13, 2005, and a Completion Summary Report provided September 28, 2007. The IRA investigation included the installation of a number of groundwater monitoring wells in the shallow zone (Figure 12-3). Groundwater sampling identified chromium, lead, and various volatile organic hydrocarbons including naphthalene. The highest groundwater concentrations of the COCs were detected in MW-4 and MW-7. The groundwater concentrations in MW-4 and MW-7 occasionally exceeded the GSI criteria.

Measurable free product was identified in monitoring wells MW-9, MW-10, MW-11, and MW-13. An intermittent heavy sheen of free product has been noted in MW-7. The free product is dark brown to black in color and highly viscous (e.g., not mobile). Analytical data confirms the oil is viscous and lighter than water. A map indicating the estimated extent of the area impacted by free product is attached as Figure 12-4.

The silt and clay aquitard undulates across the site, is generally at a higher elevation along the riverbank and is restricting or retarding the movement of groundwater towards the river. The aquitard is present at the highest level along the riverbank near MW-17 and MW-18 and lowest along the riverbank near MW-1 and MW-6.

During routine monitoring, seven compounds were detected at concentrations above their GSI Cleanup criterion, following the April 2, 2013 sampling of corrective action wells MW-15S, MW-14S, MW-18, and MW-17. The MDEQ was verbally notified on June 10, 2013, and the wells were re-sampled on June 13 and 17, 2013. Detected concentrations of 1,2,4-TMB, ethylbenzene, and naphthalene were confirmed to be at concentrations exceeding their GSI Cleanup Criterion. 1,2,4-TMB was identified in one sample at concentrations that also exceed the Michigan Rule 57 Final Acute Value. MDEQ was notified of the confirmation on July 8, 2013.

In response to the chemical detections in the corrective action monitoring wells that exceeded generic MDEQ Cleanup Criterion, an IRA Work Plan was submitted August 2, 2013, summarizing the IMs that

included targeted removal of 'source' material in the area. The interim response was designed in order to improve the groundwater quality sufficiently enough that generic Cleanup Criterion will not be exceeded. During the fall of 2013, soil was excavated to the top of the aquitard and impacted soil was removed from the area. Approximately 5,000 cubic yards of 'source' material was removed (Figure 12-5). The area was backfilled with excess soils re-located from other areas on-site. Immediately following the source removal detections of arsenic, 1,2,4-TMB, ethylbenzene, isopropylbenzene, o-xylene, naphthalene, and cyanide were detected above the generic GSI cleanup criteria but were either not confirmed in follow-up sampling or the wells were dry.

12.2 Shallow Zone Current Status

Existing shallow monitoring wells 14S, 15S, 17, and 18 routinely dry or they go dry during sample collection except when seasonally induced higher water levels (snow melt, rain, etc.) exist, which presents a significant challenge to routinely and effectively evaluate the shallow groundwater against Performance Criteria. Historically, groundwater samples collected from MW-18 in second quarter have exceeded the Michigan Part 201 GSI cleanup criteria for VOCs, SVOCs and occasionally metals.

In the second Quarter of 2017, a sample was obtained from MW-18 and 1,2,4-TMB, ethylbenzene, o-xylene, naphthalene, and m,p-xylene was detected (with results of 74 micrograms per Liter ($\mu\text{g/L}$), 220 $\mu\text{g/L}$, 22 $\mu\text{g/L}$, 43 $\mu\text{g/L}$, and 44 $\mu\text{g/L}$, respectively) above the performance criterion for each of these analytes. Per the requirements of the SAP, MW-18 was then resampled in quadruplicate on August 2, 2018 and the results confirmed the VOC exceedances.

Water was again observed in MW-18 during the Q3 2018 chemical monitoring sampling event completed on August 28, 2018. The results reported that arsenic, and additional organic constituents in the sample collected at MW-18 did not meet Performance Criteria established in Table 2-F of the SAP (Table 8-1).

Table 12-1. Constituents Detected Above Performance Criteria in MW-18 in 3rd Quarter 2018

Analyte	Result ($\mu\text{g/L}$)	Criteria ($\mu\text{g/L}$)
1,2,4-Trimethylbenzene	310	17
1,3,5-Trimethylbenzene	51	45
Ethylbenzene	510	18
Isopropylbenzene	83	28
o-Xylene	500	41
2-Methylnaphthalene	31	19
Naphthalene	380	11
m,p-xylene	260	41
Arsenic	36.7	10

MDEQ was notified of the Q2 exceedances in a letter sent to MDEQ on September 7, 2018 and of the other GSI exceedances via a phone call on September 24, 2018 followed by a confirmation email sent the same day. Per the requirements of the SAP, MW-18 was resampled in quadruplicate on October 3, 2018 and the results confirmed the exceedances.

12.2.1 Work in 2019

In response to the shallow zone criteria exceedances at MW-18, pursuant with Condition IX.B.2.(c).(iii) and (iv) of the Operating License, a work plan was developed to put together a more complete CSM in order to design an effective remedial strategy to address the GSI exceedances found in MW-18.

A historical boring logs review was conducted. Historic boring logs in the 7th Street Purge Well Area and in the Tittabawassee River were reviewed to generate cross-sections of the area (Figures 12-6 thru 12-9). The presence of historical river banks under fill are evident in the cross sections demonstrating the groundwater flow is complex in the area and there are potentially many unconnected perched groundwater zones.

A historical aerial photograph and drawing review was also completed to review the location of former bulk tanks, dispensing facilities, power houses and assess potential impacts of existing structures in the area including the bridge design. The original bridge design drawings from the 1920's revealed that the edge of the wing wall extends well below the upper shallow aquifer and that water in MW-18 may be trapped perched groundwater (Figure 12-10).

Groundwater and surface water data in the area were also reviewed. Groundwater elevation data demonstrates that groundwater in MW-18 tracks directly with the Tittabawassee River level, while the other monitoring wells in the area do not (Figure 12-11).

Once all the existing data was reviewed, it was determined that the next step would be to evaluate the extent of the groundwater that exceeds the GSI criteria north of MW-18 and evaluate the groundwater that is flowing towards MW-18. To do this Dow developed a workplan to install two new monitoring wells north of MW-18 along the fence line (MW-9472 and MW-9473) and one additional well to the west of MW-18 (MW-9474) (Figure 12-12). The new wells were completed on July 10 and 11, 2019 with the use sonic drilling due to buried concrete debris in the area. Boring logs for the new well locations are included as Appendix H). The wells are screened in the base of the fill and a few feet of silty riverbank sediment. The bottom of the wells are set on the brown clay separating the upper perched groundwater from the underlying sand layer that is controlled by RGIS.

During well installation, the field team noticed a water main leak in the area adjacent to MW-17. MW-17 has historically been dry; however, during this event had water flowing out of the ground alongside the casing. The leak was repaired during the installation of the wells.

The wells were then developed on July 15, 2019. The new wells only contained a few milliliters of groundwater upon initiation of development and remained dry after pumping. The following week, the sampling team attempted to sample wells. MW-16, MW-17, MW-9472 and MW-9473 were dry. The only well that contained a small amount of groundwater is MW-18.

Subsequently, since the water main leak was repaired MW-18 has been dry during each attempt to sample. This suggests the area of groundwater exceeding the GIS is very limited and potentially only a small area along the bridge wing wall. It is also possible the groundwater in MW-18 may have been influence by the water main leak near MW-17.

12.3 Path Forward

Due to the discovery of the water main leak and the fact that MW-18 has subsequently been dry during each sampling attempt, Dow proposes to continue to monitor the wells in the area to gather data over the next four quarters throughout 2020.

Once the data has been collected for another year, Dow will assess the data set and revise the site CSM accordingly. As appropriate, Dow may pursue removal of this well from the Corrective Action Monitoring Program or propose alternative GSI compliance monitoring location.

Work in 2020 is anticipated to be completed in accordance with the milestone schedule presented in Section 17.0. Unless otherwise necessary requested plans or findings will be provided during periodic progress meetings, which are scheduled to occur on an approximately monthly basis. Annual updates detailing the work completed and projected for the next year will be presented in the annual CAIP.

13.0 MARK PUTNAM ROAD AOC

In late October 2018, a new AOC south of Mark Putnam Road and east of South Saginaw Road extending to the south and east an indeterminate distance was confirmed when analytical results were received for a soil sample taken after an odor was detected during the removal of a tree in the area.

The location of the AOC based on the soil sample results is found on Figure 13-1. Pursuant to Condition XI.F.1 of the Act 451 Part 111 of the Operating License Dow communicated the identification of this new AOC to the DEQ on November 16, 2018.

13.1 Summary of Initial Conditions

The Mark Putnam AOC was discovered when prepping the site for installation of a storm sewer to the south of Mark Putnam. Upon discovery of the impacted soil, the installation of the storm sewer was stopped. The sewer installation was redesigned to minimize potential infiltration into the storm sewer and storm sewer bedding backfill.

Installation of the revised storm sewer resumed in January 2019. The trench was excavated to depth for the storm sewer and all soil and debris was disposed of in Dow's Salzburg Landfill. A continuous high-density polyethylene (HDPE) sewer pipe was installed starting at the Saginaw Road storm sewer tie in and installed approximately 40 ft to the east of the initial impacted soil discovery location. Prior to installation of the HDPE Sewer Pipe an HDPE Sheet was placed in the trench directly on the undisturbed native soils of the excavation and extended up the side walls. The bedding for the HDPE Pipe was placed on top of the HDPE sheet prior to lowering the HDPE sewer pipe into place. Remaining bedding and backfill material were placed around the HDPE storm sewer. The HDPE liner was folded over the backfill and welded to itself. A bulk head was formed at each end of the HDPE liner by welding and clamping the HDPE sheet to the HDPE sewer pipe at the Saginaw Rd. storm sewer tie in and 40.0 feet east of the location of the initial impacted soils discovery. The remaining open excavation was backfilled with clean soils.

The new AOC is not a release from any known WMU. Analytical data from initial sampling of the impacted soil encountered during construction activities in the AOC are summarized in Table 13-1. Dow has not been able to identify any specific process or WMU operation associated with this area. A review of aerial photographs suggests that some type of industrial activity took place in the area of the new AOC at some point after 1952 and before 1983. No additional information is currently available on the specific industrial activity that took place in this area.

Table 13-1. South of Mark Putnam Road Soil Testing Results

Sample Name	Analytical Method	CAS	Compound Name	Result Value	Reporting Limit	Unit
MARK PUTNAM RD SOIL	SM2540B	SOLID	% SOLIDS	85.3	0.1	%
	SW6020	7440-38-2	ARSENIC	1400	1100	ug/kg
	SW6020	7440-39-3	BARIUM	30000	1100	ug/kg
	SW6020	7440-47-3	CHROMIUM, TOTAL	10000	450	ug/kg
	SW6020	7439-92-1	LEAD	11000	230	ug/kg
	SW8260B	120-82-1	1,2,4-TRICHLOROBENZENE	150000	17000	ug/kg
	SW8260B	95-50-1	1,2-DICHLOROBENZENE	55000	17000	ug/kg
	SW8260B	541-73-1	1,3-DICHLOROBENZENE	3500	340	ug/kg
	SW8260B	106-46-7	1,4-DICHLOROBENZENE	28000	17000	ug/kg
	SW8260B	71-43-2	BENZENE	3200	340	ug/kg
	SW8260B	156-59-2	CIS-1,2-DICHLOROETHYLENE	1000	340	ug/kg
	SW8260B	100-41-4	ETHYLBENZENE	1600	340	ug/kg
	SW8260B	127-18-4	TETRACHLOROETHYLENE(PCE)	28000	17000	ug/kg
	SW8260B	108-88-3	TOLUENE	590	340	ug/kg
	SW8260B	79-01-6	TRICHLOROETHYLENE (TCE)	4300	340	ug/kg
	SW8260B	XYLENES	XYLENES, TOTAL	1900	690	ug/kg
	SW8270C	634-66-2	1,2,3,4-TETRACHLOROBENZENE	260000	7000	ug/kg
	SW8270C	95-94-3	1,2,4,5-TETRACHLOROBENZENE	170000	23000	ug/kg
	SW8270C	92-52-4	BIPHENYL (DIPHENYL)	11000	580	ug/kg
	SW8270C	118-74-1	HEXACHLOROBENZENE	1600	170	ug/kg
SW8270C	91-20-3	NAPHTHALENE	180	170	ug/kg	

13.2 Work in 2019

Work in 2019 focused on the development of a work plan to investigate the AOC. The workplan was prepared and presented at the February 2019 Dow/EGLE CA Status meeting. The workplan included advancing soil boring to approximately 18' bgs to determine lithology and the extent of soil impacts. Samples would be collected every 3 feet. Since the amount of information on the site was very limited, it was anticipated that the number of boring would initially be based on field observations and photoionization detector (PID) readings taken near the material at each location. Groundwater was also planned to be investigated with the installation of shallow monitoring wells, collection of groundwater elevation data, and groundwater samples to be analyzed for compounds on the project specific TAL. After initial development of the workplan, it was determined that the soil DC pathway should also be investigated on the site.

13.2.1 Fieldwork

13.2.1.1 Soil Borings

Seven soil borings (SB) were advanced at the Mark Putnam AOC starting March 25, 2019 (Figure 13-2).

Soils were screened in the field by placing soils in plastic bags, allowing the soil to rest for 5 minutes and a reading collected from the headspace of the sandwich bag using an 11.7 eV PID. In addition to the PID soil headspace screening, soil samples were collected from all borings every 3 feet to approximately 18 feet bgs and submitted to Test America North Canton for laboratory analysis.

SB-9444 was advanced at the location where evidence of impacted soil was first discovered. SB-9445, SB-9446, SB-9447 and SB-9449 were offset approximately 75.0 feet from SB-9444 to the east, west, south and north direction respectively.

SB- 9445, SB-9446 and SB-9449 indicated no impact from PID soil headspace screening. PID soil headspace screening indicated impacts at SB-9447. SB-9448 and SB-9450 were advanced

approximately 37 feet west and east of SB-9444 respectively. PID soil headspace screening indicated soils at SB-9448 and SB-9450 were impacted.

Further delineation to the south and or north of SB-9447 or to the north between SB-9449 and SB-9444 were held to be determined based on review of the analytical results. Further delineation north of 9444 will also require a road closure to advance a soil boring in Mark Putnam Rd.

The soil borings indicate the lithology at the Mark Putnam AOC consists of a sandy clay to a depth of 4.0 feet bgs overlying a 1.0 to 1.5-foot-thick sand layer. Below the sand layer is a hard brown sandy clayey to 27.0 feet BGS. A soft to firm moist to wet brown silt is encountered to the extent of the boring at 36.0 feet bgs.

13.2.1.2 Groundwater Investigation

On July 26, 2019 monitoring wells (MW) were installed at SB-9444, SB-9445 and SB-9447 (Figure 13-3). The monitoring wells were constructed using 2-inch 10 slot schedule 40 screens 5 feet in length installed in a 6-inch diameter borehole at depths ranging from 7.0 to 7.5 feet bgs. The monitoring wells were screened to intersect the surficial sand layer. After installation, monitoring wells were developed using surge and pump methods to remove excess turbidity from well installation.

Monitoring wells 9444, 9445, 9447 and existing well 3654 were sampled using low flow methodologies in the Third Quarter of 2019.

13.2.1.3 Direct Contact Investigation

In the fourth quarter of 2019 a 1.4-acre DU was created encompassing the Mark Putnam AOC (Figure 13-4). The DU was sampled for Dioxins/Furans, VOCs, SVOCs, herbicides, pesticides, metals and PCBs using ISM. A total of 50 soil Increments were collected from 0 to 6.0 inches in depth and composited into one sample. The composited sample was sent to Test America North Canton for all analyses except for Dioxins and Furans which were submitted to The Dow EAC lab.

13.2.2 Data Analysis

13.2.2.1 Soil Investigation Results

Soil results indicate a circular plume centered around soil boring 9444. Soil impacts at 9444 extend to 35.0 feet below grade surface and taper up to less than 3.0 feet bgs as indicated by analytical data for borings 9445, 9446, 9447 and 9449 (Table 13-2).

Impacts at 9444 are below all criteria at 30.0 feet bgs and deeper except for methylene chloride which exceeds the Nonresidential Volatilization to Indoor Air Criteria (VIAC) for a 12- hour work-day exposure that apply to a nonresidential structure < 50,000 ft2 with a slab-on-grade, a depth to water of 5.0 feet and a USDA soil type of sand. Exceedances of the Michigan Part 201 Statewide Default Background (Background) Criteria for metals occur consistently at all depths and in all borings.

Due to the collection of the soil DC data in 4th quarter 2019, the results of the incremental sampling will be reviewed in 2020.

13.2.2.2 Groundwater Investigation Results

Results of the groundwater sampling are included in Table 13-3. Groundwater impacts are concentrated in MW-9447 and MW-9445 with exceedances of the Michigan Part 201 Non-Residential Drinking Water (Drinking Water) Criteria and Michigan Groundwater Venting to Surface Water Interface (GSI) Criteria. Benzene exceeded the drinking water criteria in MW-9444. There were no detections in MW-3654 over any criteria.

A groundwater flow direction map was created for the September 24, 2019 groundwater elevations showing a northerly flow direction and is shown on Figure 13-3.

13.3 Path Forward

Work in 2020 will focus on filling the data gap from the initial investigation. The existing soil results will be analyzed to determine if metals concentrations are the result of past industrial activity or naturally occurring background values. A review of soil background values will be completed according to *Soil Background and the Use of the 2005 Michigan Background Soil Survey – Resource Materials* approved by EGLE on October 4, 2019.

Results of the DC incremental soil sampling will be evaluated against DCC. A work plan will be developed for cover or removal and replacement of surficial soils exceeding DCC if necessary.

Further delineation of the soil contamination between SB-9444 and SB-9447 to the south and SB-9449 to the north will be completed to understand the depth of soil impact. The soil analyte list will be reduced to metals, cyanide, VOCs, and SVOCs as there were no detections of herbicides and pesticides in previous soil samples.

Additional delineation of the groundwater plume is required to understand the north, east and southern extent of the groundwater plume. Installation of a monitoring well along the sewer back fill adjacent to the ditch to the east will confirm the effectiveness of the storm water backfill infiltration mitigation. A deep monitoring well will be installed adjacent to MW-9444 in the moist to wet silt encountered at 27 feet BGS to determine groundwater impact at depth. The ground water analyte list will also be reduced to metals, cyanide, VOCs and SVOCs as there were no detections of herbicides and pesticides in previous groundwater samples.

Potential alternatives to address the delineated soil and groundwater impacts will be reviewed based on the results of the additional data collected.

Work in 2020 is anticipated to be completed in accordance with the milestone schedule presented in Section 17.0. Unless otherwise necessary or requested, plans or findings will be provided during periodic progress meetings, which are scheduled to occur on an approximately monthly basis. Annual updates detailing the work completed and projected for the next year will be presented in the annual CAIP.

14.0 FORMER ASH POND AOC

The Former Ash Pond was constructed as a cooling pond in the late 1940/50s to cool water from the on-site coal fired power plant prior to discharge to the Tittabawassee River. The Ash Pond berms were constructed primarily of sand and other fill material. Coal ash from the power plant operations accumulated in the pond. This practice stopped with the closure of the power plant in the 1980s.

The area was identified as an AOC in the License, issued in June 2003. Numerous studies have been completed in accordance with the requirements of the License for the Former Ash Pond beginning in 2004. Remedial work was completed in 2016 at the Former Ash Pond was reported in the 2016/2017 CAIP. Approximately 148,000 cubic yards of ash and soil were removed and approximately 124,000 cubic yards of clean soil was replaced on site in the constructed wetland. Site restoration incorporated 1,700 ft of riparian restoration, upland meadows, vernal pools, and submergent, emergent, and forested wetlands.

Future plans for the site include moving the perimeter fencing so that the Former Ash Pond area would be outside of the Midland Plant fence line, also making the fence outside of the floodplain. The site is adjacent to a river front property that is owned by the City of Midland. The City is currently planning the restoration of this 14-acre property to a natural area with public access. The restoration design for the Former Ash Pond area incorporated the goals of the City of Midland and other stakeholders for a comprehensive restoration of the entire area, which would provide one mile of riparian restoration along the river and a nearly 45-acre natural area with public access, while also improving the aesthetics of a property that is visible from the downtown area and as you enter the City from the south.

14.1 Overview of Site Characterization and Interim Measures

Studies were completed in accordance with the requirements of the License for the Former Ash Pond beginning in 2004 include:

- RFI Phase-1 Type Investigation/Preliminary Assessment (2004) - A preliminary assessment was completed in 2004 in response to the classification of the Former Ash Pond as an AOC by EGLE, in accordance with the requirements of the 2003 License, Corrective Action Conditions and Schedules of Compliance, Parts XI.C.2 and XII.A.
- Surface Water Protection Monitoring Evaluation (2004) - Five monitoring wells were installed between the Former Ash Pond and the river to evaluate groundwater flow and groundwater quality in 2004. Furthermore, four composite samples of coal ash from the Former Ash Pond area were obtained in October 2004 and analyzed by synthetic precipitation leachate procedure (SPLP) and the toxicity characteristic leachate procedure (TCLP) methods for the following metals: silver, aluminum, arsenic, barium, beryllium, cadmium, cobalt, chromium, copper, iron, manganese, nickel, lead, antimony, selenium, thallium, vanadium, zinc, boron and mercury.
- On-going Groundwater Monitoring - Five monitoring wells installed during the 2004 surface water protection monitoring evaluation (located between the Former Ash Pond and the river) are sampled on a quarterly basis and have been since November 2006, in accordance with the Michigan Operations Act 451 Part 111 Operating License as part of the surface water protection program. The groundwater from these wells is analyzed for a list of primary organic constituents, as well as arsenic and boron.
- Main Plant West Side Shallow Hydrogeologic Study (2009) - The study was conducted under the 2003 License Compliance Schedule H-11. Thirteen monitoring wells were installed in 2009 to the north and west of the Former Ash Pond to evaluate the potential for groundwater to migrate beyond the facility boundary.

- Terrain Conductivity Survey (2013) - In 2013, a terrain conductivity survey was performed using an EM31-MK2 electromagnetic (EM) conductivity device of the areas north and west (along the river) of the Former Ash Pond.
- Terrain Conductivity Survey (2014) – In 2014, a second terrain conductivity survey was conducted inside the berm of the Former Ash Pond.
- Soil and Groundwater Characterization (2015) – Soil and groundwater samples were collected from soil borings and new wells installed within the interior of the Former Ash Pond, the berm around the Former Ash Pond, and in the flats between the Former Ash Pond and the Tittabawassee River.
- Ash Pond Wetland Delineation Report (2015) - A wetland delineation report was completed in October 2015 to delineate wetlands in preparation for anticipated remedial activities including removing coal ash and soil, removing fence and sections of the berm, enhancing wetlands, managing invasive species, and incorporating a trail system. The wetland delineation was completed using procedures set forth in accordance with Part 303, Wetlands Protection, of Act 451 Natural Resources and Environmental Protection Act (NREPA), as amended (1994).
- Ash Pond Remedy Implementation Workplan (2015) – The workplan for the work at the Former Ash Pond including a characterization of the Site, and evaluation of the data against screening criteria, preliminary pathway evaluation, and proposed source removal activities was presented in the annual 2015 Corrective Action Implementation Summary Report and 2016 Workplan (CAIP).
- Ash Pond Remedial Action Report (2016) - A report on the remedial work completed in 2016 at the Former Ash Pond was provided in the 2016/2017 CAIP. While, it had been estimated that approximately 90,000 cubic yards of material would be removed from the site, additional excavation based on verification sampling and removal of visual ash resulted in approximately 148,000 cubic yards of ash and soil being removed in 2016. This material was taken to the City of Midland Landfill, with the exception of 10,000 cubic yards that was taken to Salzburg Landfill.

14.2 Current Status

Routine groundwater monitoring at the site has continued to be performed as specified in the current SAP at the groundwater detection wells (Figure 14-1). Five monitoring wells located between the Former Ash Pond and the river are sampled on a quarterly basis and have been since November 2006, in accordance with License as part of the surface water protection program. The groundwater from these wells is analyzed for a list of primary organic constituents, as well as arsenic and boron. No VOCs have been detected above the reporting limit. Results indicated that boron concentrations are below GSI in all five monitoring wells. Concentrations of arsenic are below GSI in MW-6166, MW-6167, and MW-6168. Arsenic concentrations have exceeded the current generic GSI criteria in MW-6165 and MW-6169 during recent monitoring events.

Due to the arsenic exceedances, Dow has undertaken additional site characterization activities during 2018 and 2019 to refine the CSM and establish an agreed upon regulatory path for closure of this site.

14.2.1 Work in 2019

Work in 2019 focused on completing the CSM revision, sharing information with EGLE and providing briefings regarding overall site characteristics and status, establishing a path forward for site closure with EGLE, and preparing the Part I of the Remedial Action Plan/Closure Report (RAP/CR).

In 2019, Dow continued to finalize the completion of the refinement to the CSM for the Former Ash Pond. The principal tasks of this evaluation consisted of reviewing and interpreting previously-acquired site subsurface lithology data within the context of the depositional environment, applying Environmental

Sequence Stratigraphic (ESS) analysis and developing a groundwater contour map. ESS was utilized in the Ash Pond area to aid in the development of a robust, high-resolution CSM. An objective of the CSM is to use it to help evaluate potential GSI issues related to the former Ash Pond area. More specifically, the objective of the incorporation of ESS in refinement of the Site CSM is to assess the connectivity of transmissive sediments at the Site to better evaluate potential contaminant flow pathways in relation to the nearby Tittabawassee River.

During the May Dow/EGLE Corrective Action Status Meeting, Dow discussed recent work that had been completed for the Former Ash Pond and requested an additional meeting with EGLE to discuss the site in greater detail, present the refined CSM, and ultimately discuss demonstration of GSI compliance at the site. During that subsequent meeting held June 4, 2019 with representatives from Water Resources and Materials Management Division, Dow presented an overview of the site, the refined CSM, and presented potential GSI compliance options that fit the site conditions (Appendix I). Specifically, Dow discussed GSI compliance options such as a mixing zone, site-specific criteria, and de minimis effect demonstration at the meeting that were applicable to site conditions. During the meeting and subsequently, EGLE suggested that the mixing zone request was likely the most viable option to demonstrate GSI compliance.

In an email dated June 19, 2019 EGLE made some additional suggestions regarding potential steps that could be taken to support the mixing zone request and the site closure. Many of these suggestions were then discussed at the subsequent June Dow/EGLE Corrective Action Status Meeting. During the July Dow/EGLE Corrective Action Status Meeting, EGLE requested additional information be submitted so that they could conduct additional site analyses. There was some question regarding the groundwater model and flow regime presented in the refined CSM and EGLE wanted to additional information to be able to better assess the CSM. Dow agreed to provide the information that EGLE requested and posted the boring and well logs on-site, information on backfill material and grading, site data and a screening table on the SharePoint site in August. Dow also prepared a CSM technical memo titled *Ash Pond Conceptual Site Model Development* to provide further information regarding the methodology and data used to prepare the revised CSM and submitted that with the additional information provided to the agency (Appendix J).

In the September Dow/EGLE Corrective Action Status Meeting Dow discussed the plan to move forward with the Former Ash Pond site. Dow discussed the intent to submit the RAP/CR document in three volumes, similar in structure to the Midland Area Soils RAP. For the Former Ash Pond submittal, Part I is the Remedial Investigation Characterization and Assessment (RICA, Part I) for the Former Ash Pond Area. The purpose of this volume is to provide an overview of the site setting, land use, release characterization, and historical investigation activities; identify the potential exposure pathways; and present the methodologies to determine the contaminants of concern for human health and ecological exposure. The Remedy and Screening Criteria Evaluation (RSCE, Part II) presents and summarizes the results of the human health and ecological risk screening evaluations, any constituents of interest (COIs) identified for relevant exposure pathways and details the workplan for remedy. The final CMI, Part III describes the remedial actions and how the remedial actions address current and reasonably anticipated future use, meet the requirements of the Act 451, and ensure the protection of the public health, safety, welfare and the environment.

Dow explained that the intent of this structure was to provide additional information to the agency while allowing Dow and EGLE some flexibility in working out some of the finer details for the final portions of the document. Dow also informed the agency of anticipated timelines for the submittal and detailed that the plan was to move forward with the request for the calculation of mixing zone based GSI criteria. EGLE was supportive of this path forward.

In the October Dow/EGLE Corrective Action Status Meeting, the agency indicated that upon review of the supplemental material provided by Dow, there were additional technical questions raised that they would like to discuss in a subsequent technical meeting for the site. The technical meeting was held at Dow to discuss these concerns on October 28, 2019. One of the primary issues discussed during this meeting was the groundwater flow model presented in the CSM. As a consequence, EGLE requested that Dow collect additional site information including a well inventory, resurvey of the existing wells, and collect a

synoptic water level event. Dow agreed to collect the information and mobilized resources to collect the additional information. The wells were inventoried, resurveyed, and synoptic water level data was collected on November 12, 2019 (Table 14-1). Subsequent to this data collection, in mid-December the agency requested that Dow also install surface water staff gauges and include these measurements with the groundwater data collection. Due to the timing of this request, this additional work could not be scheduled until 2020.

14.3 Path Forward

Work in 2020 will continue to support establishing an acceptable path forward for site closure with EGLE and working towards that end.

During 2019, Dow drafted Part I of the Former Ash Pond RAP/CR. This document will be submitted to the agency in 1st Quarter 2020. Work on Part II is scheduled to begin in 2020. It is anticipated that this volume will be submitted in 2020. Dow also began preparing request for the calculation of mixing zone based GSI criteria in 2019. It is anticipated that the request will be submitted in early 2020. Once the water surface elevation data that EGLE requested in December 2019 has been completed and assessed, Dow and EGLE will schedule a follow-up technical meeting to review this data.

In addition to collecting the water surface elevation data that EGLE requested in December 2019, Dow also plans on additional investigation of the southern portion of the wetland near 6169 (6169 Wetland) and the collection of additional general chemistry information from the compliance wells and surface water.

Work in 2020 is anticipated to be completed in accordance with the milestone schedule presented in Section 17.0. Unless otherwise necessary or requested plans or findings will be provided during periodic progress meetings, which are scheduled to occur on an approximately monthly basis. Annual updates detailing the work completed and projected for the next year will be presented in the annual CAIP.

14.3.1 Seep Investigation and General Chemistry Data Collection

During completion of the wetland construction it was noted that there appears to be a significant continuous water seep coming from the southwest corner of the 6169 Wetland. The seep has been investigated in various ways to determine if it is groundwater or a leak in a nearby watermain. Through these investigations, the current hypothesis is that an old trench in the area may have been filled inadequately creating a conduit for groundwater to flow directly to the bank of the southernmost portion of the 6169 Wetland and feed a significant amount of water directly into the southwest corner.

14.3.1.1 Seep Investigation Methodology

To evaluate the groundwater seepage into the 6169 Wetland a hand-held thermal infrared (TIR) survey will be conducted with a FLIR Model TB660 camera. In addition to thermal images, the camera is equipped with video and normal color camera capabilities, as well as a GPS to locate the position of images obtained during the survey. TIR methods utilize the temperature contrast between groundwater and surface water to visualize groundwater seeps under ideal conditions.

The survey will be completed around the perimeter of the 6169 Wetland and infrared images will be taken systematically along the banks of the wetland to evaluate the groundwater seepage to the wetland from the Site, with particular attention to area in question.

Groundwater temperature typically remains constant year-round, and often is approximated as annual ambient air temperature. Surface water temperature generally equalizes with the ambient air temperature and is subject to diurnal and annual temperature fluctuations. Therefore, utilizing the thermal contrast between groundwater temperature and surface water temperature provides a method of identifying groundwater seepage discharge into a given surface water body. Thermal methods are particularly

successful during the summer and winter months when there is the largest contrast between groundwater and surface water temperatures.

As an initial survey tool, TIR provides for an efficient evaluation in shallow surface water environments. TIR imagery visualizes the electromagnetic radiation emitted by the thermal properties of a body, which can be related to an absolute temperature using Planck's Law. TIR imagery is only representative of the temperature of the surface water at the air/water interface (i.e., "skin" temperature), which can potentially cause masking of the deeper groundwater temperature contrasts, particularly if stream mixing is minimal. The surface water temperature also is generally closer to ambient air temperature than in-situ groundwater temperature due to latent heat interaction.

Through the collection of the relative temperature difference data, using the TIR, relative groundwater seepage fluxes can be distinguished. These differences can be induced by pressure differences or can be a result of differences in the hydraulic conductivity between the stream materials and the adjacent soils. A low seepage flux of groundwater to surface water will result in a groundwater seepage temperature that is more similar to the surface water temperature, while a higher seepage flux will tend to retain a warmer groundwater temperature signature. Therefore, the lower the seepage flux magnitude the more difficult it is to distinguish the groundwater seep from the background surface water.

14.3.1.2 General Chemistry Parameter and Stiff Diagrams

Additional field work in 2020 will include the collection of general chemistry parameters to create Stiff diagrams for the compliance wells and wetland areas. Stiff diagrams are graphical representation of the general chemistry of ground water. A polygonal shape is created from four parallel horizontal axes extending on either side of a vertical axis. Cations are plotted on the left of the vertical axis and anions are plotted on the right (Fetter, 1994). These shapes are unique for a unit or body of water. Stiff diagrams are widely used because they facilitate rapid comparison of water quality from distinctive shapes resulting from changes in general water chemistry. The relatively distinctive diagrams can be used to illustrate ground water composition differences or similarities. One feature is the tendency of a pattern to maintain its characteristic shape as the ground water becomes diluted. It may be possible to trace the same types of ground water contamination from a source by studying the patterns.

15.0 B-SEWER MANHOLE B108 AOC

The B-Sewer MH B108 area of concern (AOC) is located along the 10th Street corridor, south of E Street, and west of the pipe rack near 1385 Building. This AOC was identified during a source area investigation completed in 2018. The DNAPL-impacted area and surrounding high analyte concentration area is estimated to be approximately 37,500 ft² in size. Due to the identification of an area with free product with measurable thickness, a new source discovery notification was sent to EGLE on January 10, 2019 and is now included on Table B2-1. The location of the new AOC is shown in Figure 15-1.

There are currently no complete exposure pathways to any potential receptors as all groundwater at this AOC is captured by RGIS and soil impacts are located more than 5 ft bgs. Furthermore, the DC pathway for surface soil of this area was evaluated in 2018 and the results did not exceed non-residential DCC. Dow is addressing this AOC in line with the obligations outlined for source area reduction under the Corrective Action requirements found in Part XI.U.1-5 of the facility operating license.

15.1 Site History

The B-Sewer system includes multiple sewer legs that are tied together and discharge through MH B100 before discharging to the Michigan Operations (MiOps) WWTP. Sewer samples have been collected from MH B100 since 2008 as part of the National Pollutant Discharge Elimination System (NPDES) Permit Pollution Minimization Program (PMP). Samples continue to be collected from the B-Sewer system because data indicates the system is a potential source of PMP environmental contaminants of interest (COIs).

During a sewer survey conducted in the Fall of 2015, the field team noted elevated PID readings at five MHs (B108, B110, B110A, B111, and B119.06) in the B-Sewer system upstream of MH B100 location (Figure 15-2). The five MHs were sampled in the second quarter of 2016 (2Q 2016). Based on the 2Q 2016 analytical results from samples collected at the five B-Sewer MHs, it was determined that discharges to MH B108 may be a potential source of 2,3,7,8-TCDD concentrations/toxic equivalent concentration (TEC) values, pentachlorobenzene, and hexachlorobenzene to the WWTP. In addition, MH B108 had the highest concentrations of several other VOCs and SVOCs out of the five MHs sampled.

Additional samples were collected quarterly from MH B108 through the remainder of 2016. In the fourth quarter of 2016 (4Q 2016), sampling was extended to include the MHs B108.01, B108.07, and B109, which are directly upstream from MH B108, to determine if one of the sewer legs discharging into MH B108 was the source of the contaminant concentrations observed in B108 or if the source was in media centralized around MH B108. The 4Q 2016 results indicated elevated PMP analyte concentrations in MHs B108.01, B108.07, and B109. In addition to the sampling, a sewer cleaning program was executed in the sewers upstream of MH B108. Findings included debris in the sewers and elevated VOC air monitoring results.

Ultimately, it was concluded that the elevated concentrations seen in MH B100 originated from infiltration into the sewer from the MH B108 area.

15.2 Site Conditions and 2018 Source Area Investigation Findings

As a result of identifying MH B108 as the source of PMP COIs observed at the WWTP, Dow investigated the history and area around MH B108 in 2018 to determine if the soil and groundwater in the surrounding area were contributing to MH B108. The source area investigation field activities completed in 2018 consisted of soil, groundwater, and DNAPL sampling. Twenty-two borings were advanced in a grid like fashion around the MH B108 area to delineate DNAPL impacts in the subsurface. The details of this investigation were summarized in the 2018 CAIP. Analytical data, borings, and well installation logs from this investigation were also included as appendices of the 2018 CAIP.

A review of historical soil boring logs indicated the soils in the general area of MH B108 consist of sand with some vegetation and possible fills that may include debris. These soils are generally found near the surface and extend to a depth of 7 to 14 ft deep. Some descriptions included “discolored medium sand fill,” “discolored sand and cinder fill,” “discolored sand” and “miscellaneous fill”. Below that, the soils are described as a plastic clay or silty clay that would generally be classified as a lakebed clay. Some sands have been observed below the clay/silty clay, but they are generally not described as having an odor or staining. Groundwater depths indicated on the historical borings range from an elevation of 618 to 614 ft North American Vertical Datum (NAVD)29, which generally correlates to be between 5-9 ft bgs depending on the location. Groundwater flow in this area of the facility is generally to the southwest.

The leg of the B-Sewer in this area is installed at a depth where it is beneath the water table and can sometimes intersect the base of the upper sand. As a result, the B-Sewer connected to MH B108 could intercept or collect shallow groundwater and/or possible mobile DNAPL.

The only relevant analytical groundwater data from the area prior to the 2018 investigation was from a sample collected in March 2017 from monitoring well 3337 (see southeast portion of Figure 15-3). This well included elevated concentrations of several potential contaminants of interest, such as o-phenyl phenol, 4-tert-butylphenol, benzene, chlorobenzene, phenol, diphenyl oxide, 1,2,4-TCB, 1,2-DCB, 1,4-DCB, and n-nitrosodiphenylamine.

The general geologic conditions observed in the B-Sewer MH 108 Area during the 2018 investigation aligned with the observations noted in historical boring logs reviewed prior to the investigation. The subsurface consists of a silty, fine grained, medium dense sand from ground surface to a depth of approximately 15 ft bgs, underlain by a clay unit. Groundwater was typically encountered at 5-6 ft bgs with the saturated zone extending from approximately 6 ft bgs to the top of the clay unit (15-20 ft bgs).

The field investigation delineated an area consisting of visible DNAPL of approximately 100 ft x 40 ft in area and a 150 ft x 250 ft area where a DNAPL sheen/high analyte concentrations were observed (Figure 15-3). The main DNAPL area is centered around borings 9253 and 9258. DNAPL impacts were observed in the 1-3 ft of saturated soil located above the underlying clay at the noted borings. The DNAPL impacts observed at 9263 are believed to be associated with another AOC, the Historical Manufacturing Area AOC, located to the south and east of the noted boring. The detected VOC, SVOC, and dioxin/furan results of the DNAPL sample collected from the temporary wells installed at 9258 are respectively shown in Table 15-1 and 15-2. As a separate area of free product was discovered as a result of the source area investigation, a notification of new source discovery was sent to EGLE on January 10, 2019 per the requirements outlined in Part XI.U.1-5 of the facility operating license.

15.3 Results of Bench Scale Study

Based on the findings of the site investigation, a bench-scale study was completed in 2018 to evaluate potential remedial options related to impacted soil and groundwater in the area. The bench scale study focused on in-situ geochemical stabilization (ISGS) to treat impacted site media (i.e., DNAPL-impacted soils) with the proposed ISGS amendment, Provect-GS[®], which is produced/marketed/sold by Provectus Environmental Products (Provectus). The Provect-GS[®] ISGS technology is not a contaminant destruction approach, but rather relies on the primary mechanism of encapsulation/stabilization of DNAPL and residual DNAPL in the subsurface. This remediation approach provides for targeted and long-term stabilization and encapsulation of DNAPLs encountered by the amendment. Additionally, due to significant reductions in soil permeability at the DNAPL-groundwater interface, the dissolved phase flux from the source area is also mitigated. Furthermore, since the technology is permanganate-based, there is some incidental and/or secondary contaminant reduction due to in-situ oxidative processes. This occurs during the formation of the MnO₂ precipitate as the permanganate is consumed (reduced).

Overall, the bench scale study results showed significant hydraulic conductivity decreases and the encapsulation of DNAPL. The bench scale study also showed secondary organic compound destruction as observed in the soil samples analyzed as part of the study. The following summarizes the findings of

the bench-scale study:

- **Soil Permeability Reduction:** Provect-GS[®] formulations successfully induced the primary encapsulation component of the DNAPL stabilization process, resulting in the rapid physiochemical reduction of soil permeability. In the field, as the DNAPL containing aquifer intervals are rapidly sealed and disconnected via in situ injection via displacement (e.g., direct push), the potential for DNAPL transport or migration is expected to be reduced. The permeability generally decreased by more than 100- to 1,000-fold. However, varying the loading and composition of the Provect-GS[®] amendment (i.e., 4.5% and 10% permanganate and/or the addition of 5% organic carbon material) did not significantly change the hydraulic conductivity results in the treated soils.
- **Column Effluent Treatment:** Phenol, substituted phenols, benzene, and substituted benzenes were the dominant compounds observed in the effluent from the columns. The 4.5% and 10% Provect-GS[®] formulations without the organoclay additive reduced the concentrations of phenol and substituted phenols by more than 99% in the aqueous effluents from the column trials. The addition of organoclay to the 4.5% Provect-GS[®] resulted in higher effluent concentrations for these compounds. The concentrations of benzene and substituted benzenes were reduced in aqueous effluents by about 30% with the 4.5% Provect-GS[®] formulations, with and without organoclay, while the with and without organoclay, while the 10% Provect-GS[®] formulation achieved a 10% reduction in concentrations. The overall reduction in the concentration of quantified organic compounds was 97% with 4.5% Provect-GS[®], 62% with 10% Provect-GS[®], and 18% with 4.5% GS with 5%wt organoclay.
- **Column Soil Residuals:** Phenol, substituted phenols, substituted benzenes and phenyls were the dominant compounds observed in the column soil samples. The Provect-GS[®] formulations reduced the concentrations of phenol and substituted phenols by more than 98% in the soil intervals that were permeated with reagents. The 4.5% Provect-GS[®] formulation and the 10% Provect-GS[®] formulation performed equally well, and the addition of organoclay did not significantly improve the concentration reductions of these compounds. The concentrations of the phenyl compounds increased, which may reflect the conversion of the phenols to chemically similar phenyls.
- **Diffusion Trials:** Phenols, substituted phenols, substituted benzenes and phenyls were the dominant compounds observed in the diffusion samples. The results of the trials confirmed that Provect-GS[®] has little effect on the substituted benzene concentrations, but the concentrations of phenol and substituted phenols are significantly reduced. The lack of interaction with the substituted benzenes is reflected by the essentially equal diffusion of these compounds from the treated and untreated samples. The Provect-GS[®] reaction with the DNAPL appears to have reduced the SVOC diffusivity by a factor of about 6 times.

Based on the results of the bench-scale study, it was believed that when the Provect-GS[®] amendment was applied at field-scale, the hydraulic conductivity decreases and encapsulation of the DNAPL in tandem with the secondary contaminant reduction due to oxidation from permanganate reduction will ultimately result in notable reduction in mass flux of contaminant into groundwater and into the B-Sewer. The bench-scale study report authored by ReSolution Partners, LLC is included as Appendix K.

15.4 2019 Pilot Study Design

Based on the results of the bench-scale study, a field-scale pilot study was proposed and implemented in 2019 in the B-Sewer MH B108 AOC. The study was designed to meet the following objectives:

- Confirm field-scale applicability of ISGS to stabilize DNAPL material in the study area.
- Evaluate the field-scale implementation issues.

- Provide an overall proof-of-concept for potential application of this technology in other areas of the facility.
- Demonstrate the ability/efficacy of ISGS amendment to:
 - Provide for comparable hydraulic conductivity and resultant mass flux decreases on a field scale (compared to bench-scale).
 - Provide comparable contaminant concentration decreases on a field scale (compared to bench-scale)
 - Effectively address the entire B-Sewer MH B108 area and resulting impacts.
- Evaluate field scale application methodology for ISGS amendment with respect to injection spacing; ROI; overall ability to implement the technology; and costs related to future full-scale projects.

In preparation for the field-scale pilot study, a Groundwater Discharge Permit Exemption Request was submitted to the MDEQ November 15, 2018 for approval to inject the amendments to be used as part of the field-scale pilot study. MDEQ approved the exemption request on March 1, 2019. The exemption request along with the approval letter are included in Appendix L.

The ISGS field-scale pilot study included a planned pre- and post- treatment performance monitoring program including soil permeability testing (i.e. slug tests) and groundwater and DNAPL (where present) level gauging along with soil, groundwater, and MH/sewer sampling. The schedule shown in Table 15-3 includes a summary of the types of monitoring, and the frequency at which the monitoring was conducted following the completion of the field injections. Slug testing was completed both pre- and post-ISGS injection on monitoring wells installed in the study area to verify the reduction of permeability from the amendment addition. Soil samples were collected both pre- and post-ISGS injection to verify the stabilization of DNAPL and the reduction of organic constituent concentrations. Groundwater from monitoring wells in the study area were also sampled and analyzed for VOCs, SVOCs, metals, and dioxins/furans as well as for general chemistry and field data parameters. Water samples from within MH B108 were also collected and analyzed for VOCs, SVOCs, metals, and dioxins/furans. All analytical lab reports and field forms pertaining to this pilot study can be found in Appendices M and N, respectively.

15.4.1 Pilot Study – Soil

In February 2019, eight borings (9425 through 9432) were advanced via hollow stem augers to approximately 15-20 ft bgs in order to sample and describe the underlying geology. Each boring was advanced to a terminal depth that left the boring slightly advanced into the underlying competent clay/lakebed clay in the area. The boring locations were chosen to establish a monitoring network for the pilot study (Figure 15-4). All borings were continuously sampled for lithological logging via split spoon by a field geologist using the Unified Soil Classification System nomenclature and descriptors, and soil samples were collected based on field observations and PID readings. Field observations noted during the investigation activities consisted of the first encounter of saturated soil, any staining/discoloring, presence/absence of DNAPL, and visual conditions of the soil above and slightly into the underlying clay.

Nine soil samples were collected from six of the borings (9426, 9427, 9428, 9429, 9430, and 9432) advanced in February 2019 (Figure 15-4). Most of the samples were collected from the most impacted interval (located above/immediately within the underlying competent clay/lakebed clay in the area), except for boring 9429 where two additional intervals immediately above the highest impacts were also collected. All soil samples were analyzed for VOCs via 8260B, SVOCs via 8270C, metals via 6020/7471A and dioxins and furans via 1613b. VOC, SVOC, and metals analyses were completed by Test America in North Canton, Ohio. All dioxins/furans analyses were completed by Vista Analytical in El Dorado Hills, California. All wells were gauged prior to the beginning of a sampling event.

In early December 2019, six additional borings were advanced within 1-2 ft of the borings sampled in February 2019. The purpose of these borings was to collect post-treatment soil samples to assess the concentrations of the same analyte groups noted above several months after the injection event completed in April 2019. The borings were also advanced to observe the presence of the mineral crust formed around the DNAPL at the site as a result from its reaction with the injectant. After it is analyzed and fully evaluated during the first two quarters of 2020, the data from these soil samples will be shared with EGLE in one of the monthly Corrective Action meetings in the second quarter of 2020.

15.4.2 Pilot Study – Groundwater

The eight boreholes advanced in February 2019 (9425 through 9432) were completed as monitoring wells. Each monitoring well construction consists of a 5 ft x 2 in diameter 10-slot schedule 40 PVC screen connected to the surface via 5 ft x 2 in diameter schedule 40 PVC risers. For each well, the annular space between the well and the formation was filled with sand to 2 ft above the top of screen, followed by a grout with Barad™ additive to the ground surface. These wells were completed with a flush-mount cover so the placement of injection points was not limited in the future. The eight wells, 9425 through 9432, and a well installed in the area in April 2018 (9289) make up the monitoring network used for this pilot study. The well installation details are presented on the boring logs included in Appendix O.

The wells in the monitoring network were developed in March 2019 prior to the initial baseline groundwater sampling event. Well development was completed with the use of a surge block to surge a given well in its screened interval for several minutes. After the removal of the surge block, a remotely controlled pump was then lowered into the well to where the intake was initially placed near the bottom of the screened interval. The well was then pumped until the observed discharge was clear. While pumping, the positioning of the pump intake would be cycled over the length of the screened interval to further dislodge and remove any solids in the water column.

As part of the performance monitoring program, groundwater samples were collected from these wells in March 2019 (baseline), May 2019 (post-injection monitoring event 1 [PM#1]), June 2019 (PM#2), September 2019 (PM#3), and November 2019 (PM#4). All the results for PM#4 will not be available for this CAIP submittal (specifically the dioxin/furan data). These remaining results will be incorporated in the final assessment of the pilot study to be completed during the first two quarters of 2020. The results will be shared with EGLE during one of the monthly Corrective Action meetings in the second quarter 2020.

For each groundwater sampling event, all nine monitoring wells were sampled via standard low-flow techniques. The samples were sent for analysis for VOCs via 8260B, SVOCs via 8270C, metals via 6020/7470A, and dioxins/furans via 1613b. VOC, SVOC, and metal analyses were completed by Test America in North Canton, OH and the dioxin/furan analysis was completed by Vista Analytical in El Dorado Hills, CA. It is noted that monitoring well 9428 contained DNAPL during each sampling event which limited the volume of water that could be collected for sample analysis. The limited volume of water in tandem with the decreased recharge rate observed in monitoring well 9428 post-injection further limited sample volume; therefore 9428 was not sampled for dioxins and furans for PM#2 through PM#4. All the sampling logs are included in Appendix N. Note, due to equipment being damaged as a result of the ongoing geochemical reaction with the ISGS amendment during PM#1, stabilization readings were not measured for PM#2 through PM#4 to prevent additional damage. For PM#2 through PM#4, the documented stabilization time for PM#1 at each well was used to dictate when a set of readings would be collected prior to sample collection.

Immediately after the ISGS amendment injection event (April 2019), PM#3, and PM#4, four of the nine wells (9427, 9429, 9430, and 9432) were analyzed for permanganate (MnO_4^-) via spectrophotometric ultraviolet absorbance using a Brinkmann PC 950 probe colorimeter fitted with a 525 nanometer (nm) filter by the Dow EAC laboratory. The MnO_4^- analysis was completed for two reasons: 1) to help gauge the distribution and ROI of the ISGS amendment in the subsurface during the injection event, and 2) to assess the persistence of the ISGS amendment during subsequent monitoring events.

In addition to the groundwater sampling events, each of the monitoring wells were subjected to slug tests in March 2019 (baseline), May 2019 (PM#1), and November 2019 (PM#4). Rising and falling head tests with two different sized slugs were performed on all wells for each event except for 9428 during the baseline event and PM#4. During the baseline, only one rising and falling head test were completed on 9428 (with an air slug) due to concerns of equipment interacting with DNAPL in the well, and only one rising and falling head slug test was completed at PM#4 as tests for this well took exceedingly long when compared to the other eight wells tested. An In-Situ, Inc. Level TROLL 700 transducer was used to rapidly log water levels during the test. ASTM International (ASTM) Standard D4044 was used to establish protocol when completing these slug tests. The raw slug test data is included as a CD in Appendix P.

15.4.3 Pilot Study – MH B108

As part of the overall performance monitoring program, MH B108 was sampled for VOCs, SVOCs, and metals during the baseline event, as well as during the post-injection monitoring events. These analyses were completed using the same methods outlined for groundwater and by the same laboratory (Test America in North Canton, OH). Additionally, sample volume was collected for dioxin/furan analysis via 1613b by Vista Analytical in El Dorado Hills, CA for the post-injection sampling events. The PM#4 dioxin/furan analysis for the MH is not yet available but will be included in the final assessment of the pilot study to be completed during the first two quarters of 2020. Results will be shared with EGLE during one of the monthly Corrective Action meetings in the second quarter of 2020.

Dioxin/furan, pentachlorobenzene, and hexachlorobenzene are also sampled for as part of the PMP sampling program at MH B108. Sampling has been completed at MH B108 on a quarterly basis since April 2016 for the PMP program. The PMP samples are 24-hour composites and the samples collected as part of the pilot study are grab samples or composites from less than one hour. These samples are analyzed via a modification of Method 1613b by Vista Analytical in El Dorado Hills, CA. Note that when PMP data is used as a baseline in this assessment an average of all the data collected from 2016 to prior to the injection event will be used. The fourth quarter 2019 PMP data is not available at this time but will be included in the final assessment of the pilot study to be completed during the first two quarters of 2020. Results will be shared with EGLE during one of the monthly Corrective Action meetings in 2020.

Sample volume from the MH B108 was also collected during the week of the ISGS injection event, PM#3, and PM#4 for MnO_4^- analysis. Similar to the groundwater samples for MnO_4^- analysis, the purpose of this analysis on a sewer sample was to see if any MnO_4^- entered the sewer line during or following the ISGS injection event and to track MnO_4^- concentration trends post-injection to assess how much of the ISGS amendment remained during subsequent monitoring events. Permanganate observed in the sewer line during the injection event could imply that the sewer leg in the area is compromised enough to allow for hydraulic communication of the surrounding groundwater and/or DNAPL with the sewer line.

15.4.4 Pilot Study- DNAPL

Monitoring wells 9289 and 9428 both contained DNAPL during the baseline sampling event. During PM#1 through PM#4, monitoring well 9428 was the only well with DNAPL observed and the DNAPL diminished in thickness in monitoring well 9428 over the course of the pilot study. DNAPL samples collected during this pilot study were analyzed for VOCs (Method 8260), SVOCs (Method 625), and dioxins/furans (Method 1613b) by the Dow EAC laboratory. The VOCs and dioxin/furan results for the PM#4 DNAPL are still outstanding but will be included in the completion of this assessment to be completed in the first two quarters of 2020. Results will be shared with EGLE during one of the monthly Corrective Action meetings in the second quarter of 2020.

The DNAPL samples collected during the baseline event completed in March 2019 were also assessed for their viscosity using a rheometer at varying temperatures by the Dow EAC laboratory. A DNAPL sample collected during the PM#4 event was also assessed for its viscosity.

15.4.5 April 2019 Injection Event

From April 9 to 11, 2019 Innovative Environmental Technologies, Inc. (IET) injected 6,600 gallons of 10% Provect-GS® solution at 37 direct push locations advanced in a grid-like manner in the pilot study area (Figure 15-5). The post-injection report developed by IET is included in Appendix P. The ISGS treatment areas were designed to overlay the DNAPL and residual DNAPL area proximal to the B-Sewer legs in the pilot study areas. The “A” injection locations were focused on the DNAPL area outlined by the 2018 source area investigation. The “B” injection locations were intended to target the areas north and south of the DNAPL impacted zone along the B-Sewer legs. Based on the existing geologic conditions (depth to water table, depth and thickness of DNAPL, and depth to underlying clay), the overall target treatment interval for the ISGS amendment was approximately 8-15 ft bgs, which was further sub-divided into two target intervals of roughly 8-10 ft bgs and 13-15 ft bgs.

IET’s injection trailer (USP 7,044,152, May 16, 2006) consisted of two 120-gallon conical tanks capable of maintaining 30% solids as a suspension via lightning mixers, an on-board generator, all stainless steel piping, a 2-inch pneumatic diaphragm pump with an operating pressure of 110 pounds per square inch (psi), and an on-board 25 cubic feet per minute/175 psi gauge (psig) compressor with 120 gallons of air storage. An AMS 9500-VTR unit was used to advance IET’s proprietary injection rods. The injection rods were equipped with retractable injection zone and backflow protection. Compressed air and injectant was delivered to the rods via high pressure stainless steel braided rubber one-inch diameter hoses.

Once the injection rod was advanced to a target depth at a given injection location and unsheathed, compressed air was first injected into the subsurface at approximately 150 psi until a significant pressure drop was observed at the injection pressure vessel. The intent of this step was to open pathways in the subsurface to facilitate flow of the injectant. The 10% Provect-GS® solution was then injected at approximately 30 psi at flow rates between 2-15 gallons per minute (gpm). The injectant was propelled by the same compressed air system used for the pathway development. The “A” injection locations each received roughly 220 gallons of the 10% Provect-GS® solution (with roughly 110 gallons injected at each interval at an injection point) and the “B” injection locations each received roughly 120 gallons of the 10% Provect-GS® solution (with roughly 60 gallons injected at each interval at an injection point). When the injection at the lower interval was complete at a given injection location, the injection screen was pulled up to the upper interval and the compressed air pathway development was repeated again prior to injection of the injectant. After each injection, approximately five gallons of water was injected to clean the injection line of any residual amendment which was then followed by an injection of compressed air at 50 psi to clear the lines of any remedial liquids prior to moving to the next injection location. Prior to removal of the injection point, the point is temporarily capped to allow for the pressurized subsurface to accept the injectants.

The injection volumes for the “A” and “B” injection points were determined by targeting approximately 5% ISGS concentration in the pore volume of the treatment area, assuming a 30% effective porosity. The ROI for the “A” injection points was expected to be 7.8 ft and the ROI for the “B” injection points was expected to be 5.7 ft bgs. The dosage calculations are shown in Appendix L, which was included as an attachment to the groundwater injection permit exemption paperwork.

During the injection event, sample volume was collected from several wells (9427, 9429, 9430, and 9432) and MH B108 to confirm the ROI of the ISGS injections as well as to verify the potential for hydraulic communication between the sewer line and its surrounding environment. Of note, very little surfacing of the injectant occurred, and when it did occur it was primarily located in the southern portion of the “A” grid and the southern “B” section near MH B109 and wells 9429 and 9428 (see Appendix Q for details).

15.5 2019 Pilot Study – Results to Date

Results from the performance monitoring program, including the baseline sampling and post-ISGS injection sampling events that are available to date are included in this assessment. However, again note that much of the PM#4 (November/December) post-ISGS injection sampling and testing results will not be

fully available and analyzed until the first two quarters of 2020. The quarterly sampling of the MH B108 for the PMP monitoring program has also been included where applicable and available.

Note that the dioxin/furan data discussion will be limited to 2,3,7,8-TCDD concentrations and the 2,3,7,8-TCDD TEC values as those are PMP COIs for the MH B108 sampling program.

15.5.1 DNAPL

DNAPL results for VOC and SVOC analytes detected in all samples collected to date from monitoring well 9428 are presented in Tables 15-4 and 15-5 and are depicted in the bar graphs found in Figures 15-6 through 15-12. Note that the bar graphs depicting the VOC and SVOC results were broken up by concentration ranges to aid in the presentation and interpretation of the results. The 2,3,7,8-TCDD concentrations and 2,3,7,8-TCDD TEC values for the DNAPL samples collected from 9428 are presented in Table 15-6 and Figure 15-13. The VOCs and dioxin/furan results for the PM#4 DNAPL are still outstanding but will be included in the finalization of this assessment to be completed in the first two quarters of 2020. Results will be shared with EGLE during one of the monthly Corrective Action meetings in the second quarter of 2020.

All the same VOC and SVOC constituents detected in the DNAPL sample collected from the temporary well installed in boring 9258 during the 2018 source area investigation (Table 15-1) were detected in every DNAPL sample collected from monitoring well 9428 except for 1,2,3,5-tetrachlorobenzene. An additional analyte, 2,4,5-trichlorophenol, was not originally detected in the DNAPL sample collected during the 2018 source area investigation but was detected in the DNAPL samples collected from monitoring well 9428 as part of the pilot study. Pentachlorobenzene was not analyzed for in the DNAPL samples collected but is a PMP COI.

Although monitoring well 9289 contained DNAPL during the baseline event, all the same VOCs and SVOCs were detected in this baseline sample and the 9428 DNAPL pilot study samples. The only additional analyte to be detected in the DNAPL sampled from 9428 was 2-chloronaphthalene (190,000 micrograms per Liter [$\mu\text{g/L}$]); however, it was only detected in the 1-month post-injection sampling event.

As the primary remedial function of ISGS amendment is to sequester and immobilize the DNAPL (i.e., the primary remedial function of ISGS technology is not destructive), the analytical chemistry of the DNAPL was not expected change throughout the pilot study. The VOC, SVOC, 2,3,7,8-TCDD concentrations and 2,3,7,8-TCDD TEC values of the DNAPL in the study area have remained generally consistent throughout the study.

The VOCs and SVOCs shown in Tables 15-4 and 15-5 (and pentachlorobenzene) along with the 2,3,7,8-TCDD concentrations and 2,3,7,8 TCDD TEC values will be the organic analytes/values of focus throughout this assessment when discussing soil, groundwater, and sewer water analytical results. Specifically, the VOCs and SVOCs noted will be referred to as the VOC/SVOC COIs throughout the discussion of the analytical results.

The viscosity analysis completed on the DNAPL sample collected from 9428 during the baseline event and during PM#4 are shown in Figure 15-14. Based on the result of the viscosity testing, the viscosity of the DNAPL from monitoring well 9428 appears to have decreased. This could be because more complex/polar molecules have been reduced to smaller/less polar molecules via the oxidation reaction with MnO_4^- thus smaller molecule size/less polar has decreased the internal friction between molecules allowing the DNAPL to become slightly less viscous over the course of the performance monitoring program.

15.5.2 Soil

The results of the baseline soil samples collected are presented in Tables 15-7 through 15-9. The VOCs

and SVOCs presented in Table 15-7 are the VOC/SVOC COIs outlined in Tables 15-4 and 15-5. Pentachlorobenzene was also included as it is a PMP COI but was not analyzed for the DNAPL samples collected from monitoring well 9428. Two VOC/SVOC COIs were not detected in any of the baseline soil: 1,2,3-TCB and 2,4,5-trichlorophenol. Naphthalene, diphenyl oxide, chlorobenzene, biphenyl, o-phenyl phenol, 2-methylnaphthalene, 1,2,4-TCB, and 1,2,3,4-tetrachlorobenzene were the only VOCs/SVOCs detected in all the baseline soil samples collected. These eight VOC/SVOC compounds were observed at their highest concentrations in the 11-13 ft bgs sample from boring 9429 except for 2-methylnaphthalene (its highest concentration was seen in the 9-11 ft bgs interval). The maximum concentration of the 12 other VOC/SVOCs listed in Table 15-7 were also observed in the 11-13 ft bgs sample from boring 9429 except for naphthalene (9-11 ft bgs from 9429) and phenol (11-13 ft bgs from 9428).

Nine of the eleven metals analyzed for in soil were detected. The two metals not detected in soil were silver and selenium. The results for the detected metals are shown in Table 15-8. Barium, total chromium, copper, lead, and manganese were detected in all soil samples collected. The maximum concentrations for barium, total chromium, copper and manganese (90,000 micrograms per kilogram [$\mu\text{g}/\text{kg}$], 30,000 $\mu\text{g}/\text{kg}$, 21,000 $\mu\text{g}/\text{kg}$, and 370,000 $\mu\text{g}/\text{kg}$, respectively) were all observed in the sample collected from 11-13 ft bgs from boring 9428. The maximum concentration of lead was detected in the duplicate 11-13 ft bgs sample from 9432. Arsenic was detected in all samples collected except the 9-11 ft bgs sample collected from boring 9429 with its highest concentration measured in the 7-9 ft bgs sample collected from the same boring. Cadmium was only detected in the sample collected from 11-13 ft bgs from 9430 (190 $\mu\text{g}/\text{kg}$). Mercury was detected in the sample collected from 11-13 ft bgs at 9428 and the duplicates collected from 9432 with its highest concentration detected in the sample from 11-13 ft bgs at 9428 at 400 $\mu\text{g}/\text{kg}$. Zinc was detected in samples collected from all borings except the three samples collected from 9429, and its highest concentration measured in the duplicate 11-13 ft bgs sample from 9432 (90,000 $\mu\text{g}/\text{kg}$). The highest metal concentrations were observed in the upgradient boring (9432) and the most downgradient borings (9428 and 9429).

The highest 2,3,7,8-TCDD concentrations were observed at 9429 at 11-13 ft bgs (545 ppt) and the lowest 2,3,7,8-TCDD concentrations were observed at 9432 at 11-13 ft bgs (1.08 ppt). The second highest concentration of 2,3,7,8-TCDD was an entire order of magnitude lower at 9427 at 9-11 ft bgs (26.90 ppt). The same trend was observed in the 2,3,7,8-TCDD TEC values. The highest value (5,978 ppt) was observed at 11-13 ft bgs from 9429, the lowest concentration was observed at 11-13 ft bgs at 9432, and the second highest concentration was an entire order of magnitude lower than highest concentration (614 ppt at 9-11 ft bgs at 9427). All results for 2,3,7,8-TCDD and 2,3,7,8-TCDD TEC are shown in Table 15-9.

These soil results show that the highest concentrations for all the analytes detected were observed in two borings located in the southern portion of the study area (9428 and 9429) with the exception of some metals at boring 9432. The area where borings 9428 and 9429 were advanced was included in the southern portion of the ISGS injection grid and is also downgradient of much of the ISGS injection grid. It is expected that metal soil concentrations from the PM#4 sampling event should be like those seen in the baseline sampling event, with the exception of manganese as the main component of the ISGS technology is MnO_4^- .

Based on the bench-scale study, the concentration of phenols and substituted phenols should decrease in the soil; however, the concentration of phenyl compounds may increase due to the conversion of phenols to chemically similar phenyls. Although not tested in the bench-scale, the 2,3,7,8-TCDD concentration/TEC values and metals should also remain constant. As the soil sampling event for PM#4 happened only recently, the soil data from PM#4 will not be available for inclusion in this CAIP submittal but will be assessed during the first two quarters of 2020 and shared during one of the second quarter 2020 monthly Corrective Action meetings between Dow and EGLE.

15.5.3 Groundwater

The following subsections outline the results to date regarding the groundwater analytical results and the hydrogeological findings (hydraulic gradients from gauging and hydraulic conductivities from slug tests).

15.5.3.1 Analytical Findings - Groundwater

The analytical results for the VOC/SVOC COIs in groundwater samples collected from the monitoring well network throughout the pilot study performance monitoring program are presented in Table 15-10 and 15-11. Bar graphs of the Total VOC COI and SVOC COI results are presented in Figure 15-15 through 15-16.

A 17% concentration reduction of total VOC COIs in groundwater was observed when comparing the final sampling event to the baseline event, which is comparable to the results seen in the bench-scale study performed in 2018. Total VOC concentration reductions were observed in monitoring well 9289 (-38%), 9425 (-22%), 9428 (-5%), 9429 (-7%), 9430 (-60%). Total VOC COI concentrations in groundwater also decreased by 87% in upgradient monitoring well 9432; however, three of the six VOC COI compounds included in the Total VOC assessment were ND for much of the pilot study at 9432. Dissolved total VOC COI concentrations have increased at 9426 (23%), 9427 (24%), and 9431 (12%). The concentrations of 1,2,4-TCB have increased (39%), but groundwater concentration decreases were observed for 1,2-DCB (-11%), 1,4-DCB (-13%), benzene (-42%), chlorobenzene (-12%), and toluene (-37%).

Groundwater concentrations of SVOCs conversely have seen a three-fold increase (334%) over the duration of the pilot study. SVOC concentration reductions have been observed in monitoring wells 9289 (-33%), 9425 (-62%), 9430 (-48%) and upgradient monitoring well 9432 (-45%). Again, many of the SVOC COIs were ND for all if not much of the pilot study at 9432. SVOC COI concentrations increased in 9429 (134%), 9431 (175%), 9427 (295%), 9426 (417%), and 9428 (972%). SVOC COIs 1,3-DCB, 1,2,3-TCB, and 4-tert-butylphenol decreased in concentration in groundwater (-12%, -57%, and -20%, respectively), whereas the remaining SVOC COIs increased in dissolved concentrations anywhere from 44% to 2135%. Much of the SVOC COI concentration evaluation is driven by the increases observed in monitoring well 9428 where measurable DNAPL is still present (see Table 15-11).

Groundwater concentrations of 2,3,7,8-TCDD decreased 84% when comparing baseline results to the PM#3 results (Table 15-12) (note that dioxin/furan data from PM#4 are not yet available and will not be included in the 2019 this CAIP but will be available and assessed during the first two quarters of 2020 and subsequently discussed during one of the second quarter 2020 monthly Corrective Action meetings). Dissolved concentrations of 2,3,7,8-TCDD decreased in monitoring wells 9425 (-60%), 9426 (-85%), 9429 (-61%), and 9431 (-53%). Dissolved concentrations of 2,3,7,8-TCDD have increased in monitoring wells 9289 (216%), 9427 (333%), 9430 (339%), and 9432 (69%). Monitoring well 9428 has had DNAPL, which impacted the amount of groundwater that could be collected during PM#2 and PM#3; therefore monitoring well 9428 does not have dioxin/furan results for those events. Note that these decreases are primarily based on sample reporting limits and that 2,3,7,8-TCDD was ND in all wells sampled during the first sampling event except for 9428 (5,500 picograms per liter [pg/L]). Well 9430 saw a large spike in 2,3,7,8-TCDD during PM#1, but concentrations decreased by two orders of magnitude near to the ND RL observed during the baseline event.

The 2,3,7,8-TCDD TEC values showed similar patterns to 2,3,7,8-TCDD when comparing the baseline results to the third post-injection monitoring event. The 2,3,7,8-TCDD TEC value decreased 85% across the entire monitoring network. The same wells saw decreases in 2,3,7,8-TCDD TEC values: 9425 (-70%), 9426 (-69%), 9429 (-86%), 9431 (-50%) including the upgradient well 9432 (-29%). Wells 9428 (1054%), 9427 (113%), and 9430 (267%) all saw increases in the dissolved 2,3,7,8-TCDD TEC values. The 2,3,7,8-TCC TEC value at 9430 also saw a large spike during PM#1 but concentrations decreased by three orders of magnitude to near baseline concentrations PM#2 and PM#3.

Out of the ten metals analyzed for, seven of them were detected at least once in groundwater throughout

the pilot study. The analytical results for those seven metals are shown in Table 15-13. Overall, the total concentration of these seven metals increased slightly during the pilot study (27%) with much of the increase in concentrations being observed at 9429 (150%). Barium and selenium concentrations remain ND seven months post injection, with only minor detections of these metals observed during PM#1 through PM#3. Arsenic concentrations have decreased (-29%) throughout the duration of the study; however, arsenic concentrations rose slightly at 9429 (71%) and 9431 (194%). Zinc (14%), total chromium (47%), lead (210%), and copper concentrations (834%) all increased when comparing PM#4 to the baseline with the greatest increases of lead and copper detected at 9429. Note that zinc was only detected twice throughout the entire pilot study with both detections occurring during PM#4 (54 µg/L at monitoring well 9428 and in the upgradient monitoring well 9432 at 110 µg/L). Since the highest zinc concentration was observed in the upgradient well during PM#4 and was detected at a concentration only slightly above the reporting limit at monitoring well 9428, the increase in zinc concentrations is likely not attributable to the ISGS injection. Although total chromium, copper, and lead were detected more frequently during PM#4 than compared to previous pilot study monitoring events, these detections in most cases only slightly exceed sample reporting limits from previous post-ISGS injection monitoring events except for the 230 µg/L copper detection and 39 µg/L detection of lead at monitoring well 9429 during PM#4. Ultimately, it appears that metal concentrations in groundwater have predominantly remained unchanged through the course of the pilot study.

The ultra violet (UV) absorbance analysis for MnO_4^- was completed to assess the ROI of the injections during the injection event and to also assess the utilization of the ISGS amendment over the course of the pilot study. The samples collected immediately after the injection (April 2019) (Table 15-14 and Figure 15-17) show that the injectant had adequately been distributed in the subsurface with little to no MnO_4^- measured in the upgradient well (9432) and that the MnO_4^- detections observed at 9427, 9429, and 9430 indicate that the injectant had been distributed in the sub-surface with an estimated 15-20 ft ROI. The MnO_4^- results observed during PM#3 and PM#4 show the MnO_4^- in the Provect-GS[®] had been depleted for oxidation of organic compounds in the subsurface.

15.5.3.2 Hydrogeological Findings

The resulting hydraulic conductivities derived from the slug test data using aquifer test interpretation software (AQTESOLV) are shown in Tables 15-15 through 15-17. All hydraulic conductivity evaluations completed in AQTESOLV were done using the Hvorslev (1951) solution. The graphical outputs from AQTESOLV are included in Appendix O. The AQTESOLV files are included on the same compact disk as the raw slug test data in Appendix O. A bar graph showing the hydraulic conductivities is shown in Figure 15-18. Over the duration of the pilot study, hydraulic conductivities in the pilot study area generally decreased one to two orders of magnitude with the some of the greatest decreases observed in monitoring wells installed in the area containing measurable DNAPL in the subsurface (9427, 9428, 9429, 9430).

Using the hydraulic conductivities determined from the baseline, PM#1, and PM#4 slug test results in tandem with the hydraulic gradient (between monitoring wells 9432 and 9430 assuming a west-southwestwardly groundwater flow direction) and available analytical data (specifically total VOC concentrations) from the same events, a mass flux evaluation of total VOCs was completed using the transect line depicted in Figure 15-19. Groundwater contour figures used to determine the hydraulic gradient are included as Figures 15-20 through 15-22. The parameters and assumptions used for this assessment are shown in Tables 15-18 and 15-19. Scientific data mapping software, Surfer[®], was used to krig the hydraulic conductivity and the total VOC concentrations observed in the monitoring well network sampled during the baseline, PM#1, and PM#4 (Figures 15-23 through 15-28 for the resulting contouring of the hydraulic conductivity total VOC). The mass flux calculations are shown in Tables 15-20, 15-21, and 15-22. The bar graph in Figure 15-29 shows a side-by-side comparison of the resulting max flux values along the transect for the baseline, PM#1 and PM#4. Note at the time of this evaluation, the hydraulic conductivity determination from the slug test results for monitoring well 9428 PM#4 was not available. Based on the field observations while completing the final slug test at this well, the assumption was made for this assessment to use the hydraulic conductivity determined for monitoring well 9428 from

PM#1 as a conservative measure when completing the flux evaluation for PM#4. This assessment will be updated in first two quarters of 2020 to include the corrected hydraulic conductivity value for monitoring well 9428.

The mass flux evaluations for baseline and for PM#1 show a decrease of mass flux in the south-central core of the pilot study area in Figure 15-29 (100-140 ft cells), with an increase in max flux values in the northern half (0-90 ft cells) and southern end (150-200 ft cells) of the transect. During PM#4, the south-central mass flux values decreased further and a decrease below baseline values was observed in the southern portion of the transect (150-200 ft cells) and north central distance cells (90 and 80 ft). In the northern portion of the transect, mass flux values decreased when compared to baseline at distance cells 10-30 ft but are still higher than the baseline flux values at distance cells 40-80 ft. The elevated flux values calculated for PM#1 are likely due to the higher hydraulic gradient calculated between monitoring wells 9432 and 9430. Overall, as seen in Figure 15-30, the increase in total VOC flux observed in PM#1 has now decreased to below baseline levels in PM#4 for the entire pilot study area.

These results indicate that the Provect-GS[®] has 1) decreased the hydraulic conductivity of the formation by encapsulating the DNAPL in the pilot study area and 2) due to encapsulation of the DNAPL the dissolving of VOCs in the DNAPL into groundwater in the pilot study area has also occurred (which was also seen in the 17% decrease in total VOCs noted in Section 15.5.3.1).

A similar evaluation will be completed with SVOC, metals, and dioxins/furans data during the first two quarters of 2020 and will be shared via the one of the second quarter 2020 monthly Corrective Action meetings with Dow and EGLE.

15.5.4 MH B108 – Sewer

The VOC/SVOC COI results for the MH B108 sewer samples are shown in Tables 15-23 and 15-24 and Figure 15-31. The 2,3,7,8-TCDD and 2,3,7,8-TCDD TEC concentrations are shown in Table 15-25. Metals detected in the MH B108 samples and their respective concentration for each sampling event are shown in Table 15-26. Note the PMP sampling program at MH B108 entails collecting 24-hour composite samples on a quarterly basis for analysis of dioxin/furans, hexachlorobenzene, and pentachlorobenzene and collected sample volume during the duration of the pilot study; therefore, the PMP analytical results have also been included in this assessment. Note that the fourth quarter of 2019 PMP data and the pilot study PM#4 dioxin/furan data is not available for this assessment. This assessment will be updated in the first two quarters of 2020 with this missing data and will be shared during one of the second quarter monthly Correct Action meetings with Dow and EGLE.

Total VOC/SVOC COI concentrations have decreased in the MH B108 by 73% and 96%, respectively, over the course of the pilot study. Note that these total values are summed based solely on the pilot study performance monitoring data as the fourth quarter PMP results are not yet available. Much of the decrease in the total SVOC COI concentrations can be contributed to the decrease seen in diphenyl oxide, o-phenyl phenol, and biphenyl concentrations. However, SVOC COIs hexachlorobenzene and pentachlorobenzene have decreased when strictly evaluating the pilot study results compared to the baseline (-99% and -98%, respectively), but have increased in concentration (43% and 30%, respectively) as of August 2019 (roughly four months post-injection) when solely evaluating the PMP analytical results compared to the PMP baseline. The differences in these data sets are likely attributable to the different analytical methods used by the pilot study (8270C) and the PMP monitoring program (modified 1613b). Figures 15-32 and 15-33 show both data sets for each of hexachlorobenzene and pentachlorobenzene, respectively.

For 2,3,7,8-TCDD concentrations and 2,3,7,8-TCDD TEC values, results from the pilot study have shown a 93% decrease for each of these concentrations/values, respectively, as of PM#3. Of note, in the quarterly PMP baseline sample results, the first quarter 2018 analytical result is an outlier. If the outlier is removed from the dataset, these decreases drop from 93% to 53% and 37%, respectively. When strictly evaluating the PMP data set, the concentrations for 2,3,7,8-TCDD and the TEC value have increased by

65% and 78%, respectively, as of the August 2019 PMP sampling event. The same baseline point (an average of the PMP results since April 2016-February 2019) has been used when evaluating both the pilot study and PMP data sets. However, it is noted that if the 2Q PMP (May 2019) results and the pilot study PM#1 (May 2019) results are very similar and both data sets have shown a decrease from those respective events going forward. Figures 15-34 and 15-35 show both the PMP and pilot study data sets for 2,3,7,8-TCDD and the TEC values, respectively.

Out of the ten metals, arsenic, barium, total chromium, copper, lead, and zinc had at least one detection throughout the pilot study. Overall, the sum of the detected metal concentrations has decreased throughout the pilot study at MH B108.

During the ISGS amendment injection event, MH B109 (located north of MH B108 near the center of the injection area, Figure 15-2) was opened for visual observation, and it was apparent that injectant had infiltrated the sewer due to the purple color of the water flow. Sample volume was also collected from the MH B108 during the injection event, PM#3, and PM#4 for permanganate absorbance analysis and the results are shown in Table 15-27 and Figure 15-36. Although the PM#4 estimated permanganate concentration is elevated (which is likely due to particulates in the sample, these field observations and results indicate that there is likely a leakage of groundwater from the surrounding area in the B-Sewer leg leading to the MH B108.

15.6 Summary of Pilot Study to Date

With the performance monitoring data received and evaluated to date the ISGS pilot study completed in the MH B108 AOC appears to have attained the objectives listed in Section 15.4. Estimated permanganate concentrations from samples collected immediately following the injection event and during later post-injection monitoring events have demonstrated that an effective ROI was achieved with the ISGS amendment injection grid and the associated volume of the ISGS amendment injected. Further, the decrease in MnO_4^- concentrations over time as it has been utilized for the ISGS reactions with DNAPL at the AOC has been observed. Additionally, very little surfacing occurred during the injection event further indicating it was effectively distributed in the subsurface. Permanganate was also qualitatively observed in the MH immediately north of MH B108 on the same sewer leg (MH B109) during the injection event and semi-quantitatively observed in samples collected from MH B108 throughout the pilot study, indicating that there is a potential for active flux from the surrounding area into the sewer.

Measured hydraulic conductivities in the core of the AOC where much of the ISGS injection work occurred have decreased one to two orders of magnitude, which is consistent with the reductions observed in the previously completed bench scale study. As a result, the mass flux in the area has decreased as well as of the most recent post-injection monitoring event (-32 %, Figure 15-30). The spike in flux of total VOCs observed during PM#1 was likely due to the change in hydraulic gradient from baseline to PM#1 in tandem with any initial disturbance caused by the recently completed injection event. Additionally, the total VOC flux results from PM#4 in the southern portion of the transect will likely decrease once the hydraulic conductivity determination from PM#4 for monitoring well 9428 is complete. However, a similar assessment of the total SVOC, metal, and dioxin/furan data has not been completed as final data sets came in too late in the fourth quarter of 2019 to be included in this CAIP or are still not available as in the case of the dioxins/furans results. However, these assessments will be completed during the second quarter of 2020.

Although the concentrations of VOC COIs, SVOC COIs, and 2,3,7,8-TCDD that make up the DNAPL at the AOC have remained constant throughout the pilot study (see Tables 15-4 through 15-6 and Figures 15-6 through 15-13), dissolved (groundwater and sewer) concentrations of VOC COIs and 2,3,7,8-TCDD have decreased throughout the duration of the pilot study (Figures 15-15, 15-29, 15-32, and 15-33 and Tables 15-10, 15-12, 15-23, and 15-25). Concentrations of SVOC COIs have increased in groundwater (Table 15-11 and Figure 15-16) mainly due to the continued presence of DNAPL in monitoring well 9428, but it appears the flux of total SVOC COIs into the sewer has been decreased based solely on the pilot study performance monitoring data (Table 15-24 and Figure 15-31 through 15-33). This observed

decrease of total SVOC COIs in MH B108 is likely caused by the reduced hydraulic conductivity in the surrounding area. However, when examining the PMP data for hexachlorobenzene and pentachlorobenzene, the concentrations in MH B108 of these compounds spiked after the injection event and have not yet decreased back down to baseline concentrations. The differences between these SVOC data sets could be due to the different analytical methods used as well. The ISGS injection does not appear to have caused metals to dissolve from the soil at the AOC into the groundwater and subsequently flux into the sewer (see Tables 15-8, 15-13, and 15-26). However, much of the PM#4 data (and fourth quarter 2019 PMP data) has yet to come in; therefore the final evaluation of this pilot study will be finalized in the first half of 2020.

15.7 MH B108 AOC Work for 2020

A more detailed assessment of the overall pilot study results including an evaluation of the efficacy of the remedial technology and the potential application of the technology in other source areas of the Midland facility will be pursued in 2020 when the remaining data from this pilot study has become available and fully evaluated and analyzed. Work in 2020 on this AOC is anticipated to include the additional analysis and evaluation of incoming data from PM#4 during the first two quarters of 2020. The full evaluation of the pilot study will be shared in one of the monthly Corrective Action meetings in the second quarter of 2020 and will be summarized in the 2020 CAIP/2021 WP. These details will be included in the schedule presented in Section 17.0.

16.0 OVERLOOK PARK AND 13S

Overlook Park is an approximately 30-foot-tall observation hill located in Section 28 of Midland Township in Midland County, Michigan. Overlook Park was constructed between 1973 and 1975 with funding from the Whiting Foundation. Soils excavated during the construction of the Dow Tertiary Pond were transported to the site to construct the observation hill. In 1975, the soils were seeded with a grass mix. Due to what is believed to be elevated chloride concentrations in the soil, the first grass crop failed. In 1978, a sprinkler system was installed and the site was reseeded. Within the next several years nearly the entire site was able to support a grass crop.

A historic soil boring made near the apex of Overlook Park indicates that the soils used to construct it consist of sand and sandy clay. An asphalt drive provides access to the observation site from Poseyville Road. An asphalt bike path runs along the southeastern and northern portions of Overlook Park. The Park is privately owned by the Midland Area Community Foundation and is situated on a 15.4-acre parcel. The Dow 6-Pond is located northeast of the site and the Dow T-Pond is located east of the site. A wooded area owned by Dow is located south of Overlook Park and a commercial and residential area is located west of the site across Poseyville Road. See Figure 16-1 for a general site location map.

Brine Well 13S is located on both Dow property and private property. The 13S brine well was located directly east of the intersection of Poseyville and Ashby road (Figure 16-1). The 13S remediation area includes the 13S well site, a section of property slightly north of the 13S well site and property to the east and west of Poseyville Road to the north.

In 1956 the Dow salt sludge disposal well number 13S was installed to a depth of 3933 feet below grade. The well was located at what is now the base of Overlook Park observation hill. A spill near Poseyville Road, estimated at 10,000 to 15,000 gallons of calcium chloride brine, was reported to the Mineral Well Unit, Geologic Survey Division, MDNR on April 8, 1980. The report indicated that on April 7, 1980 the brine disposal well 13S pressured up during work on the well. The spilled brine is reported to have run to a storm sewer and then flowed into the river. Well 13S was plugged and abandoned on September 12, 1980.

16.1 Overview of Site Characterization and Interim Measures

In 1988 Brine Site 13S was initially surveyed with EM38 and EM31 electromagnetic (EM) conductivity devices and resistivity methods to identify locations of brine impact. The report generated from the study, titled *Hydrogeologic Investigation of Brine Well and Pipeline Leaks Western and Southwestern Sites Well 13S and Surrounding Area* by Geosphere, Inc., details that in addition to the EM survey and three resistivity soundings, twenty-nine soil borings were advanced.

The EM survey conducted at the site in 1988 revealed elevated conductivity at Overlook Park, near the 13S well site and to the west across Poseyville Road in a low swampy area. A strong linear anomaly also existed to the north along Poseyville Road spanning the area between the No. 6 Brine Pond and Poseyville Road. The 1988 report states that it is likely that most of the brine impact originated from three likely sources, the No. 6 Brine Pond, the soils used to construct Overlook Park, and partially from the operation of the 13S brine well. A tiling system was installed leading from Overlook Park and along Poseyville Road to intercept brine impacted water from the Overlook Park soils, the 13S well site, and the No. 6 Brine Pond. The groundwater collection tile system is located along the north and western portion of the Park, from which collected groundwater was pumped into the Dow 6-Pond. This system was connected to the new Poseyville Road Collection Tile installed in 2014. The Poseyville Road Collection Tile is also in operation on Dow property along the 6-Pond. A small collection tile was installed just north of Ashby Road, which is not currently in operation. East of the Park, a cement bentonite slurry wall isolates the area from Dow's Active Tertiary Pond Surface Impoundment.

In 1989, a report titled *Hydrogeologic Investigation of Brine Well and Pipeline Leaks Western and Southwestern Sites Well 13S and Surrounding Area Addendum* was prepared by Dow detailing further

investigation at the 13S well site, Overlook Park, and the area west of the No. 6 Brine Pond. The report summarizes that the lithology of the area consists of undisturbed natural soils with surficial sand 10 feet in thickness underlain by glacial clay till. Soils consisting of various types of fill from ash to sands to clays were mounded on top of the undisturbed natural soils for landscaping purposes. These soils, especially the soils used to construct Overlook Park, contained high concentrations of brine. The report states that soil chloride concentrations exceeded 20,000 parts per million (ppm) in the entire area between No. 6 Brine Pond and Poseyville Road in the depth interval of 7 to 13 feet. The majority of the brine impact occurs on the surface of the clay till in the surficial sand unit with brine penetration up to 15 to 20 feet into the clay till layer. In certain areas brine has migrated to the west beyond Poseyville Road with concentrations up to 1,000 ppm. Within the clay till are isolated sand units. These clay till sand units act as a conduit to conduct brine impacted water away from the area. Reported chloride concentrations in the till sand units approached 4,000 to 10,000 ppm.

A deep tiling system was installed leading from Overlook Park and along Poseyville Road to intercept brine impacted water from the Overlook Park soils, the 13S well site, and the No. 6 Brine Pond. A shallow tiling system was also installed at a depth of 5 to 6 feet to cover the area of brine impact in the area west of Poseyville Road slightly north of the 13S well site. Saline water was collected in the collection tile sump and returned through a pipeline to the Poseyville Road tile system. Sump concentrations were monitored monthly when weather allowed. A clay monitoring system consisting of 46 EM wells was installed at one point.

The investigation conducted in accordance with the 2003 Operating License Compliance Activity Schedule Task H-1 measured groundwater concentrations exceeding the Generic Residential Drinking Water Criteria for iron, zinc, calcium, manganese, and chloride in the 6158 cluster well located at Overlook Park. Groundwater samples collected downgradient of the 6158 cluster were below the Generic Residential Drinking Water Criteria; however, iron and manganese were detected above the Aesthetic Drinking Water Criteria.

At the location of highest conductivity, the 6158 monitoring well cluster was installed such that the well screens were placed within the Till Sand at 37, 46, and 56 feet below grade. Results of the initial sampling were used to develop a target list for the down gradient wells.

During the study, it was determined that due to the chloride concentrations observed in the 6158 cluster, corrections needed to be made to water levels in those wells for density variation within the till sand (Appendix H). Water levels were measured on June 14, June 29, July 12, and August 18, 2004, and contour maps were produced of the potentiometric surface. These maps are included as Figures 16-2, 16-3, 16-4, and 16-5. The potentiometric surface contour maps suggest groundwater was flowing towards the southeast.

Groundwater was observed to be present under confined artesian conditions throughout the Till Sand. The hydraulic gradient within the Till Sand ranges from 0.006 to 0.024 ft/ft, with an approximate average of 0.013 ft/ft. Using the average measured hydraulic conductivity, and an assumed effective porosity of 30%, groundwater seepage velocity within the Till Sand ranges from 0.108 to 0.401 feet per day (ft/day), with an approximate average of 0.156 ft/day. Vertical hydraulic gradient was estimated from water level measurements at 6158 well cluster. An upward vertical gradient was consistently measured, appearing to increase with depth from an average of 0.036 ft (from 37 ft and 46 ft) to 0.330 ft/ft (from 47 ft to 56 ft).

Review of the geophysical downhole conductivity logging conducted in the study supports the conclusion that the area of most significant impact is near well cluster 6158. Additionally, the readings (spanning approximately fourteen years) suggest the area is very stable, with minimal recorded change over the observed period. Only one boring, 4469, on the eastern perimeter of the site bordering the Tertiary Pond demonstrated a slightly increasing trend in conductivity at the base of the Till Sand from 1988 to 2003.

As part of the 2003 study, Dow also collected groundwater samples from the residential wells screened in the Till Sand along Freeman Drive. The analytical data were comparable to water quality found in the

regional aquifer. Since that time, the properties have been purchased by Dow, and are no longer in residential use.

Due to the proximity and potential for impacts from the Closed Brine Well 13S, additional investigation was conducted at Overlook Park in 2012. The work for this investigation is found detailed in the *Brine Remediation System Investigation Report for Dow Brine Site 13S* (2012). Groundwater samples for chloride analysis were collected from monitoring wells 2805, 6158A, 6158B, 6158C, 6159, 6160, 6161, 6162; from each collection sump at the collection tile west of Poseyville Road; and from purge well 4479 located to the south of Johnston Contracting. A groundwater flow direction was determined for the July groundwater depth measurements and was found to be to the east and southeast at a gradient of 0.009 ft/ft. The maximum chloride concentration detected in groundwater was 92,000 mg/l in 6158C on July 8, 2011. Groundwater chloride concentrations in monitoring wells 6158A, 6158B, and 6158C exceed the Residential Drinking Water Chloride Criterion of 250 mg/l.

The study found that due in part to the fact that the 13S well site lies between the No. 6 Brine Pond and Overlook Park it is believed that Brine Site 13S contributed little to the overall brine impact in the area. Soil conductivity values, groundwater chloride concentrations, and soil chloride concentrations are highest at Overlook Park and adjacent to the No. 6 Brine pond. The Site was then added to the Brine System Quarterly Groundwater Monitoring Program for 2012. Upon receipt of the additional data generated after the first four quarters of groundwater monitoring, Dow will evaluate appropriate remedial options for the Site.

The wells at Overlook Park were sampled and evaluated for groundwater flow direction, depth to groundwater and groundwater chloride concentration throughout 2012 as detailed in *The Brine Remediation System 2012 Annual Monitoring Report: Dow Brine Site 13S* (URS, 2013). The groundwater flow direction was again confirmed to be to the east or southeast throughout the three quarters of groundwater elevation data collection (Figures 16-6, 16-7 and 16-8). Chloride concentrations are shown on Figures 16-9 and 16-10. The groundwater flow direction was easterly in the first quarter and southeast in the third and fourth quarters. Due to the high chloride concentrations in monitoring well 6158A, 6158B and 6158C, the density correction value was calculated for the groundwater elevation. The site was then moved into annual in monitoring in 2013.

Additional contours were generated for water level data collected in the 3rd quarter of 2013 and 1st Quarter of 2015 (Figures 16-11 and 16-12). Both of these additional monitoring events again confirmed the flow direction to be to the east/southeast.

Investigation activities, including installation of additional wells and groundwater sampling, were performed during 2014 and 2015 to provide the basis for Corrective Action groundwater monitoring in this area. The Corrective Action groundwater monitoring is intended to detect migration of contaminated groundwater from Overlook Park and verify that the groundwater collection tile is functioning properly on an on-going basis. Corrective Action groundwater monitoring in this area was deemed necessary to detect possible releases from Overlook Park, an Area of Concern (AOC) listed under Operating License Condition XI.C). As this AOC is not located within the RCRA Facility Boundary but adjacent to it, a proposal to update the monitoring program was provided to DEQ on September 1, 2016 with the submittal of the draft merged *Sampling and Analysis Plan Midland Plant and Salzburg Landfill (SAP)*.

The Overlook Park Groundwater Monitoring Program proposed in the September 2016 SAP revision was not formally adopted into the SAP. A groundwater monitoring was proposed again *Sampling and Analysis Plan Midland Plant and Salzburg Landfill Rev 8A (SAP 8A)*. In February 2019, Dow responded to comments provided by EGLE on the proposed program included as Table 2-T. Throughout 2019 Dow and EGLE have been working to resolve outstanding issues to be able to approve the revision.

16.2 Current Status and Path Forward

During the September Dow/EGLE Corrective Action Status Meeting, EGLE requested an additional briefing on the status of Overlook Park prior to the approval of SAP 8A. The following week on September 25, 2019 Dow arranged a conference call with EGLE to provide a brief site history and discuss any concerns that the agency had with the proposed monitoring program. During the discussion at the meeting the density correction for wells at Overlook Park was discussed as well as the viability of the sentinel well proposed in the current version of the revision. At the request of the EGLE, Dow agreed to remove chemical monitoring from the proposed sentinel the September 13 version of the document. Dow also agreed to review the site history and provide further information in this annual CAIP submittal. As such, Dow has provided a more comprehensive review of the site characterization work and interim measures performed at this site.

Dow also reviewed the recent site data to examine trends in the data collected from the 6158 cluster (Figures 16-13, 16-14, 16-15, and 16-16) and re-examined the proposed sampling program in the Final version of SAP 8A dated September 25, 2019. Historical and recent data support the conclusion that chloride concentrations are stable, if not slightly trending down, and that groundwater flow is consistently to the east/southeast. While these conclusions support program included in the Final version of SAP 8A dated September 25, 2019 the data also support need for the density corrections and direction on how to contour the water levels collected to verify compliance. Dow would like to discuss these findings with EGLE in early 2020.

Work in 2020 is anticipated to be completed in accordance with the milestone schedule presented in Section 17.0. Unless otherwise necessary requested plans or findings will be provided during periodic progress meetings, which are scheduled to occur on an approximately monthly basis. Annual updates detailing the work completed and projected for the next year will be presented in the annual CAIP.

17.0 2020 CONCEPTUAL SCHEDULE

The Corrective Action work as a whole is anticipated to proceed according to the updated Corrective Action Implementation Plan High Level Overview, provided as Figure 1-4. Work on this program during 2020 is anticipated to progress consistent with the timelines provided in Table 17-1 below.

EGLE and Dow have tentatively scheduled monthly Corrective Action working meetings to facilitate discussions on the topics outlined in this Work Plan, review relevant data or findings and revisit the schedule on an on-going basis throughout the year. A SharePoint website was launched in 2016 to track progress, provide data and other electronic deliverables to EGLE, as needed for decision-making and to help EGLE fulfill their oversight function. As additional information becomes available, other corrective action goals may be identified in cooperation with EGLE.

The anticipated timelines provided below are guidelines to be used for planning purposes only. They are highly dependent on weather, technical developments, and other issues which may necessitate changes. Work scheduling and the planning process, described in Appendix G of Attachment 19 to the current Operating License, will be an iterative process that will incorporate changes, as warranted, through adaptive management.

Unless otherwise necessary or requested, plans or findings will be provided to EGLE during periodic progress meetings, which are scheduled to occur on an approximately monthly basis. Presentations and notes from those meetings will be posted to the Microsoft SharePoint® website approximately two weeks after the meeting. Environmental data collected will continue to be provided each quarter through the Environmental Monitoring Report unless otherwise agreed upon or requested.

Table 17-1. 2020 Corrective Action Workplan Anticipated Milestone Schedule

Report Section	Program	Milestones	Anticipated 2020 Timeline
5	VI	Present and provide a Summary of Initial Zone 3 Phase 2 Sub-slab, Indoor Air and Outdoor Air Sampling Results to EGLE	Q1
5	VI	Collect Seasonal Confirmation Samples and IM Samples for Selected Buildings in Z1, Z2, and Z3 Phase 1, Z3 Phase 2	Q1-Q4
5	VI	Review Zone 3 Phase 3 Building Categorization and Prioritization for Vapor Intrusion with EGLE	Q2
5	VI	Conduct Zone 3 Phase 3 VI Sampling	Q3 and Q4
6	DC	Review Fall 2019 Additional Sampling Results with EGLE	Q1
6	DC	Submit As-Built Drawings for 2018/2019 Implemented DC IMs	Q1
6	DC	Complete Construction of Long-Term Barriers at DC DUs 2D, 1S4, and 1G	Q2
6	DC	Submit Plans for Long Term Barriers at DC DUs 1A-10 and 1A-11; 1O1; 1Q; 5C2; 5KK	Q2
6	DC	Complete Construction for Long Term Barriers at DC DUs 1A-10 and 1A-11; 1O1; 1Q; 5C2; 5KK	Q3
6	DC	Provide Soil Sampling and Laboratory Testing Protocol Memorandum for EGLE Review for Testing of Former Fire Training Area (Zone 1 DU 1D-1)	Q3
6	DC	Prepare Soil Sampling Plans (maps of each DU and increment locations) for Zone 5	Q2
6	DC	Collect Soil Samples for Zone 5 and Additional 2020 sample areas	Q2 and Q3
6	DC	Review results of Zone 5 Direct Contact Soil Sampling with EGLE	Q4
7	Ambient Air	Complete Ambient Air Pathway Evaluation for Zone 5	Q4
8	SDF	Complete design plans for Cell 1 upgrade	Q3
8	SDF	Assess groundwater elevation change at 3916	Q3
9	PLF	Collect Additional Samples from wells 2549, 5924, and 5923	Q1-Q4

**Table 17-1. 2020 Corrective Action Workplan Anticipated Milestone Schedule
(Continued)**

Report Section	Program	Milestones	Anticipated 2020 Timeline
9	PLF	Complete plume modeling and adjust Pump Rate in Purge Wells 2690A and 2917 as necessary for Pilot Optimization	Q1-Q4
10	NEP	Complete high-resolution CSM	Q1-Q2
10	NEP	Finalize field workplan for data gap assessment	Q2
10	NEP	Implement data gap workplan	Q3
10	NEP	Initiate bench studies for remedial technologies as appropriate	Q3
10	NEP	Modify well network optimization plan	Q4
11	CD3	Complete bimonthly sampling program	Q1 - Q4
12	7th Street	Continue to monitor wells 9472, 9273, and 9274	Q1-Q4
13	Mark Putnam AOC	Assessment of additional 2019 data and gap analysis	Q2
13	Mark Putnam AOC	Further delineation fieldwork	Q3
13	Mark Putnam AOC	Alternative assessment for management approach	Q4
14	Former Ash Pond AOC	Complete additional gauging and water level data collection	Q1
14	Former Ash Pond AOC	Request for Mixing Zone Application	Q1
14	Former Ash Pond AOC	Submit Part I of the RAP/CR	Q1
14	Former Ash Pond	Conduct FLIR Investigation and collect general chemistry data	Q2
14	Former Ash Pond AOC	Submit Part II of the RAP/CR	Q3
15	B-Sewer B108 AOC	Complete evaluation of the Pilot Study	Q2
16	Overlook Park	Discuss SAP Changes	Q1
ALL	ALL	Submittal of 2020 Corrective Action Summary Report and 2021 Corrective Action Implementation Work Plan	Q1 2021

18.0 REFERENCES

AECOM Technical Services, Inc. (AECOM). To be Developed. 2020 Corrective Action Implementation Summary Report and 2021 Work Plan, The Dow Chemical Company, Midland Plant, EPA ID: MID 000 724 724.

AECOM. January 2020. Summary of Investigative Findings. The Dow Chemical Company, Midland Plant, EPA ID: MID 000 724 724.

AECOM. October 2019. Summary of Investigative Findings. The Dow Chemical Company, Midland Plant, EPA ID: MID 000 724 724.

AECOM. July 2019. Summary of Investigative Findings. The Dow Chemical Company, Midland Plant, EPA ID: MID 000 724 724.

AECOM. June 2019. Summary of Investigative Findings. The Dow Chemical Company, Midland Plant, EPA ID: MID 000 724 724.

AECOM. January 2019. 2018 Corrective Action Implementation Summary Report and 2019 Work Plan, The Dow Chemical Company, Midland Plant, EPA ID: MID 000 724 724. January 11.

AECOM, November, 2018. Groundwater Discharge Permit Exemption Request submitted to the MDEQ. November 15.

AECOM. August 2018. 2018 Vapor Intrusion Rescreen of Zone 1 and 2 Phase 1 Buildings, The Dow Chemical Company, Midland Plant, EPA ID: MID 000 724 724. August 1.

AECOM. August 2018. 2018 Revised Vapor Intrusion Workplan, The Dow Chemical Company, Midland Plant, EPA ID: MID 000 724 724. August 24.

AECOM, 2017. 2017 Corrective Action Implementation Summary Report and 2018 Work Plan, The Dow Chemical Company, Midland Plant, EPA ID; MID 000 724 724.

AECOM, December 2015. 2016 Corrective Action Implementation Workplan, The Dow Chemical Company, Midland Plant, EPA ID; MID 000 724 724. December 30.

AECOM, August, 2009. Compliance Schedule Task H-11 West Side Shallow Groundwater Investigation Summary Report. August 7.

Eklund, B., J. Milose, L. DeGrazia, C. Ricondo, and H. Artz-Patton (Eklund et al), March 2019. VI Attenuation Factors and Seasonal Variability at Large Industrial Buildings. Association for Environmental Health and Sciences Foundation (AEHS) 29th Annual Conference, San Diego, CA. March 20.

Eklund, B. and Burrows, D, 2009. Prediction of Indoor Air Quality from Soil-Gas Data at Industrial Buildings. Ground Water Monitoring & Remediation Volume 29, Issue 1, Winter 2009, pages 118-125.

Eklund, B. and V. Kremesec. Recommended Practices Manual for Decision Making in Vapor Intrusion Evaluation. Atlantic Richfield Company, A BP-Affiliated Company. September 4, 2006.

Engineer Research and Development Center (ERDC)/Cold Regions Research and Engineering Laboratory (CRREL). 2013. Demonstration of Incremental Sampling Methodology for Soil Containing Metallic Residues. ERDC TR-13-9. Project ER-0918. September 2013.

ERDC. 2013. Incremental Sampling Methodology (ISM) for Metallic Residues. TR-13-5. Project ER-0918. August 2013.

ERDC/CRREL. 2009. Validation of Sampling Protocol and Promulgation of Method Modifications for the Characterization of Energetic Residues on Military Testing and Training Ranges. ERDC/CRREL TR-09-6. June 2009.

U.S. Environmental Protection Agency (EPA), 2016. Regional Screening Levels (RSLs) - Generic Tables (May 2016). <https://www.epa.gov/risk/regional-screening-levels-rsls-generic-tables-may-2016>. Accessed May 2016.

EPA. 2012. EPA Federal Facilities Forum Issue Paper: Site Characterization for Munitions Constituents. Solid Waste and Emergency Response (5203P). EPA-505-S-11-001. January 2012.

EPA, January 1999. Air Method, Toxic Organics-15 (TO-15). Compendium of Methods for the Determination of Toxic Organic Compounds in Ambient Air, 2nd Edition. Determination of Volatile Organic Compounds (VOCs) in Air Collected in Specially- Prepared Canisters and Analyzed by Gas Chromatography/Mass Spectrometry (GC/MS). EPA/625/R-96-010b.

EPA. December 1996a. Method 8270C (SW-846): Semivolatile Organic Compounds by Gas Chromatography/Mass Spectrometry (GC/MS). Revision 3.

EPA. December 1996b. Method 8260B (SW-846): Volatile Organic Compounds by Gas Chromatography/Mass Spectrometry (GC/MS), Revision 2.

Fetter, C.W. 1994. Applied Hydrogeology. Third Edition. Macmillan College Publishing Company. New York, New York.

Hewitt, A. D., T. F. Jenkins, and C. L. Grant. 1995. "Collection, Handling, and Storage: Keys to Improved Data Quality for Volatile Organic Compounds in Soil," American Environmental Laboratory 7: 25-28.

Howard, C. and R. Corsi. 1998. Volatilization of Chemicals from Drinking Water to Indoor Air: The Role of Residential Washing Machines. J. Air & Waste Manage. Assoc., Vol. 48, pp907-914.

Howard, C. and R. Corsi. 1996. Volatilization of Chemicals from Drinking Water to Indoor Air: Role of the Kitchen Sink. J. Air & Waste Manage. Assoc., Vol. 46, pp830-837.

Hvorslev, M.J., 1951. Time Lag and Soil Permeability in Ground-water Observations, Bull. No. 36, Waterways Exper. Sta. Corps of Engrs, U.S. Army, Vicksburg, Mississippi, pp. 1-50.

Interstate Technology & Regulatory Council (ITRC), 2012. Incremental Sampling Methodology. ISM-1. Washington, DC.: Interstate Technology & Regulatory Council, Incremental Sampling Methodology Team. www.itrcweb.org/ism-1/.

Jenkins, Thomas F., Alan D. Hewitt, Marianne E. Walsh, Thomas A. Ranney, Charles A. Ramsey, Clarence L. Grant, Kevin L. Bjella. 2005. "Representative Sampling for Energetic Compounds at Military Training Ranges." Environmental Forensics 6:45-55.

McKone, T.E. 1987. Human Exposure to Volatile Organic Compounds in Household Tap Water: The indoor Inhalation Pathway. Environ. Sci. Technol., Vol 21, pp1194-1201.

Michigan Department of Environmental Quality (MDEQ), April 2018a. Table 1. Residential and Nonresidential acceptable air concentrations (AACs). The following are AACs that are used as inputs into calculations for generating Volatilization to Indoor Air Criteria (VIAC).

MDEQ, April 2018b. Table 3. Nonresidential VIAC adjusted for 12-hour work-day exposure. Restricted site-specific criteria that apply to a nonresidential structure (< 50,000 ft²) with a slab-on-grade, the depth

to groundwater submitted for this site (i.e. 5 ft), and U.S. Department of Agriculture (USDA) soil type of sand.

MDEQ, April 2018c. Table 4. Nonresidential VIAC adjusted for 12-hour work-day exposure. Restricted site-specific criteria that apply to a nonresidential structure (> 50,000 ft²) with a slab-on-grade, the depth to groundwater submitted for this site (i.e. 5 ft), and USDA soil type of sand.

MDEQ, August 2017. Media-Specific Volatilization to Indoor Air Interim Action Screening Levels.

MDEQ, 2015. *2015 Operation and Maintenance Inspection Report for the Sludge Dewatering Facility (SDF)*.

MDEQ, November 2015. *Response to 2015 Operation and Maintenance Inspection Report. November 19*.

MDEQ. December 2013. Cleanup Criteria Requirements for Response Activity (Formerly Part 201 Generic Cleanup Criteria and Screening Levels, http://www.michigan.gov/deq/0,4561,7-135-3311_4109-251790--,00.html).

MDEQ. May 2013. Guidance Document for Vapor Intrusion Pathway, http://www.michigan.gov/deq/0,4561,7-135-3311_4109_66336--,00.html.

Michigan Natural Resources and Environmental Protection Act (NREPA) May 24, 1995 (Act 451 of 1994), Section 324.20120a

Mueller, J. and Scalzi, M., 2014. In Situ NAPL Stabilization for Flux Reduction. FMC Environmental Solutions and Innovative Environmental Technologies, Inc. (IET) Poster presentation.

Mueller, J et. al., May 2010. In-Situ Geochemical Stabilization (ISGS) for NAPL Management. Adventus Americas, Inc., GeoTrans, Inc., University of New Brunswick, Beazer East Inc. Session Presentation of Battelle's Seventh International Conference – Remediation of Chlorinated and Recalcitrant Compounds.

Mueller, J, J. Moreno, M. Dingens, and P. Vella, March 2007. Stabilizing the NAPL Threat: In-Situ Biogeochemical Stabilization and Flux Reduction Using Catalyzed Permanganate. Adventus Group and Carus Chemical Corp. Pollution Engineering Magazine.

Mueller, J. et. al., June 2003. In-Situ Biogeochemical Stabilization of Creosote/Pentachlorophenol NAPLs using Permanganate. In Situ and On-Site Bioremediation Symposium, Orlando, FL.

Mueller, J., M. Tischuk, and M. Brouman., December 2002. In situ biogeochemical stabilization for Source Area Management." 32 Annual Meeting Israel Society for Ecology and Environmental Quality Sciences, Tel Aviv, Israel.

Naval Facilities Engineering Command (NAVFAC) P-418 Dewatering and Groundwater Control, Department of the Navy, November 1983

Tittabawassee and Saginaw River Team, June 2015. *Tittabawassee River Floodplain General Design and Implementation Work Plan (Rev 1)*.

U.S. Army Corps of Engineers (USACE). 2009. Implementation of Incremental Sampling (IS) of Soil for the Military Munitions Response Program. Interim Guidance 09-02. 20 July 2009.

U.S. Department of Labor Occupational Safety & Health Administration (OSHA), March 2014. Hazard Communication: Steps to an Effective Hazard Communication Program for Employers That Use Hazardous Chemicals Fact Sheet. <https://www.osha.gov/Publications/OSHA3696.pdf>.

Van den Berg et al: The 2005 World Health Organization Re-evaluation of Human and Mammalian Toxic Equivalency Factors for Dioxins and Dioxin-like Compounds, ToxSci Advance Access, 7 July 2006.

