

**FORM EQP 5111 ATTACHMENT TEMPLATE A11
CLOSURE AND POSTCLOSURE CARE PLANS**

This document is an attachment to the Michigan Department of Environment, Great Lakes, and Energy's (EGLE) *Instructions for Completing Form EQP 5111, Operating License Application Form for Hazardous Waste Treatment, Storage, and Disposal Facilities*. See Form EQP 5111 for details on how to use this attachment.

The administrative rules promulgated pursuant to Part 111, Hazardous Waste Management, of Michigan's Natural Resources and Environmental Protection Act, 1994 PA 451, as amended, (Act 451), R 299.9613 and Title 40 of the Code of Federal Regulations (CFR), Part 264, Subpart G, establishes requirements for the closure and, if necessary, postclosure care of hazardous waste management facilities. All references to 40 CFR citations specified herein are adopted by reference in R 299.11003. This license application template addresses requirements for the proper closure and, if necessary, postclosure care of the hazardous waste management units and the hazardous waste management facility for the Dow Michigan Operations Midland Plant & Salzburg Landfill facilities in Midland, Michigan. The information provided in this template was used to prepare the closure and postclosure care cost estimate provided in Template A12, "Closure and Postclosure Care Cost Estimates."

This template is organized as follows:

- A11.A CLOSURE PLAN
 - A11.A.1 Closure Performance Standard
 - A11.A.2 Unit-Specific Information
 - Table A11.A.1 Hazardous Waste Management Unit Information
 - A11.A.3 Schedule of Final Facility Closure
 - A11.A.4 Notification and Time Allowed for Closure
 - A11.A.4(a) Extensions for Closure Time
 - A11.A.5 Unit-Specific Closure Procedures
 - A11.A.5(a) Closure of Container Storage Areas
 - A11.A.5(b) Closure of Tank Systems
 - A11.A.5(c) Closure of Surface Impoundments
 - A11.A.5(d) Closure of Waste Piles
 - A11.A.5(e) Closure of Landfills
 - A11.A.5(f) Closure of Incinerators
 - A11.A.5(g) Closure of Miscellaneous Units
 - A11.A.5(h) Closure of Boilers and Industrial Furnaces
 - A11.A.5(i) Other Closure Activities
 - A11.A.6 Certification of Closure
 - A11.A.7 Postclosure Notices Filed
- A11.B POSTCLOSURE CARE PLAN
 - A11.B.1 Applicability
 - A11.B.2 Postclosure Care Objectives
 - A11.B.3 Postclosure Care Period Point of Contact
 - A11.B.4 Postclosure Care Activities
 - Table A11.B.1 Postclosure Monitoring and Maintenance
 - A11.B.5 Postclosure Care Plan Amendment
 - A11.B.6 Certification of Postclosure

A11.A CLOSURE PLAN

A11.A.1 Closure Performance Standard [R 299.9613 and 40 CFR §264.111]

This Closure Plan is designed to ensure that the facility will be closed in a manner that achieves the following:

- a. Minimizes the need for further maintenance; and
- b. Controls, minimizes, or eliminates, to the extent necessary to protect human health and the environment, postclosure escape of hazardous wastes, hazardous constituents, leachate, contaminated runoff, or hazardous waste decomposition byproducts to the groundwater, surface water, or atmosphere; and, as applicable
- c. Complies with the unit-specific closure requirements for each of the following units:

(Check as appropriate)

- | | |
|---|---------------------------------------|
| <input checked="" type="checkbox"/> Use and management of containers | R 299.9614 and 40 CFR §264.178 |
| <input checked="" type="checkbox"/> Tank systems | R 299.9615 and 40 CFR §264.197 |
| <input checked="" type="checkbox"/> Surface impoundments | R 299.9616 and 40 CFR §264.228 |
| <input type="checkbox"/> Waste piles | R 299.9617 and 40 CFR §264.258 |
| <input type="checkbox"/> Land treatment ^a | R 299.9618 and 40 CFR §264.280 |
| <input checked="" type="checkbox"/> Landfill | R 299.9619 and 40 CFR §264.310 |
| <input checked="" type="checkbox"/> Incinerators | R 299.9620 and 40 CFR §264.351 |
| <input type="checkbox"/> Drip pads ^b | R 299.9621 and 40 CFR §264.575 |
| <input type="checkbox"/> Miscellaneous units | R 299.9623 and 40 CFR §§264.601-603 |
| <input type="checkbox"/> Hazardous waste munitions and explosive storage ^b | R 299.9637 and 40 CFR §264.1202 |
| <input type="checkbox"/> Boilers and industrial furnaces | R 299.9808 and 40 CFR §266.102(e)(11) |

^a Not included in the template

^b *Not yet included in 40 CFR §264.111; therefore not considered*

This Closure and Postclosure Care Plan is for the Dow Michigan Operations Midland Plant & Salzburg Landfill licensed hazardous waste management facilities, which will be referred to as Dow Michigan Operations facility or as the individual facilities. This plan identifies all steps necessary to close each hazardous waste management unit at this facility at the end of its active life and manage the unit during the postclosure care period. Unit-specific closure procedures are discussed in Section A11.A.5 of this template for each unit type indicated above.

It is anticipated that clean closure of some of the units located within the footprint of the 1925 Landfill WMU may not be practical. Closure information for the Staging Pile/CAMU is documented with the design information for those units, located in Appendix C of Attachment XIV.B2, Corrective Action, of this operating license reapplication.

A11.A.2 Unit-Specific Information
 [R 299.9613 and 40 CFR §§264.112(b)(3) and (6)]

Table A11.A.1 Hazardous Waste Management Units Information

The following table identifies each hazardous waste management unit at the Dow Michigan Operations facility subject to the closure requirements of this hazardous waste management facility operating license. The table also includes: each unit's maximum licensed hazardous waste inventory, a list of the waste codes managed in the unit, the anticipated date of closure (if known), and the estimated duration of closure activities once closure begins. Unit-specific methods for closure and detailed schedules are discussed in Section 11A.5 of this template.

Unit Designation	Maximum Inventory (Include Units)	Waste Codes of Hazardous Wastes Managed	Scheduled Closure Date	Estimated Duration of Closure
Container Storage Areas				
Waste Storage Area I (WSA I)	443,685 gallons	Attachment XIV.A2, Appendix A	Not anticipated prior to expiration of operating license	180 days
32 Building Container Storage Area (32 Pack Room) ¹	133,250 gallons			180 days
830 Building Container Storage Area (830 Building) ¹	125,000 gallons of which no more than 100,000 may be liquid waste			180 days
Offload Spots at the Incinerator ¹	48,500 gallons			180 days
703 Tank Farm Spots ¹	50,250 gallons			180 days
Rail Car Spots ¹	38,000 gallons			180 days

¹Closure may coincide with the 32 Building Incinerator closure and may be managed as ancillary equipment.

Unit Designation	Maximum Inventory (Include Units)	Waste Codes of Hazardous Wastes Managed	Scheduled Closure Date	Estimated Duration of Closure
Tank Systems				
1163 Building	360,000 gallons (1,800 cubic yards)	Attachment XIV.A2, Appendix A	Not anticipated prior to expiration of operating license	180 days
33 Building	181,800 gallons (900 cubic yards)			180 days
V-301	18,700 gallons			180 days
V-302	18,700 gallons			180 days
V-303	18,700 gallons			180 days
V-401	18,700 gallons			180 days
V-402	15,900 gallons			180 days
V-403	18,700 gallons			180 days
V-404	18,700 gallons			180 days
V-101	10,150 gallons			180 days
V-601	7,000 gallons			180 days
V-701	7,000 gallons			180 days
Surface Impoundments				
Tertiary Pond	783,000,000 gallons	Attachment XIV.A2, Appendix A	Not anticipated prior to expiration of operating license	1095 days
Incinerator Complex				
32 Building Incinerator		Attachment XIV.A2, Appendix A	Not anticipated prior to expiration of operating license	800 days

¹Closure may coincide with the 32 Building Incinerator closure and may be managed as ancillary equipment.

Unit Designation	Maximum Inventory (Include Units)	Waste Codes of Hazardous Wastes Managed	Scheduled Closure Date	Estimated Duration of Closure
Salzburg Landfill	3,090,000 cubic yards	Attachment XIV.A2, Appendix A	Not anticipated prior to expiration of operating license	180 Days

A11.A.3 Schedule of Final Facility Closure
 [R 299.9613 and 40 CFR §264.112(b)(6)]

The Dow Michigan Operations facility:

(Check as appropriate)

- Anticipates completing final closure of the entire facility by insert estimated date
- Has not determined when the facility will close and does not anticipate completing final closure of the entire facility prior to expiration of the facility's hazardous waste operating license.

Detailed Closure Schedule for Facility Closure: A detailed breakdown showing the closure schedule with the anticipated time of completion for each activity is provided in Appendix A11-2.

A11.A.4 Notification and Time Allowed for Closure
 [R 299.9613 and 40 CFR §§264.112(d)(2) and 264.113(a) and (b)]

The Director will be notified by Dow Michigan Operations & Salzburg Landfill facilities 60 days before final closure of either or both facilities begins. Except as specified in Section A11.A.4(a), final closure activities will be initiated within 90 days of receipt of the final volume of hazardous wastes and completed within 180 days of receipt of the final volume of waste. The tasks and estimated time required for closure shall follow the schedule specified in Section 11A.3. Final closure will be certified by both The Dow Chemical Company and an independent, qualified, registered professional engineer of the state of Michigan.

A11.A.4(a) Extensions for Closure Time
 [R 299.9613 and 40 CFR §264.113(a) and (b)]

For the 32 Building Incinerator and ancillary equipment, stored bulk liquid and solids and containerized waste will be removed within 90 days of receiving the final volumes of hazardous wastes. Due to the complex nature of the work and limited space around the various units of the incineration complex, an extension of the closure period beyond 180 days will be requested at the time of closure, in accordance with the requirements of 40 CFR §264.113(a) for cleaning and demolition of the facility. There is a need to provide isolation of decontamination activities, and certain operations must be planned in sequence rather than concurrently.

Considering the closure methods described in Section A11.A.5(c) for closure of the Tertiary Pond, a significant extension of the closure schedule will be requested at the time of closure, in accordance with the requirements of 40 CFR §264.113(a)

In the event that an extension for closure for the facility or any unit is necessary, the Dow Michigan Operations facility will request an extension in accordance with the requirements of 40 CFR §264.113(a).

A11.A.5 Unit-Specific Closure Procedures

Unit-specific closure procedures are provided for each unit identified in Section A11.A.2 of this template.

A11.A.5(a) Closure of Container Storage Areas [R 299.9614 and 40 CFR §264.178]

This section describes the procedures for closure of Waste Storage Area I (WSA I), 32 Building Container Storage Area (32 Pack Room), 830 Building Container Storage Area (830 Building), Offload Spots at the Incinerator, 703 Tank Farm Spots, and Rail Car Spots located at the Dow Michigan Operations facility. When closure of these units actually occurs at this facility, Dow will prepare a detailed plan including engineering designs and procedures to implement the closure activities for the container storage areas to comply with Part 111 of Act 451, or applicable regulations at the actual time of closure. There are no container storage area located at the Salzburg Landfill facility.

The general closure requirement and specific closure procedures are discussed below. The proposed closure schedule is depicted in Appendix A11-1 of this Attachment.

A. General Closure Requirement

Prior to closure of a container storage unit, it will stop accepting waste. At closure, all hazardous waste and hazardous waste residues will be removed from the containment system. Remaining containers, liners, bases, and soil containing or contaminated with hazardous waste or hazardous waste residues will be decontaminated or removed.

B. Specific Closure Procedures

Specific procedures for inventory management, unit inspection, decontamination, sampling and analysis, and additional waste management are discussed below.

1. Inventory and Remedial Waste Management Procedures

All hazardous waste remaining in the container storage area will be removed for transport to an appropriately licensed treatment or storage facility.

2. Unit Inspection Procedures

After removal of all containerized waste, the walls and floors of the unit will be visually inspected for any signs of contamination by hazardous waste or hazardous waste constituents.

3. Decontamination Procedures

Container storage areas will be cleaned by scraping, shoveling, or power washing to remove any residues of spillage. If any associated structure is to be abandoned, it will be demolished. Demolished components of the structure will be cleaned (e.g., high-pressure washing) within the containment area. Any liquid or solids resulting from the cleanup will be properly characterized and sent for treatment, storage, or disposal as appropriate. Inspection will be performed to verify that decontamination is complete.

After demolition has been completed, any equipment remaining onsite for further use will be cleaned (e.g., high-pressure washing) in a designated paved area or in another concrete containment area. Any liquid or solids resulting from the cleanup will be properly characterized and sent for treatment, storage, or disposal as appropriate.

The site will be graded and covered with stone mix, asphalt, concrete, or topsoil that will be seeded to provide a vegetative cover.

Structures may be retained for non-hazardous service. If so, the interior and exterior of the building will be thoroughly cleaned (e.g., scraping and high-pressure washing) to ensure that all hazardous waste constituents are removed. Areas may be wipe tested, if necessary, to show that the building has been thoroughly decontaminated.

4. Sampling and Analysis Procedures

Wastes generated from the decontamination/demolition activities will be collected, characterized according to the facility Waste Analysis Plan (Attachment XIV.A3) and managed accordingly.

5. Additional Waste Management Procedures

Chemical neutralizers and other spill control devices and procedures will be employed to manage any spills resulting from pipe drainage during the disconnection and dismantling process. Spill-saturated soils and spill control pillows will be contained and managed appropriately.

A11.A.5(b) Closure of Tank Systems [R 299.9615 and 40 CFR §264.197]

This section describes the procedures for closure of the V-101, V-301, V-302, V-303, V-401, V-402, V-403, V-404, V-601, V-701, 1163 Building and 33 Building tank systems located at the Dow Michigan Operations facility. There are no Tank Systems located at the Salzburg Landfill facility. When closure of these units actually occurs at this facility, Dow will prepare a detailed plan including engineering designs and procedures to implement the closure activities for each tank system to comply with Part 111 of Act 451, or applicable regulations at the actual time of closure.

Although closure of the individual units may be done at separate times, the general closure requirement and specific closure procedures are discussed below.

The proposed closure schedule is depicted in Appendix A11-1 of this Attachment.

A. General Closure Requirement

At closure of the tank system, the Dow Michigan Operations facility will remove or decontaminate all waste residues, contaminated containment system components (liners, etc.), contaminated soils, and structures and equipment contaminated with waste, and manage them as hazardous waste, unless 40 CFR §264.3(d) applies. Due to the history of the site and the location of these tank units, clean closure is not practical. Therefore, the tank system will be managed in accordance with the closure and postclosure care requirements that apply to landfills.

B. Specific Closure Procedures

Specific procedures for inventory management, unit inspection, decontamination, sampling and analysis, and additional waste management are discussed below.

1. Inventory and Remedial Waste Management Procedures

All hazardous waste remaining in the tank systems will be removed for transport to an appropriately licensed treatment or storage facility.

The tank systems will then be cleaned by scraping, shoveling, or power washing to remove any residues of spillage. Any liquid or solids resulting from the cleanup will be placed in drums or packs and sent for treatment, storage, or disposal as appropriate.

2. Unit Inspection Procedures

After removal of all containerized waste, the walls and floors of the units will be visually inspected for any signs of contamination by hazardous waste or hazardous waste constituents.

3. Decontamination Procedures

If the buildings are to be abandoned, they will be demolished. Demolished components of the building structures will be cleaned via high-pressure washing within in the containment structure, and rinseate generated will be collected and tested according to the sampling and analysis procedures (Subsection 4, below). Inspection will be performed to verify that decontamination is complete. Decontaminated metal and metal piping components will be sold as scrap. Decontaminated or uncontaminated building rubble (concrete, wood, etc) will be disposed of in an appropriately licensed landfill.

After demolition has been completed, any equipment remaining onsite for further use will be cleaned via high-pressure washing in a designated paved area or in another concrete containment area. Rinseate generated will be collected and tested according to the sampling and analysis procedures (Subsection 4, below).

Any solid residues from the equipment cleaning operation will be collected and managed at an appropriately licensed waste facility.

The site will be graded and covered with stone mix, asphalt, concrete, or topsoil that will be seeded to provide a vegetative cover.

The building(s) may be retained for non-hazardous service. If so, the interior and exterior of the building(s) will be thoroughly cleaned by scraping and high-pressure washing to ensure that all

hazardous waste constituents are removed. Areas may be wipe tested, if necessary, to show that the building has been thoroughly decontaminated.

4. Sampling and Analysis Procedures

Wastes generated from the decontamination/demolition activities will be collected, characterized according to the facility Waste Analysis Plan (Attachment XIV.A3) and managed accordingly.

5. Additional Waste Management Procedures

Chemical neutralizers and other spill control devices and procedures will be employed to manage any spills resulting from pipe drainage during the disconnection and dismantling process. Spill-saturated soils and spill control pillows will be contained and managed appropriately.

A11.A.5(c) Closure of Surface Impoundments [R 299.9616 and 40 CFR §264.228(a)(1) and (2)]

This section describes the procedures for closure of Tertiary Pond, located at Dow Michigan Operations Midland Plant facility. There are no surface impoundments located at the Salzburg Landfill facility. When closure of this unit actually occurs at this facility, Dow will prepare a detailed plan including engineering designs and procedures to implement the closure activities for this surface impoundment to comply with Parts 111 and 201 of Act 451, or applicable regulations at the actual time of closure.

The general closure requirement and specific closure procedures are discussed below.

The proposed closure schedule is depicted in Appendix A11-1 of this Attachment.

A. General Closure Requirement

At closure, the Dow Michigan Operations facility will:

1. Remove or decontaminate all waste residues, contaminated containment system components (liners, etc.), contaminated subsoil, and structures and equipment contaminated with waste and leachate, and manage them as hazardous waste unless 40 CFR §261.3(d) applies; or
2. Eliminate free liquids by removing liquid wastes or solidifying the remaining wastes and waste residues;
3. Stabilize remaining wastes to a bearing capacity sufficient to support final cover; and
4. Cover the surface impoundment with a final cover designed and constructed to:
 - a. Provide long-term minimization of the migration of liquids through the closed impoundment;
 - b. Function with minimum maintenance;
 - c. Promote drainage and minimize erosion or abrasion of the final cover;

- d. Accommodate settling and subsidence so that the cover's integrity is maintained;
and
- e. Have permeability less than or equal to the permeability of any bottom liner system or natural subsoil present.

A determination has been made that it is not practical to achieve a clean closure of the Tertiary Pond. The technical evaluation (1997-2000) to identify alternatives for removal of Tertiary Pond solids has determined that there is no currently known technology that would prove practical for treatment of the remaining solids and soils that would be generated during a clean closure option in a timely fashion. The potential for groundwater contamination would also prevent a clean closure option.

Because clean closure is not an option, a Contingent Closure Plan is not required and will not be proposed. Closure, therefore, will follow the requirements of R 299.9613, R 299.9616, and 40 CFR 264.228(b). However, considering the closure method proposed by Dow for the Tertiary Pond, a significant extension of the closure schedule will be requested under the requirements of 40 CFR 264.113(a) and (b). The Tertiary Pond will comply with all postclosure requirements contained in R 299.9613 and 40 CFR §§264.117 through 264.119, including maintenance and monitoring throughout the postclosure care period.

B. Specific Closure Procedures

Specific procedures for inventory management, unit inspection, decontamination, sampling and analysis, and additional waste management are discussed below.

1. Inventory and Remedial Waste Management Procedures

The closed unit will consist of at least two main sections: a capped area from which sediments have been removed, and a containment facility for dewatering and final disposal of solid residues from the pond bottom. Engineering drawings that illustrate the Closure Plan are included in this section. The engineering drawings presented within are conceptual in nature for the Tertiary Pond closure. As stated above, when it is time for closure of this unit to be considered, a detailed closure plan consisting of construction specifications and engineering drawings, will be submitted to the MDEQ-OWMRP, for review and approval. At the time of submittal, current design technology and Part 111 of Act 451, or applicable regulations will be considered in preparation of the actual closure plan. Brief explanations of the drawings are given below.

Final Capping Layout (B2-500-927122)

This conceptual drawing shows an overall plan view of the closed facility. Both the area isolating the pond sludges (New Containment Facility) and the Remaining Tertiary Pond area are shown.

Final Capping Layout Cross-Section (B2-501-927122 - B2-503-927122)

These conceptual drawings represent cross section "A" through "C" shown on B2-500. Drawing B2-501 shows a general cross-section (Section A) of both closed areas of the ponds. Groundwater collection trenches, drainage, sludge placement, and general capping layout can be seen.

Drawing B2-502 shows a general cross-section (Section B) of the New Containment Facility area. Also shown are detailed cross-sections of the top liner and bottom liner systems.

Drawing B2-503 shows a general cross-section (Section C) of the remaining pond area and a detailed cross-section of the capping system that would be employed.

Surface Drainage Collection System (B2-505-927122)

Shown on this drawing is a conceptual surface contouring plan and the surface drainage collection system. Detailed at the top of the drawing are the surface drainage collection sump and force main collection sump.

Dewatering Weir System (B2-506-927122)

This drawing outlines a weir system that might be used to dewater the sludges during excavation or dredging operations. Weir box locations and designs are shown.

Leachate Collection System (B2-507-927122)

Outlined on this drawing are the leachate collection and leak detection systems. A general plan view is shown as well as typical cross sections showing slopes and drainage media.

Initial Site Work

Any additional field data necessary to delineate parameters, such as hydrogeological conditions, will be collected as needed.

All disinventoring of the Tertiary Pond water will occur as necessary following the Dow NPDES permit requirements. Conformance will be maintained with the pond's NPDES outfall permit requirements.

A clay dike will be constructed to isolate a portion of the pond for the construction of the containment facility. The New Containment Facility shall be used for dewatering and permanent on-site disposal of pond waste residues.

(The dike is shown on drawing B2-500-927122 between the New Containment Facility Area and the Remaining Tertiary Pond Area).

Waste sludges from the upper two ponds (Pentagonal and Rectangular) and the designated containment area shall be excavated using hydraulic dredges. The sludges will be placed in the area labeled "Remaining Tertiary Pond Area" on drawing B2-500-927122.

Once dredging has been completed, the bottom of the New Containment Facility will be scraped to remove any surface materials to visibly clean conditions. Scrapings shall be transported and discharged into the Remaining Tertiary Pond Area with the other existing residues. Soil boring cores may be taken to delineate any remaining contamination.

The Tertiary Pond Revetment Groundwater Intercept System (RGIS) currently installed around the Tertiary Pond will be utilized as a groundwater collection system. It will be expanded to go around the Tertiary Pond as needed to address any additional containment issues (the location of the Tertiary Pond RGIS groundwater collection trench is shown on Drawing B2-001-917801 in Attachment XIV.B5).

The collection trench consists of a collection tile at the base of the trench in a coarse stone bedding, a sand trench backfill, a clay cap to minimize surface infiltration into the trench system, and an adequate number of cleanout lines for operational maintenance of the collection tile system.

The force main system used to transfer collected water to the Wastewater Treatment Plant is constructed of high density polyethylene pipe.

Construction of New Containment Facility

The existing pond bottom shall be excavated and graded to develop adequate slope for the New Containment Facility's drainage system.

The New Containment Facility bottom liner system will consist of, and be constructed in, the following sequence:

A three foot thick compacted clay liner, which has a permeability of 1×10^{-7} cm/sec or less, will be placed on top of the sub-base.

A 60 mil secondary geo-membrane will be placed on top of the three foot compacted clay liner.

A leak detection system will be placed above the secondary geo-membrane. The detection system will consist of a geo-synthetic drainage composite placed up the side walls and perforated collection pipes running horizontally on top of the three foot clay liner. The collection pipes will be covered with drainage media to an average depth of twelve inches over the entire surface of the three foot clay liner. The liquid collected by the leak detection system will gravity drain to a collection sump.

A five foot thick compacted clay liner, which has a permeability of 1×10^{-7} cm/sec or less, will be placed above the leak detection system.

An 80 mil primary geo-membrane will be placed on top of the five foot clay liner over the entire surface of the New Containment Facility and keyed into the top of the dikes using an earth-filled trench.

A leachate collection system consisting of perforated pipe covered with a twelve inch (minimum) drainage media layer will be installed above the primary geo-membrane. Leachate collection pipes will gravity drain to a collection sump where collected water shall be transferred to the Dow Michigan Operations Wastewater Treatment Plant using the same force main system as the groundwater collection trench system.

Along with the leachate collection pipe system, a dewatering dike with adjustable weirs will be built inside the facility to aid in the sludge dewatering process. The clay dike will be constructed on top of the five foot clay liner and covered with a geomembrane. This dike will become an integral part of the facility's containment system. (Schematics of the weir system and liner system can be found on Drawings B2-506 and 507-927122, respectively.)

(Detail #1 on Drawing B2-502-927122 shows the bottom liner system.)

Sound construction techniques and quality assurance programs will be utilized during all phases of liner construction to assure construction specifications are being met.

Dredging and Final Waste Excavation and Disposal into New Containment Facility Area

Dredging of the remaining pond area will occur to remove residue solids. The necessary liquid levels will be maintained in the remaining pond area for the dredging operations. The dredged material will be placed in the New Containment Facility Area for dewatering.

Once dredging has been completed, the pond bottom will be scraped to remove additional visible waste residues that may exist. Scrapings shall be transported and also placed in the New Containment Facility Area. Placement of the waste slurry into the facility will be as even as possible to facilitate dewatering and load distribution within the facility.

Additional methods of sludge dewatering/stabilization may be used as needed.

The pumping equipment, lines, and earth moving equipment will be cleaned by high pressure washing in accordance with MDEQ-OWMRP policy such that it is free of contamination and the water will be collected and treated through the Dow Michigan Operations Wastewater Treatment Plant.

Capping of Remaining Tertiary Pond Area

Clean fill material and/or shaping of the existing subbase shall be done to create a positive surface drainage in order to minimize the potential for ponding to occur.

The final cover for the remaining pond area will be consistent with R 299.9616 depending on the degree of remaining contamination. (Details of the Remaining Pond Area conceptual cap are shown on Drawing B2-503-927122.) Other alternatives to capping may be evaluated, including, but not limited to, de-listing the waste.

The entire cap will be seeded and fertilized to establish vegetative cover to minimize erosion. The program for seeding and fertilizing that will be proposed in the final closure plan will be similar to the following:

- Spread 20-26-6 fertilizer at 250 lb/acre.
- Seed 200 lb/acre of the following custom blend:

Annual Rye	20%
Wintergreen Fescue	15%
Common Kentucky Bluegrass	30%
Ruby Creeping Red Fescue	15%
Scalidis Hard Fescue	20%

- Cover side slopes with an erosion control fabric to hold seed and minimize erosion, as needed.

Surface run-off shall be collected around the perimeter of the cap by earth formed drainage ditches. An option will be for the ditches to drain to collection sumps around the perimeter of the cap where the water will be pumped off-site via a high density polyethylene force main system. This system will be separate from the groundwater and leachate collection force main system. The total pumping capacity of the collection sumps system will be designed to handle the cap run-off system from a 24-hour 100-year frequency rain storm. This conceptual option

for stormwater management is presented in Drawing B2-505-927122. A detailed stormwater management/capping profile, considering both gravity control and/or pumping options, will be presented for review and approval when required for closure.

Sound construction techniques and quality assurance programs will be utilized during all phases of work to assure capping specifications are met.

Final Capping of New Containment Facility Area

Waste material in the containment facility shall be dewatered and stabilized to an adequate bearing capacity to support the final cap and minimize any long-term settlement.

General fill material shall be placed over the top of the waste material and graded for surface drainage. A minimum of one percent slope will be maintained to eliminate the potential for ponding to occur.

The final cover will consist of a three foot thick compacted clay layer (permeability of 1×10^{-7} cm/sec or less), a 40 mil synthetic membrane, a geosynthetic drainage composite (1×10^{-3} cm/sec) or other equivalent cap system as allowed under R 299.9619(6), and a two foot thick layer of soil material which will support vegetative growth. (An example of a final capping system is shown in detail #2 on Drawing B2-502-927122.)

As soon as possible after placement of the soil layer, the cover will be seeded and fertilized to establish vegetative cover and to minimize erosion. The same vegetative cover design and procedure previously used for the area outside of the containment facility shall be used.

Similarly, final cap surface contouring and methods of surface drainage collection and erosion control (based on a 24-hour, 100-year rain event) will be implemented for the New Containment Facility Area cap as they were for the capped area outside of the facility.

A gas vent collection and control system shall be installed to properly collect and discharge gases that may be generated within the facility.

Sound construction techniques and quality assurance programs will be utilized during all phases of work to assure capping specifications are met.

2. Unit Inspection Procedures

Once the Tertiary Pond bottom has been scraped, it will be visibly inspected to ensure visible waste residues have been removed. Soil boring cores or surface samples may be taken to delineate any remaining contamination.

3. Decontaminating Procedures

After closure has been completed, any equipment remaining onsite for further use will be cleaned via high-pressure washing in a designated area or in another concrete containment area. Rinseate generated will be collected and tested according to the sampling and analysis procedures (Subsection 4, below).

4. Sampling and Analysis Procedures

Wastes generated from the decontamination/demolition activities will be collected, characterized according to the facility Waste Analysis Plan (Attachment XIV.A3) and managed accordingly.

5. Additional Waste Management Procedures

Chemical neutralizers and other spill control devices and procedures will be employed to manage any spills resulting from pipe drainage during the disconnection and dismantling process. Spill-saturated soils and spill control pillows will be contained and managed appropriately.

A11.A.5(d) Closure of Waste Piles [R 299.9617 and 40 CFR §264.258]

This section does not apply, as there are no Waste Piles at the Dow Michigan Operations Facility.

A11.A.5(e) Closure of Landfills [R 299.9619 and 40 CFR §264.310(a)]

This section describes the procedures for closure of the Salzburg Landfill facility. There are no landfills at the Dow Michigan Operations Midland Plant facility. The general closure requirement and specific closure procedures are discussed below. This closure plan is designed to ensure that the Salzburg Landfill facility is closed in a manner that minimizes the need for further maintenance; and controls, minimizes or eliminates, to the extent necessary to protect human health or the environment, post-closure escape of hazardous waste, hazardous constituents, leachate, contaminated run-off, or hazardous waste decomposition products to the ground, surface water, or atmosphere.

A. General Closure Requirement and Closure Performance Standard

At the final closure of the landfill or upon closure of any cell, the Salzburg Landfill will cover the landfill or cell with a final cover designed and constructed to:

1. Provide long-term minimization of migration of liquids through the closed landfill;
2. Function with minimum maintenance;
3. Promote drainage and minimize erosion or abrasion of the cover;
4. Accommodate settling and subsidence so that the cover's integrity is maintained; and
5. Have a permeability less than or equal to the permeability of any bottom liner system or natural subsoil present.

After final closure, the Salzburg Landfill will comply with all postclosure requirements contained in R 299.9613 and 40 CFR §264.117, including maintenance and monitoring throughout the postclosure care period.

If evidence of leaks or spills, is detected, samples will be taken and analyzed to determine the extent, if any, of contamination in the soil, groundwater, surface water or air. If contamination can be attributed to the operation or closure of the facility and the contamination is at concentrations sufficient to pose a threat to human health or the environment; then the most suitable alternative to remedy the contamination will be implemented to ensure protection of public health and the environment. For more details see the Environmental Monitoring Plan found in Module (B5) of this application.

B. Specific Closure Procedures

The final landfill cover design, the construction quality assurance program for installing the final landfill cover, and plat of survey are presented below.

1. Landfill Cover Design

The final landfill cover conceptual design is presented in Part II of Section VI, Facility Design, Engineering, and Operating Standards Cell and Cap Construction, of this license application. Elevations on the Landfill Cells can be found in the following drawings: B2-100-853, B2-100-854, B2-200-853, and B2-200-854.

2. Construction Quality Assurance (CQA) Program

The detailed specifications and construction quality assurance requirements for each component of the cap will be addressed in the design documents submitted to EGLE for approval prior to construction.

3. Plat of Survey

A notation in the deed has been completed informing potential purchasers that the land has been used to manage hazardous wastes and its use is restricted under 40 CFR Part 264, Subpart G.

4. Maximum Inventory of wastes

Waste is not stockpiled at the facility for future disposal. Waste is only brought to the facility only when there is a licensed, active cell in which it can be placed. No storage or treatment occurs at the landfill. The total volume of waste placed in the cells is restricted by the design of the cell size and the thickness/amount of daily cover required.

5. Equipment Disposal/Decontamination and Soil removal

All equipment used for cap construction that contacts waste material will be thoroughly cleaned before being used on another project task or leaving the work site. The cleaning will be conducted

In accordance with 40 CFR 264.117(c), post-closure use may never be allowed to disturb the integrity of the final cover, liners, or any other components of the containment system, or the functions of the facility's monitoring system unless the EGLE Director finds that either the disturbance is necessary to reduce a threat to human health or the environment, or it is necessary for the proposed use of the property and will not increase the potential hazard to human health or the environment.

A11.A.5(f) Closure of Incinerators [R 299.9620 and 40 CFR §264.351]

This section describes the procedures for closure of 32 Building Incinerator and ancillary equipment, located at the Dow Michigan Operations Midland Plant facility. There are no incinerators located at the Salzburg Landfill facility. When closure of this unit actually occurs at this facility, Dow will prepare a detailed plan including engineering designs and procedures to

implement the closure activities for 32 Building Incinerator to comply with Part 111 of Act 451, or applicable regulations at the actual time of closure.

The general closure requirement and specific closure procedures are discussed below.

A. General Closure Requirement

At closure the Dow Michigan Operations facility will remove all hazardous waste and hazardous waste residues (including, but not limited to, ash, scrubber waters, and scrubber sludges) from the incinerator site.

B. Specific Closure Procedures

Specific procedures for inventory management, unit inspection, decontamination, sampling and analysis, and additional waste management are discussed below.

1. Inventory and Remedial Waste Management Procedures

After closure has been initiated and final volumes of waste have been received for incineration, any waste inventory that remains will be processed through the incinerator. To the degree possible, all remaining tank heels and other residual wastes will be processed through the incinerator. All hazardous waste and hazardous waste residues will be removed from the incinerator, associated ductwork, piping, air pollution control equipment sumps and any other structures or operating equipment that have come in contact with the hazardous waste. Ash, refractory and treatment residues will be characterized according to the sampling and analysis procedures (Subsection 4, below), and disposed of in an appropriately licensed landfill or treatment facility.

2. Unit Inspection Procedures

After removal of all waste and ancillary equipment, the concrete floors and drains will be visually inspected for any signs of contamination by hazardous waste or hazardous waste constituents.

3. Decontamination Procedures

The waste combustion systems will be decontaminated by high-pressure washing.

After removal of waste has been completed, dismantling of the process equipment will commence. Process equipment will be dismantled into segments by utilizing cutting torches where possible. All piping, pumps, and equipment will be solvent cleaned, visually inspected and wipe-tested prior to disposal or scrapping. Metal components will be sold for scrap. Refractory will be disposed of in Dow's licensed hazardous waste landfill. Any solid residues from the equipment cleaning operation will be collected and managed at an appropriately licensed waste facility.

If buildings are to be abandoned, they will be demolished. Demolished components of the building structure will be cleaned via high-pressure washing within a secondary containment area, and rinseate generated will be collected and tested according to the sampling and analysis procedures (Subsection 4, below). Inspection will be performed to verify that decontamination is complete. Decontaminated metal building components will be sold as scrap.

Decontaminated or uncontaminated building rubble (concrete, wood, etc) will be disposed of in an appropriately licensed landfill.

After dismantling and demolition has been completed, any equipment remaining onsite for further use will be cleaned via high-pressure washing in a designated paved area or in another concrete containment area. Rinseate generated will be collected and tested according to the sampling and analysis procedures (Subsection 4, below).

Demolition of foundation structures will commence when the area is cleared of demolition materials and equipment from the demolition of the incinerator units themselves. Sewer discharge lines to the main plant sewer will be cleaned and removed. The site will be graded and covered with stone mix, asphalt, concrete, or topsoil that will be seeded to provide a vegetative cover.

The building may be retained for non-hazardous service. If so, the interior and exterior of the building will be thoroughly cleaned by scraping and high-pressure washing to ensure that all hazardous waste constituents are removed. Areas may be wipe tested, if necessary, to show that the building has been thoroughly decontaminated.

4. Sampling and Analysis Procedures

Wastes generated from the decontamination/demolition activities will be collected, characterized according to the facility Waste Analysis Plan (Attachment XIV.A3) and managed accordingly.

5. Additional Waste Management Procedures

Chemical neutralizers and other spill control devices and procedures will be employed to manage any spills resulting from pipe drainage during the disconnection and dismantling process. Spill-saturated soils and spill control pillows will be contained and managed appropriately.

A11.A.5(g) Closure of Miscellaneous Units
[R 299.9623 and 40 CFR §§264.601 through 264. 603]

This section does not apply, as there are no Miscellaneous Units at the Dow Michigan Operations facility.

A11.A.5(h) Closure of Boilers and Industrial Furnaces (BIF)
[R 299.9808 and 40 CFR §266.102(e)(11)]

This section does not apply, as there are no Boilers and Industrial Furnaces (BIF) Units at the Dow Michigan Operations facility.

A11.A.5(i) Other Closure Activities
[R 299.9504(1)(c), R 299.9508(1)(b), and R 299.9613(1) and 40 CFR §§270.14(b)(13) and 264.112(b)(5)]

At final facility closure of the Salzburg Landfill facility; the facility building, and the vehicle wash building will be demolished and removed. Any operating equipment leaving the site will be washed before removal.

A11.A.6 Certification of Closure
[R 299.9613]

Within 60 days of completion of closure the Dow Michigan Operations facility will submit to the Director, by registered mail, a certification that the hazardous waste management unit or facility, as applicable, has been closed in accordance with the specifications in the approved closure plan. The certification will be signed by the Dow Chemical Company and by an independent registered professional engineer. Documentation supporting the independent registered engineer's certification will be furnished to the Director in accordance with R 299.9613(3), including:

1. The results of all sampling and analysis;
2. Sampling and analysis procedures;
3. A map showing the location where samples were obtained;
4. Any statistical evaluations of sampling data;
5. A summary of waste types and quantities removed from the site and the destination of these wastes; and
6. If soil has been excavated, the final depth and elevation of the excavation and a description of the fill material used.

The Dow Michigan Operations facility will maintain financial assurance for closure until the Director releases the Dow Michigan Operations facility from the financial assurance requirements for closure under R 299.9703.

The certification must be worded as follows:

I certify under penalty of law that this document and all attachments were prepared under my direction or supervision in accordance with a system designed to assure that qualified personnel properly gather and evaluate the information submitted. Based on my inquiry of the person or persons who manage the system, or those persons directly responsible for gathering the information, the information submitted is, to be the best of my knowledge and belief, true, accurate, and complete. I am aware that there are significant penalties for submitting false information, including the possibility of fine and imprisonment for knowing violations.

A11.A.7 Postclosure Notices Filed
[R 299.9504(1)(c) and R 299.9508(1)(b) and 40 CFR §270.14(b)(14)]

The applicant must provide documentation that the postclosure notices required under 40 CFR §264.119 have been filed for hazardous waste disposal units that have been closed at the facility.

A11.B POSTCLOSURE PLAN
[R 299.9613 and 40 CFR §264.118]

A11.B.1 Applicability

(Check as appropriate)

Not applicable: Hazardous waste will not be left behind at closure. A survey plat, postclosure care, postclosure certifications, and other notices are not required.

Applicable:

Contingent plan

Landfill unit

A11.B.2 Postclosure Care Objectives

The Dow Michigan Operations facility will complete the activities listed in Table A.11.B.1 in order to achieve the following:

1. Maintain the integrity and effectiveness of the final cover, including making repairs to the cap as necessary to correct the effects of settling, subsidence, erosion, or other events;
2. Operate the leachate collection and removal system until leachate is no longer detected;
3. Maintain and monitor the leak detection system in accordance with R 299.9613 and 40 CFR §§264.301(c)(3)(iv) and (4) and 264.303(c), and comply with all other applicable leak detection system requirements of this part;
4. Maintain and monitor the groundwater monitoring system and comply with all other applicable requirements of R 299.9612 and 40 CFR, Part 264, Subpart F;
5. Prevent run-on and run-off from eroding or otherwise damaging the final cover; and
6. Protect and maintain surveyed benchmarks used in complying with R 299.9613 and 40 CFR §264.309.

A11.B.3 Postclosure Care Period Point of Contact

The planned monitoring and maintenance activities and the associated frequencies are designed to ensure the integrity of the cap and final cover system and the proper functioning of the monitoring system for each unit listed in Table 11.B.1. The point of contact for ensuring the performance of these activities is listed below.

Name and/or Title	Responsible Care Leader, Michigan Operations
Address	1790 Building, Midland, MI 48674
Telephone	989-633-7384

A11.B.4 Postclosure Care Activities

Table A11.B.1 Postclosure Monitoring and maintenance

The following table identifies, for each unit requiring postclosure care, planned monitoring and maintenance activities and the frequency at which these activities will be performed. For Waste Storage Area I, the previously closed Waste Storage Areas IIA and IIB, and the previously closed 703 and 830 Incinerators, postclosure monitoring and maintenance will be consistent with the 1925 Landfill Corrective Action Monitoring and Maintenance Plan submitted October 1, 2010.

Unit	Planned Monitoring Activities	Frequency	Planned Maintenance Activities	Frequency
Tertiary Pond	Leachate Collection Sump	Annually		
	Leak Detection Sump	Quarterly		
	Groundwater Monitoring Wells	Annually	Check condition of the well casings, caps, and pumps and repair, if necessary.	Semi-annually
	8' Security Fence and signs	Weekly	Signs will be replaced as they become illegible. Soil at the base of the fence will be regraded. Fence will be maintained	As needed
	Pumps and valves	Continuously		
	Erosion	Monthly	Washouts will be repaired. Restoration of vegetative cover will be performed.	
	Vegetative Cover	During spring and fall growth seasons	Vegetative Cover maintenance will include reseeded, watering, fertilizing. Tree or brush growth will be prevented.	
	Run-on and Run-off	Twice a year during rain events	Drainage sumps and ditches will be cleaned and maintained.	
	Settlement	Spring and fall and once a year during a rain event	Benchmarks will be checked against USGS benchmark located on Poseyville Road. Benchmarks will be reestablished if necessary. Settlement that causes ponding will be repaired by adding fill to regain an adequate slope. Vegetative cover will be restored.	Every 3 years
	Leak Detection System	Twice a year. If the leachate dewatering rates decline to 10% of initial flow levels, this will be reduced to once/year	Repair or replacement of the defective equipment.	As needed
Groundwater Collection System/Force Main Systems	Twice a year	Pumps and or related instrumentation will be repaired or replaced. Collection pipes will be cleaned through clean-out ports.		

	Groundwater Monitoring Wells	Twice a year	Damaged casing will be repaired or replaced.
	Gas Venting Systems	Annually	Damaged vents will be repaired or replaced.

Unit	Planned Monitoring Activities	Frequency	Planned Maintenance Activities	Frequency
Closed Diversion Basin and Open Waste Water Conduits A, B, C-1, C-2, and C-3	Erosion	Monthly (during spring and fall)	Washouts will be repaired.	As needed
	Settlement	Spring and fall	Restoration of vegetative cover will be performed.	
			Settlement that causes ponding will be repaired by adding fill to regain an adequate slope. Vegetative cover will be restored.	
	Run-on and Run-off	Twice a year during rain events	Settlement areas with asphalt cover will be filled as necessary with either additional asphalt or a combination of fill (typically sand or crushed stone) and asphalt.	
			Drains and swales will be cleaned and maintained to allow free drainage so that unintentional retention of stormwater is minimized	
	Vegetative Cover	Monthly during spring and fall growth seasons	High velocity run-off areas will be protected with either coarse stone or paving to insure minimal erosion.	
			Vegetative cover maintenance will include reseeding, watering, and fertilizing.	
	Asphalt and Stone Mix Cover	Annually	Tree or brush growth will be prevented over the actual cover areas.	
Repair or replacement of cracked heaved areas.				
Security	Daily	Signs will be replaced as they become illegible.		

Unit	Planned Monitoring Activities	Frequency	Planned Maintenance Activities	Frequency
Closed Sludge Dewatering Facility	Erosion	Monthly (during spring and fall)	Washouts will be repaired.	As needed
			Restoration of vegetative cover will be performed.	
	Vegetative Cover	Monthly during spring and fall growth seasons	Vegetative cover maintenance will include reseeding, watering, and fertilizing.	
			Tree or brush growth will be prevented over the actual cover areas.	
	Operation of the lift station pump	Daily	Repair or replace the equipment.	
	Lift station (Lift Station 50) level	Daily		
	Operation of the flow meter	Daily		
	Monitoring Wells	Twice a year	Cracked casings and/or the protective structures will be repaired.	
	Benchmarks	Annually	Benchmarks will be reestablished if necessary.	
	Security	Daily	Signs will be replaced as they become illegible.	
Gate is locked and the fencing is in good repair.				
Sump Drains	Annually	Tiles will be jetted to prevent sediment buildup that might block the collection tiles and cause liquid to backup into the cells	Annually	

Unit	Planned Monitoring Activities	Frequency	Planned Maintenance Activities	Frequency
Waste Storage I	Erosion	Twice annually (2X per year)	Final cover will be inspected for washouts during spring and fall when ground is not frozen.	As needed

			Restoration of vegetative cover will be performed.	
	Settlement	Twice annually (2X per year) Spring and fall	Unanticipated ponding will be repaired by adding fill and re-grading to establish surface drainage. Vegetative cover will be restored.	
	Final Cover	Twice annually (2X per year) Spring and fall	Areas of bituminous or aggregate cover identified to have cracks or settlement that cause exposure of in-place, subsurface waste will be repaired by filling or sealing.	
			Vegetative cover will include reseeded, watering, and fertilizing.	
	Run-off and Run-on Control	Twice annually (2X per year) Spring and fall	Drainage swales to divert storm water across site will be checked to assure proper drainage.	

Unit	Planned Monitoring Activities	Frequency	Planned Maintenance Activities	Frequency
Closed Waste Storage Areas IIA and IIB	Erosion	Twice annually (2X per year)	Final cover inspected for washouts during spring and fall when ground is not frozen. Restoration of vegetative cover will be performed.	As needed
	Settlement	Twice annually (2X per year) Spring and fall	Unanticipated ponding will be repaired by adding fill and re-grading to establish surface drainage. Vegetative cover will be restored.	
	Final Cover	Twice annually (2X per year) Spring and fall	Areas of bituminous or aggregate cover identified to have cracks or settlement that cause exposure of in-place, subsurface waste will be repaired by filling or sealing.	
			Vegetative cover will include reseeded, watering, and fertilizing.	
Run-off and Run-on Control	Twice annually (2X per year) Spring and fall	Drainage swales to divert storm water across site will be checked to assure proper drainage.		

Unit	Planned Monitoring Activities	Frequency	Planned Maintenance Activities	Frequency
------	-------------------------------	-----------	--------------------------------	-----------

Closed 703 and 830 Incinerators	Erosion	Twice annually (2X per year)	Final cover inspected for washouts during spring and fall when ground is not frozen. Restoration of vegetative cover will be performed.	As needed
	Settlement	Twice annually (2X per year) Spring and fall	Unanticipated ponding will be repaired by adding fill and re-grading to establish surface drainage. Vegetative cover will be restored.	
	Final Cover	Twice annually (2X per year) Spring and fall	Areas of bituminous or aggregate cover identified to have cracks or settlement that cause exposure of in-place, subsurface waste will be repaired by filling or sealing.	
			Vegetative cover will include reseeded, watering, and fertilizing.	
Run-off and Run-on Control	Twice annually (2X per year) Spring and fall	Drainage swales to divert storm water across site will be checked to assure proper drainage.		

Unit	Planned Monitoring Activities	Frequency	Planned Maintenance Activities	Frequency
Salzburg Landfill	Security	Quarterly	Signs will be replaced as they become illegible. Fencing is maintained in good repair.	As needed
	Erosion	Quarterly (when ground is not frozen)	Washouts will be repaired Restoration of vegetative cover will be performed.	
	Vegetative Cover	Quarterly (Spring and Fall)	Vegetative cover maintenance will include reseeded, watering, and fertilizing.	
			Tree or brush growth will be prevented over the actual cover areas.	
			Mowing will be performed when deemed necessary. Rule of thumb is approximately 12 inches.	
	Burrowing Animals	Quarterly	Eliminate burrowing animals and maintain/repair burrows.	
	Settlement; Visual	Quarterly (Spring and Fall and after at least one rain event per year)	Unanticipated ponding will be repaired by adding fill and regrading to establish surface drainage. Vegetative cover will be restored.	
Settlement; Postclosure Survey	First survey will be the determination of the as-built elevations when cap is constructed. Second survey will be 3 years after cap construction.	Repair. Significant* repair may need prior approval before repairs are implemented.		

	Gas Venting Systems	Annually	Repair or replacement of defective equipment.
	Liner Failure Detection System Lift stations, pumps, visible piping, and instrumentation checked for proper operation.	Monthly	Repair or replacement of defective equipment.
	Leachate Collection System Lift stations, pumps, visible piping, and instrumentation checked for proper operation.	Monthly. If leachate generation rates decline to 10% of active operation flow rates, frequency will be reduced to twice/year.	Repair or replacement of defective equipment.
	Groundwater Monitoring Wells Condition of well casings, caps, and pumps checked.	Semi-annually	Repair or replacement of defective equipment.
	Benchmarks Moved or damaged.	Quarterly	Reset and re-established. Resurvey every 3 years.
	Run-on and Run-off Sumps and surface water ditches checked to ensure adequate drainage.	Quarterly	Cleaned and maintained.

* Indicators that "significant" settlement may have occurred include:

- The elevation of a survey point changes by more than 0.5 feet in elevation between surveys;
- A 30% flattening of the cap slopes, i.e., a 1% cap slope reduces to a 0.7% slope or a 2% slope reduces to a 1.4% slope; or
- "Significant" ponding on the cap is noted during a post-rain event visual inspection.

If, at any time, the quarterly visual inspection indicates that settlement may be an issue, the need for an additional cap elevation survey will be discussed with EGLE.

Details on the Salzburg Landfill Post closure cap survey can be found in the Post Closure Cap Elevation Survey Plan that is included in this module.

A11.B.5 Postclosure Care Plan Amendment
[R 299.9613 and 40 CFR §264.118(d)]

The Postclosure Care Plan will be amended whenever:

1. Changes in the operations or facility design will affect closure and postclosure care; or
2. There is a change in the expected year of closure, if applicable; or
3. Unexpected events during closure require a modification to the plan.

A11.B.6 Certification of Postclosure
[R 299.9613]

Within 60 days of completion of postclosure care Dow Michigan Operations facility will submit to the Director, by registered mail, a certification that postclosure care for the hazardous waste management unit or facility, as applicable, has been completed in accordance with the specifications in the approved postclosure plan. The certification will be signed by the owner/operator of Dow Michigan Operations facility and by an independent registered professional engineer. Documentation supporting the independent registered engineer's certification will be furnished to the Director in accordance with R 299.9613(5). The Dow Michigan Operations facility will maintain financial assurance for postclosure until the Director releases the Dow Michigan Operations facility from the financial assurance requirements for postclosure under R 299.9703 and 40 CFR §264.143(i).

The certification must be worded as follows:

I certify under penalty of law that this document and all attachments were prepared under my direction or supervision in accordance with a system designed to assure that qualified personnel properly gather and evaluate the information submitted. Based on my inquiry of the person or persons who manage the system, or those persons directly responsible for gathering the information, the information submitted is, to be the best of my knowledge and belief, true, accurate, and complete. I am aware that there are significant penalties for submitting false information, including the possibility of fine and imprisonment for knowing violations.

Appendix A11-1 Schedule for Closure

Closure Activity	Time Completed
Container Storage Areas – WSA I, 32 Pack Room, 830 Building, Offload Spots at the Incinerator, 703 Tank Farm Spots, and Rail Car Spots	
<i>Removal/disposal of final waste inventory</i>	<i>60 days</i>
<i>Removal/disposal of spillage</i>	<i>80 days</i>
<i>Demolition of any building and secondary containment and disposal of rubble</i>	<i>120 days</i>
<i>Soil Evaluation</i>	<i>140 days</i>
<i>Removal of contaminated soil, final site grading and seeding</i>	<i>170 days</i>
<i>Completion of closure and certification submittal to the director</i>	<i>180 days</i>
Tank Systems – V-101, V-301, V-302, V-303, V-401, V-402, V-403, V-404, V-601, V-701, 1163 Building & 33 Building	
<i>Removal/disposal of final waste inventory</i>	<i>90 days</i>
<i>Cleaning, demolition, and disposal of secondary containment</i>	<i>140 days</i>
<i>Soil testing</i>	<i>150 days</i>
<i>Removal of contaminated soil</i>	<i>170 days</i>
<i>Completion of closure and certification submittal to the director</i>	<i>180 days</i>
Surface Impoundment – Tertiary Pond	
<i>Pond Drainage</i>	<i>1 year</i>
<i>Construct new dike</i>	<i>1 year</i>
<i>Dredge upper two ponds</i>	<i>1 year</i>
<i>Dredge facility area</i>	<i>1 year</i>
<i>Grade/slope</i>	<i>2 years</i>
<i>Scrape/sample soil</i>	<i>1 year</i>
<i>Install drain trench</i>	<i>1 year</i>
<i>Construct facility</i>	<i>2 years</i>
<i>Dredge sludge into facility</i>	<i>3 years</i>
<i>Install force mains & sumps</i>	<i>3 years</i>
<i>Install drainage sumps</i>	<i>3 years</i>
<i>Dewater and stabilize sludge</i>	<i>3 years</i>
<i>Install remaining drain tile</i>	<i>3 years</i>
<i>Scrape bottom soils</i>	<i>3 years</i>
<i>Grade facility for drainage</i>	<i>3 years</i>
<i>Grade area outside of facility</i>	<i>3 years</i>
<i>Install 3 ft. cap and seed</i>	<i>3 years</i>
<i>Install HDPE cap liner</i>	<i>3 years</i>
<i>Place 5 ft. cap and seed</i>	<i>3 years</i>
<i>Place 2 ft. Cover and seed</i>	<i>3 years</i>
<i>Completions of closure and certification</i>	<i>3 years</i>

Closure Activity	Time Completed
32 Building Incinerator	
<i>Removal/disposal of final waste inventory</i>	<i>90 days</i>
<i>Removal and cleaning of unloading stations</i>	<i>90 days</i>
<i>Cleaning of Pack Room</i>	<i>90 days</i>
<i>Demolition of 32 incinerator</i>	<i>300 days</i>
<i>Demolition of ancillary equipment</i>	<i>600 days</i>
<i>Demolition of foundations</i>	<i>700 days</i>
<i>Completion of closure and certification</i>	<i>800 days</i>
Salzburg Landfill	
Mobilization	10 days
Site Grading & Gas Vent Installation	20 days
Subbase Preparation	30 days
Clay Liner Component (GCL)	70 days
Synthetic Liner Component	80 days
Drainage Collection Layer (GDM)	90 days
Erosion – Freeze Protection Layer	120 days
Closure Certification	160 days

CLOSURE AND POSTCLOSURE CARE PLANS - APPENDIX A11-2
SLUDGE DEWATERING FACILITY

Post Closure Cap Elevation Survey Plan

ATTACHMENT XIV.A11

APPENDIX A11-2

SLUDGE DEWATERING FACILITY

Introduction

This appendix contains historical information for the Dow Chemical Michigan Operations, Midland Plant Sludge Dewatering Facility (SDF). The information in this appendix was obtained primarily from the Closure Plan for the Sludge Dewatering Facility that was submitted to the Michigan Department of Environmental Quality (MDEQ) in July 1987 and from the document "Engineering Certification for Closure of the Sludge Dewatering Facility" that was submitted to the MDEQ - Waste Management Division in January 1990. These documents provide detailed descriptions and engineering drawings of the SDF site. The 1987 Closure Plan and 1990 Closure Certification documents should be referenced in conjunction with the following information.

A Post-Closure Plan for the SDF was submitted in July 1987 as part of the Closure Plan. The Post-Closure Plan covered groundwater monitoring (sampling, testing, and data evaluation), leak detection monitoring, inspection and security, maintenance, and post-closure care costs. The provisions of the July 1987 Post-Closure Plan are superseded by the conditions of this operating license attachment.

Property survey drawings containing descriptions of the individual cells were recorded at the Midland County Register of Deeds office May 15, 2001.

The integrity and effectiveness of the SDF final cover will be maintained throughout the post-closure care period. At the time of this reapplication process, Dow is not contemplating any future uses for the SDF property.

In accordance with 40 CFR 264.117(c), post-closure use may never be allowed to disturb containment system integrity or the functions of the SDF's monitoring system unless the MDEQ Director finds that either the disturbance is necessary to reduce a threat to human health or the environment, or is necessary for the proposed use of the property, and will not increase the potential hazard to human health or the environment.

A notice has been filed in the deed to notify any future owners of the SDF property regarding the historical use of the SDF property for hazardous waste disposal.

General Facility Description

The SDF is located on a 37-acre parcel at the southeast corner of Salzburg and Saginaw Roads in the City of Midland. The SDF is included within the facility boundary of the Michigan Operations, Midland Plant site, EPA Facility number MID 000 724 724, as indicated on Drawing B2-010-927122 which can be found in the general facility description module of this application.

The SDF was operated from 1974 until its closure was completed under interim status in 1989. Initially, the SDF was a clay borrow area in which a pit had been excavated as deep as 15 feet below grade. Its naturally occurring clay geology made it a suitable dewatering site. The SDF at closure was made up of eight cells, partitioned with compacted clay dikes, as indicated on Drawing B2-100-874006. The main constituents treated and/or disposed in the SDF were: primary sludge from the Michigan Operations Wastewater Treatment Plant (WWTP), sludge from closure of the Diversion Basin, and solids from the closure of the Open Wastewater Conduits. Cell 7 was also used by commercial trucking operations, whose facilities were located across Salzburg Road from the SDF. Flushings from their truck tankers were discharged into Cell 7 until 1984. For a period of six months in 1985, primary sludge from the Michigan Operation's Phenolic Wastewater Treatment Plant was also dewatered in Cell 7.

As part of the closure of the SDF, the existing perimeter leachate drain system was expanded, an internal sand drainage layer was added within the cells, a side wall leachate drain was placed on the perimeter inside slope of the cells, and a center leachate drain was constructed. The collection system primarily works by gravity drainage, except for the lift station (Lift Station 50) located in the center of the SDF. This Lift Station pumps the collected leachate into the return line that transports the liquid to the Michigan Operations WWTP for treatment. This extensive leachate collection system provides a zone of groundwater depression within the cells that extends to the surrounding layered clay and causes an inward hydraulic gradient that works to restrict flow out of the cells.

The cells were then capped with three feet of compacted clay, a polyethylene geomembrane, sand, topsoil, and vegetation.

Details of the closure, including drain installation, dike installation, slurry wall installation, clay cap and geomembrane installation, and soil cover installation are covered in the 1987 Closure Plan and 1990 Closure Certification.

Primary sludge from the WWTP consisted of approximately one to two percent solids, and was pumped intermittently to the SDF at an average rate of 360,000 gallons per day. The primary ions of the liquid portion were calcium, sodium, magnesium, chloride, sulfate, carbonate, and bicarbonate. The solids were largely inert silts from street runoff and calcium carbonate

precipitates resulting from waste neutralization. Minor constituents of the sludge include a wide variety of organic and inorganic compounds that are indicative of wastewater streams treated by the WWTP.

Because the sludge and solids from the Open Wastewater Conduits and Diversion Basin were generated from wastewater treatment activities (prior to neutralization) in the Michigan Operations, Midland Plant they have the same basic chemical characteristics as the primary solids described above. The sludges and solids were transported to the SDF via truck and contained a higher solid to liquid ratio (four to five percent solids) than did primary sludge.

SDF planned monitoring and maintenance activities and the frequency at which these activities will be performed are located in Table A11.B.1, Postclosure Monitoring and Maintenance, in section A11.B.4, Postclosure Care Activities, of this Attachment.

Cap Elevation Survey Plan
for
Salzburg Landfill
Rev. 1

Introduction

Dow undertook an investigation in August 2008 to determine if settlement was occurring on previously capped cells at Salzburg Landfill (SLF). The investigation was performed to establish a basis for specifying a time frame for future surveys of capped cells at SLF to ensure settlement was not becoming an issue.

The investigation involved surveying capped Cells #17 through #19 (Cells 17/19) and capped Cells #40 through #43 (Cells 40/43). Both of these cells were capped in 2005. The survey involved determining the current top of cap elevation at approximately 20 points, oriented in 3 cross sections. The survey results were compared to the original design elevations to determine if settlement was occurring.

The data from the August 2008 survey and the original design elevation comparison are shown on attached drawings B2-100-854 (Cells 17/19) and B2-100-853 (Cells 40/43). The average change in elevation for all of points surveyed on each cap is less than 0.1' from the plan elevations. The largest elevation deviation is in a line along the topsoil berm on the east side of Cells 17/19 (see Points 7, 14 & 21 on B2-100-854). The average elevation change for these three points is 0.3 feet. The current cap slope in this area was calculated and found to be very close to the design cap slope as shown in the following table:

<u>SURVEY POINT¹</u>	<u>CURRENT SLOPE BETWEEN POINTS</u>	<u>DESIGN SLOPE</u>
7	0.9%	1%
14	1.2%	1%
21		

These findings indicate that there are no settlement issues on the Cells 17/19 or Cells 40/43 caps. Dow believes this is true for all capped cells at Salzburg Landfill which is supported by these two facts:

1. Ponding has never occurred on any of the caps which are visually inspected after every ½" rainfall; and
2. No caps have experienced sink holes or differential settlement requiring a repair in the past 25 years.

Based on these findings and as required by Condition III.E.4 of the license, Dow proposes the Cap Elevation Survey Plan described below.

¹ These survey point numbers refer only to the 2008 survey. They will be replaced by new point numbers for future surveys.

Cap Elevation Survey Plan

- Determine the current elevation of each survey point shown on attached Drawings B2-200-1374 and B2-201-1374. These drawings are titled NORTH CELLS #1 THRU #19 and SOUTH CELLS #38 THRU #43, respectively.
- The circled number for each survey point shown on these drawings coincides with the SURVEY POINT NUMBER listed on the attached spreadsheets. The new survey data will be entered into the spreadsheet column titled (DATE) SURVEY ELEV (DATE refers to the date of the survey). Macros are included in the spreadsheets that automatically determine changes in elevation (Δ ELEV column) for a specific point or changes in slope (Δ SLOPE column) between adjacent points.
- The changes in elevation and slope will be reviewed by Dow and a report showing all data will be submitted to the Michigan Department of Natural Resources and Environment (MDNRE). The MDNRE and Dow will agree on a path forward for any cap locations where there are indications of significant settlement as described below.
- The periodicity for the post closure surveys on closed cells will be as follows:
 - First survey of all currently capped cells at SLF, Cells #1 thru #19 & Cells #38 thru #43, will be performed in 2010, or the year that currently active Cells 20/22 is capped. The first survey will also include establishing survey points on the Cells 20/22 cap. The survey point locations for Cells 20/22, and all cells capped in the future, will be established and agreed upon prior to starting the cap survey;
 - The data from the first survey of the Cells #1 thru #19 & Cells #38 thru #43 caps will be compared against the original design elevations and slopes for these caps which are indicated in columns labeled "DESIGN ELEVATION" and "DESIGN SLOPE TO PREVIOUS POINT" on the spreadsheets. If the MDNRE and Dow agree the results of the first survey indicate settlement is not an issue, the second survey of all capped cells will be performed 3 years after the first. The majority of cap settlement for Cells 20/22, if any, should occur within this time frame;
 - If the MDNRE and Dow agree the results of the 3-year survey indicate settlement is not an issue, the subsequent survey of all capped cells will be performed 5 years after the second;
 - If the MDNRE and Dow agree the results of the 5-year survey indicate settlement is not an issue, periodic surveys will then be performed every 10 years after that;
 - If, at any time, evidence is found indicating that settlement has become an issue, the periodicity of the surveys may be discussed and agreed upon with the MDNRE.
- Surveys of future cells capped after Cells 20/22:
 - First survey will be the determination of the as-built elevations when the cap is constructed;
 - Second survey will be 3 years after the cap is constructed. The majority of cap settlement, if any, should occur within this time frame; and
 - If the MDNRE and Dow agree the results of the 3-year survey indicate settlement is not an issue, this cap will then be surveyed as part of the next 10-year site survey.
- Indicators that "significant" settlement may have occurred:
 - The elevation of a survey point changes by more than 0.5 feet in elevation between surveys;
 - A 30% flattening of the cap slopes, i.e., a 1% cap slope reduces to a 0.7% slope or a 2% cap slope reduces to a 1.4% slope; or
 - Significant ponding on the caps is noted during the post-rain event inspections.

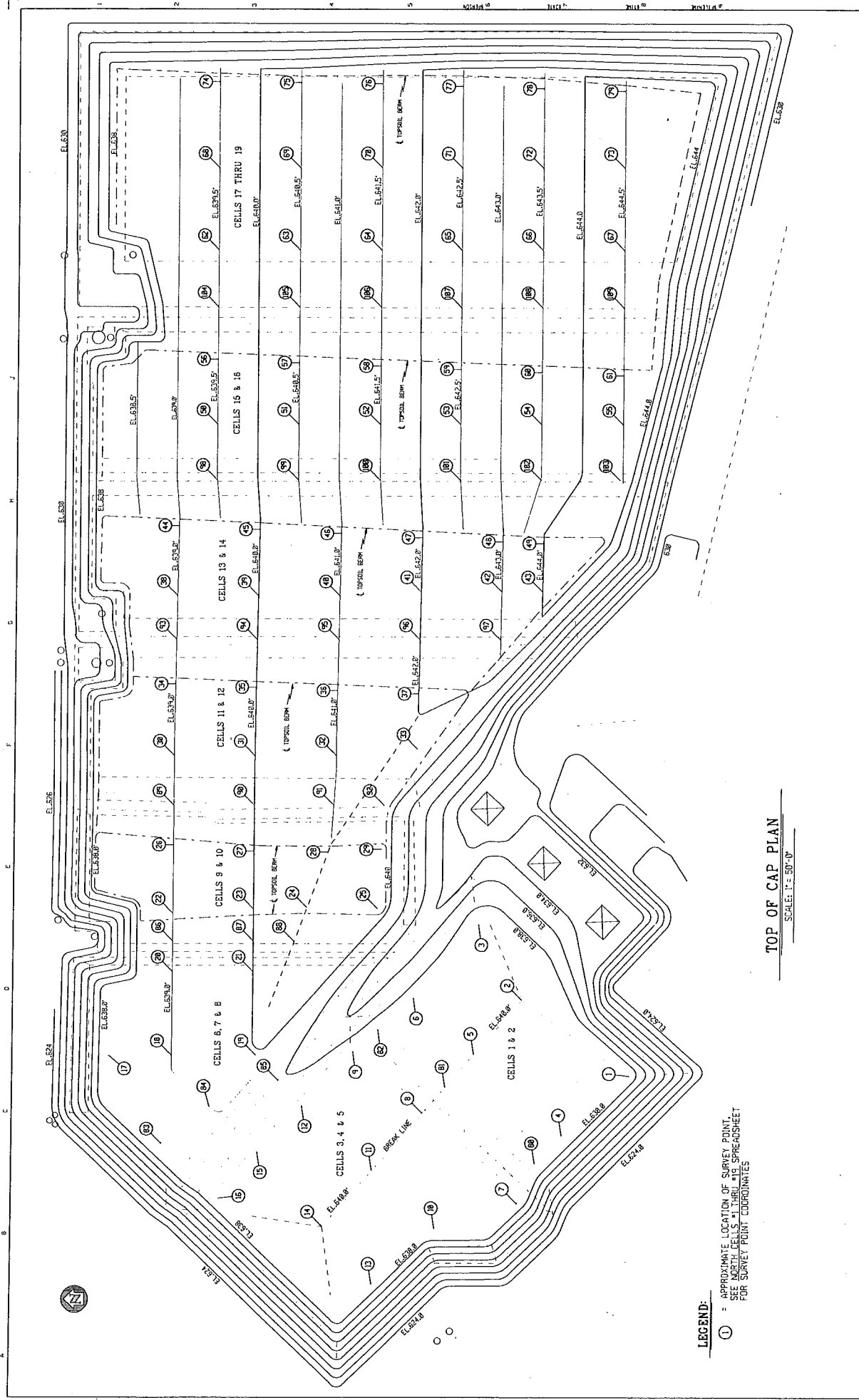

TOP OF CAP PLAN
SCALE: 1" = 50'-0"

LEGEND:
 (1) = APPROXIMATE LOCATION OF SURVEY POINT
 SEE NORTH CELLS #1 THRU #19 SPREADSHEET
 FOR SURVEY POINT COORDINATES

REVISION DATE BY CHECKED BY		REVISION DATE BY CHECKED BY		REVISION DATE BY CHECKED BY		REVISION DATE BY CHECKED BY		REVISION DATE BY CHECKED BY		REVISION DATE BY CHECKED BY		REVISION DATE BY CHECKED BY		REVISION DATE BY CHECKED BY	
DRAWING ISSUE RECORD															
PROJECT NO.		7/2/78		PERIOD		7/2/78		7/2/78		7/2/78		7/2/78		7/2/78	
THE DOW CHEMICAL COMPANY CHEMICAL OPERATIONS SHELBORNE TOWNSHIP WILMINGTON, OHIO 45395 CAP ELEVATION SURVEY PLAN NORTH CELLS #1 THRU #19 1" = 50'-0"															
PLAN															

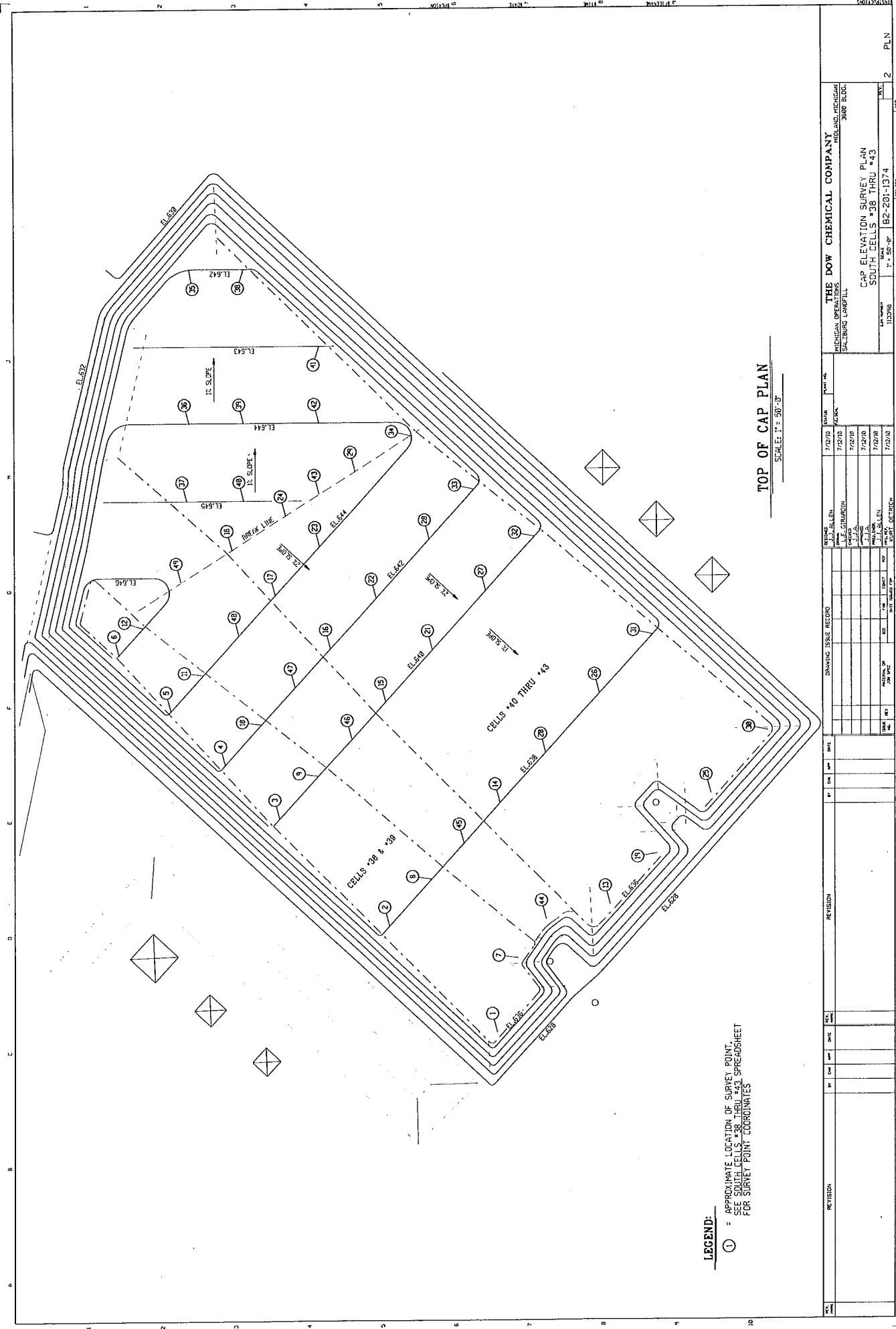

LEGEND:

① = APPROXIMATE LOCATION OF SURVEY POINT.
 SEE SOUTH CELLS #38 THRU #43 SPREADSHEET
 FOR SURVEY POINT COORDINATES

TOP OF CAP PLAN
 SCALE: 1" = 50'-0"

REV.	DATE	BY	CHK.	DATE	REVISION	DRAWING ISSUE RECORD	ISSUED	BY	DATE	FILE NO.	PLANT NO.
1	7/2/00	J.J. SALEN							7/2/00	4242	
2	7/2/00	J.J. SALEN							7/2/00		
3	7/2/00	J.J. SALEN							7/2/00		
4	7/2/00	J.J. SALEN							7/2/00		
5	7/2/00	J.J. SALEN							7/2/00		
6	7/2/00	J.J. SALEN							7/2/00		

THE DOW CHEMICAL COMPANY
 CHEMICAL OPERATIONS
 SCLABURG LANDFILL
 SCLABURG, PENNSYLVANIA 15098
 3600 BLDG.
CAP ELEVATION SURVEY PLAN
 SOUTH CELLS #38 THRU #43
 82-201-1374
 1" = 50'-0"
 2

SALZBURG LANDFILL CAP ELEVATION SURVEY

NORTH CELLS #1 THRU #19

(DATE) SURVEY vs DESIGN TOP OF CAP ELEVATION

SURVEY POINT NUMBERS ¹	EAST COORDINATE	SOUTH COORDINATE	DISTANCE TO PREVIOUS POINT (FEET)	(DATE) SURVEY ELEV (FEET)	DESIGN ELEV ² (FEET)	Δ ELEV ³ (FEET)	DESIGN SLOPE TO PREVIOUS POINT ⁴ (%)	CURRENT SLOPE TO PREVIOUS POINT (%)	Δ SLOPE (%)
1	E.6899	S.7114	N/A		638.1		N/A	N/A	N/A
2	E.6992	S.6982	162		640.0		1.2	N/A	
3	E.7085	S.6928	N/A		638.1		N/A	N/A	N/A
*2	E.6992	S.6982	107		640.0		1.8		
4	E.6826	S.7032	N/A		638.1		N/A	N/A	N/A
5	E.6926	S.6923	148		640.0		1.3		
6	E.6995	S.6847	N/A		638.1		N/A	N/A	N/A
*5	E.6926	S.6923	103		640.0		1.8		
7	E.6742	S.6978	N/A		638.1		N/A	N/A	N/A
8	E.6853	S.6860	162		640.0		1.2		
9	E.6930	S.6773	N/A		638.1		N/A	N/A	N/A
*8	E.6853	S.6860	115		640.0		1.6		
10	E.6712	S.6876	N/A		638.1		N/A	N/A	N/A
11	E.6783	S.6798	106		640.0		1.8		
12	E.6863	S.6711	N/A		638.4		N/A	N/A	N/A
*11	E.6783	S.6798	118		640.0		1.4		
13	E.6643	S.6799	N/A		638.1		N/A	N/A	N/A
14	E.6714	S.6737	94		640.0		2.0		
15	E.6807	S.6657	N/A		639.3		N/A	N/A	N/A
*14	E.6714	S.6737	122		640.0		0.6		
16	E.6749	S.6609	N/A		638.1		N/A	N/A	N/A
*15	E.6807	S.6657	75		639.3		1.6		
17	E.6924	S.6472	N/A		638.1		N/A	N/A	N/A
18	E.6924	S.6550	104		639.0		0.9		
19	E.6924	S.6654	104		640.0		1.0		
20	E.7027	S.6550	N/A		639.0		N/A	N/A	N/A
21	E.7027	S.6650	100		640.0		1.0		
22	E.7098	S.6550	N/A		639.0		N/A	N/A	N/A
23	E.7104	S.6650	100		640.0		1.0		
24	E.7106	S.6715	65		640.6		0.9		
25	E.7104	S.6802	87		640.1		0.6		
26	E.7183	S.6550	N/A		639.0		N/A	N/A	N/A
27	E.7175	S.6650	100		640.0		1.0		
28	E.7174	S.6740	90		640.9		1.0		
29	E.7177	S.6806	65		640.1		1.2		
30	E.7292	S.6550	N/A		639.0		N/A	N/A	N/A
31	E.7292	S.6650	100		640.0		1.0		
32	E.7106	S.6750	100		640.6		0.6		
33	E.7301	S.6850	100		641.4		0.8		
34	E.7381	S.6551	N/A		639.0		N/A	N/A	N/A
35	E.7377	S.6651	100		640.0		1.0		
36	E.7373	S.6751	100		640.9		0.9		
37	E.7369	S.6851	100		642.0		1.1		
38	E.7489	S.6553	N/A		639.0		N/A	N/A	N/A
39	E.7489	S.6653	100		640.0		1.0		
40	E.7489	S.6753	100		641.0		1.0		
41	E.7394	S.6853	100		642.0		1.0		
42	E.7494	S.6953	100		643.0		1.0		
43	E.7494	S.7003	50		644.0		2.0		
44	E.7575	S.6554	N/A		639.0		N/A	N/A	N/A
45	E.7571	S.6654	100		640.0		1.0		
46	E.7566	S.6754	100		641.0		1.0		

NOTES:

1. POINT NUMBERS are shown on Drawings B2-200-1374. Also an * indicates points that are duplicated in the table because the grade slopes away from that point in two directions.
2. DESIGN ELEVATION indicates the original design elevation for the surface of the topsoil layer at that point on the cap.
3. A negative number for Δ ELEV indicates the SURVEY elevation is lower than the PLAN elevation.
A positive number for Δ ELEV indicates the SURVEY elevation is higher than the PLAN elevation.
4. N/A in this column indicates a slope calculation between this point and the previous point is not applicable.

SALZBURG LANDFILL CAP ELEVATION SURVEY									
NORTH CELLS #1 THRU #19									
(DATE) SURVEY vs DESIGN TOP OF CAP ELEVATION									
SURVEY POINT NUMBERS ¹	EAST COORDINATE	SOUTH COORDINATE	DISTANCE TO PREVIOUS POINT (FEET)	(DATE) SURVEY ELEV (FEET)	DESIGN ELEV ² (FEET)	Δ ELEV ³ (FEET)	DESIGN SLOPE TO PREVIOUS POINT ⁴ (%)	CURRENT SLOPE TO PREVIOUS POINT (%)	Δ SLOPE (%)
47	E.7561	S.6854	100		642.0		1.0		
48	E.7556	S.6954	100		643.0		1.0		
49	E.7554	S.7004	50		644.0		2.0		
50	E.7699	S.6600	N/A		639.5		N/A	N/A	N/A
51	E.7699	S.6700	100		640.5		1.0		
52	E.7699	S.6800	100		641.5		1.0		
53	E.7699	S.6900	100		642.5		1.0		
54	E.7699	S.7000	100		643.5		1.0		
55	E.7699	S.7100	100		644.5		1.0		
56	E.7779	S.6600	N/A		639.5		N/A	N/A	N/A
57	E.7775	S.6700	100		640.5		1.0		
58	E.7771	S.6800	100		641.5		1.0		
59	E.7767	S.6900	100		642.5		1.0		
60	E.7763	S.7000	100		643.5		1.0		
61	E.7760	S.7100	100		644.5		1.0		
62	E.7912	S.6600	N/A		639.5		N/A	N/A	N/A
63	E.7912	S.6700	100		640.5		1.0		
64	E.7912	S.6800	100		641.5		1.0		
65	E.7912	S.6900	100		642.5		1.0		
66	E.7912	S.7000	100		643.5		1.0		
67	E.7912	S.7100	100		644.5		1.0		
68	E.8012	S.6600	N/A		639.5		N/A	N/A	N/A
69	E.8012	S.6700	100		640.5		1.0		
70	E.8012	S.6800	100		641.5		1.0		
71	E.8012	S.6900	100		642.5		1.0		
72	E.8012	S.7000	100		643.5		1.0		
73	E.8012	S.7100	100		644.5		1.0		
74	E.8117	S.6600	N/A		639.5		N/A	N/A	N/A
75	E.8116	S.6700	100		640.5		1.0		
76	E.8115	S.6800	100		641.5		1.0		
77	E.8112	S.6900	100		642.5		1.0		
78	E.8109	S.7000	100		643.5		1.0		
79	E.8106	S.7100	100		644.5		1.0		
80	E.6791	S.6999	N/A		638.1		N/A	N/A	N/A
81	E.6885	S.6888	146		640.0		1.3		
82	E.6956	S.6803	N/A		638.1		N/A	N/A	N/A
*81	E.6885	S.6888	110		640.0		1.7		
83	E.6816	S.6538	N/A		638.1		N/A	N/A	N/A
84	E.6861	S.6598	75		639.0		1.2		
85	E.6893	S.6682	91		639.0		0.0		
86	E.7064	S.6550	N/A		639.0		N/A	N/A	N/A
87	E.7064	S.6650	100		640.0		1.0		
88	E.7064	S.6700	50		640.5		1.0		
89	E.7231	S.6550	N/A		639.0		N/A	N/A	N/A
90	E.7231	S.6650	100		640.0		1.0		
91	E.7231	S.6747	97		641.0		1.0		
92	E.7231	S.6809	N/A		640.5		N/A	N/A	N/A
93	E.7435	S.6552	N/A		639.0		N/A	N/A	N/A
94	E.7435	S.6652	100		640.0		1.0		
95	E.7435	S.6752	100		641.0		1.0		
96	E.7435	S.6852	100		642.0		1.0		
97	E.7435	S.6952	100		643.0		1.0		
NOTES:									
1. POINT NUMBERS are shown on Drawings B2-200-1374. Also an * indicates points that are duplicated in the table because the grade slopes away from that point in two directions.									
2. DESIGN ELEVATION indicates the original design elevation for the surface of the topsoil layer at that point on the cap.									
3. A negative number for Δ ELEV indicates the SURVEY elevation is lower than the PLAN elevation. A positive number for Δ ELEV indicates the SURVEY elevation is higher than the PLAN elevation.									
4. N/A in this column indicates a slope calculation between this point and the previous point is not applicable.									

SALZBURG LANDFILL CAP ELEVATION SURVEY

NORTH CELLS #1 THRU #19

(DATE) SURVEY vs DESIGN TOP OF CAP ELEVATION

SURVEY POINT NUMBERS ¹	EAST COORDINATE	SOUTH COORDINATE	DISTANCE TO PREVIOUS POINT (FEET)	(DATE) SURVEY ELEV (FEET)	DESIGN ELEV ² (FEET)	Δ ELEV ³ (FEET)	DESIGN SLOPE TO PREVIOUS POINT ⁴ (%)	CURRENT SLOPE TO PREVIOUS POINT (%)	Δ SLOPE (%)
98	E.7631	S.6600	N/A		639.5		N/A	N/A	N/A
99	E.7631	S.6700	100		640.5		1.0		
100	E.7631	S.6800	100		641.5		1.0		
101	E.7631	S.6900	100		642.5		1.0		
102	E.7631	S.7000	100		643.5		1.0		
103	E.7631	S.7097	96		644.5		1.0		
104	E.7842	S.6600	N/A		639.5		N/A	N/A	N/A
105	E.7842	S.6700	100		640.5		1.0		
106	E.7842	S.6800	100		641.5		1.0		
107	E.7842	S.6900	100		642.5		1.0		
108	E.7842	S.7000	100		643.5		1.0		
109	E.7842	S.7100	100		644.5		1.0		

NOTES:

1. POINT NUMBERS are shown on Drawings B2-200-1374 & B2-201-1374. Also an * indicates points that are duplicated in the table because the grade slopes away from that point in two directions.
2. DESIGN ELEVATION indicates the original design elevation for the surface of the topsoil layer at that point on the cap.
3. A negative number for Δ ELEV indicates the SURVEY elevation is lower than the PLAN elevation.
A positive number for Δ ELEV indicates the SURVEY elevation is higher than the PLAN elevation.
4. N/A in this column indicates a slope calculation between this point and the previous point is not applicable.

SALZBURG LANDFILL CAP ELEVATION SURVEY

SOUTH CELLS #38 THRU #43

(DATE) SURVEY vs DESIGN ELEVATION

SURVEY POINT NUMBER ¹	EAST COORDINATE	SOUTH COORDINATE	DISTANCE TO PREVIOUS POINT (FEET)	(DATE) SURVEY ELEV (FEET)	DESIGN ELEV ² (FEET)	Δ ELEV ³ (FEET)	DESIGN SLOPE TO PREVIOUS POINT ⁴ (%)	CURRENT SLOPE TO PREVIOUS POINT (%)	Δ SLOPE (%)
1	E.7736	S.7964	N/A		636.1		N/A	N/A	N/A
2	E.7875	S.7823	191		638.0		1.0		
3	E.8015	S.7680	200		640.0		1.0		
4	E.8085	S.7609	100		642.0		2.0		
5	E.8156	S.7538	100		644.0		2.0		
6	E.8229	S.7470	100		646.0		2.0		
7	E.7833	S.7992	N/A		636.5		N/A	N/A	N/A
8	E.7936	S.7879	153		638.0		1.0		
9	E.8070	S.7731	200		640.0		1.0		
10	E.8138	S.7657	100		642.0		2.0		
11	E.8202	S.7581	100		644.0		2.0		
12	E.8264	S.7502	100		646.0		2.0		
13	E.7901	S.8112	N/A		636.1		N/A	N/A	N/A
14	E.8034	S.7968	195		638.0		1.0		
15	E.8167	S.7818	200		640.0		1.0		
16	E.8236	S.7747	100		642.0		2.0		
17	E.8306	S.7675	100		644.0		2.0		
18	E.8365	S.7618	82		645.6		1.9		
19	E.7968	S.8172	N/A		636.1		N/A	N/A	N/A
20	E.8100	S.8028	196		638.0		1.0		
21	E.8234	S.7880	200		640.0		1.0		
22	E.8302	S.7806	100		642.0		2.0		
23	E.8370	S.7733	100		644.0		2.0		
24	E.8410	S.7688	60		645.2		2.0		
25	E.8045	S.8243	N/A		636.1		N/A	N/A	N/A
26	E.8177	S.8098	196		638.0		1.0		
27	E.8311	S.7950	200		640.0		1.0		
28	E.8378	S.7876	100		642.0		2.0		
29	E.8467	S.7779	131		644.6		2.0		
30	E.8127	S.8318	N/A		636.1		N/A	N/A	N/A
31	E.8253	S.8167	197		638.0		1.0		
32	E.8381	S.8013	200		640.0		1.0		
33	E.8443	S.7934	100		642.0		2.0		
34	E.8513	S.7852	108		644.0		1.8		
35	E.8729	S.7563	N/A		642.0		N/A	N/A	N/A
36	E.8529	S.7563	200		644.0		1.0		
37	E.8429	S.7559	100		645.0		2.0		
38	E.8729	S.7634	N/A		642.0		N/A	N/A	N/A
39	E.8529	S.7634	200		644.0		1.0		
40	E.8429	S.7634	100		645.0		1.0		
41	E.8629	S.7732	N/A		643.0		N/A	N/A	N/A
42	E.8529	S.7732	100		644.0		1.0		
43	E.8437	S.7732	92		644.9		1.0		
44	E.7882	S.8028	N/A		636.5		N/A	N/A	N/A
45	E.7982	S.7921	147		638.0		1.0		
46	E.8118	S.7774	200		640.0		1.0		
47	E.8186	S.7701	100		642.0		2.0		
48	E.8254	S.7627	100		644.0		2.0		
49	E.8323	S.7551	103		646.1		2.0		

NOTES:

1. POINT NUMBERS are shown on Drawings B2-201-1374. Also an * indicates points that are duplicated in the table because the grade slopes away from that point in two directions.
2. DESIGN ELEVATION indicates the original design elevation for the surface of the topsoil layer at that point on the cap.
3. A negative number for Δ ELEV indicates the SURVEY elevation is lower than the PLAN elevation.
A positive number for Δ ELEV indicates the SURVEY elevation is higher than the PLAN elevation.
4. N/A in this column indicates a slope calculation between this point and the previous point is not applicable.

LEGEND:

① = APPROXIMATE LOCATION OF SURVEY POINT

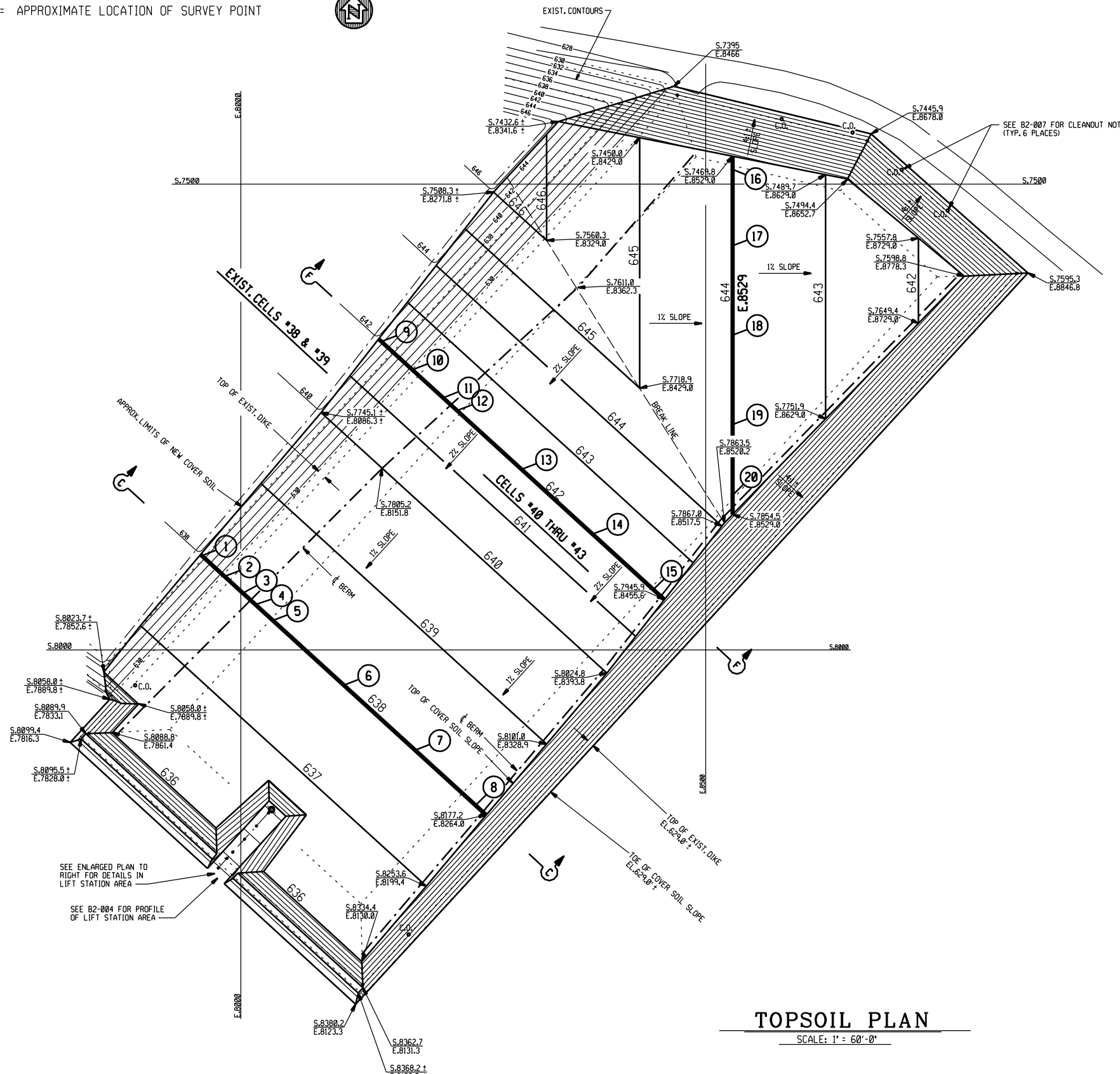

CELLS 40 thru 43 - SURVEY vs PLAN TOPSOIL ELEVATION 8/18/08

POINT NUMBER	SURVEY ELEV	PLAN ELEV	Δ ELEV ¹	CROSS SECTION	EAST COORDINATE	SOUTH COORDINATE
1	638.0	638.0	0.0	C-C	E.7957	S.7899
2	637.8	638.0	-0.2	C-C	E.7982	S.7921
3	637.8	638.0	-0.2	C-C	E.8002	S.7939
4	638.0	638.0	0.0	C-C	E.8016	S.7951
5	637.9	638.0	-0.1	C-C	E.8034	S.7968
6	638.0	638.0	0.0	C-C	E.8111	S.8038
7	638.0	638.0	0.0	C-C	E.8187	S.8108
8	638.0	638.0	0.0	C-C	E.8252	S.8167
9	641.9	642.0	-0.1	F-F	E.8151	S.7669
10	642.0	642.0	0.0	F-F	E.8185	S.7699
11	641.9	642.0	-0.1	F-F	E.8218	S.7729
12	641.9	642.0	-0.1	F-F	E.8233	S.7743
13	642.0	642.0	0.0	F-F	E.8302	S.7806
14	642.0	642.0	0.0	F-F	E.8379	S.7876
15	641.8	642.0	-0.2	F-F	E.8444	S.7936
16	643.9	644.0	-0.1	E.8529	E.8529	S.7484
17	643.9	644.0	-0.1	E.8529	E.8529	S.7566
18	643.8	644.0	-0.2	E.8529	E.8529	S.7662
19	643.9	644.0	-0.1	E.8529	E.8529	S.7758
20	643.8	644.0	-0.2	E.8529	E.8529	S.7834

1. The negative number indicates the Survey elevation is lower than the Plan elevation.
A positive number indicates the Survey elevation is higher than the Plan elevation.

TOPSOIL PLAN
SCALE: 1" = 60'-0"

REV. MARK	REVISION	BY	CHK	APP	DATE	REV. MARK	REVISION	BY	CHK	APP	DATE	DRAWING ISSUE RECORD		DESIGNED	9/08	STATUS	PLANT NO.	THE DOW CHEMICAL COMPANY		
												ISSUE NO.	REV	MATERIAL OR JOB SPEC	BID	FAB	CONST	REF	MICHIGAN OPERATIONS SALZBURG LANDFILL 3600 BLDG.	
																			SURVEYED VS PLAN TOPSOIL ELEV. 8-18-08 CELLS 40 THRU 43	
																			EIN NUMBER 113262	
																			SCALE AS NOTED	
																			B2-100-853	
																			2 UND	

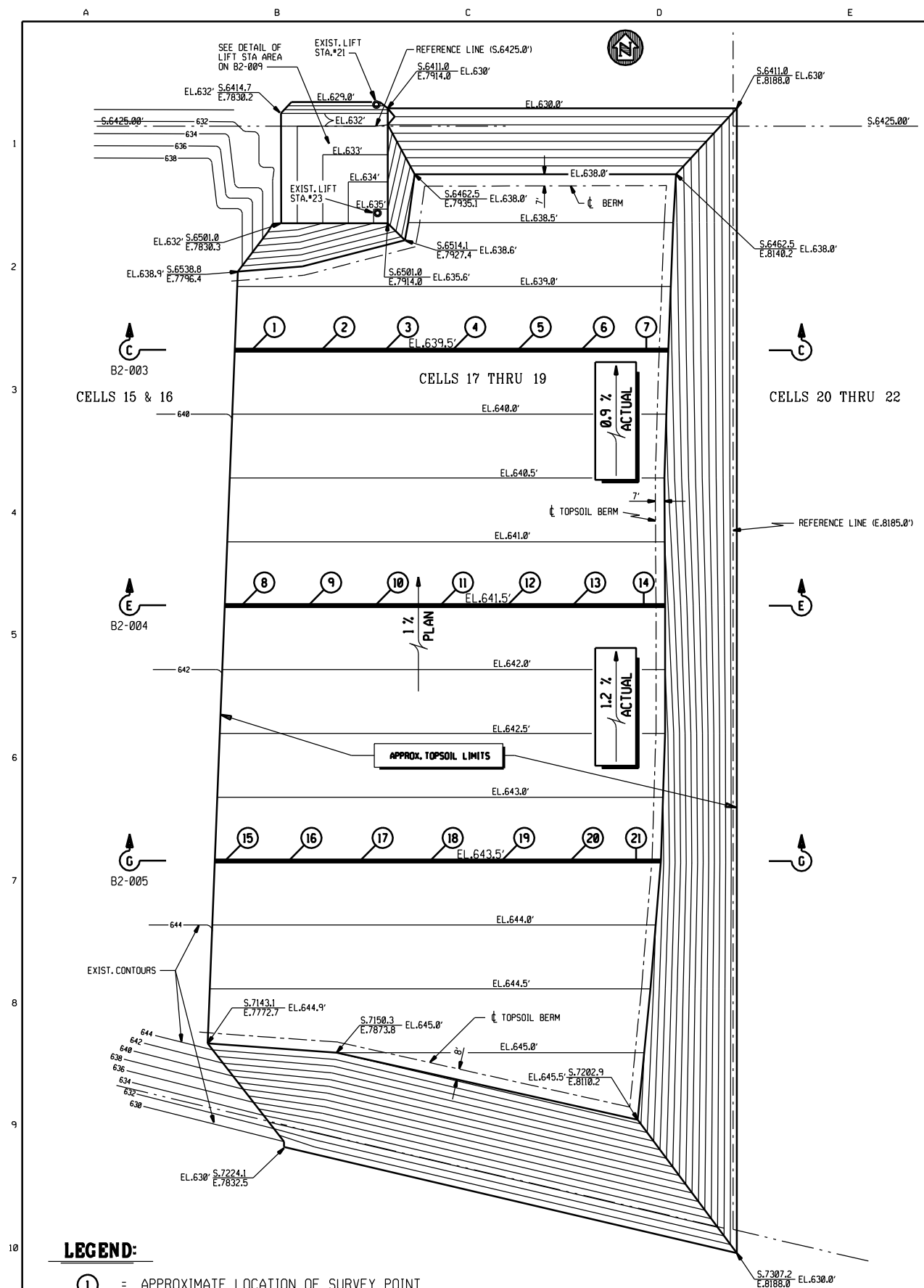

CELLS 17 thru 19 - SURVEY vs PLAN TOPSOIL ELEVATION 8/18/08

POINT NUMBER	SURVEY ELEV	PLAN ELEV	Δ ELEV ¹	CROSS SECTION	EAST COORDINATE	SOUTH COORDINATE
1	639.4	639.5	-0.1	C-C	E.7807	S.6600
2	639.5	639.5	0.0	C-C	E.7862	S.6600
3	639.6	639.5	0.1	C-C	E.7912	S.6600
4	639.6	639.5	0.1	C-C	E.7965	S.6600
5	639.3	639.5	-0.2	C-C	E.8016	S.6600
6	639.3	639.5	-0.2	C-C	E.8066	S.6600
7	639.2	639.5	-0.3	C-C	E.8117	S.6600
8	641.4	641.5	-0.1	E-E	E.7799	S.6800
9	641.4	641.5	-0.1	E-E	E.7852	S.6800
10	641.6	641.5	0.1	E-E	E.7904	S.6800
11	641.6	641.5	0.1	E-E	E.7955	S.6800
12	641.5	641.5	0.0	E-E	E.8008	S.6800
13	641.2	641.5	-0.3	E-E	E.8059	S.6800
14	641.0	641.5	-0.5	E-E	E.8115	S.6800
15	643.6	643.5	0.1	G-G	E.7786	S.7000
16	643.5	643.5	0.0	G-G	E.7836	S.7000
17	643.7	643.5	0.2	G-G	E.7892	S.7000
18	643.6	643.5	0.1	G-G	E.7947	S.7000
19	643.6	643.5	0.1	G-G	E.8003	S.7000
20	643.5	643.5	0.0	G-G	E.8057	S.7000
21	643.4	643.5	-0.1	G-G	E.8109	S.7000

1. The negative number indicates the Survey elevation is lower than the Plan elevation.
A positive number indicates the Survey elevation is higher than the Plan elevation.

LEGEND:

① = APPROXIMATE LOCATION OF SURVEY POINT

TOPSOIL PLAN

SCALE: 1" = 50'-0"

REV. MARK	REVISION	BY	CHK	APP	DATE	REV. MARK	REVISION	BY	CHK	APP	DATE	DRAWING ISSUE RECORD		DESIGNED J.J. ALLEN 9/08	STATUS	PLANT NO.	THE DOW CHEMICAL COMPANY MICHIGAN OPERATIONS SALZBURG LANDFILL MIDLAND, MICHIGAN 3600 BLDG.					
												ISSUE NO.	REV	MATERIAL OR JOB SPEC	BID	FAB	CONST	REF	CHECKED L.E. GIRARDIN 9/08 APPROVED J.J.A. 9/08 PROJ. ENGR. J.J. ALLEN 9/08 MFG. REP. KURT DETRICH 9/08	F.E. SEAL SCALE AS NOTED B2-100-854 VER. 2	SURVEYED VS PLAN TOPSOIL ELEV. 8-18-08 CELLS 17 THRU 19 E.I.N. NUMBER 113262 PRINTED VER.	2 UND

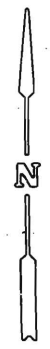
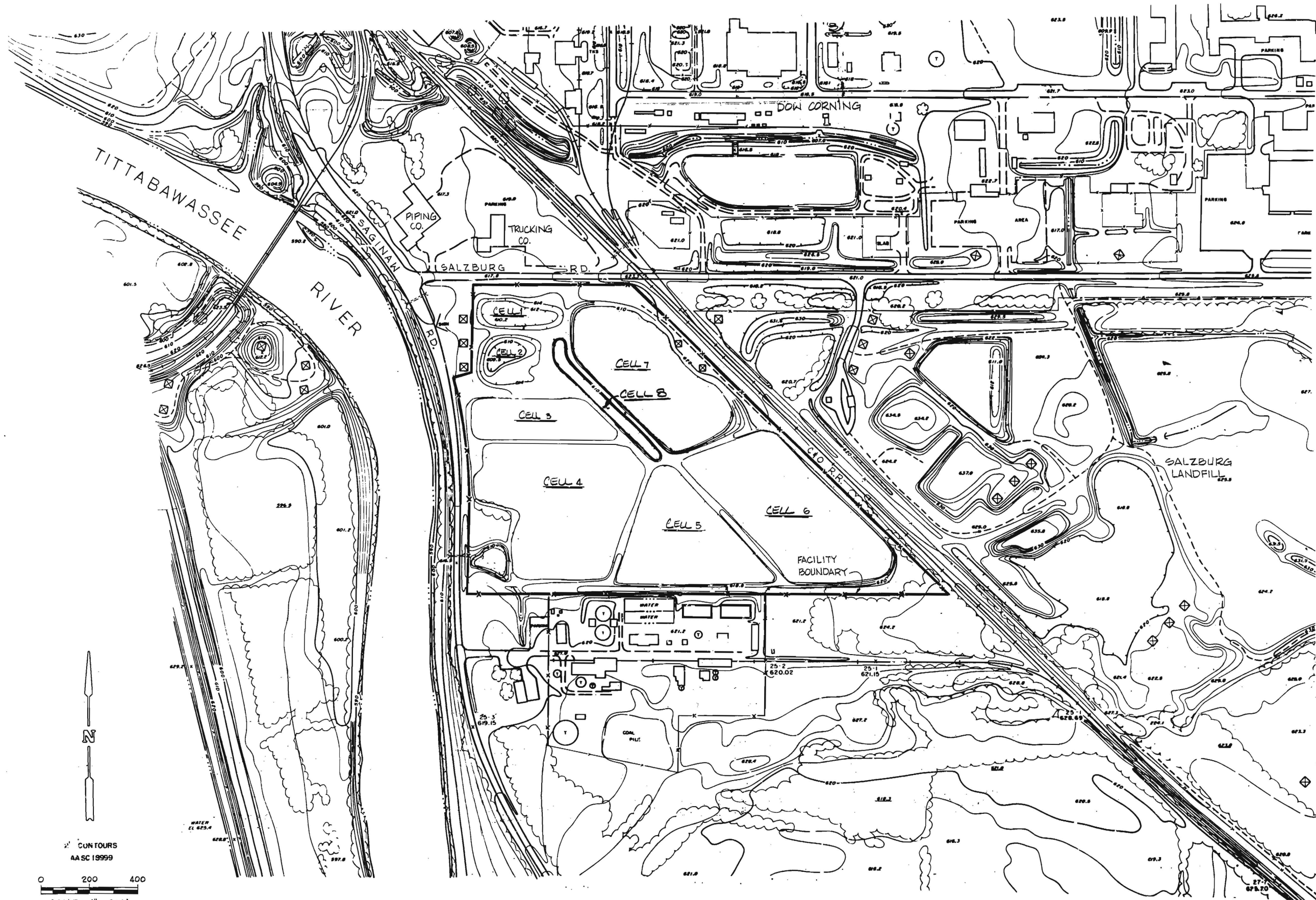

CONTOURS
 AASC 19999
 0 200 400
 SCALE: 1" = 200'
 X—X—X = FACILITY BOUNDARY

DESIGNED	DONOVAN/SCHULZE	9-28-86
DRAWN	WR. TRIPP	9-29-86
CHECKED	<i>[Signature]</i>	707
APPROVED	<i>[Signature]</i>	
PROJ ENGR		
MEG REP		

THE DOW CHEMICAL COMPANY MIDLAND DIVISION MIDLAND, MICHIGAN		
SLUDGE DEWATERING FACILITY		S D F
ORIGINAL SITE PLAN		
JOB NUMBER 874006	SCALE 1" = 200'	B2-100-874006

LEGEND:

① = APPROXIMATE LOCATION OF SURVEY POINT, SEE TABLE FOR SURVEY POINT COORDINATES

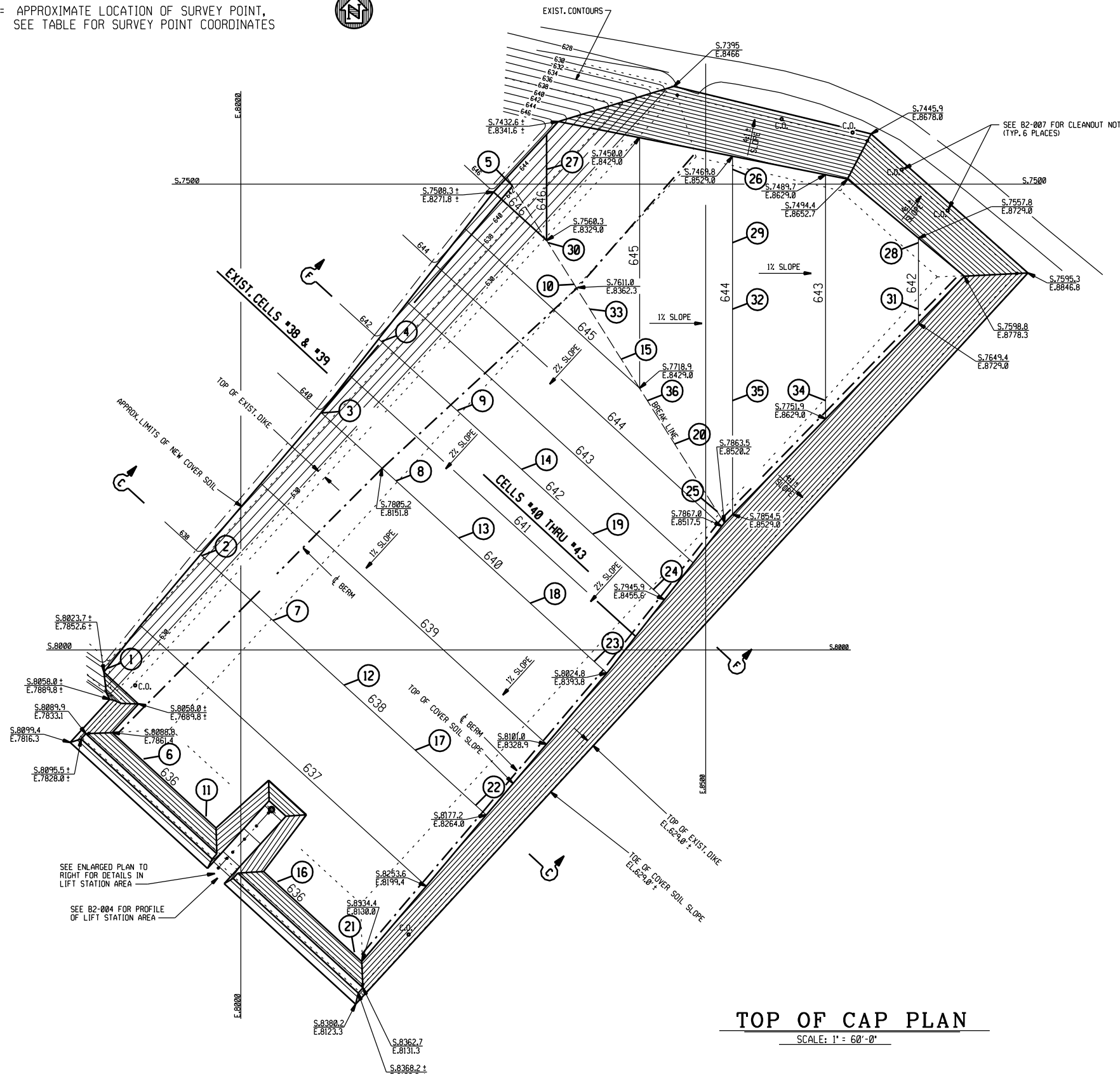

TOP OF CAP PLAN

SCALE: 1" = 60'-0"

SURVEY (DATE) vs ORIGINAL TOP OF CAP ELEVATION

POINT NUMBER	SURVEY ELEV (FEET)	PLAN ELEV (FEET)	Δ ELEV (FEET)	SLOPE TO PREVIOUS POINT (%)	EAST COORDINATE	SOUTH COORDINATE
1		636.4		N/A	E.7855	S.8020
2		638.0			E.7957	S.7899
3		640.0			E.8087	S.7746
4		642.0			E.8151	S.7669
5		646.4			E.8292	S.7502
6		636.0		N/A	E.7895	S.8117
7		638.0			E.8034	S.7968
8		640.0			E.8167	S.7818
9		642.0			E.8233	S.7743
10		645.7			E.8359	S.7607
11		636.0		N/A	E.7963	S.8179
12		638.0			E.8111	S.8038
13		640.0			E.8234	S.7880
14		642.0			E.8302	S.7806
15		645.2			E.8409	S.7688
16		636.0		N/A	E.8039	S.8249
17		638.0			E.8187	S.8108
18		640.0			E.8311	S.7950
19		642.0			E.8379	S.7876
20		644.6			E.8467	S.7779
21		636.0		N/A	E.8122	S.8325
22		638.0			E.8252	S.8167
23		640.0			E.8380	S.8012
24		642.0			E.8444	S.7936
25		644.2			E.8513	S.7852
26		644.0		N/A	E.8529	S.7484
27		646.0			E.8329	S.7484
28		642.0		N/A	E.8729	S.7563
29		644.0			E.8529	S.7563
30		646.0			E.8330	S.7563
31		642.0		N/A	E.8729	S.7634
32		644.0			E.8529	S.7634
33		645.5			E.8375	S.7634
34		643.0		N/A	E.8629	S.7732
35		644.0			E.8529	S.7732
36		644.9			E.8437	S.7732

- The negative number indicates the Survey elevation is lower than the Plan elevation. A positive number indicates the Survey elevation is higher than the Plan elevation.
- N/A indicates slope calculation between this point & previous point is not applicable.

REV. MARK	REVISION	BY	CHK	APP	DATE	REV. MARK	REVISION	BY	CHK	APP	DATE	ISSUE NO.	REV.	MATERIAL OR JOB SPEC.	BID	FAB	CONST	REF	DESIGNED	DATE	STATUS	PLANT NO.	THE DOW CHEMICAL COMPANY		VER.
																			J.J. ALLEN	10/08			MICHIGAN OPERATIONS SALZBURG LANDFILL		2
																			L.E. GIRARDIN	10/08			MIDLAND, MICHIGAN 3600 BLDG.		UND
																			J.J.A.	10/08			CAP ELEVATION SURVEY PLAN CELLS 40 THRU 43		
																			J.J.A.	10/08			SCALE AS NOTED		
																			J.J.A.	10/08			B2-200-853		
																			J.J. ALLEN	10/08			EJN NUMBER 114291		
																			KURT DETRICH	10/08			PRINTED		

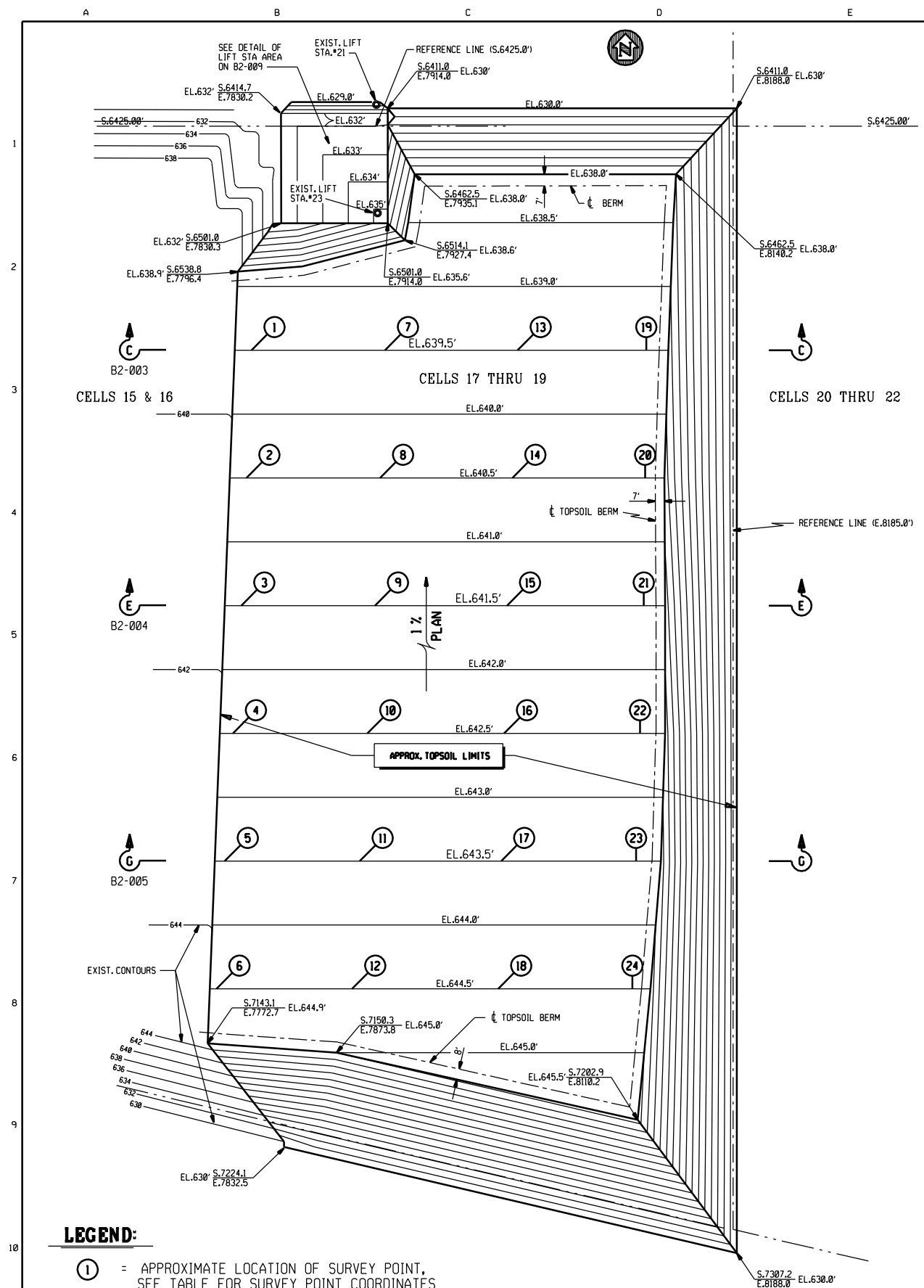

TOP OF CAP PLAN
 SCALE: 1" = 50'-0"

SURVEY (DATE) vs ORIGINAL TOP OF CAP ELEVATION

POINT NUMBER	SURVEY ELEV (FEET)	PLAN ELEV (FEET)	Δ ELEV ¹ (FEET)	SLOPE TO PREVIOUS POINT ² (%)	EAST COORDINATE	SOUTH COORDINATE
1		639.5		N/A	E.7807	S.6600
2		640.5			E.7803	S.6700
3		641.5			E.7799	S.6800
4		642.5			E.7793	S.6900
5		643.5			E.7786	S.7000
6		644.5			E.7780	S.7100
7		639.5		N/A	E.7912	S.6600
8		640.5			E.7908	S.6700
9		641.5			E.7904	S.6800
10		642.5			E.7898	S.6900
11		643.5			E.7892	S.7000
12		644.5			E.7886	S.7100
13		639.5		N/A	E.8016	S.6600
14		640.5			E.8012	S.6700
15		641.5			E.8008	S.6800
16		642.5			E.8005	S.6900
17		643.5			E.8003	S.7000
18		644.5			E.8001	S.7100
19		639.5		N/A	E.8117	S.6600
20		640.5			E.8116	S.6700
21		641.5			E.8115	S.6800
22		642.5			E.8112	S.6900
23		643.5			E.8109	S.7000
24		644.5			E.8106	S.7100

1. The negative number indicates the Survey elevation is lower than the Plan elevation.
 A positive number indicates the Survey elevation is higher than the Plan elevation.
 2. N/A indicates slope calculation between this point & previous point is not applicable.

REV. MARK	REVISION	BY	CHK	APP	DATE	REV. MARK	REVISION	BY	CHK	APP	DATE	DRAWING ISSUE RECORD		DESIGNED J.J. ALLEN 10/08	STATUS	PLANT NO.	THE DOW CHEMICAL COMPANY MICHIGAN OPERATIONS SALZBURG LANDFILL MIDLAND, MICHIGAN 3600 BLDG.						
												ISSUE NO.	REV	MATERIAL OR JOB SPEC	BID	FAB	CONST	REF	CHECKED J.J.A. APPROVED J.J.A. PROJ. ENGR. J.J. ALLEN MFG. REP. KURT DETRICH	SCALE AS NOTED B2-200-854	REV.	2	UND

DATE OF REVISION

REVISIONS

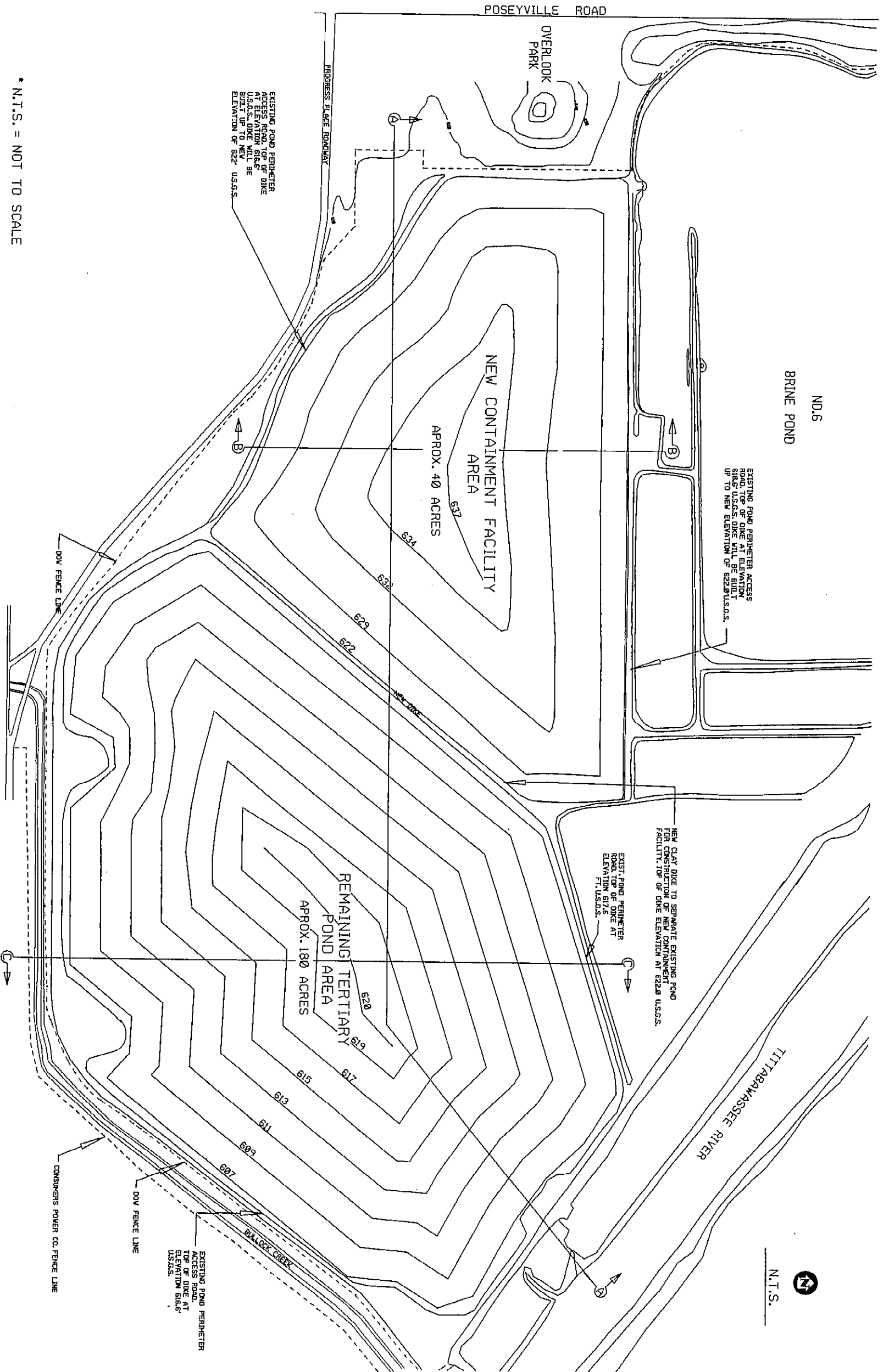

* N.T.S. = NOT TO SCALE

CONCEPTUAL

REV.	REVISION	BY	CHK	APP	DATE	REV.	BY	CHK	APP	DATE	DRINKING ISSUE RECORD	DESIGNED	DATE	STATUS	DATE	PROJECT NUMBER	SCALE	AS NOTED	PROJECT NUMBER	SCALE	AS NOTED
A	CHANGED DWG. NO. B2-500-9741008 TO B2-500-927122 AND CONVERTED DRAWING TO MICRO-STATION	PHD	JB	JB	3/73							MAHLENNIS	01/87			B2-500-927122			B2-500-927122		
B	REVISED TITLE BLOCK	LEG	JJA	JJA	5/81							MAHLENNIS	02/73								
												MAHLENNIS	02/73								

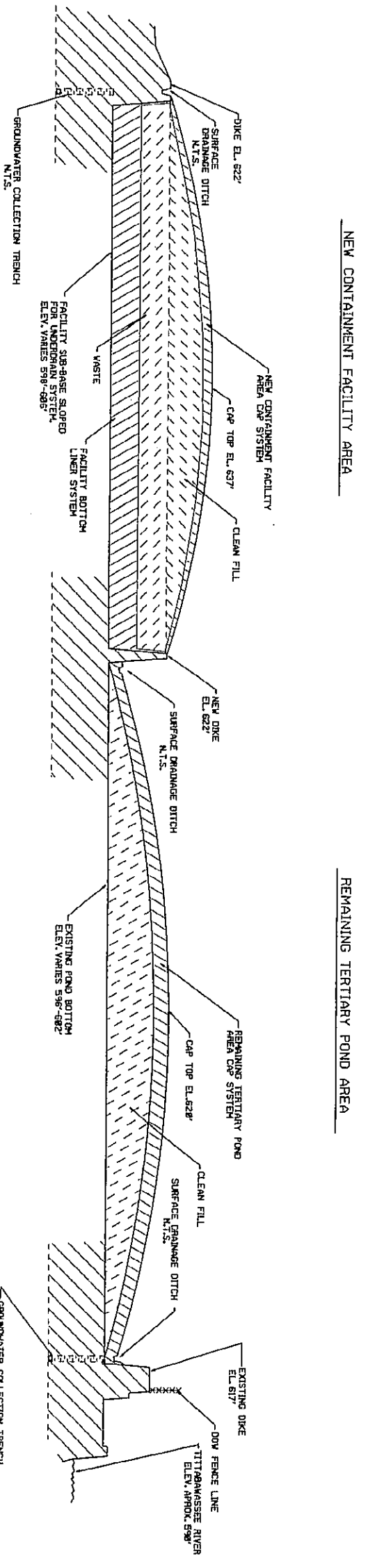

SECTION "A"
SCALE: N.T.S.

CONCEPTUAL

NOTE:
1. ALL ELEVATIONS ARE U.S.G.S. DATUM.
2. N.T.S. (NOT TO SCALE)

REV.	NO.	DATE	BY	CHK.	APP.	DATE	REV.	NO.	DATE	BY	CHK.	APP.	DATE	REV.	NO.	DATE	BY	CHK.	APP.	DATE	REV.	NO.	DATE	BY	CHK.	APP.	DATE
A	CHANGED DWG. NO. 82-501-927122 AND CONVERTED DRAWING TO MICRO-STATION REVISION TITLE BLOCK																										
B	REVISED TITLE BLOCK																										

REV.	NO.	DATE	BY	CHK.	APP.	DATE	REV.	NO.	DATE	BY	CHK.	APP.	DATE
1	1	1/13	JJA	JJA									
2	2	7/93	JJA	JJA									

NO.	DATE	BY	CHK.	APP.	DATE	NO.	DATE	BY	CHK.	APP.	DATE
1	1/13	JJA	JJA								
2	7/93	JJA	JJA								

NO.	DATE	BY	CHK.	APP.	DATE	NO.	DATE	BY	CHK.	APP.	DATE
1	1/13	JJA	JJA								
2	7/93	JJA	JJA								

NO.	DATE	BY	CHK.	APP.	DATE	NO.	DATE	BY	CHK.	APP.	DATE
1	1/13	JJA	JJA								
2	7/93	JJA	JJA								

THE DOW CHEMICAL COMPANY
MIDLAND, MICHIGAN
TERTIARY POND
T-POND CLOSURE PLAN - SECTION
FINAL CAPPING LAYOUT CROSS-SECTIONS
PROJECT NUMBER: 82-501-927122
SCALE: AS NOTED
SHEET: 2
UNDO

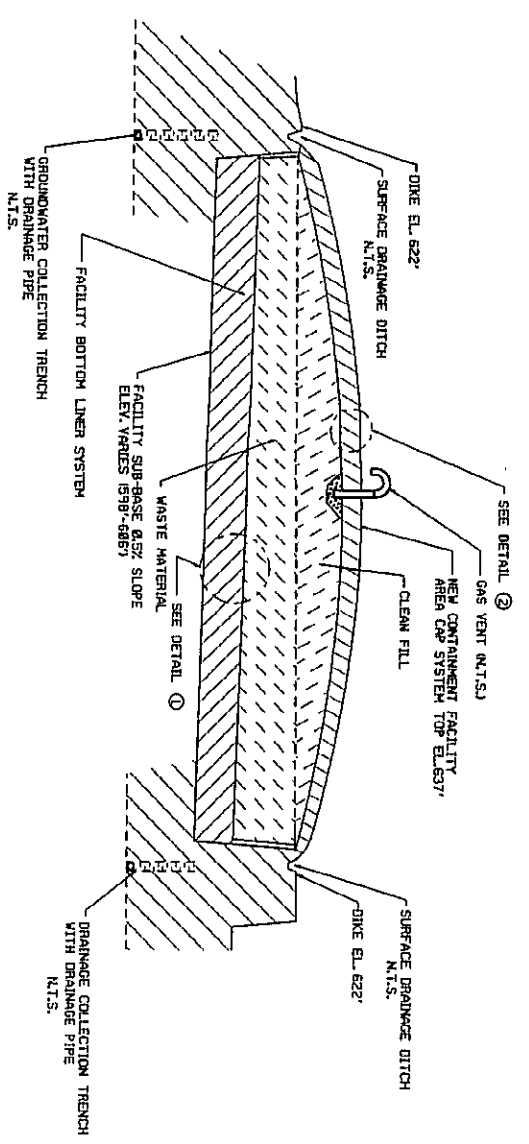

NEW CONTAINMENT FACILITY AREA

SECTION "B"
SCALE: N.T.S.

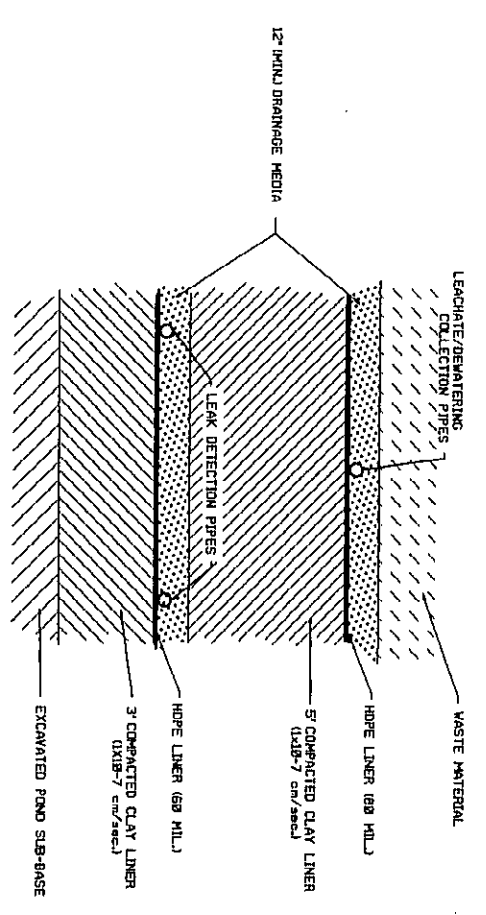

DETAIL 1
N.T.S.

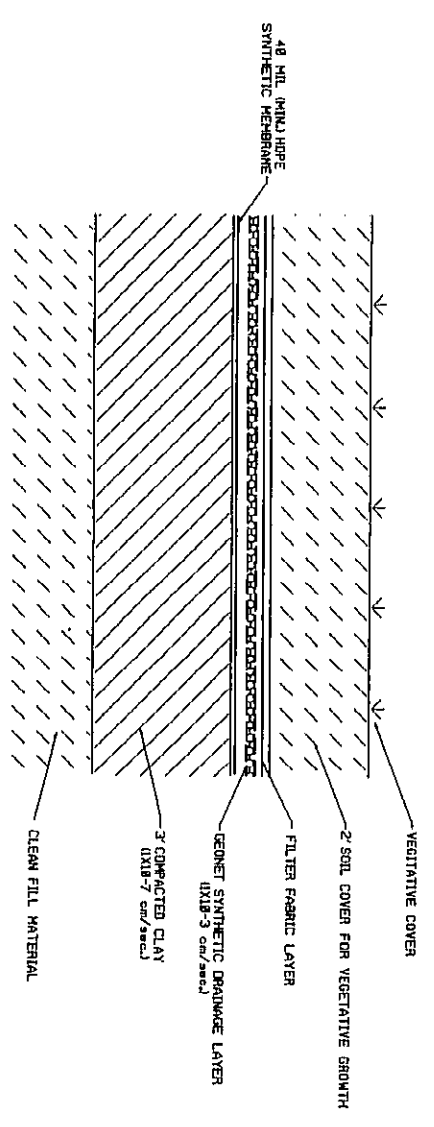

DETAIL 2
N.T.S.

NOTE:
1. ALL ELEVATIONS ARE U.S.G.S. DATUM.
2. N.T.S. (NOT TO SCALE)

CONCEPTUAL

REV.	REVISION	BY	CHK	APP	DATE	REV.	REVISION	BY	CHK	APP	DATE	DRAWING ISSUE RECORD		DESIGNED		CHECKED		DATE		PROJECT NUMBER		SCALE		SHEET	
A	CHANGED DWG. NO. B2-502-927122 AND CONVERTED DRAWING TO MICRO-STATION	RHD	JB	JJA	3/93										J.S. KONRICH	J.S. KONRICH					B2-502-927122	AS NOTED	B2-502-927122	8	2
B	REVISED TITLE BLOCK & REVISED DETAIL 1														J.S. KONRICH	J.S. KONRICH									

REMAINING TERTIARY POND AREA

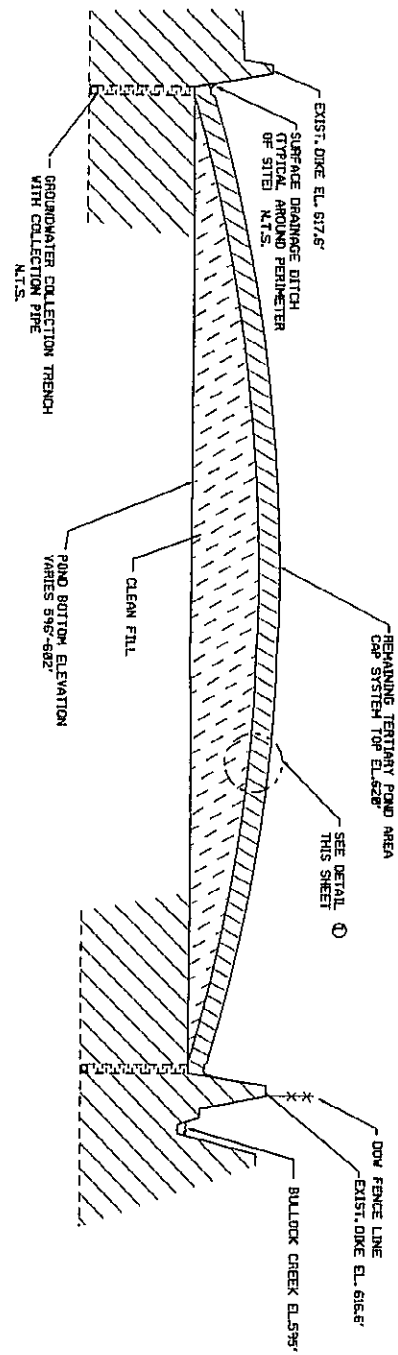

SECTION "C"
SCALE: N.T.S.

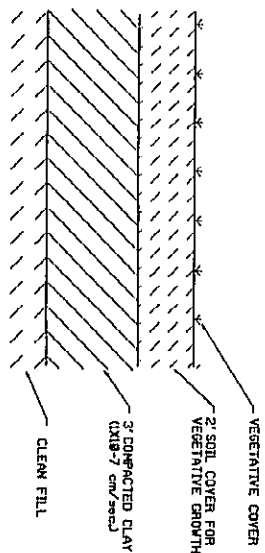

DETAIL ①
N.T.S.

NOTE:
1. ALL ELEVATIONS ARE U.S.G.S. DATUM.
2. N.T.S. (NOT TO SCALE)

CONCEPTUAL

REVISION				REVISION				REVISION				REVISION				REVISION				REVISION															
NO.	BY	CHK	DATE	NO.	BY	CHK	DATE	NO.	BY	CHK	DATE	NO.	BY	CHK	DATE	NO.	BY	CHK	DATE	NO.	BY	CHK	DATE	NO.	BY	CHK	DATE	NO.	BY	CHK	DATE	NO.	BY	CHK	DATE
CHANGED DWG. NO. B2-503-92122 TO B2-503-927122 AND CONVERTED TO MICRO-STATION LEG JJA/JJA																																			
REVISIONED TITLE BLOCK																																			

DRAWING ISSUE RECORD		ISSUED		STATUS		PART NO.	
NO.	DATE	NO.	DATE				
1	08/24/93	1	08/24/93	ISSUED			
2	08/24/93	2	08/24/93	ISSUED			
3	08/24/93	3	08/24/93	ISSUED			

THE DOW CHEMICAL COMPANY		MICHIGAN DIVISION		MIDLAND, MICHIGAN	
PROJECT NUMBER	SCALE	DATE	AS NOTED	PROJECT NUMBER	SCALE
927122		08/24/93		927122	

TERTIARY POND			
T-POND CLOSURE PLAN - SECTIONS			
FINAL CAPING LAYOUT CROSS-SECTIONS			
DATE PLOTTED	SCALE	AS NOTED	AS NOTED
08/24/93			
PROJECT NUMBER	SCALE	DATE	AS NOTED
927122		08/24/93	
PROJECT NUMBER	SCALE	DATE	AS NOTED
927122		08/24/93	
PROJECT NUMBER	SCALE	DATE	AS NOTED
927122		08/24/93	

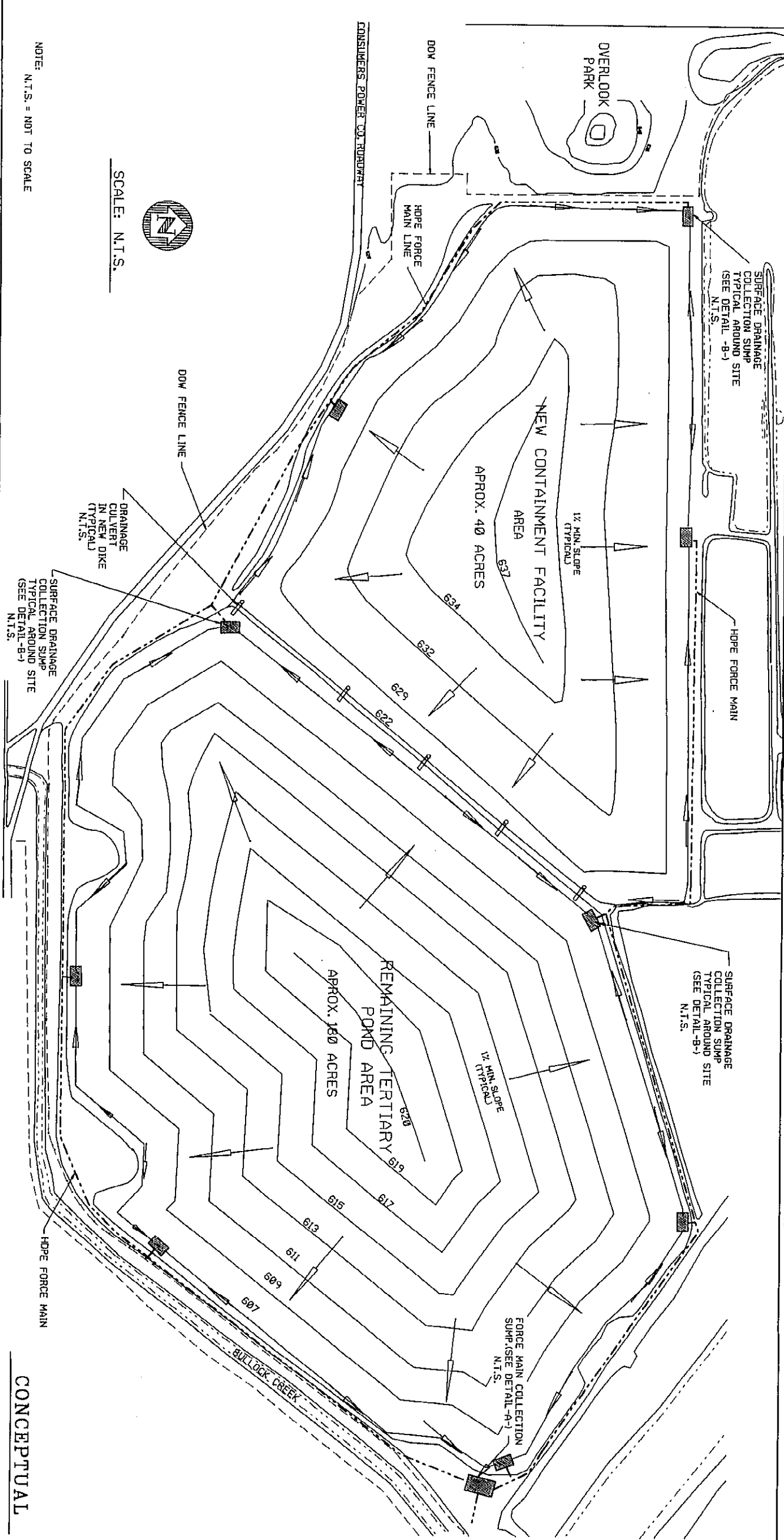
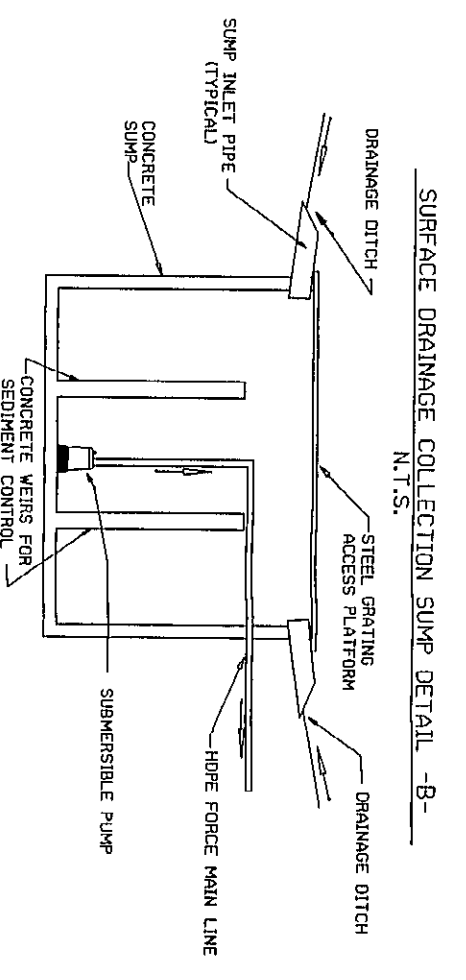
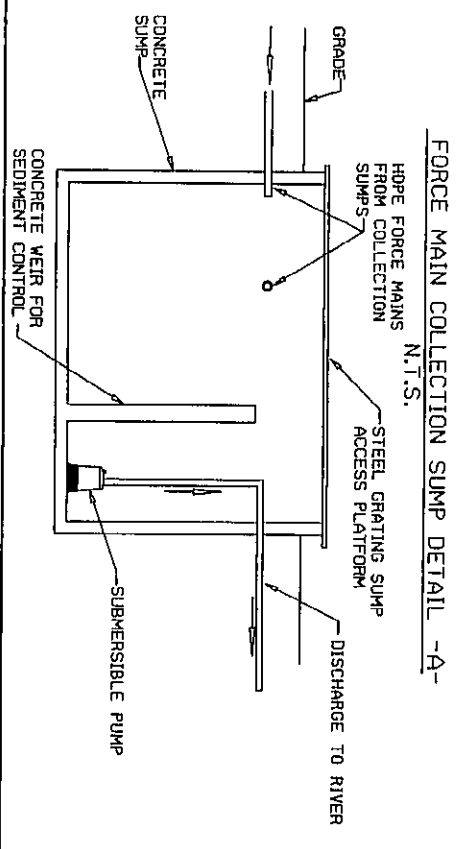

SCALE: N.T.S.

NOTE:
N.T.S. = NOT TO SCALE

REV.	DATE	BY	CHK.	APP.	DESCRIPTION
A	02/23/93	JJB	JJB	JJB	CHANGED DWS NO. 82-505-87488B TO 82-505-927122 AND CLOSING TO DRAINAGE TO HIGHWAY STATION
B	02/23/93	JJB	JJB	JJB	REVISED TITLE BLOCK

REV.	DATE	BY	CHK.	APP.	DESCRIPTION
1	01/97	R. BLANKENHORN			ISSUED
2	02/93	J. BENTLEY			REVISED
3	02/93	J. BENTLEY			REVISED

NO.	DATE	ISSUE	REVISION
1	01/97	ISSUE	
2	02/93	REVISED	
3	02/93	REVISED	

NO.	DATE	ISSUE	REVISION
1	01/97	ISSUE	
2	02/93	REVISED	
3	02/93	REVISED	

NO.	DATE	ISSUE	REVISION
1	01/97	ISSUE	
2	02/93	REVISED	
3	02/93	REVISED	

THE DOW CHEMICAL COMPANY
MIDLAND, MICHIGAN

TERTIARY POND
SURFACE DRAINAGE COLLECTION SYSTEM

PROJECT NO. 82-505-927122

DATE 02/93

AS NOTED

UNCL

NEW CONTAINMENT FACILITY
DEWATERING WEIR SYSTEM

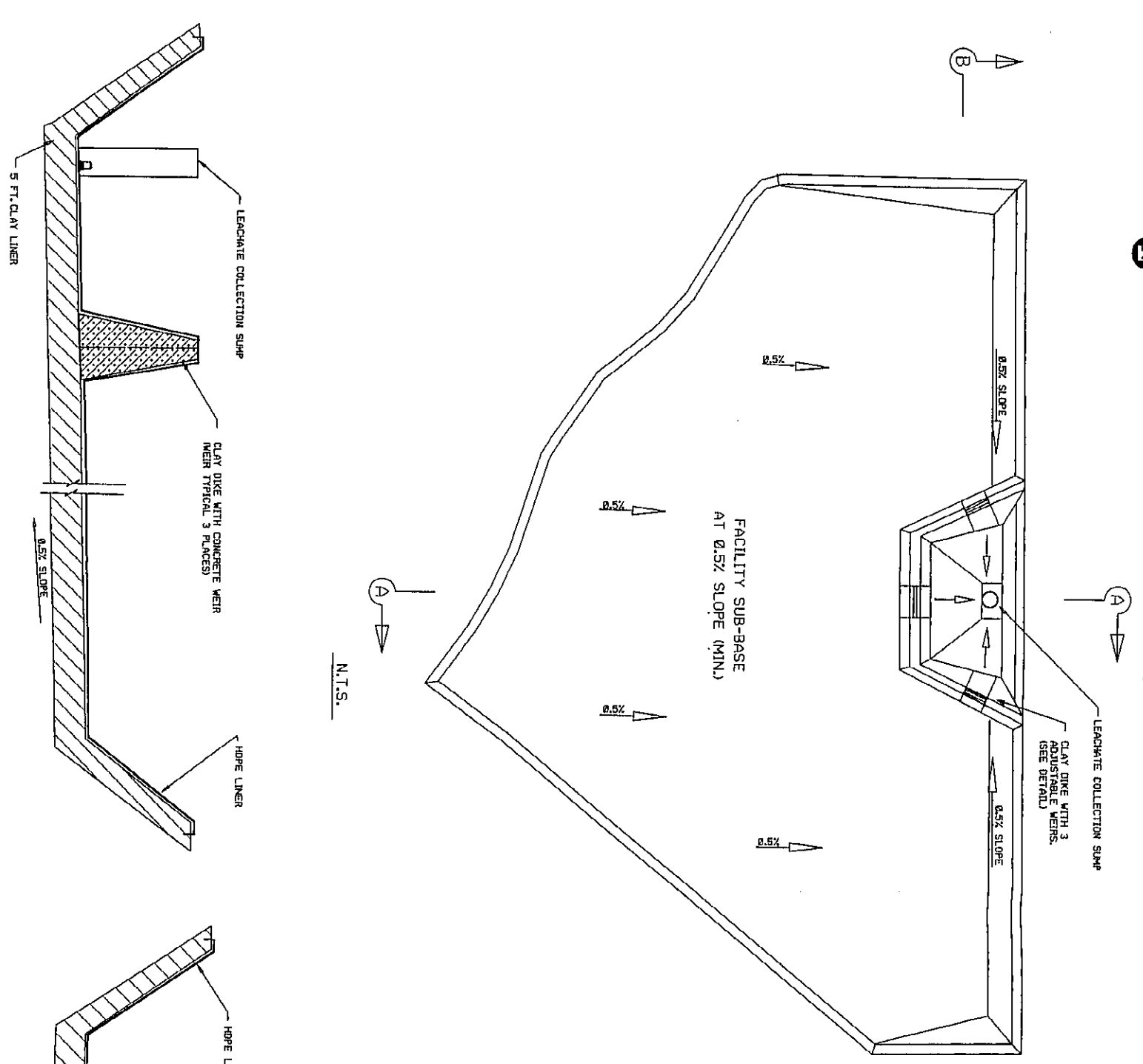

WEIR BOX DETAIL
N.T.S.

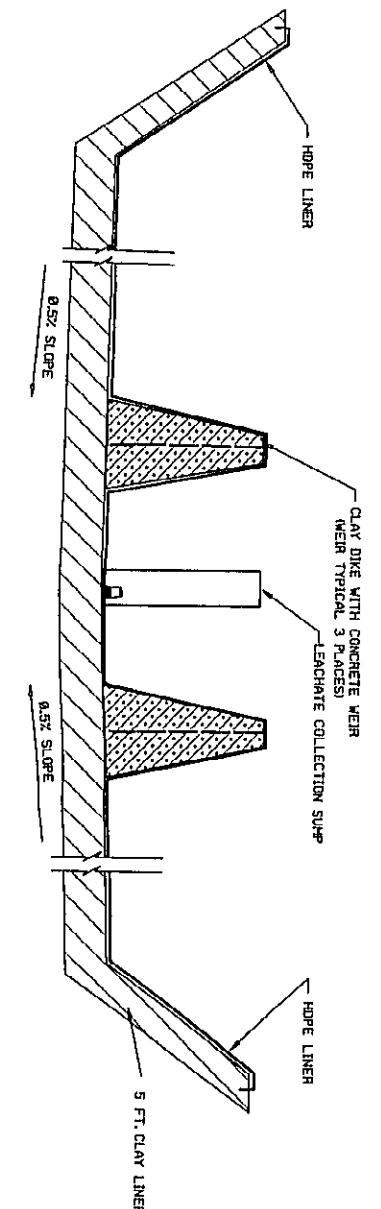
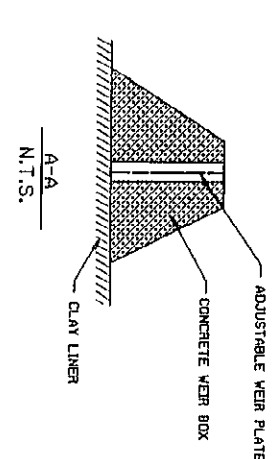
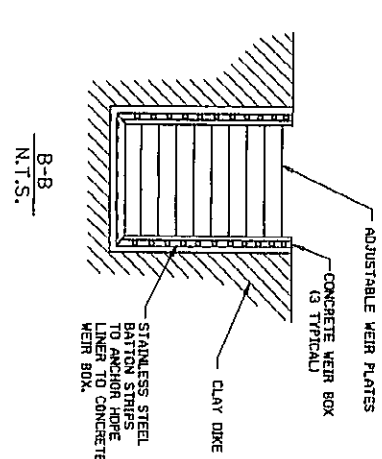
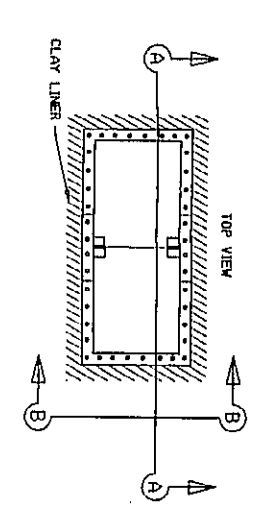

SECTION -A- N.T.S.

SECTION -B- N.T.S.

CONCEPTUAL

NOTE:
1. N.T.S. (NOT TO SCALE)

REV.	DESCRIPTION	DATE	BY	CHECKED	DATE	BY	CHECKED
A	CHANGED DWG. NO. B2-506-874808 TO B2-506-927122 AND CONVERTED DRAWING TO MICRO-STATION	3/93	RWD	JJA	3/93	JJA	JJA
B	REVISED TITLE BLOCK	9/91	JJA	JJA	9/91	JJA	JJA

THE DOW CHEMICAL COMPANY
MICHIGAN DIVISION
T-POND CLOSURE PLAN - WEIR PLAN
DEWATERING WEIR SYSTEM

PROJECT NUMBER: 927122
AS NOTED: B2-506-927122

DATE: 9/27/91
BY: JJA
CHECKED: JJA

SCALE: 1/8" = 1'-0"

UNDO

NEW CONTAINMENT FACILITY

LEAK DETECTION / LEACHATE COLLECTION PIPING SYSTEM

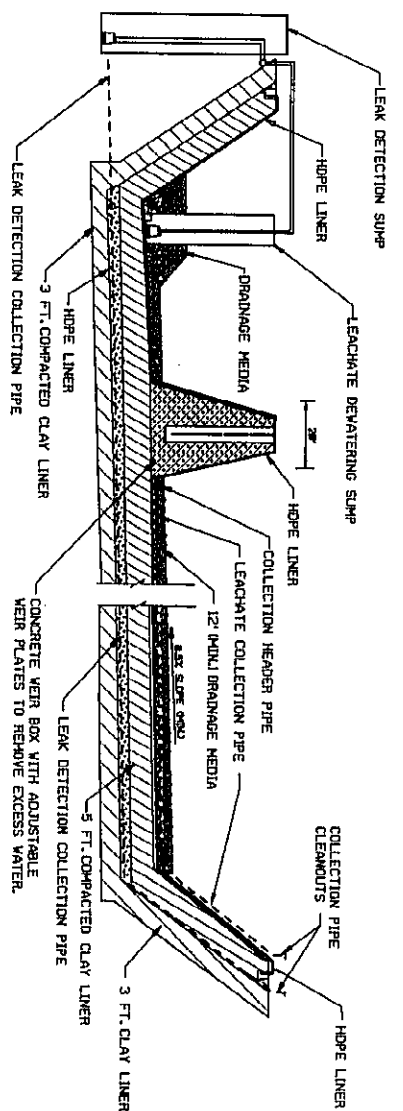
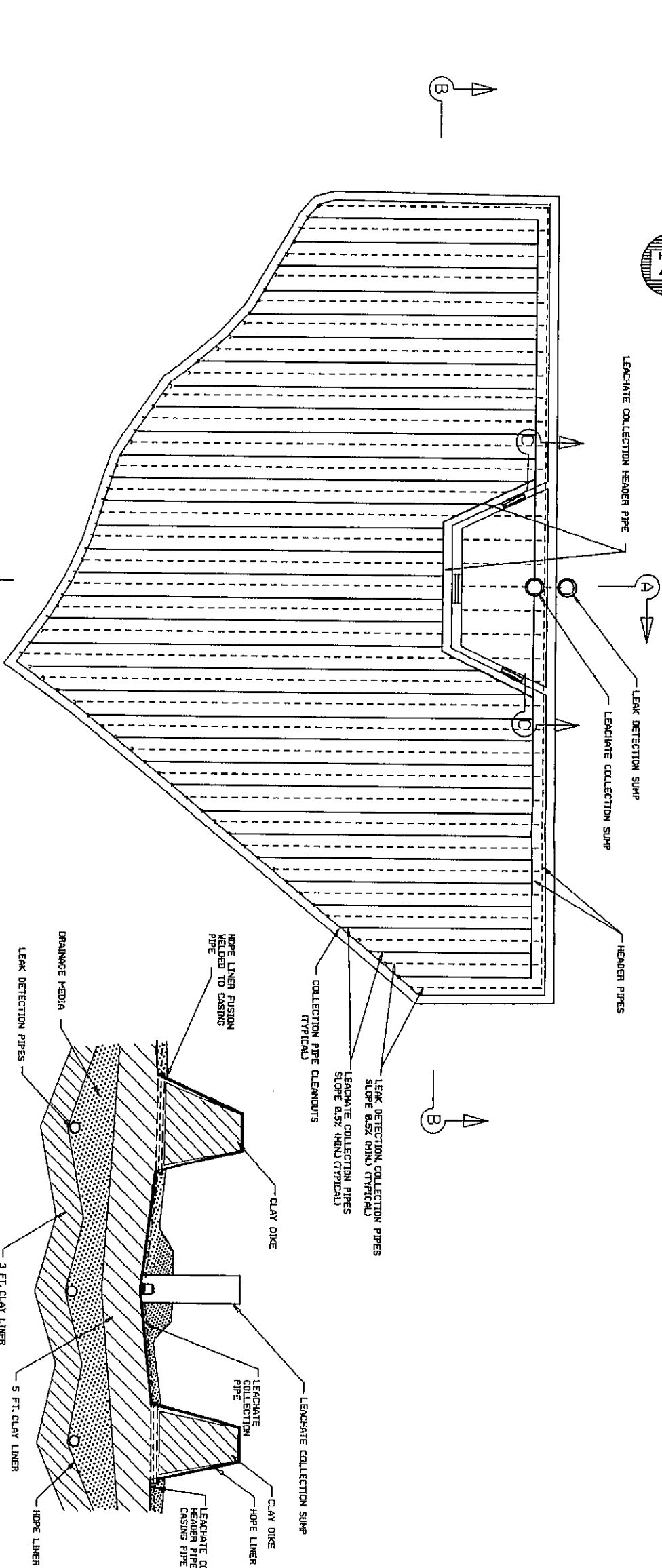

SECTION -A-
N.I.S.

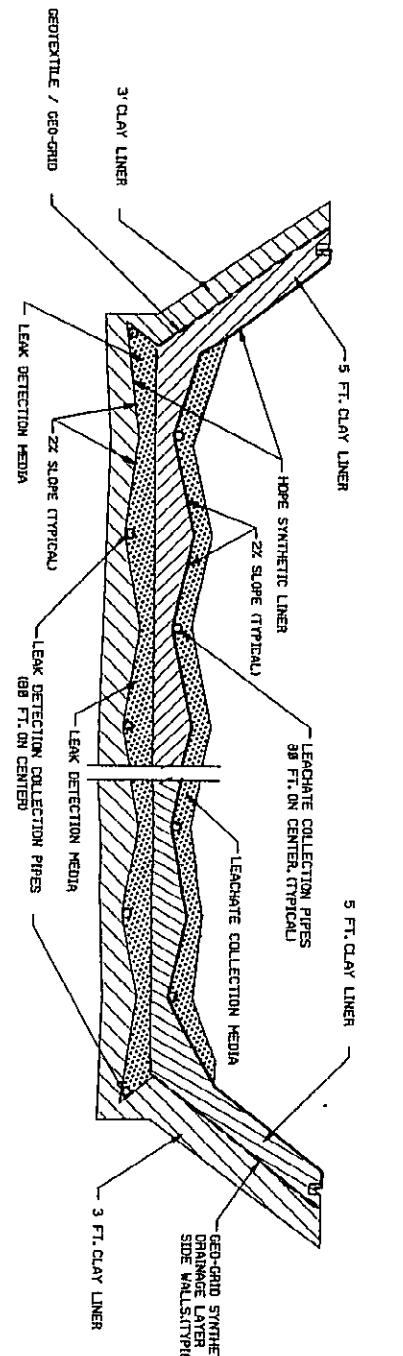

SECTION -B-
N.I.S.

SECTION -A-
N.I.S.

SECTION -B-
N.I.S.

CONCEPTUAL

NOTE: N.I.S. (NOT TO SCALE)

NO.	DATE	BY	CHKD BY	APP'D BY	REVISION
A	08/08/88	RHD	JB	JL	CHANGED DWG. NO. B2-507-927122 AND CONVERTED DRAWING TO MICRO-STATION
B	03/13/93	LEG	JJA	JJA	REMOVED TITILE BLOCK & ADDED HOPE LINER TO LEAK DETECTION SYSTEM

NO.	DATE	BY	CHKD BY	APP'D BY	REVISION
1	01/07/87	J.S. KOEHLER			ISSUED
2	01/07/87	J.S. KOEHLER			REVISED
3	02/73	J.S. KOEHLER			REVISED
4	02/73	J.S. KOEHLER			REVISED

NO.	DATE	BY	CHKD BY	APP'D BY	REVISION
1	01/07/87	J.S. KOEHLER			ISSUED
2	01/07/87	J.S. KOEHLER			REVISED
3	02/73	J.S. KOEHLER			REVISED
4	02/73	J.S. KOEHLER			REVISED

NO.	DATE	BY	CHKD BY	APP'D BY	REVISION
1	01/07/87	J.S. KOEHLER			ISSUED
2	01/07/87	J.S. KOEHLER			REVISED
3	02/73	J.S. KOEHLER			REVISED
4	02/73	J.S. KOEHLER			REVISED

NO.	DATE	BY	CHKD BY	APP'D BY	REVISION
1	01/07/87	J.S. KOEHLER			ISSUED
2	01/07/87	J.S. KOEHLER			REVISED
3	02/73	J.S. KOEHLER			REVISED
4	02/73	J.S. KOEHLER			REVISED

NO.	DATE	BY	CHKD BY	APP'D BY	REVISION
1	01/07/87	J.S. KOEHLER			ISSUED
2	01/07/87	J.S. KOEHLER			REVISED
3	02/73	J.S. KOEHLER			REVISED
4	02/73	J.S. KOEHLER			REVISED

CONCEPTUAL

NOTE: N.I.S. (NOT TO SCALE)

THE DOW CHEMICAL COMPANY
MIDLAND, MICHIGAN PONES

MICHIGAN DIVISION
TERTIARY POND
LEAK DETECTION AND
LEACHATE COLLECTION SYSTEM

PROJECT NUMBER: 927122
SCALE: AS NOTED
DATE: B2-507-927122
REVISED

NO. 2 UND