

MIOSHA Fact Sheet



Decking Used as a Work Platform During Bridgework

Bridgework has always been at the forefront of the heavy construction industry. Bridge contractors use many different designs for their permanent and temporary work platforms. There are times when these platforms are only used to catch debris to prevent its falling onto traffic or people below. At other times the platforms are designed as formwork for a concrete deck. Typically, plywood, plyform, or oriented strand board (OSB) is used. **Whatever the formwork or decking may be designed for, when a worker uses it to walk on or work from, it is a temporary work platform and must be designed to meet the requirements of MIOSHA, Construction Safety and Health Standard Part 12, Scaffolds and Scaffold Platforms.**

Construction Safety and Health Standard Part 12 – Scaffolds and Scaffold Platforms

Part 12, Rules 1218(1), (2), & (3) requirements for plywood scaffold platforms are stated below:

1. If plywood is used as a work platform, the plywood shall be supported by 2 by 10-inch planks. The planks shall support 2 parallel edges of the plywood and shall also be spaced not more than 24 inches center to center.
2. The plywood work surface shall be secured to the planks.
3. If the plywood work surface is a load-carrying member, it shall have a minimum thickness of 5/8 inch.

However, Rule 1210(1) allows for alternate platform designs. These alternate designs must be designed by a qualified person. The qualified person must consider Rule 1926.451(a)(1) that states, “Except as provided in paragraphs (a)(2), (a)(3), (a)(4), (a)(5) and (g) of this section, each scaffold and scaffold component shall be capable of supporting, without failure, its own weight and at least 4 times the maximum intended load applied or transmitted to it.”

Engineering Considerations for Plywood Work Platforms

There are many items to consider when designing a plywood work platform:

- Size and type of lumber grade for decking supports
- Size and type of plywood
- Span length of supports
- Spacing of supports
- Uplift due to wind and traffic
- Maximum intended load
- Anchorage of supports to the structure
 - Box beams
 - Precast I-beams
- Securing plywood to supports
 - Nailing pattern
 - Lapping pattern
 - Fasteners
- Inspections by the Competent Person
 - Inspect work platform daily and after any event that may compromise integrity or safety
 - Inspect for damaged or worn components (above and underneath)
 - Inspect for shifting plywood or supports

LEO is an equal opportunity employer/program.



Construction Safety and Health Division
530 West Allegan Street • P.O. Box 30645 • Lansing, MI 48909-8145
Overnight Mail Address: 525 West Allegan Street, Lansing, MI 48933
www.michigan.gov/miosha • 517-284-7680
CSH Fact Sheet - #007 • Revised 04/04/2022



Part 12 defines the competent person as one who is experienced and capable of identifying an existing or potential hazard in surroundings, or under working conditions, that is hazardous or dangerous to an employee and who has the authority and knowledge to take prompt corrective measures to eliminate the hazards.

Part 12 defines qualified person as one who, by possession of a recognized degree, certificate, or professional standing, or who by extensive knowledge, training, and experience, has successfully demonstrated his/her ability to solve or resolve problems related to the subject matter, the work, or the project.

Work Platform Tables for Bridge Construction Use

Listed below are work platform tables and their requirements that have been designed and reviewed by an independent engineer that will meet the criteria of Rule 1210(3). All of the following parameters apply:

Douglas Fir No 2 or better

Contractor may substitute Lumber that exceeds all the following strengths: F_B (Bending Strength) =2100psi, F_V (Shear strength parallel to grain) =270psi, $F_{c\perp}$ (Compression strength perpendicular to grain) =1300psi

| | | Maximum Support Clear Span in Inches | | | | | |
|---|-----------|--------------------------------------|------|--------|------|--------|------|
| Nominal lumber size used for support | 2x4 Flat | 31 | 36 | 40 | 44 | 47 | 50 |
| | 2x6 Flat | 37 | 42 | 47 | 52 | 56 | 60 |
| | 2x8 Flat | 40 | 47 | 52 | 57 | 62 | 66 |
| | 2x10 Flat | 45 | 52 | 58 | 63 | 68 | 73 |
| | 4x4 | 68 | 79 | 88 | - | - | - |
| Number of Supports per 8' sheet | | 4 | 5 | 6 | 7 | 8 | 9 |
| Spacing of Supports in inches | | 32 * | 24 + | 19.2 + | 16 + | 13.7 + | 12 + |

- * This support spacing requires the use of 3/4" Structural I Plyform for decking
- + This support spacing requires the use of 3/4" Structural I Plyform or 3/4"C-D Exposure Grade 1 for decking
- These span lengths require separate design

Spruce Pine Fir No 2 or better

Contractor may substitute Lumber that exceeds all the following strengths: F_B (Bending Strength) =2220psi, F_V (Shear strength parallel to grain) =200psi, $F_{c\perp}$ (Compression strength perpendicular to grain) =880psi

| | | Maximum Support Clear Span in Inches | | | | | |
|---|-----------|--------------------------------------|------|--------|------|--------|------|
| Nominal lumber size used for support | 2x4 Flat | 32 | 37 | 41 | 45 | 48 | 52 |
| | 2x6 Flat | 38 | 44 | 49 | 53 | 58 | 62 |
| | 2x8 Flat | 42 | 48 | 54 | 59 | 64 | 68 |
| | 2x10 Flat | 46 | 53 | 59 | 65 | 70 | 75 |
| | 4x4 | 70 | 81 | 91 | - | - | - |
| Number of Supports per 8' sheet | | 4 | 5 | 6 | 7 | 8 | 9 |
| Spacing of Supports in inches | | 32 * | 24 + | 19.2 + | 16 + | 13.7 + | 12 + |

- * This support spacing requires the use of 3/4" Structural I Plyform for decking
- + This support spacing requires the use of 3/4" Structural I Plyform or 3/4"C-D Exposure Grade 1 for decking
- These span lengths require separate design

- Maximum Clear Span in inches for supports spaced evenly along a standard sheet of plywood.

- 5 pounds per square foot (psf) dead loading and 20 psf live loading, per AASHTO Guide Design Specification for Bridge Temporary Works, 1995 Edition, Section 2.2.3.1.
- Designed as a personnel platform, for man loads only.
- Minimum factor of Safety = 4.0.
- Clear Span measured as distance between edge of flanges for steel beams, or distance between webs for concrete beams, plywood shall adequately cover the opening between beam flanges.
- Decking shall be 3/4" thickness.
- Contractor is responsible for assuring materials meet the specified lumber species and grades and are free from defects that affect strength.
- Contractor shall adequately brace decking to assure overall stability and resistance to uplift due to wind and traffic as determined by a competent person.
- Alternate proposed loadings, supports, wood species, grades or spans exceeding those listed in the chart would require a design approved by an engineer or Competent Person.
- The supports shall be cut to the maximum length that will allow for erection clearances with the beam layout. A minimum bearing length of 1½ inches along the support is required on the beam flange.
- Ends of plywood sheets shall be supported by half the width of a support member.
- Deviation from these span tables would require a design approved by a Professional Engineer.

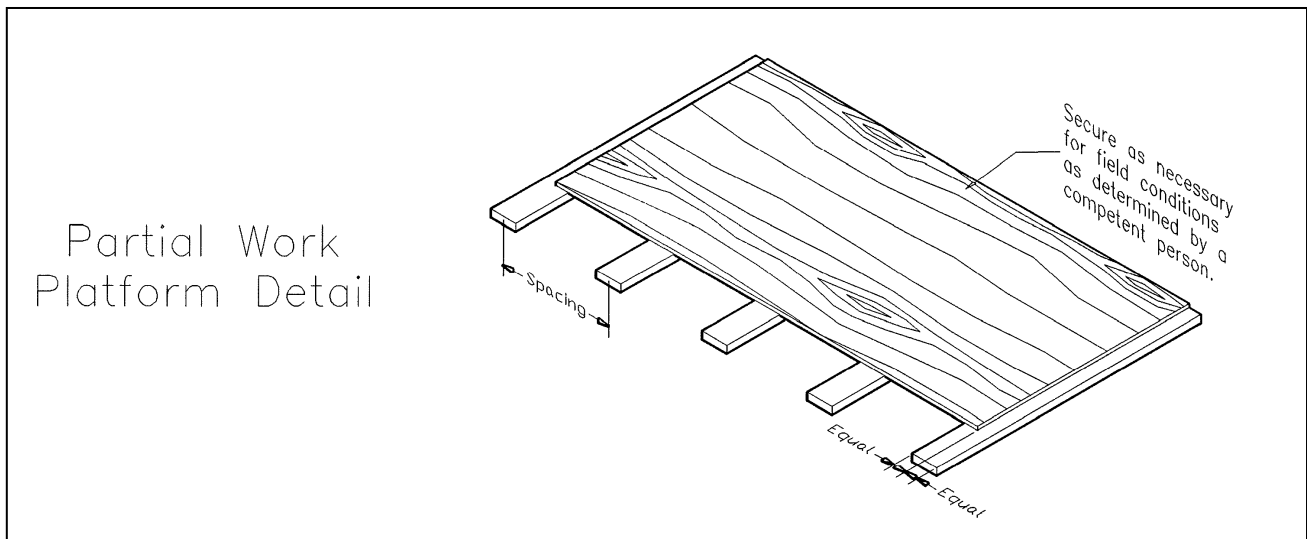

The key to preventing injuries and fatalities related to plywood work platforms is good employee training and frequent/thorough inspections. The hazards associated with scaffold platforms must be addressed in an Accident Prevention Program required by Construction Safety and Health Standard, [Part 1, General Rules](#), Rule 114(1).

This Construction Fact Sheet is provided for guidance to the bridge building industry as an alternate design and installation procedure for temporary plywood work platforms.

For additional assistance, please contact the Construction Safety and Health Division at 517-284-7680 or the Consultation Education and Training Division at 517-284-7720. Construction Safety and Health Standards can be viewed on the MIOSHA website at www.michigan.gov/mioshastandards.