



DEPARTMENT OF LABOR AND ECONOMIC OPPORTUNITY
CONSTRUCTION STANDARD

Filed with the Secretary of State on August 17, 1979 (as amended November 23, 1982)
(as amended January 11, 1988) (as amended July 8, 1993)
(as amended September 3, 1996) (as amended March 14, 2013) **(as effective January 3, 2024)**

These rules take effect immediately upon filing with the secretary of state unless adopted under section 33, 44, or 45a(9) of the administrative procedures act of 1969, 1969 PA 306, MCL 24.233, 24.244, or 24.245a.

Rules adopted under these sections become effective 7 days after filing with the Secretary of State.

(By authority conferred on the director of the Michigan department of labor and economic opportunity by sections 19 and 21 of the Michigan occupational safety and health act, 1974 PA 154, MCL 408.1019 and 408.1021, and Executive Reorganization Order Nos. 1996-2, 2003-1, 2008-4, 2011-4, and 2019-3, MCL 445.2001, 445.2011, 445.2025, 445.2030, and 125.1998)

R 408.40901, R 408.40925, R 408.40926, R 408.40927, R 408.40932, R 408.40933, R 408.40941, R 408.40942, R 408.40943, R 408.40945, R 408.40951, and R 408.40953 of the Michigan Administrative Code are amended, as follows:

PART 9, EXCAVATION, TRENCHING, AND SHORING

Table of Contents:

R 408.40901. Scope and referenced standards.....	1	R 408.40941. Excavation; angle of repose.	4
R 408.40925. Definitions A to Q.	1	R 408.40942. Supporting systems; angle of repose; tie backs; tight sheeting; additional bracing.	5
R 408.40926. Definitions; S.	2	R 408.40943. Additional requirements for trench support systems	6
R 408.40927. Definitions; T, U.....	3	R 408.40944. Benching and sloping.	7
R 408.40931. Locating utility lines.	3	R 408.40945. Trenching boxes and shields.....	7
R 408.40932. Excavation; consideration of soil types; water; slide hazards.	4	R 408.40951. Walkways, sidewalks, roadways.	7
R 408.40933. Excavation; obstructions; retaining materials; egress; guarding; heavy equipment.....	4	R 408.40953. Adjacent structures; protection; design; inspection of shoring, bracing, and underpinning.....	7
R 408.40934. Hazardous atmospheres; testing and controls.	4	Appendix.....	8

R 408.40901. Scope and referenced standards.

Rule 901. (1) This part pertains to the digging of excavations and trenches which an employee is required to enter and the supporting systems used on construction operations.

(2) The following Michigan occupational safety and health (MIOSHA) standards are referenced in these rules:

(a) Construction Safety and Health Standard Part 21. "Guarding of Walking and Working Areas," R 408.42101 to R 408.42160.

(b) Construction Safety Standard Part 45. "Fall Protection," R 408.44501 to R 408.44502.

(3) Up to 5 copies of the standards listed in subrule (2) of this rule may be obtained at no charge from the Department of Labor and Economic Opportunity, MIOSHA, Standards and FOIA Section, 530 West Allegan Street, P.O. Box 30645, Lansing, Michigan,

48909-8145 or via the internet at the following website: www.michigan.gov/mioshastandards. For quantities greater than 5, the cost, as of the time of adoption of these rules, is 4 cents per page.

R 408.40925. Definitions A to Q.

Rule 925. (1) "Angle of repose" means the maximum permissible slope as determined by table 1.

(2) "Benching" means a method of protecting employees from cave-ins by excavating the sides of an excavation to form 1 or a series of horizontal levels or steps, usually with vertical or near-vertical surfaces between levels.

(3) "Braces" or "struts" means the horizontal cross members of a shoring system that bear against the uprights or stringers.

(4) "Cave-in" means the separation of a mass of soil or rock material from the side of an excavation, or the

loss of soil from under a trench shield or support system, and its sudden movement into the excavation, either by falling or sliding, in sufficient quantity so that it could entrap, bury, or otherwise injure and immobilize a person.

(5) "Competent person" means an individual who is capable of identifying existing and predictable hazards in the surroundings or working conditions which are unsanitary, hazardous, or dangerous to employees, and who has authorization to take prompt corrective measures to eliminate them.

(6) "Excavation" means any man-made cut, cavity, trench, or depression in the earth's surface, including its sides, walls, or faces, formed by earth removal.

(7) "Hazardous atmosphere" means an atmosphere which, by reason of being any of the following, may cause death, illness, or injury:

- (a) Explosive.
- (b) Flammable.
- (c) Poisonous.
- (d) Corrosive.
- (e) Oxidizing.
- (f) Irritating.
- (g) Oxygen deficient.
- (h) Toxic.
- (i) Otherwise harmful.

(8) "Kickout" means the accidental release or failure of a stringer or brace.

(9) "Protective system" means a method of protecting employees from cave-ins, from material that could fall or roll from an excavation face or into an excavation, or from the collapse of adjacent structures. Protective systems include support systems, sloping and benching systems, shield systems, and other systems that provide the necessary protection.

(10) "Qualified person" means an individual who, by possession of a recognized degree or certificate of professional standing, or who, by extensive knowledge, training, and experience, has successfully demonstrated the ability to solve or resolve problems relating to the subject matter and work.

(11) "Ramp" means an inclined walking or working surface that is used to gain access to 1 point from another and is constructed from earth or from structural materials such as steel or wood.

(12) "Registered professional engineer" means a person who is registered as a professional engineer in the state where the work is to be performed. However, a professional engineer, registered in any state is deemed to be a registered professional engineer within the meaning of this standard when approving designs for manufactured protective systems or tabulated data to be used in interstate commerce.

R 408.40926. Definitions; S.

Rule 926. (1) "Sheeting" means the members of a shoring system that retain the earth in position and in turn are supported by other members of the shoring system.

(2) "Sheet piling" means a continuous row of timber or steel piles driven in close contact to provide a tight wall to resist lateral pressure of water, adjacent earth, or other materials.

(3) "Shield" or "shield system" means a structure that is able to withstand the forces imposed on it by a cave-in and thereby protect employees within the structure. Shields can be permanent structures or can be designed to be portable and moved along as work progresses. Additionally, shields can be either premanufactured or job-built in accordance with R 408.40932, R 408.40942, R 408.40943, R 408.40945, and R 408.40953. Shields used in trenches are usually referred to as trench boxes or trench shields.

(4) "Shoring" or "shoring system" means a structure such as a metal hydraulic, mechanical, or timber shoring system that supports the sides of an excavation and which is designed to prevent cave-ins.

(5) "Sides" sometimes called faces or walls, mean the vertical or inclined earth surfaces formed as a result of excavation work.

(6) "Slope" means the acute angle formed by the side of a trench or excavation and the horizontal plane.

(7) "Soil" means any of the following:

(a) "Clay" means a very fine textured soil that derives its resistance to displacement from cohesion and may be:

(i) "Soft clay" means a clay-type soil that has an unconfined strength of less than 1.0 ton per square foot.

(ii) "Medium clay" or "plastic" means a clay-type soil that has a minimum unconfined strength of 1.0 ton per square foot.

(iii) "Firm soil" means a clay-type soil that is resistant to forces causing rupture or displacement. A firm clay has a minimum unconfined strength of 1.5 tons per square foot.

(iv) "Stiff clay" means a clay-type soil that is very resistant to forces causing rupture or displacement. A stiff clay has a minimum unconfined strength of 2.5 tons per square foot.

(b) "Fill" means a manmade soil condition that may be constructed of any type of soil or combination thereof.

(c) "Granular soil" means a coarse grained soil that does not possess cohesion but derives its strength from internal friction.

(d) "Organic soil" means a soil that contains significant amounts of peat, muck, or marl.

(e) "Running soil" means any type of soil that has insufficient strength to stand unsupported. Running soil tends to run or slough into the excavation as the excavation is being dug.

(8) "Stringers" mean the horizontal members of a trench shoring system whose sides bear against the uprights or earth.

(9) "Structural ramp" means a ramp built of steel or wood, usually used for vehicle access. Ramps made of soil or rock are not considered structural ramps.

(10) "Support system" means a structure such as underpinning, bracing, or shoring, which provides support to an adjacent structure, underground installation, or the sides of an excavation.

R 408.40927. Definitions; T, U.

Rule 927. (1) "Tabulated data" means tables and charts approved by a registered professional engineer and used to design and construct a protective system.

(2) "Toe of slope" means the point at which the side of an excavation intersects the lowest level of the excavation.

(3) "Trench" means an excavation having a depth greater than its width measured at the bottom.

(4) "Trench jack" means a screw or hydraulic jack used as a brace in a trench shoring system.

(5) "Trench shield," sometimes called a trench box, means a trench shoring system composed of steel plates and bracing, welded or bolted together, which can be moved along as work progresses.

(6) "Uprights" mean the vertical members of a trench shoring system.

R 408.40931. Locating utility lines.

Rule 931. (1) An employer shall not excavate in a street, highway, public place, a private easement of a public utility, or near the location of a public utility facility owned, maintained, or installed on a customer's premises, without having first ascertained the location of all underground facilities of a public utility in the proposed area of excavation.

(2) Upon receiving the information from the public utility, an employer shall exercise reasonable care when working in close proximity to the underground facilities of any public utility. If the facilities are to be exposed, or are likely to be exposed, only hand digging shall be employed in such circumstances and such support, as may be reasonably necessary for protection of the facilities, shall be provided in and near the construction area.

(3) When any contact with, or damage to, any pipe, cable, or its protective coating, or any other underground facility of a public utility occurs, the public utility shall be notified immediately by the employer responsible for operations causing the damage. If an energized electrical cable is severed, an energized conductor is exposed, or dangerous fluids or gasses are escaping from a broken line, the employer shall evacuate the employees from the immediate area while awaiting the arrival of the public utility personnel.

R 408.40932. Excavation; consideration of soil types; water; slide hazards.

Rule 932. (1) If different textured soils are encountered in the side of an excavation, each soil type of the excavation shall be cut to the proper angle of repose, except that the slope shall not steepen between the toe of the slope and the ground level where soft clay or running soil is encountered in the lower cut.

(2) An employee shall not work in an excavation in which there is accumulated water or in which water is accumulating unless precautions have been taken to protect employees against the hazards posed by water accumulation. The precautions necessary to protect employees adequately vary with each situation, but may include special support or shield systems to protect from cave-ins, water removal to control the level of accumulating water, or the use of a safety harness and lifeline.

(3) If water is controlled or prevented from accumulating by the use of water removal equipment, the water removal equipment and operation shall be monitored by a competent person or a monitoring system to ensure that the equipment is properly operated.

(4) An ongoing inspection of an excavation or trench shall be made by a competent person. After every rainstorm or other hazard-producing occurrence, an inspection shall be made by a competent person for evidence of possible slides or cave-ins. Where these conditions are found, all work shall cease until additional precautions, such as additional shoring or reducing the slope, have been accomplished.

(5) When installed forms, walls, or similar structures create a trench between the form, wall, or structure and the side of the excavation, an employer shall comply with the provisions of R 408.40941 to R 408.40944.

R 408.40933. Excavation; obstructions; retaining materials; egress; guarding; heavy equipment.

Rule 933. (1) A tree, boulder, rock fragments, or other obstructions whose movement could cause injury to an employee shall be removed or supported.

(2) An excavation that an employee is required to enter shall have excavated and other material stored and retained not less than 2 feet from the excavation edge.

(3) When mobile equipment is utilized or permitted adjacent to an excavation where the operator's vision is restricted, stop logs or barricades shall be utilized or a signal person shall be used.

(4) An excavation 48 or more inches in depth and occupied by an employee shall be provided with either a ladder extending not less than 3 feet above the top as a means of access or with a ramp meeting the requirements of subrule (5) of this rule. Lateral travel along the wall of a trench to a ladder or other means of egress shall not exceed 25 feet.

(5) An earth ramp may be used in place of a ladder if it meets all of the following requirements:

(a) The ramp material shall be stable.

(b) The sides of the excavation above the ramp shall be maintained to the angle of repose or sheeted or shored along the means of egress.

(c) The degree of angle of the ramp shall not be more than 45 degrees.

(d) Vertical height between the floor of the trench and the toe of the ramp shall not exceed 30 inches.

(6) Structural ramps that are used solely by employees as a means of access or egress from excavations shall be designed by a competent person. Structural ramps used for access or egress of equipment shall be designed by a competent person qualified in structural design and shall be constructed in accordance with the design.

(7) Ramps and runways constructed of 2 or more structural members shall have the structural members connected together to prevent displacement.

(8) Structural members used for ramps and runways shall be of uniform thickness.

(9) Cleats or other appropriate means used to connect runway structural members shall be attached to the bottom of the runway or shall be attached in a manner to prevent tripping.

(10) Structural ramps used in lieu of steps shall be provided with cleats or other surface treatments on the top surface to prevent slipping.

R 408.40934. Hazardous atmospheres; testing and controls.

Rule 934. To prevent exposure to harmful levels of atmospheric contaminants and to assure acceptable atmospheric conditions, all of the following requirements shall apply:

(a) Where an oxygen deficiency (an atmosphere that contains less than 19.5% oxygen) or a hazardous atmosphere exists, such as in excavations in areas where hazardous substances are stored nearby, the atmosphere in the excavation shall be tested before employees enter excavations that are more than 4 feet (1.22 m) deep.

(b) Precautions shall be taken to prevent employee exposure to atmospheres that contain less than 19.5% oxygen and any other hazardous atmosphere. These precautions include providing proper respiratory protection or ventilation in accordance with the requirements of this part.

(c) Precautions shall be taken, such as providing ventilation, to prevent employee exposure to an atmosphere that contains a concentration of a flammable gas in excess of 20% of the lower flammable limit of the gas.

(d) When controls are used that are intended to reduce the level of atmospheric contaminants to acceptable levels, testing shall be conducted as often as necessary to ensure that the atmosphere remains safe.

R 408.40941. Excavation; angle of repose.

Rule 941. (1) The side of an excavation more than 5 feet deep shall be sloped as prescribed in table 1, unless supported as prescribed in this part.
 (2) An excavation less than 5 feet in depth shall also be effectively protected when examination of

the ground indicates hazardous earth movement may be expected.

TABLE 1

MAXIMUM ALLOWABLE ANGLE OF REPOSE FOR THE SIDE OF AN EXCAVATION IN EXCESS OF 5' DEPTH

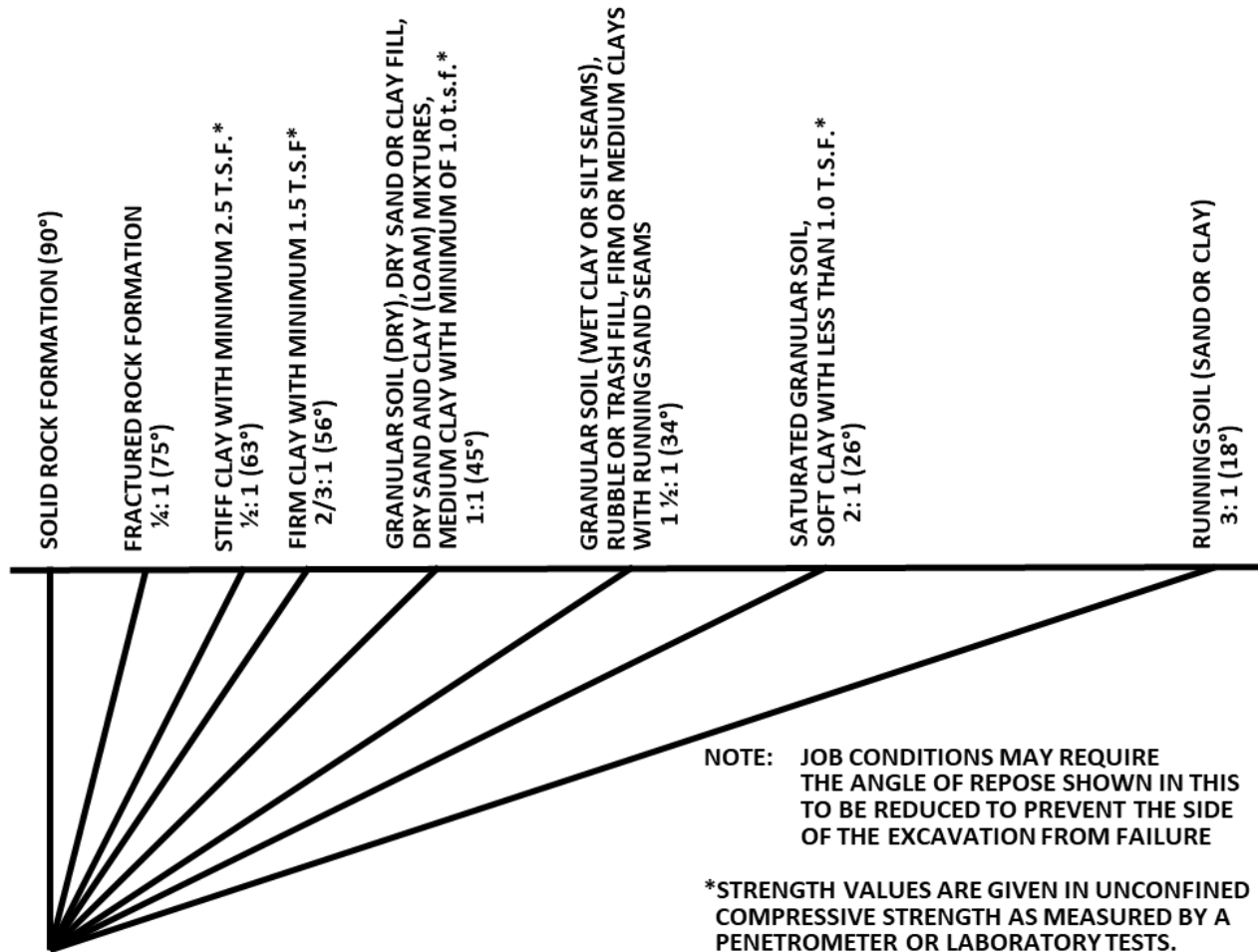

NOTE: JOB CONDITIONS MAY REQUIRE THE ANGLE OF REPOSE SHOWN IN THIS TO BE REDUCED TO PREVENT THE SIDE OF THE EXCAVATION FROM FAILURE

*STRENGTH VALUES ARE GIVEN IN UNCONFINED COMPRESSIVE STRENGTH AS MEASURED BY A PENETROMETER OR LABORATORY TESTS.

R 408.40942. Supporting systems; angle of repose; tie backs; tight sheeting; additional bracing.

Rule 942. (1) The angle of repose and the design of the supporting system for a side of an excavation shall be based on the evaluation of all of the following factors:

- (a) Depth of cut and type of soil.
- (b) Possible variation in the water content of the material while the excavation is open.
- (c) Anticipated changes in the material due to exposure to air, sun, water, or freezing temperatures.
- (d) Load imposed by structures, equipment, overlying material, or stored material.
- (e) Vibration from traffic, equipment, or blasting.

(2) A support system shall be designed by a qualified person. The design of the support system shall be maintained at the jobsite. Changes from

the design of the support system shall be approved by a qualified person.

(3) Tie rods and other forms of tie backs used to restrain the top of sheeting shall be anchored a minimum of 10 feet. The measurement to the anchor point shall start at the intersection of an angle of repose with the surface of the soil retained. The tie back and anchor shall be capable of restraining any pressure exerted on the system.

(4) When sheeting or sheet piling is used, pressures due to existing ground water conditions shall be considered in the design. Sheet piling shall be driven to the predetermined depth set forth in the required design. Changes from the design shall be approved by the designer of the support system.

(5) Materials used for a supporting system shall be in good serviceable condition. When timbers are used, they shall be sound and free of large or loose knots.

(6) A supporting system shall include additional bracing approved by the designer of the support system when the sides of excavations are cut adjacent to a previous known excavation or a known fill, particularly when the separation between the previous excavation and the new excavation is less than the depth of the excavation.

(7) Sheeting shall be braced or anchored at the bottom and along the vertical plane to prevent lateral movement.

(8) Protective systems for use in excavations more than 20 feet in depth must be designed by a registered professional engineer.

R 408.40943. Additional requirements for trench support systems

Rule 943. (1) Members of support systems shall be securely connected together to prevent sliding, falling, kickouts, or other predictable failure.

(2) The backfilling and the removal of a support system for a trench shall progress together from the bottom of the trench. In unstable or running soil, the jacks and braces shall be removed from above the trench after employees have cleared the trench.

(3) The excavation of material to a level that is not more than 2 feet, .61 m, below the bottom of the members of a support system shall be permitted, but only if the system is designed to resist the forces calculated for the full depth of the trench and if there are no indications, while the trench is open, of a possible loss of soil from behind or below the bottom of the support system.

(4) The installation of a support system shall be closely coordinated with the excavation of trenches.

(5) Support systems shall be installed and removed in a manner that protects employees from cave-ins, structural collapses, or from being struck by members of the support system.

(6) Individual members of support systems shall not be subjected to loads exceeding those which those members were designed to withstand.

(7) Before temporary removal of individual members begins, additional precautions shall be taken to ensure the safety of employees, such as installing other structural members to carry the loads imposed on the support system.

R 408.40944. Benching and sloping.

Rule 944. (1) The angle of repose shall be flattened when an excavation has water conditions, silty materials, loose boulders, or areas where erosion, deep frost action, or slide planes appear.

(2) When benching the side of an excavation, the vertical rise shall not be more than 5 feet and the step back shall extend at least to the angle of repose as required by table 1.

(3) When benching a side of a trench, the height of the lower bench shall not be more than the lesser of 5 feet or width of the trench measured at the bottom.

(4) An employee shall not be permitted to work on sloped or benched excavations at levels above another employee, except when an employee at the lower level is protected from the hazard of falling, rolling, or sliding material or equipment.

R 408.40945. Trenching boxes and shields.

Rule 945. (1) Portable trench boxes or sliding trench shields may be used for the protection of personnel in place of a shoring system or sloping. Where such trench boxes or shields are used, they shall be designed, constructed, and maintained in a manner that provides protection equal to or greater than the sheeting or shoring required for the trench.

(2) The use of benching in conjunction with a portable trench box is permitted when the toe of the trench box is not more than 2 feet above the trench bottom, but only if the trench box is designed to resist the forces calculated for the full depth of the trench and if there are no indications, while the trench is open, of a possible cave-in below the bottom of the trench box.

(3) An employee shall not be allowed in shields when shields are being installed, removed, or moved vertically.

(4) Shield systems shall not be subjected to loads exceeding those which the system was designed to withstand.

(5) Shields shall be installed in a manner to restrict lateral or other hazardous movement of the shield in the event of the application of sudden lateral loads.

(6) Employees shall be protected from the hazard of cave-ins when entering or exiting the areas protected by shields.

R 408.40946. Rescinded.

R 408.40951. Walkways, sidewalks, roadways.

Rule 951. (1) Sidewalks, pavements, and appurtenant structure shall not be undermined unless a support system or another method of protection is provided to

protect employees from the possible collapse of such structures.

(2) If an employee or equipment is required or permitted to cross a trench or ditch, a walkway, runway, ramp, or bridge shall be provided and shall have a designed capacity of not less than 3 times the imposed load. A guardrail prescribed by the provisions of Construction Safety and Health Standard Part 21. Guarding of Walking and Working Areas, R 408.421 to R 408.42160 and Construction Safety Standard Part 45. Fall Protection, R 408.42101 and R 408.44501, shall be provided.

R 408.40952. Rescinded.

R 408.40953. Adjacent structures; protection; design; inspection of shoring, bracing, and underpinning.

Rule 953. (1) A structure that is adjacent to an excavation or trench below the level of the base or footing of any foundation or retaining wall shall be protected against settlement, lateral movement, undermining, or washout.

(2) Before the excavation begins, the design of the protection used shall be set forth by a qualified person who is knowledgeable in the subject area.

(3) The shoring, bracing, and underpinning shall be inspected daily or more often, as conditions warrant, by a competent person.

(4) Where the stability of adjoining buildings, walls, or other structures is endangered by excavation operations, support systems such as shoring, bracing, or underpinning shall be provided to ensure the stability of such structures for the protection of employees.

(5) Excavation below the level of the base or footing of any foundation or retaining wall that could be reasonably expected to pose a hazard to employees shall not be permitted except when 1 of the following applies:

(a) A support system, such as underpinning, is provided to ensure the safety of employees and the stability of the structure.

(b) The excavation is in stable rock.

(c) A registered professional engineer has approved the determination that the structure is sufficiently removed from the excavation so as to be unaffected by the excavation activity.

(d) A registered professional engineer has approved the determination that such excavation work will not pose a hazard to employees.

APPENDIX

The following pages are not a part of the mandatory requirements of this safety standard. They are, however, examples of good engineering practices based on the rules contained herein.

EXAMPLES OF EXCAVATION & TRENCH PROTECTION

EXAMPLE 1 0-5' Deep

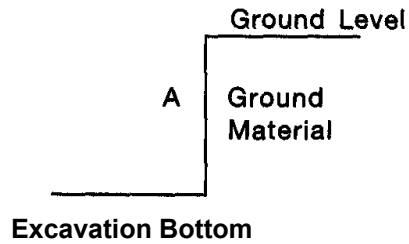

SIDE A: If examination of the ground indicated hazardous ground movement, Side A shall be cut to the angle of repose or a supporting system shall be provided.

EXAMPLE 2 More than 5' Deep

A. *Stiff Clay*

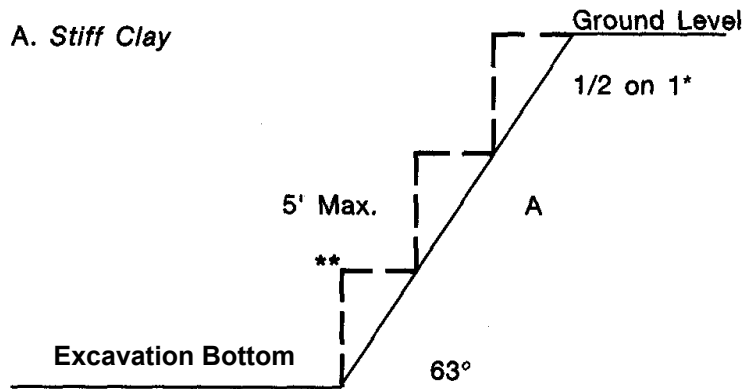

* 1/2 HORIZONTAL: 1 VERTICAL

** See rule 944(3) for lower bench height.

EXAMPLE 2 More than 5' Deep (continued)

B. Firm Clay

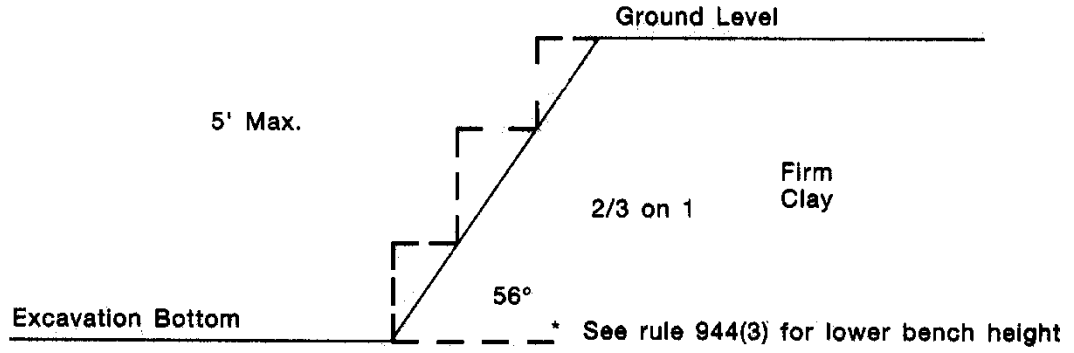

C. Granular Material

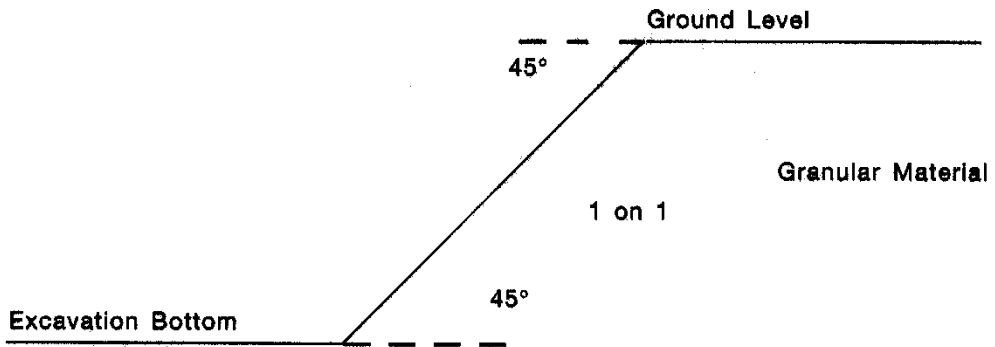

D. Granular Material (Wet Clay or Silt Seams)

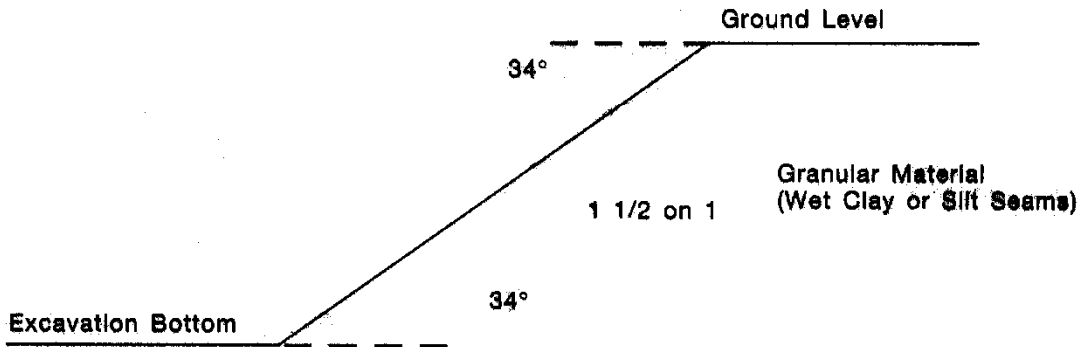

E. Saturated Granular Material or Soft Clay

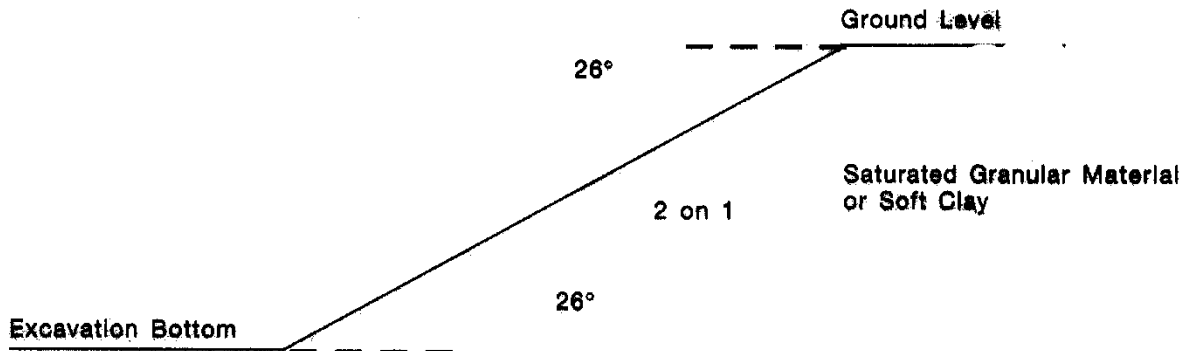

EXAMPLE 3 Support System — Sheet Piling

Wet Granular Material

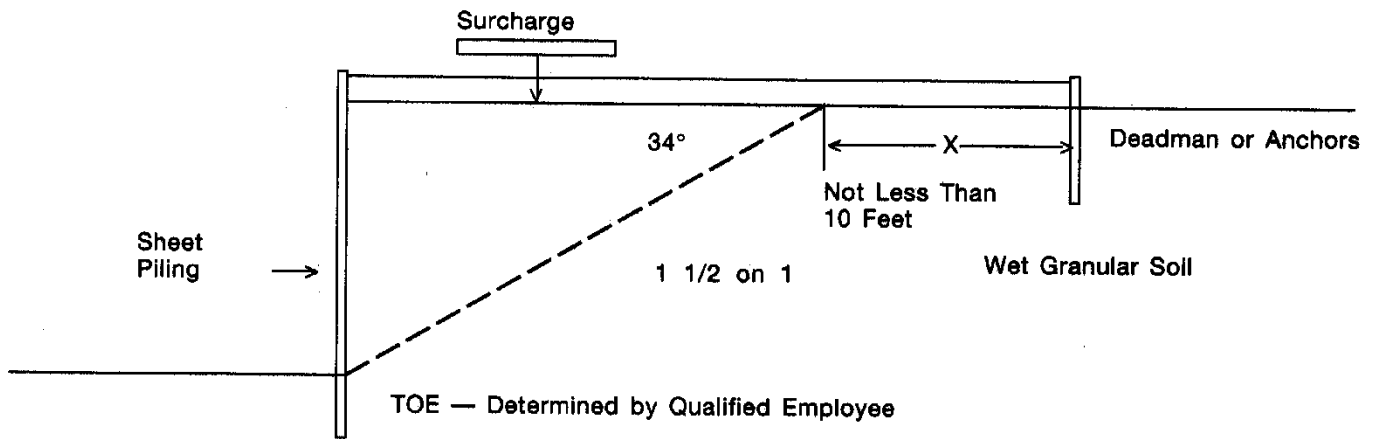

The design of the supporting system should take into consideration any surcharge, such as, stockpiled material, equipment, or hydrostatic pressure that must be supported by the system.

X = Not Less than 10'

EXAMPLE 4 Wall in Place

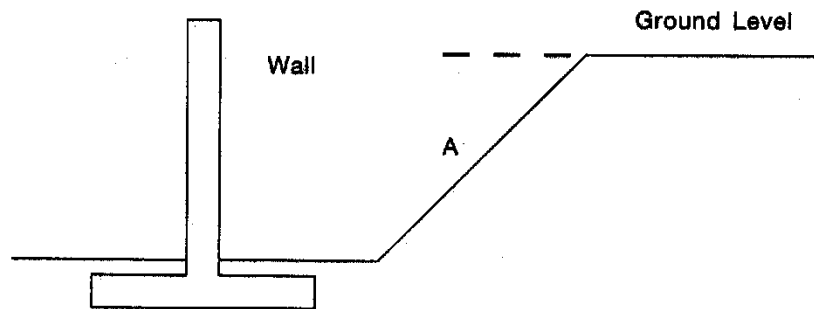

Side A: Side A should be cut to the angle of repose or a supporting system provided.

If a support system is designed for Side A, no braces or members should bear against the wall unless the wall is designed to withstand bracing loads.

EXAMPLE 5 Different Textured Soils

Case 1

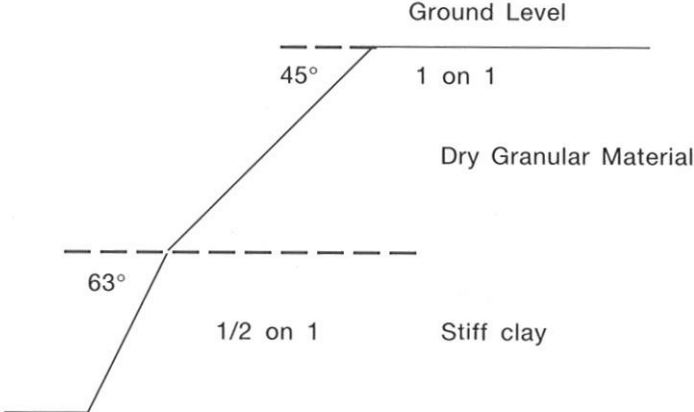

Case 2

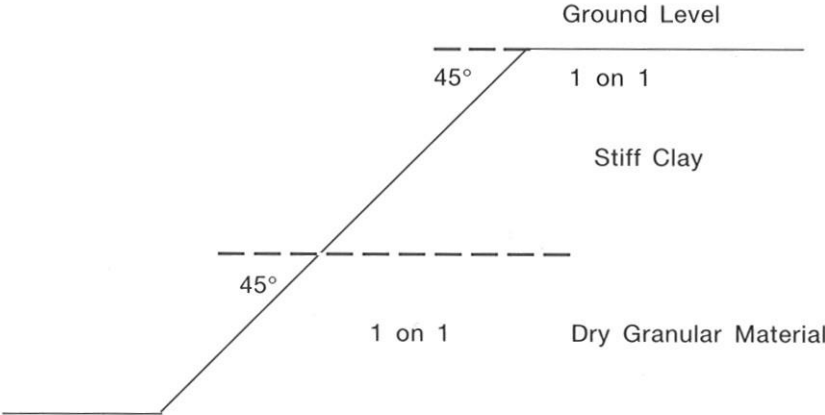

EXAMPLE 6 0-5' Deep

TRENCHES

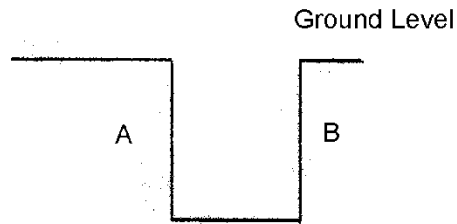

SIDES A & B: If examination of the ground indicates ground movement may be expected Sides A & B shall be cut to the angle of repose or a supporting system shall be provided.

EXAMPLE 7 Trench Shoring System

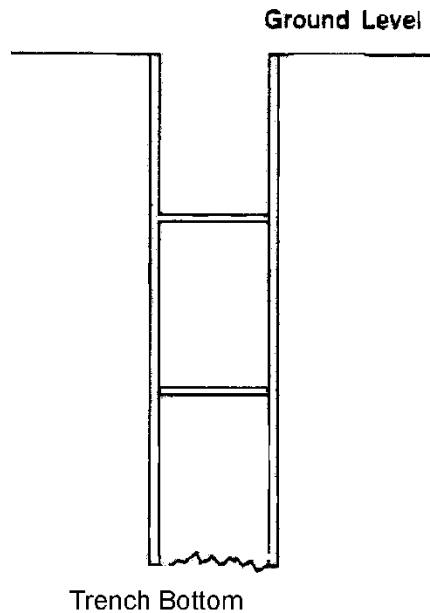

A trench support system shall be designed by a qualified employee knowledgeable in the field. The arrangement of stringers, struts, and braces should be a shoring system designed by a qualified person and installed as designated by the plans.

**EXAMPLE 8 Use of a Trench Supporting System
Such as a trench shield not extending to ground level**

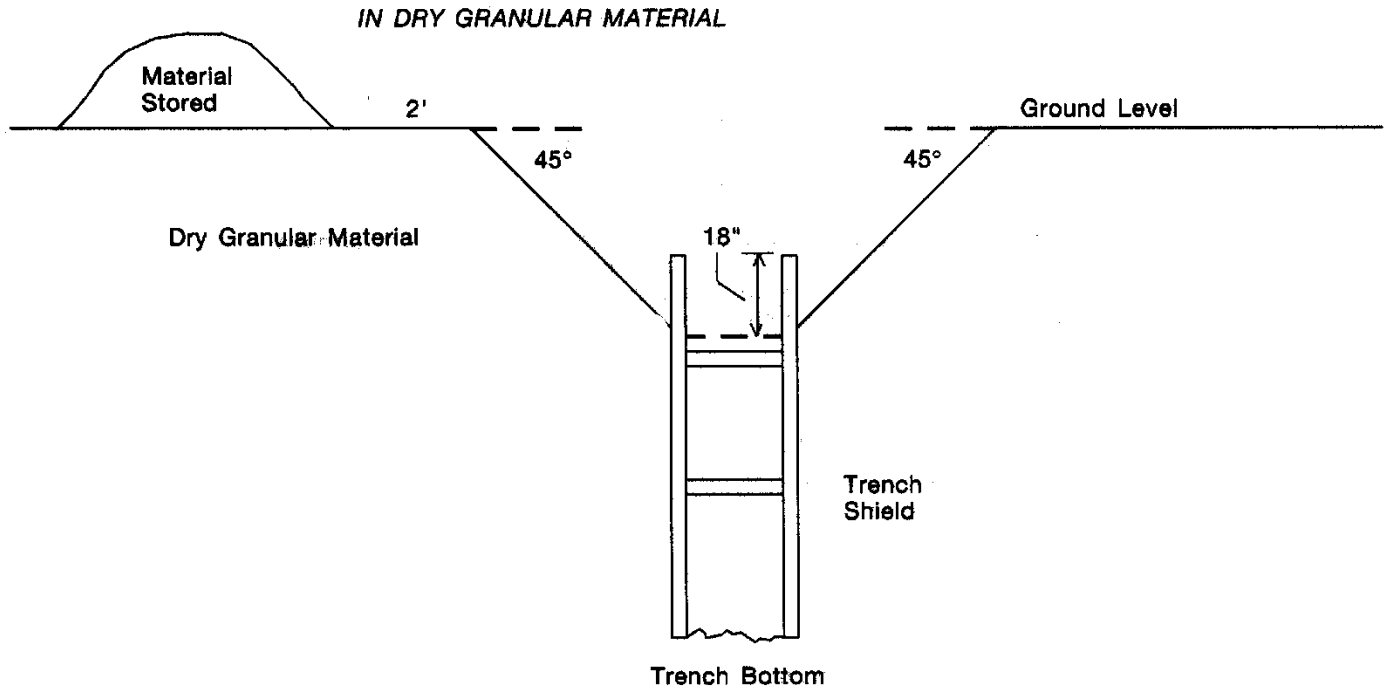

EXAMPLE 9 Trench Cut in Sloping Ground

MEDIUM CLAY

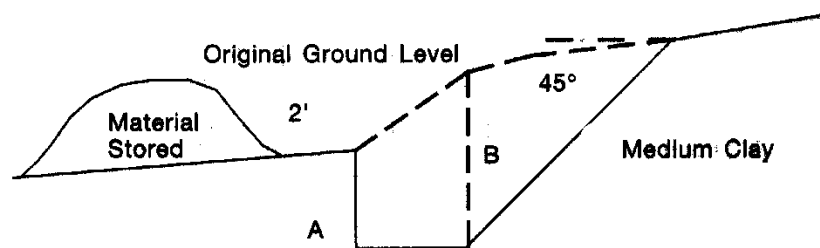

- If Side A is 5' or less and Side B is more than 5'
- (1) Side A should be sloped as provided for in Example 6.
 - (2) Side B should be cut to the correct angle of repose
 - (3) All excavated material should be stored on the low side of the trench, if possible.

EXAMPLE 10 Trench Cut in Different Textured Materials

Case 1

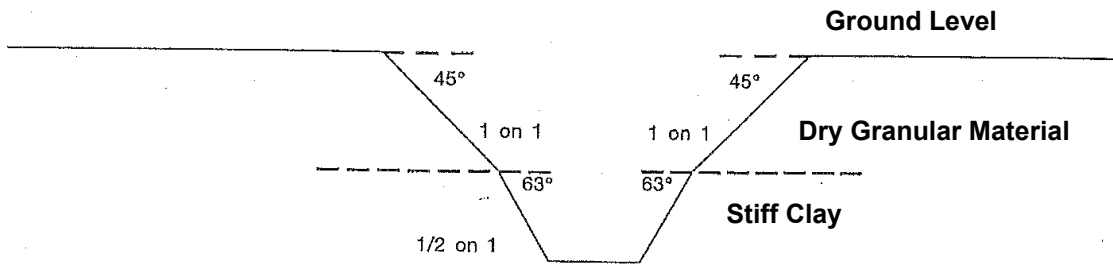

Case 2

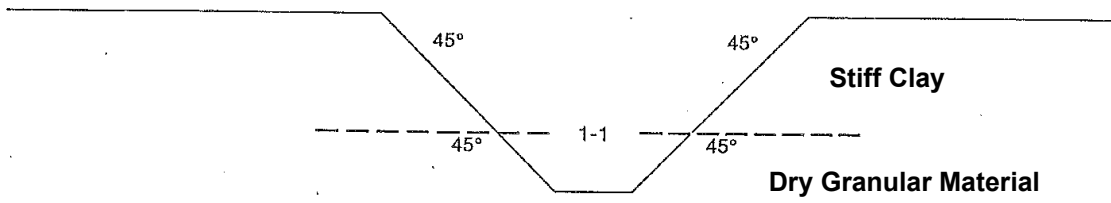

EXAMPLE 11 Fill Areas

Case 1 Dry Clay or Sand Fill

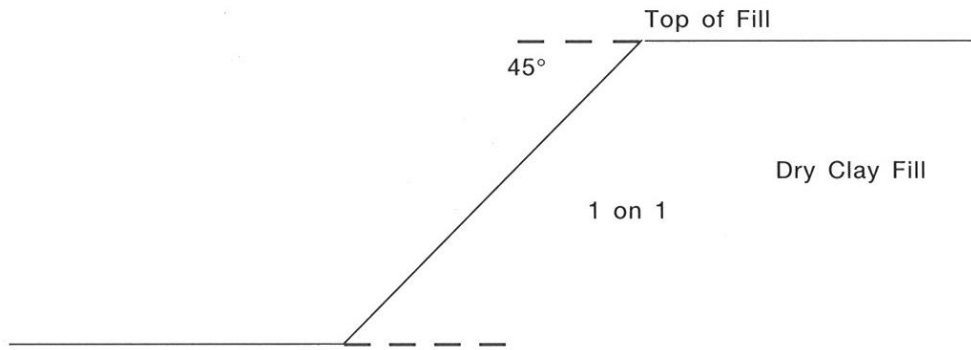

Case 2 Wet Soil, Rubble, Trash or Organic Material Fill

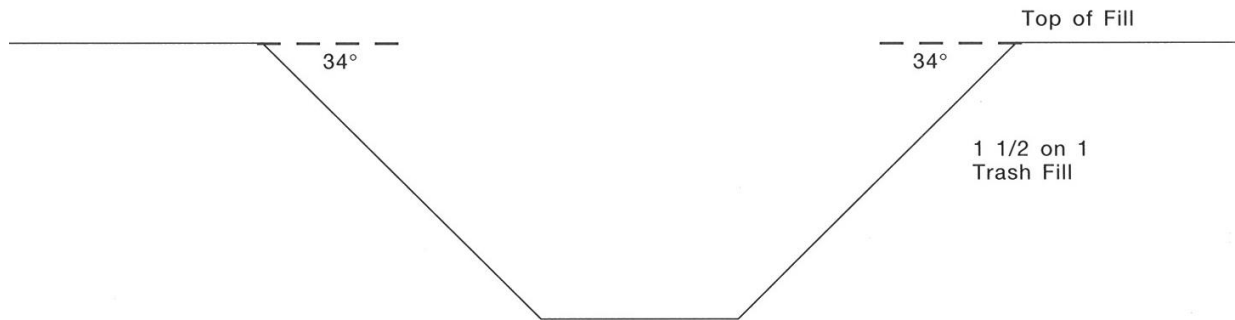

EXAMPLE 12

Excavation — Saturated sand, soft clay or organic soil encountered at depth under fill area.

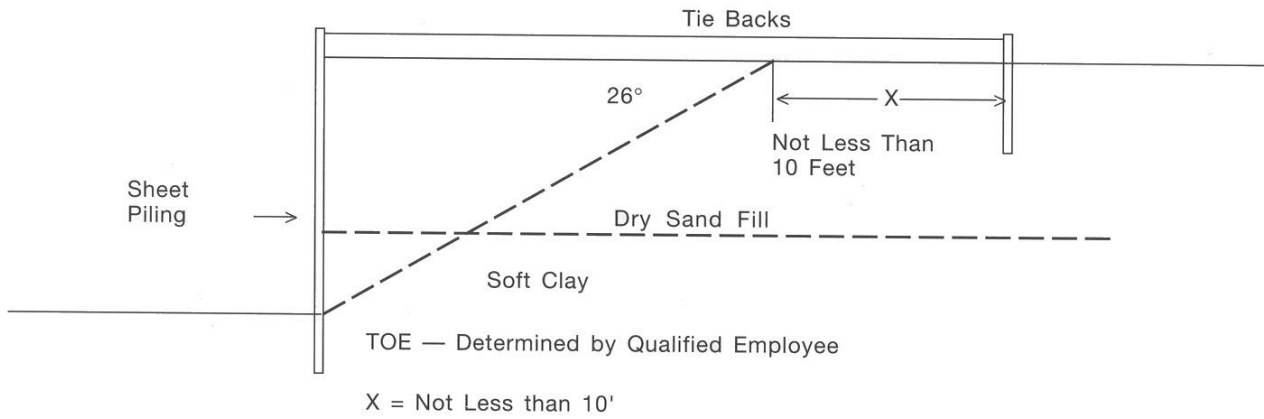

EXAMPLE 13

Trench — Saturated sand, soft clay, or organic soil encountered at depth under a fill.

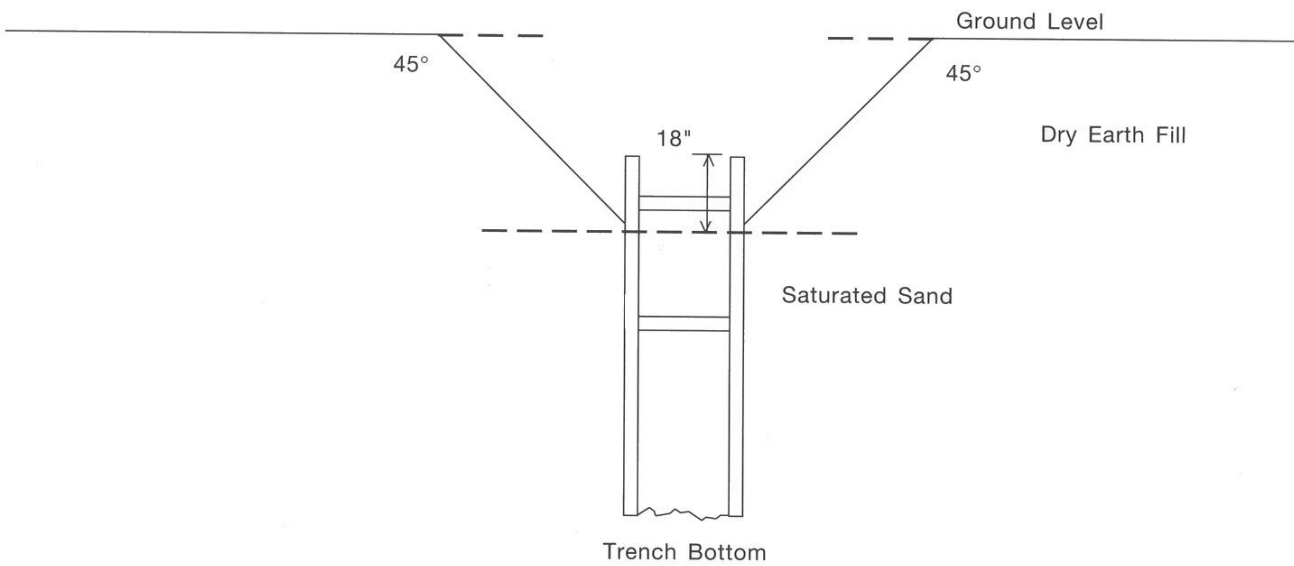

If the bottom of the trench extends into saturated sand, soft clay, or organic soil under a fill, a trench supporting system should be used to provide protection below the fill.



Michigan Occupational Safety and Health Administration
PO Box 30643
Lansing, Michigan 48909-8143
For technical questions of this standard – Ph: 517-284-7680 (CSHD) or 517-284-7720 (CETD)
To order copies of this standard – Ph: 517-284-7740

The Department of Labor and Economic Opportunity will not discriminate against any individual or group because of race, sex, religion, age, national origin, color, marital status, disability, or political beliefs. Auxiliary aids, services and other reasonable accommodations are available upon request to individuals with disabilities.