



DEPARTMENT OF LABOR AND ECONOMIC OPPORTUNITY

GENERAL INDUSTRY STANDARD

Filed with the Secretary of State on November 15, 1969 (as amended September 15, 1971)
(as amended August 13, 1973) (as amended August 2, 1976) (as amended April 2, 1979)
(as amended November 15, 1989) **(as amended January 26, 2018)**

These rules become effective immediately upon filing with the Secretary of State
unless adopted under section 33, 44, or 45a(6) of 1969 PA 306.

Rules adopted under these sections become effective 7 days after filing with the Secretary of State.

By authority conferred on the director of the department of licensing and regulatory affairs
by sections 16 and 21 of 1974 PA 154, MCL 408.1016 and 408.1021,
and Executive Reorganization Order Nos. 1996-2, 2003-1, 2008-4,
and 2011-4, MCL 445.2001, 445.2011, 445.2025, and 445.2030)

R 408.10201 and R 408.10205 of the Michigan Administrative Code are amended,
R 408.10202, R 408.10203, and R 408.10204, are added, and
R 408.10206, R 408.10207, R 408.10208, R 408.10211, R 408.10213, R 408.10215, R 408.10217, R 408.10219,
R 408.10220, R 408.10221, R 408.10223, R 408.10227, R 408.10228, R 408.10230, R 408.10231, R 408.10232,
R 408.10233, R 408.10235, R 408.10236, R 408.10237, R 408.10239, R 408.10240, and R 408.10241
are rescinded, as follows:

PART 2, WALKING-WORKING SURFACES

Table of Contents

R 408.10201 Scope.....	1	1910.23 Ladders.....	9
R 408.10202 Adoption of a federal standard.....	1	1910.24 Step Bolts and Manhole Steps.....	15
R 408.10203 Effective Dates.....	2	1910.25 Stairways.....	17
R 408.10204 Availability of OSHA adopted regulations.....	2	1910.26 Dockboards.....	21
.....	2	1910.27 Scaffolds and Rope Descent Systems ...	22
R 408.10205 MIOSHA referenced standards.....	2	1910.28 Duty To Have Fall Protection and Falling Object Protection.....	23
SUBPART D WALKING-WORKING SURFACES.....	4	1910.29 Fall Protection Systems and Falling Object Protection—Criteria And Practices.....	27
1910.21 Scope and Definitions.....	5	1910.30 Training Requirements.....	34
1910.22 General Requirements.....	8		

R 408.10201 Scope.

Rule 201. This standard applies to all general industry workplaces. It covers all walking-working surfaces unless specifically excluded by an individual section of this standard.

R 408.10202 Adoption of a federal standard.

Rule 202. (1) The federal Occupational Safety and Health Administration (OSHA) regulation 29 C.F.R. 1910 Subpart D “Walking-Working Surfaces,” as amended November 18, 2016, is adopted by reference in these rules.

(2) The regulation 29 C.F.R. 1910 Subpart D “Walking-Working Surfaces” includes all of the following:

- (a) 29 C.F.R. Part §1910.21 “Scope and definitions.”
- (b) 29 C.F.R. Part §1910.22 “General requirements.”
- (c) 29 C.F.R. Part §1910.23 “Ladders.”
- (d) 29 C.F.R. Part §1910.24 “Step bolts and manhole steps.”
- (e) 29 C.F.R. Part §1910.25 “Stairways.”
- (f) 29 C.F.R. Part §1910.26 “Dockboards.”
- (g) 29 C.F.R. Part §1910.27 “Scaffolds and rope descent systems.”
- (h) 29 C.F.R. Part §1910.28 “Duty to have fall protection and falling object protection.”
- (i) 29 C.F.R. Part §1910.29 “Fall protection systems and falling object protection—criteria and practices.”

(j) 29 C.F.R. Part §1910.30 “Training requirements.”

(3) A reference to §1910.66(j) “Powered platforms for building maintenance,” means General Industry Safety and Health Standard Part 5 “Powered Platforms for Building Maintenance,” R 408.10592.

(4) A reference to §1910.67(c)(2)(v) “Vehicle-mounted elevating and rotating work platforms,” means General Industry Safety and Health Standard Part 58 “Aerial Work Platforms,” R 408.15836(1).

(5) A reference to §1910.140 “Personal fall protection systems,” means General Industry Safety and Health Standard Part 33 “Personal Protective Equipment.”

(6) A reference to §1910.145 “Specifications for accident prevention signs and tags,” means General Industry Safety Standard Part 37 “Accident Prevention Signs and Tags.”

(7) A reference to §1910.268 “Telecommunications,” means General Industry Safety and Health Standard Part 50 “Telecommunications for General Industry.”

(8) A reference to §1910.269 “Electric Power Generation, Transmission, and Distribution,” means General Industry Safety and Health Standard Part 86 “Electric Power Generation, Transmission, and Distribution.”

(9) A reference to §1926.502 “Fall protection systems criteria and practices,” means Construction Safety Standard Part 45 “Fall Protection.”

(10) A reference to §1926.503 “Training requirements,” means Construction Safety Standard Part 45 “Fall Protection.”

(11) A reference to 1910 Subpart I “Personal Protective Equipment,” means General Industry Safety and Health Standard Part 33 “Personal Protective Equipment.”

(12) A reference to 1926 Subpart L “Scaffolds,” means Construction Safety Standard Part 12 “Scaffolds and Scaffold Platforms,” and Construction Safety Standard Part 32 “Aerial Work Platforms”

(13) A reference to 1926 Subpart M “Fall Protection,” means Construction Safety Standard Part 45 “Fall Protection.”

(14) The availability information for the OSHA standards adopted in these rules is in R 408.10204 and MIOSHA standards referenced in these rules are in R 408.10205.

(15) The adopted federal regulations shall have the same force and effect as a rule promulgated under the Michigan Occupational Safety and Health Act, 1974 PA 154, MCL 408.1001 to 408.1094.

R 408.10203 Effective Dates.

Rule 203. The following are the effective dates of the adopted OSHA standards in Michigan:

(a) A reference to January 17, 2017, means the effective date of this standard in Michigan, which is 7 days after filing with the Secretary of State.

(b) A reference to May 17, 2017, means four months after the effective date of this standard in Michigan, which is 7 days after filing with the Secretary of State.

(c) A reference to November 20, 2017, means 10 months after the effective date of this standard in Michigan, which is 7 days after filing with the Secretary of State.

(d) A reference to November 19, 2018, means November 19, 2018.

(e) A reference to November 18, 2036, means November 18, 2036.

R 408.10204 Availability of OSHA adopted regulations.

Rule 204. (1) The OSHA regulations adopted in these rules are available from the United States Department of Labor, Occupational Safety and Health Administration website: www.osha.gov, at no charge, as of the time of adoption of these rules.

(2) The regulations adopted in these rules are available for inspection at the Department of Licensing and Regulatory Affairs, MIOSHA Regulatory Services Section, 530 West Allegan Street, P.O. Box 30643, Lansing, Michigan, 48909-8143.

(3) The regulations adopted in these rules may be obtained from the publisher or may be obtained from the Department of Licensing and Regulatory Affairs, MIOSHA Regulatory Services Section, 530 West Allegan Street, P.O. Box 30643, Lansing, Michigan, 48909-8143, at the cost charged in this rule, plus \$20.00 for shipping and handling.

R 408.10205 MIOSHA referenced standards.

Rule 205. The following Michigan Occupational Safety and Health Administration (MIOSHA) standards are referenced in these rules. Up to 5 copies of these standards may be obtained at no charge from the Michigan Department of Licensing and Regulatory Affairs, MIOSHA Regulatory Services Section, 530 West Allegan Street, P.O. Box 30643, Lansing, Michigan, 48909-8143 or via the internet at website: www.michigan.gov/mioshastandards. For quantities greater than 5, the cost, at the time of adoption of these rules, is 4 cents per page.

(a) Construction Safety Standard Part 12 “Scaffolds and Scaffold Platforms,” R 408.41201 to R 408.41264.

(b) Construction Safety Standard Part 32 “Aerial Work Platforms,” R 408.43201 to R 408.43220.

(c) Construction Safety Standard Part 45 “Fall Protection,” R 408.44501 to R 408.44502.

(d) General Industry Safety and Health Standard Part 5 "Powered Platforms for Building Maintenance," R 408.10501 to R 408.10592.

(e) General Industry Safety and Health Standard Part 33 "Personal Protective Equipment," R 408.13301 to R 408.13398.

(f) General Industry Safety Standard Part 37 "Accident Prevention Signs and Tags," R 408.13701 to R 408.13738.

(g) General Industry Safety and Health Standard Part 50 "Telecommunications for General Industry," R 408.15001 to R 408.15004.

(h) General Industry Safety and Health Standard Part 58 "Aerial Work Platforms," R 408.15801 to R 408.15842.

(i) General Industry Safety and Health Standard Part 86 "Electric Power Generation, Transmission, and Distribution," R 408.18601 to R 408.18605.

29 C.F.R. 1910 SUBPART D WALKING-WORKING SURFACES

Table of Contents

1910.21 SCOPE AND DEFINITIONS	5
(a) Scope.....	5
(b) Definitions.....	5
1910.22 GENERAL REQUIREMENTS	8
(a) Surface conditions.....	8
(b) Loads.....	8
(c) Access and egress.....	8
(d) Inspection, maintenance, and repair.....	8
1910.23 LADDERS	9
(a) Application.....	9
(b) General requirements for all ladders.....	9
(c) Portable ladders.....	9
(d) Fixed ladders.....	10
(e) Mobile ladder stands and mobile ladder stand platforms.....	14
1910.24 STEP BOLTS AND MANHOLE STEPS	15
(a) Step bolts.....	15
(b) Manhole steps.....	16
1910.25 STAIRWAYS	17
(a) Application.....	17
(b) General requirements.....	17
(c) Standard stairs.....	17
(d) Spiral stairs.....	19
(e) Ship stairs.....	19
(f) Alternating tread-type stairs.....	19
1910.26 DOCKBOARDS	21
1910.27 SCAFFOLDS AND ROPE DESCENT SYSTEMS	22
(a) Scaffolds.....	22
(b) Rope descent systems.....	22
1910.28 DUTY TO HAVE FALL PROTECTION AND FALLING OBJECT PROTECTION	23
(a) General.....	23
(b) Protection from fall hazards.....	23
(c) Protection from falling objects.....	26
1910.29 FALL PROTECTION SYSTEMS AND FALLING OBJECT PROTECTION—CRITERIA AND PRACTICES	27
(a) General requirements.....	27
(b) Guardrail systems.....	27
(c) Safety net systems.....	28
(d) Designated areas.....	28
(e) Covers.....	28
(f) Handrails and stair rail systems.....	29
(g) Cages, wells, and platforms used with fixed ladders.....	30
(h) Outdoor advertising.....	30
(i) Ladder safety systems.....	33
(j) Personal fall protection systems.....	33
(k) Protection from falling objects.....	33
(l) Grab handles.....	33
1910.30 TRAINING REQUIREMENTS	34
(a) Fall hazards.....	34
(b) Equipment hazards.....	34
(c) Retraining.....	34
(d) Training must be understandable.....	34

1910.21 SCOPE AND DEFINITIONS

(a) Scope. This subpart applies to all general industry workplaces. It covers all walking-working surfaces unless specifically excluded by an individual section of this subpart.

(b) Definitions. The following definitions apply in this subpart:

Alternating tread-type stair means a type of stairway consisting of a series of treads that usually are attached to a center support in an alternating manner such that an employee typically does not have both feet on the same level while using the stairway.

Anchorage means a secure point of attachment for equipment such as lifelines, lanyards, deceleration devices, and rope descent systems.

Authorized means an employee who the employer assigns to perform a specific type of duty, or allows in a specific location or area.

Cage means an enclosure mounted on the side rails of a fixed ladder or fastened to a structure behind the fixed ladder that is designed to surround the climbing space of the ladder. A cage also is called a "cage guard" or "basket guard."

Carrier means the track of a ladder safety system that consists of a flexible cable or rigid rail attached to the fixed ladder or immediately adjacent to it.

Combination ladder means a portable ladder that can be used as a stepladder, extension ladder, trestle ladder, or stairway ladder. The components of a combination ladder also may be used separately as a single ladder.

Dangerous equipment means equipment, such as vats, tanks, electrical equipment, machinery, equipment or machinery with protruding parts, or other similar units, that, because of their function or form, may harm an employee who falls into or onto the equipment.

Designated area means a distinct portion of a walking-working surface delineated by a warning line in which employees may perform work without additional fall protection.

Dockboard means a portable or fixed device that spans a gap or compensates for a difference in elevation between a loading platform and a transport vehicle. Dockboards include, but are not limited to, bridge plates, dock plates, and dock levelers.

Equivalent means alternative designs, equipment, materials, or methods, that the employer can demonstrate will provide an equal or greater degree of safety for employees compared to the designs, equipment, materials, or methods specified in this subpart.

Extension ladder means a non-self-supporting portable ladder that is adjustable in length.

Failure means a load refusal, breakage, or separation of component parts. A load refusal is the point at which the ultimate strength of a component or object is exceeded.

Fall hazard means any condition on a walking-working surface that exposes an employee to a risk of harm from a fall on the same level or to a lower level.

Fall protection means any equipment, device, or system that prevents an employee from falling from an elevation or mitigates the effect of such a fall.

Fixed ladder means a ladder with rails or individual rungs that is permanently attached to a structure, building, or equipment. Fixed ladders include individual-rung ladders, but not ship stairs, step bolts, or manhole steps.

Grab bar means an individual horizontal or vertical handhold installed to provide access above the height of the ladder.

Guardrail system means a barrier erected along an unprotected or exposed side, edge, or other area of a walking-working surface to prevent employees from falling to a lower level.

Handrail means a rail used to provide employees with a handhold for support.

Hoist area means any elevated access opening to a walking-working surface through which equipment or materials are loaded or received.

Hole means a gap or open space in a floor, roof, horizontal walking-working surface, or similar surface that is at least 2 inches (5 cm) in its least dimension.

Individual-rung ladder means a ladder that has rungs individually attached to a building or structure. An individual-rung ladder does not include manhole steps.

Ladder means a device with rungs, steps, or cleats used to gain access to a different elevation.

Ladder safety system means a system designed to eliminate or reduce the possibility of falling from a ladder. A ladder safety system usually consists of a carrier, safety sleeve, lanyard, connectors, and body harness. Cages and wells are not ladder safety systems.

Low-slope roof means a roof that has a slope less than or equal to a ratio of 4 in 12 (vertical to horizontal).

Lower level means a surface or area to which an employee could fall. Such surfaces or areas include, but are not limited to, ground levels, floors, roofs, ramps, runways, excavations, pits, tanks, materials, water, equipment, and similar surfaces and structures, or portions thereof.

Manhole steps means steps that are individually attached to, or set into, the wall of a manhole structure.

Maximum intended load means the total load (weight and force) of all employees, equipment, vehicles, tools, materials, and other loads the employer reasonably anticipates to be applied to a walking-working surface at any one time.

Mobile means manually propelled or moveable.

Mobile ladder stand (ladder stand) means a mobile, fixed-height, self-supporting ladder that usually consists of wheels or casters on a rigid base and steps leading to a top step. A mobile ladder stand also may have handrails and is designed for use by one employee at a time.

Mobile ladder stand platform means a mobile, fixed-height, self-supporting unit having one or more standing platforms that are provided with means of access or egress.

Open riser means the gap or space between treads of stairways that do not have upright or inclined members (risers).

Opening means a gap or open space in a wall, partition, vertical walking-working surface, or similar surface that is at least 30 inches (76 cm) high and at least 18 inches (46 cm) wide, through which an employee can fall to a lower level.

Personal fall arrest system means a system used to arrest an employee in a fall from a walking-working surface. It consists of a body harness, anchorage, and connector. The means of connection may include a lanyard, deceleration device, lifeline, or a suitable combination of these.

Personal fall protection system means a system (including all components) an employer uses to provide protection from falling or to safely arrest an employee's fall if one occurs. Examples of personal fall protection systems include personal fall arrest systems, positioning systems, and travel restraint systems.

Platform means a walking-working surface that is elevated above the surrounding area.

Portable ladder means a ladder that can readily be moved or carried, and usually consists of side rails joined at intervals by steps, rungs, or cleats.

Positioning system (work-positioning system) means a system of equipment and connectors that, when used with a body harness or body belt, allows an employee to be supported on an elevated vertical surface, such as a wall or window sill, and work with both hands free. Positioning systems also are called "positioning system devices" and "work-positioning equipment."

Qualified describes a person who, by possession of a recognized degree, certificate, or professional standing, or who by extensive knowledge, training, and experience has successfully demonstrated the ability to solve or resolve problems relating to the subject matter, the work, or the project.

Ramp means an inclined walking-working surface used to access another level.

Riser means the upright (vertical) or inclined member of a stair that is located at the back of a stair tread or platform and connects close to the front edge of the next higher tread, platform, or landing.

Rope descent system means a suspension system that allows an employee to descend in a controlled manner and, as needed, stop at any point during the descent. A rope descent system usually consists of a roof anchorage, support rope, a descent device, carabiner(s) or shackle(s), and a chair (seat-board). A rope descent system also is called controlled descent equipment or apparatus. Rope descent systems do not include industrial rope access systems.

Rung, step, or cleat means the crosspiece of a ladder on which an employee steps to climb up and down.

Runway means an elevated walking-working surface, such as a catwalk, a foot walk along shafting, or an elevated walkway between buildings.

Scaffold means any temporary elevated or suspended platform and its supporting structure, including anchorage points, used to support employees, equipment, materials, and other items. For purposes of this subpart, a scaffold does not include a crane-suspended or derrick-suspended personnel platform or a rope descent system.

Ship stair (ship ladder) means a stairway that is equipped with treads, stair rails, and open risers, and has a slope that is between 50 and 70 degrees from the horizontal.

Side-step ladder means a type of fixed ladder that requires an employee to step sideways from it in order to reach a walking-working surface, such as a landing.

Spiral stairs means a series of treads attached to a vertical pole in a winding fashion, usually within a cylindrical space.

Stair rail or stair rail system means a barrier erected along the exposed or open side of stairways to prevent employees from falling to a lower level.

Stairway (stairs) means risers and treads that connect one level with another, and includes any landings and platforms in between those levels. Stairways include standard, spiral, alternating tread-type, and ship stairs.

Standard stairs means a fixed or permanently installed stairway. Ship, spiral, and alternating tread-type stairs are not considered standard stairs.

Step bolt (pole step) means a bolt or rung attached at intervals along a structural member used for foot placement and as a handhold when climbing or standing.

Stepladder means a self-supporting, portable ladder that has a fixed height, flat steps, and a hinged back.

Stepstool means a self-supporting, portable ladder that has flat steps and side rails. For purposes of the final rule, stepstool includes only those ladders that have a fixed height, do not have a pail shelf, and do not exceed 32 inches (81 cm) in overall height to the top cap, although side rails may extend above the top cap. A stepstool is designed so an employee can climb and stand on all of the steps and the top cap.

Through ladder means a type of fixed ladder that allows the employee to step through the side rails at the top of the ladder to reach a walking-working surface, such as a landing.

Tieback means an attachment between an anchorage (e.g., structural member) and a supporting device (e.g., parapet clamp or cornice hook).

Toeboard means a low protective barrier that is designed to prevent materials, tools, and equipment from falling to a lower level, and protect employees from falling.

Travel restraint system means a combination of an anchorage, anchorage connector, lanyard (or other means of connection), and body support that an employer uses to eliminate the possibility of an employee going over the edge of a walking-working surface.

Tread means a horizontal member of a stair or stairway, but does not include landings or platforms

Unprotected sides and edges mean any side or edge of a walking-working surface (except at entrances and other points of access) where there is no wall, guardrail system, or stair rail system to protect an employee from falling to a lower level.

Walking-working surface means any horizontal or vertical surface on or through which an employee walks, works, or gains access to a work area or workplace location.

Warning line means a barrier erected to warn employees that they are approaching an unprotected side or edge, and which designates an area in which work may take place without the use of other means of fall protection.

Well means a permanent, complete enclosure around a fixed ladder.

[81 FR 82981-82983, Nov. 18, 2016]

1910.22 GENERAL REQUIREMENTS

(a) Surface conditions. The employer must ensure:

(1) All places of employment, passageways, storerooms, service rooms, and walking-working surfaces are kept in a clean, orderly, and sanitary condition.

(2) The floor of each workroom is maintained in a clean and, to the extent feasible, in a dry condition. When wet processes are used, drainage must be maintained and, to the extent feasible, dry standing places, such as false floors, platforms, and mats must be provided.

(3) Walking-working surfaces are maintained free of hazards such as sharp or protruding objects, loose boards, corrosion, leaks, spills, snow, and ice.

(b) Loads. The employer must ensure that each walking-working surface can support the maximum intended load for that surface.

(c) Access and egress. The employer must provide, and ensure each employee uses, a safe means of access and egress to and from walking-working surfaces.

(d) Inspection, maintenance, and repair. The employer must ensure:

(1) Walking-working surfaces are inspected, regularly and as necessary, and maintained in a safe condition;

(2) Hazardous conditions on walking-working surfaces are corrected or repaired before an employee uses the walking-working surface again. If the correction or repair cannot be made immediately, the hazard must be guarded to prevent employees from using the walking-working surface until the hazard is corrected or repaired; and

(3) When any correction or repair involves the structural integrity of the walking-working surface, a qualified person performs or supervises the correction or repair.

[81 FR 82983, Nov. 18, 2016]

1910.23 LADDERS

(a) Application. The employer must ensure that each ladder used meets the requirements of this section. This section covers all ladders, except when the ladder is:

- (1) Used in emergency operations such as firefighting, rescue, and tactical law enforcement operations, or training for these operations; or
- (2) Designed into or is an integral part of machines or equipment.

(b) General requirements for all ladders. The employer must ensure:

- (1) Ladder rungs, steps, and cleats are parallel, level, and uniformly spaced when the ladder is in position for use;
- (2) Ladder rungs, steps, and cleats are spaced not less than 10 inches (25 cm) and not more than 14 inches (36 cm) apart, as measured between the centerlines of the rungs, cleats, and steps, except that:
 - (i) Ladder rungs and steps in elevator shafts must be spaced not less than 6 inches (15 cm) apart and not more than 16.5 inches (42 cm) apart, as measured along the ladder side rails; and
 - (ii) Fixed ladder rungs and steps on telecommunication towers must be spaced not more than 18 inches (46 cm) apart, measured between the centerlines of the rungs or steps;
- (3) Steps on stepstools are spaced not less than 8 inches (20 cm) apart and not more than 12 inches (30 cm) apart, as measured between the centerlines of the steps;
- (4) Ladder rungs, steps, and cleats have a minimum clear width of 11.5 inches (29 cm) on portable ladders and 16 inches (41 cm) (measured before installation of ladder safety systems) for fixed ladders, except that:
 - (i) The minimum clear width does not apply to ladders with narrow rungs that are not designed to be stepped on, such as those located on the tapered end of orchard ladders and similar ladders;
 - (ii) Rungs and steps of manhole entry ladders that are supported by the manhole opening must have a minimum clear width of 9 inches (23 cm);
 - (iii) Rungs and steps on rolling ladders used in telecommunication centers must have a minimum clear width of 8 inches (20 cm); and
 - (iv) Stepstools have a minimum clear width of 10.5 inches (26.7 cm);
- (5) Wooden ladders are not coated with any material that may obscure structural defects;
- (6) Metal ladders are made with corrosion-resistant material or protected against corrosion;
- (7) Ladder surfaces are free of puncture and laceration hazards;
- (8) Ladders are used only for the purposes for which they were designed;

(9) Ladders are inspected before initial use in each work shift, and more frequently as necessary, to identify any visible defects that could cause employee injury;

(10) Any ladder with structural or other defects is immediately tagged "Dangerous: Do Not Use" or with similar language in accordance with § 1910.145 and removed from service until repaired in accordance with § 1910.22(d), or replaced;

(11) Each employee faces the ladder when climbing up or down it;

(12) Each employee uses at least one hand to grasp the ladder when climbing up and down it; and

(13) No employee carries any object or load that could cause the employee to lose balance and fall while climbing up or down the ladder.

(c) Portable ladders. The employer must ensure:

(1) Rungs and steps of portable metal ladders are corrugated, knurled, dimpled, coated with skid-resistant material, or otherwise treated to minimize the possibility of slipping;

(2) Each stepladder or combination ladder used in a stepladder mode is equipped with a metal spreader or locking device that securely holds the front and back sections in an open position while the ladder is in use;

(3) Ladders are not loaded beyond the maximum intended load;

Note to paragraph (c)(3): The maximum intended load, as defined in § 1910.21(b), includes the total load (weight and force) of the employee and all tools, equipment, and materials being carried.

(4) Ladders are used only on stable and level surfaces unless they are secured or stabilized to prevent accidental displacement;

(5) No portable single rail ladders are used;

(6) No ladder is moved, shifted, or extended while an employee is on it;

(7) Ladders placed in locations such as passageways, doorways, or driveways where they can be displaced by other activities or traffic:

(i) Are secured to prevent accidental displacement; or

(ii) Are guarded by a temporary barricade, such as a row of traffic cones or caution tape, to keep the activities or traffic away from the ladder;

(8) The cap (if equipped) and top step of a stepladder are not used as steps;

(9) Portable ladders used on slippery surfaces are secured and stabilized;

(10) The top of a non-self-supporting ladder is placed so that both side rails are supported, unless the ladder is equipped with a single support attachment;

(11) Portable ladders used to gain access to an upper landing surface have side rails that extend at least 3 feet (0.9 m) above the upper landing surface (see Figure D-1 of this section);

(12) Ladders and ladder sections are not tied or fastened together to provide added length unless they are specifically designed for such use;

(13) Ladders are not placed on boxes, barrels, or other unstable bases to obtain additional height.

Figure D-1 -- Portable Ladder Set-Up

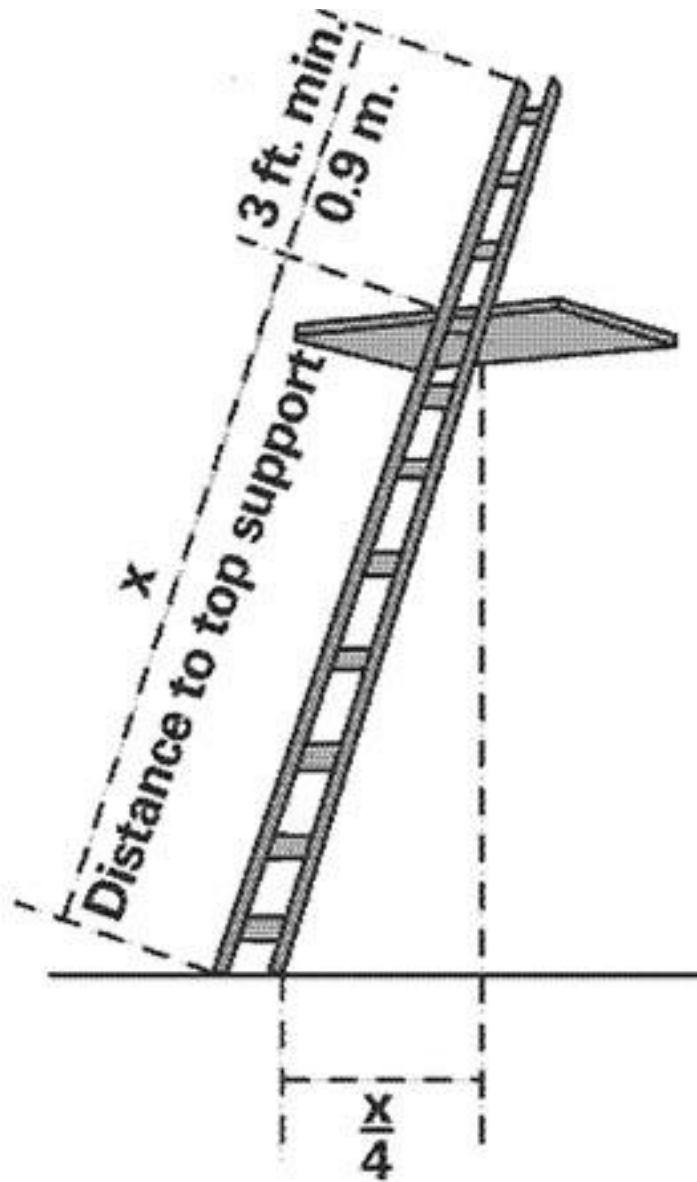

(d) Fixed ladders. The employer must ensure:

(1) Fixed ladders are capable of supporting their maximum intended load;

(2) The minimum perpendicular distance from the centerline of the steps or rungs, or grab bars, or both, to the nearest permanent object in back of the ladder is 7 inches (18 cm), except for elevator pit ladders, which have a minimum perpendicular distance of 4.5 inches (11 cm);

(3) Grab bars do not protrude on the climbing side beyond the rungs of the ladder that they serve;

(4) The side rails of through or sidestep ladders extend 42 inches (1.1 m) above the top of the access level or landing platform served by the ladder. For parapet ladders, the access level is:

(i) The roof, if the parapet is cut to permit passage through the parapet; or

(ii) The top of the parapet, if the parapet is continuous;

(5) For through ladders, the steps or rungs are omitted from the extensions, and the side rails are flared to provide not less than 24 inches (61 cm) and not more than 30 inches (76 cm) of clearance. When a ladder safety system is provided, the maximum clearance between side rails of the extension must not exceed 36 inches (91 cm);

(6) For side-step ladders, the side rails, rungs, and steps must be continuous in the extension (see Figure D-2 of this section);

(7) Grab bars extend 42 inches (1.1 m) above the access level or landing platforms served by the ladder;

(8) The minimum size (cross-section) of grab bars is the same size as the rungs of the ladder.

(9) When a fixed ladder terminates at a hatch (see Figure D-3 of this section), the hatch cover:

(i) Opens with sufficient clearance to provide easy access to or from the ladder; and

(ii) Opens at least 70 degrees from horizontal if the hatch is counterbalanced;

(10) Individual-rung ladders are constructed to prevent the employee's feet from sliding off the ends of the rungs (see Figure D-4 of this section);

(11) Fixed ladders having a pitch greater than 90 degrees from the horizontal are not used;

(12) The step-across distance from the centerline of the rungs or steps is:

(i) For through ladders, not less than 7 inches (18 cm) and not more than 12 inches (30 cm) to the nearest edge of the structure, building, or equipment accessed from the ladders;

(ii) For side-step ladders, not less than 15 inches (38 cm) and not more than 20 inches (51 cm) to the access points of the platform edge;

(13) Fixed ladders that do not have cages or wells have:

(i) A clear width of at least 15 inches (38 cm) on each side of the ladder centerline to the nearest permanent object; and

(ii) A minimum perpendicular distance of 30 inches (76 cm) from the centerline of the steps or rungs to the nearest object on the climbing side. When unavoidable obstructions are encountered, the minimum clearance at the obstruction may be reduced to 24 inches (61 cm), provided deflector plates are installed (see Figure D-5 of this section).

Note to paragraph (d): Section 1910.28 establishes the employer's duty to provide fall protection for employees on fixed ladders, and § 1910.29 specifies the criteria for fall protection systems for fixed ladders.

Figure D-2 -- Side-Step Fixed Ladder Sections

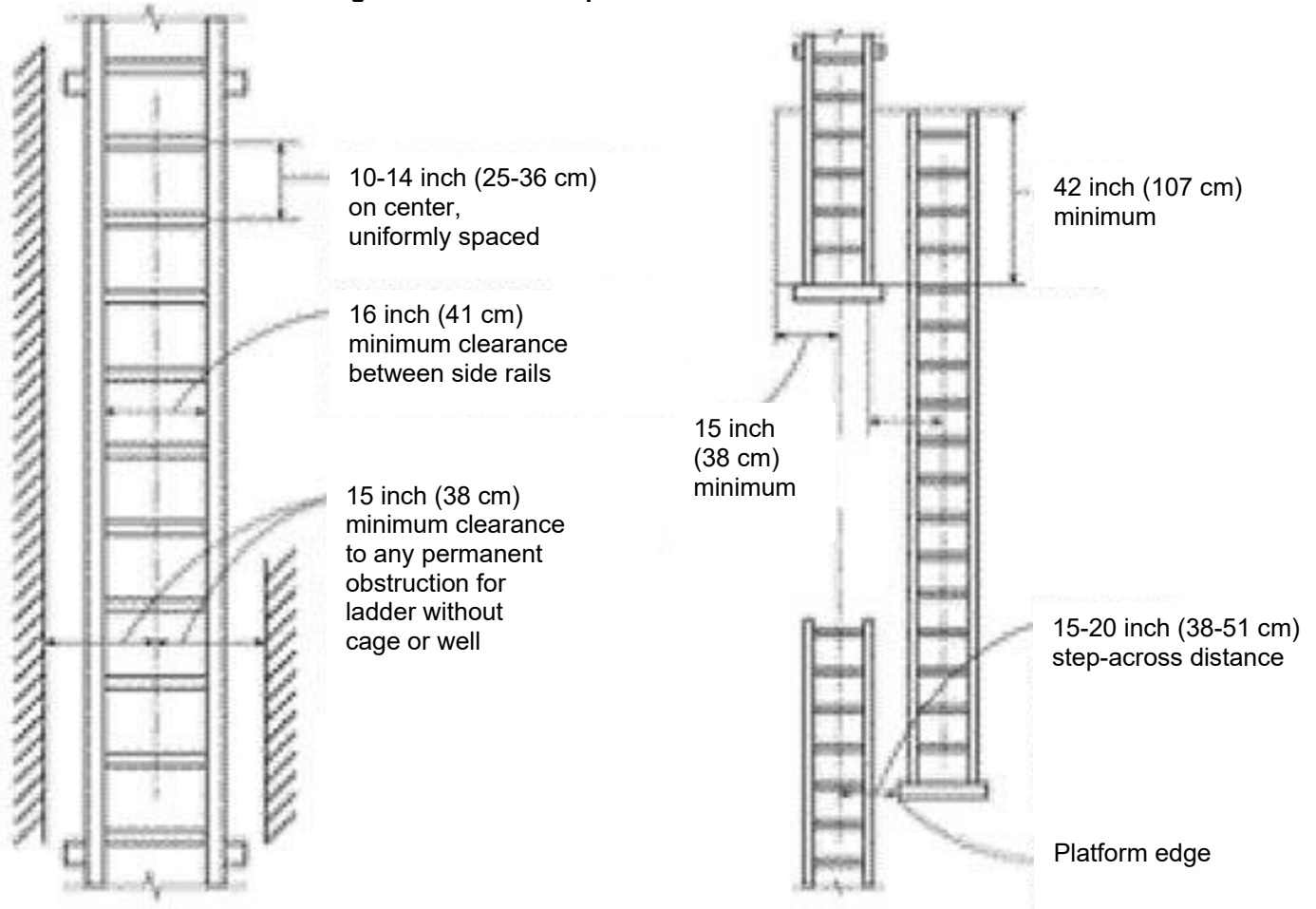

FIXED LADDER DIMENSIONS AND SIDE CLEARANCES

SIDE CLEARANCES FOR SIDE-STEP LADDERS

Figure D-3 – Example of Counterbalanced Hatch Cover at Roof

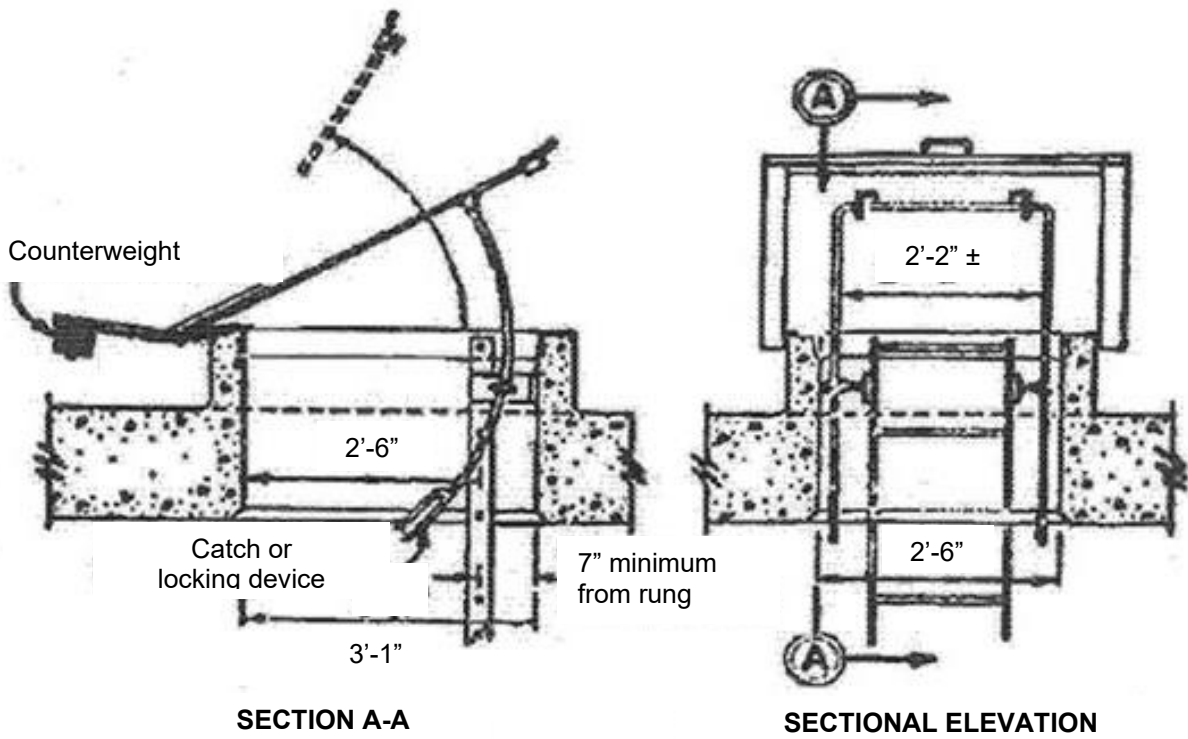

Figure D-4 -- Individual Rung Ladder

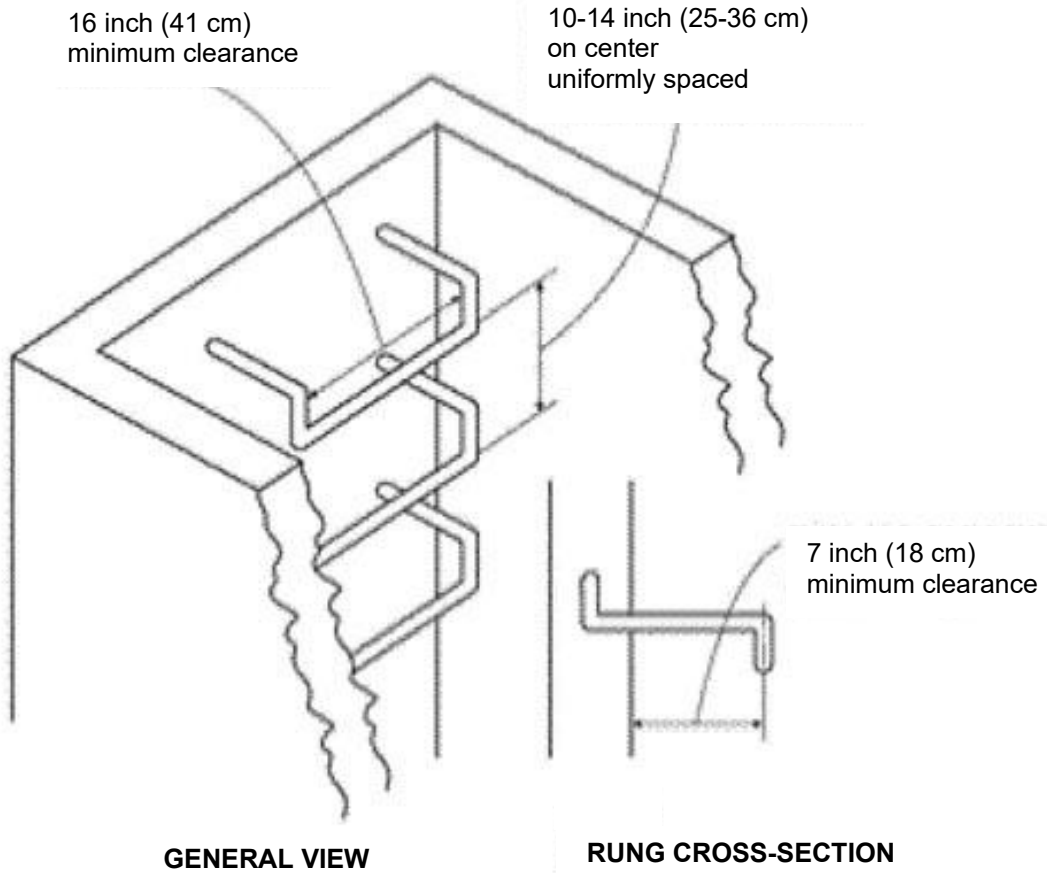
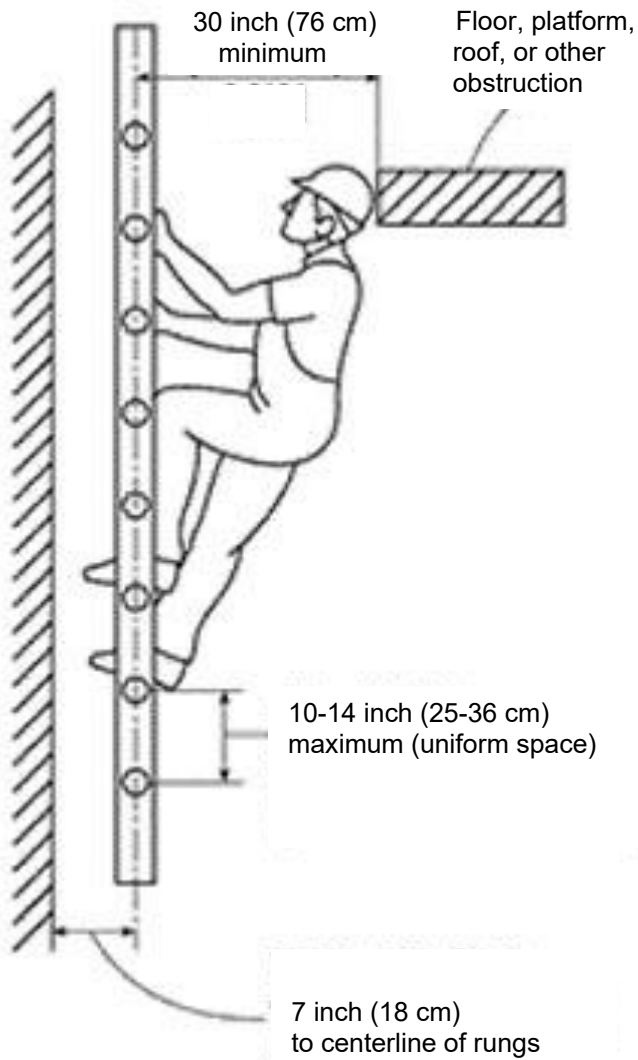
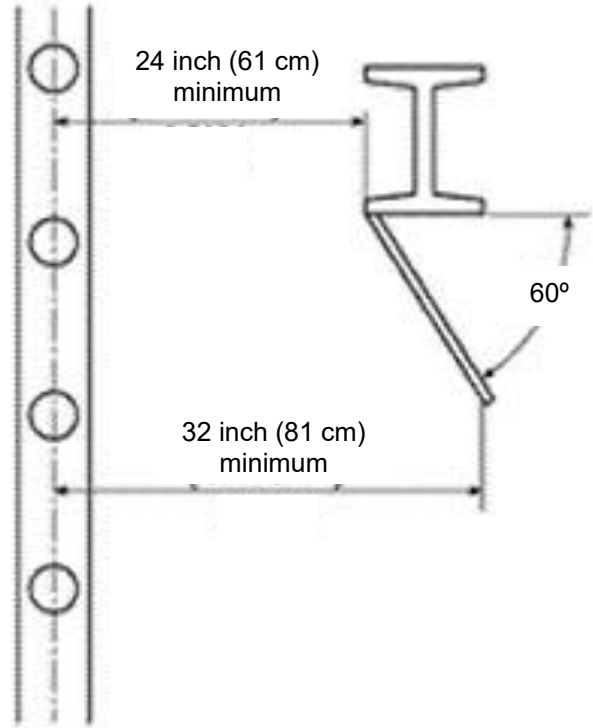

Figure D-5 -- Fixed Ladder Clearances



NORMAL CLEARANCE



**REDUCED CLEARANCE
DEFLECTOR PLATE
FOR HEAD HAZARDS**

(e) Mobile ladder stands and mobile ladder stand platforms.

(1) General requirements. The employer must ensure:

(i) Mobile ladder stands and platforms have a step width of at least 16 inches (41 cm);

(ii) The steps and platforms of mobile ladder stands and platforms are slip resistant. Slip-resistant surfaces must be either an integral part of the design and construction of the mobile ladder stand and platform, or provided as a secondary process or operation, such as dimpling, knurling, shot-blasting, coating, spraying, or applying durable slip-resistant tapes;

(iii) Mobile ladder stands and platforms are capable of supporting at least four times their maximum intended load;

(iv) Wheels or casters under load are capable of supporting their proportional share of four times the maximum intended load, plus their proportional share of the unit's weight;

(v) Unless otherwise specified in this section, mobile ladder stands and platforms with a top step height of 4 feet (1.2 m) or above have handrails with a vertical height of 29.5 inches (75 cm) to 37 inches (94 cm), measured from the front edge of a step. Removable gates or non-rigid members, such as chains, may be used instead of handrails in special use applications;

(vi) The maximum work-surface height of mobile ladder stands and platforms does not exceed four times the shortest base dimension, without additional support. For greater heights, outriggers, counterweights, or comparable means that stabilize the mobile ladder stands and platforms and prevent overturning must be used;

(vii) Mobile ladder stands and platforms that have wheels or casters are equipped with a system to impede horizontal movement when an employee is on the stand or platform; and

(viii) No mobile ladder stand or platform moves when an employee is on it.

(2) Design requirements for mobile ladder stands. The employer must ensure:

(i) Steps are uniformly spaced and arranged, with a rise of not more than 10 inches (25 cm) and a depth of not less than 7 inches (18 cm). The slope of the step stringer to which the steps are attached must not be more than 60 degrees, measured from the horizontal;

(ii) Mobile ladder stands with a top step height above 10 feet (3 m) have the top step protected on three sides by a handrail with a vertical height of at least 36 inches (91 cm); and top steps that are 20 inches (51 cm) or more, front to back, have a midrail and toeboard. Removable gates or non-rigid members, such as chains, may be used instead of handrails in special-use applications; and

(iii) The standing area of mobile ladder stands is within the base frame.

(3) Design requirements for mobile ladder stand platforms. The employer must ensure:

(i) Steps of mobile ladder stand platforms meet the requirements of paragraph (e)(2)(i) of this section. When the employer demonstrates that the requirement is not feasible, steeper slopes or vertical rung ladders may be used, provided the units are stabilized to prevent overturning;

(ii) Mobile ladder stand platforms with a platform height of 4 to 10 feet (1.2 m to 3 m) have, in the platform area, handrails with a vertical height of at least 36 inches (91 cm) and mid-rails; and

(iii) All ladder stand platforms with a platform height above 10 feet (3 m) have guardrails and toeboards on the exposed sides and ends of the platform.

(iv) Removable gates or non-rigid members, such as chains, may be used on mobile ladder stand platforms instead of handrails and guardrails in special-use applications.

[39 FR 23502, June 27, 1974, as amended at 43 FR 49744, Oct. 24, 1978; 49 FR 5321, Feb. 10, 1984; 81 FR 82983-82986, Nov. 18, 2016]

1910.24 STEP BOLTS AND MANHOLE STEPS

(a) **Step bolts.** The employer must ensure:

(1) Each step bolt installed on or after January 17, 2017 in an environment where corrosion may occur is constructed of, or coated with, material that protects against corrosion;

(2) Each step bolt is designed, constructed, and maintained to prevent the employee's foot from slipping off the end of the step bolt;

(3) Step bolts are uniformly spaced at a vertical distance of not less than 12 inches (30 cm) and not more than 18 inches (46 cm) apart, measured center to center (see Figure D-6 of this section). The spacing from the entry and exit surface to the first step bolt may differ from the spacing between the other step bolts;

(4) Each step bolt has a minimum clear width of 4.5 inches (11 cm);

(5) The minimum perpendicular distance between the centerline of each step bolt to the nearest permanent object in back of the step bolt is 7 inches (18 cm). When the employer demonstrates that an obstruction cannot be avoided, the distance must be at least 4.5 inches (11 cm);

(6) Each step bolt installed before January 17, 2017 is capable of supporting its maximum intended load;

(7) Each step bolt installed on or after January 17, 2017 is capable of supporting at least four times its maximum intended load;

(8) Each step bolt is inspected at the start of the workshift and maintained in accordance with § 1910.22; and

(9) Any step bolt that is bent more than 15 degrees from the perpendicular in any direction is removed and replaced with a step bolt that meets the requirements of this section before an employee uses it.

Figure D-6 -- Step Bolt Spacing

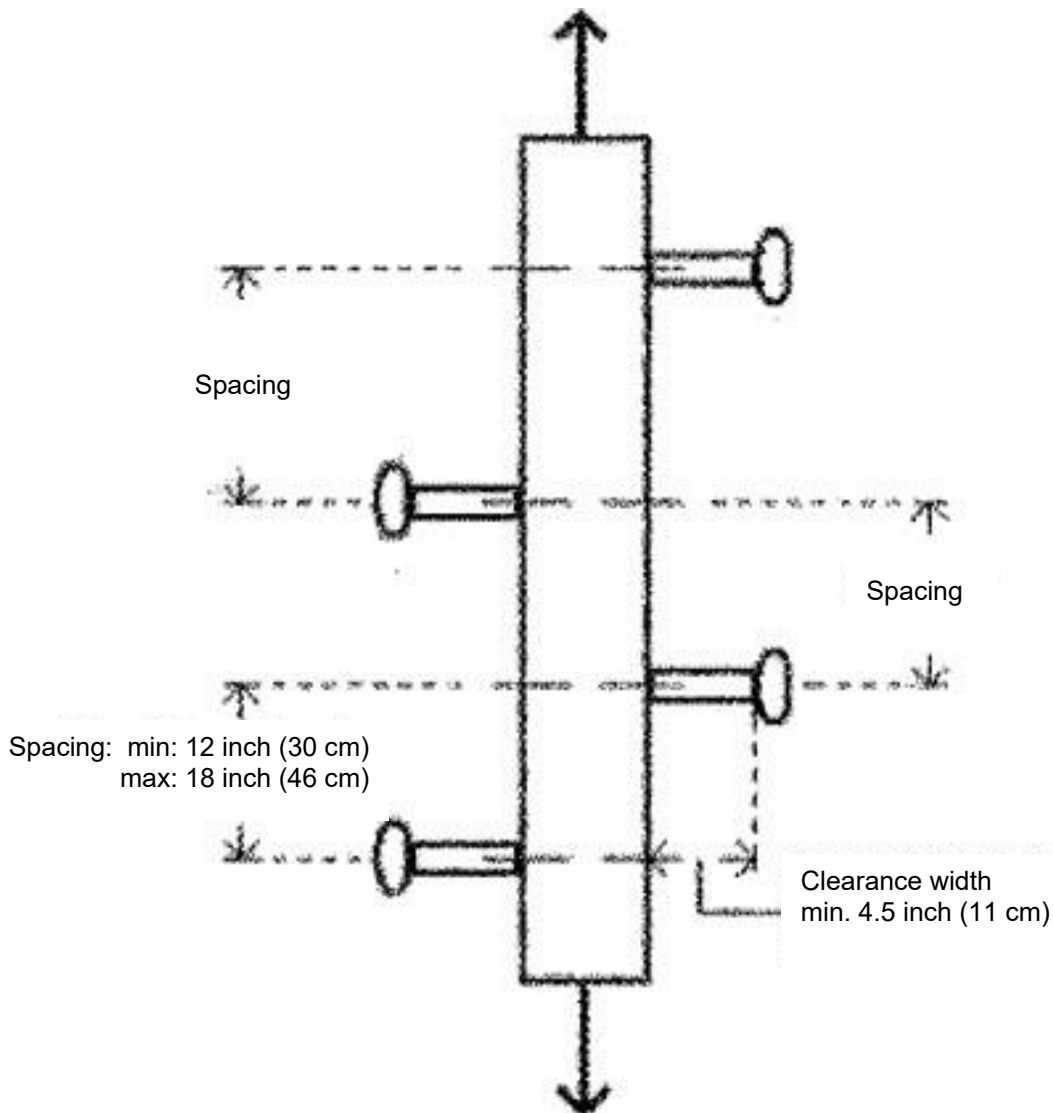

(b) Manhole steps.

(1) The employer must ensure that each manhole step is capable of supporting its maximum intended load.

(2) The employer must ensure that each manhole step installed on or after January 17, 2017:

(i) Has a corrugated, knurled, dimpled, or other surface that minimizes the possibility of an employee slipping;

(ii) Is constructed of, or coated with, material that protects against corrosion if the manhole step is located in an environment where corrosion may occur;

(iii) Has a minimum clear step width of 10 inches (25 cm);

(iv) Is uniformly spaced at a vertical distance not more than 16 inches (41 cm) apart, measured center to center between steps. The spacing from the entry and exit surface to the first manhole step may differ from the spacing between the other steps.

(v) Has a minimum perpendicular distance between the centerline of the manhole step to the nearest permanent object in back of the step of at least 4.5 inches (11 cm); and

(vi) Is designed, constructed, and maintained to prevent the employee's foot from slipping or sliding off the end.

(3) The employer must ensure that each manhole step is inspected at the start of the work shift and maintained in accordance with § 1910.22.

[39 FR 23502, June 27, 1974, as amended at 43 FR 49744, Oct. 24, 1978; 49 FR 5321, Feb. 10, 1984; 81 FR 82986-82987, Nov. 18, 2016]

1910.25 STAIRWAYS

(a) Application. This section covers all stairways (including standard, spiral, ship, and alternating tread-type stairs), except for stairs serving floating roof tanks, stairs on scaffolds, stairs designed into machines or equipment, and stairs on self-propelled motorized equipment.

(b) General requirements. The employer must ensure:

- (1) Handrails, stair rail systems, and guardrail systems are provided in accordance with § 1910.28;
- (2) Vertical clearance above any stair tread to any overhead obstruction is at least 6 feet, 8 inches (203 cm), as measured from the leading edge of the tread. Spiral stairs must meet the vertical clearance requirements in paragraph (d)(3) of this section.
- (3) Stairs have uniform riser heights and tread depths between landings;
- (4) Stairway landings and platforms are at least the width of the stair and at least 30 inches (76 cm) in depth, as measured in the direction of travel;
- (5) When a door or a gate opens directly on a stairway, a platform is provided, and the swing of the door or gate does not reduce the platform's effective usable depth to:

(i) Less than 20 inches (51 cm) for platforms installed before January 17, 2017; and

(ii) Less than 22 inches (56 cm) for platforms installed on or after January 17, 2017 (see Figure D-7 of this section);

(6) Each stair can support at least five times the normal anticipated live load, but never less than a concentrated load of 1,000 pounds (454 kg) applied at any point;

(7) Standard stairs are used to provide access from one walking-working surface to another when operations necessitate regular and routine travel between levels, including access to operating platforms for equipment. Winding stairways may be used on tanks and similar round structures when the diameter of the tank or structure is at least 5 feet (1.5 m).

(8) Spiral, ship, or alternating tread-type stairs are used only when the employer can demonstrate that it is not feasible to provide standard stairs.

(9) When paragraph (b)(8) of this section allows the use of spiral, ship, or alternating tread-type stairs, they are installed, used, and maintained in accordance with manufacturer's instructions.

Figure D-7 -- Door or Gate Opening on Stairway

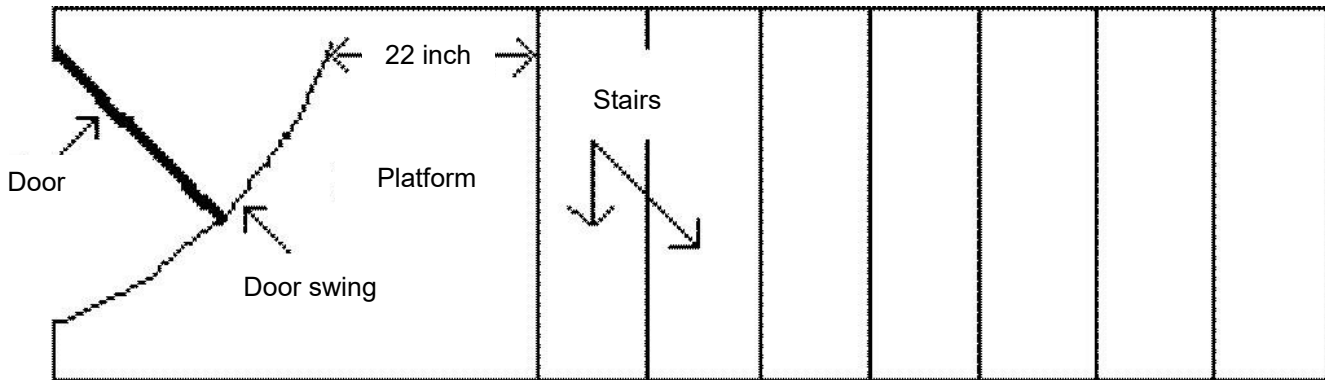

(c) Standard stairs. In addition to paragraph (b) of this section, the employer must ensure standard stairs:

- (1) Are installed at angles between 30 to 50 degrees from the horizontal;
- (2) Have a maximum riser height of 9.5 inches (24 cm);
- (3) Have a minimum tread depth of 9.5 inches (24 cm); and
- (4) Have a minimum width of 22 inches (56 cm) between vertical barriers (see Figure D-8 of this section).

(5) Exception to paragraphs (c)(2) and (3) of this section. The requirements of paragraphs (c)(2) and (3) do not apply to standard stairs installed prior to January 17, 2017. OSHA will deem those stairs in compliance if they meet the dimension requirements specified in Table D-1 of this section or they use a combination that achieves the angle requirements of paragraph (c)(1) of this section.

TABLE D-1 STAIRWAY RISE AND TREAD DIMENSIONS		
Angle To Horizontal	Rise (In Inches)	Tread Run (In Inches)
30 degree 35 minutes	6 1/2	11
32 degree 8 minutes	6 3/4	10 3/4
33 degree 41 minutes	7	10 1/2
35 degree 16 minutes	7 1/4	10 1/4
36 degree 52 minutes	7 1/2	10
38 degree 29 minutes	7 3/4	9 3/4
40 degree 8 minutes	8	9 1/2
41 degree 44 minutes	8 1/4	9 1/4
43 degree 22 minutes	8 1/2	9
45 degree 00 minutes	8 3/4	8 3/4
46 degree 38 minutes	9	8 1/2
48 degree 16 minutes	9 1/4	8 1/4
49 degree 54 minutes	9 1/2	8

Figure D-8

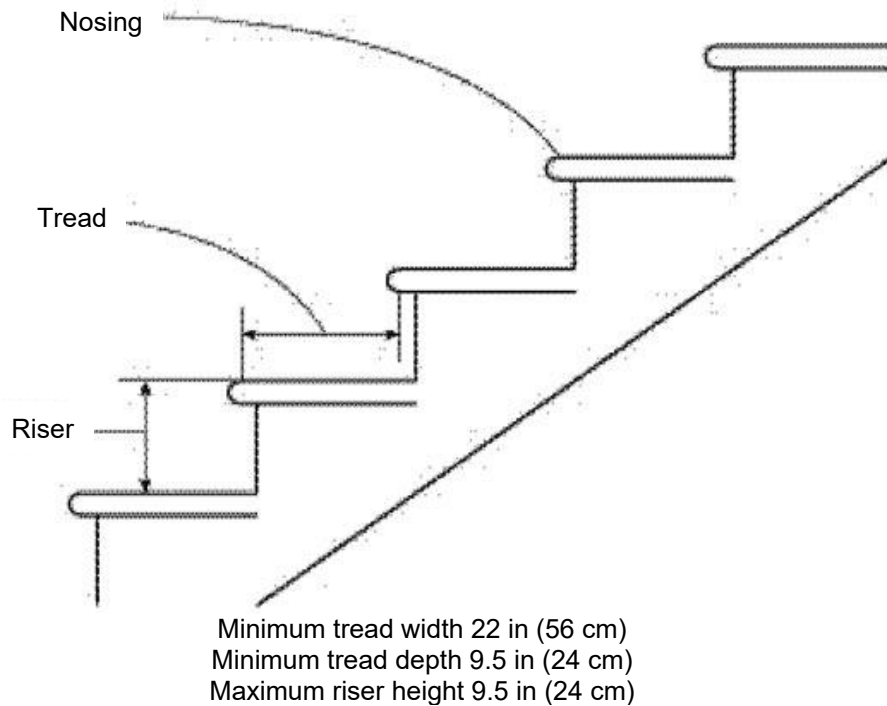

(d) Spiral stairs. In addition to paragraph (b) of this section, the employer must ensure spiral stairs:

- (1) Have a minimum clear width of 26 inches (66 cm);
- (2) Have a maximum riser height of 9.5 inches (24 cm);
- (3) Have a minimum headroom above spiral stair treads of at least 6 feet, 6 inches (2 m), measured from the leading edge of the tread;
- (4) Have a minimum tread depth of 7.5 inches (19 cm), measured at a point 12 inches (30 cm) from the narrower edge;
- (5) Have a uniform tread size;

(e) Ship stairs. In addition to paragraph (b) of this section, the employer must ensure ship stairs (see Figure D-9 of this section):

- (1) Are installed at a slope of 50 to 70 degrees from the horizontal;
- (2) Have open risers with a vertical rise between tread surfaces of 6.5 to 12 inches (17 to 30 cm);
- (3) Have minimum tread depth of 4 inches (10 cm); and
- (4) Have a minimum tread width of 18 inches (46 cm).

(f) Alternating tread-type stairs. In addition to paragraph (b) of this section, the employer must ensure alternating tread-type stairs:

- (1) Have a series of treads installed at a slope of 50 to 70 degrees from the horizontal;
- (2) Have a distance between handrails of 17 to 24 inches (51 to 61 cm);
- (3) Have a minimum tread depth of 8.5 inches (22 cm); and
- (4) Have open risers if the tread depth is less than 9.5 inches (24 cm);
- (5) Have a minimum tread width of 7 inches (18 cm), measured at the leading edge of the tread (i.e., nosing).

Figure D-9 -- Ship Stairs

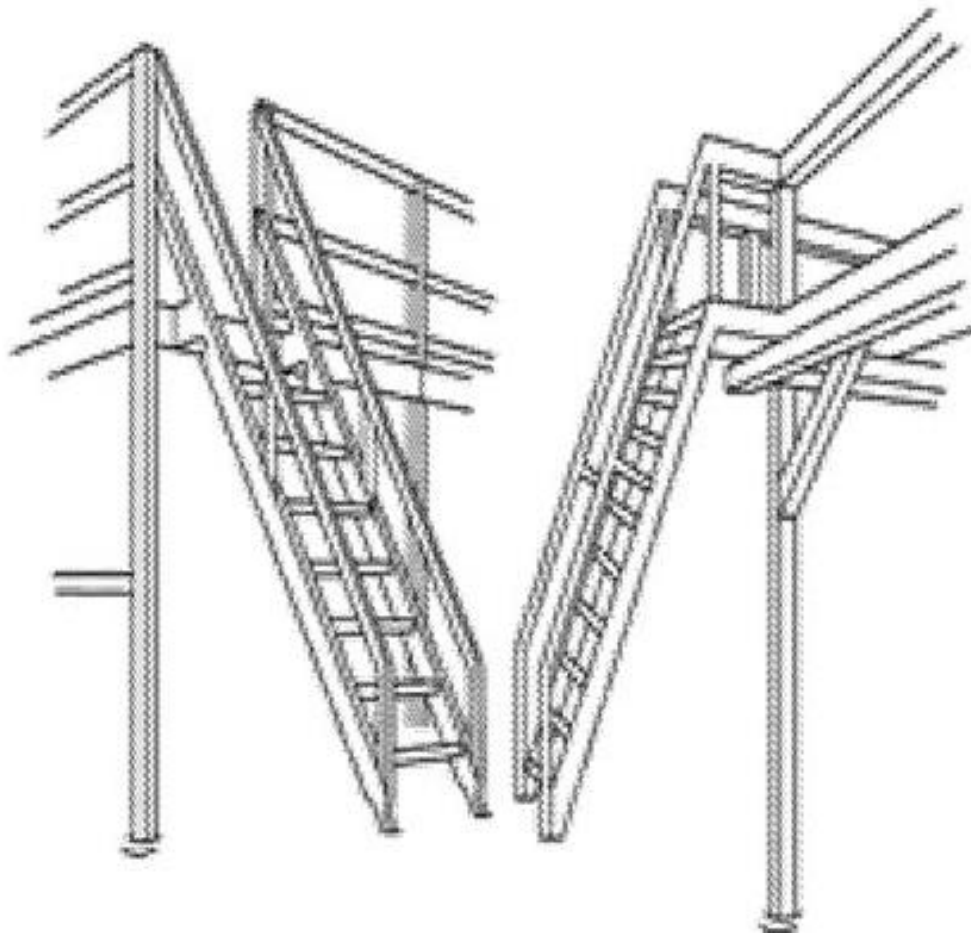
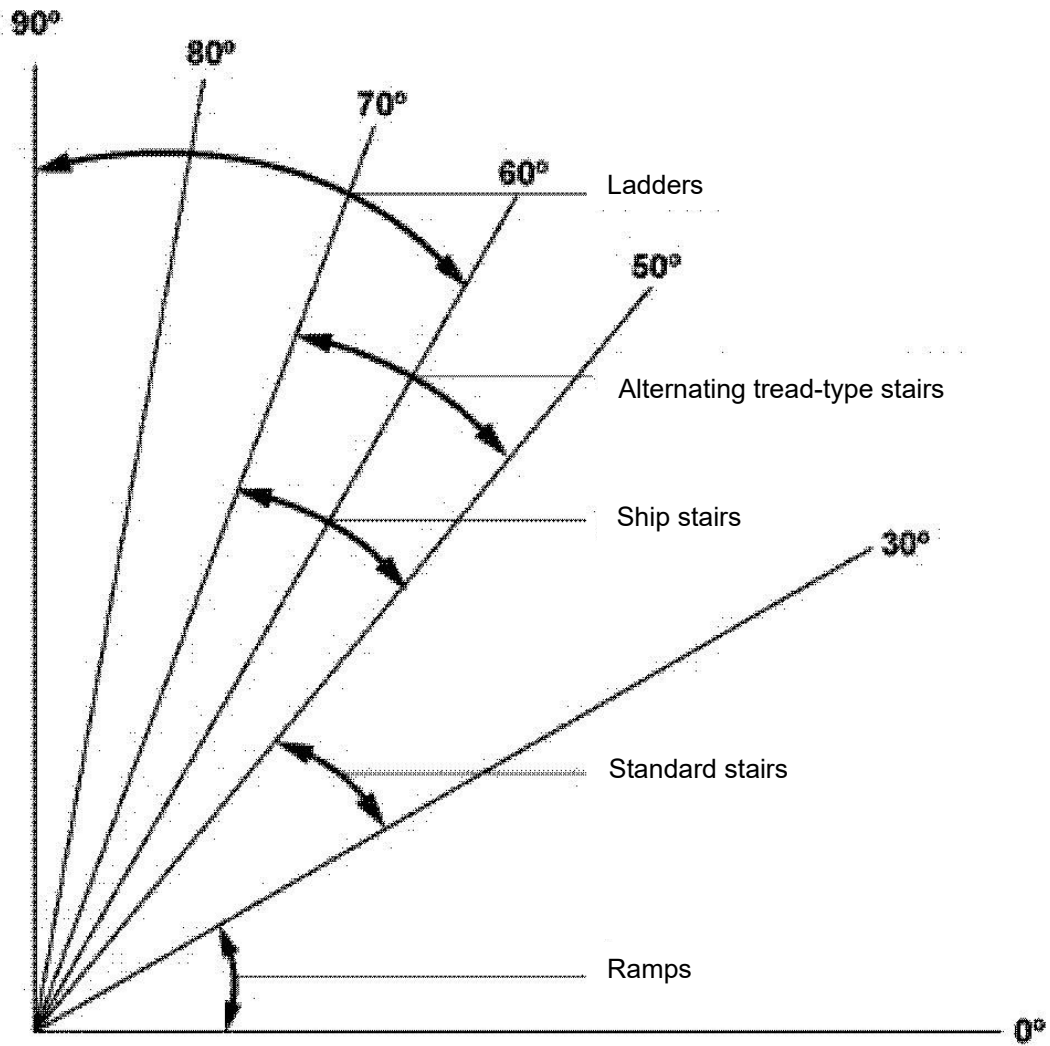

Figure D-10 -- Angles for Stairs, Ramps, and Ladders



ANGLE	TYPE
$\leq 30^\circ$	Ramps
$30^\circ - 50^\circ$	Standard stairs
$50^\circ - 70^\circ$	Ship stairs
$50^\circ - 70^\circ$	Alternating tread-type stairs
$60^\circ - 90^\circ$	Ladders

[39 FR 23502, June 27, 1974, as amended at 43 FR 49744, Oct. 24, 1978; 49 FR 5321, Feb. 10, 1984; 81 FR 82987-82990, Nov. 18, 2016]

1910.26 DOCKBOARDS

The employer must ensure that each dockboard used meets the requirements of this section. The employer must ensure:

(a) Dockboards are capable of supporting the maximum intended load in accordance with § 1910.22(b);

(b)(1) Dockboards put into initial service on or after January 17, 2017 are designed, constructed, and maintained to prevent transfer vehicles from running off the dockboard edge;

(2) Exception to paragraph (b)(1) of this section. When the employer demonstrates there is no hazard of transfer vehicles running off the dockboard edge, the employer may use dockboards that do not have run-off protection.

(c) Portable dockboards are secured by anchoring them in place or using equipment or devices that prevent the dockboard from moving out of a safe position. When the employer demonstrates that securing the dockboard is not feasible, the employer must ensure there is sufficient contact between the dockboard and the surface to prevent the dockboard from moving out of a safe position;

(d) Measures, such as wheel chocks or sand shoes, are used to prevent the transport vehicle (e.g. a truck, semitrailer, trailer, or rail car) on which a dockboard is placed, from moving while employees are on the dockboard; and

(e) Portable dockboards are equipped with handholds or other means to permit safe handling of dockboards.

[39 FR 23502, June 27, 1974, as amended at 43 FR 49745, Oct. 24, 1978; 49 FR 5321, Feb. 10, 1984; 55 FR 32014, Aug. 6, 1990; 81 FR 82990, Nov. 18, 2016]

1910.27 SCAFFOLDS AND ROPE DESCENT SYSTEMS

(a) Scaffolds. Scaffolds used in general industry must meet the requirements in 29 CFR part 1926, subpart L (Scaffolds).

(b) Rope descent systems.

(1) Anchorages.

(i) Before any rope descent system is used, the building owner must inform the employer, in writing that the building owner has identified, tested, certified, and maintained each anchorage so it is capable of supporting at least 5,000 pounds (268 kg), in any direction, for each employee attached. The information must be based on an annual inspection by a qualified person and certification of each anchorage by a qualified person, as necessary, and at least every 10 years.

(ii) The employer must ensure that no employee uses any anchorage before the employer has obtained written information from the building owner that each anchorage meets the requirements of paragraph (b)(1)(i) of this section. The employer must keep the information for the duration of the job.

(iii) The requirements in paragraphs (b)(1)(i) and (ii) of this section must be implemented no later than November 20, 2017.

(2) Use of rope descent systems. The employer must ensure:

(i) No rope descent system is used for heights greater than 300 feet (91 m) above grade unless the employer demonstrates that it is not feasible to access such heights by any other means or that those means pose a greater hazard than using a rope descent system;

(ii) The rope descent system is used in accordance with instructions, warnings, and design limitations set by the manufacturer or under the direction of a qualified person;

(iii) Each employee who uses the rope descent system is trained in accordance with § 1910.30;

(iv) The rope descent system is inspected at the start of each workshift that it is to be used. The employer must ensure damaged or defective equipment is removed from service immediately and replaced;

(v) The rope descent system has proper rigging, including anchorages and tiebacks, with particular emphasis on providing tiebacks when counterweights, cornice hooks, or similar non-permanent anchorages are used;

(vi) Each employee uses a separate, independent personal fall arrest system that meets the requirements of subpart I of this part;

(vii) All components of each rope descent system, except seat boards, are capable of sustaining a minimum rated load of 5,000 pounds (22.2 kN). Seat boards must be capable of supporting a live load of 300 pounds (136 kg);

(viii) Prompt rescue of each employee is provided in the event of a fall;

(ix) The ropes of each rope descent system are effectively padded or otherwise protected, where they can contact edges of the building, anchorage, obstructions, or other surfaces, to prevent them from being cut or weakened;

(x) Stabilization is provided at the specific work location when descents are greater than 130 feet (39.6 m);

(xi) No employee uses a rope descent system when hazardous weather conditions, such as storms or gusty or excessive wind, are present;

(xii) Equipment, such as tools, squeegees, or buckets, is secured by a tool lanyard or similar method to prevent it from falling; and

(xiii) The ropes of each rope descent system are protected from exposure to open flames, hot work, corrosive chemicals, and other destructive conditions.

[81 FR 82990-82991, Nov. 18, 2016]

1910.28 DUTY TO HAVE FALL PROTECTION AND FALLING OBJECT PROTECTION

(a) General.

(1) This section requires employers to provide protection for each employee exposed to fall and falling object hazards. Unless stated otherwise, the employer must ensure that all fall protection and falling object protection required by this section meet the criteria in § 1910.29, except that personal fall protection systems required by this section meet the criteria of § 1910.140.

(2) This section does not apply:

(i) To portable ladders;

(ii) When employers are inspecting, investigating, or assessing workplace conditions or work to be performed prior to the start of work or after all work has been completed. This exemption does not apply when fall protection systems or equipment meeting the requirements of § 1910.29 have been installed and are available for workers to use for pre-work and post-work inspections, investigations, or assessments;

(iii) To fall hazards presented by the exposed perimeters of entertainment stages and the exposed perimeters of rail-station platforms;

(iv) To powered platforms covered by § 1910.66(j);

(v) To aerial lifts covered by § 1910.67(c)(2)(v);

(vi) To telecommunications work covered by § 1910.268(n)(7) and (8); and

(vii) To electric power generation, transmission, and distribution work covered by § 1910.269(g)(2)(i).

(b) Protection from fall hazards.

(1) Unprotected sides and edges.

(i) Except as provided elsewhere in this section, the employer must ensure that each employee on a walking-working surface with an unprotected side or edge that is 4 feet (1.2 m) or more above a lower level is protected from falling by one or more of the following:

(A) Guardrail systems;

(B) Safety net systems; or

(C) Personal fall protection systems, such as personal fall arrest, travel restraint, or positioning systems.

(ii) When the employer can demonstrate that it is not feasible or creates a greater hazard to use guardrail, safety net, or personal fall protection systems on residential roofs, the employer must develop and implement a fall protection plan that meets the requirements of 29 CFR 1926.502(k) and training that meets the requirements of 29 CFR 1926.503(a) and (c).

Note to paragraph (b)(1)(ii) of this section: There is a presumption that it is feasible and will not create a greater hazard to use at least one of the above-listed fall protection systems specified in paragraph (b)(1)(i) of this section. Accordingly, the employer has the burden of establishing that it is not feasible or creates a greater hazard to provide the fall protection systems specified in paragraph (b)(1)(i) and that it is necessary to implement a fall protection plan that complies with § 1926.502(k) in the particular work operation, in lieu of implementing any of those systems.

(iii) When the employer can demonstrate that the use of fall protection systems is not feasible on the working side of a platform used at a loading rack, loading dock, or teeming platform, the work may be done without a fall protection system, provided:

(A) The work operation for which fall protection is infeasible is in process;

(B) Access to the platform is limited to authorized employees; and,

(C) The authorized employees are trained in accordance with § 1910.30.

(2) Hoist areas. The employer must ensure:

(i) Each employee in a hoist area is protected from falling 4 feet (1.2 m) or more to a lower level by:

(A) A guardrail system;

(B) A personal fall arrest system; or

(C) A travel restraint system.

(ii) When any portion of a guardrail system, gate, or chains is removed, and an employee must lean through or over the edge of the access opening to facilitate hoisting, the employee is protected from falling by a personal fall arrest system.

(iii) If grab handles are installed at hoist areas, they meet the requirements of § 1910.29(l).

(3) Holes. The employer must ensure:

(i) Each employee is protected from falling through any hole (including skylights) that is 4 feet (1.2 m) or more above a lower level by one or more of the following:

(A) Covers;

(B) Guardrail systems;

(C) Travel restraint systems; or

(D) Personal fall arrest systems.

(ii) Each employee is protected from tripping into or stepping into or through any hole that is less than 4 feet (1.2 m) above a lower level by covers or guardrail systems.

(iii) Each employee is protected from falling into a stairway floor hole by a fixed guardrail system on all exposed sides, except at the stairway entrance. However, for any stairway used less than once per day where traffic across the stairway floor hole prevents the use of a fixed guardrail system (e.g., holes located in aisle spaces), the employer may protect employees from falling into the hole by using a hinged floor hole cover that meets the criteria in § 1910.29 and a removable guardrail system on all exposed sides, except at the entrance to the stairway.

(iv) Each employee is protected from falling into a ladder-way floor hole or ladder-way platform hole by a guardrail system and toeboards erected on all exposed sides, except at the entrance to the hole, where a self-closing gate or an offset must be used.

(v) Each employee is protected from falling through a hatchway and chute floor hole by:

(A) A hinged floor-hole cover that meets the criteria in § 1910.29 and a fixed guardrail system that leaves only one exposed side. When the hole is not in use, the employer must ensure the cover is closed or a removable guardrail system is provided on the exposed sides;

(B) A removable guardrail system and toeboards on not more than two sides of the hole and a fixed guardrail system on all other exposed sides. The employer must ensure the removable guardrail system is kept in place when the hole is not in use; or

(C) A guardrail system or a travel restraint system when a work operation necessitates passing material through a hatchway or chute floor hole.

(4) Dockboards.

(i) The employer must ensure that each employee on a dockboard is protected from falling 4 feet (1.2 m) or more to a lower level by a guardrail system or handrails.

(ii) A guardrail system or handrails are not required when:

(A) Dockboards are being used solely for materials-handling operations using motorized equipment;

(B) Employees engaged in these operations are not exposed to fall hazards greater than 10 feet (3 m); and

(C) Those employees have been trained in accordance with § 1910.30.

(5) Runways and similar walkways.

(i) The employer must ensure each employee on a runway or similar walkway is protected from falling 4 feet (1.2 m) or more to a lower level by a guardrail system.

(ii) When the employer can demonstrate that it is not feasible to have guardrails on both sides of a runway used exclusively for a special purpose, the employer may omit the guardrail on one side of the runway, provided the employer ensures:

(A) The runway is at least 18 inches (46 cm) wide; and

(B) Each employee is provided with and uses a personal fall arrest system or travel restraint system.

(6) Dangerous equipment. The employer must ensure:

(i) Each employee less than 4 feet (1.2 m) above dangerous equipment is protected from falling into or onto the dangerous equipment by a guardrail system or a travel restraint system, unless the equipment is covered or guarded to eliminate the hazard.

(ii) Each employee 4 feet (1.2 m) or more above dangerous equipment must be protected from falling by:

(A) Guardrail systems;

(B) Safety net systems;

(C) Travel restraint systems; or

(D) Personal fall arrest systems.

(7) Openings. The employer must ensure that each employee on a walking-working surface near an opening, including one with a chute attached, where the inside bottom edge of the opening is less than 39 inches (99 cm) above that walking-working surface and the outside bottom edge of the opening is 4 feet (1.2 m) or more above a lower level is protected from falling by the use of:

(i) Guardrail systems;

(ii) Safety net systems;

(iii) Travel restraint systems; or,

(iv) Personal fall arrest systems.

(8) Repair pits, service pits, and assembly pits less than 10 feet in depth. The use of a fall protection system is not required for a repair pit, service pit, or assembly pit that is less than 10 feet (3 m) deep, provided the employer:

(i) Limits access within 6 feet (1.8 m) of the edge of the pit to authorized employees trained in accordance with § 1910.30;

(ii) Applies floor markings at least 6 feet (1.8 m) from the edge of the pit in colors that contrast with the surrounding area; or places a warning line at least 6 feet (1.8 m) from the edge of the pit as well as stanchions that are capable of resisting, without tipping over, a force of at least 16 pounds (71 N) applied horizontally against the stanchion at a height of 30 inches (76 cm); or places a combination of floor markings and warning lines at least 6 feet (1.8 m) from the edge of the pit. When two or more pits in a common area are not more than 15 feet (4.5 m) apart, the employer may comply by placing contrasting floor markings at least 6 feet (1.8 m) from the pit edge around the entire area of the pits; and

(iii) Posts readily visible caution signs that meet the requirements of § 1910.145 and state "Caution-Open Pit."

(9) Fixed ladders (that extend more than 24 feet (7.3 m) above a lower level).

(i) For fixed ladders that extend more than 24 feet (7.3 m) above a lower level, the employer must ensure:

(A) Existing fixed ladders. Each fixed ladder installed before November 19, 2018 is equipped with a personal fall arrest system, ladder safety system, cage, or well;

(B) New fixed ladders. Each fixed ladder installed on and after November 19, 2018, is equipped with a personal fall arrest system or a ladder safety system;

(C) Replacement. When a fixed ladder, cage, or well, or any portion of a section thereof, is replaced, a personal fall arrest system or ladder safety system is installed in at least that section of the fixed ladder, cage, or well where the replacement is located; and

(D) Final deadline. On and after November 18, 2036, all fixed ladders are equipped with a personal fall arrest system or a ladder safety system.

(ii) When a one-section fixed ladder is equipped with a personal fall protection or a ladder safety system or a fixed ladder is equipped with a personal fall arrest or ladder safety system on more than one section, the employer must ensure:

(A) The personal fall arrest system or ladder safety system provides protection throughout the entire vertical distance of the ladder, including all ladder sections; and

(B) The ladder has rest platforms provided at maximum intervals of 150 feet (45.7 m).

(iii) The employer must ensure ladder sections having a cage or well:

(A) Are offset from adjacent sections; and

(B) Have landing platforms provided at maximum intervals of 50 feet (15.2 m).

(iv) The employer may use a cage or well in combination with a personal fall arrest system or ladder safety system provided that the cage or well does not interfere with the operation of the system.

(10) Outdoor advertising (billboards).

(i) The requirements in paragraph (b)(9) of this section, and other requirements in subparts D and I of this part, apply to fixed ladders used in outdoor advertising activities.

(ii) When an employee engaged in outdoor advertising climbs a fixed ladder before November 19, 2018 that is not equipped with a cage, well, personal fall arrest system, or a ladder safety system the employer must ensure the employee:

(A) Receives training and demonstrates the physical capability to perform the necessary climbs in accordance with § 1910.29(h);

(B) Wears a body harness equipped with an 18-inch (46 cm) rest lanyard;

(C) Keeps both hands free of tools or material when climbing on the ladder; and

(D) Is protected by a fall protection system upon reaching the work position.

(11) Stairways. The employer must ensure:

(i) Each employee exposed to an unprotected side or edge of a stairway landing that is 4 feet (1.2 m) or more above a lower level is protected by a guardrail or stair rail system;

(ii) Each flight of stairs having at least 3 treads and at least 4 risers is equipped with stair rail systems and handrails as follows:

TABLE D-2 STAIRWAY HANDRAIL REQUIREMENTS				
Stair Width	Enclosed	One Open Side	Two Open Sides	With Earth Built Up on Both Sides
Less than 44 inches (1.1 m)	At least one handrail	One stair rail system with handrail on open side	One stair rail system with handrail on each open side	
44 inches (1.1 m) to 88 inches (2.2 m)	One handrail on each enclosed side	One stair rail system with handrail on open side and one handrail on enclosed side	One stair rail system with handrail on each open side	
Greater than 88 inches (2.2 m)	One handrail on each enclosed side and one intermediate handrail located in the middle of the stair	One stair rail system with handrail on open side, one handrail on enclosed side, and one intermediate handrail located in the middle of the stair	One side rail system with handrail on each open side and one intermediate handrail located in the middle of the stair	
Exterior stairs less than 44 inches (1.1 m)				One handrail on at least one side
Note to Table: The width of the stair must be clear of all obstructions except handrails.				

(iii) Each ship stairs and alternating tread type stairs is equipped with handrails on both sides.

(12) Scaffolds and rope descent systems. The employer must ensure:

- (i) Each employee on a scaffold is protected from falling in accordance 29 CFR part 1926, subpart L; and
- (ii) Each employee using a rope descent system 4 feet (1.2 m) or more above a lower level is protected from falling by a personal fall arrest system.

(13) Work on low-slope roofs.

(i) When work is performed less than 6 feet (1.6 m) from the roof edge, the employer must ensure each employee is protected from falling by a guardrail system, safety net system, travel restraint system, or personal fall arrest system.

(ii) When work is performed at least 6 feet (1.6 m) but less than 15 feet (4.6 m) from the roof edge, the employer must ensure each employee is protected from falling by using a guardrail system, safety net system, travel restraint system, or personal fall arrest system. The employer may use a designated area when performing work that is both infrequent and temporary.

(iii) When work is performed 15 feet (4.6 m) or more from the roof edge, the employer must:

(A) Protect each employee from falling by a guardrail system, safety net system, travel restraint system, or personal fall arrest system or a designated area. The employer is not required to provide any fall protection, provided the work is both infrequent and temporary; and

(B) Implement and enforce a work rule prohibiting employees from going within 15 feet (4.6 m) of the roof edge without using fall protection in accordance with paragraphs (b)(13)(i) and (ii) of this section.

(14) Slaughtering facility platforms.

(i) The employer must protect each employee on the unprotected working side of a slaughtering facility platform that is 4 feet (1.2 m) or more above a lower level from falling by using:

- (A) Guardrail systems; or
- (B) Travel restraint systems.

(ii) When the employer can demonstrate the use of a guardrail or travel restraint system is not feasible, the work may be done without those systems provided:

(A) The work operation for which fall protection is infeasible is in process;

(B) Access to the platform is limited to authorized employees; and

(C) The authorized employees are trained in accordance with § 1910.30.

(15) Walking-working surfaces not otherwise addressed. Except as provided elsewhere in this section or by other subparts of this part, the employer must ensure each employee on a walking-working surface 4 feet (1.2 m) or more above a lower level is protected from falling by:

- (i) Guardrail systems;
- (ii) Safety net systems; or
- (iii) Personal fall protection systems, such as personal fall arrest, travel restraint, or positioning systems.

(c) Protection from falling objects. When an employee is exposed to falling objects, the employer must ensure that each employee wears head protection that meets the requirements of subpart I of this part. In addition, the employer must protect employees from falling objects by implementing one or more of the following:

(1) Erecting toeboards, screens, or guardrail systems to prevent objects from falling to a lower level;

(2) Erecting canopy structures and keeping potential falling objects far enough from an edge, hole, or opening to prevent them from falling to a lower level; or

(3) Barricading the area into which objects could fall, prohibiting employees from entering the barricaded area, and keeping objects far enough from an edge or opening to prevent them from falling to a lower level.

[39 FR 23502, June 27, 1974, as amended at 43 FR 49746, Oct. 24, 1978; 49 FR 5321, Feb. 10, 1984; 53 FR 12121, Apr. 12, 1988; 81 FR 82991-82994, Nov. 18, 2016]

1910.29 FALL PROTECTION SYSTEMS AND FALLING OBJECT PROTECTION—CRITERIA AND PRACTICES

(a) General requirements. The employer must:

(1) Ensure each fall protection system and falling object protection, other than personal fall protection systems, that this part requires meets the requirements in this section. The employer must ensure each personal fall protection system meets the requirements in subpart I of this part; and

(2) Provide and install all fall protection systems and falling object protection this subpart requires, and comply with the other requirements in this subpart before any employee begins work that necessitates fall or falling object protection.

(b) Guardrail systems. The employer must ensure guardrail systems meet the following requirements:

(1) The top edge height of top rails, or equivalent guardrail system members, are 42 inches (107 cm), plus or minus 3 inches (8 cm), above the walking-working surface. The top edge height may exceed 45 inches (114 cm), provided the guardrail system meets all other criteria of paragraph (b) of this section (see Figure D-11 of this section).

(2) Mid-rails, screens, mesh, intermediate vertical members, solid panels, or equivalent intermediate members are installed between the walking-working surface and the top edge of the guardrail system as follows when there is not a wall or parapet that is at least 21 inches (53 cm) high:

(i) Mid-rails are installed at a height midway between the top edge of the guardrail system and the walking-working surface;

(ii) Screens and mesh extend from the walking-working surface to the top rail and along the entire opening between top rail supports;

(iii) Intermediate vertical members (such as balusters) are installed no more than 19 inches (48 cm) apart; and

(iv) Other equivalent intermediate members (such as additional mid-rails and architectural panels) are installed so that the openings are not more than 19 inches (48 cm) wide.

(3) Guardrail systems are capable of withstanding, without failure, a force of at least 200 pounds (890 N) applied in a downward or outward direction within 2 inches (5 cm) of the top edge, at any point along the top rail.

(4) When the 200-pound (890-N) test load is applied in a downward direction, the top rail of the guardrail system must not deflect to a height of less than 39 inches (99 cm) above the walking-working surface.

(5) Mid-rails, screens, mesh, intermediate vertical members, solid panels, and other equivalent intermediate members are capable of withstanding, without failure, a force of at least 150 pounds (667 N) applied in any downward or outward direction at any point along the intermediate member.

(6) Guardrail systems are smooth-surfaced to protect employees from injury, such as punctures or lacerations, and to prevent catching or snagging of clothing.

(7) The ends of top rails and mid-rails do not overhang the terminal posts, except where the overhang does not pose a projection hazard for employees.

(8) Steel banding and plastic banding are not used for top rails or mid-rails.

(9) Top rails and mid-rails are at least 0.25-inches (0.6 cm) in diameter or in thickness.

(10) When guardrail systems are used at hoist areas, a removable guardrail section, consisting of a top rail and midrail, are placed across the access opening between guardrail sections when employees are not performing hoisting operations. The employer may use chains or gates instead of a removable guardrail section at hoist areas if the employer demonstrates the chains or gates provide a level of safety equivalent to guardrails.

(11) When guardrail systems are used around holes, they are installed on all unprotected sides or edges of the hole.

(12) For guardrail systems used around holes through which materials may be passed:

(i) When materials are being passed through the hole, not more than two sides of the guardrail system are removed; and

(ii) When materials are not being passed through the hole, the hole must be guarded by a guardrail system along all unprotected sides or edges or closed over with a cover.

(13) When guardrail systems are used around holes that serve as points of access (such as ladderways), the guardrail system opening:

(i) Has a self-closing gate that slides or swings away from the hole, and is equipped with a top rail and midrail or equivalent intermediate member that meets the requirements in paragraph (b) of this section; or

(ii) Is offset to prevent an employee from walking or falling into the hole;

(14) Guardrail systems on ramps and runways are installed along each unprotected side or edge.

(15) Manila or synthetic rope used for top rails or mid-rails are inspected as necessary to ensure that the rope continues to meet the strength requirements in paragraphs (b)(3) and (5) of this section.

Note to paragraph (b) of this section: The criteria and practices requirements for guardrail systems on scaffolds are contained in 29 CFR part 1926, subpart L.

Figure D-11 -- Guard Rail Systems

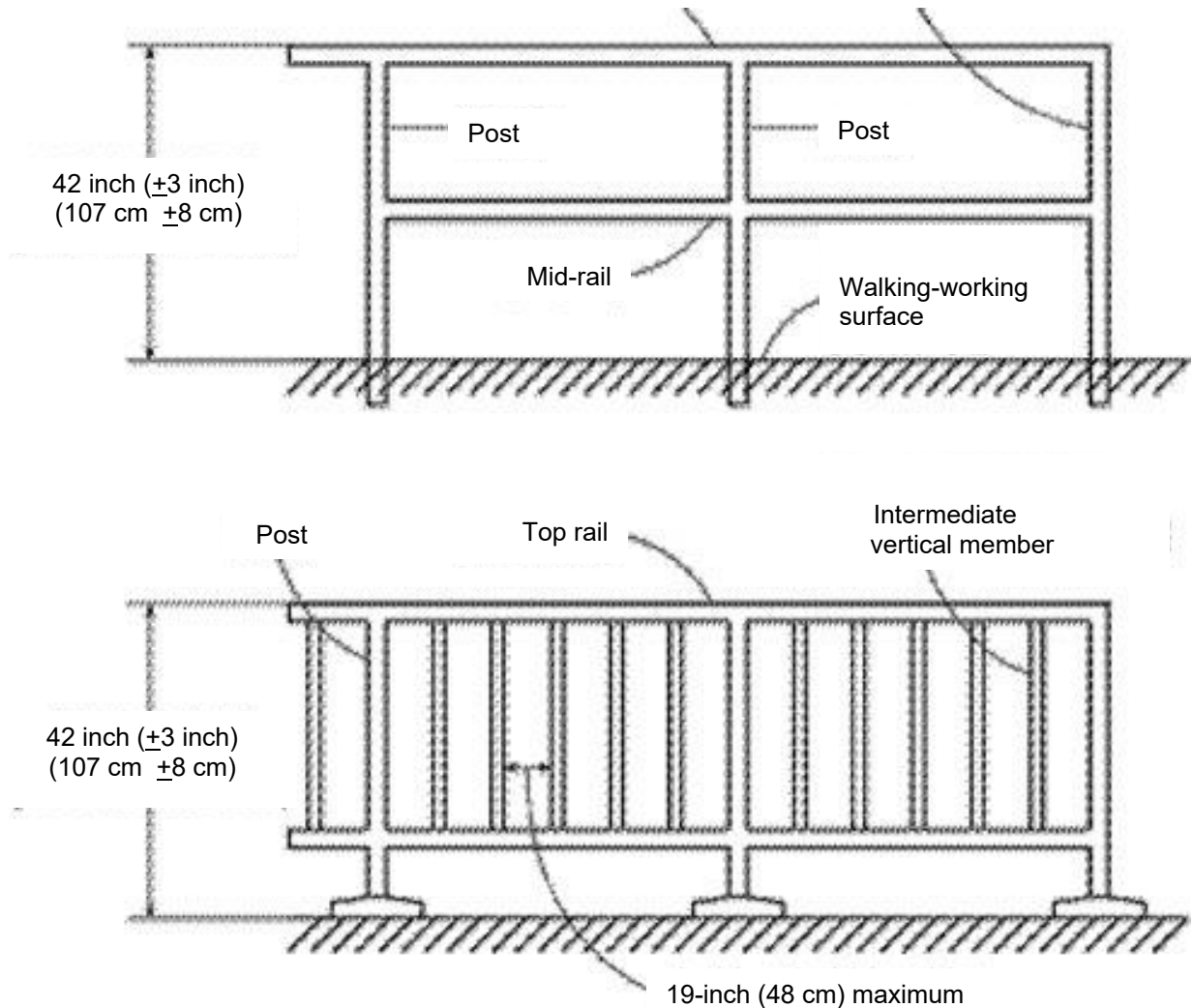

(c) Safety net systems. The employer must ensure each safety net system meets the requirements in 29 CFR part 1926, subpart M.

(d) Designated areas.

(1) When the employer uses a designated area, the employer must ensure:

- (i) Employees remain within the designated area while work operations are underway; and
- (ii) The perimeter of the designated area is delineated with a warning line consisting of a rope, wire, tape, or chain that meets the requirements of paragraphs (d)(2) and (3) of this section.

(2) The employer must ensure each warning line:

- (i) Has a minimum breaking strength of 200 pounds (0.89 kN);
- (ii) Is installed so its lowest point, including sag, is not less than 34 inches (86 cm) and not more than 39 inches (99 cm) above the walking-working surface;
- (iii) Is supported in such a manner that pulling on one section of the line will not result in slack being taken up in adjacent sections causing the line to fall below the limits specified in paragraph (d)(2)(ii) of this section;
- (iv) Is clearly visible from a distance of 25 feet (7.6 m) away, and anywhere within the designated area;

(v) Is erected as close to the work area as the task permits; and

(vi) Is erected not less than 6 feet (1.8 m) from the roof edge for work that is both temporary and infrequent, or not less than 15 feet (4.6 m) for other work.

(3) When mobile mechanical equipment is used to perform work that is both temporary and infrequent in a designated area, the employer must ensure the warning line is erected not less than 6 feet (1.8 m) from the unprotected side or edge that is parallel to the direction in which the mechanical equipment is operated, and not less than 10 feet (3 m) from the unprotected side or edge that is perpendicular to the direction in which the mechanical equipment is operated.

(e) Covers. The employer must ensure each cover for a hole in a walking-working surface:

- (1) Is capable of supporting without failure, at least twice the maximum intended load that may be imposed on the cover at any one time; and
- (2) Is secured to prevent accidental displacement.

(f) Handrails and stair rail systems. The employer must ensure:

(1) Height criteria.

(i) Handrails are not less than 30 inches (76 cm) and not more than 38 inches (97 cm), as measured from the leading edge of the stair tread to the top surface of the handrail (see Figure D-12 of this section).

(ii) The height of stair rail systems meets the following:

(A) The height of stair rail systems installed before January 17, 2017 is not less than 30 inches (76 cm) from the leading edge of the stair tread to the top surface of the top rail; and

(B) The height of stair rail systems installed on or after January 17, 2017 is not less than 42 inches (107 cm) from the leading edge of the stair tread to the top surface of the top rail.

(iii) The top rail of a stair rail system may serve as a handrail only when:

(A) The height of the stair rail system is not less than 36 inches (91 cm) and not more than 38 inches (97 cm) as measured at the leading edge of the stair tread to the top surface of the top rail (see Figure D-13 of this section); and

(B) The top rail of the stair rail system meets the other handrail requirements in paragraph (f) of this section.

(2) Finger clearance. The minimum clearance between handrails and any other object is 2.25 inches (5.7 cm).

(3) Surfaces. Handrails and stair rail systems are smooth-surfaced to protect employees from injury, such as punctures or lacerations, and to prevent catching or snagging of clothing.

(4) Openings in stair rails. No opening in a stair rail system exceeds 19 inches (48 cm) at its least dimension.

(5) Handhold. Handrails have the shape and dimension necessary so that employees can grasp the handrail firmly.

(6) Projection hazards. The ends of handrails and stair rail systems do not present any projection hazards.

(7) Strength criteria. Handrails and the top rails of stair rail systems are capable of withstanding, without failure, a force of at least 200 pounds (890 N) applied in any downward or outward direction within 2 inches (5 cm) of any point along the top edge of the rail.

Figure D-12 -- Handrail Measurement

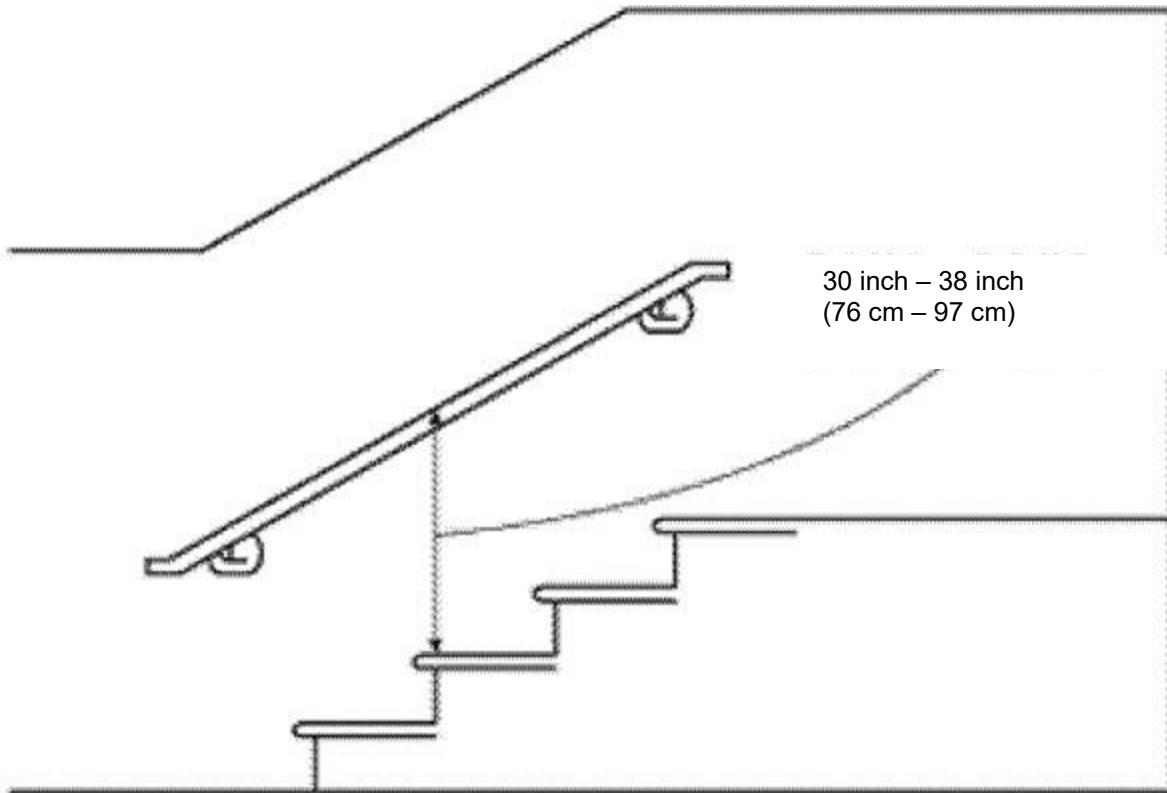
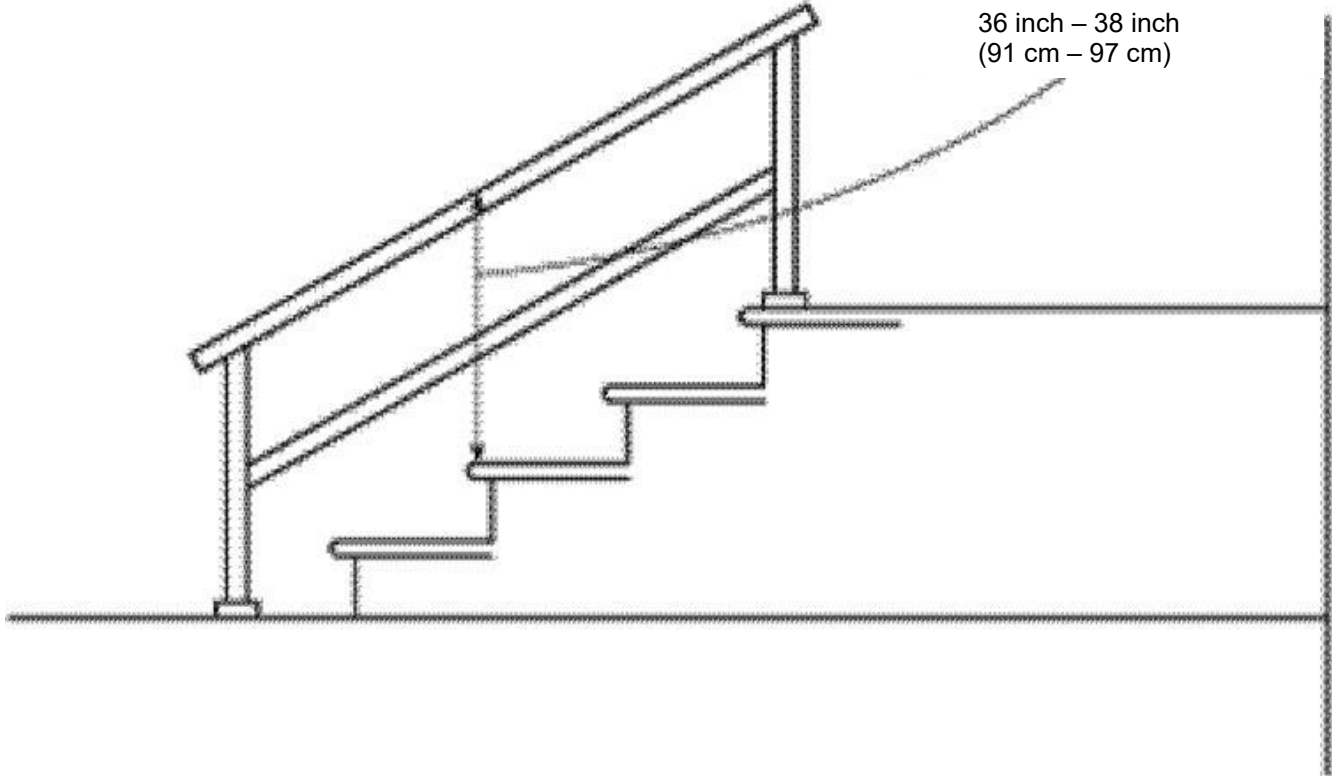

Figure D-13 -- Combination Handrail and Stair Rail



(g) Cages, wells, and platforms used with fixed ladders. The employer must ensure:

(1) Cages and wells installed on fixed ladders are designed, constructed, and maintained to permit easy access to, and egress from, the ladder that they enclose (see Figures D-14 and D-15 of this section);

(2) Cages and wells are continuous throughout the length of the fixed ladder, except for access, egress, and other transfer points;

(3) Cages and wells are designed, constructed, and maintained to contain employees in the event of a fall, and to direct them to a lower landing; and

(4) Platforms used with fixed ladders provide a horizontal surface of at least 24 inches by 30 inches (61 cm by 76 cm).

Note to paragraph (g): Section 1910.28 establishes the requirements that employers must follow on the use of cages and wells as a means of fall protection.

(h) Outdoor advertising. This paragraph (h) applies only to employers engaged in outdoor advertising operations (see § 1910.28(b)(10)). Employers must ensure that each employee who climbs a fixed ladder without fall protection:

(1) Is physically capable, as demonstrated through observations of actual climbing activities or by a physical examination, to perform the duties that may be assigned, including climbing fixed ladders without fall protection;

(2) Has successfully completed a training or apprenticeship program that includes hands-on training on the safe climbing of ladders and is retrained as necessary to maintain the necessary skills;

(3) Has the skill to climb ladders safely, as demonstrated through formal classroom training or on-the-job training, and performance observation; and

(4) Performs climbing duties as a part of routine work activity.

Figure D-14 -- Clearances for Fixed Ladders in Wells

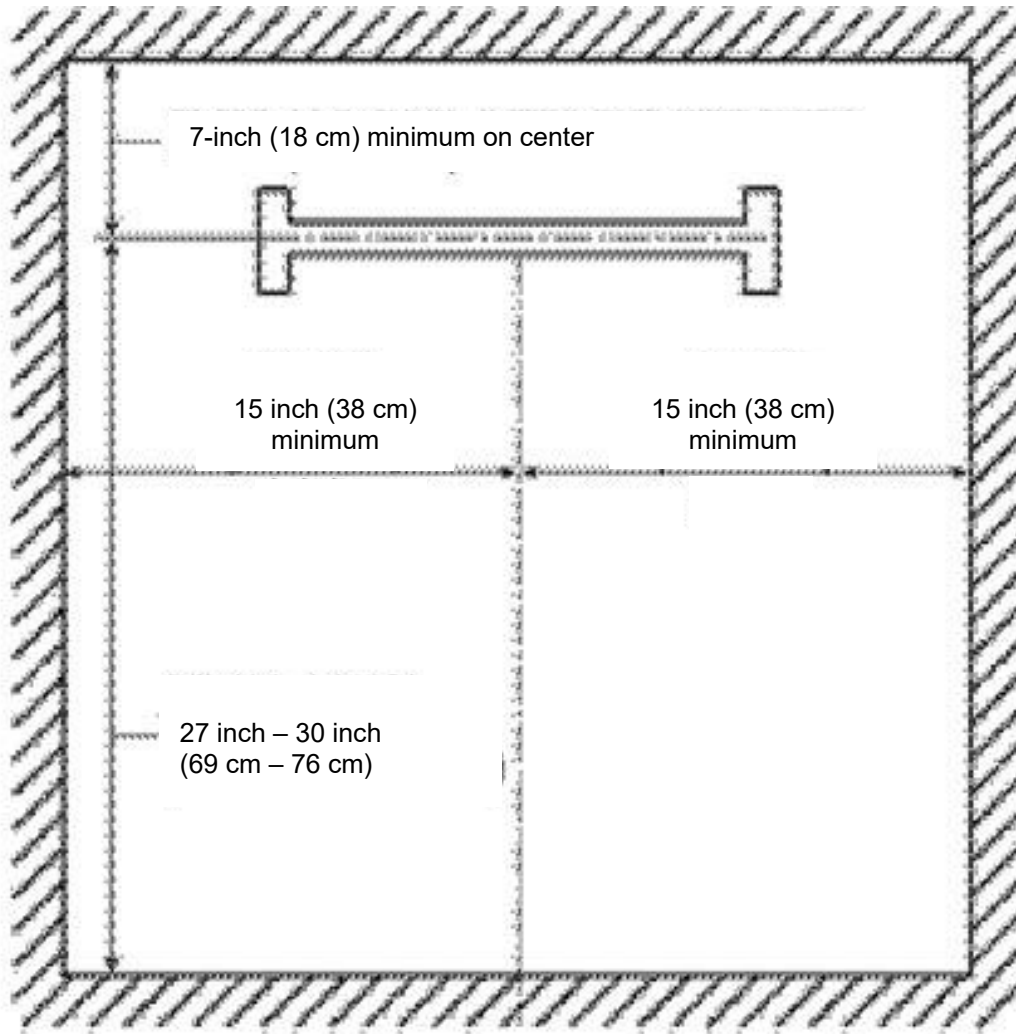
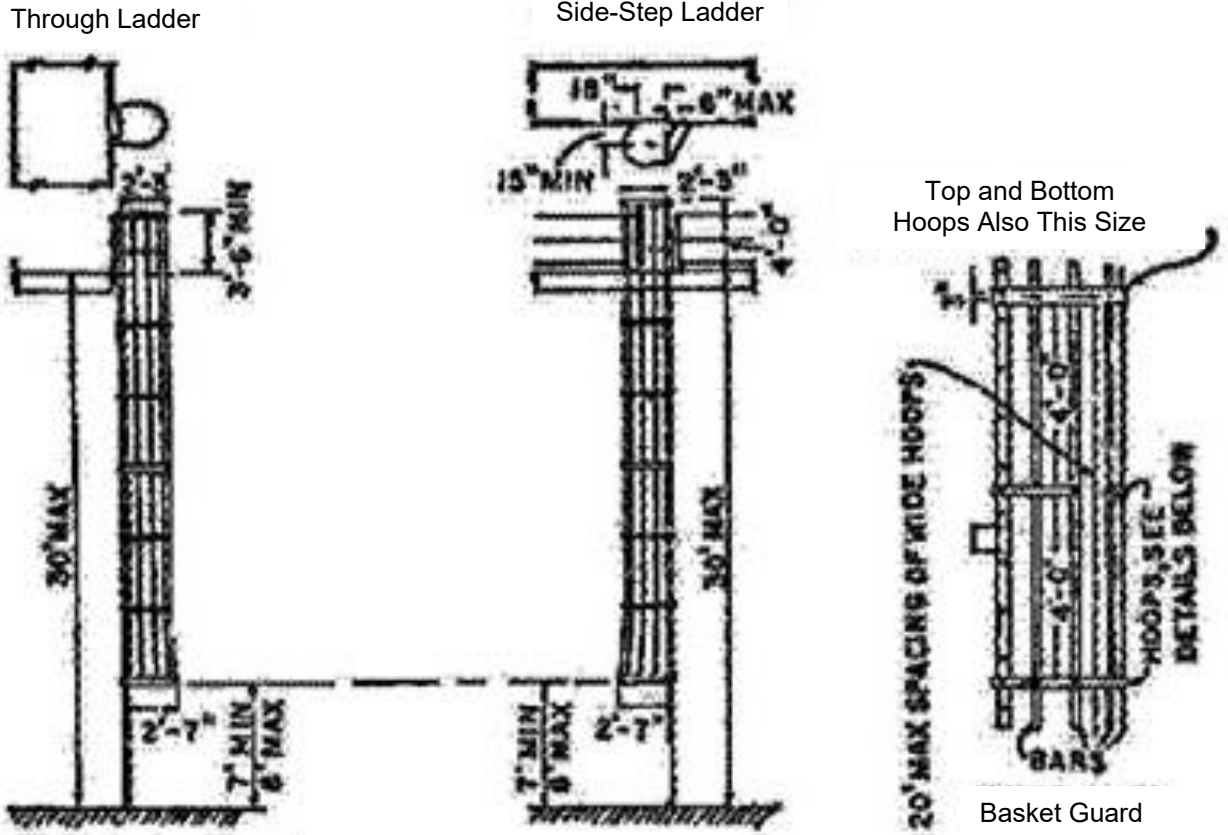
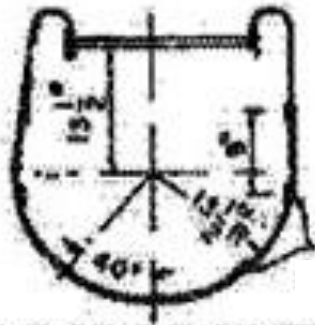

Figure D-15 -- Example of General Construction of Cages



Access to Landing Platform Through Ladder

Access Lateral From Ladder



Basket Guard Hoop Bar Ladder

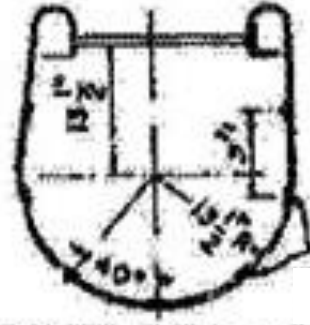

Basket Guard Hoop Angle Iron Ladder

(i) Ladder safety systems. The employer must ensure:

(1) Each ladder safety system allows the employee to climb up and down using both hands and does not require that the employee continuously hold, push, or pull any part of the system while climbing;

(2) The connection between the carrier or lifeline and the point of attachment to the body harness or belt does not exceed 9 inches (23 cm);

(3) Mountings for rigid carriers are attached at each end of the carrier, with intermediate mountings spaced, as necessary, along the entire length of the carrier so the system has the strength to stop employee falls;

(4) Mountings for flexible carriers are attached at each end of the carrier and cable guides for flexible carriers are installed at least 25 feet (7.6 m) apart but not more than 40 feet (12.2 m) apart along the entire length of the carrier;

(5) The design and installation of mountings and cable guides does not reduce the design strength of the ladder; and

(6) Ladder safety systems and their support systems are capable of withstanding, without failure, a drop test consisting of an 18-inch (41-cm) drop of a 500-pound (227-kg) weight.

(j) Personal fall protection systems. Body belts, harnesses, and other components used in personal fall arrest systems, work positioning systems, and travel restraint systems must meet the requirements of § 1910.140.

(k) Protection from falling objects.

(1) The employers must ensure toeboards used for falling object protection:

(i) Are erected along the exposed edge of the overhead walking-working surface for a length that is sufficient to protect employees below.

(ii) Have a minimum vertical height of 3.5 inches (9 cm) as measured from the top edge of the toeboard to the level of the walking-working surface.

(iii) Do not have more than a 0.25-inch (0.5-cm) clearance or opening above the walking-working surface.

(iv) Are solid or do not have any opening that exceeds 1 inch (3 cm) at its greatest dimension.

(v) Have a minimum height of 2.5 inches (6 cm) when used around vehicle repair, service, or assembly pits. Toeboards may be omitted around vehicle repair, service, or assembly pits when the employer can demonstrate that a toeboard would prevent access to a vehicle that is over the pit.

(vi) Are capable of withstanding, without failure, a force of at least 50 pounds (222 N) applied in any downward or outward direction at any point along the toeboard.

(2) The employer must ensure:

(i) Where tools, equipment, or materials are piled higher than the top of the toeboard, paneling or screening is installed from the toeboard to the midrail of the guardrail system and for a length that is sufficient to protect employees below. If the items are piled higher than the midrail, the employer also must install paneling or screening to the top rail and for a length that is sufficient to protect employees below; and

(ii) All openings in guardrail systems are small enough to prevent objects from falling through the opening.

(3) The employer must ensure canopies used for falling object protection are strong enough to prevent collapse and to prevent penetration by falling objects.

(l) Grab handles. The employer must ensure each grab handle:

(1) Is not less than 12 inches (30 cm) long;

(2) Is mounted to provide at least 3 inches (8 cm) of clearance from the framing or opening; and

(3) Is capable of withstanding a maximum horizontal pull-out force equal to two times the maximum intended load or 200 pounds (890 N), whichever is greater.

[81 FR 82994-82998, Nov. 18, 2016]

1910.30 TRAINING REQUIREMENTS

(a) Fall hazards.

(1) Before any employee is exposed to a fall hazard, the employer must provide training for each employee who uses personal fall protection systems or who is required to be trained as specified elsewhere in this subpart. Employers must ensure employees are trained in the requirements of this paragraph on or before May 17, 2017.

(2) The employer must ensure that each employee is trained by a qualified person.

(3) The employer must train each employee in at least the following topics:

(i) The nature of the fall hazards in the work area and how to recognize them;

(ii) The procedures to be followed to minimize those hazards;

(iii) The correct procedures for installing, inspecting, operating, maintaining, and disassembling the personal fall protection systems that the employee uses; and

(iv) The correct use of personal fall protection systems and equipment specified in paragraph (a)(1) of this section, including, but not limited to, proper hook-up, anchoring, and tie-off techniques, and methods of equipment inspection and storage, as specified by the manufacturer.

(b) Equipment hazards.

(1) The employer must train each employee on or before May 17, 2017 in the proper care, inspection, storage, and use of equipment covered by this subpart before an employee uses the equipment.

(2) The employer must train each employee who uses a dockboard to properly place and secure it to prevent unintentional movement.

(3) The employer must train each employee who uses a rope descent system in proper rigging and use of the equipment in accordance with § 1910.27.

(4) The employer must train each employee who uses a designated area in the proper set-up and use of the area.

(c) Retraining. The employer must retrain an employee when the employer has reason to believe the employee does not have the understanding and skill required by paragraphs (a) and (b) of this section. Situations requiring retraining include, but are not limited to, the following:

(1) When changes in the workplace render previous training obsolete or inadequate;

(2) When changes in the types of fall protection systems or equipment to be used render previous training obsolete or inadequate; or

(3) When inadequacies in an affected employee's knowledge or use of fall protection systems or equipment indicate that the employee no longer has the requisite understanding or skill necessary to use equipment or perform the job safely.

(d) Training must be understandable. The employer must provide information and training to each employee in a manner that the employee understands.

[39 FR 23502, June 27, 1974, as amended at 49 FR 5322, Feb. 10, 1984; 61 FR 9227, March 7, 1996; 81 FR 82998, Nov. 18, 2016]



Michigan Occupational Safety and Health Administration
PO Box 30643
Lansing, Michigan 48909-8143
For technical questions of this standard – Ph: 517-284-7750 (GISHD) or 517-284-7720 (CETD)
To order copies of this standard – Ph: 517-284-7740

The Department of Labor and Economic Opportunity will not discriminate against any individual or group because of race, sex, religion, age, national origin, color, marital status, disability, or political beliefs. Auxiliary aids, services and other reasonable accommodations are available upon request to individuals with disabilities.