



DEPARTMENT OF LABOR AND ECONOMIC OPPORTUNITY

GENERAL INDUSTRY STANDARD

Filed with the Secretary of State on October 25, 1972 (as amended February 18, 1997)
(as amended March 14, 2013) (as amended February 16, 2017) **(as amended June 11, 2019)**

These rules take effect immediately upon filing with the secretary of state unless adopted under section 33, 44, or 45a(6) of the administrative procedures act of 1969, 1969 PA 306, MCL 24.233, 24.244, or 24.245a.

Rules adopted under these sections become effective 7 days after filing with the secretary of state.

(By authority conferred on the director of the department of licensing and regulatory affairs by sections 16 and 21 of the Michigan occupational safety and health act, 1974 PA 154, MCL 408.1016 and 408.1021, and Executive Reorganization Order Nos. 1996-2, 2003-1, 2008-4, and 2011-4, MCL 445.2001, 445.2011, 445.2025, and 445.2030)

R 408.11402, R 408.11403, R 408.11421, and R 408.11425 of the Michigan Administrative Code are amended as follows:

PART 14, CONVEYORS

Table of Contents:

GENERAL PROVISIONS	2	ELECTRICAL	4
R 408.11401 Scope.	2	R 408.11432 Starting.	4
R 408.11402 Referenced standards.	2	R 408.11433 Stop devices.	4
R 408.11403 Definitions; A to C.	2	R 408.11435 Grounding.	4
R 408.11404 Definitions; D to I.	2	SPECIFIC CONVEYORS	5
R 408.11405 Definitions; L to N.	2	R 408.11441 Auger and screw conveyors.	5
R 408.11406 Definitions; P.	2	R 408.11442 Belt conveyors.	5
R 408.11407 Definitions; R to V.	3	R 408.11443 Belt trippers.	5
R 408.11411 Employers' and employees' general responsibilities.	3	R 408.11444 Bucket, pivoted bucket and gravity discharge conveyors.	5
R 408.11412 Maintenance.	3	R 408.11445 Carrier and trolley conveyors.	5
DESIGN	3	R 408.11446 Extendable conveyors.	5
R 408.11421 Guarding.	3	R 408.11447 Pneumatic conveyors.	5
R 408.11422 Counterweights.	3	R 408.11448 Portable conveyors.	5
R 408.11423 Take-up.	4	R 408.11449 Reciprocating conveyors.	5
R 408.11424 Hinged sections.	4	R 408.11450 Roller conveyors.	6
R 408.11425 Crossovers.	4	R 408.11451 Slat conveyors.	6
R 408.11426 Passageways and walkways.	4	R 408.11452 Suspended tray or vertical opposed shelf chain conveyors.	6
R 408.11427 Safety factors.	4	R 408.11461 Clothing, jewelry and fire precautions.	6
R 408.11428 Adjustment.	4		
R 408.11429 Rollbacks and runaways.	4		
		APPENDIX - TYPES OF CONVEYORS	7

GENERAL PROVISIONS

R 408.11401 Scope.

Rule 1401. This part applies to the construction, maintenance and operation of conveyors and conveying machinery in, about, or around employment. This part does not apply to industrial trucks, underground mining conveyors, passenger conveyors, stacker cranes, driverless electronic tugs, or construction equipment.

R 408.11402 Referenced standards.

Rule 1402. The following Michigan Occupational Safety and Health Administration (MIOSHA) standards are referenced in these rules. Up to 5 copies of these standards may be obtained at no charge from the Michigan Department of Licensing and Regulatory Affairs, MIOSHA Regulatory Services Section, 530 West Allegan Street, P.O. Box 30643, Lansing, Michigan, 48909-8143 or at the following website: www.michigan.gov/mioshastandards. For quantities greater than 5, the cost, at the time of adoption of these rules, is 4 cents per page.

(a) General Industry Safety and Health Standard Part 2. "Walking-Working Surfaces," R 408.10201 to R 408.10241.

(b) General Industry Safety and Health Standard Part 7. "Guards for Power Transmission," R 408.10701 to R 408.10765.

R 408.11403 Definitions; A to C.

Rule 1403. (1) "Aisle" means a path of travel for vehicles and employees.

(2) "Belt conveyor" means an endless belt operating between a drive and a tail-end, with or without bend terminals, and over idler rolls or slider beds that handles bulk materials, packages, or objects placed directly on the belt. See figure 2.

(3) "Belt tripper" means a device incorporating a system of pulleys that cause a conveyor belt to load or unload material at 1 or more points along the length of a belt conveyor. See figure 3.

(4) "Bucket, gravity discharge or pivoted bucket conveyor" means a series of buckets mounted between 2 endless chains or on a belt which may operate in horizontal, inclined or vertical paths. See figure 4.

(5) "Conveyor" means a horizontal, inclined or vertical device for moving or transporting bulk materials, packages or objects in a predetermined path by design and having points of loading or discharge fixed or selective.

(6) "Crossover" means a stile-like device used to cross over a conveyor or machine.

R 408.11404 Definitions; D to I.

Rule 1404. (1) "Declined conveyor" means a conveyor transporting down a slope.

(2) "Extendable conveyor" means a conveyor which may be lengthened or shortened by power to suit operating needs.

(3) "Hanger" means a bearing, housing or frame which supports a shaft below a point at which the hanger is attached to the conveyor frame, trough or other structure.

(4) "Hinged section" means a section of conveyor equipped with a hinge mechanism for movable service.

(5) "Horizontal reciprocating or walking beam conveyor" means a reciprocating beam or beams that through hinged flights, special fixtures or other means advances material in a horizontal plane. See figure 7.

(6) "Inclined conveyor" means a conveyor transporting up a slope.

(7) "Indexing" means the controlled starting or stopping of a conveyor by distance or time.

R 408.11405 Definitions; L to N.

Rule 1405. (1) "Live roller conveyor" means a series of rollers over which objects are moved by application of power to some or all of the rollers.

(2) "Means of egress" means a continuous path of travel from any point in a building to the open air outside at ground level.

(3) "Monorail or trolley conveyor" means a series of trolleys supported from or within an overhead track and connected by an endless propelling medium, such as a chain, cable or other linkage, with loads usually suspended from the trolley.

(4) "Nip point" means that point where a moving object creates a pinch or shearing action with a fixed or another moving object.

R 408.11406 Definitions; P.

Rule 1406. (1) "Passageway" means a path of travel for foot traffic only.

(2) "Pinch point" means a point at which it is possible to be caught between moving parts of a machine or between moving and stationary parts of a machine, or between the material and any part of a machine.

(3) "Pneumatic conveyor" means a system of tubes or ducts through which objects or bulk materials are conveyed by a pressure or vacuum system. See figure 5.

(4) "Portable conveyor" means a transportable conveyor, usually having supports which provide mobility. See figure 6.

(5) "Pulley" means a wheel, usually cylindrical but sometimes polygonal in cross section, with the wheel's center board for mounting on a shaft and used to transmit power or change direction.

R 408.11407 Definitions; R to V.

Rule 1407 (1) "Rollback" means an uncontrolled run of a conveyor down an inclined slope opposite to the direction of intended travel.

(2) "Roller conveyor" means a series of rollers supported in a frame over which packages or objects are moved manually, by gravity or by power. See figure 8.

(3) "Runaway" means an uncontrolled run of a conveyor on a declined slope in the direction of intended travel.

(4) "Safety factor" means the ratio of the breaking strength of a piece of material or object to the maximum designed load or stress applied when in use.

(5) "Safety limit switch" means a final device used to disconnect power to a conveyor in case of control or operator failure.

(6) "Slat conveyor" means 1 or more endless chains to which non-overlapping, non-interlocking, spaced slats are attached to form a moving support for packages or objects being conveyed. See figure 9.

(7) "Suspended tray conveyor" means pendant trays or carriers attached to 1 or more endless chains which receive and deliver packages or objects at 1 or more locations. See figure 10.

(8) "Vertical reciprocating conveyor" means a conveyor with power or counterbalanced gravity actuated carriers which receive and discharge material to other elevations.

R 408.11411 Employers' and employees' general responsibilities.

Rule 1411. (1) An employer shall provide training to an employee working on or by a conveyor regarding the hazards and safeguards of such work.

(2) An employer shall establish an inspection program to maintain conveyor components in a condition which does not constitute a hazard to the employee.

(3) An employee shall not ride, cross or walk on a conveyor unless it is designed for riding or crossovers are provided as specified in R 408.11425, except a floor-level slat type conveyor moving at not more than 60 feet per minute. A chain or cable conveyor used to tow objects does not require a crossover if the conveyor is not more than 8 inches above the floor, 12 inches in width and painted yellow in color.

R 408.11412 Maintenance.

Rule 1412. (1) Lubrication shall be accomplished by 1 of the following methods:

(a) Scheduling when a conveyor can be shut off and locked out.

(b) Automatic pressure or gravity feed system.

(c) Extension pipe leading to an area outside of guards or away from any hazard.

(2) Lubrication must comply with General Industry Safety Standard Part 7 "Guards for Power Transmission," as referenced in R 408.11402.

(3) Repairs or clean up, where unexpected motion would cause injury, shall be done when power is off and locked out.

(4) A walkway or catwalk along a conveyor shall be maintained clear of spills or other obstructions which may be a slipping or tripping hazard.

(5) A flammable cleaning fluid used in splicing of belts shall be kept in a safety container. Welding, cutting, or smoking shall not be permitted in the area where flammable cleaning fluids are being used.

DESIGN

R 408.11421 Guarding.

Rule 1421. (1) Where a hazard exists, guards must be provided to protect an employee from contact with moving parts where adjustments are required when a conveyor is in operation.

(2) A lift or transfer point must have any nip point guarded and must have a means of complying with power lockout rules.

(3) A conveyor that indexes must be guarded so that an employee will not be caught or trapped by the sudden movement of the conveyor.

(4) A conveyor must be guarded so that an employee will not be caught or trapped between the conveyor and a stationary or moving part.

(5) A trolley conveyor installed overhead and dipping to a work station must have a guard or barrier in compliance with General Industry Safety and Health Standard Part 2. "Walking-Working Surfaces," as referenced in R 408.11402, or the area must be designated as non-pedestrian and telltales must be hung along the portion of the conveyor that dips to protect an employee from accidental injury.

(6) An opening for a conveyor through a floor or wall must be guarded in compliance with General Industry Safety and Health Standard Part 2. "Walking-Working Surfaces," as referenced in R 408.11402.

(7) A conveyor passing over a walkway, passageway, or work area must be provided with a pan or screen-type guard containing sides sufficient to contain any falling material that would cause injury. The designed strength of the guard must be capable of and must continue to withstand the maximum impact load.

R 408.11422 Counterweights.

Rule 1422. (1) A counterweight and its pulleys shall be enclosed pursuant to General Industry Safety Standard Part 7 "Guards for Power Transmission," as referenced in R 408.11402.

(2) A counterweight and its pulleys suspended more than 7 feet above the floor or ground, in an area where an employee could walk, shall have an enclosure around the area of impact or a catch pan under the counterweight of such strength and design to hold the counterweight and pulley from dropping to the ground, floor, or platform.

(3) A counterweight attached to an arm shall have a bolt fastened near the end of the arm or a cable or chain attached to the counterweight to prevent its dropping off the arm.

R 408.11423 Take-up.

Rule 1423. Where a spring take-up is used to maintain tension on a conveyor, the spring and fastening assembly shall be constructed to retain the spring assembly in case of breakage.

R 408.11424 Hinged sections.

Rule 1424. (1) A manually operated hinged section for employee passage through a gravity roller conveyor, chute, belt or other type of conveyor that requires more than a 40-pound lifting effort to operate shall be counterbalanced.

(2) A power operated section for employee passage shall be provided with a mechanical safety device which shall prevent the section from falling in case of power failure.

(3) A power conveyor having a hinged section used for the purpose of clearing a passageway shall be designed so that the section cannot be raised while the conveyor is in operation or the material being conveyed shall be stopped when the section is raised.

R 408.11425 Crossovers.

Rule 1425. (1) A clearance of 80 inches above a floor or platform must be maintained as a means of egress. Where a conveyor reduces this clearance, a crossover, passageway, or different means of egress must be provided.

(2) A crossover must be in compliance with General Industry Safety and Health Standard Part 2. "Walking-Working Surfaces," as referenced in R 408.11402.

(3) A crossover that cannot clear packages or objects on the conveyor must be hinged to swing out of the way or a sensing device must be provided to stop the conveyor if the crossover has not been moved.

R 408.11426 Passageways and walkways.

Rule 1426. (1) A passageway under a conveyor shall have not less than 5 feet of headroom except a main aisle shall have not less than 80 inches of headroom. Where the headroom is less than 80 inches, telltales and illumination of not less than 10 foot candles shall be provided to indicate low headroom.

(2) A maintenance walkway shall be not less than 18 inches wide where it runs along a conveyor.

(3) A walkway along a conveyor in a pit or tunnel shall have illumination of at least 10 foot candles when an employee is required to work in an area.

R 408.11427 Safety factors.

Rule 1427. (1) Structural supports of a conveyor shall be designed and constructed with a minimum design safety factor of at least 3 which shall include static and dynamic loads.

(2) A hook or carrier used on a monorail and a trolley conveyor to carry objects shall be designed with a minimum safety factor of 5 and maintained to hold the object or carriers without creating a hazard.

R 408.11428 Adjustment.

Rule 1428. A conveyor capable of adjustment to variable fixed elevations shall be equipped with a locking device to hold the conveyor at any altitude where failure to hold would create a hazard to an employee.

R 408.11429 Rollbacks and runaways.

Rule 1429. Rollbacks and runaways on a conveyor shall be controlled by 1 or more of the following:

- (a) Track design.
- (b) Back stops.
- (c) Ratchets or one-way clutch on drive pulleys.
- (d) Anti-runaway devices.
- (e) Automatically applied brakes.

ELECTRICAL

R 408.11432 Starting.

Rule 1432. (1) A starting button, except a control button in a console for a manually programmed multi-conveyor system, shall be equipped with a device to prevent accidental actuation.

(2) A powered conveyor, which would cause injury when started, shall not be started until employees in the area are alerted by a signal or by a person in authority that the conveyor is about to start.

(3) Power to a conveyor shall be wired so that after an interruption of electrical service, the conveyor shall not automatically restart upon resumption of electrical service.

R 408.11433 Stop devices.

Rule 1433. (1) An emergency stop device shall be available at each point of operation where a hazard exists and within reach of an employee at that point.

(2) An emergency stop device of the momentary-contact type shall have a means of being maintained by a device in the "off" position.

(3) If more than 1 stop device is located along a conveyor, the devices shall be wired so that the conveyor can be made re-startable only at the location where stopped.

(4) A stop device, except a pull cord, shall be distinguished by its red color.

(5) Conveyors in a series shall be electrically interlocked so that when any conveyor in the series is stopped for any reason, the initial stopping shall cause the upstream conveyors to stop if continued operation creates a hazard.

R 408.11435 Grounding.

Rule 1435. Where an explosion hazard exists, such as, but not limited to, dust or fumes, a means of draining the potential static electricity build up shall be provided and used.

SPECIFIC CONVEYORS

R 408.11441 Auger and screw conveyors.

Rule 1441. An auger or screw conveyor, with an opening not screened or covered and secured by bolts or clamps, shall be equipped with an interlocked cover which shall cut the power when raised and not start until the cover is replaced and the starter actuated.

R 408.11442 Belt conveyors.

Rule 1442. (1) A belt conveyor using a belt tripper or other moving deflector which requires an operator to travel on the belt tripper shall have the operator's platform designed to safeguard the operator from falling or coming in contact with moving or stationary parts.

(2) A nip point at a pulley shall be guarded by an enclosure or barrier constructed to prevent access by an employee's body members or loose clothing.

(3) A belt conveyor for bulk material shall have built up sides where material spilling over the sides is a hazard.

(4) A pulley with rotating shaft shall have projecting shaft ends covered or cut flush with the hanger.

(5) A shuttle or movable hopper mounted on wheels shall have sweeps fastened ahead of the wheels with an opening of not less than 3/8 inch between the sweep and the rail.

R 408.11443 Belt trippers.

Rule 1443. A belt tripper, with or without an operator, shall be equipped with a safety limit switch and a fixed stop to prevent overrun at each end of the runway which shall shut off the power if the tripper moves too close to the end of the runway.

R 408.11444 Bucket, pivoted bucket and gravity discharge conveyors.

Rule 1444. A bucket, pivoted bucket, or gravity-discharge conveyor shall be enclosed with a guard or barrier to protect operating personnel.

R 408.11445 Carrier and trolley conveyors.

Rule 1445. A manually powered carrier or trolley conveyor shall have a protective device on the carrier or rail to prevent the carrier from dropping off the rail or off the end of the rail.

R 408.11446 Extendable conveyors.

Rule 1446. An extendable conveyor shall be equipped with a device located on the outermost end which shall stop movement of the conveyor when contact is made by the device.

R 408.11447 Pneumatic conveyors.

Rule 1447. (1) A pneumatic conveyor shall be designed so that doors to pressure vessels cannot be opened when there is a positive internal pressure.

(2) A gasket holding line pressures shall be shielded to prevent a gasket leak from projecting the conveyed material into a work area if the material would cause a hazard.

(3) A receiver or storage bin shall be equipped with full bin indicators or controls to prevent overfilling, if overfilling will create a hazard.

(4) A pneumatic conveyor carrying oxidizable materials shall be designed for hazards, such as but not limited to explosion, fire or corrosion.

(5) A pneumatic conveyor serving an area containing contaminated air shall be designed so that the contaminated air cannot be transported to another area.

R 408.11448 Portable conveyors.

Rule 1448. The stability of a portable conveyor shall be provided by 1 or more of the following:

(a) Securing to a fixed object.

(b) Use of outriggers.

(c) A base width of not less than 1/3 the height.

(d) A base as wide as the distance from the floor to the center of gravity.

R 408.11449 Reciprocating conveyors.

Rule 1449. (1) A reciprocating conveyor shall have inside and outside nip points guarded.

(2) If the reciprocating member of a horizontal reciprocating conveyor moves within 18 inches of a wall or other object, a barrier shall be installed at the end to prevent access by an employee.

(3) A vertical reciprocating conveyor which is manually loaded or unloaded shall be guarded with an interlock door or gate to prevent an employee being caught within a nip point.

(4) The carriage and controls of a vertical reciprocating conveyor shall be designed and installed to prevent use of the conveyor as a man lift.

R 408.11450 Roller conveyors.

Rule 1450. (1) A roller conveyor with a hinged section or with an open discharge end shall be equipped with a stop device projecting above the rollers which shall prevent a package or object from being discharged off the conveyor unless it is so designed to discharge.

(2) Nip points between power and idler rolls or delivery conveyors and idler rolls shall be eliminated by 1 of the following:

(a) The idler roller set in a 45 degree inclined slot in the direction of travel.

(b) Steel plates welded between the rolls with a maximum of 1/8 inch between plate and rolls.

(c) The idler roller set in a horizontal slot and connected with an interlock switch which will stop the conveyor.

(d) A device which offers equal or better protection may be substituted for subdivision (a), (b), or (c) of this subrule.

(3) The nip point between a belt and a carrier roller on a belt drive live roller conveyor shall be protected by pop-out type carrier rollers or steel plates as prescribed in subrule (2)(a) and (b) of this subrule. The belt conveyor shall be guarded as specified in R 408.11442.

R 408.11451 Slat conveyors.

Rule 1451. (1) A slat conveyor with the slats spaced 1 inch or more apart and moving at floor level or in work areas shall have a solid smooth bed under the slats to prevent a shear hazard.

(2) A slat conveyor with slats more than 1/4 inch, but less than 1 inch apart, and moving at floor level or in a work area shall not have any nip point less than 4 inches below the slats.

R 408.11452 Suspended tray or vertical opposed shelf chain conveyors.

Rule 1452. A suspended tray or vertical opposed shelf chain conveyor which is manually loaded or unloaded shall have safety devices, such as but not limited to lintel and sill switches or deflectors, to safeguard an employee.

R 408.11461 Clothing, jewelry and fire precautions.

Rule 1461. (1) Loose clothing and jewelry, including, but not limited to, long or floppy sleeves or pants with large pantlegs or cuffs, rings, wrist watches, bracelets, ties, and scarves shall not be worn around conveyors where they constitute a hazard to an employee.

(2) Where combustibles, such as, but not limited to, coal or grain, are conveyed or stored, and where a fire caused by slippage between a drive pulley and a belt would create a hazard, the conveyor shall be equipped with a device so adjusted that a 5% loss of full load rated speed of the belt shall shut down the belt drive

APPENDIX
TYPES OF CONVEYORS

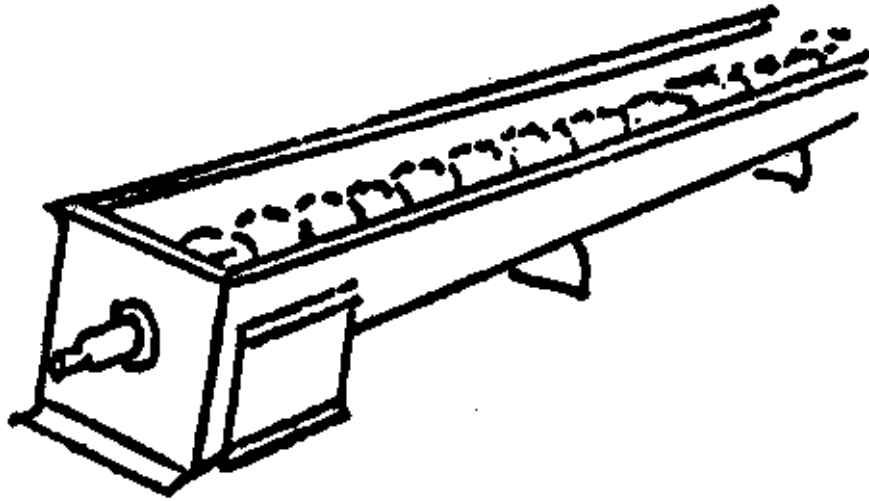

Figure 1 – Auger or Screw Conveyor

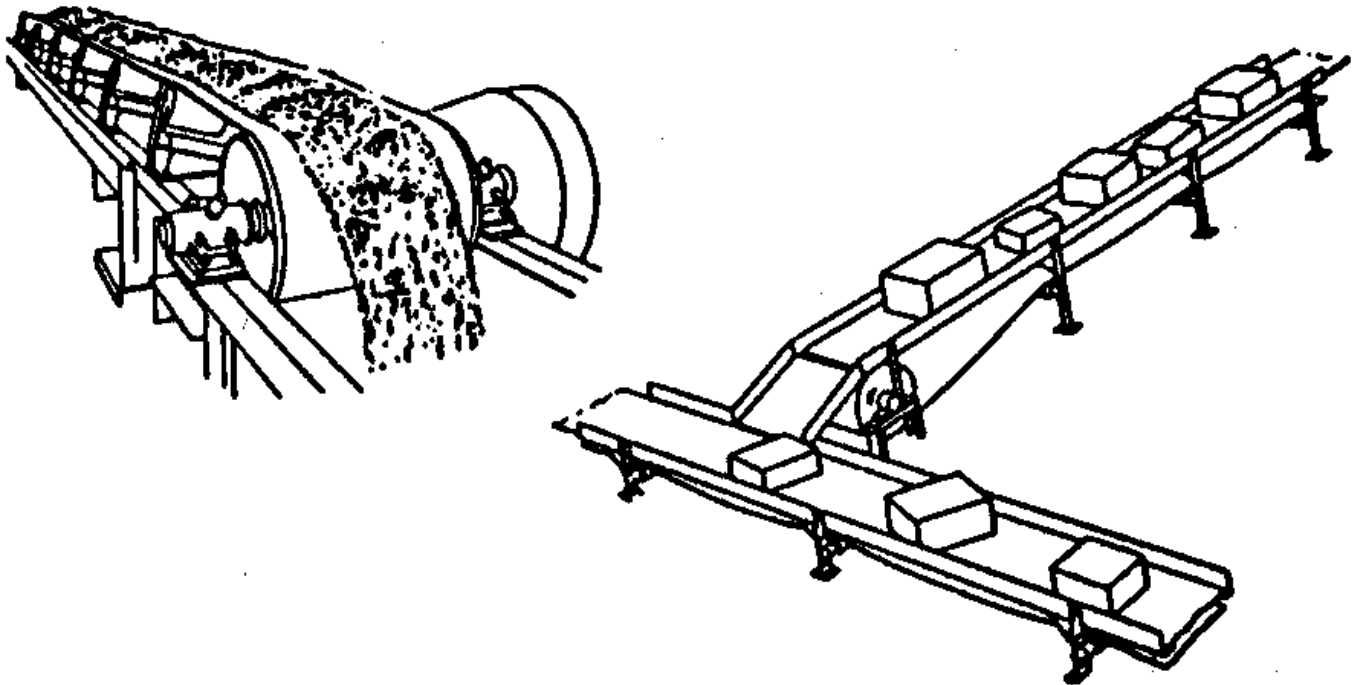

Figure 2 – Belt Conveyors

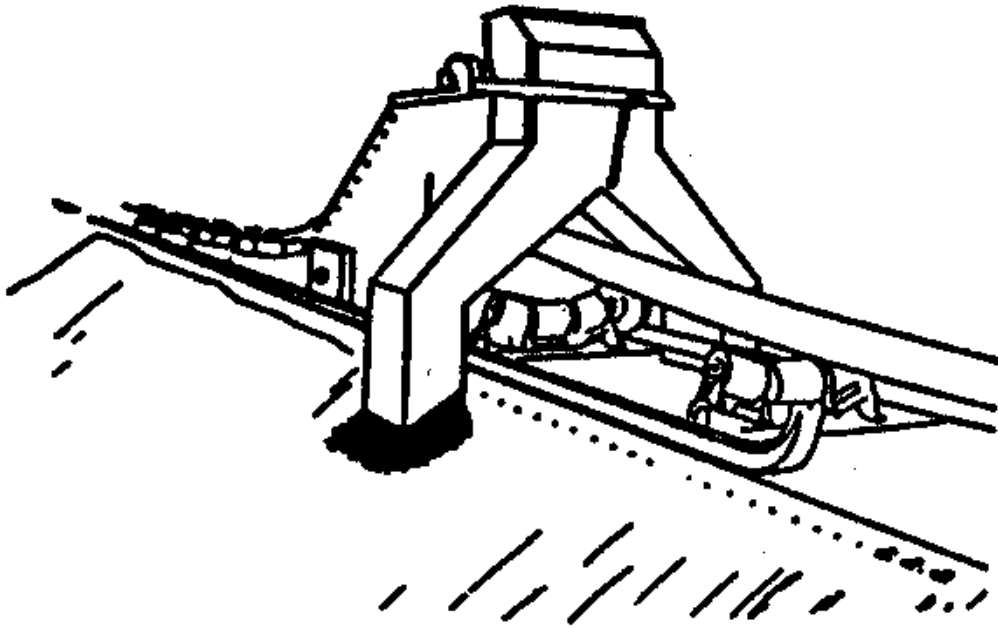

Figure 3 – Belt Tripper

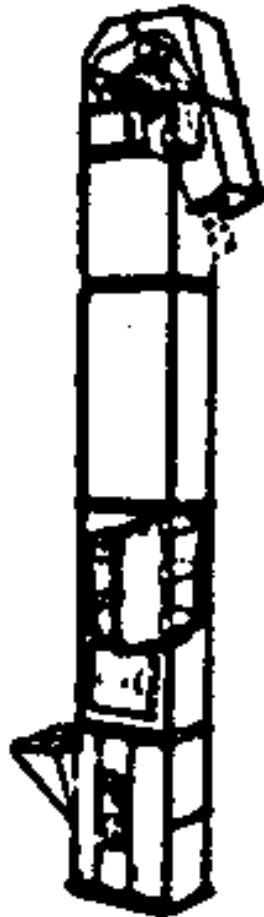

Figure 4 – Bucket, Gravity Discharge or Pivoted Bucket Conveyor

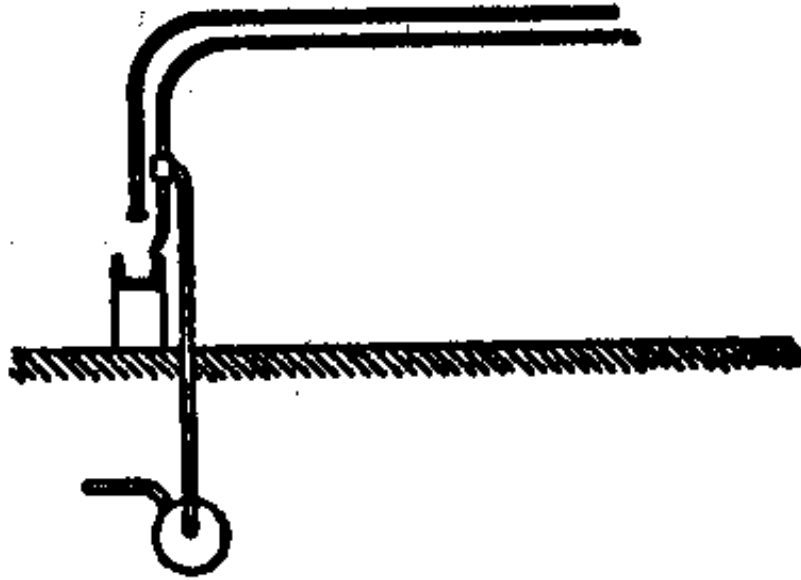

Figure 5 – Pneumatic Conveyor

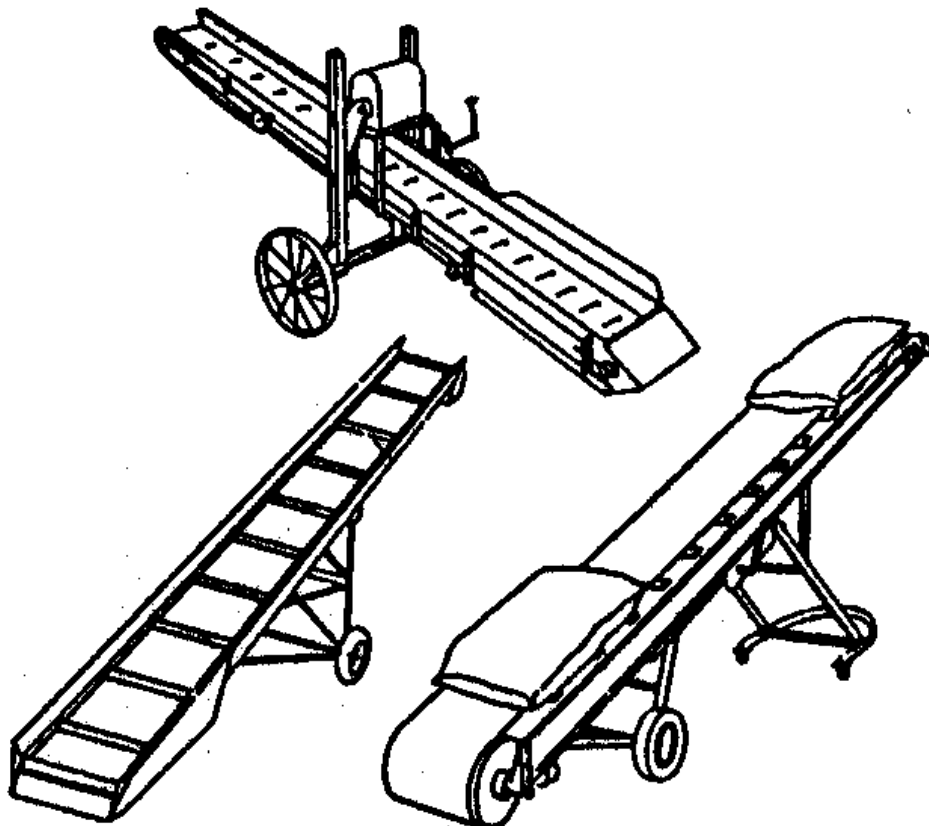

Figure 6 – Portable Conveyors

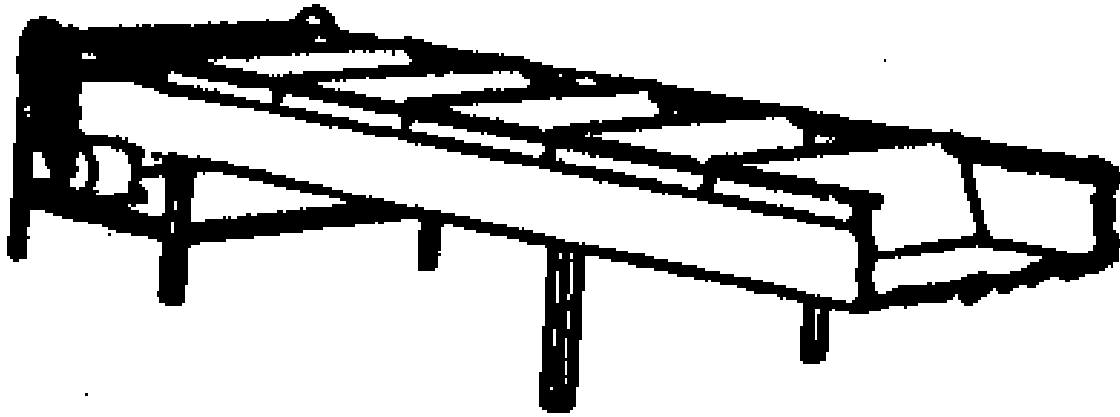

Figure 7 – Reciprocating Conveyor

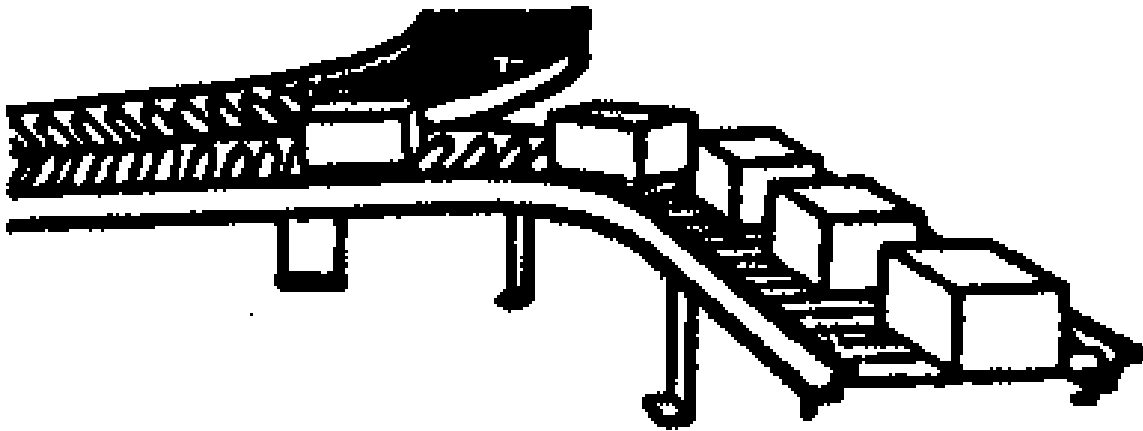

Figure 8 – Roller Conveyor

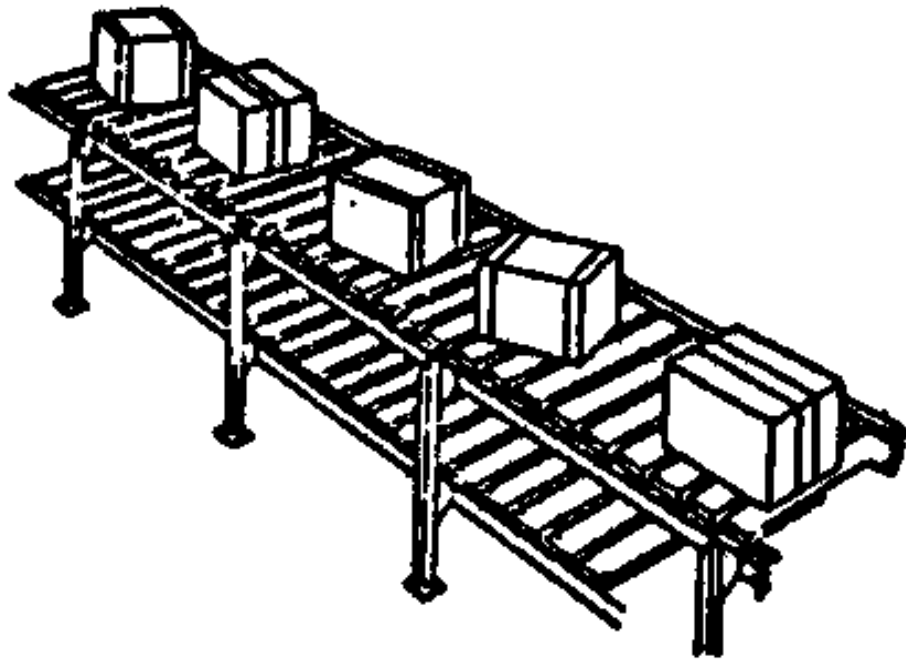

Figure 9 – Slat Conveyor

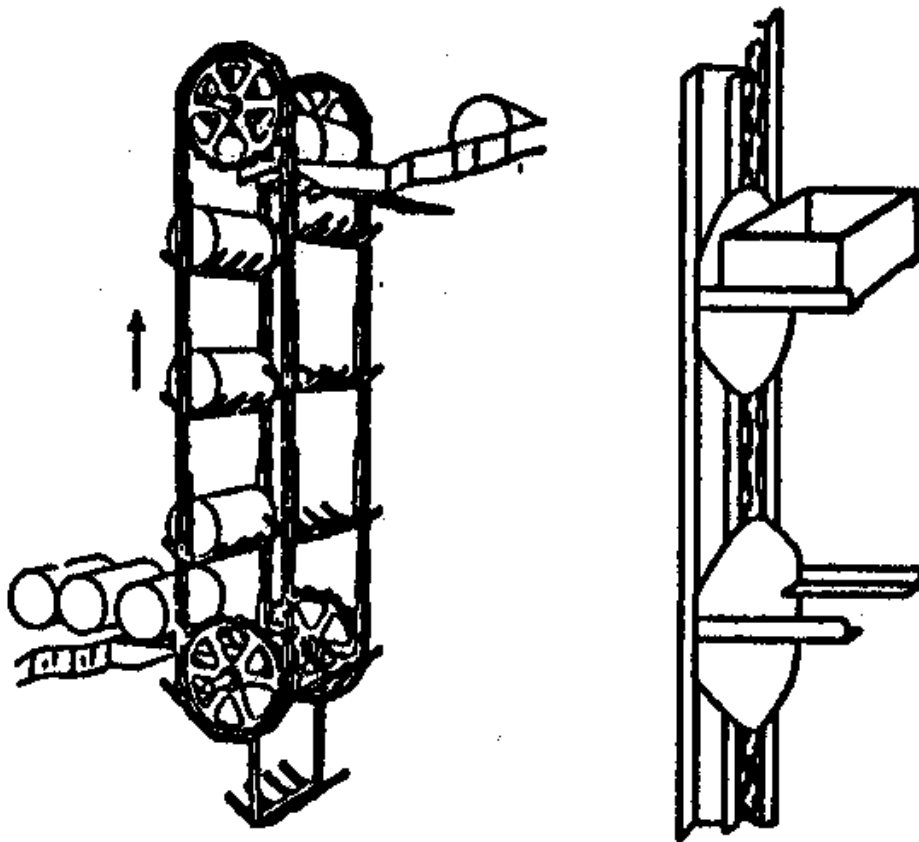

Figure 10 – Suspended Tray Conveyors



Michigan Occupational Safety and Health Administration
PO Box 30643
Lansing, Michigan 48909-8143

For technical questions of this standard – Ph: 517-284-7750 (GISHD) or 517-284-7720 (CETD)
To order copies of this standard – Ph: 517-284-7740

The Department of Labor and Economic Opportunity will not discriminate against any individual or group because of race, sex, religion, age, national origin, color, marital status, disability, or political beliefs. Auxiliary aids, services and other reasonable accommodations are available upon request to individuals with disabilities.