



**DEPARTMENT OF LABOR AND ECONOMIC OPPORTUNITY**

**GENERAL INDUSTRY STANDARD**

Filed with the Secretary of State on November 1, 1971 (as amended July 5, 1974) (as amended August 31, 1976)  
(as amended April 2, 1979) (as amended December 8, 1980) (as amended May 17, 1983)  
(as amended February 18, 1997) (as amended April 5, 2013) **(as amended February 13, 2018)**

These rules become effective immediately upon filing with the Secretary of State  
unless adopted under section 33, 44, or 45a(6) of 1969 PA 306.

Rules adopted under those sections become effective 7 days after filing with the Secretary of State.

(By authority conferred on the director of the department of licensing and regulatory affairs  
by sections 16 and 21 of 1974 PA 154, MCL 408.1016 and 408.1021,  
and Executive Reorganization Order Nos. 1996-2, 2003-1, 2008-4, and 2011-4,  
MCL 445.2001, 445.2011, 445.2025, and 445.2030)

R 408.12701, R 408.12702, R 408.12711, R 408.12712, R 408.12714, R 408.12717, R 408.12718, R 408.12719,  
R 408.12724, R 408.12726, R 408.12727, R 408.12728, R 408.12730, R 408.12733, R 408.12736, R 408.12739,  
R 408.12741, R 408.12755, R 408.12759, R 408.12761, R 408.12767, R 408.12773, R 408.12781, R 408.12784,  
R 408.12791, R 408.12792, R 408.12793, and R 408.12798 of the Michigan Administrative Code are amended,  
as follows:

**PART 27, WOODWORKING MACHINERY**

Table of Contents:

<b>GENERAL PROVISIONS</b> .....	2	R 408.12727 Self-fed circular saw hoods. ....	5
R 408.12701 Scope. ....	2	R 408.12728 Swing and sliding cut-off saws. ....	5
R 408.12702 Referenced MIOSHA standards.....	2	R 408.12729 Inverted swing cut-off, jump saws, underslung saws. ....	7
R 408.12705 Definitions A to C. ....	2	R 408.12730 Radial saws. ....	8
R 408.12706 Definitions D to J. ....	2	R 408.12731 Portable circular saws.....	10
R 408.12707 Definitions M to P. ....	2	R 408.12732 Band saws. ....	10
R 408.12708 Definitions R to T.....	3	R 408.12733 Band re-saw; feed rolls. ....	10
R 408.12709 Definitions V, W.....	3	<b>JOINTERS AND PLANERS</b> .....	10
<b>PLANT LAYOUT</b> .....	3	R 408.12736 Jointers and planers; general. ....	10
R 408.12711 Plant layout; machinery.....	3	R 408.12737 Jointers; guards. ....	10
R 408.12712 Plant layout; floors and aisles. ....	3	R 408.12739 Tenoning machines and automatic edge banders. ....	10
<b>MACHINES AND EQUIPMENT</b> .....	3	R 408.12740 Double and tenoner drives. ....	11
R 408.12714 Machines and equipment; construction. 3		R 408.12741 Hold downs. ....	11
R 408.12716 Machines and equipment; controls. ....	3	R 408.12742 Hand fed tenoners. ....	11
R 408.12717 Machines and equipment; self feed. ....	3	R 408.12744 Boring and mortising machines. ....	11
<b>SAWS</b> .....	4	R 408.12751 Wood shapers.....	12
R 408.12718 Saws generally. ....	4	R 408.12752 Double spindle shapers. ....	12
R 408.12719 Saws; speeds. ....	4	R 408.12755 Planing, molding, sticking, and matching machines. ....	12
R 408.12720 Cracked blades. ....	4	R 408.12756 Feed rolls. ....	12
R 408.12721 Saws; circular. ....	4	R 408.12759 Lathes. ....	12
R 408.12722 Circular saw guards. ....	4		
R 408.12723 Circular saw spreaders. ....	4		
R 408.12724 Non-kickback fingers or dogs.....	4		
R 408.12725 Multiple arbor saw guards.....	4		
R 408.12726 Circular re-saw guards. ....	4		

<b>SANDING MACHINES</b> .....	12
R 408.12761 Sanding machines.....	12
R 408.12762 Drum sanding machines.....	12
R 408.12763 Disk sanding machines.....	12
R 408.12764 Belt sanding machines.....	13
<b>WOODWORKING MACHINES</b> .....	13
R 408.12767 Combination or universal woodworking machines.....	13
R 408.12768 Routers.....	13
R 408.12769 Roll type glue spreaders.....	13
R 408.12770 Other machines not excluded.....	13
R 408.12773 Veneer steaming and soaking vats.....	13
R 408.12774 Vat loading and unloading.....	13
R 408.12776 Ventilation.....	13
R 408.12781 Drag saws.....	13

<b>VENEER MACHINES</b> .....	13
R 408.12784 Veneer cutters.....	13
R 408.12785 Veneer clippers.....	14
R 408.12786 Veneer splicer.....	14
R 408.12787 Veneer jointers.....	14
<b>OPERATING RULES</b> .....	14
R 408.12791 Operating rules; inspection and maintenance.....	14
R 408.12792 Operating rules; selection of machines.....	14
R 408.12793 Operating rules; saw.....	14
R 408.12795 Operating rules; jointers.....	15
R 408.12796 Operating rules; lathes.....	15
R 408.12797 Guard substitutes.....	15
R 408.12798 Clothing.....	15

**GENERAL PROVISIONS**

**R 408.12701 Scope.**

**Rule 2701.** This standard establishes standards for the safe installation, operation and maintenance of woodworking machinery and equipment, including the making of veneer. This standard applies to point of operation hazards on woodworking machinery.

**R 408.12702 Referenced MIOSHA standards.**

**Rule 2702.** The following Michigan Occupational Safety and Health Administrative (MIOSHA) standards are referenced in these rules. Up to 5 copies of these standards may be obtained at no charge from the Michigan Department of Licensing and Regulatory Affairs, MIOSHA Regulatory Services Section, 530 West Allegan Street, P.O. Box 30643, Lansing, Michigan, 48909-8143 or via the internet at website: [www.michigan.gov/mioshastandards](http://www.michigan.gov/mioshastandards). For quantities greater than 5, the cost, at the time of adoption of these rules, is 4 cents per page.

(a) General Industry Safety and Health Standard Part 2 "Walking-Working Surfaces," R 408.10201 to R 408.10241.

(b) General Industry Safety Standard Part 7 'Guards for Power Transmission,' R 408.10701 to R 408.10765.

**R 408.12705 Definitions A to C.**

**Rule 2705.** (1) "Aisle" means a path of travel for vehicles and employees.

(2) "Band saw" means a machine equipped with a lower and an upper wheel on which a continuous blade rides and past which the material is pushed.

(3) "Block" means a short block of wood, provided with a handle similar to that of a plane and a shoulder at the rear end and used for pushing stock over revolving cutters.

(4) "Circular saw" means a machine with a table to support the material and with a circular blade and used for ripping, cross-cutting, dadoing and rabbeting.

(5) "Combination or universal machine" means a machine combining several operations, including but not limited to sawing, jointing and drilling.

(6) "Cutter head" means a powered holder for a cutting blade.

**R 408.12706 Definitions D to J.**

**Rule 2706.** (1) "Drag Saw" means a chain saw on which an end of the chain arm is held at a fixed point with the opposite end moving in an arc downward through a log.

(2) "Guillotine veneer cutter" means a machine with a blade which cuts veneer by moving downward through the material, similar to a metal shear.

(3) "Interlocked barrier" means a guard attached to a machine and interlocked so that if the guard is not in place the machine will not start or, if running, the power will be cut off.

(4) "Inverted cut-off, jump saw" or "underslung saw" means a machine similar to a circular saw except the blade moves through stationary material.

(5) "Jointer" means a machine with a revolving cutter head set into an adjustable table over which the material is moved over the cutter head.

**R 408.12707 Definitions M to P.**

**Rule 2707.** (1) "Molding or sticker machine" means a machine equipped with revolving cutter heads and used to cut irregular contours on straight strips of wood.

(2) "Mortiser" means a boring machine used to cut square or rectangular holes.

(3) "Planer" means a machine with a revolving cutter head set above an adjustable table on which material is passed under the cutter head by powered rollers.

(4) "Point of operation" means the area of a machine where material is actually worked.

(5) "Profile or swing head lathe" means a machine with multiple fixed knives suspended from a carriage over revolving stock which shapes the stock to a predetermined design.

(6) "Push stick" means a narrow strip of wood or other soft material with a notch or sharp point on 1 end which is used to push material through a point of operation.

**R 408.12708 Definitions R to T.**

**Rule 2708.** (1) "Radial saw" means a machine with a circular blade suspended from a horizontal arm which is pulled through the material.

(2) "Revolving tool lathe" means a lathe where revolving multiple cutters shape cut revolving stock held between 2 points.

(3) "Router" means a machine with a revolving vertical cutter and a motor suspended over a table and used to cut to a predetermined design.

(4) "Run" means the distance from pulley to pulley.

(5) "Swing saw" means a machine suspended above a table and equipped with a circular blade which swings forward from an overhead pivot point.

(6) "Tenoner" means a machine equipped with horizontal and vertical circular blades to cut tenon and perform trimming operations.

**R 408.12709 Definitions V, W.**

**Rule 2709.** (1) "Veneer clipper" means a machine which cuts multiple layers of veneer to predetermined sizes.

(2) "Veneer jointer" means a machine which machines the edges of veneer.

(3) "Veneer rotary lathe" means a machine which peels thin pieces of veneer from a log as it revolves past a blade.

(4) "Veneer slicer" means a machine which cuts the pieces of veneer from a log by moving a vertical blade against the log.

(5) "Veneer splicer" means a machine which glues veneer along the edges to make a larger piece.

(6) "Walkway" means a path of travel for foot traffic only.

**PLANT LAYOUT**

**R 408.12711 Plant layout; machinery**

**Rule 2711.** (1) A machine shall be located to allow space in which to handle material without interference from or to employees or machines. A machine shall not be so placed to require the operator to stand in an aisle unless protection is provided.

(2) A machine shall be secured to a floor, foundation, bench, table or stand of sufficient strength and design to prevent overturning or unintentional movement. This subrule does not apply to portable hand tools.

(3) A machine shall be located so that light of 50 foot-candle power minimum intensity from both natural and artificial light falls on the work. Supplementary illumination at the point of operation shall be provided where necessary.

**R 408.12712 Plant layout; floors and aisles.**

**Rule 2712.** (1) An aisle for powered traffic moving in 1 direction at a time shall be not less than the width of the widest vehicle or load plus 3 feet.

(2) An aisle for powered traffic moving in 2 directions at a time shall be not less than twice the width of the widest vehicle or load plus 3 feet.

(3) Lines shall be painted on the floor, or a similar method may be used to mark an aisle.

(4) This rule applies to an aisle in a new layout after November 15, 1971.

(5) An existing aisle shall comply with this rule by January 1, 1973.

**MACHINES AND EQUIPMENT**

**R 408.12714 Machines and equipment; construction.**

**Rule 2714.** (1) The height of the table or working surface of a machine, auxiliary table, and supports shall be designed to provide for safety of the operator. An auxiliary table or supports shall be provided so that large or unwieldy pieces can be handled safely.

(2) The vibration of a machine shall not create a hazard to the operator.

(3) An arbor and mandrel shall have a firm and secure bearing.

(4) The frames and all exposed metal parts of electric woodworking machinery shall be grounded. A portable motor driving an electric tool shall be grounded unless it has approved double insulation.

**R 408.12716 Machines and equipment; controls.**

**Rule 2716.** (1) A machine shall have a mechanical or electrical power control to permit the operator to cut off the power from the machine without leaving his or her position at the work station.

(2) A woodworking machine shall not automatically restart upon restoration of power after a power failure. A machine wired to a 110 volt line before November 15, 1971, is excepted from this rule.

(3) Operating controls shall be located within reach of the operator while the operator is at his or her regular work station, making it unnecessary to reach over the cutters. The controls shall be installed to eliminate the danger of accidental activation. This subrule does not apply to a constant pressure control used only for setup purposes.

**R 408.12717 Machines and equipment; self-feed.**

**Rule 2717.** Automatic feeding devices on a machine should be installed where the nature of the work will permit. The feed rolls or other moving parts on a feeder attachment shall be covered or guarded to protect the operator from in-running nip points.

## SAWS

### **R 408.12718 Saws generally.**

**Rule 2718.** (1) A cut-off saw that strokes automatically without the operator's control of each stroke shall have a guard to keep the operator's hands from coming in contact with a blade.

(2) An automatic cut-off saw that strokes continuously without the operator being able to control each stroke shall not be used.

(3) To avoid overspeed caused by mounting a saw larger than intended, lugs shall be cast on saw frame or tables or another means shall be provided to limit the saw blade size that can be mounted.

(4) A circular saw fence shall be firmly secured to the table or table assembly without changing its alignment with the saw. For a saw with a tilting table or tilting arbor, the fence shall remain in alignment with the saw, regardless of the angle of the saw with the table.

(5) To insure exact alignment with the saw for all positions of the gauge, a circular saw gauge shall slide in grooves or tracks which are accurately machined.

(6) A hinged saw table in use shall be firmly secured in position and in true alignment with the saw.

### **R 408.12719 Saws; speeds.**

**Rule 2719.** (1) The operating speed as designated by the manufacturer shall be etched or otherwise permanently marked on a circular saw blade more than 20 inches in diameter. A saw blade shall not be operated at a higher speed than shown on the blade.

(2) When a marked saw blade is re-tensioned for a different speed, the marking shall be corrected to show the new speed.

### **R 408.12720 Cracked blades.**

**Rule 2720.** A cracked curricular saw blade shall not be repaired or used.

### **R 408.12721 Saws; circular.**

**Rule 2721.** The exposed part of the saw blade either beneath or behind a table shall be covered with an exhaust hood. If an exhaust system is not required, the exposed part shall be covered with a guard arranged to prevent accidental contact with the saw.

### **R 408.12722 Circular saw guards.**

**Rule 2722.** (1) A circular saw shall have a hood type guard covering the blade at all times when not in use.

(2) When in use, the hood type guard shall enclose that part of the blade above the table and that part of the blade above the material by adjusting automatically to the thickness of the material being cut, or it may be a fixed or manually adjusted hood type guard if the hood remains in contact with the material.

(3) A hood type guard shall be made of 14 gauge metal or thicker. Plastic may be used if it can resist blows and strains incidental to reasonable operation, adjusting and handling and is designed to protect the operator from flying splinters and broken saw teeth.

(4) The guard shall be made of material soft enough so that it will be unlikely to cause tooth breakage.

(5) The hood shall be mounted so that its operation will be positive, reliable and in true alignment with the saw. The mounting shall be of sufficient strength to resist any reasonable side thrust or other force tending to throw it out of line.

(6) Where a hood type guard cannot be used because of unusual shapes or cuts, a jig or fixture providing equal safety of the operator shall be used. On the completion of these operations, the guard shall be replaced immediately.

(7) A push stick shall be used in cutting short or narrow stock.

### **R 408.12723 Circular saw spreaders.**

**Rule 2723.** A hand fed circular rip saw shall have a spreader to prevent material from squeezing the saw or being thrown back at the operator. The spreader shall be made of steel, or its equivalent, and shall be thinner than the saw kerf and slightly thicker than the saw disk. It shall be at least 1 inch wide at the table to provide adequate stiffness or rigidity to resist any reasonable side thrust or blow tending to bend or throw it out of position. The spreader shall be attached so it will remain in true alignment with the saw even when either the saw or table is tilted. It should be placed so there is not more than 1/2 inch space between the spreader and the back of the saw when the largest saw is mounted in the machine. If a blade smaller than maximum permissible size is used, the spreader shall be moved to within 1/2 inch of the blade. A spreader need not be used in connection with grooving, dadoing or rabbeting. On the completion of such operations, the spreader shall be replaced immediately.

### **R 408.12724 Non-kickback fingers or dogs.**

**Rule 2724.** A hand fed circular rip saw shall have non-kickback fingers or dogs located to oppose the thrust or tendency of the saw to pick up the material or to throw it back at the operator. Non-kickback fingers or dogs shall be designed to provide holding power for all the thicknesses of material being cut.

### **R 408.12725 Multiple arbor saw guards.**

**Rule 2725.** Revolving multiple arbor saws shall be fully guarded in accordance with R 408.12722.

### **R 408.12726 Circular re-saw guards.**

**Rule 2726.** (1) A circular re-saw shall be guarded by a hood type guard or shield of metal above the saw. This guard or shield shall comply with R 408.12722.

(2) Each circular re-saw, except self-feed saws with a roller or wheel at back of the saw, shall have a spreader fastened securely behind the saw. The spreader shall be thinner than the saw kerf and slightly thicker than the saw disk.

**R 408.12727 Self-fed circular saw hoods.**

**Rule 2727.** (1) In addition to guards over blades, as specified in R 408.12722, feed rolls on a self-feed circular saw shall be protected by a hood or guard to prevent the hands of the operator from coming in contact with the in-running rolls at any point. The guard shall be constructed of not less than 14-gauge sheet metal or the equivalent, and the bottom of the guard shall come down to within 3/8-inch of the plane formed by the bottom of working surfaces or the feed rolls. This distance may be increased to 3/4-inch if the lead edge of the hood is extended to not less than 5 1/2-inches in front of the nip point between the front roll and the work.

(2) A self-feed circular rip saw shall have sectional non-kickback fingers along the full width of the feed rolls. They shall be located in front of the saw and arranged to be in continual contact with the wood being fed.

**R 408.12728 Swing and sliding cut-off saws.**

**Rule 2728.** (1) Swing and sliding cut-off saws or any other saw mounted above the table, except radial saws, shall have a hood-type guard designed so the upper half of the blade, arbor, and nut will be covered at all times. A hood-type guard or a device shall cover the lower half of the blade. It shall automatically adjust to the thickness of the stock. It shall remain in contact with the stock or table as it moves forward to cut or returns to the back of the table. It shall be constructed of not less than 14 gauge sheet metal or equivalent material and designed to protect the operator from flying splinters and broken saw teeth.

(2) Where the saw is used by employees for production-type repetitive cuts and the upper portion of the blade, including the saw arbor, is completely enclosed, in lieu of the self-adjusting lower blade guard required by subrule (1) of this rule, a swing saw shall be guarded by 1 of the following methods:

(a) A box-type guard as prescribed in Figure 1.

(b) A fixed or adjustable barrier guard which protects the operator from inadvertently coming in contact with the saw teeth of the bottom portion, from the front or sides, of the blade.

(c) A self-adjusting guard as prescribed in Figure 1A or 1B that will prevent employee exposure to the front of the saw blade by dropping onto the work piece before the blade starts the cut and remains in contact with the work piece until the saw is returned to the back of the table.

(3) A swing cut-off saw shall have an effective device to return the saw automatically to the back of the table when released at any point in its travel. The device shall not depend upon any rope, cord, or spring for its proper functioning. A device shall be installed which prevents a rebound of the saw blade. If there is a counterweight, bolts supporting the bar and counterweight shall have cotter pins and the counterweight shall be prevented from dropping by a bolt passing through both the bar and counterweight or a bolt put through the extreme end of the bar, or where the counterweight does not encircle the bar, a safety chain attached to it. If the counterweight is exposed to contact, it shall be enclosed by a guard to the floor area guard that will hold twice the weight of the counterweight.

(4) A swing cut-off saw shall have limit chains or other equally effective devices to prevent the saw from swinging beyond the front or back edges of the table, or beyond a forward position where the gullets of the lowest saw teeth will rise above the table top.

(5) A sliding cut-off saw may have the lower half of the blade guarded as prescribed in Figure 1C in a manner that will restrict employee exposure to the front of the teeth by the guard dropping onto the work piece before the teeth start the cut and remaining in contact with the work piece until the saw is returned to the back of the table or is adjusted to remain within 3/8 inch of the work piece at all times.

(6) Instead of the self-adjusting lower blade guard required by subrule (5) of this rule, the saw may be stroked by use of constant pressure controls located so that the operator cannot reach the saw blade. When the saw blade has been returned to its rearmost position, a lower enclosure or guard shall be provided to restrict inadvertent contact.

(7) Figures 1, 1A, 1B, and 1C read as follows:

### FIGURES 1, 1A, 1B, 1C - SWING SAW GUARDING

FIGURE 1 - FOR SWING SAW ONLY

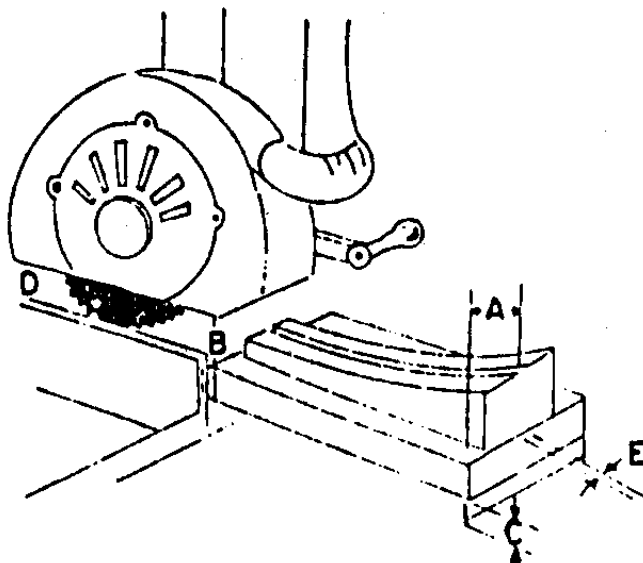

- A = Must be twice the 'C' dimensions, min. 6"
- B = 3/8" max.
- C = Open, depends on stock thickness
- D = 3/8" max.
- E = 1/4" max. on each side of black

FIGURE 1A - SWING SAW HOOD

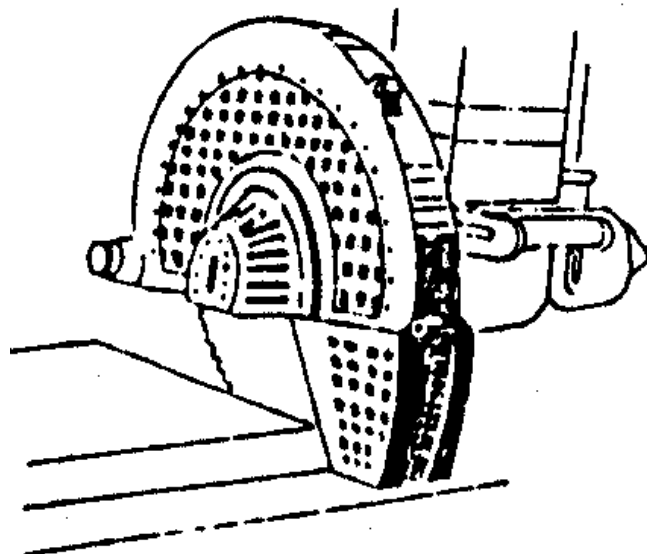

FIGURE 1B

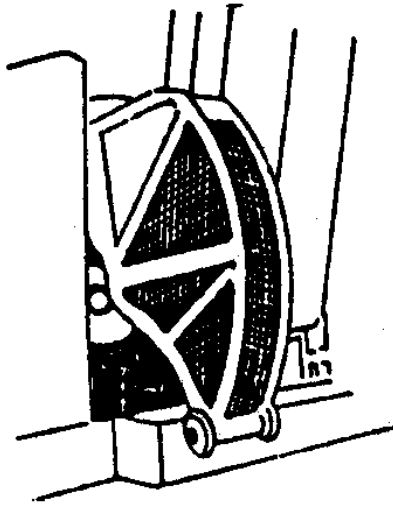
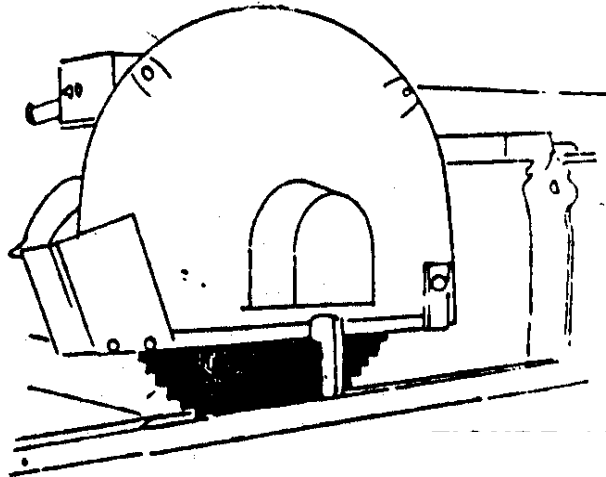

FIGURE 1C - SLIDE CUT OFF SAW GUARDING



**R 408.12729 Inverted swing cut-off, jump saws, underslung saws.**

**Rule 2729.** A hood type guard shall be securely fastened to the table that will cover the blade when running idle. The hood or guard shall extend not less than 2 inches in front of the saw teeth when the blade is in back position. A traveling guard shall move with the blade over the material and cover the exposed part of the blade above the material. The width of the hood shall be limited to provide not more than 1/4-inch clearance on each side of the blade.

**R 408.12730 Radial saws.**

**Rule 2730.** (1) The upper hood shall completely enclose the upper portion of the blade down to a point that will include the end of the saw arbor. The upper hood shall be constructed of not less than 14 gauge minimum sheet metal or equivalent material that will protect the operator from flying splinters and broken saw teeth and will deflect sawdust away from the operator. The teeth of the lower exposed portion of the blade shall be guarded to the full diameter of the blade by a device that will automatically adjust itself to the thickness of the stock and remain in contact with the stock being cut to give maximum protection possible for the operation being performed.

(2) In place of the requirements in subrule (1) of this rule, which require that the sides of the lower exposed portion of the blade be guarded by a device that will automatically adjust itself to the thickness of the stock being cut to give maximum protection possible for the operation being performed, both of the following apply:

(a) The employer is not required to provide an automatically adjusting guard on that side of the lower exposed portion of the blade where the distance between the stock and the upper hood guard is less than 3/8 of an inch (lower side) for angle, bevel, or compound level cuts.

(b) The employer may provide a specifically designed jig or fixture to protect the lower exposed portion of the blade in all cases where the distance between the stock and the upper hood guard exceed 3/8 of an inch (lower side) for angle, bevel, or compound bevel cuts. This specially designed jig or fixture shall provide protection for the operator which is equal to or greater than the protection required by subrule (1) of this rule.

(3) A box-type guard as prescribed in Figure 2 or a permanently mounted guard as prescribed in Figure 3 or other fixed or adjustable barrier guard that restricts employee exposure to the saw teeth may be used to protect the operator from inadvertently coming in contact with the teeth of the bottom portion, from the front or sides, of the blade in lieu of the self-adjusting lower blade guard if the upper portion of the blade, including the saw arbor, is completely enclosed.

(4) When radial saws are used for ripping, a spreader should be provided to comply with R 408.12723.

(5) Non-kickback fingers or dogs shall be located on both sides of each radial saw used for ripping to oppose the thrust or tendency of the saw to pick up the material or throw it back toward the operator. They shall be designed to provide adequate holding power for all the thickness of material being cut.

(6) An adjustable stop shall be provided to prevent the forward travel of the blade beyond the position necessary to complete the cut in repetitive operations. A limit chain or other equally effective device shall be provided to prevent the saw blade from sliding beyond the edge of the table or the table at that place shall be extended to eliminate overrun. The front end of the unit shall be slightly higher than the rear or shall meet the requirements of R 408.12728(3), so as to cause the cutting head to return gently to the starting position when released by the operator. The slope shall not be enough to cause rebound.

(7) Ripping and ploughing shall be against the direction in which the saw turns. The direction of the saw rotation shall be conspicuously marked on the hood. In addition, a permanent label colored standard danger red that is not less than 1-1/2 inches by 3/4 of an inch shall be affixed to the rear of the guard at approximately the level of the arbor. The label shall read as follows:

**DANGER:**  
**Do Not Rip or Plough From This End**

(8) Figures 2 and 3 read as follows:

**FIGURE 2**

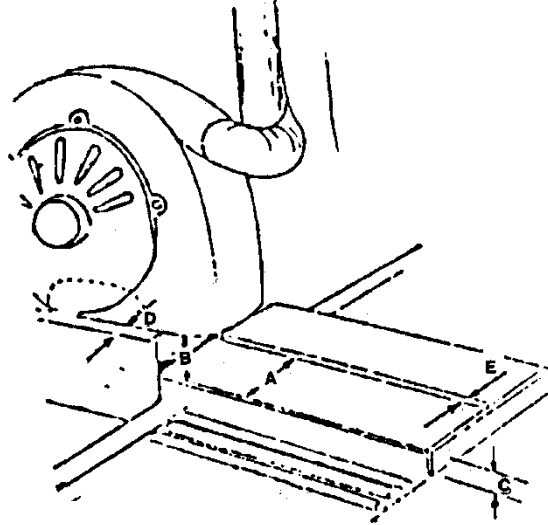

Dotted line in the bottom of guard shows possible relief if teeth are not exposed.

**FIGURE 3**

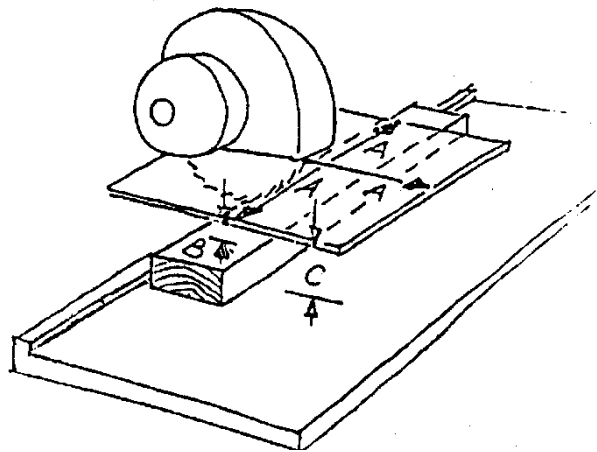

Dim.	Description	Requirements
A	Width of guard between each side or front of blade to outside edge of guard.	6 inches or twice "C", whichever is greater. Note: This dimension should be based on the greatest anticipated "C" distance.
B	Distance between upper hood guard and box guard (Fig.2) or bottom of mounted guard and stock (Fig. 3).	3/8-inch maximum.
C	Distance between top of work surface and bottom of guard.	
D	Distance between upper hood guard and fence.	3/8-inch maximum.
E	Distance allowed for saw blade travel in guard.	1/4-inch maximum on each side of blade.

**R 408.12731 Portable circular saws.**

**Rule 2731.** A portable, power driven saw shall have guards above and below the base plate or shoe. The upper guard shall cover the saw to the depth of the teeth, except for the minimum arc required to permit the base to be tilted for bevel cuts. The lower guard shall cover the saw to the depth of the teeth, except for the minimum arc required to allow proper retraction and contact with the work. When the tool is withdrawn from the work, the lower guard shall automatically and instantly return to the covering position.

**R 408.12732 Band saws.**

**Rule 2732.** (1) All portions of the band saw blade shall be enclosed or guarded except for the working portion of the blade between the bottom of the guide and the table.

(2) A band saw wheel shall be fully encased. The outside periphery of the enclosure shall be solid. The front and back of the band wheels shall be enclosed by either solid material, wire mesh, or perforated metal. Mesh or perforated metal shall be not less than 0.037-inch (U.S. Gauge No. 20) and the openings shall be not more than 3/8-inch. Solid material used for this purpose shall be of an equivalent strength and firmness. The upper wheel guard shall be made to conform to the travel of the saw on the wheel. The top member of the guard should have at least a 2-inch clearance outside the saw and be lined with smooth material.

(3) A guard for the portion of the blade between the sliding guide and the upper saw wheel guard shall protect the saw blade at the front and outer side. The guard shall be self-adjusting to raise and lower with the guide.

(4) The sliding blade guide shall be kept to within 1/4-inch of the work piece.

**R 408.12733 Band re-saw; feed rolls.**

**Rule 2733.** Feed rolls of band re-saws shall be protected with a suitable guard to prevent the hands of the operator from coming in contact with the in-running rolls at any point. The guard shall be constructed of 11 gauge sheet metal or stronger material, preferably metal. The edge of the guard shall come to within 3/8 inch of the plane formed by the inside face of the feed roll in contact with the stock being cut or the work table.

**JOINTERS AND PLANERS**

**R 408.12736 Jointers and planers; general.**

**Rule 2736.** (1) Each hand fed planer and jointer with a horizontal or vertical head shall have a cylindrical cutting head, the knife projection of which shall not extend more than 1/8-inch beyond the cylindrical body of the head.

(2) Square cutting heads shall not be used on jointers and planers.

(3) The opening in the jointer table shall be kept as small as possible. The clearance between the edge of the rear table and the cutter head shall be not more than 1/8-inch. The table throat opening shall be not more than 2 1/2 inches when tables are set or aligned for zero cut.

(4) A proper push block shall be used when jointing short or narrow stock.

**R 408.12737 Jointers; guards.**

**Rule 2737.** (1) A hand-fed jointer with a horizontal or vertical cutting head shall have an automatic guard covering all the sections of the cutting head on the working side of the fence or gauge. The guard shall effectively keep the operator's hand from coming in contact with the revolving knives. The guard shall adjust itself automatically to cover the unused portion of the head, and shall remain in contact with the material at all times.

(2) A hand fed jointer with a horizontal cutting head shall have a guard covering the section of the head back of the gauge or fence.

(3) Each wood jointer with vertical head shall have either an exhaust hood or other guard so arranged as to enclose completely the revolving head, except for a slot of such width as may be necessary and convenient for the application of the material to be jointed.

**R 408.12739 Tenoning machines and automatic edge banders.**

**Rule 2739.** (1) A tenoning machine and an automatic edge bander shall have all cutting heads and saws covered by guards. The guards shall cover at least the unused part of the periphery of the cutting head. If a guard is constructed of sheet metal, the material used shall be not less than 14 gauge in thickness. If cast iron is used, it shall be not less than 3/16 inch in thickness. Other materials of equivalent strength may be used. If interlocked barriers are used at load and unload ends the enclosure guards specified in this subrule need not be used. It is not required that the above hoods retain a thrown or broken knife.

(2) If an exhaust system is used on a tenoner or edge bander, the guard shall form part or all of the exhaust hood. It shall be constructed of material of a thickness not less than that specified in subrule (1) of this rule.

**R 408.12740 Double and tenoner drives.**

**Rule 2740.** (1) Feed chains and sprockets of double end tenoning machines shall be completely enclosed, as prescribed in General Industry Safety Standard, Part 7 "Guards for Power Transmission," as referenced in R 408.12702, except for that portion of chain used for conveying the stock.

(2) At the rear ends of frames over which feed conveyors run, sprockets and chains shall be guarded at the sides by plates projecting beyond the periphery of sprockets and the ends of lugs.

(3) The unloading end of the frame over which the feed conveyors run shall be extended so the material, as it leaves the machine, will be guided to a point where the operator cannot reach the point of operation.

**R 408.12741 Hold downs.**

**Rule 2741.** Hold downs shall be guarded with an enclosure to within 1/4 inch of the work piece or in accordance with Table 1.

TABLE 1	
Distance of Opening From Point of Operation Hazard	Maximum Width of Opening
1/2" to 1 1/2"	1/4"
1 1/2" to 2 1/2"	3/8"
2 1/2" to 3 1/2"	1/2"
3 1/2" to 5 1/2"	5/8"
5 1/2" to 6 1/2"	3/4"
6 1/2" to 7 1/2"	7/8"
7 1/2" to 12 1/2"	1 1/4"
12 1/2" to 15 1/2"	1 1/2"
15 1/2" to 17 1/2"	1 7/8"
17 1/2" to 31 1/2"	2 1/8"
This table shows the distances that guards shall be positioned from the danger line in accordance with the required feed openings.	

**R 408.12742 Hand fed tenoners.**

**Rule 2742.** Hand fed tenoning machines shall have a clamping or hold down device on the fixture to help the operator hold the material being cut.

**R 408.12744 Boring and mortising machines.**

**Rule 2744.** (1) A safety bit chuck without projecting set screws shall be used on a boring or mortising machine.

(2) Boring bits should have a guard enclosing all portions of the bit and chuck above the material being worked.

(3) The top of the cutting chain and driving mechanism on a chain mortiser shall be enclosed.

(4) If there is a counterweight, it shall be guarded as prescribed in R 408.12728(2).

(5) Universal joints and spindles of boring machines shall be guarded to prevent accidental contact by the operator.

**R 408.12751 Wood shapers.**

**Rule 2751.** (1) The cutting heads of a wood shaper, hand fed panel raiser or a similar machine not automatically fed shall be enclosed with a cage or adjustable guard designed to prevent contact with cutter blades by the operator's hands. The diameter of circular shaper guards shall be not less than the greatest diameter of the cutter. A warning device of leather or other material shall not be attached to the spindle. Prototype operations, involving a single item, where an usual configuration precludes the use of a guard, is exempt from this rule.

(2) Templates, jigs, and fixtures that remove the operator's hands from the point of operation shall be used when the nature of the work permits such use.

**R 408.12752 Double spindle shapers.**

**Rule 2752.** Double spindle shapers shall be provided with a spindle starting and stopping the device for each spindle.

**R 408.12755 Planing, molding, sticking, and matching machines.**

**Rule 2755.** (1) Each planing, molding, sticking, and matching machine shall have all cutting heads and saws covered by a metal guard. If the guard is constructed of sheet metal, the material used shall be not less than 14 gauge in thickness or the equivalent. If cast iron is used, it shall be not less than 3/16 inch in thickness. It is not required that the hoods retain a thrown or broken knife.

(2) If an exhaust system is used, the guards shall form part or all of the exhaust hood and shall be constructed of metal of a thickness not less than that specified in subrule (1) of this rule.

**R 408.12756 Feed rolls.**

**Rule 2756.** (1) A feed roll on a planing, molding, sticking or matching machine shall be guarded by a hood or suitable guard to prevent the hands of the operator from coming in contact with the in-running rolls at any point. The guard shall be fastened to the frame carrying the rolls so as to remain in adjustment for any thickness of stock.

(2) Surfacer or planers used in thickening multiple pieces of material simultaneously shall have sectional infeed rolls with sufficient yield in the construction of the sections to provide feeding contact pressure on the stock over the permissible range of variation in stock thickness specified or for which the machine is designed. In lieu of the yielding sectional rolls, suitable section kickback finger devices shall be provided at the infeed end.

**R 408.12759 Lathes.**

**Rule 2759.** (1) A profile or swing-head lathe shall have all cutting heads covered by a metal guard. If the guard is constructed of sheet metal, the material used shall be not less than 14 gauge in thickness or equivalent. If cast iron is used, it shall be not less than 3/16 inch in thickness. It is not required that the hoods retain a thrown or broken knife.

(2) Cutting heads on wood-turning lathes, whether rotating or not, shall be covered as completely as possible by hoods or shields, which should be hinged to the machines so they can be moved back for making adjustments.

(3) Shoe-last and spoke lathes, doweling machines, wood-heel turning machines, and other automatic wood-turning lathes of the rotating knife type shall be equipped with hoods enclosing the cutter blades completely, except at the contact points, while the stock is being cut.

(4) A revolving tool lathe used for turning stock held between the 2 centers shall be equipped with guards extending over the tops of the tool in order to prevent the work pieces from being thrown out of the machines if they become loose.

(5) A revolving tool lathe shall be equipped with a suction hood properly connected to an exhaust system. The hood shall be formed over the revolving tools to serve as a guard. They shall be constructed of metal of a thickness not less than that specified in subrule (1) of this rule.

**SANDING MACHINES**

**R 408.12761 Sanding machines.**

**Rule 2761.** Feed rolls of self-feed sanding machines shall be protected with a semi-cylindrical guard to prevent the hands of the operator from coming in contact with the in-running rolls at any point. The guard shall be constructed of not less than 18 gauge sheet metal or stronger material, preferably metal, and shall be firmly secured to the frame carrying the rolls to remain in adjustment for any thickness of stock. The bottom of the guard should come down to within 3/8 inch of a plane formed by the bottom or contact face of the feed roll where it touches the stock.

**R 408.12762 Drum sanding machines.**

**Rule 2762.** A drum sanding machine shall have an exhaust hood, or other guard if an exhaust system is not required, arranged to enclose the revolving drum, except for that portion of the drum above the table.

**R 408.12763 Disk sanding machines.**

**Rule 2763.** A disk sanding machine shall have the exhaust hood, or other guard if an exhaust system is not required, arranged to enclose the revolving disk, except for that portion of the disk above the table. The distance between the disk and the table edge shall be not more than 1/4-inch.

**R 408.12764 Belt sanding machines.**

**Rule 2764.** (1) Belt sanders shall have all pulleys enclosed including sides and periphery except the working end of an edge sander. An exhaust hood may be part of the guard.

(2) The edges of the unused run of the belt shall be guarded.

(3) These guards shall effectively prevent the hands or fingers of the operator from coming in contact with the nip points.

**WOODWORKING MACHINES**

**R 408.12767 Combination or universal woodworking machines.**

**Rule 2767.** On combination or universal woodworking machines, each point of operation shall be guarded as specified in the rules of this standard for each separate machine. The machines shall have a separate stopping and starting device for each point of operation.

**R 408.12768 Routers.**

**Rule 2768.** The pulleys, spindles and cutting tools on routers shall be guarded. Turn plates, jigs and fixtures requiring the operator's hands to be removed from the point of operation may be used as a point of operation guard.

**R 408.12769 Roll type glue spreaders.**

**Rule 2769.** (1) The feed rolls on a roll type glue spreader shall be guarded at all nip points. The bottom of the guard at the feed side shall come to within 3/8-inch of a plane formed by bottom or contact face of the feed roll where it touches the stock.

(2) A reversing bar or switch or a kick plate may be used in addition to the nip guard.

(3) The rolls shall be fully opened when they are being cleaned.

(4) A long-handled brush or swab shall be used to clean them.

**R 408.12770 Other machines not excluded.**

**Rule 2770.** The mention of specific machines in R 408.12721 to R 408.12769 does not exclude other woodworking machines from the requirement that suitable guards and exhaust hoods be provided to reduce to a minimum the hazard due to the point of operation of these machines.

**R 408.12773 Veneer steaming and soaking vats.**

**Rule 2773.** If the size of the stock handled permits, the size of the vat sections should be 9 feet or less.

**R 408.12774 Vat loading and unloading.**

**Rule 2774.** Either or both of the following means shall be used in loading and unloading veneer steam and soaking vats:

(a) Mechanical handling or conveying equipment shall be provided and designed so the logs are removed without the assistance of an employee at the edge of the veneer steam and soaking vat.

(b) The floor surface at the sides of the vats being used shall be anti-slip.

**R 408.12776 Ventilation.**

**Rule 2776.** (1) Veneer steam and soaking vats should be located in buildings or in special sheds heated in cold weather to keep the amount of steam at a minimum.

(2) Means shall be provided to ventilate buildings in which steam and soaking vats are located. High ceilings with roof ventilators or louvers are desirable. Where ceilings or roofs are under 15 feet, exhaust fans shall be provided.

**R 408.12781 Drag saws.**

**Rule 2781.** A drag saw shall be located at allow at least a 4-foot clearance for passage where the saw is at the extreme end of the stroke. If such clearance is not obtainable, the saw and its driving mechanism shall be provided with a guardrail system as prescribed in General Industry Safety and Health Standard Part 2 "Walking-Working Surfaces," as referenced in R 408.12702.

**VENEER MACHINES**

**R 408.12784 Veneer cutters.**

**Rule 2784.** (1) Slicer knives shall be guarded at both front and rear to prevent accidental contact with the knife edge.

(2) Veneer slicers and rotary veneer cutting lathes shall be shut off when logs are inserted or adjustments are made.

(3) Operators shall not ride the carriage of a veneer slicer.

(4) Power driven guillotine veneer cutters shall have 1 or both of the following:

(a) Starting devices that require the simultaneous action of both hands to start the cutting motion and of at least 1 hand on a control during the complete stroke of the knife.

(b) An automatic guard that will remove the hands of the operator from the danger zone at every descent of the blade, used in conjunction with 1 hand starting devices that require 2 distinct movements of the device to start the cutting motion and designed to return positively to the non-starting position after each complete cycle of the knife.

(5) Where 2 or more employees are engaged at the same time on the same power driven guillotine veneer cutter, the veneer machine shall have 2 hand controls for each employee and the device shall be arranged so each employee is required to use both hands simultaneously on the controls to start the cutting motion and at least 1 hand of each employee on a control to complete the cut.

(6) Power driven guillotine veneer cutters, other than continuous trimmers, shall be provided with an emergency device to prevent the machine from operating in the event of failure of the brake when the starting mechanism is in the non-starting position, in addition to the brake or other stopping mechanism.

(7) Where practicable, hand and foot-power guillotine veneer cutters shall be provided with rods or plates, or other satisfactory means, so arranged on the feeding side that the hands cannot reach the cutting edge of the knife while feeding or holding the stock in place.

(8) If veneer slicers or rotary veneer-cutting machines are shut down for the purpose of inserting logs or making adjustments, operators shall ensure that the machine is clear and other workmen are not in a hazardous position before starting the machine.

#### **R 408.12785 Veneer clippers.**

**Rule 2785.** (1) A veneer clipper shall have a guard to keep the fingers from the point of operation while feeding or removing the stock.

(2) The sprockets on a chain or slat belt conveyor of a veneer clipper shall be enclosed. It is recommended that conveyors or traveling tables be installed to remove material from clippers.

(3) Where 2 or more operators work on a veneer clipper, each shall have a control button which must be pressed simultaneously to activate the machine.

#### **R 408.12786 Veneer splicer.**

**Rule 2786.** A veneer splicer shall have a barrier at the feed end to keep fingers from the in-running pinch point.

#### **R 408.12787 Veneer jointers.**

**Rule 2787.** Saw blades and vertical heads on a veneer jointer shall be enclosed and 2 hand controls shall be provided for each operator and shall be held down until the cut is complete. Pinch points formed by a movable bed shall be guarded.

## **OPERATING RULES**

### **R 408.12791 Operating rules; inspection and maintenance.**

**Rule 2791.** (1) A supervisor or employee shall not remove or make inoperable any safety device or guard specified in this standard.

(2) Dull, badly set, improperly filed, or improperly tensioned saws shall be immediately removed from service before they begin to cause the material to stick, jam, or kickback when it is fed to the saw at a normal speed. Saws to which gum has adhered on the sides shall be immediately cleaned.

(3) Knives and cutting heads of woodworking machines shall be kept sharp, properly adjusted, and firmly secured. If 2 or more knives are used in 1 head, they shall be properly balanced.

(4) Bearings shall be kept free of lost motion and shall be well lubricated.

(5) Arbors of circular saws shall be free from play.

(6) The sharpening or tensioning of saw blades or cutters shall be done only by persons of demonstrated skill.

(7) A saw blade, cutter head, or tool collar shall not be placed or mounted on a machine arbor unless the tool has been machined as to size and shape to fit the arbor.

### **R 408.12792 Operating rules; selection of machines.**

**Rule 2792.** (1) Machines shall not be used for operations of such variety as to necessitate the removal of safeguards suitable for the usual service.

(2) The specific operations involving special hazards shall be assigned to machines suitable for such work.

### **R 408.12793 Operating rules; saw.**

**Rule 2793.** (1) The practice of inserting wedges between the saw disk and the collar to form what is commonly known as a wobble saw is prohibited.

(2) Tension on a band saw and re-saw should be released from the blade when not in use.

(3) The back thrust shall be adjusted carefully to the normal position of the band saw blade.

(4) A band saw shall not be stopped quickly by thrusting a piece of wood against the cutting edge of teeth when the power is off.

(5) To detect cracks or other defects, each band saw blade shall be carefully examined as it is put on and taken off the band wheel. Cracked saws or saws that indicate the probability of breakage shall be promptly removed to avoid injury to the saw and to the operator.

**R 408.12795 Operating rules; jointers.**

**Rule 2795.** The minimum length of the piece jointed shall be not less than 4 times the distance between the 2 tables. Neither half of the jointer table should be adjusted horizontally so that the clearance between the edge of the table and revolving knives is more than 1/4-inch.

**R 408.12796 Operating rules; lathes.**

**Rule 2796.** Material in a lathe shall be fastened securely to faceplates or between centers.

**R 408.12797 Guard substitutes.**

**Rule 2797.** Combs, featherboards, or suitable jigs shall be provided at the work place for use when a standard guard cannot be used as in dadoing, grooving, jointing, moulding, and rabbeting as prescribed in R 408.12722(6).

**R 408.12798 Clothing.**

**Rule 2798.** (1) Anti-kickback aprons shall be provided to the employee at no expense to the employee and shall be used where material can be kicked back.

(2) Operators of machines shall not wear loose-flowing garments, sleeves, and neckties.

(3) Operators of machines should not wear gloves while operating machines.



Michigan Occupational Safety and Health Administration  
PO Box 30643  
Lansing, Michigan 48909-8143  
For technical questions of this standard – Ph: 517-284-7750 (GISHD) or 517-284-7720 (CETD)  
To order copies of this standard – Ph: 517-284-7740

The Department of Labor and Economic Opportunity will not discriminate against any individual or group because of race, sex, religion, age, national origin, color, marital status, disability, or political beliefs. Auxiliary aids, services and other reasonable accommodations are available upon request to individuals with disabilities.