

# Environmental Sensor Station Tower Installation Inspection Procedure

## Description

This procedure describes the requirements for the installation inspection of environmental sensor station (ESS) towers.

## General Structure Inspection

### 1) Obtain project plans.

- Upon receiving a work assignment from MDOT, the inspector must contact the project office to coordinate an inspection schedule and obtain the project plans for structure location information. Inspector must review the project plans to verify which version of the special details are included and to ensure all structures requiring inspection are completed. Inspector should additionally obtain manufacturer's drawings and review. Record all observations on [MDOT form 1460](#).

### 2) Establish and record structure location.

- Record MDOT Region, County, Route, GPS coordinates (minimum 10 decimal places) and brief location description.

### 3) Inspect and record structure information.

- ESS Tower Boom and Lowering Device
  - Test the tower boom lowering mechanism to ensure it can be tilted to the ground for maintenance purposes. Inspect all connections. Check the boom lock bolt holes to confirm alignment with locking bolts. Check for loose connections at both center hinge connection and the tilt base hinge point. Note any cracked or unusual welds and any bolts that have been bent to align with holes in the hinge connections. At a minimum, each bolt end should be at least flush with the nut. If there is not at least a flush condition between the bolt end and the nut, record this in the inspection report. Record any hardware that is missing, damaged, or not in their proper location. Record any signs of corrosion, cracks, gouges, dents, etc.
- Environmental Sensor Connections
  - Visually inspect the condition of the environmental sensors and the environmental sensors connections to the center mast. Ensure all bolted connections have a locking device. Verify all devices have been attached according to the manufacturer specifications. Note any gaps between the bolted connections, and loose or missing hardware. All unused bolt holes on the structure should be filled using appropriately sized nuts and bolts. Record any deficiencies in the remarks section of the inspection report.

#### 4) Inspect and record anchor bolt information.

- Visually inspect the structure base and note any damage or corrosion of anchor bolts or nuts and any bolts that have been bent to align with holes in the tower base. Inspect welds in the base looking for cracks or unusual welds. Inspect the base and vertical support for corrosion, cracks, gouges, dents, etc. Inspect the condition of the concrete foundation, noting any spalling, cracks, voids, and general deterioration.
- Lock Washers
  - Verify all anchor bolt connections have lock washers.
- Anchor Bolt Plan
  - Attach a plastic tag to an anchor bolt between the base and the concrete foundation including the date of inspection, structure number, and inspector's name and organization or company.
- Sounding Anchor Nuts (Optional)
  - Hit the side of the top nuts and hit the top of the bolts using a 24 oz. hammer. This is done to check for loose nuts (leveling and top) and/or cracked or broken bolts. If the nuts are tight, there is a sharp ringing sound; if the nuts are loose, there is a dull sound. Visually check for any gaps between the nuts, washers and the base plate. Tap one side of each washer placing one hand on the washer opposite the side being tapped. If the washer moves, the nut is not properly tightened.
- Anchor Bolt Projection (P)
  - Measure and record the distance between the top of the top nut and the top of the anchor bolt. Note any bolts that are lower than the top of the nut and measure the depth. Record the measurement as a negative projection.
- Anchor Bolt Stand-Off Distance (S)
  - Measure and record the distance between the top of the concrete foundation and the bottom of the levelling nut. Note any stand-off distances greater than 1 inch in the remarks section of the inspection report.
- Anchor Bolt Ultrasonic Results
  - Ultrasonic Testing must be performed on all anchor bolts. The individual doing the ultrasonic testing (UT) must be qualified as ASNT Level II, on recommended practice SNT-TC-1A.

Calibrate the ultrasonic unit for straight beam probe method using a 10-inch screen. The probe is placed on a 1-inch calibration block (DSC block or section of anchor bolt) and the indications on the screen are adjusted so that a reflection is positioned at each inch mark. Next, place the probe on a 9-inch-long test bar that has a 1/8-inch-deep saw cut at a set distance (3 inches from the end) in the threaded portion of the rod. Peak the back reflection from the 1/8-inch-deep saw cut until the indication is at 60 or 80 percent of screen height. The dB reading is recorded to establish the "REFERENCE LEVEL." The "SCANNING LEVEL" is set by

adding 14 to 30 dB over the reference level. Calibration should be checked at each location before inspecting any bolts.

Grind all anchor bolt ends flat being sure to remove all galvanizing, paint, dirt, and debris. Ensure the surface is as smooth and flat as possible since surface imperfections 1/16 inch or greater can affect the UT results. Only grind the bolt a sufficient amount to remove any paint and smooth the surface.

Apply couplant (glycerin) to the ends of the bolts. Ultrasonically test the anchor bolts using a circular motion inspection pattern and record the results. When scanning the anchor bolts, there should be no indications on the CRT screen between the initial pulse and the end of the screen (10-inch depth). Any indication that is displayed after the initial pulse is a possible flaw. Record the depth of the discontinuity observed and the amount of dB required to bring the indication to the "REFERENCE LEVEL" on the screen. This is recorded as the "INDICATION LEVEL."

After the ultrasonic testing is complete, wipe off all the couplant with a wet rag, allow surface to dry completely, and spray the bolt ends with cold galvanizing or zinc-rich paint.

- Anti-Climb Panel
  - Verify anti-climb panels have been properly installed to restrict persons from climbing the tower lattice structure. Note any deficiencies in the remarks section of the report.

#### 5) Place structure ID label on upright.

- Structure Label
  - Install sticker label on structure noting Structure ID #. If sticker labels are not available, a stencil can be utilized in its place.

## Report Writing, Safety and Equipment

### Reporting Procedure

All reports must be detailed and accurate and will be used as evidence of work performed. All reports must have a minimum of one photo of the overall structure attached. Provide additional photos of deficiencies prior to submitting the report to MDOT. All reports must be uploaded to ProjectWise and submitted to [MDOT-Ancillary@michigan.gov](mailto:MDOT-Ancillary@michigan.gov). Files must be named as detailed below:

- 1460 Structure Number CS-JN Date
- Example: 1460 ESST-000001 82194-109971 2017-10-12

### Safety

All inspections and related work must be in accordance with the Department's Personal Protective Equipment (PPE) Policy as stated in the MDOT Guidance Document [10118](#) and MIOSHA safety standards (use of safety apparel and equipment safety guards). Safety apparel and equipment (hard hats, leather gloves, harnesses, lanyards, safety glasses, safety shoes, and safety vests) must be worn by all workers.

Any unusual or potentially dangerous conditions must be reported immediately to the Ancillary Structures Unit at [MDOT-Ancillary@michigan.gov](mailto:MDOT-Ancillary@michigan.gov).

### Equipment/Tool List

- Complete Ultrasonic Unit with Straight Beam Probe
- Distance and Sensitivity Calibration Block
- 8-10" calibration anchor bolt with a 1/8" cut 2-4" up from the bottom
- Couplant
- Rags
- Cold Galvanizing Spray or Zinc-Rich Paint
- Grinder
- 4 Foot Level
- 24 oz. Hammer
- Binoculars
- Identification Tags
- Yellow Paint Markers
- Tape Measure
- Voltage Detector
- MDOT Special Provisions [20SP-826M-01](#)
- MDOT Special Details [ITS-050-A](#), [ITS-051-B](#), [ITS-052-B](#), [ITS-053-A](#), and [ITS-054-A](#)
- [MDOT Form 1460: ESS Tower Installation Inspection Report](#)

# Inspection Reference Detail

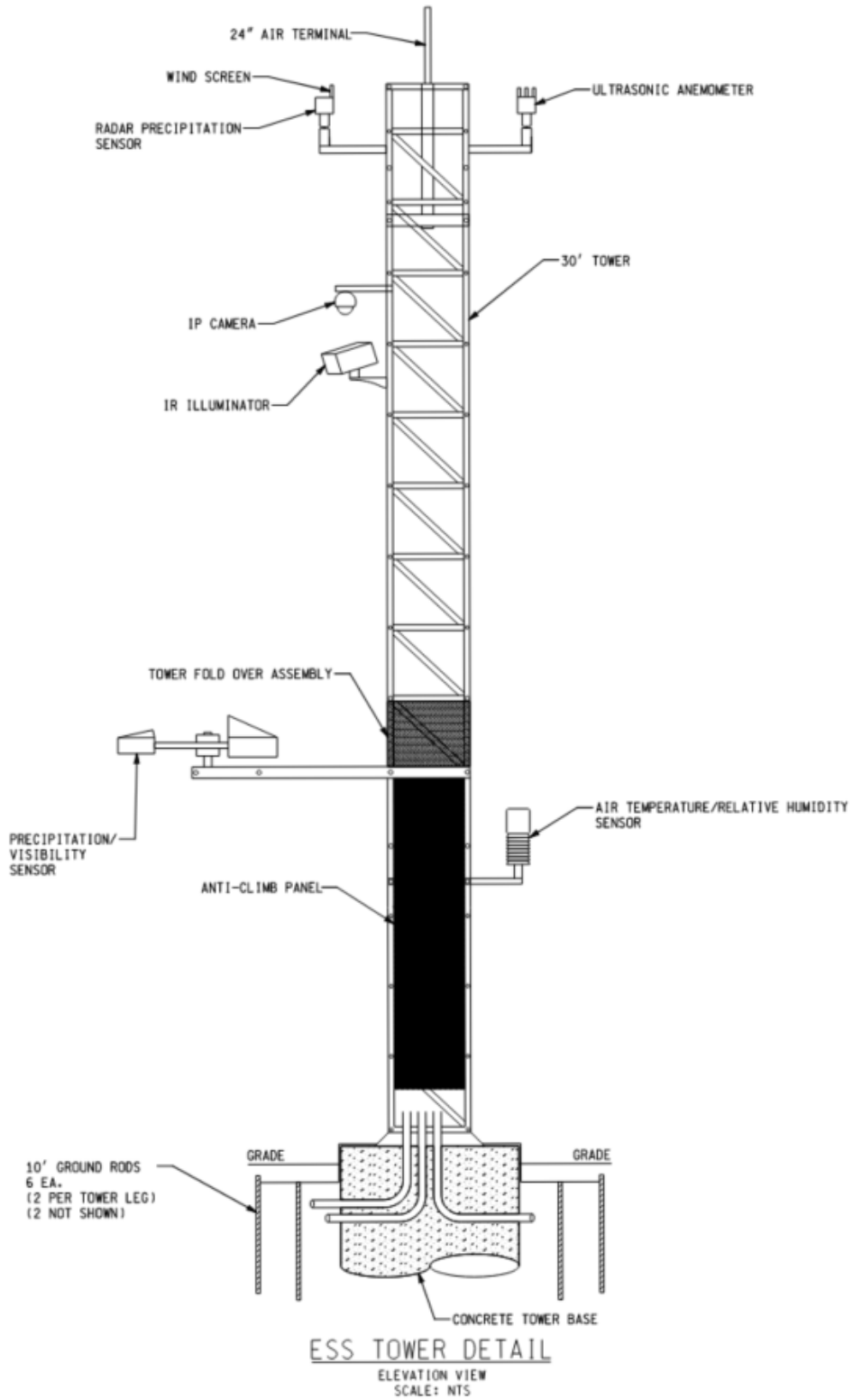

# Inspection Reference Detail

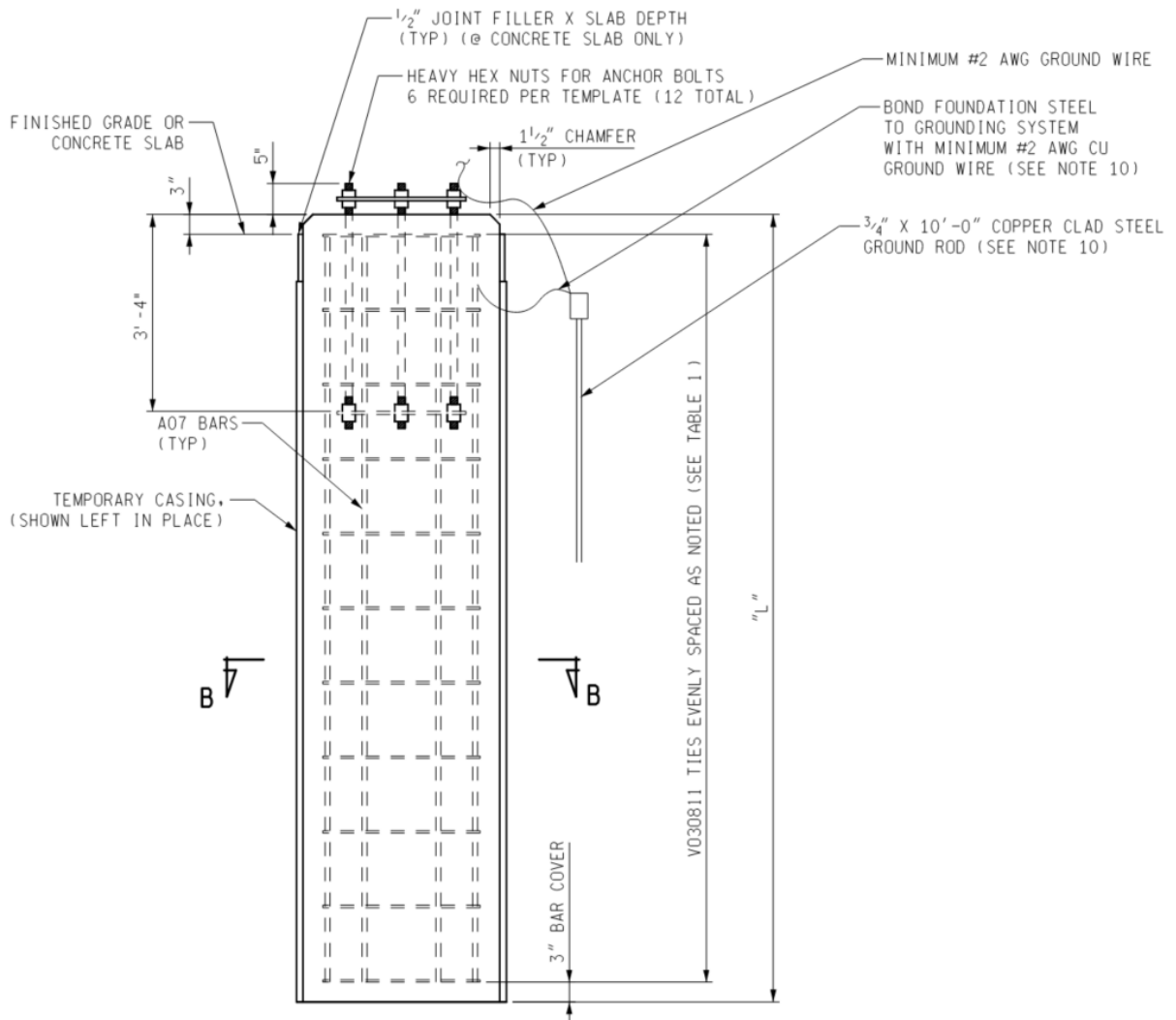
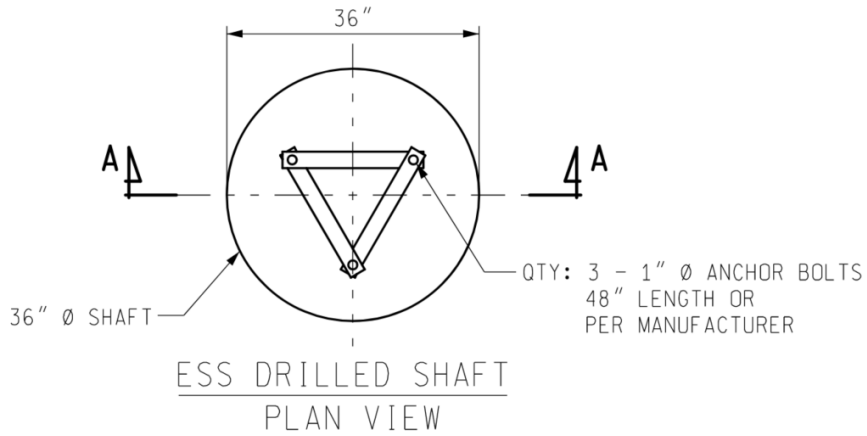

ESS DRILLED SHAFT  
SECTION A-A  
CONDUIT NOT SHOWN FOR CLARITY

# Inspection Reference Detail

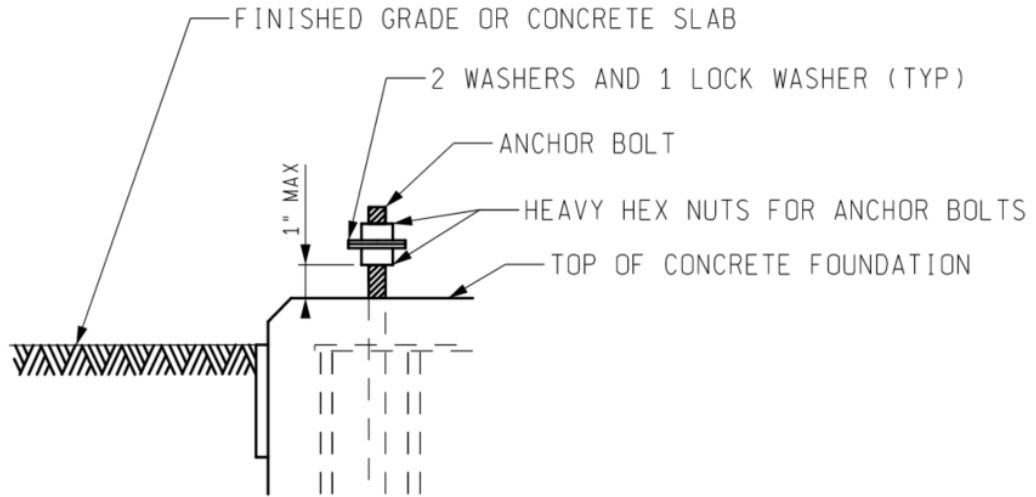

ANCHOR BOLT DETAIL  
PARTIAL ELEVATION

CONDUITS NOT SHOWN IN THIS VIEW FOR CLARITY.