

VEHICLE PACKET
FOR
MODIFIED MINI-VAN WITH RAMP



STATE OF MICHIGAN



Office of Passenger Transportation

Table of Contents

I. Introduction	3
II. Ordering Information	4
III. Accessible Passenger Floor Plans	5
IV. Title/Delivery Information & Post Delivery Audit	6
V. Acceptance/Inspection Checklist	14

I. Introduction

Purpose

This packet contains vehicle ordering information and related forms for purchasing from the State Vehicle Purchasing Program.

Instructions

1. Please read the *Guidelines for State Vehicle Purchasing Program* (available on the MDOT website <https://www.michigan.gov/mdot/travel/mobility/pub-transit/state-vehicle-contracts-and-procurement>) before ordering any vehicle. These Guidelines provide information, procedures, and a checklist to assist with a vehicle purchase.
2. Contact the dealer under “Ordering Information” (section II) to order a vehicle.
3. After receiving the vehicle, complete the Post Delivery Audit Work Sheets (section IV) and MDOT forms 3188 and 3189 (available on the MDOT website <https://www.michigan.gov/mdot/travel/mobility/pub-transit/state-vehicle-contracts-and-procurement>).

II. Ordering and Service Information

To order a vehicle, complete the separate New Vehicle Order Form (found on the MDOT State Vehicles & Contracts website under “**Accessible Passenger Vehicles**”). The form is a Microsoft Excel file and allows agencies to enter data while calculating costs.

Vehicle Type	Minivan with Ramp
Vendor	Transportation Equipment Sales Corp. (TESCO)
Mini-van State Vehicle Purchasing Program Contract No.	220000000793
Contract Period	05/01/2022 – 04/30/2024
Funding Sources	100% paid State and Federal on rear entry vans and <u>up to low bid price on order form</u> for side entry vans except optional equipment purchased outside of the contract.
Order Contact	Blair Taseff 6401 Seaman Road PO Box 167230 Oregon, OH 43618 800-227-3572 Office 440-653-0193 Mobile 419-836-8460 Fax btaseff@tescobus.com
Manufacturer	FR Conversions

Vehicle Type	Minivan with Ramp
Vendor	Hoekstra Transportation Inc.
Mini-van State Vehicle Purchasing Program Contract No.	220000000792
Contract Period	05/01/2022 – 04/30/2024
Funding Sources	100% paid State and Federal on side entry vans and <u>up to low bid price on order form</u> for rear entry vans except optional equipment purchased outside of the contract.
Order Contact	Steve Bolin 3741 Roger B. Chaffee Memorial Drive Grand Rapids, MI 49548 (616)389-1130 Fax: (616) 245-7736 SBolin@HoekstraTruck.com
Manufacturer	Braun

State of Michigan Contacts

Department of Technology, Management and Budget	Yvon Dufour Purchasing Operations (517) 249-0455 E-mail: DufourY@michigan.gov
MDOT	Jeff Turner Office of Passenger Transportation (517) 335-1700 Fax: (517) 373-1702 E-mail: turnerj3@michigan.gov

III. Accessible Passenger Vehicle Floor Plans

Modified Minivan

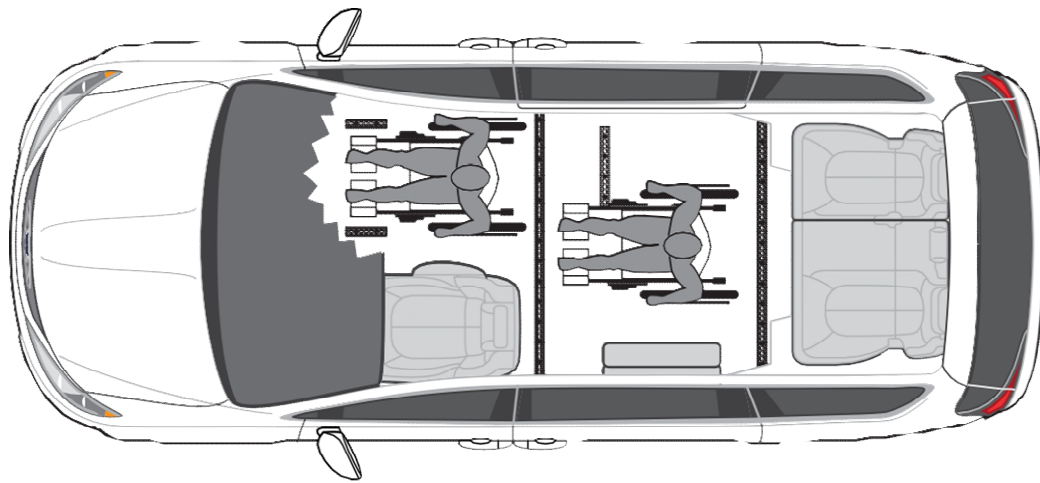

3+2 Modified Chassis Vehicle with ramp and one double fold-away seat (vinyl).

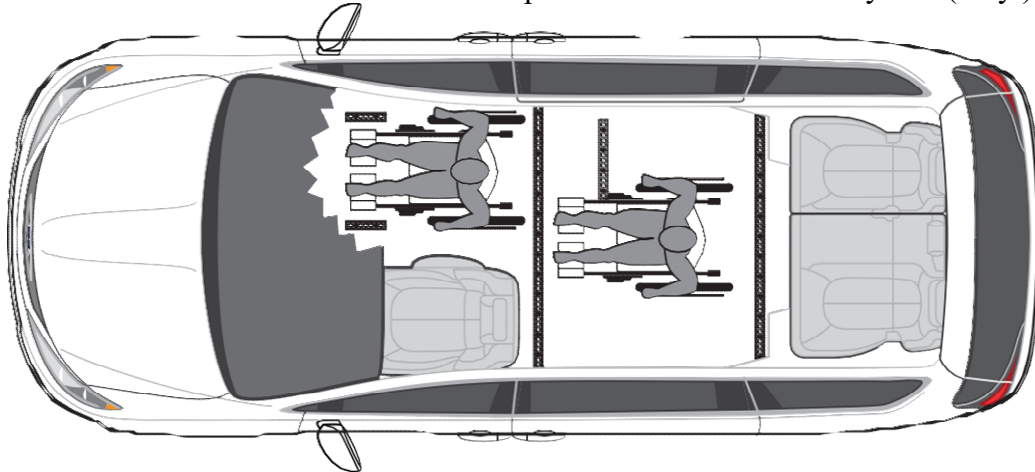

3+2 Modified Chassis Vehicle with ramp – vinyl (less double fold- away seat).

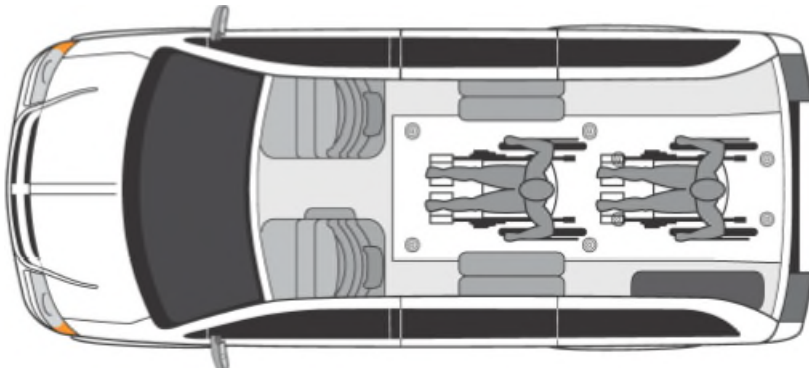

A. 4 + 2 Modified Chassis Vehicle with rear ramp and OEM Quad Seats

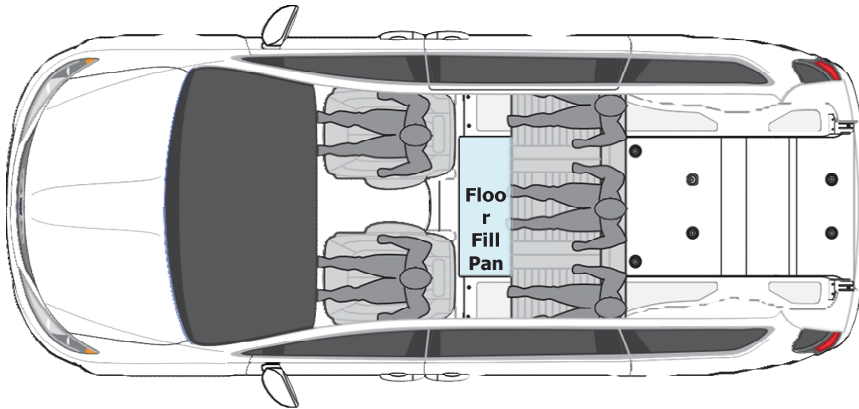

B. 5 Passenger Modified Chassis Vehicle with rear ramp with 1 WC and Cargo

**IV. TITLE/DELIVERY INFORMATION AND
POST DELIVERY AUDIT WORKSHEETS**

DATE _____

TRANSIT AGENCY _____

CONTRACT NO. _____ FED I.D. # _____

TITLE INFORMATION	
Name of City, County, or Agency	
Street Address (Post Office Box Not Acceptable)	
First Secured Party (if required)	
Tax I.D. Number	
City	Zip Code

DELIVERY ADDRESS		
Name of Operating Transit Agency		
Street Address (Post Office Box Not Acceptable)		
City	Zip Code	County
Contact Person	Telephone Number	

**Michigan Department of Transportation
Office of Passenger Transportation
POST-DELIVERY AUDITS
ATTACHMENT A-8
CHECKLIST**

Contract #		Vehicle Description	
Dealer		Manufacturer	
Contract Term		Contract Admin. (MDOT or Agency)	

Post Delivery Audit

	Item	Completion Date	Initials
1	Total cost of vehicles purchased in this order: \$ _____ If less than \$150,000, skip to #2 below. Do not complete or submit Attachments A10-12		
1.1	Buy America Certification stating regulations are still being met, if required		
2	Bid Certification		
2.1	Vehicle inspection		
2.2	Vehicle road test		
2.3	Were there 11 or more (Urban over 200,000 population) or 21 or more for (Rural or Urban under 200,000 population) vehicles purchased? Yes <input type="checkbox"/> No <input type="checkbox"/>		
2.4	If yes obtain Inspectors report*		
2.5	Certification vehicle meets bid specifications		
2.6	Federal Motor Vehicle Safety Standard's certification		

To be completed by Transit Agency

*The resident inspector's (*Administrative Fee can be used to hire inspector*) report must include, at a minimum:

- Accurate records of all bus construction activities (such as component manufacturing processes, final assembly activities, and quality control data collected)

and

- A description of how the construction and operation of the bus(es) fulfills the contract specifications (the report should reference the above cited manufacturing processes, final assembly activities, and quality control data).

**Michigan Department of Transportation
Office of Passenger Transportation
POST-DELIVERY AUDITS
ATTACHMENT A-9
FEDERAL MOTOR VEHICLE SAFETY STANDARDS CERTIFICATIONS**

Check one that applies:

- The vehicles proposed under this contract are subject to the Federal Motor Vehicle Safety Standards (FMVSS) issued by the National Highway Traffic Safety Administration (NHTSA) in part 571 of this title.
- The vehicles proposed under this contract are not subject to the Federal Motor Vehicle Safety Standards (FMVSS) issued by the National Highway Traffic Safety Administration (NHTSA) in part 571 of this title.

As required by Title 49 of the CFR, Part 663 – Subpart D, I have received a copy of the manufacturer’s self-certification information concerning these vehicles compliance with relevant Federal Motor Vehicle Safety Standards. I have had this certification in my possession at both the pre-award and post-delivery stages of the procurement.

Vehicle Description	
Dealer	
Manufacturer	
Recipient Contact Name	
Position Title	
Recipient Authorized Signature	
Date	

To be completed by Transit Agency

Vendor to provide Post-delivery FMVSS Certification

**Michigan Department of Transportation
Office of Passenger Transportation
POST-DELIVERY AUDITS
ATTACHMENT A-10
BUY AMERICA CERTIFICATION
Post-delivery**

As required by 49 CFR part 663 – Subpart C, _____ (the recipient) is satisfied that the vehicles to be received, _____ (the number and description of vehicles) from _____ (the manufacturer), meet the requirements of 49 U.S.C. 5323(j), as amended. The recipient , or its appointed auditor _____ (the auditor – not the manufacturer or its agent), has reviewed documentation provided by the manufacturer, which lists (1) the actual component and subcomponent parts of the vehicles identified by the manufacturer, country of origin, and cost; and (2) the actual location of the final assembly point for the vehicles, including a description of the activities that took place at the final assembly point and the cost of final assembly.

Print Name	
Recipient Authorized Signature	
Position Title	
Date	

To be completed by Transit Agency

**Michigan Department of Transportation
Office of Passenger Transportation
POST-DELIVERY AUDITS**

**ATTACHMENT A-11
BUY AMERICA POST-DELIVERY AUDIT
Component Parts**

	Component	Supplier/Manufacturer	Address	Country of Origin	Cost or % of Domestic Origin
1					
2					
3					
4					
5					
6					
7					
8					
9					
10					

Vendor:

Vendor's Signature: _____

PLEASE MAKE ADDITIONAL COPIES IF NECESSARY

Completed by vendor – vendor can provide actual domestic content worksheet

**Michigan Department of Transportation
Office of Passenger Transportation
POST-DELIVERY AUDITS**

**ATTACHMENT A-12
BUY AMERICA POST-DELIVERY AUDIT
Sub-component Parts**

	Subcomponent	Supplier/Manufacturer	Address	Country of Origin	Cost or % of Domestic Origin
1					
2					
3					
4					
5					
6					
7					
8					
9					
10					

Vendor:

Vendor's Signature: _____

PLEASE MAKE ADDITIONAL COPIES IF NECESSARY

Completed by vendor – vendor can provide actual domestic content worksheet

**Michigan Department of Transportation
Office of Passenger Transportation
POST-DELIVERY AUDITS**

**ATTACHMENT A-13
BID SPECIFICATION AUDIT CERTIFICATION
Post-Delivery**

I have road tested and visually inspected the vehicle purchased. I certify that the vehicle delivered under this contract meets the contract specifications used for this solicitation.

- There were fewer than eleven vehicles procured under this purchase.

- There were eleven or more vehicles procured under this purchase. A copy of the inspector's report is attached.

Vehicle Description	
Dealer	
Manufacturer	
Recipient Contact Name	
Position Title	
Recipient Authorized Signature	
Date	

To be completed by Transit Agency

V. Acceptance/Inspection Checklist

Accessible Passenger Vehicle Acceptance/Inspection Checklist can be found on Office of Passenger Transportation web site:

<https://www.michigan.gov/mdot/travel/mobility/pub-transit/state-vehicle-contracts-and-procurement>