

**State Vehicle Purchasing Program  
VEHICLE PACKET**

FOR

**SMALL CLASS OF BUSES**

Class I - 5 years/150,000 miles

Class II - 7 years/200,000 miles

18 & 22 Passenger Non-lift buses - Lift buses with Alternate Seating

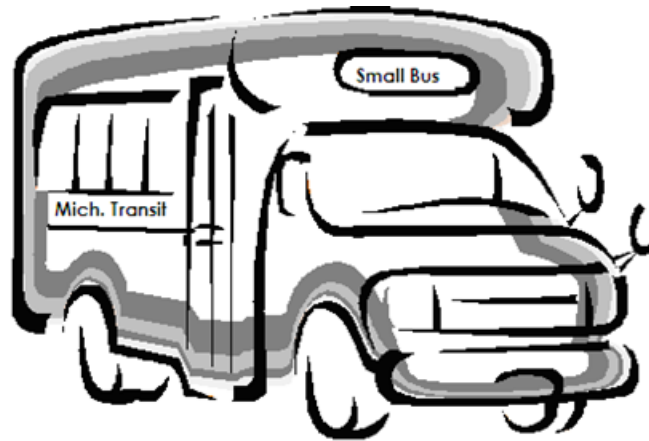

From April 1, 2021 to March 31, 2023

**STATE OF MICHIGAN**



**Office of Passenger Transportation  
Program Administration Section**

Contents

<b>I. INTRODUCTION.....</b>	<b>3</b>
<b>II. ORDERING AND SERVICE INFORMATION .....</b>	<b>4</b>
<b>III. VEHICLE INFORMATION .....</b>	<b>5</b>
<b>Light-Duty Small and Small Bus Floor Plans .....</b>	<b>5</b>
<b>Bus Color Sheet, Title and Delivery Information .....</b>	<b>11</b>
<b>IV. ACCEPTANCE/INSPECTION CHECKLIST.....</b>	<b>18</b>

# **I. Introduction**

## **Purpose**

This packet contains vehicle ordering information and related forms for purchasing from the State Vehicle Purchasing Program.

## **Instructions**

1. Please read the *State Vehicle Purchasing Program Guidelines* (available on the MDOT website) before ordering any vehicle. These guidelines provide information, procedures, and a checklist to assist with a vehicle purchase.
2. Complete the Bus Color Sheet (if ordering stripes and/or colors), Bus Title and Delivery Information, and New Vehicle Order Form (found on the MDOT State Vehicles & Contracts website under “Light-Duty Small” and “Small Bus”).
3. Submit the completed forms (section III) to the vendor.
4. After receiving the vehicle, complete the Post Delivery Audit Work Sheets (section IV).

## II. Ordering and Service Information

- To order a Light-Duty Small or Small bus, complete the separate New Vehicle Order Form (found on the MDOT State Vehicles & Contracts website under “Light-Duty Small” and “Small Bus”) for the respective bus vendor.

<b>Vendor</b>	<b>Hoekstra Transportation Class I &amp; II Fiberglass Reinforced Plastic and Class I &amp; II Metal Gage Bodies</b>	<b>TESCO Class I &amp; II Metal Gage Body</b>	<b>Shepard Brothers Class I &amp; II Metal Cage Body</b>
<b>State Vehicle Purchasing Program Contract #</b>	21000000606	21000000608	21000000609
<b>Funding Sources</b>	<b>Low bidder.</b> 100% paid State and Federal except optional equipment purchased outside of the contract.	State and Federal up to low bidder price. Balance paid locally along with optional equipment purchased outside of the contract.	State and Federal up to low bidder price. Balance paid locally along with optional equipment purchased outside of the contract.
<b>Order Contact</b>	<b>Steve Bolin</b> Commercial Products Manager/Contract Admin. Hoekstra Transportation, Inc. 3741 Roger B Chaffee Blvd. Grand Rapids, MI 49548 (616) 389-1130 Office (616) 299-5170 Mobile (616) 245-7726 Fax <a href="mailto:SBolin@HoekstraInc.com">SBolin@HoekstraInc.com</a>	<b>Blair Taseff</b> Regional Account Manager/Contract Admin. Transportation Equipment Sales Corp. (TESCO) 6401 Seaman Road PO Box 167230 Oregon, OH 43618 (800) 227-3572 Office (440) 653-0193 Mobile (419) 836-8460 Fax <a href="mailto:btaseff@tescobus.com">btaseff@tescobus.com</a>	<b>Jim Adams</b> Midwest Sales Manager 942 Surrey Way Cincinnati, OH 45245 (513) 752-1311 Office (513) 464-7707 Mobile (513) 752-4992 Fax <a href="mailto:jadams@shepardbrosinc.com">jadams@shepardbrosinc.com</a>
<b>Service Contact</b>	<b>Matt Reiffer</b> Service Manager 3741 Roger B Chaffee Memorial Dr Grand Rapids, Michigan 49548 (616) 245-7440 or (800) 444-4104 ext 1125 Fax: (616) 245-7726 <a href="mailto:MReiffer@HoekstraInc.com">MReiffer@HoekstraInc.com</a>	<b>Josh Wise</b> Warranty Manager 6401 Seaman Rd Oregon, Ohio 43616 419-720-7471 1-800-227-3572 <a href="mailto:jwise@tescobus.com">jwise@tescobus.com</a>	<b>Phillip Vollmer</b> PO Box 36, 130 Horizon Park Drive, Penn Yan, NY 14527 315-694-9071 Fax: 315-536-0460 <a href="mailto:PVollmer@coachandequipment.com">PVollmer@coachandequipment.com</a>
<b>Manufacturer</b>	<b>Eldorado &amp; Champion Buses</b> Tom Muldoon 331 Graham Road Imlay City, MI 48444 O (810) 721 – 7938 C (810) 310 – 1580 <a href="mailto:TMuldoon@forestriverinc.com">TMuldoon@forestriverinc.com</a>	<b>Glaval Bus</b> Mark Barczak Glaval Bus 2367 Century Dr Goshen, IN 46528 Office 800-348-7440 x 52115 Mobile 574-238-1219 <a href="mailto:mbarczak@forestriverinc.com">mbarczak@forestriverinc.com</a>	<b>Coach &amp; Equipment</b> 130 Horizon Park Drive Pen Yan, NY 14527 (315) 536-2321 Fax: (315)536-0460

### State of Michigan Contacts

<b>MDOT</b>	<b>Jeff Turner</b> Office of Passenger Transportation (517) 335-3282 Fax: (517) 335-1702 E-mail: <a href="mailto:turnerj3@michigan.gov">turnerj3@michigan.gov</a>	<b>Rob Pearson</b> <b>Supervisor BR&amp;IU</b> Office of Passenger Transportation (517) 930-3680 Fax: (517) 335-1702 E-mail: <a href="mailto:PearsonR1@michigan.gov">PearsonR1@michigan.gov</a>
-------------	---	--

### III. Vehicle Information

#### Light-Duty Small and Small Bus Floor Plans

**Class I  
Wheelbase 138" Minimum**

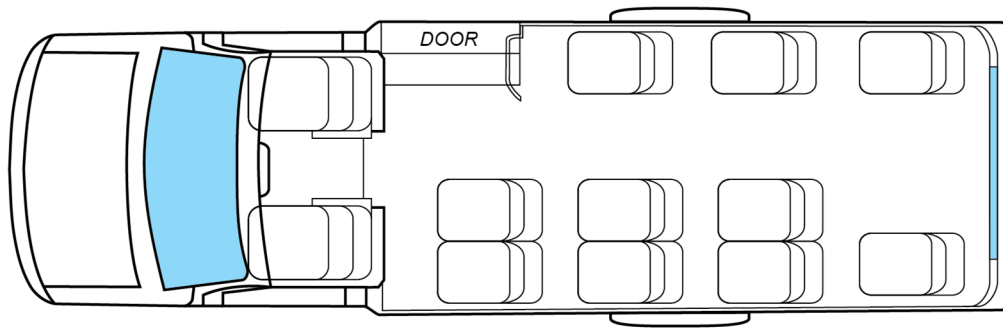

**10 Passenger Bus without Lift**

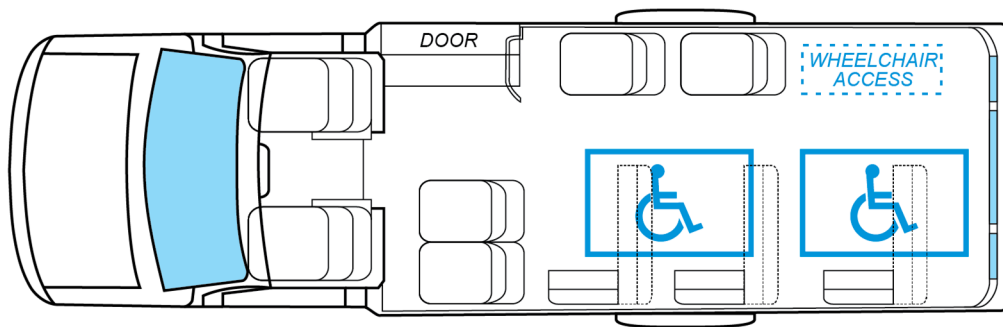

**4 + 2 Passenger Bus with Lift**

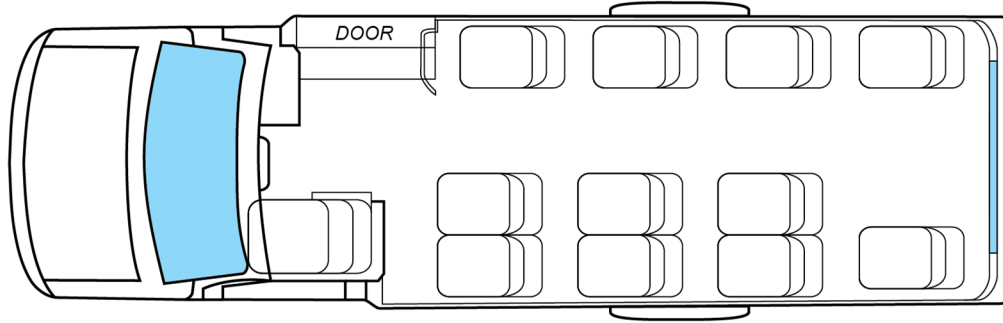

**11 Passenger Bus without Lift**

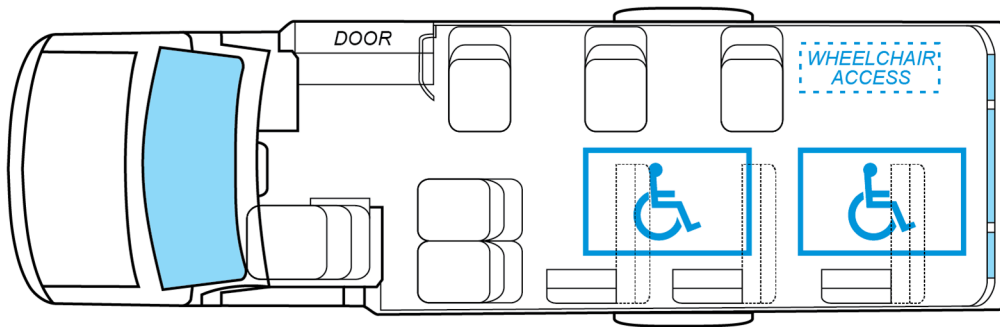

**5 + 2 Passenger Bus with Lift**

**Class II  
Wheelbase 158" Minimum**

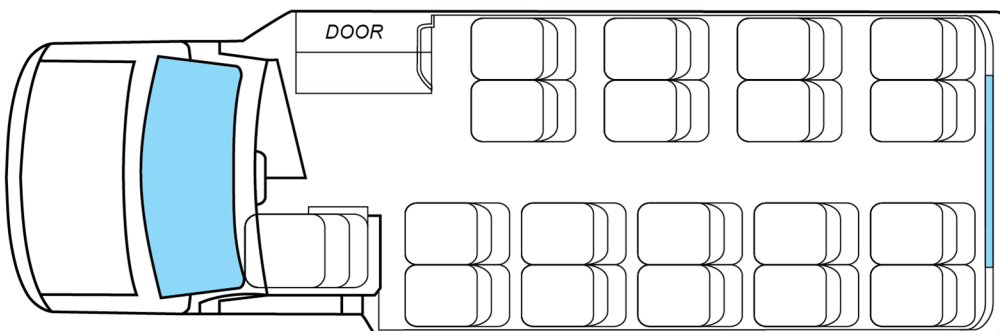

**18 Passenger Bus without Lift**

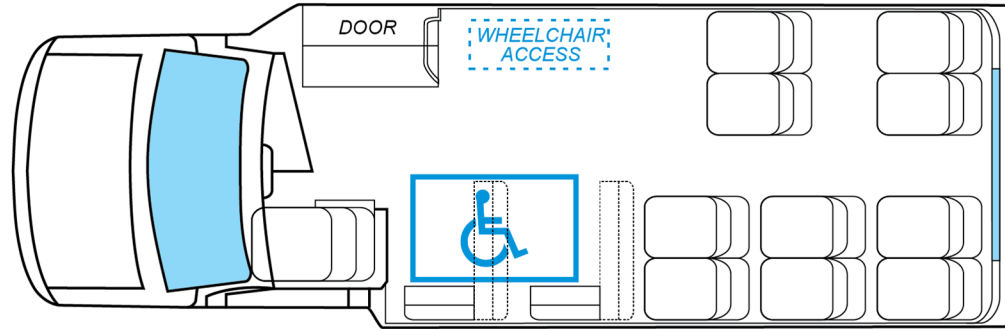

**10 + 1 Passenger Bus with Lift**

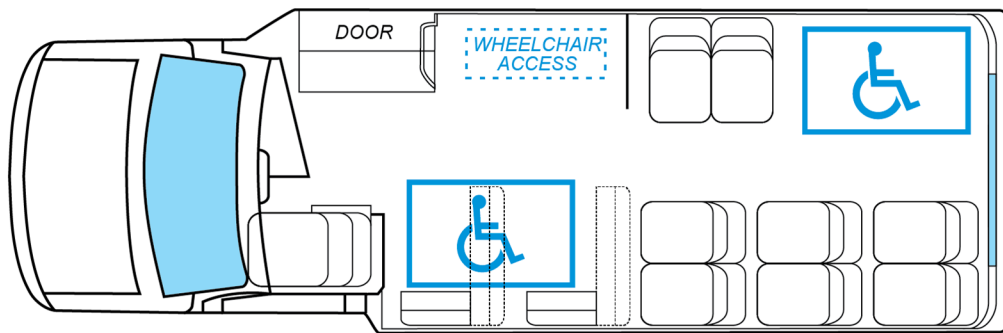

**8 + 2 Passenger Bus with Lift**

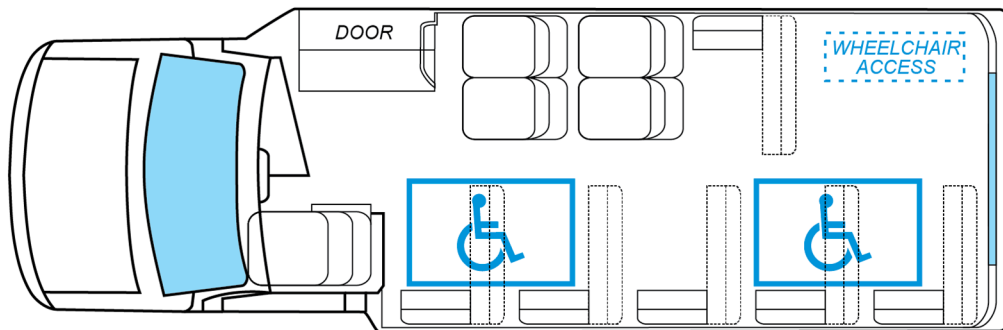

**4 + 2 Passenger Bus with Lift**

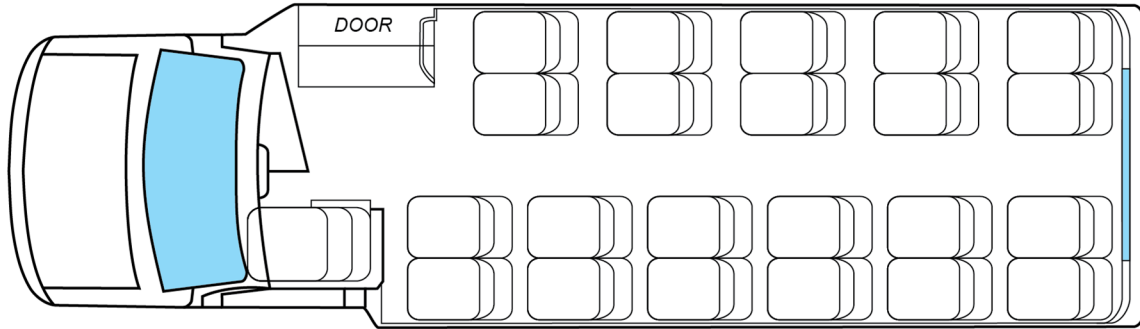

**22 Passenger Bus without Lift**

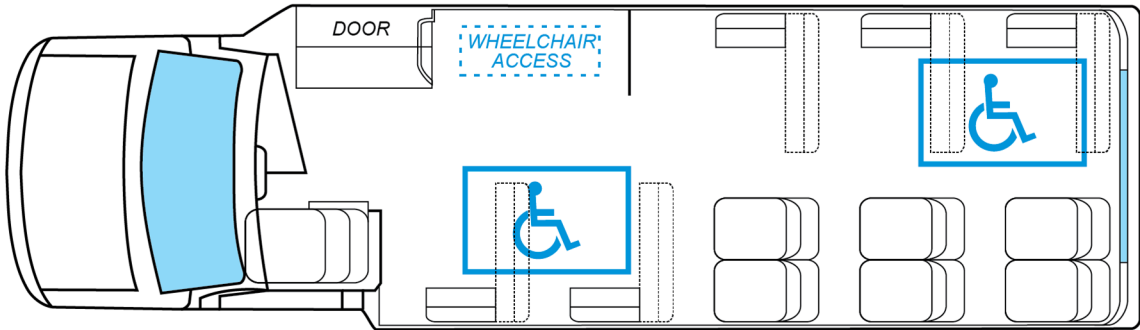

**6 + 2 Passenger Bus with Lift**

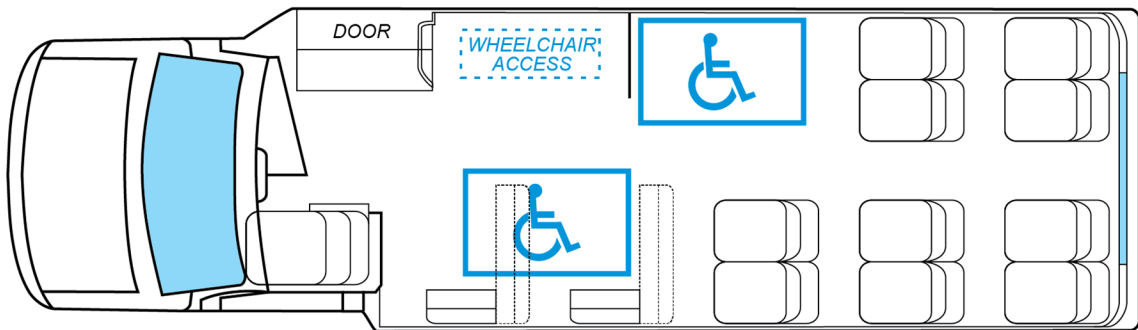

**10 + 2 Passenger Bus with Lift**



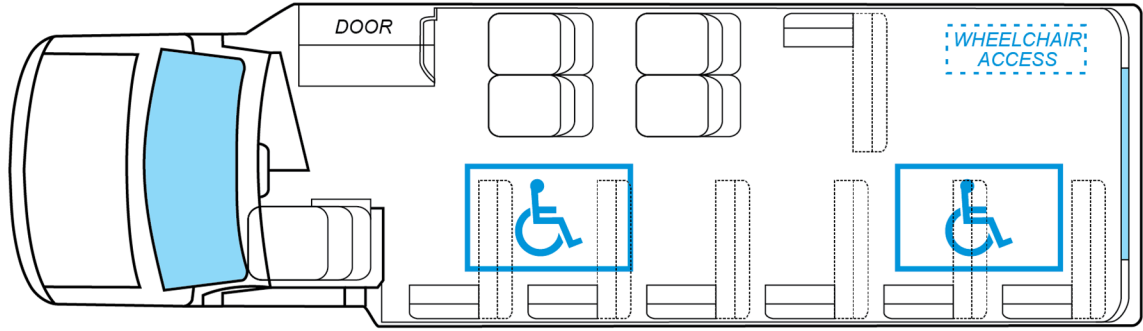

**4 + 2 Passenger Bus with Lift**

# Bus Color Sheet

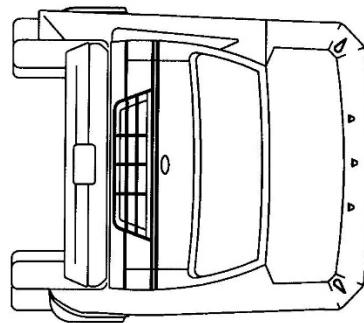
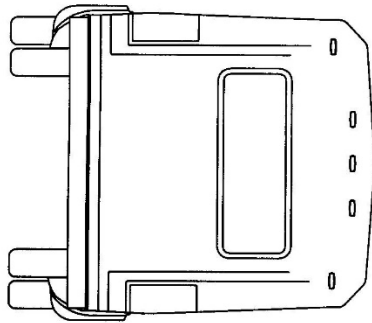
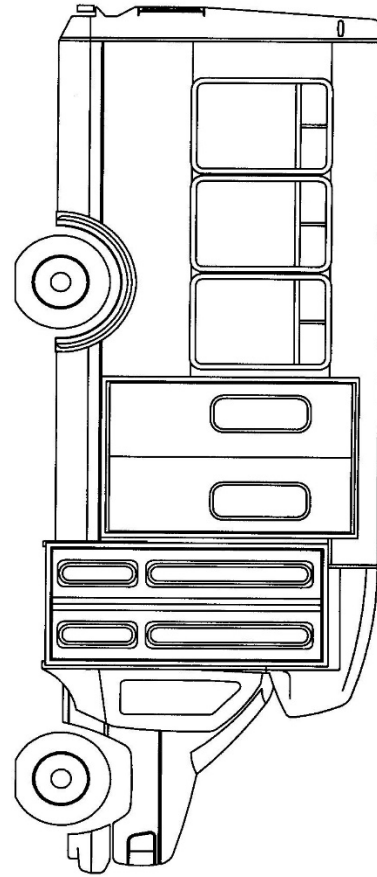
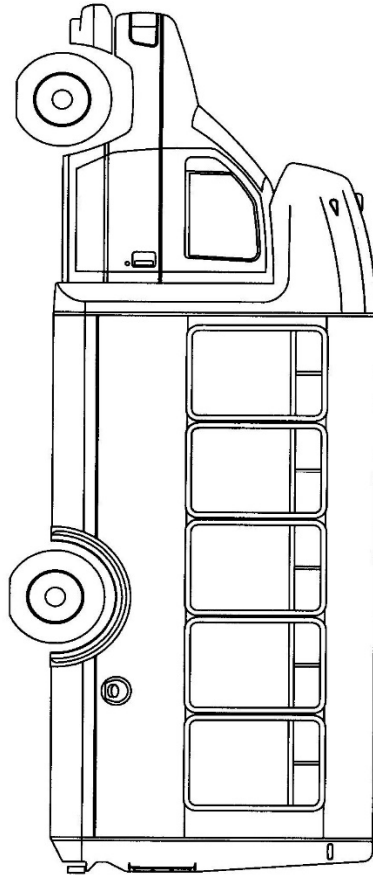

**Bus Title and Delivery Information**

DATE \_\_\_\_\_

TRANSIT AGENCY \_\_\_\_\_

CONTRACT NO. \_\_\_\_\_ FED I.D. # \_\_\_\_\_

<b>TITLE INFORMATION</b>	
<b>Name of City, County, or Agency</b>	
<b>Street Address (Post Office Box Not Acceptable)</b>	
<b>First Secured Party (if required)</b>	
<b>Tax I.D. Number</b>	<b>Ford FIN Number</b>
<b>City</b>	<b>Zip Code</b>

<b>DELIVERY ADDRESS</b>		
<b>Name of Operating Transit Agency</b>		
<b>Street Address (Post Office Box Not Acceptable)</b>		
<b>City</b>	<b>Zip Code</b>	<b>County</b>
<b>Contact Person</b>	<b>Telephone Number</b>	

**Michigan Department of Transportation  
Office of Passenger Transportation  
POST-DELIVERY AUDITS  
ATTACHMENT A-8  
CHECKLIST**

Contract #		Vehicle Description	
Dealer		Manufacturer	
Contract Term		Contract Admin. (MDOT or Agency)	

Post Delivery Audit

	Item	Completion Date	Initials
1	Total cost of vehicles purchased in this order: \$ _____ If less than \$150,000, skip to #2 below. Do not complete or submit Attachments A10-12		
1.1	Buy America Certification stating regulations are still being met, if required		
2	<b>Bid Certification</b>		
2.1	Vehicle inspection		
2.2	Vehicle road test		
2.3	Were there 11 or more (Urban over 200,000 population) or 21 or more for (Rural or Urban under 200,000 population) vehicles purchased? Yes <input type="checkbox"/> No <input type="checkbox"/>		
2.4	If yes obtain Inspectors report*		
2.5	Certification vehicle meets bid specifications		
2.6	Federal Motor Vehicle Safety Standard's certification		

**To be completed by Transit Agency**

\*The resident inspector's (*Administrative Fee can be used to hire inspector*) report must include, at a minimum:

- Accurate records of all bus construction activities (such as component manufacturing processes, final assembly activities, and quality control data collected)

**and**

- A description of how the construction and operation of the bus(es) fulfills the contract specifications (the report should reference the above cited manufacturing processes, final assembly activities, and quality control data).

**Michigan Department of Transportation  
Office of Passenger Transportation  
POST-DELIVERY AUDITS  
ATTACHMENT A-9  
FEDERAL MOTOR VEHICLE SAFETY STANDARDS CERTIFICATIONS**

Check one that applies:

- The vehicles proposed under this contract are subject to the Federal Motor Vehicle Safety Standards (FMVSS) issued by the National Highway Traffic Safety Administration (NHTSA) in part 571 of this title.
  
- The vehicles proposed under this contract are not subject to the Federal Motor Vehicle Safety Standards (FMVSS) issued by the National Highway Traffic Safety Administration (NHTSA) in part 571 of this title.

As required by Title 49 of the CFR, Part 663 – Subpart D, I have received a copy of the manufacturer’s self-certification information concerning these vehicles compliance with relevant Federal Motor Vehicle Safety Standards. I have had this certification in my possession at both the pre-award and post-delivery stages of the procurement.

Vehicle Description	
Dealer	
Manufacturer	
Recipient Contact Name	
Position Title	
Recipient Authorized Signature	
Date	

**To be completed by Transit Agency**

Vendor to provide Post-delivery FMVSS Certification

**Michigan Department of Transportation  
Office of Passenger Transportation  
POST-DELIVERY AUDITS  
ATTACHMENT A-10  
BUY AMERICA CERTIFICATION  
Post-delivery**

As required by 49 CFR part 663 – Subpart C, \_\_\_\_\_ (the recipient) is satisfied that the vehicles to be received, \_\_\_\_\_ (the number and description of vehicles) from \_\_\_\_\_ (the manufacturer), meet the requirements of 49 U.S.C. 5323(j), as amended. The recipient , or its appointed auditor  \_\_\_\_\_ (the auditor – not the manufacturer or its agent), has reviewed documentation provided by the manufacturer, which lists (1) the actual component and subcomponent parts of the vehicles identified by the manufacturer, country of origin, and cost; and (2) the actual location of the final assembly point for the vehicles, including a description of the activities that took place at the final assembly point and the cost of final assembly.

Print Name	
Recipient Authorized Signature	
Position Title	
Date	

**To be completed by Transit Agency**

**Michigan Department of Transportation  
Office of Passenger Transportation  
POST-DELIVERY AUDITS**

**ATTACHMENT A-11  
BUY AMERICA POST-DELIVERY AUDIT  
Component Parts**

	<b>Component</b>	<b>Supplier/Manufacturer</b>	<b>Address</b>	<b>Country of Origin</b>	<b>Cost or % of Domestic Origin</b>
<b>1</b>					
<b>2</b>					
<b>3</b>					
<b>4</b>					
<b>5</b>					
<b>6</b>					
<b>7</b>					
<b>8</b>					
<b>9</b>					
<b>10</b>					

**Vendor:**

**Vendor's Signature:** \_\_\_\_\_

**PLEASE MAKE ADDITIONAL COPIES IF NECESSARY**

Completed by vendor – vendor can provide actual domestic content worksheet

**Michigan Department of Transportation  
Office of Passenger Transportation  
POST-DELIVERY AUDITS**

**ATTACHMENT A-12  
BUY AMERICA POST-DELIVERY AUDIT  
Sub-component Parts**

	<b>Subcomponent</b>	<b>Supplier/Manufacturer</b>	<b>Address</b>	<b>Country of Origin</b>	<b>Cost or % of Domestic Origin</b>
<b>1</b>					
<b>2</b>					
<b>3</b>					
<b>4</b>					
<b>5</b>					
<b>6</b>					
<b>7</b>					
<b>8</b>					
<b>9</b>					
<b>10</b>					

**Vendor:**

**Vendor's Signature:** \_\_\_\_\_

**PLEASE MAKE ADDITIONAL COPIES IF NECESSARY**

Completed by vendor – vendor can provide actual domestic content worksheet



**Michigan Department of Transportation  
Office of Passenger Transportation  
POST-DELIVERY AUDITS  
ATTACHMENT A-13  
BID SPECIFICATION AUDIT CERTIFICATION  
Post-Delivery**

I have road tested and visually inspected the vehicle purchased. I certify that the vehicle delivered under this contract meets the contract specifications used for this solicitation.

- There were fewer than eleven vehicles procured under this purchase.
- There were eleven or more vehicles procured under this purchase. A copy of the inspector's report is attached.

Vehicle Description	
Dealer	
Manufacturer	
Recipient Contact Name	
Position Title	
Recipient Authorized Signature	
Date	

**To be completed by Transit Agency**

## **IV. Acceptance/Inspection Checklist**

Small Light-duty Bus Vehicle Acceptance/Inspection Checklist can be found on Office of Passenger Transportation web site:

[https://www.michigan.gov/mdot/0,4616,7-151-9625\\_21607\\_54929-249435--,00.html](https://www.michigan.gov/mdot/0,4616,7-151-9625_21607_54929-249435--,00.html)

Small Bus Vehicle Acceptance/Inspection Checklist can be found on Office of Passenger Transportation web site:

[https://www.michigan.gov/mdot/0,4616,7-151-9625\\_21607\\_54929-226501--,00.html](https://www.michigan.gov/mdot/0,4616,7-151-9625_21607_54929-226501--,00.html)