



# MICHIGAN'S 2019 Roads & Bridges ANNUAL REPORT



Michigan  
Transportation Asset  
Management Council

# ACRONYMS AND ABBREVIATIONS

**Any reference to Act 51 in this document refers to Public Act 51 of 1951, as amended.**

ADARS: Act-51 Distribution and Reporting System

APWA: American Public Works Association

BCFS: Bridge Condition Forecasting System

CPM: Capital Preventive Maintenance

CRA: County Road Association (of Michigan)

CSS: Center for Shared Solutions (DTMB)

CTT: Center for Training and Technology (MTU)

DTMB: Department of Technology, Management and Budget

EGL: Department of Environment, Great Lakes, and Energy

FHWA: Federal Highway Administration

FAST: Fixing America's Surface Transportation Act

IBR: Inventory Based Rating (Gravel Roads)

IRT: Investment Reporting Tool

MAC: Michigan Association of Counties

MAR: Michigan Association of Regions

MDNR: Michigan Department of Natural Resources

MDOT: Michigan Department of Transportation

MIC: Michigan Infrastructure Council

MML: Michigan Municipal League

MPO: Metropolitan Planning Organization

MTA: Michigan Township Association

MTPA: Michigan Transportation Planning Association

MTU: Michigan Technological University

NBI: National Bridge Inventory

NBIS: National Bridge Inspection Standards

NFC: National Functional Classification

NHS: National Highway System

PASER: Pavement Surface Evaluation and Rating

RPA: Regional Planning Agency

STIP: State Transportation Improvement Program

TAMC: Transportation Asset Management Council

TAMP: Transportation Asset Management Plan

WAMC: Water Asset Management Council

**TAMC was created by Public Act (PA) 499 Of 2002**

**To act as a resource for independent objective data on the condition of Michigan's roads and bridges and a resource for implementing the concepts of asset management.**

# TRANSPORTATION ASSET MANAGEMENT COUNCIL (TAMC)

## A Special Thanks:

### CSS

John Clark  
Clint Crick

Cheryl Granger  
Jeri Kaminski

### MDOT

Jacob Armour  
Roger Belknap  
Keith Cooper  
Eric Costa  
Beckie Curtis

Jesus Esparza  
Mayah Hanson  
Dave Jennett  
Matt Moulton  
Gloria Strong

### MTU

Tim Colling

Chris Gilbertson



## TAMC members for 2019 and the organizations they represent:

**Joanna Johnson (TAMC Chair)**, County Road Association of Michigan

**William McEntee (TAMC Vice-Chair)**, County Road Association of Michigan

**Derek Bradshaw**, Michigan Association of Regions

**Christopher Bolt, P.E.**, Michigan Association of Counties

**Gary Mekjian, P.E.**, Michigan Municipal League

**Bob Slattery Jr.**, Michigan Municipal League

**Jonathan Start**, Michigan Transportation Planning Association

**Rob Surber**, Michigan Department of Technology, Management  
and Budget (Non-Voting)

**Jennifer Tubbs**, Michigan Townships Association

**Brad Wieferich, P.E.**, Michigan Department of Transportation

**Todd White**, Michigan Department of Transportation

For added background on TAMC, its members and its related  
legislation, please visit the *About Us* section on the TAMC website at:

**[www.Michigan.gov/TAMC](http://www.Michigan.gov/TAMC)**

## To develop and support excellence in managing Michigan's transportation assets by:

- Advising the Legislature,  
the Michigan Infrastructure Council (MIC),  
State Transportation Commission,  
and transportation committees.
- Promote asset management principles.
- Provide tools and practices for road agencies.
- Collaborate and coordinate with the  
Water Asset Management Council (WAMC).

# INTRODUCTION

2019 was a very active year, from continued collection of road and bridge data, to new efforts related to developing training material for the 2018 legislation requiring larger road agencies to submit transportation asset management plans starting in 2020.

## Major takeaways from 2019:

### Transportation Asset Management Plans (TAMP) –

New legislation from 2018 drove TAMC efforts to provide new support and training for agencies to create their own TAMPs. (See 2019 Year in Review)

**Roads** – Poor condition pavements are still close to 40% for federal-aid roads and 50% for non-federal-aid roads. (See 2019 Road Condition)

**Investment Reporting** – Using data collected from the 617 road agencies, average costs for road and bridge projects are shown to assist in investment strategy discussions. (See Investment Reporting)

**Bridges** – A category of “Severe” has been added to show Bridges in Poor condition that are at a higher risk and risk being closed. (See 2019 Bridge Condition)

## 2018 - 2019 Federal-Aid Pavement Condition

Percent Lane Miles

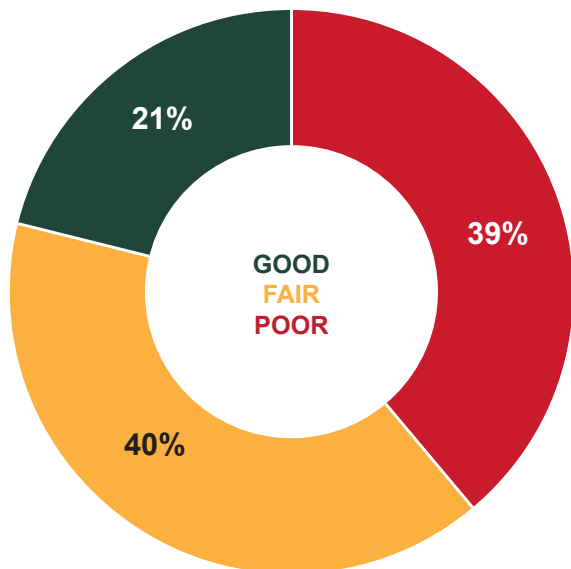

## 2019 Percent Severe Bridges

NBI 3 or Less

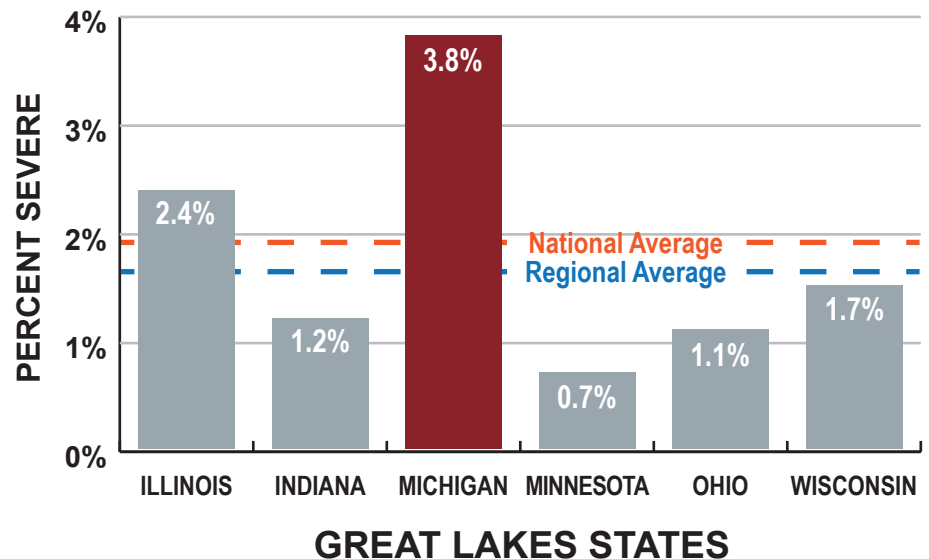

# TABLE OF CONTENTS



<b>2019 Year in Review</b> .....	<b>1</b>
TAMC Highlights and Accomplishments	
Transportation Asset Management Plans (TAMP)	
TAMC Website, Interactive Map and Dashboards	
<b>2019 Road Condition</b> .....	<b>9</b>
Condition Trend 2010-2019	
Paved Federal-Aid Condition	
Paved Non-Federal-Aid Condition	
Pavement Cycle of Life	
Pavement Condition Forecast	
<b>2019 Bridge Condition</b> .....	<b>15</b>
Condition Trend 2010-2019	
Comparing Bridge Conditions	
Trunkline Bridge Condition	
Local Agency Bridge Condition	
Bridge Cycle of Life	
Bridge Condition Forecast	
<b>Investment Reporting</b> .....	<b>23</b>
Investment Reporting Tool (IRT)	
Road Project Details	
Bridge Project Details	
Putting Pieces Together – Asset Management	
<b>Looking Into 2020</b> .....	<b>29</b>

# 2019 YEAR IN REVIEW



# TAMC Highlights and Accomplishments

In 2019, TAMC expanded both its partnerships and its core functions. TAMC's reporting tools and transparency efforts are some of the core functions that were enhanced over the year. TAMC also continues to provide valuable training and education opportunities to maintain quality data and collection standards. One of the biggest efforts was the result of changes to Act 51, which now requires Transportation Asset Management Plans for Michigan's larger road agencies.

## Culvert Pilot Receives APWA National Award

The efforts from 2018 TAMC Michigan Local Agency Culvert Inventory Pilot won the 2019 National American Public Works Association (APWA) Government Corporation Award. This pilot project involved TAMC, MTU/CTT and 49 local agencies. Their efforts located nearly 50,000 culverts statewide in a 13 week time frame.

## Conference Partnerships

In 2019, TAMC partnered with APWA for the second year in a row to host its Spring Conference in Gaylord, Michigan. The conference offered many opportunities for peer exchange and broaden the conference as a whole. The Fall Conference held in Marquette, Michigan offered a new opportunity to partner with the Michigan Infrastructure Council (MIC) and the Central Upper Peninsula Planning and Development Regional Commission (CUPPAD) at their Regional Asset Management Summit, which was held at the same venue.

To learn more on these conference including copies of all the presentations please visit:  
<https://ctt.mtu.edu/asset-management-resources>



Photos (top to bottom):  
Fall Conference Houghton County Flood Panel,  
APWA Award Winners, and Joint Spring Conference.



## Training, Work Program and Budget Overview

Figure 1 shows the numerous training and outreach efforts that are all part of the TAMC work program. TAMC FY2019 Budget is shown in Figure 2 with a breakdown of all program area expenses.

Note: Administrative staff is provided by MDOT and not included in the TAMC budget.

To learn more about the TAMC Work Program and Training Opportunities please visit: [www.Michigan.gov/TAMC/0,7308,7-356-82161---,00.html](http://www.Michigan.gov/TAMC/0,7308,7-356-82161---,00.html)

MTU/CTT - Training Programs		Training Events	Number of Participants
Asset Management Conferences		2	166
PASER Training		10 (and 5 webinars)	545
Asset Management for Elected Local Officials		5	110
Bridge Asset Management Workshop		3 (and 4 webinars)	36
Inventory Based Rating (IBR)		3	194
Paved Asset Management Plan Workshop		4	76
PA 325 Overview Webinar		2	83
AM Compliance Plan Webinar		4	91
<i>Figures provided by MTU's 2019 Training Report</i>		<b>Total: 33</b>	<b>1301</b>
DTMB/CSS - Training Programs		Training Events	Number of Participants
IRT Training		5 (and 3 webinars)	114

Figure 1  
Source: TAMC 2019

FY2019 Budget Overview	
Regional Program and Data Collection	\$1,116,400
Central Data Agency and Technology	\$380,000
Training and Educational Activities	\$350,000
Council Expenses	\$30,000
<b>Total:</b>	<b>\$1,876,400</b>

Figure 2  
Source: TAMC 2019



# Transportation Asset Management Plans (TAMP)

2019 included many discussions and efforts tied to PA 325 of 2018. This legislation requires local agencies with 100 or more miles of certified roads to submit a TAMP according to a schedule with the first round of plans due October 1, 2020.

The TAMP must include:

1. Asset Inventory
2. Performance Goals
3. Risk of Failure Analysis
4. Anticipated Revenue and Expenditures
5. Performance Outcomes
6. Coordination Clause
7. Proof of Adoption by Governing Body

TAMC has created resources and training opportunities to assist in this new process, including a template that utilizes an agency's previous data collection efforts and dashboard summaries. The IRT was also enhanced to help support this new requirement.

To learn more about this new requirement and available resources:

## TAMP FAQs

## TAMP Training and Asset Management Resources

The collage features three main components:

- TAMC Website Screenshot:** Shows the Michigan.gov TAMC Transportation Asset Management Council site. It includes a navigation menu with 'AWARDS', 'CONFERENCE', 'TRAINING', 'SUPPORT', 'ABOUT US', and 'MEETINGS'. The 'SUPPORT' section is expanded, showing 'LOCAL ASSET MANAGEMENT' with links to funding plans, templates, and training. The 'ASSET MANAGEMENT RESOURCES' section includes links to reports and studies.
- Michigan's Top 123 Road Agencies Map:** A map of Michigan with 123 agencies highlighted. It includes a legend for state trunkline, county, and city road mileage, and a table of agencies categorized by planning region and due date. The table lists agencies such as Emmet County, Benzie County, and Allegan County, along with their respective planning regions and due dates (October 1, 2020 or October 1, 2022).
- Center for Technology & Training:** A webpage with a search bar, a header image of people working, and sections for 'Training' (Upcoming Training, Past Training, Training By Request, Continuing Education Policy), 'Conferences' (County Engineers' Workshop, Contract Management Conference, Michigan Bridge Conference, Highway Maintenance Conference, Winter Operations Conference), and 'Project Pages' (Michigan LTAP). It also features 'Asset Management Resources' including templates and tools.

# TAMC Website, Interactive Map and Dashboards

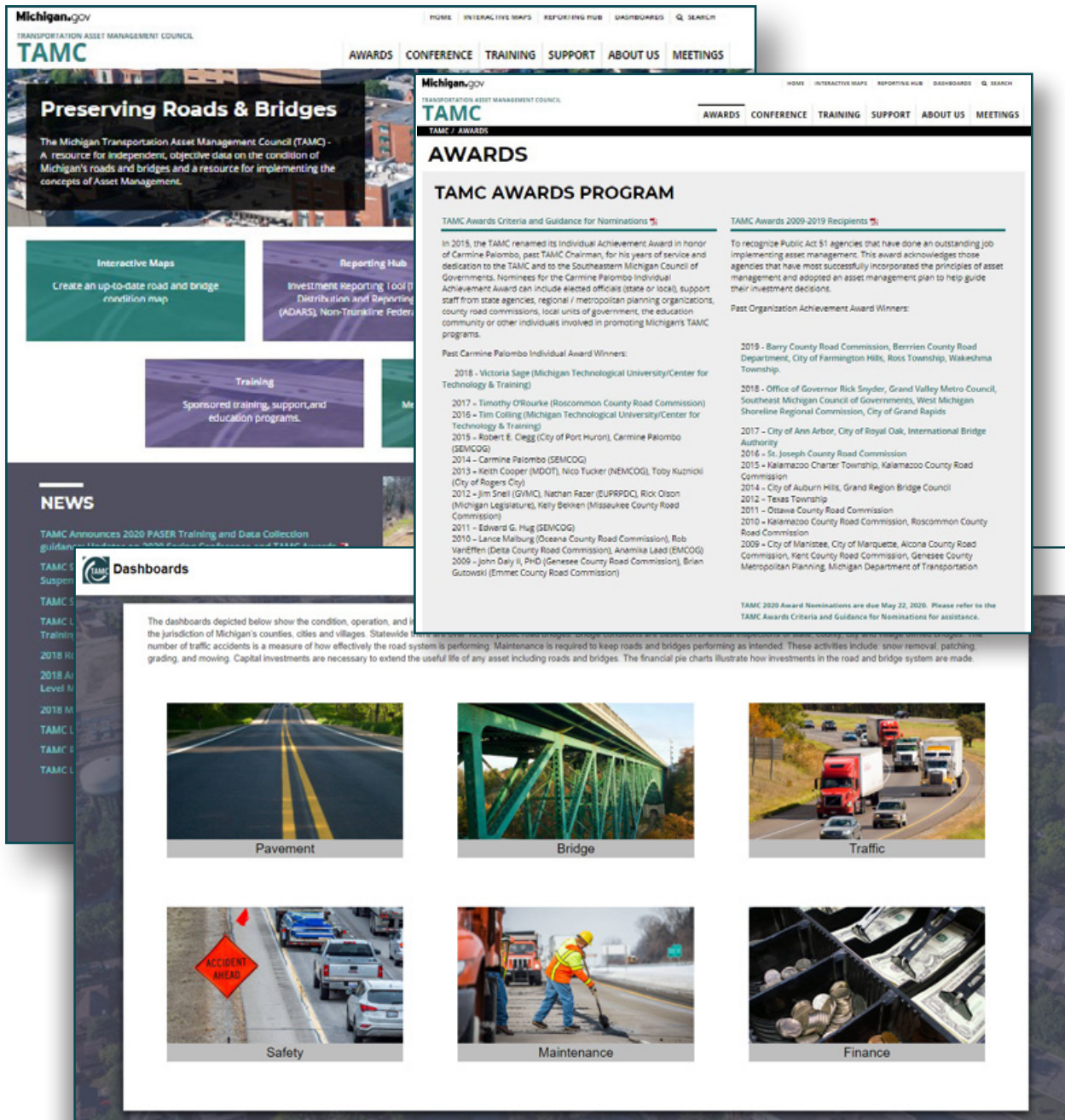

## Website

The TAMC website is the best resource for information on the condition of the statewide road and bridge system. TAMC provides multiple websites that serve as resources for anyone looking for information on the condition of the road and bridge system and other related efforts. The website provides access to data collected, training opportunities, upcoming meetings, and TAMC policies.

New areas include updates on the TAMC annual conferences and awards program for organizations and individuals striving to implement asset management.

The Support area provides additional resources and contact information for asset management, pilot projects, new legislative developments, and data research studies.

Please check out the TAMC website at [www.Michigan.gov/TAMC](http://www.Michigan.gov/TAMC) and sign up for the **Gov Delivery** to stay connected to any future updates.

## Interactive Map

TAMC maintains a public interactive map that has road and bridge conditions statewide and at a local level that are updated in May of each year. The interactive map is fully mobile and offers ease of use similar to Google maps. This is one of TAMC's main transparency efforts with numerous features to assist with seeing past trends and future coordination of infrastructure improvement. It can be used for outreach efforts, data access or planning presentations.

## Performance Measure Dashboards

The TAMC Dashboards provide another tool for the public to view numerous data sets in summary format and visual infographics. These fully support the mobile community and can be pulled up on a laptop, tablet or phone. These tools are free to be incorporated into agencies' websites to provide greater access and meet certain requirements rather than agencies having to create them on their own.

Information is available to see local or statewide data sets or customized by the type of road or bridge and planning organizations. The dashboards also provide financial, traffic and safety information. Click on each graphic for direct hyperlinks to the specific Performance Measure Dashboard.

**Michigan.gov TAMC Interactive Map**

Download PASER Ratings

Print Home

### Legislative Districts

Opacity

Off House Senate

Select a House District

068 Condition Summary

Year	Rating	Lane Miles	Percentage
2017 - 18	Good	53.7	7.4%
2017 - 18	Fair	191.9	26.5%
2017 - 18	Poor	478.2	66.1%
2016 - 17	Good	40	4.8%
2016 - 17	Fair	292.8	35.2%
2016 - 17	Poor	499	60%
2015 - 16	Good	57.5	6.2%
2015 - 16	Fair	299.7	32.1%
2015 - 16	Poor	576.2	61.7%
2014 - 15	Good	53.1	6.5%
2014 - 15	Fair	266.5	32.7%
2014 - 15	Poor	480.4	59.8%

**Michigan.gov TAMC Dashboards**

to extend the useful life of any asset including roads and bridges. The financial pie charts illustrate how investments in the road and bridge system are made.

Tabs at the top of this page lead to performance measures based on asset ownership and geography.

**Pavement**

### BRIDGE

Please choose a Bridge Report from the below options.

- Bridge Conditions
- Trend Analysis
- Bridge Forecast
- Bridge Comparison

## Pavement Condition and Comparison Dashboards

These two dashboards are based on PASER ratings for all state trunklines as well as roads under the jurisdiction of Michigan's counties, cities and villages. These dashboards illustrate past and present conditions and future forecast trends. The Pavement Comparison Dashboard provides the user with the ability to compare up to eight road owning agencies current road conditions at one time.

## Bridge Condition and Comparison Dashboards

Bridge conditions are based on bi-annual inspections of over 11,000 state, county, city and village owned bridges. These two dashboards illustrate bridge conditions and trends and provides the user with the ability to compare system performance for up to eight bridge-owning agencies at one time.

## Traffic Dashboard

Traffic volumes are a measure of both road use and how effectively the road system is performing. This dashboard shows estimated annual miles of travel on Michigan's roads as well as a comparison of the relative sizes (in centerline miles) of portions of Michigan's road network.

## Safety Dashboard

The rate of crashes (fatalities, serious injuries) is a measure of how effectively the road system is performing in safety. This dashboard was designed using federal performance metrics.

## Maintenance Dashboard

This dashboard provides a county by county comparison of winter maintenance expenses that are necessary to keep roads and bridges performing during winter maintenance operations.

## Finance - Revenues and Expenditures Dashboards

These dashboards illustrate how Michigan's road agencies are investing in the roads and bridges they own, along with the revenues received by each agency.

Act 51 requires that each county road agency maintain a website that includes a financial performance dashboard with information on revenues, expenditures and unfunded liabilities. Adding a link to the TAMC website meets those requirements.





# 2019 ROAD CONDITION



Beginning in 2003, MDOT, county, regional, and metropolitan planning agencies joined together to determine the condition of Michigan's paved federal-aid roads, which account for about 1/3 of Michigan roads and carries over 95% of the traffic. Under the direction of TAMC, Pavement Surface Evaluation and Rating (PASER) was the measure chosen to identify the condition of pavements. Road professionals evaluate surface condition on a 1-10 scale, which is then consolidated into three categories: good, fair, and poor.

PASER Condition Ratings		
8-10	Good Condition	Routine maintenance candidate.
5-7	Fair Condition	Preventative maintenance or rehabilitation candidate.
1-4	Poor Condition	Rehabilitation or reconstruction candidate.

As shown in Figure 3, in 2019, 39% of all paved federal-aid roads or 33,000 lane miles are in poor condition. Given the current rate of road deterioration, the proportion of roads in poor condition will remain close to 40% until significant increases in investment are made.

## Paved Federal-Aid Road Condition 2010-2019

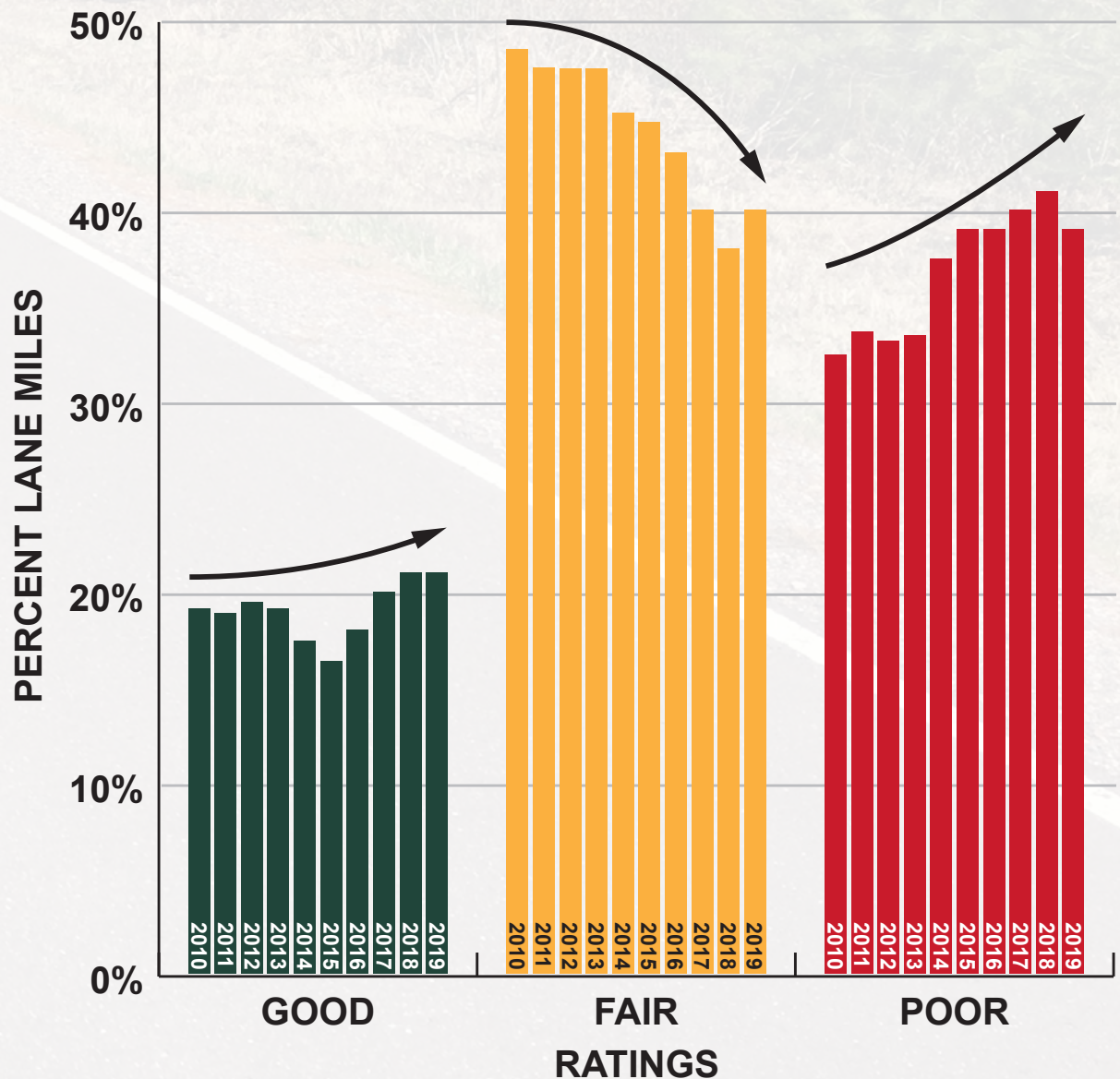

Figure 3

Source: 2010-2019 PASER Data Collection

# 2018 - 2019 Federal-Aid Pavement Condition

Percent Lane Miles

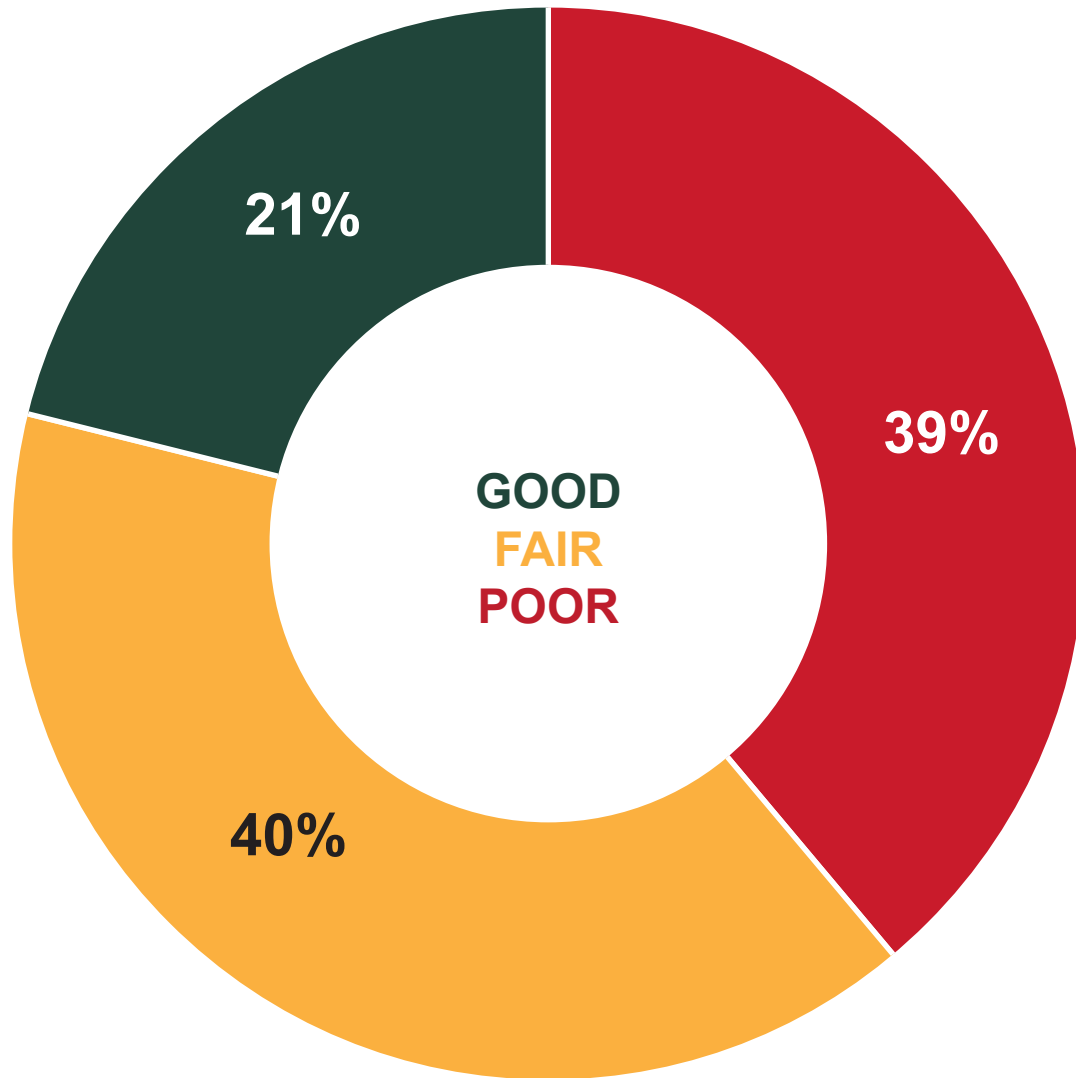

Figure 4

Source: 2018-2019 PASER Data Collection

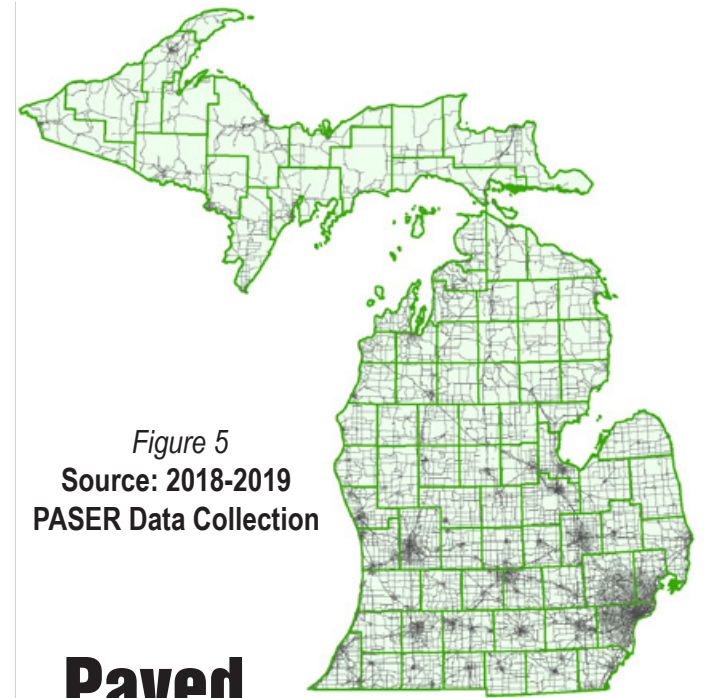

Figure 5

Source: 2018-2019  
PASER Data Collection

## Paved Federal-Aid Roads

Road agencies report on the condition of all paved federal-aid roads over the course of two years. Figure 5 is a map showing roads rated in 2018 and 2019. About 60% of the 88,000 lane miles were collected in 2019 and the remaining 40% were collected in 2018.

Figure 4 shows a composite of those lane miles. 39% of Michigan's lane miles are now in poor condition. In 2019, close to 900 lane miles (2 percent) transitioned from poor to a fair condition. However, the majority of these improvements can be attributed to short term fixes rather than long term solutions.



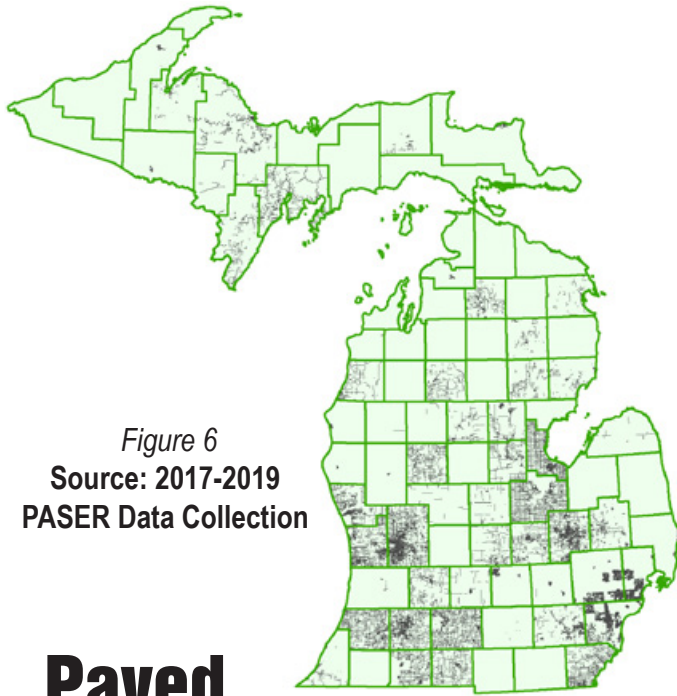

Figure 6  
Source: 2017-2019  
PASER Data Collection

## Paved Non-Federal-Aid Roads

There are over 165,000 lane miles of non-federal-aid roads in Michigan. The federal government classifies these roads as being “Local Roads.” Each year, many road agencies choose to rate some or all their paved non-federal-aid roads.

The ratings are typically done on a 3-year cycle. Figure 6 shows from 2017-2019, close to 300 agencies reported ratings on 45,329 miles. Over 50% of these roads were found to be in poor condition as seen in Figure 7. Agencies use ratings on both federal-aid and non-federal-aid roads to help manage their road network.

## 2017 - 2019 Non-Federal-Aid Pavement Condition

Percent Lane Miles

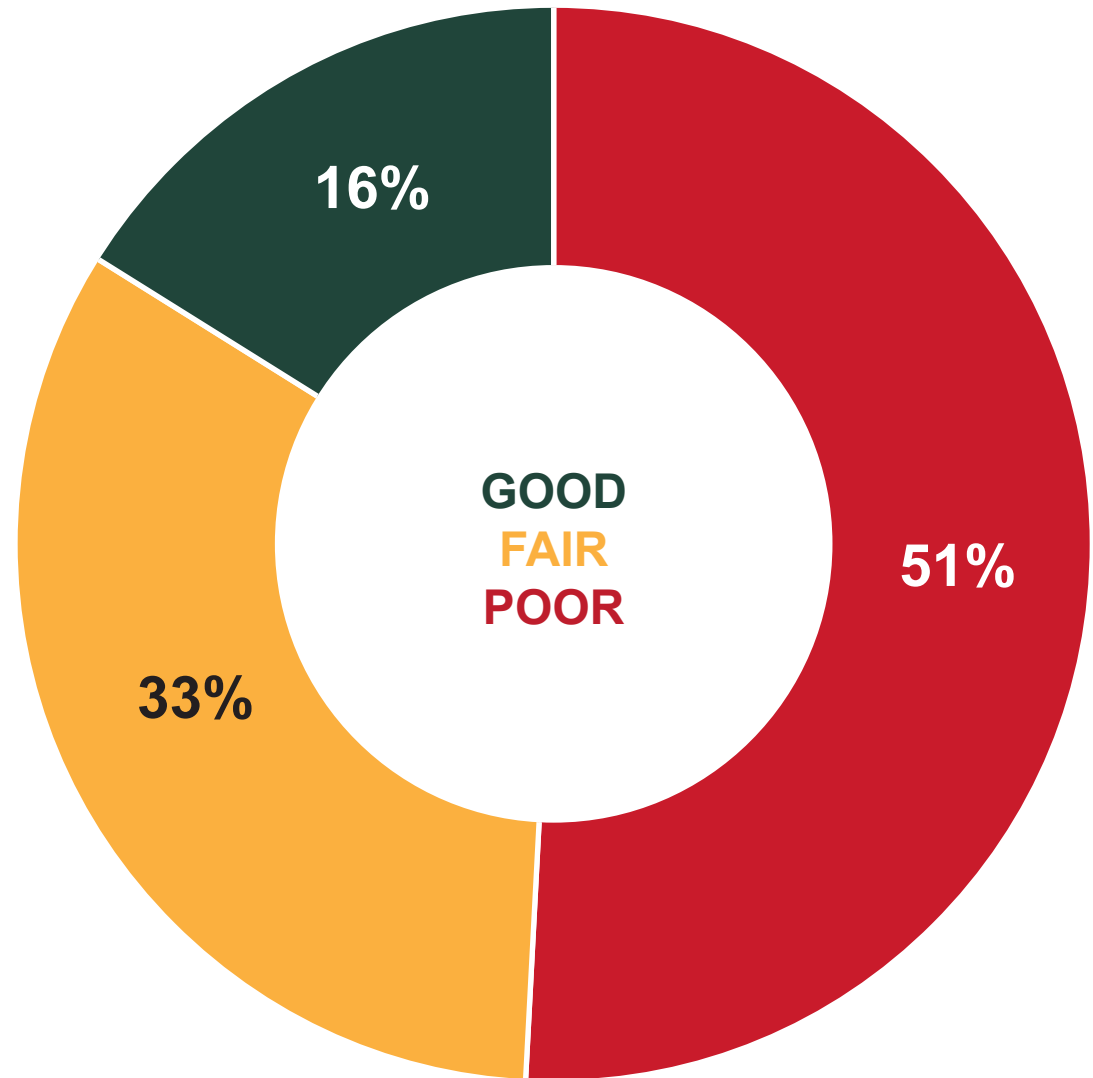

Figure 7  
Source: 2017-2019 PASER Data Collection

# Pavement Cycle of Life

Federal-Aid Network 2016-2019

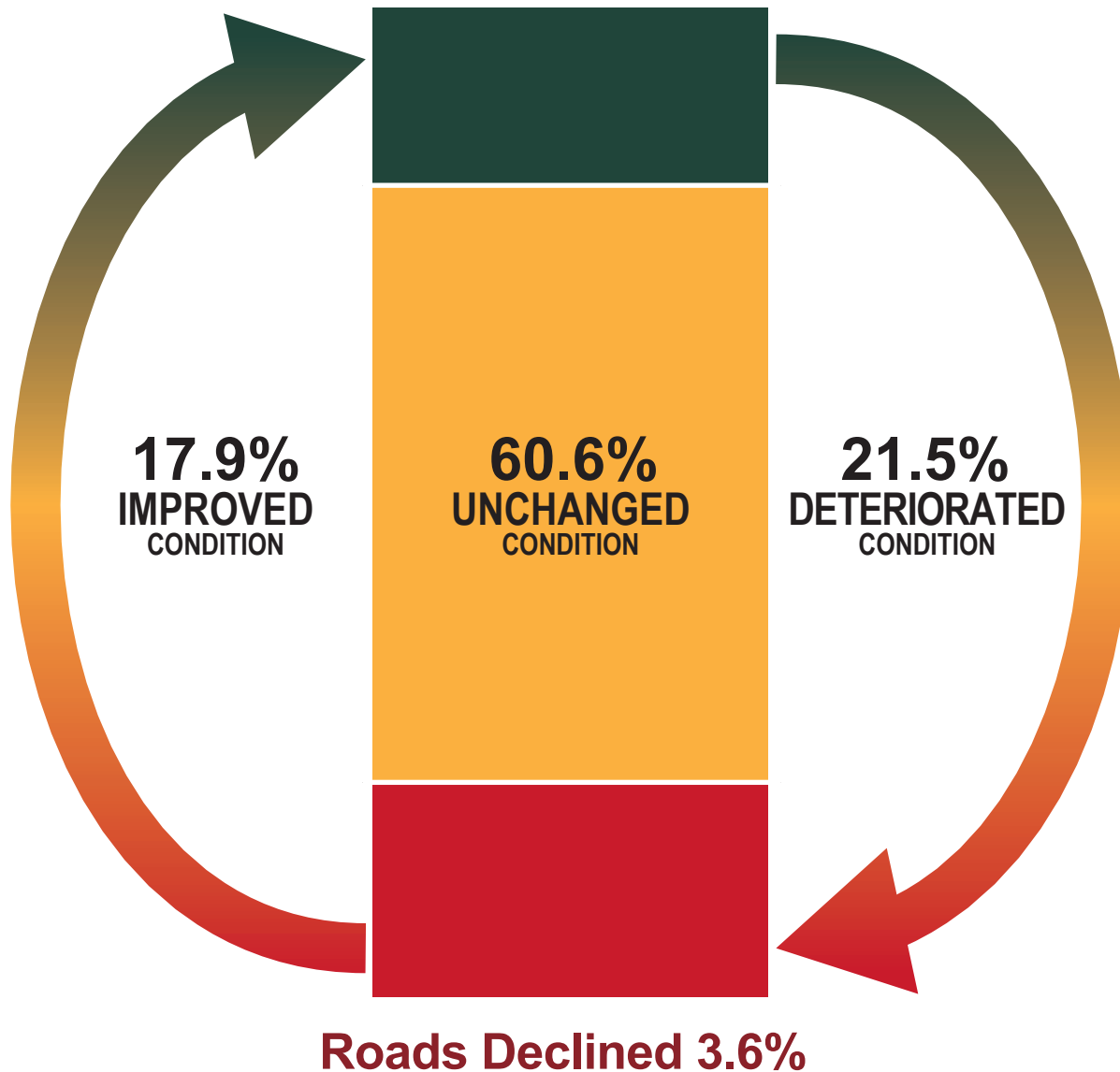

Figure 8

Source: 2016-2019 PASER Data Collection

# Pavement Cycle of Life

Every year, TAMC analysts examine the pavement data to determine the extent to which roads are improved or deteriorate over a 4-year span. This effort tracks how roads change from between the good, fair, and poor ratings and is referenced as the Pavement Cycle of Life.

Figure 8 shows 3.6% more pavements have deteriorated than have been improved between 2016-2019. This continues a trend since 2005.

In simplified terms, the number of potholes continues to outpace the ability to fill them.



# Pavement Condition Forecast

Working from current pavement condition (PASER), road deterioration rates, project costs, expected inflation, revenues and fix strategies, the Pavement Condition Forecasting System (PCFS) estimates the future condition of pavements.

Figure 9 indicates that in the next 12 years there will be an increase in the percent of roads in good condition and decrease in the percent of roads in fair condition.

These changes are attributed to:

- Increased Investment – An additional \$575M on the local system over the next 10 years from the projected growth of the MTF distribution to local agencies.
- Investment Strategy – Local road agencies are investing more in CPM and rehabilitation projects which helps improve roads in fair condition to good condition, and prevents more roads falling into poor condition.

However, Figure 9 also indicates without additional investment, the percent of roads in poor condition will remain around 40% for the foreseeable future.

# Pavement Condition Forecast

2021-2031

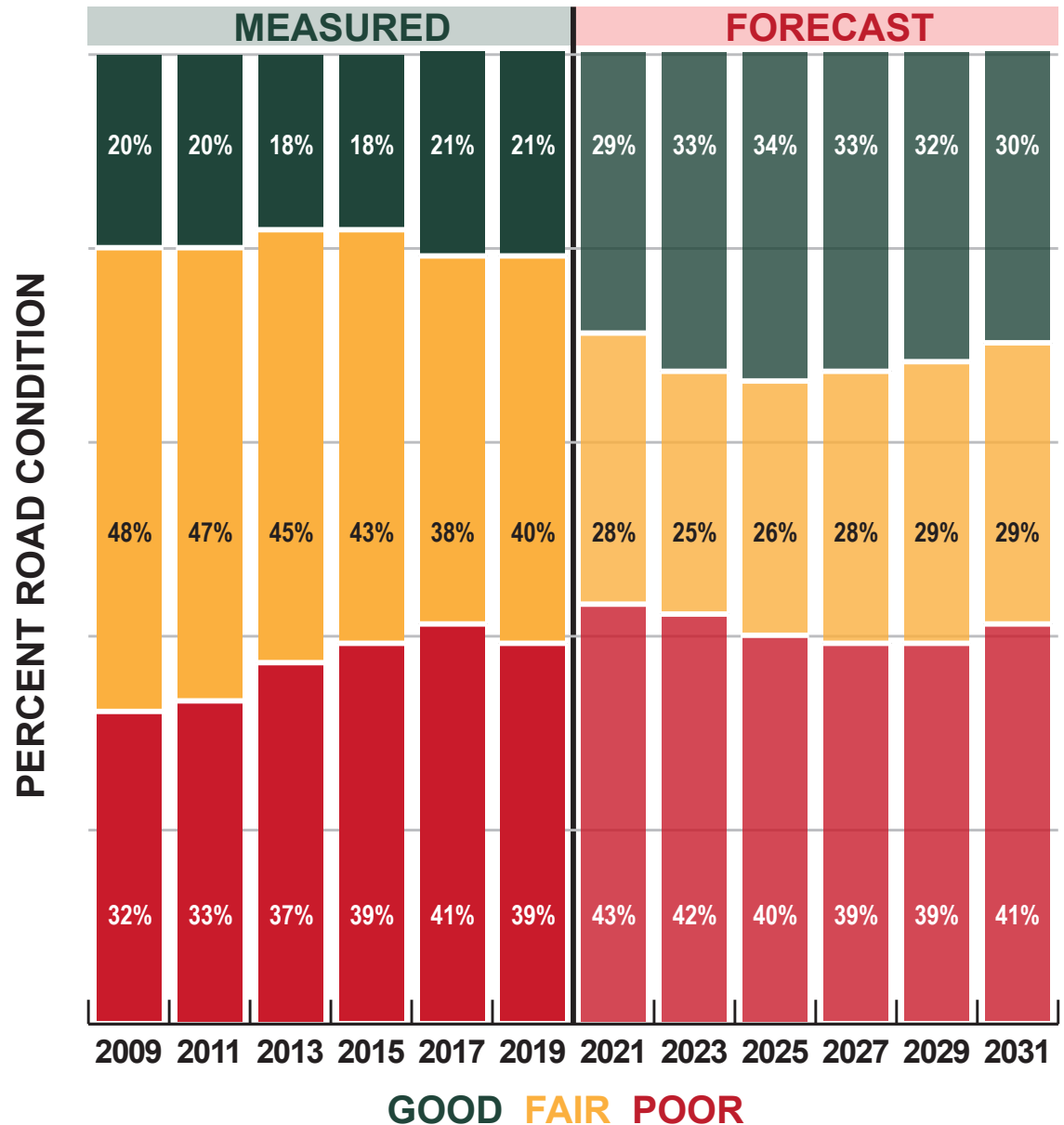

Figure 9

Source: 2020 TAMC



# 2019 BRIDGE CONDITION



The National Bridge Inspection Standards (NBIS) define a bridge as a structure carrying traffic with a span greater than 20 feet. Condition ratings are based on a 0-9 scale and assigned for each culvert, or the deck, superstructure, and substructure of each bridge. These ratings are recorded in the National Bridge Inventory (NBI) database..

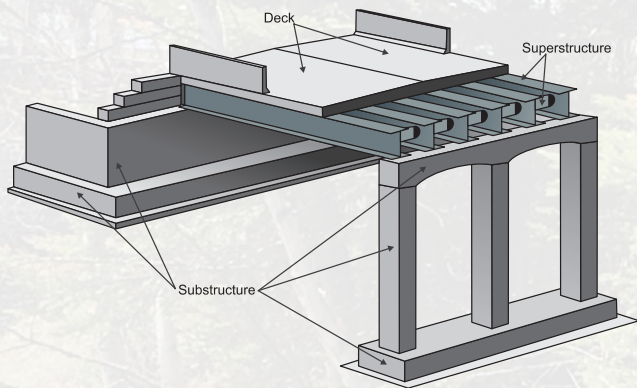

As shown in Figure 10, in 2019 over 1200 bridges or 11% of NBI structures are in poor condition. Given the current rate of bridge deterioration, bridges in poor condition will continue to increase until significant increases in investment are made.

# Statewide Bridge Condition

2010-2019

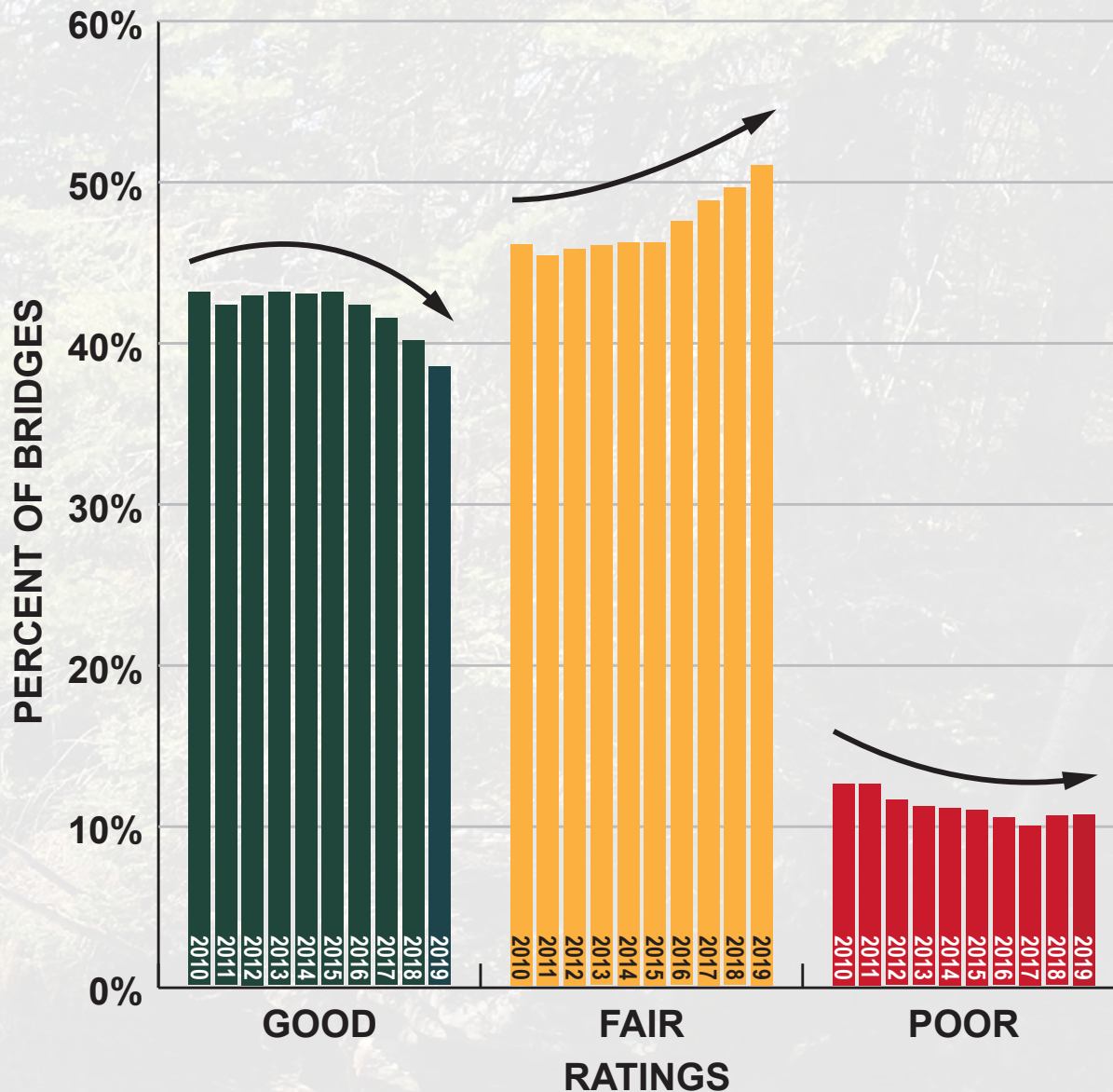

Figure 10

Source: 2010-2019 Michigan Bridge Inventory



# Comparing Bridge Condition

Michigan lags behind its neighboring Great Lakes States in terms of bridge condition. As seen in Figure 11, Michigan has the highest percentage of poor bridges in the Great Lakes Region, and also has significantly more poor bridges than the national average. More concerning, when measuring the bridges in Severe Condition, or those requiring additional monitoring, immediate action, or at risk of closure, Michigan has double the percentage of bridges with NBI ratings of 3 or less.

NBI Condition Ratings		
7-9	Good Condition	Routine maintenance candidate.
5-6	Fair Condition	Preventative maintenance or minor rehabilitation candidate.
4	Poor Condition	Major rehabilitation or replacement candidate.
2-3	Severe Condition	Emergency repair, high priority major rehabilitation or replacement candidate. Unless closely monitored it may be necessary to close until corrective action can be taken.
0-1	Imminent Failure or Failed	Major rehabilitation or replacement candidate. Bridge is closed to traffic.

## 2019 Percent Poor Bridges

NBI 4 or Less

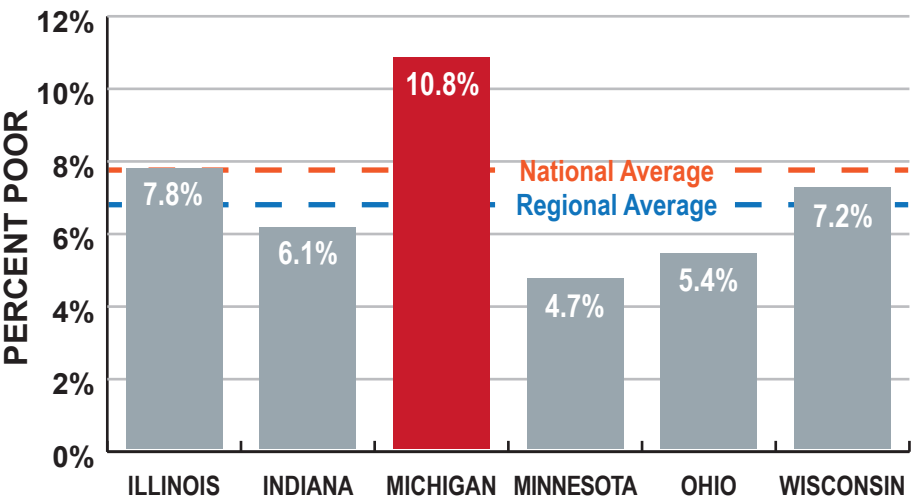

GREAT LAKES STATES

## 2019 Percent Severe Bridges

NBI 3 or Less

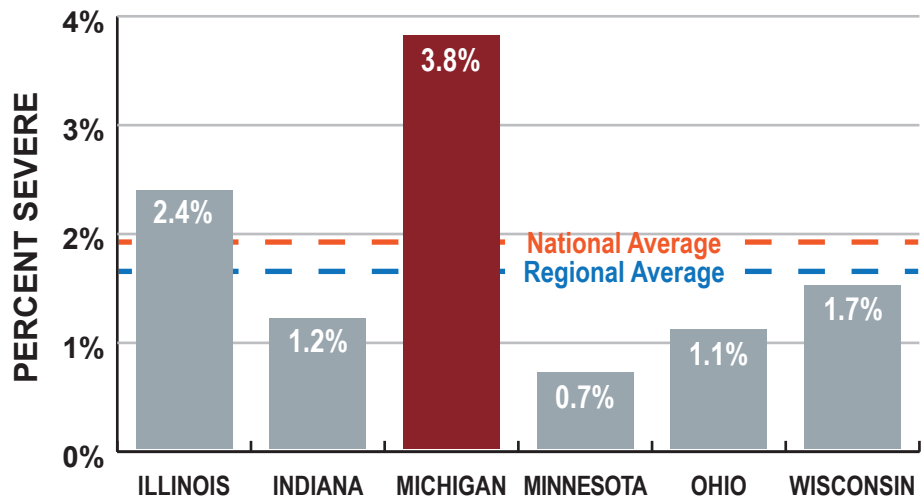

GREAT LAKES STATES

Figure 11

Source: 2019 National Bridge Inventory

# Trunkline Bridges

Unlike roads, all bridges are considered federal-aid eligible. Figure 12 shows that MDOT has around 6% of its bridges in poor or severe condition and 67% of bridges are in fair condition. This large population of bridges in fair condition represents the previous investments in preservation. Until recently, MDOT has been able to maintain the number of bridges in fair condition before they reach the poor category, while increasing the number of bridges in good and fair condition. An aging infrastructure and rising costs along with stagnant funding or not enough existing revenue or lack of new revenue to maintain our aging bridges, have reversed some of that progress.

The number of bridges in fair condition has increased, and since 2017 the number of bridges in poor condition has increased as preservation needs exceed available revenues. Maintaining or improving the bridges rated in good or fair condition is imperative to prevent the number of bridges in the poor category from increasing further.



# 2019 Trunkline Bridge Condition

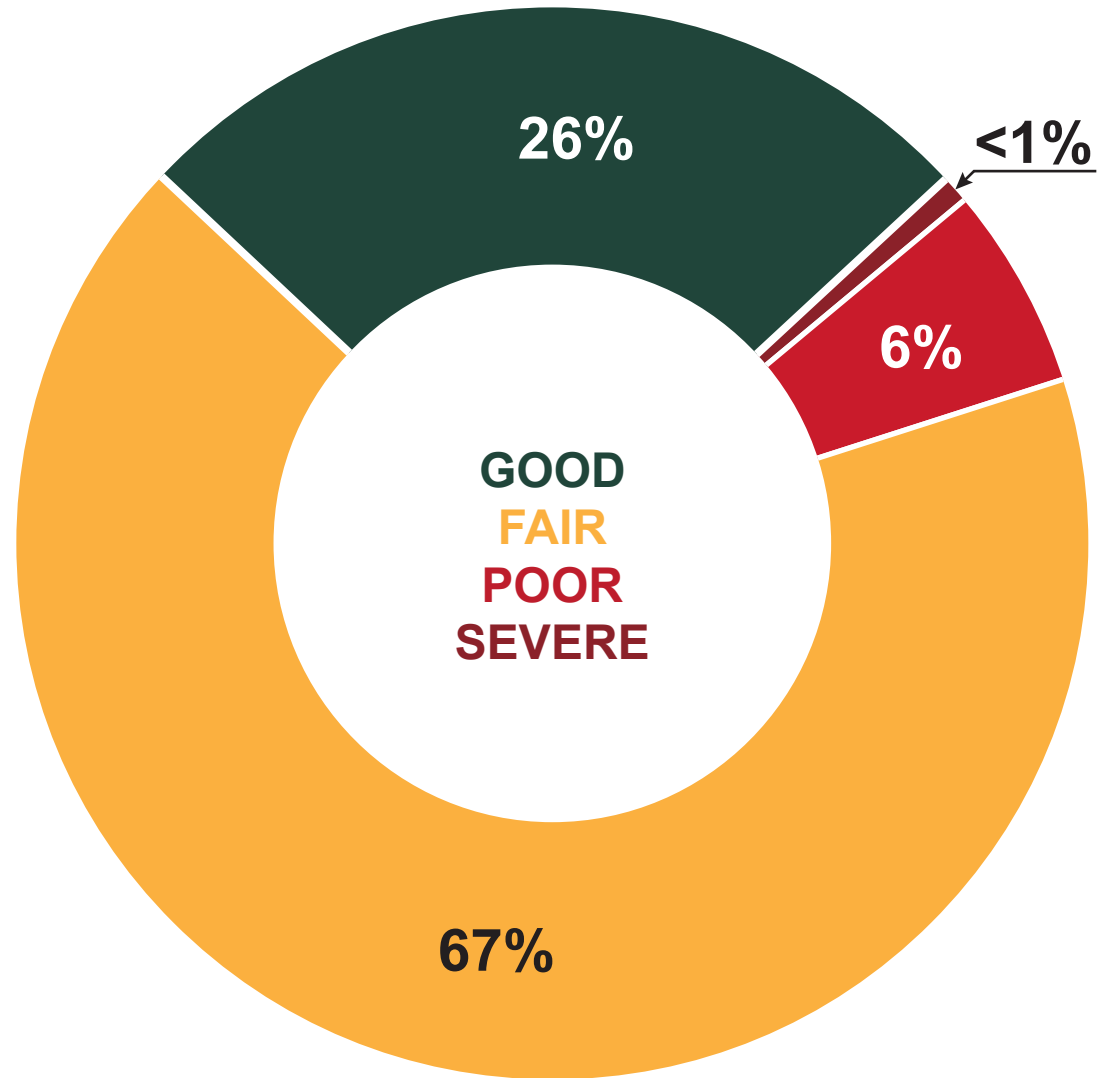

Figure 12  
Source: 2019 National Bridge Inventory

# 2019 Local Agency Bridge Condition

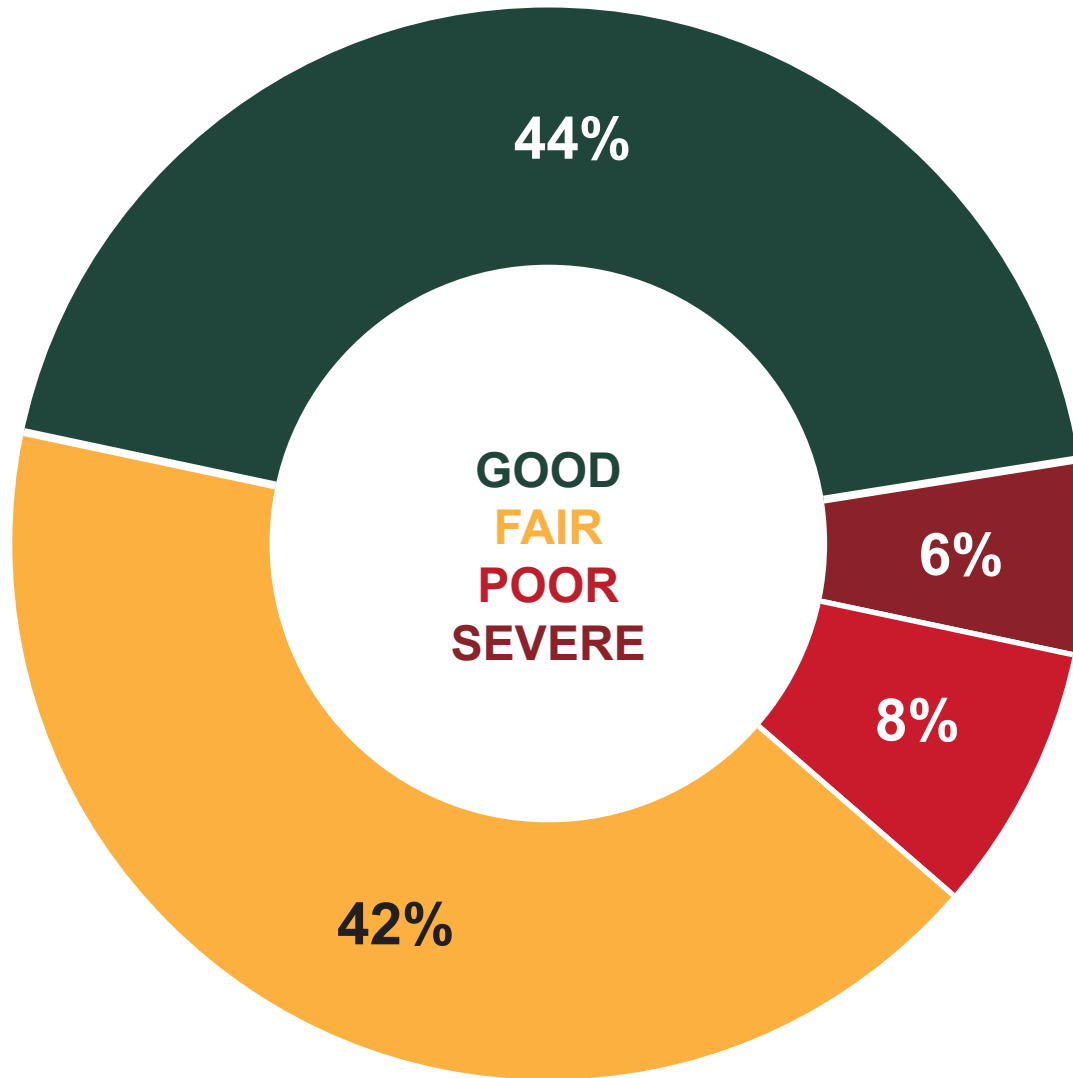

Figure 13

Source: 2019 National Bridge Inventory

# Local Agency Bridges

Figure 13 show that local agencies are managing both a larger percentage of good bridges, while also managing a larger percentage of poor and severe bridges. While many local agencies are working to embrace preservation strategies but are prevented by the overwhelming need of the bridges in the worst conditions.

A bridge in poor condition is a candidate for major rehabilitation or replacement. When the bridge no longer has the strength to bear the loads for which it was designed, the bridge must be posted for lower loads in order to maintain safety. A bridge in severe condition often needs expensive emergency repairs, temporary supports, or shoulder closures. Ultimately, the inability to obtain funding will result in a safety risk to the public and the bridge must be closed.

At the end of 2019, 58 local agency bridges were closed due to their condition.





# Bridge Cycle of Life

Every year, analysts examine the bridge data to determine the extent to which bridges are improved or deteriorate over a 4-year span. This effort tracks how bridges change from between the good, fair, and poor ratings and is referenced as the Bridge Cycle of Life.

Figure 14 shows over 7.6% more bridges have deteriorated than have been improved between 2016-2019.

In simplified terms, the deteriorating bridges outpaces the ability to repair or replace them.



# Bridge Cycle of Life

All Bridges 2016-2019

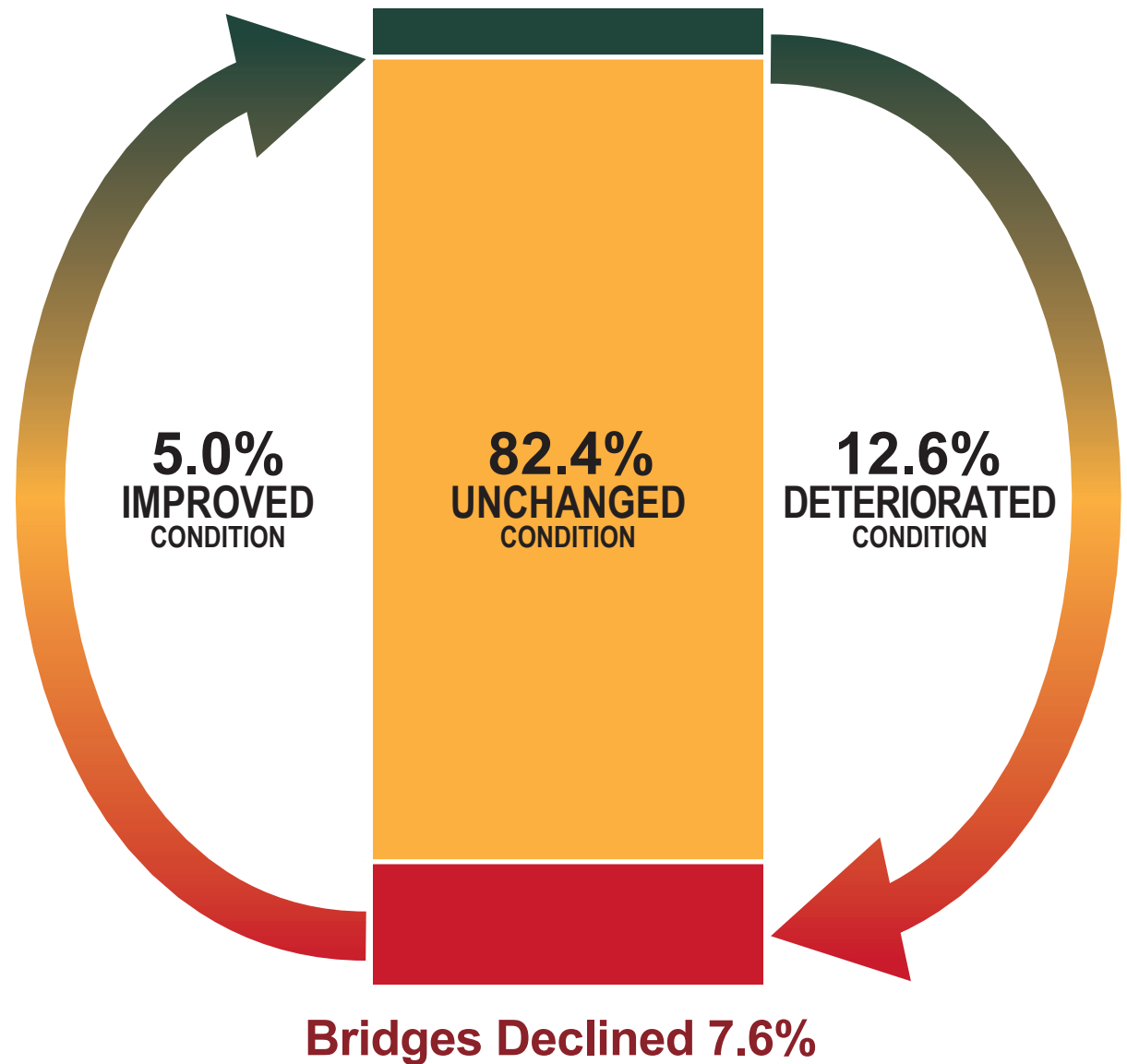

Figure 14

Source: 2016-2019 Michigan Bridge Inventory

# Bridge Condition Forecast

2021-2031

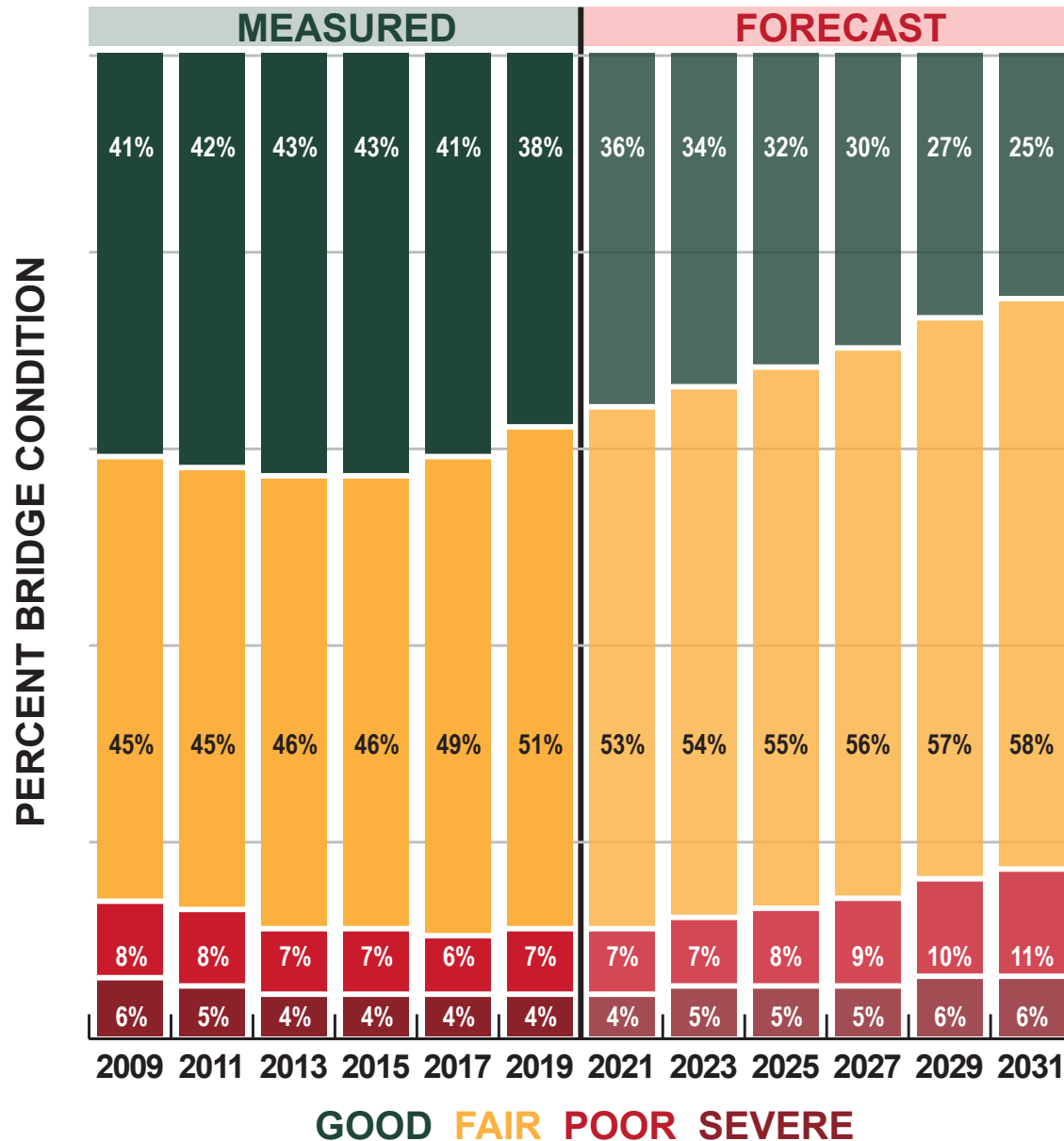

Figure 15

Source: 2020 TAMC

# Bridge Condition Forecast

Working from current bridge condition information (NBI), bridge deterioration rate, project costs, expected inflation, and fix strategies, the Bridge Condition Forecasting System (BCFS) estimates future condition of bridges. Figure 15 indicates the combined overall bridge condition of all Michigan's bridges is expected to continue to decline after 2019.

While additional funding has been approved for the state level trunkline bridges, no new funds were earmarked specifically for local bridge programs. Therefore, this forecast assumes no additional spending on bridges beyond those funds already designated for that purpose.

This forecast also includes the severe condition category that continues to rise. This indicates additional bridges will be at high risk for public safety and lead to more emergency repairs and closures without additional investment for bridge programs.

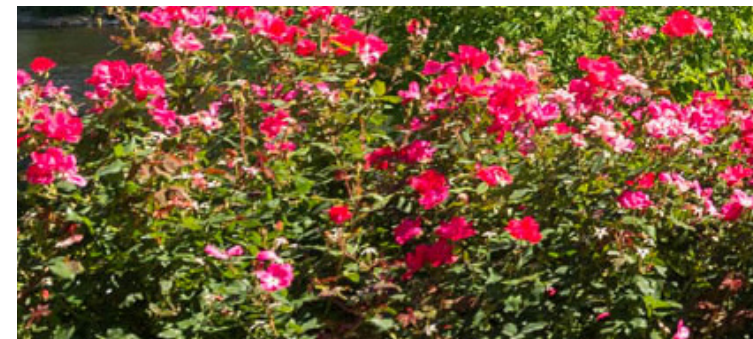



# INVESTMENT REPORTING



# Investment Reporting Tool (IRT)

The IRT was developed to allow all Michigan road agencies to satisfy the requirements of Act 51. The basic requirements are reporting road and bridge projects they have completed and projects that are planned in the next three years.

What follows in this section are added details about the tool along with summaries of the IRT data and average costs. This information is being used to help refine forecasting efforts and investigate statewide investment strategies.

With the IRT, a road agency can manage its road and bridge assets with customized maps, data exports and a variety of summary reports. Some of the new features and enhancements include:

- Areas for warranties and asset management plans
- Project reporting options with Roadsoft software
- PASER submission and review for planning agencies
- Free training statewide and online webinars
- Help desk and YouTube videos

Additionally, the interactive map in the IRT can show project information for meeting presentations and public outreach. TAMC welcomes feedback to improve the tool toward greater data quality, transparency and collaboration.

The screenshot shows the Michigan.gov Investment Reporting Tool (IRT) interface. The main header includes the Michigan.gov logo and navigation links for 'Projects', '+ Add', 'Map', and 'Reports'. The user is logged in as 'Dave Jennett - City of Tawas City'. The main content area displays project details for '6th Ave' in 2017, with a 'Poor' condition and a '2' in a red box. Below this, there are sections for 'Road Projects' and 'Bridge Projects', each with a table of project details including Year, Project ID/Name, Classification, and Improvement Type. A search bar and filter options are visible at the bottom of the interface.

The screenshot shows the Michigan.gov Investment Reporting Tool (IRT) interface for the City of Tawas City. The main header includes the Michigan.gov logo and navigation links for 'Projects', '+ Add', 'Map', and 'Reports'. The user is logged in as 'Dave Jennett - City of Tawas City'. The main content area displays a summary dashboard with the following data:

City of Tawas City	28	21
Total Road Miles: 17.733	Entered Projects Fiscal Years 2017 - 2019	Planned Projects Fiscal Years 2020 - 2022
Total Bridges: 4		

Below the dashboard, there is a table with columns for 'Road', 'Bridge', and 'Asset Management'. The table shows the status of projects for each category.

Road	Bridge	Asset Management
Not Completed	Not Completed	Not Completed
Completed	Completed	Completed
Completed	Completed	Completed



# Road Project Details

As seen in Figure 16, 2016-2019 road projects submitted to the IRT total roughly \$5 billion dollars of total investment. A complete 2019 data set will be available fall of 2020 as reporting is based on each agency’s Fiscal Year.

Figure 17 is a listing of average costs compiled from 2016-2019 IRT reporting of road projects. For analysis and forecasting efforts it’s important to recognize costs to implement different type of projects or “mix of fixes.” For modeling purposes “major highways” are NFC 1-2 and “minor roads” are NFC 3-7.

On page 26, Figure 18 and Figure 19 stress several key points:

- Significant cost increase when CPM is no longer viable
- Difference in a highway versus a two-lane road
- The need to maintain Good and Fair condition roads to prevent the deterioration into Poor condition

With 40% of roads statewide in poor condition, the vast amount of pavement work and required rehabilitation and reconstruction, stress the need for new investment in the billions.

Road IRT Project Summaries			
Year	Projects Reported	Total Cost	Total Lane Miles
2016	4,560	\$1.45 Billion	12,043
2017	4,681	\$1.06 Billion	16,531
2018	5,462	\$1.11 Billion	18,672
2019	2752	\$1.34 Billion	10,189
<b>Total:</b>	<b>17,455</b>	<b>\$4.96 Billion</b>	<b>57,435</b>

Figure 16

Source: 2016-2019 TAMC

Average Cost for Different Road Work	Cost Per Lane Mile	
	Minor Road	Major Highway
Type of Projects		
Light Capital Preventive Maintenance	\$10,754	\$33,687
Heavy Capital Preventive Maintenance	\$46,251	\$89,696
Rehabilitation	\$191,058	\$531,000
Reconstruction	\$661,395	\$1,701,000

Figure 17

Source: 2016-2019 TAMC



## Fix Options For Good and Fair Roads

\$10K - \$90K Cost Per Lane Mile:  
Capital Preventive Maintenance (CPM)

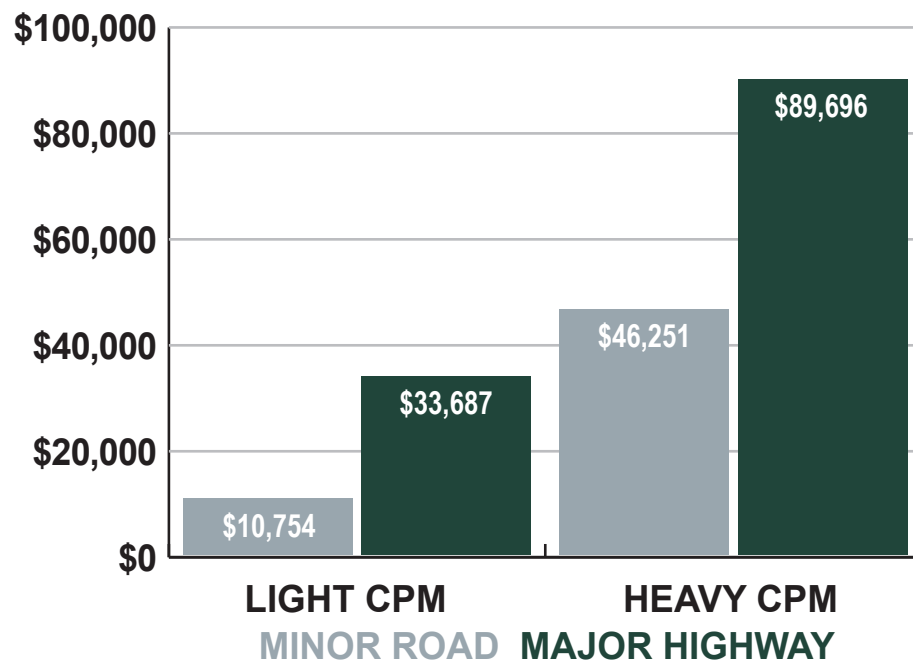

Figure 18  
Source: 2016-2019 TAMC

## Fix Options Required For Poor Roads

\$190K - \$1.7M Cost Per Lane Mile:  
Rehabilitation and Reconstruction

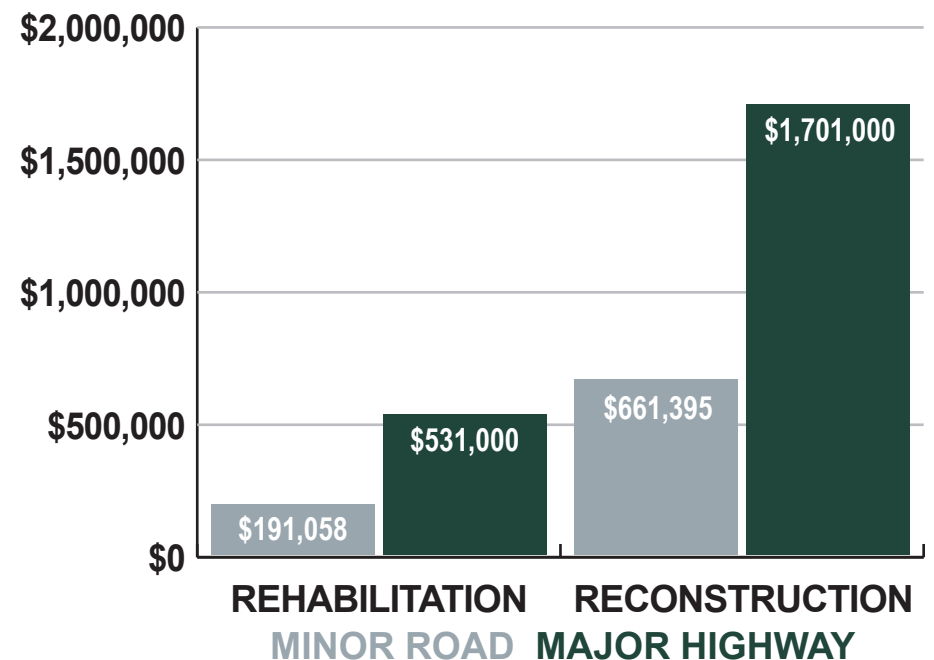

Figure 19  
Source: 2016-2019 TAMC



## Bridge Project Details

Figure 20 indicates that investment in bridge projects vary from year to year with a range of \$160M to \$375M. Roughly \$1.12 billion was reported from 2016-2019.

Of Michigan's 617 road agencies, 352 own and maintain bridges. Of Michigan's 11,000 bridges, approximately half are owned by MDOT and half by local road agencies. Bridges can vary substantially in their length, deck area and other factors. However, replacing a bridge often greatly impacts the local economy as well as emergency services regardless of agency size.

Figure 21 shows a sample of IRT reported replacement bridge projects. An average "small bridge" could be a 60 foot one span crossing with 2 lanes of traffic where a "large bridge" may have additional lanes and spans to cross further distances and carry heavier commercial traffic.

Sustained funding and preventive maintenance are even more critical for a bridge. The cost to replace a bridge for a small road agency may be more expensive than maintaining all the roads they own.

Note: The Rouge River Bridge, Zilwaukee Bridge and other large bridges are not included in statewide totals, since the high cost of this type of project would significantly shift totals and averages.

Bridge IRT Project Summaries			
Year	Agencies Reporting Bridge Projects	Total IRT Reported Cost	Projects Reported
2016	64	\$330 Million	293
2017	61	\$160 Million	244
2018	53	\$375 Million	351
2019	41	\$255 Million	352
<b>Total:</b>		<b>\$1.12 Billion</b>	<b>1240</b>

Figure 20

Source: 2016-2019 TAMC

## Sample Replacement Costs

Small and Large Bridges

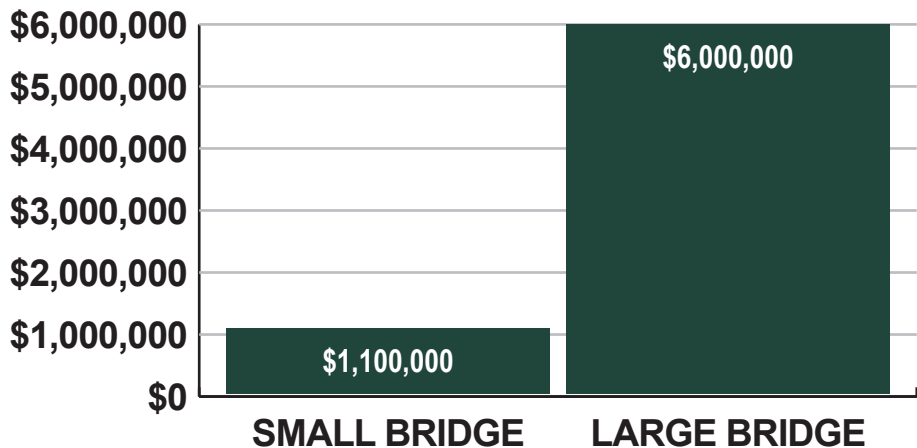

Figure 21

Source: 2016-2019 TAMC



# Putting Pieces Together - Asset Management

Critical pieces of information in the asset management toolbox is the timing of preventive fixes being applied prior to facing significant costs of roads or bridges reconstruction once they deteriorate into poor condition.

Figure 22 is a table referred to as “Saving the 5’s.” Maintaining roads that are in Fair condition are critical in managing a system. As seen in the chart close to 80% of road projects applied to the “5’s” are still Preventive Maintenance projects.

Figure 23 is a generalized chart that shows where these transitions occur over time and types of improvements to bring a road back into good condition. Keep in mind, the cost of maintenance and rehabilitation can be in the 4-6 figures of investment. Roads and bridges both need these efforts before it’s too late and they fall into the poor and reconstruction in the 6-7 figures investment is required.

In general terms, Michigan must use asset management best practices to save the roads and bridges in Good and Fair condition. However, as seen in the previous road and bridge project and condition summaries – substantial investment in the billions of dollars is needed to allow for further mix of fixes to address Michigan’s aging and critical infrastructure. TAMC is utilizing all of these tools to build a statewide investment strategy.



Saving The 5’s	
Breakdown of Road Projects Applied to Roads With a PASER Rating of 5 (Fair Condition)	
Light Capital Preventive Maintenance	43%
Heavy Capital Preventive Maintenance	35%
Rehabilitation	18%
Reconstruction	4%

Figure 22  
Source: 2020 TAMC



Figure 23  
Source: 2020 TAMC

# LOOKING INTO 2020





## Continuing the Culverts

2020 looks to continue the discussions on the critical assets of culverts. From the 2018 Culvert Inventory Pilot, TAMC is investigating best practices and lessons learned. TAMC is also continuing a culvert focus group that includes the WAMC, MDOT, and EGLE along with local agencies and universities to determine what steps are next in this important effort.

## Remembering the TAMP

October 1, 2020 is a big date for 40 road agencies across the state, as the first round of the top 123 road agencies are required to submit their own TAMP. It is important that agencies stay aware of this as it can be a large effort. TAMC is here to support in any way it can with an extensive list of contacts and resources, including a template plan that uses local data to create a draft that gets a road agency most of the way there.

## Investigating the IBR

In 2018, gravel roads IBR was introduced. After two years of data collection similar to PASER, this valuable asset of Michigan's road network is being considered. This new rating system provides added tools to manage this important and often missed element of Michigan's road infrastructure.

## TAMC Conferences

With the ever-increasing interest in asset management, TAMC continues to support conferences that showcase Michigan's road agency efforts, national trends and international speakers as well. Asset management is all about collaboration and these conferences promote the spirit of teamwork by sharing experiences and providing means to network with peers. TAMC continues to offer these as a means to unite Michigan with asset management.



## Improving the Technology

TAMC continues to stay on pace with new technology as it advances and incorporates feedback from agencies and individuals that use TAMC's many tools and resources. New items scheduled for 2020 include TAMC's Interactive Map showing road and bridge conditions by House and Senate legislative districts, along with new integration with the STIP that will assist IRT users in entering planned projects.

## Looking at Strategies

One of TAMC's long-term goals has been to try to develop statewide investment strategies for Michigan's road and bridges. This year, TAMC is using historical condition and IRT projects reported by all road and bridge owning agencies along with other data sources to refine forecasting scenarios and propose potential investment strategy options. Look for TAMC to publish a document this year which will describe these strategies and the asset management principles behind them.

# **“All public roads in Michigan will be managed using the principles of asset management”**

- Public Act (PA) 499 of 2002 created the Michigan TAMC

**[Michigan.gov/TAMC](http://Michigan.gov/TAMC)**

