

John C. Peterson, Director
Contract Performance and Administration
Wholesale Markets



Wholesale Markets
600 Hidden Ridge, HQE03D52
P.O. Box 152092
Irving, TX 75038

Phone 972-718-5988
Fax 972-719-1519
john.c.peterson@verizon.com

December 1, 2004

Rian Wren
Senior Vice President and General Manager
Comcast Phone of Michigan, LLC d/b/a Comcast Digital Phone
1500 Market Street
Philadelphia, PA 19102

Re: Requested Adoption Under Section 252(i) of the TA96

Dear Mr. Wren:

Verizon North Inc., f/k/a GTE North Incorporated, Contel of the South, Inc., d/b/a Verizon North Systems ("Verizon"), a Wisconsin corporation, with principal place of business at 100 Executive Drive, Marion, Ohio 43302, has received your letter stating that, under Section 252(i) of the Telecommunications Act of 1996 (the "Act"), Comcast Phone of Michigan, LLC d/b/a Comcast Digital Phone ("CDP"), a Delaware limited liability company, with principal place of business at 1500 Market Street Philadelphia, Pennsylvania 19102, wishes to adopt the terms of the arbitrated Interconnection Agreement between AT&T Communications of Michigan Inc. ("AT&T") and Verizon that was approved by Michigan Public Service Commission (the "Commission") as an effective agreement in the State of Michigan in Docket No. U-11165, as such agreement exists on the date hereof (including any effective amendments thereto) after giving effect to operation of law (the "Terms"). I understand CDP has a copy of the Terms. Please note the following with respect to CDP's adoption of the Terms.

1. By CDP's countersignature on this letter, CDP hereby represents and agrees to the following six points:
 - A. CDP adopts (and agrees to be bound by) the Terms of the AT&T/Verizon arbitrated agreement for interconnection as it is in effect on the date hereof after giving effect to operation of law, and in applying the Terms,

agrees that CDP shall be substituted in place of AT&T Communications of Michigan Inc. and AT&T in the Terms wherever appropriate.

- B. For avoidance of doubt, adoption of the Terms does not include adoption of any provision imposing an unbundling obligation on Verizon that no longer applies to Verizon under the Report and Order and Order on Remand (FCC 03-36) released by the Federal Communications Commission ("FCC") on August 21, 2003 in CC Docket Nos. 01-338, 96-98, 98-147 ("Triennial Review Order"), the decision of the U.S. Court of Appeals for the D.C. Circuit in its Opinion and Order in United States Telecom Association v. Federal Communications Commission, 359 F.3d 554 (D.C. Cir. 2004) ("USTA II"), or that is otherwise not required by both 47 U.S.C. Section 251(c)(3) and 47 C.F.R. Part 51. Moreover, Verizon, on October 26, 2004, filed a petition at the Commission to arbitrate amendments to interconnection agreements (including the Terms) with respect to the Triennial Review Order ("TRO Arbitration"). If AT&T is a party to the TRO Arbitration at the time the Commission issues an effective order approving an amendment with respect to the Triennial Review Order in the TRO Arbitration (an "Approved Amendment"): 1) the terms of such Approved Amendment shall be deemed to amend this adoption effective on the effective date of such Commission order, 2) CDP agrees to be bound by the terms of such Approved Amendment effective on the effective date of such Commission order, and 3) Verizon and CDP shall execute an amendment to this adoption to memorialize that this adoption is amended by the terms of such Approved Amendment effective on the effective date of such Commission order; provided, however, failure by either party to do so shall not be cited as a basis for contesting the effectiveness of the provisions in 1) and 2) above.
- C. Notice to CDP and Verizon as may be required under the Terms shall be provided as follows:

To: Comcast Phone of Michigan, LLC
d/b/a Comcast Digital Phone
Attention: John G. Sullivan
1500 Market Street
Philadelphia, PA 19102
Telephone Number: (215) 981-8787
Facsimile Number: (215) 981-8508
Internet Address: John_Sullivan@Comcast.com

To Verizon:
Director-Contract Performance & Administration
Verizon Wholesale Markets
600 Hidden Ridge
HQEWMNOTICES

Irving, TX 75038
Telephone Number: 972-718-5988
Facsimile Number: 972-719-1519
Internet Address: wmnotices@verizon.com

with a copy to:

Vice President and Associate General Counsel
Verizon Wholesale Markets
1515 N. Court House Road
Suite 500
Arlington, VA 22201
Facsimile: 703-351-3664

- D. CDP represents and warrants that it is a certified provider of local telecommunications service in the State of Michigan, and that its adoption of the Terms will cover services in the State of Michigan only.
 - E. In the event an interconnection agreement between Verizon and CDP is currently in effect in the State of Michigan (the "Original ICA"), this adoption shall be an amendment and restatement of the operating terms and conditions of the Original ICA, and shall replace in their entirety the terms of the Original ICA. This adoption is not intended to be, nor shall it be construed to create, a novation or accord and satisfaction with respect to the Original ICA. Any outstanding payment obligations of the parties that were incurred but not fully performed under the Original ICA shall constitute payment obligations of the parties under this adoption.
 - F. Verizon's standard pricing schedule for interconnection agreements in the State of Michigan (as such schedule may be amended from time to time) (attached as Appendix A hereto) shall apply to CDP's adoption of the Terms. CDP should note that the aforementioned pricing schedule may contain rates for certain services the terms for which are not included in the Terms or that are otherwise not part of this adoption, and may include phrases or wording not identical to those utilized in the Terms. In an effort to expedite the adoption process, Verizon has not deleted such rates from the pricing schedule or attempted to customize the wording in the pricing schedule to match the Terms. However, the inclusion of such rates in no way obligates Verizon to provide the subject services and in no way waives Verizon's rights, and the use of slightly different wording or phrasing in the pricing schedule does not alter the obligations and rights set forth in the Terms.
2. CDP's adoption of the AT&T arbitrated Terms shall become effective on October 21, 2004. The parties understand and agree that Verizon shall file this adoption letter with the Commission promptly upon receipt of an original of this letter countersigned by CDP as to the points set out in paragraph one

hereof. The term and termination provisions of the AT&T/Verizon agreement shall govern CDP's adoption of the Terms. The adoption of the Terms is currently scheduled to expire on August 2, 2005.

3. As the Terms are being adopted by you pursuant to your statutory rights under section 252(i), Verizon does not provide the Terms to you as either a voluntary or negotiated agreement. The filing and performance by Verizon of the Terms does not in any way constitute a waiver by Verizon of any position as to the Terms or a portion thereof, nor does it constitute a waiver by Verizon of all rights and remedies it may have to seek review of the Terms, or to petition the Commission, other administrative body, or court for reconsideration or reversal of any determination made by the Commission pursuant to arbitration in Docket No. U-11165, or to seek review in any way of any provisions included in these Terms as a result of CDP's 252(i) election.
4. Nothing herein shall be construed as or is intended to be a concession or admission by Verizon that any contractual provision required by the Commission in Docket No. U-11165 (the AT&T arbitration) or any provision in the Terms complies with the rights and duties imposed by the Act, the decisions of the FCC and the Commission, the decisions of the courts, or other law, and Verizon expressly reserves its full right to assert and pursue claims arising from or related to the Terms.
5. Verizon reserves the right to deny CDP's adoption and/or application of the Terms, in whole or in part, at any time:
 - A. when the costs of providing the Terms to CDP are greater than the costs of providing them to AT&T;
 - B. if the provision of the Terms to CDP is not technically feasible; and/or
 - C. to the extent that Verizon otherwise is not required to make the Terms available to CDP under applicable law.
6. For avoidance of doubt, please note that adoption of the Terms will not result in reciprocal compensation payments for Internet traffic. Verizon has always taken the position that reciprocal compensation was not due to be paid for Internet traffic under section 251(b)(5) of the Act. Verizon's position that reciprocal compensation is not to be paid for Internet traffic was confirmed by the FCC in the Order on Remand and Report and Order adopted on April 18, 2001 ("*FCC Internet Order*"), which held that Internet traffic constitutes "information access" outside the scope of the reciprocal compensation obligations set forth in section 251(b)(5) of the Act.¹

¹ Order on Remand and Report and Order, In the Matters of: Implementation of the Local Competition Provisions in the Telecommunications Act of 1996 and Intercarrier Compensation for ISP-Bound Traffic, CC Docket No. 99-68 (rel. April 27, 2001) ("*FCC Remand Order*") ¶44, *remanded, WorldCom, Inc. v. FCC*, No. 01-1218 (D.C. Cir. May 3, 2002).

Accordingly, any compensation to be paid for Internet traffic will be handled pursuant to the terms of the *FCC Internet Order*, not pursuant to adoption of the Terms.² Moreover, in light of the *FCC Internet Order*, even if the Terms include provisions invoking an intercarrier compensation mechanism for Internet traffic, any reasonable amount of time permitted for adopting such provisions has expired under the FCC's rules implementing section 252(i) of the Act.³ In fact, the *FCC Internet Order* made clear that carriers may not adopt provisions of an existing interconnection agreement to the extent that such provisions provide compensation for Internet traffic.⁴

7. Should CDP attempt to apply the Terms in a manner that conflicts with paragraphs 3-6 above, Verizon reserves its rights to seek appropriate legal and/or equitable relief.
8. In the event that a voluntary or involuntary petition has been or is in the future filed against CDP under bankruptcy or insolvency laws, or any law relating to the relief of debtors, readjustment of indebtedness, debtor reorganization or composition or extension of debt (any such proceeding, an "Insolvency Proceeding"), then: (i) all rights of Verizon under such laws, including, without limitation, all rights of Verizon under 11 U.S.C. § 366, shall be preserved, and CDP's adoption of the Verizon Terms shall in no way impair such rights of Verizon; and (ii) all rights of CDP resulting from CDP's adoption of the Verizon terms shall be subject to and modified by any Stipulations and Orders entered in the Insolvency Proceeding, including, without limitation, any Stipulation or Order providing adequate assurance of payment to Verizon pursuant to 11 U.S.C. § 366.

Although the D.C. Circuit remanded the *FCC Remand Order* to permit the FCC to clarify its reasoning, it left the order in place as governing federal law. See *WorldCom, Inc. v. FCC*, No. 01-1218, slip op. at 5 (D.C. Cir. May 3, 2002).

² For your convenience, an industry letter distributed by Verizon explaining its plans to implement the *FCC Internet Order* can be viewed at Verizon's Customer Support Website at URL www.verizon.com/wise (select Verizon East Customer Support, Business Resources, Customer Documentation, Resources, Industry Letters, CLEC, May 21, 2001 Order on Remand).

³ See, e.g., 47 C.F.R. Section 51.809(c).

⁴ *FCC Internet Order* ¶ 82.

SIGNATURE PAGE

Please arrange for a duly authorized representative of CDP to sign this letter in the space provided below and return it to Verizon.

Sincerely,

VERIZON NORTH INC.
CONTEL OF THE SOUTH, INC., D/B/A VERIZON NORTH SYSTEMS

John C. Peterson, Director
Contract Performance and Administration

Reviewed and countersigned as to points A, B, C, D, E and F of paragraph 1:
COMCAST PHONE OF MICHIGAN, LLC D/B/A COMCAST DIGITAL PHONE

Rian Wren
Senior Vice President and General Manager

c: K. Robertson – Verizon

APPENDIX A¹
v1.4

I. Rates and Charges for Transport and Termination of Traffic²

A. Reciprocal Compensation Traffic Termination

Reciprocal Compensation Traffic End Office Rate: **\$0.0049291♣ per minute of use.**

Reciprocal Compensation Traffic Tandem Rate: **\$0.0083114♣ per minute of use.**

B. The Tandem Transit Service Charge is **\$0.0031360♣ per minute of use.**

Transit Service Billing Fee – Five percent (5%) of the Tandem Transit Traffic Service Charges assessed during the billing period for Tandem Transit Traffic exchanged with the relevant third party carriers.

Transit Service Trunking Charge (for each relevant third party carrier) – For each DS1 equivalent volume³ (or portion thereof) of Tandem Transit Traffic exchanged with the relevant third party carrier during a monthly billing period: an amount equal to the total monthly rate for 24 channels (DS1 equivalent) for Switched Access, Access Tandem Dedicated Trunk Port DS1, as set forth in Verizon Tariff FCC No. 14, as amended from time to time.

C. Entrance Facility and Transport for Interconnection Charges: **See Intrastate Special Access Tariff**

¹ In the event this Appendix A refers to a service that is not available under the Agreement, the Agreement shall control. Nothing in this Appendix A shall be deemed to require Verizon to provide a service that the Agreement does not require Verizon to provide.

² All rates and charges specified herein are pertaining to the Interconnection Attachment.

♣ Michigan Commission Rates, Case No. U-11832.

³ A CCS busy hour equivalent of 200,000 combined minutes of use.

II. Services Available for Resale

The avoided cost discount for all Resale services when Verizon provides Operator Services/Directory Assistance (OS/DA) is 15.80%. The avoided cost discount for all Resale services when Verizon does not provide OS/DA is 16.76%.

Non-Recurring Charges for Resale Services

Pre-ordering

CLEC Account Establishment Per CLEC	\$273.09
Customer Record Search Per Account	\$ 11.69

Ordering and Provisioning

Engineered Initial Service Order (ISO) - New Service	\$311.98
Engineered Initial Service Order - As Specified	\$123.84
Engineered Subsequent Service Order	\$ 59.61
Non-Engineered Initial Service Order - New Service	\$ 42.50
Non-Engineered Initial Service Order - Changeover	\$ 21.62
Non-Engineered Initial Service Order - As Specified	\$ 82.13
Non-Engineered Subsequent Service Order	\$ 19.55
Central Office Connect	\$ 12.21
Outside Facility Connect	\$ 68.30
Manual Ordering Charge	\$ 12.17

Product Specific:

NRCs, other than those for Pre-ordering, Ordering and Provisioning, and Custom Handling as listed in this Appendix, will be charged from the appropriate retail tariff. No discount applies to such NRCs.

Custom Handling:

Service Order Expedite:

Engineered	\$ 35.48
Non-Engineered	\$ 12.59

Coordinated Conversions:

ISO	\$ 17.76
Central Office Connection	\$ 10.71
Outside Facility Connection	\$ 9.59

Hot Coordinated Conversion First Hour:

ISO	\$ 30.55
Central Office Connection	\$ 42.83
Outside Facility Connection	\$ 38.34

Hot Coordinated Conversion per Additional Quarter Hour:

ISO	\$ 4.88
Central Office Connection	\$ 9.43
Outside Facility Connection	\$ 8.37

Application of NRCs

Pre-ordering:

CLEC Account Establishment is a one-time charge applied the first time that CDP orders any service from this Agreement.

Customer Record Search applies when CDP requests a summary of the services currently subscribed to by the end-user.

Ordering and Provisioning:

Engineered Initial Service Order - New Service applies per Local Service Request (LSR) when engineering work activity is required to complete the order, e.g. digital loops.

Non-Engineered Initial Service Order - New Service applies per LSR when no engineering work activity is required to complete the order, e.g. analog loops.

Initial Service Order - As Specified (Engineered or Non-Engineered) applies only to Complex Services for services migrating from Verizon to CDP. Complex Services are services that require a data gathering form or has special instructions.

Non-Engineered Initial Service Order - Changeover applies only to Basic Services for services migrating from Verizon to CDP. End-user service may remain the same or change.

Central Office Connect applies in addition to the ISO when physical installation is required at the central office.

Outside Facility Connect applies in addition to the ISO when incremental fieldwork is required.

Manual Ordering Charge applies to orders that require Verizon to manually enter CDP's order into Verizon's Secure Integrated Gateway System (SIGS), e.g. faxed orders and orders sent via physical or electronic mail.

Custom Handling (These NRCs are in addition to any Preordering or Ordering and Provisioning NRCs):

Service Order Expedite (Engineered or Non-Engineered) applies if CDP requests service prior to the standard due date intervals.

Coordinated Conversion applies if CDP requests notification and coordination of service cut over prior to the service becoming effective.

Hot Coordinated Conversion First Hour applies if CDP requests real-time coordination of a service cut-over that takes one hour or less.

Hot Coordinated Conversion Per Additional Quarter Hour applies, in addition to the Hot Coordinated Conversion First Hour, for every 15-minute segment of real-time coordination of a service cut-over that takes more than one hour.

III. Prices for Unbundled Network Elements

Monthly Recurring Charges

Local Loop

2 Wire Analog Loop (inclusive of NID)	\$	26.16♣
4 Wire Analog Loop (inclusive of NID)	\$	42.09♣
2 Wire Digital Loop (inclusive of NID)	\$	26.16♣
4 Wire Digital Loop (inclusive of NID)	\$	42.09♣
DS-1 Loop	\$	135.44
DS-3 Loop	\$	1081.93

Supplemental Features:

ISDN-BRI Line Loop Extender	\$	4.32
DS1 Clear Channel Capability	\$	24.00

Sub-Loop

2-Wire Feeder	\$	13.25♣
2-Wire Distribution	\$	15.33♣
4-Wire Feeder		\$16.29♣
4-Wire Distribution	\$	28.23♣
2-Wire Drop	\$	2.58♣
4-Wire Drop	\$	4.44♣
Inside Wire		BFR

Network Interface Device (leased separately)

Basic NID	\$.77♣
Complex (12 x) NID	\$	1.80

Switching

Port		
Basic Analog Line Side Port	\$	4.27♣
Coin Line Side Port	\$	8.66
ISDN BRI Digital Line Side Port	\$	16.42
DS-1 Digital Trunk Side Port	\$	84.81♣
ISDN PRI Digital Trunk Side Port	\$	360.72

Usage Charges (must purchase Port)

Local Central Office Switching (Overall Average MOU)	\$	0.0049291♣
Common Shared Transport		
Transport Facility (Average MOU/ALM)	\$	0.0000226♣
Transport Termination (Average MOU/Term)	\$	0.0002463♣
Tandem Switching (Average MOU)	\$	0.0025055♣

Terminating to Originating Ratio 1.00

♣ Michigan Commission Rates, Case No. U-11832

Dedicated Transport Facilities

CLEC Dedicated Transport		
CDT 2 Wire	\$	43.91♣
CDT 4 Wire	\$	58.47♣
CDT DS1		
First System	\$	102.35♣
Additional System	\$	102.35♣
CDT DS3 Optical Interface	\$	159.92♣
CDT DS3 Electrical Interface	\$	325.17♣
Interoffice Dedicated Transport		
IDT DS0 Transport Facility per ALM	\$	0.20♣
IDT DS0 Transport Termination	\$	22.99♣
IDT DS1 Transport Facility per ALM	\$	8.41♣
IDT DS1 Transport Termination	\$	91.84♣
IDT DS3 Transport Facility per ALM	\$	64.25♣
IDT DS3 Transport Termination	\$	387.77♣
Multiplexing		
DS1 to Voice Multiplexing	\$	341.49♣
DS3 to DS1 Multiplexing	\$	821.69♣
DS1 Clear Channel Capability	\$	24.00
Unbundled Dark Fiber		
Unbundled Dark Fiber Loops/Sub-Loops		
Dark Fiber Loop	\$	67.13
Dark Fiber Sub-Loop – Feeder	\$	53.17
Dark Fiber Sub-Loop – Distribution	\$	13.96
Unbundled Dark Fiber Dedicated Transport		
Dark Fiber IDT –Facility	\$	24.80
Dark Fiber IDT –Termination	\$	6.34
Intermediate Office Cross Connect		TBD

♣ Michigan Commission Rates, Case No. U-11832

UNE-P Pricing

MRCs. The MRC for a UNE-P will generally be equal to the sum of the MRCs for the combined UNEs (e.g. the total of the UNE loop charge plus the UNE port charges in the Agreement (see Note A) plus: UNE local switching (per minute originating usage plus T/O factor to determine terminating minutes) based on UNE local switching rates in the Agreement plus UNE shared transport and tandem switching (based on factors for percent interoffice and tandem switch usage, plus assumed transport mileage of 10 miles and 2 terms) based on UNE shared transport rates in the Agreement plus UNE Vertical Services charges (optional per line charges, if allowed by the Agreement).

(Note A): UNE platforms are available in four loop/port configurations as shown below. If the price for any component of these platforms is not set forth herein, Verizon will use the ICB process to determine the appropriate price and TBD pricing shall apply.

UNE Basic Analog Voice Grade Platform consists of the following components:

- UNE 2-wire Analog loop; and
- UNE Basic Analog Line Side port

UNE ISDN BRI Platform consists of the following components:

- UNE 2-wire Digital loop; and
- UNE ISDN BRI Digital Line Side port

UNE ISDN PRI Platform consists of the following components:

- UNE DS1 loop; and
- UNE ISDN PRI Digital Trunk Side port

UNE DS1 Platform consists of the following components:

- UNE DS1 loop; and
- UNE DS1 Digital Trunk Side port

NRCs. Optional NRCs will apply as ordered by the CLEC including such charges as Expedites, Coordinated Conversions, loop Conditioning, etc.

EEL Pricing

MRCs. The MRCs for an EEL will generally be equal to the applicable MRCs for UNEs and Multiplexing that comprise an EEL arrangement (e.g. UNE Loop, IDT, CDT, Multiplexing, & Clear Channel Capability).

Line Splitting⁴

Except as noted in the following paragraph, the provider of voice services in a Line Splitting arrangement ("VLEC") will be billed for all charges associated with the Network Elements and other Verizon services, facilities and arrangements, used in conjunction with the Line Splitting arrangement ("Line Splitting Arrangement"), regardless of which CLEC in the Line Splitting Arrangement orders the Network Elements or other Verizon services, facilities or arrangements. These charges include, but are not limited to, all applicable non-recurring charges and monthly recurring charges related to such Line Splitting Arrangement, including but not limited to UNE-P (2-wire digital UNE loop or 2-wire ADSL capable UNE loop, UNE switch port, UNE local switching usage, UNE local transport and usage rates), testing, pre-qualification, OSS, line conditioning, CLEC account establishment and misdirected trouble charges.

The CLEC with the applicable collocation arrangement will be billed for splitter establishment and collocation related charges.

⁴ Rates for the individual line splitting components are contained in existing terms for Unbundled Network Elements and Collocation.

NON-RECURRING CHARGES

Loops, Sub-Loops and Ports-Analog	
Service Ordering (Loop Sub-Loop or Port)	
Initial Service Order, per order	\$ 5.00♣
Transfer of Service Charge, per order	\$ 5.00♣
Subsequent Service Order, per order	\$ 5.00♣
Installation	
Unbundled Loop, per loop and sub-loop	\$ 2.32♣
Unbundled Port, per port	\$ 2.32♣
Loop Facility Charge, per trip ⁵	\$ 12.75♣
Trouble Isolation Charge (TIC) Per Qtr. Hour and Subsequent Qtr. Hour thereafter.	\$ 7.00
Customer Service Record Research	
Per Request	\$ 5.00♣
Loops and Ports-Digital (2 and 4 Wire Compatible Digital Loops)	
Service Ordering (Loop or Port)	
Initial Service Order, per order	\$ 5.00♣
Transfer of Service Charge, per order	\$ 5.00♣
Subsequent Service Order, per order	\$ 5.00♣
Installation	
Unbundled Loop, per loop and sub-loop	\$ 2.32♣
Unbundled Port, per port	\$ 2.32♣
Loop Facility Charge, per trip	\$ 12.75♣
Customer Service Record Research	
Per Request	\$ 5.00♣
Engineering Query Charge	TBD
Engineering Work Order Charge	TBD
Line and Station Transfer Charge	\$ 154.53

⁵ The Loop Facility Charge will apply when fieldwork is required for establishment of a new unbundled loop service.

♣ Michigan Commission Rates, Case No. U-11832

CUSTOM HANDLING

Coordinated Conversions:

ISO	\$ 17.76
Central Office Connection	\$ 9.43
Outside Facility Connection	\$ 8.09

Hot Coordinated Conversions First Hour:

ISO	\$ 23.91
Central Office Connection	\$ 37.72
Outside Facility Connection	\$ 32.36

Hot Coordinated Conversions per Additional Quarter Hour:

ISO	\$ 4.88
Central Office Connection	\$ 9.43
Outside Facility Connection	\$ 8.37

NON-RECURRING CHARGES – OTHER UNE’s & Misc.

LOCAL WHOLESALE SERVICES	Ordering 100% Manual	Ordering Semi- Mech.	Provisioning Initial Unit	Add'l Unit
UNBUNDLED NID				
Exchange – Basic	\$ 27.06	\$ 18.83	\$ 33.99	N/A
UNBUNDLED DARK FIBER				
Advanced - Service Inquiry Charge	\$405.87	\$405.65	N/A	N/A
Advanced - Interoffice Dedicated Transport - Initial	\$ 64.80	\$ 64.57	\$267.28	\$224.68
Advanced - Unbundled Loop - Initial	\$ 64.80	\$ 64.57	\$261.86	\$220.43
Advanced - Sub-Loop Feeder - Initial	\$ 64.80	\$ 64.57	\$261.86	\$220.43
Advanced - Sub-Loop Distribution - Initial	\$ 64.80	\$ 64.57	\$264.84	\$216.19
Dark Fiber Record Review (with reservation)	TBD			
Intermediate Office Cross Connect	TBD			
Dark Fiber Optional Engineering Services	TBD			
ENHANCED EXTENDED LINK EXTENDED LOOPS (EELs) Loop portion (In addition, IDT and CDT charges apply if applicable to the EEL arrangement)				
Advanced - Basic (2-wire and 4-wire) - Initial	\$ 88.39	\$ 56.13	\$ 2.32	N/A
Advanced - Basic (2-wire and 4-wire) - Subsequent	\$ 38.02	\$ 21.89	\$ 2.32	N/A
DS1/DS3 - Initial	\$ 97.94	\$ 65.68	\$ 2.32	N/A
DS1/DS3 - Subsequent	\$ 38.02	\$ 21.89	\$ 2.32	N/A
DS3 to DS1 Multiplexer	N/A	N/A	\$450.00	N/A
DS1 to DS0 Multiplexer	N/A	N/A	\$800.00	N/A
Changeover Charge - (Conversion from Special Access to EELs or Transport)				
Advanced - Basic (2-wire and 4-wire) Changeover (As Is)	\$161.87	\$ 99.77	\$ 41.64	N/A
Advanced - Basic (2-wire and 4-wire) Changeover (As Is)- Additional MOG (Mass Order Generator) Only	\$ 7.52	\$ 4.56	\$ 41.64	N/A
Advanced - Complex (DS1 and above) Changeover (As Is)	\$179.37	\$117.27	\$ 41.64	N/A
Advanced - Complex (DS1 and above) Changeover (As Is)- Additional MOG (Mass Order Generator) Only	\$ 7.52	\$ 4.56	\$ 41.64	N/A
LOOP CONDITIONING⁶ (No charge for load coil or excessive bridged tap removal on loops 12,000 feet or less)				
Loop Conditioning - Bridged Tap	N/A	N/A	\$318.71	\$ 34.88
Loop Conditioning - Bridged Tap Removal Only	N/A	N/A	\$318.71	N/A
Loop Conditioning - Load Coils (loops greater than 12,000 feet)	N/A	N/A	\$249.91	N/A
Loop Conditioning - Load Coil Removal Only	N/A	N/A	\$249.91	N/A
Loop Conditioning - Load Coils / Bridged Tap	N/A	N/A	\$568.62	\$ 34.88
Loop Conditioning – Bridged Tap and Load Coil Removal	N/A	N/A	\$568.62	N/A

⁶ These charges are interim and subject to retroactive true-up back to the Effective Date of this Adoption of the Terms.

UNE PLATFORM

Exchange - Basic - Initial	\$ 31.57	\$ 22.13	\$ 28.23	\$ 26.58
Exchange - Basic - Subsequent	\$ 16.44	\$ 13.26	\$ 1.08	\$ 1.08
Exchange - Basic - Changeover	\$ 19.93	\$ 15.54	\$ 0.90	\$ 0.90
Exchange - Complex Non-Digital - Initial	\$ 41.35	\$ 27.53	\$162.41	\$ 31.70
Exchange - Complex Non-Digital - Subsequent (Port Feature)	\$ 16.44	\$ 13.26	\$ 5.89	\$ 5.89
Exchange - Complex Non-Digital - Subsequent (Switch Feature Group)	\$ 20.82	\$ 13.26	\$ 22.73	\$ 22.73
Exchange - Complex Non-Digital - Changeover (As Is)	\$ 22.35	\$ 17.96	\$ 3.61	\$ 3.61
Exchange - Complex Non-Digital - Changeover (As Specified)	\$ 30.08	\$ 21.31	\$ 20.97	\$ 3.61
Exchange - Complex Digital - Initial	\$ 41.35	\$ 27.53	\$205.75	\$ 28.18
Exchange - Complex Digital - Subsequent (Port Feature)	\$ 16.44	\$ 13.26	\$ 5.15	\$ 5.15
Exchange - Complex Digital - Subsequent (Switch Feature Group)	\$ 20.82	\$ 13.26	\$ 22.73	\$ 22.73
Exchange - Complex Digital - Changeover (As Is)	\$ 22.35	\$ 17.96	\$ 4.18	\$ 4.18
Exchange - Complex Digital - Changeover (As Specified)	\$ 30.08	\$ 21.31	\$ 80.98	\$ 4.18
Advanced - Complex - Initial	\$ 48.35	\$ 34.53	\$681.24	\$303.66
Advanced - Complex - Subsequent	\$ 20.82	\$ 13.26	\$ 65.81	\$ 48.47
Advanced - Complex - Changeover (As Is)	\$ 24.06	\$ 19.67	\$ 51.51	\$ 34.17
Advanced - Complex - Changeover (As Specified)	\$ 37.08	\$ 28.31	\$ 82.31	\$ 64.97

INTEROFFICE DEDICATED TRANSPORT (IDT)(Also applies to IDT portion of an EEL arrangement)

Advanced - Basic (2-wire and 4-wire) - Initial	\$ 95.49	\$ 63.01	\$428.58	N/A
Advanced - Basic(2-wire and 4-wire) - Subsequent	\$ 45.12	\$ 28.77	\$ 58.20	N/A
Advanced - Complex (DS1 and above)- Initial	\$105.04	\$ 72.56	\$584.49	N/A
Advanced - Complex (DS1 and above)- Subsequent	\$ 45.12	\$ 28.77	\$ 86.80	N/A

CLEC DEDICATED TRANSPORT (CDT)

Entrance Facility/Dedicated Transport DS0 - Initial	\$ 95.49	\$ 63.01	\$390.08	N/A
Entrance Facility/Dedicated Transport DS0 - Subsequent	\$ 45.12	\$ 28.77	\$ 58.20	N/A
Entrance Facility/Dedicated Transport DS1/DS3 - Initial	\$105.04	\$ 72.56	\$515.03	N/A
Entrance Facility/Dedicated Transport DS1/DS3 - Subsequent	\$ 45.12	\$ 28.77	\$ 86.80	N/A
Clear Channel Capability	N/A	N/A	\$ 90.00	N/A

SIGNALING SYSTEM 7 (SS7)

Facilities and Trunks - Initial	\$237.67	\$205.19	\$568.54	N/A
Facilities and Trunks - Subsequent (with Engineering Review)	\$ 71.58	\$ 55.23	\$213.12	N/A
Facilities and Trunks - Subsequent (w/o Engineering Review)	\$ 71.58	\$ 55.23	\$ 67.28	N/A
Trunks Only - Initial	\$126.13	\$ 93.65	\$505.41	N/A
Trunks Only - Subsequent (with Engineering Review)	\$ 49.46	\$ 33.11	\$202.03	N/A
Trunks Only - Subsequent (w/o Engineering Review)	\$ 49.46	\$ 33.11	\$ 67.28	N/A
STP Ports (SS7 Links)	\$237.67	\$205.19	\$438.81	N/A

CUSTOMIZED ROUTING

BFR	BFR	BFR	BFR
-----	-----	-----	-----

EXPEDITES

Exchange Products	\$ 3.36	\$ 3.36	N/A	N/A
Advanced Products	\$ 25.80	\$ 25.80	N/A	N/A

OTHER

CLEC Account Establishment (per CLEC)	\$166.32	\$166.32	N/A	N/A
Design Change Charge - EELs and Transport	\$ 27.00	\$ 27.00	N/A	N/A

LINE SHARING - CLEC OWNED SPLITTER⁷

CLEC Splitter Connection - Initial	\$ 32.19	\$ 22.52	\$ 53.04	\$ 47.29
CLEC Splitter Connection - Subsequent	\$ 13.24	\$ 9.83	\$ 14.49	\$ 13.53

⁷ Line Sharing Collocation application, Augment and Cross Connect Charges apply. See Section V. for Collocation rates.

Application of NRCs

Preordering:

CLEC Account Establishment is a one-time charge applied the first time that CDP orders any service from this Agreement.

Customer Record Search applies when CDP requests a summary of the services currently subscribed to by the end-user.

Ordering and Provisioning:

Initial Service Order (ISO) applies to each Local Service Request (LSR) and Access Service Request (ASR) for new service. Charge is Manual (e.g. for a faxed order) or Semi-Mechanized (e.g. for an electronically transmitted order) based upon the method of submission used by the CLEC.

Subsequent Service Order applies to each LSR/ASR for modifications to an existing service. Charge is Manual or Semi-Mechanized based upon the method of submission used by the CLEC.

Advanced ISO applies per LSR/ASR when engineering work activity is required to complete the order.

Exchange ISO applies per LSR/ASR when no engineering work activity is required to complete the order.

Provisioning – Initial Unit applies per ISO for the first unit installed. The Additional Unit applies for each additional unit installed on the same ISO.

Basic Provisioning applies to services that can be provisioned using standard network components maintained in inventory without specialized instructions for switch translations, routing, and service arrangements.

Complex Provisioning applies to services that require special instruction for the provisioning of the service to meet the customer's needs.

Examples of services and their Ordering/Provisioning category that applies:

Exchange-Basic: 2-Wire Analog, 4-Wire Analog, Standard Sub-Loop Distribution, Standard Sub-Loop Feeder, Drop and NID.

Exchange-Complex: Non-loaded Sub-Loop Distribution, Non-load Sub-Loop Feeder, Loop Conditioning, Customized Routing, ISDN BRI Digital Line Side Port and Line Sharing.

Advanced-Basic: 2-Wire Digital Loop, 4-Wire Digital Loop

Advanced-Complex: DS1 Loop, DS3 Loop, Dark Fiber, EELs, and ISDN PRI Digital Trunk Side Port

Conditioning applies in addition to the ISO, for each Loop or Sub-Loop UNE for the installation and grooming of Conditioning requests.

DS1 Clear Channel Capability applies in addition to the ISO, per DS1 for the installation and grooming of DS1 Clear Channel Capability requests.

Changeover Charge applies to UNE-P and EEL orders when an existing retail, resale, or special access service is already in place.

Service Inquiry – Dark Fiber applies per service inquiry when a CLEC requests Verizon to determine the availability of dark fiber on a specific route.

EELs - The NRCs that generally apply to an EEL arrangement are applicable ordering & provisioning charges for EEL Loops, IDT, CDT, Multiplexing and Clear Channel Capability

Custom Handling (These NRCs are in addition to any Preordering or Ordering and Provisioning NRCs):

Service Order Expedite applies if CDP requests service prior to the standard due date intervals and the expedite request can be met by Verizon.

Coordinated Conversion applies if CDP requests notification and coordination of service cut-over prior to the service becoming effective.

Hot Coordinated Conversion First Hour applies if CDP requests real-time coordination of a service cut-over that takes one hour or less.

Hot Coordinated Conversion Per Additional Quarter Hour applies, in addition to the Hot Coordinated Conversion First Hour, for every 15-minute segment of real-time coordination of a service cut-over that takes more than one hour.

Design Change Charge applies to EELs & Transport orders for design changes requested by the CLEC.

Engineering Work Order applies, where available, if CDP requests conditioning activity (i.e., removal of Load Coils, Bridged Taps).

Engineering Query applies, where available, if CDP requests further detailed analysis of individual Loop characteristics.

Line and Station Transfer applies where Verizon swaps facilities in order to provision a Copper Facility.

IV. Rates and Charges for 911

See State Tariff.

V. Collocation Rates

See MI Local Network Access Services Tariff, MPSC #20R.

INTERCONNECTION, RESALE
AND UNBUNDLING

AGREEMENT

between

GTE NORTH INCORPORATED AND CONTEL OF THE SOUTH, INC., d/b/a GTE
SYSTEMS OF MICHIGAN

and

AT&T COMMUNICATIONS OF MICHIGAN, INC.

The filing of this arbitrated Agreement with the Michigan Public Service Commission in accordance with the Order Approving Agreement Adopted by Arbitration, dated December 12, 1996 (the "Order") of the Michigan Public Service Commission, with respect to AT&T Communications of Michigan, Inc.'s Petition for Arbitration of Interconnection Terms, Conditions and Prices from GTE North, Incorporated and Contel of the South, Inc., d/b/a/ GTE Systems of Michigan, Case No. U-11165, does not in any way constitute a waiver by either AT&T Communications of Michigan, Inc., GTE North, Incorporated or Contel of the South, Inc., d/b/a/ GTE Systems of Michigan, Inc. of any right which any such Party may have to appeal to a competent court of law, or to petition the Michigan Public Service Commission for reconsideration of, any determination contained in the Order, the decision of the Arbitration Panel, dated November 12, 1996 (the "Decision") with respect to the foregoing, or any provision included in this Agreement pursuant to the Order or the Decision.

In this document the Parties attempt to comply with the Decision as modified by the Order which directs the Parties to reduce to contractual language the substantive provisions and directives of the Decision and the Order. Nothing contained herein shall be construed or is intended to be a concession or admission by either Party that any such provision of the Decision and the Order or the language herein complies with the duties imposed by the Telecommunications Act of 1996, the decisions of the FCC and the Michigan Public Service Commission, or other law, and each Party thus expressly reserves its full right to assert and pursue claims that the Decision and the Order do not comport with applicable law.

EXPLANATION OF CONTRACT MARKINGS:

PLAIN TEXT

AGREED LANGUAGE, UNLESS
OTHERWISE INDICATED ON
THE DOCUMENT

BOLD TEXT

AT&T PROPOSAL (RELATED TO THE
"COMBINATIONS AND UNUSED
TRANSMISSION MEDIA ISSUE") TO WHICH
GTE HAS NOT AGREED

DOUBLE UNDERLINED
TEXT

GTE PROPOSAL (RELATED TO THE
"COMBINATIONS AND UNUSED
TRANSMISSION MEDIA ISSUE") TO WHICH
AT&T HAS NOT AGREED

"Combinations and Unused
Transmission Media Issue"
Markings:

SECTION CONTAINS DISPUTED
LANGUAGE RELATED TO THE
"COMBINATIONS AND UNUSED
TRANSMISSION MEDIA ISSUE"

TABLE OF CONTENTS

<u>Section</u>	<u>Page</u>
PREFACE.....	5
AGREEMENT	5
RECITALS.....	6
SCOPE, INTENT AND DEFINITIONS.....	7
GENERAL TERMS AND CONDITIONS	8
1. PROVISION OF LOCAL SERVICE, UNBUNDLED NETWORK ELEMENTS AND INTERCONNECTION.....	8
2. TERM OF AGREEMENT	9
3. TERMINATION OF AGREEMENT; TRANSITIONAL SUPPORT	11
4. GOOD FAITH PERFORMANCE	12
5. SECTION 252 (I) ELECTION.....	12
6. RESPONSIBILITY OF EACH PARTY	12
7. GOVERNMENTAL COMPLIANCE.....	13
8. RESPONSIBILITY FOR ENVIRONMENTAL CONTAMINATION.....	13
9. REGULATORY MATTERS	13
10. LIABILITY AND INDEMNITY.....	17
11. SERVICE PARITY AND STANDARDS	19
12. CUSTOMER CREDIT HISTORY	20
13. FORCE MAJEURE	21
14. CERTAIN STATE AND LOCAL TAXES.....	21
15. ALTERNATIVE DISPUTE RESOLUTION	22
16. NOTICES	22
17. CONFIDENTIALITY AND PROPRIETARY INFORMATION.....	23
18. BRANDING	25
19. DIRECTORY LISTINGS AND DIRECTORY DISTRIBUTION	26
20. DIRECTORY ASSISTANCE LISTING INFORMATION.....	30

21. BUSY LINE VERIFICATION AND BUSY LINE VERIFICATION INTERRUPT	30
22. NUMBER ASSIGNMENT	30
23. MISCELLANEOUS.....	31
PART I LOCAL SERVICES RESALE	36
24. TELECOMMUNICATIONS SERVICES PROVIDED FOR RESALE	36
25. GENERAL TERMS AND CONDITIONS FOR RESALE.....	36
26. REQUIREMENTS FOR SPECIFIC SERVICES	38
27. ADVANCED INTELLIGENT NETWORK.....	40
28. ROUTING TO DIRECTORY ASSISTANCE, OPERATOR AND REPAIR SERVICES.....	40
29. SERVICE SUPPORT FUNCTIONS.....	43
30. PAY PHONE LINES AND PAY PHONE SERVICES.....	48
PART II: UNBUNDLED NETWORK ELEMENTS	51
31. INTRODUCTION	51
32. UNBUNDLED NETWORK ELEMENTS	51
PART III: ANCILLARY FUNCTIONS	56
33. INTRODUCTION	56
34. GTE PROVISION OF ANCILLARY FUNCTIONS	56
35. STANDARDS FOR ANCILLARY FUNCTIONS.....	56
PART IV: INTERCONNECTION PURSUANT TO SECTION 251(C)(2).....	58
36. SCOPE	58
37. INTERCONNECTION POINTS AND METHODS.	58
38. TRANSMISSION AND ROUTING OF TELEPHONE EXCHANGE SERVICE TRAFFIC PURSUANT TO SECTION 251(C)(2)	64
39. TRANSMISSION AND ROUTING OF EXCHANGE ACCESS TRAFFIC.....	67
40. TRANSPORT AND TERMINATION OF INFORMATION SERVICES TRAFFIC	68
41. INSTALLATION, MAINTENANCE, TESTING AND REPAIR	69
42. GENERAL PRINCIPLES	70
43. PRICE SCHEDULES.....	70

ATTACHMENTS

Attachment 1	Alternative Dispute Resolution
Attachment 2	Services Description: Unbundled Network Elements ("UNE")
Attachment 3	Service Description: Ancillary Functions
Attachment 4	Provisioning and Ordering - UNE
Attachment 5	Maintenance for Local Services Resale and UNE
Attachment 6	Local Services Resale, UNE and Interconnection Billing and Recording
Attachment 7	Provision of Customer Usage Data
Attachment 8	Local Number Portability
Attachment 9	Network Security
Attachment 10	Acronyms
Attachment 11	Definitions
Attachment 12	Service Quality Standards and Processes
Attachment 13	[Intentionally Deleted.]
Attachment 14	Pricing
Attachment 15	Reciprocal Compensation For Call Termination Agreement

PREFACE

AGREEMENT

This Agreement is entered into by and between AT&T Communications of Michigan, Inc., a Michigan corporation having an office at 227 West Monroe, 13th Floor, Chicago, Illinois 60606, in its capacity as a certified provider of local dial-tone service ("AT&T"), and GTE North Incorporated, a Wisconsin corporation, and Contel of the South, Inc. d/b/a GTE Systems of Michigan, a Georgia corporation, each having an office for purposes of this Agreement at 600 Hidden Ridge Drive, Irving, Texas 75038 (individually and collectively "GTE"), each in its capacity as an incumbent local exchange carrier. This Agreement covers services only in the state of Michigan (the "State").

RECITALS

WHEREAS, The Telecommunications Act of 1996 (the "Act") was signed into law on February 8, 1996; and

WHEREAS, the Act places certain duties and obligations upon, and grants certain rights to, Telecommunications Carriers, with respect to the interconnection of their networks, resale of their telecommunications services, access to their poles, ducts, conduits and rights of way and, in certain cases, the offering of certain unbundled network elements and physical collocation of equipment in Local Exchange Carrier premises, and

WHEREAS, GTE is an Incumbent Local Exchange Carrier; and

WHEREAS, AT&T is a Telecommunications Carrier and has requested that GTE negotiate an agreement with AT&T for the provision of Network Elements, Local Services for resale, collocation and access to poles, ducts, conduits and rights of way and the reciprocal provision of interconnection services pursuant to the Act and in conformance with GTE's and AT&T's duties under the Act; and

WHEREAS, interconnection between competing Local Exchange Carriers (LECs) is necessary and desirable for the mutual exchange and termination of traffic originating on each LEC's network and the Parties desire to exchange such traffic and related signaling in a technically and economically efficient manner at defined and mutually agreed upon points of interconnection.

SCOPE, INTENT AND DEFINITIONS

This Agreement governs the purchase by AT&T of certain telecommunications services provided by GTE in its service areas for resale by AT&T, the purchase by AT&T of certain unbundled network elements from GTE, the terms and conditions of the collocation of certain equipment of AT&T in the premises of GTE, the provision by GTE of access to its poles, conduits and rights of way and the reciprocal interconnection of each Party's local facilities for the exchange of traffic. Neither Party is entering into this Agreement as a CMRS Provider. A separate agreement will be required for any exchange of traffic as a CMRS Provider.

The Parties agree that their entry into this Agreement is without prejudice to any positions they may have taken previously, or may take in the future, in any legislative, regulatory, judicial or other public forum addressing any matters, including matters related to the same types of arrangements covered in this Agreement.

For purposes of this Agreement, certain terms have been defined in Attachment 11 and elsewhere in this Agreement to encompass meanings that may differ from the normal connotation of the defined word. A defined word intended to convey its special meaning is capitalized when used. Unless the context clearly indicates otherwise, any term defined or used in the singular shall include the plural. The words "shall" and "will" are used interchangeably throughout this Agreement and the use of either connotes a mandatory requirement. The use of one or the other shall not mean a different degree of right or obligation for either Party. Other terms that are capitalized, and not defined in this Agreement, shall have the meaning given them in the Act. For convenience of reference only, Attachment 10 provides a list of acronyms used throughout this Agreement.

GENERAL TERMS AND CONDITIONS

1. Provision of Local Service, Unbundled Network Elements and Interconnection

This Agreement, which consists of these General Terms and Conditions and Attachments 1-15 and their accompanying Appendices, sets forth the terms, conditions and prices under which GTE agrees to provide (a) telecommunications services for resale (hereinafter referred to as "Local Services") and (b) certain unbundled Network Elements, Ancillary Functions and additional features to AT&T **or combinations of such Network Elements ("Combinations")**, for purposes of offering telecommunications services of any kind, including, but not limited to, local exchange services, intrastate toll services, and intrastate and interstate exchange access services and (c) access to GTE's poles, conduits and rights of way. This Agreement also sets forth the terms and conditions for the interconnection of AT&T's local network to GTE's local network ("Interconnection Services") and the reciprocal compensation to be paid by each Party to the other for the transport and termination of Local Traffic of the other Party. The Network Elements, **Combinations** or Local Services provided pursuant to this Agreement may be connected to other Network Elements, **Combinations** or Local Services provided by GTE or to any Network Elements, **Combinations** or Local Services provided by AT&T itself or by any other vendor. Subject to the requirements of this Agreement, AT&T may, at any time add or delete the Local Services, or Network Elements **or Combinations** purchased hereunder. In no event shall any provision of this Agreement obligate GTE to provide AT&T with interconnection that is superior in quality to that provided by GTE to itself, its affiliates, or other third parties to which GTE provides interconnection or that GTE is not otherwise required to provide under Applicable Law. Additionally, the network elements to which this Agreement requires GTE to provide access shall be only such network elements as to which provision of access by GTE is required under Applicable Law and no provision of this Agreement shall require or be interpreted to require GTE to provide access to network elements to which GTE is not required to provide access under Applicable Law. For example, references to network elements contained in this Agreement shall not require GTE to provide access to any network element that is not part of GTE's existing network at the time AT&T places an order for such network element nor shall such references require GTE to provide access to any unbuilt superior network at the time of an AT&T order.

[Combinations]

1.1 **Unbundled Network Elements and Combinations:**

On January 25, 1999, the United States Supreme Court vacated 47 C.F.R. 51.319 ("FCC Rule 319") which was in effect at the time the Commission conducted the arbitration proceeding and issued its Orders pursuant to which this Agreement was produced (the "Commission's Orders"). GTE believes that as a result of the Court's decision it is not legally obligated to unbundle the network elements identified by the Commission's Orders. The Parties anticipate, however, that the FCC will issue new final rules regarding unbundling of network elements (the "New Rules"). The Court also ruled that 47 C.F.R. 315(b), concerning combinations of currently-combined network elements is lawful. AT&T believes that pursuant to the Court's decision and other Applicable Law AT&T is legally entitled to obtain Combinations from GTE.

Notwithstanding GTE's understanding of its current legal obligations, and without waiving any of its rights including, but not limited to, its rights to seek recovery of its actual costs and a sufficient explicit universal service fund, and its right to assert that under the Court's decision it is not required to provide unbundled network elements unconditionally, GTE will provide to AT&T, subject to the terms and conditions set forth herein, the individual unbundled network elements common to FCC Rule 319 and Section 32.9 of this Agreement until the FCC issues the New Rules.

Notwithstanding AT&T's understanding of its current legal right to obtain Unused Transmission Media and Combinations from GTE, AT&T, without waiver of any of its rights concerning Combinations and Unused Transmission Media including, but not limited to, the right to obtain such Combinations, agrees not to seek or require GTE to provide Unused Transmission Media or Combinations in the State until the FCC issues the New Rules, and sections contained in this Agreement that are identified as containing issues with regard to Unused Transmission Media and Combinations shall be of no force and effect to the extent they require or raise issues with regard to provision of Unused Transmission Media and Combinations.

Subject to the terms and conditions of this Section 1.1, neither Party desires to delay either approval or implementation of the terms and conditions of this Agreement in the normal course under the Act, other than those related to Unused Transmission Media and the Combination issue. Neither Party desires to relinquish its rights as they pertain to unbundled network elements or the Combinations; and neither party does relinquish its rights by virtue of these provisions. The Parties therefore agree that the provisions of this Agreement related to Unused Transmission Media and Combinations are identified and are intended to be left unresolved until after the FCC issues its New Rules. The Parties intend that when this Agreement is submitted to the

Commission for review in the normal course under § 252(e)(6) of the Act with language related to Unused Transmission Media and the Combination issue unresolved, that such disputed language shall remain disputed and shall not be resolved by the Commission, and that if the Commission approves the Agreement the disputed language related to Unused Transmission Media or to the Combination issue is to be left unresolved and shall not be applied or used by the Parties.

The Parties will jointly submit the Agreement for review under the Act notwithstanding the absence of provisions resolving Unused Transmission Media and the Combination issue, and the Parties will request that the Commission in reviewing the Agreement do so without reviewing or addressing the language related to Unused Transmission Media and the Combination issue. Neither Party shall claim that the Agreement so submitted may not be approved by the Commission under Section 252, or be reviewed in federal district court pursuant to Section 252(e)(6), based on the absence of provisions resolving Unused Transmission Media and the Combination issue, or the possibility that the Agreement may subsequently be amended by the addition of such provisions or deletion of sections identifying unbundled network elements, if applicable.

If, during its review of the Agreement submitted in accordance with the foregoing, the Commission, notwithstanding the Parties' requests to the contrary, resolves all or any part of provisions related to Unused Transmission Media or unbundled network element Combinations, the Agreement shall be revised to reflect such resolution, and the revised agreement shall be submitted to the Commission for review pursuant to Section 252. The Commission's approval or rejection of the revised agreement shall then be subject to review pursuant to Section 252(e)(6). Notwithstanding such Commission action, the language related to Unused Transmission Media or to the Combination issue shall not be applied or used until after the FCC issues its New Rules.

When the FCC issues its New Rules the Agreement shall be amended to reflect the rules then applicable to unbundled network elements and Combinations, and the amended agreement shall be submitted to the Commission for review pursuant to Section 252. The Commission's approval or rejection of the amended agreement may then be subject to review.

2. **Term of Agreement**

This Agreement shall become effective in accordance with Section 23.8 (the "Effective Date"), and shall remain effective for a period of three (3) years. This Agreement shall continue in effect for consecutive one (1) year terms thereafter unless either Party gives the other Party at least ninety (90)

calendar days written notice of termination, which termination shall be effective at the end of the initial term.

3. **Termination of Agreement: Transitional Support**

3.1 Subject to any applicable restrictions and requirements contained elsewhere in this Agreement, AT&T may elect at any time to terminate this entire Agreement at AT&T's sole discretion, upon ninety (90) days prior written notice to GTE. Unless otherwise provided in this Agreement, in such case, AT&T's liability shall be limited to payment of the amounts due for Local Services, Network Elements, **Combinations** and Interconnection Services provided up to and including the date of termination. The Parties recognize that provision of uninterrupted service to customers is vital and services must be continued without interruption. Upon the termination or expiration of this Agreement, AT&T may itself provide or retain another vendor to provide comparable Local Services or, Network Elements, **or Combinations**. GTE agrees to cooperate in an orderly and efficient transition to AT&T or another vendor such that the level and quality of the Local Services and, Network Elements **and Combinations** are not degraded and to exercise reasonable efforts to assist in an orderly and efficient transition.

[Combinations]

3.2 AT&T may terminate any Local Service(s) or, Network Element(s) **or Combination(s)** provided under this Agreement upon thirty (30) days written notice to GTE, unless a different notice period or different conditions are specified for termination of such Local Service(s) or, Network Element(s) **or Combination(s)** in this Agreement, in which event such specific period and conditions shall apply.

[Combinations]

3.3 GTE will not discontinue any Unbundled Network Element or Ancillary Function **or Combination** thereof during the term of this Agreement without AT&T's written consent which consent shall not be unreasonably withheld, except (1) to the extent required by network changes or upgrades, in which event GTE will comply with the network disclosure requirements stated in the Act and the FCC's effective implementing regulations; or (2) if required by a final order of the Court, the FCC or the Commission as a result of remand or appeal of the FCC's order In the Matter of Implementation of Local Competition Provisions of the Telecommunications Act of 1996, Docket 96-98. In the event such a final order allows but does not require discontinuance, GTE shall make a proposal for AT&T's approval, and if the Parties are unable to agree, either Party may submit the matter to the Dispute resolution procedures described in Attachment 1. GTE will not discontinue any Local

Service or Combination of Local Services without providing 45 days advance written notice to AT&T, provided however, that if such services are discontinued with less than 45 days notice to the regulatory authority, GTE will notify AT&T at the same time it determines to discontinue the service. If GTE grandfathers a Local Service or combination of Local Services, GTE shall grandfather the service for all AT&T resale customers who subscribe to the service as of the date of discontinuance.

[Combinations]

3.4 Either Party may terminate this Agreement at any time by giving written notice in writing to the other Party in the event the other Party files a petition for bankruptcy, is declared bankrupt, is insolvent, makes an assignment for the benefit of creditors, or goes into liquidation or receivership. In addition, either Party may terminate this Agreement in the event of a Party's refusal or failure to pay all or any portion of any amount required to be paid to the other Party as and when due; provided however that the Party allegedly due payment (1) notifies the other Party of the amounts due, (2) utilizes the ADR process set forth in Attachment 1, (3) obtains a favorable final ruling in that process and (4) does not receive payment within thirty (30) calendar days of the final ruling. There shall be no other reason for the unilateral termination of this Agreement.

4. **Good Faith Performance**

In the performance of their obligations under this Agreement, the Parties shall act in accordance with the good faith requirements of the Act. In situations in which notice, consent, approval or similar action by a Party is permitted or required by any provision of this Agreement, (including, without limitation, the obligation of the Parties to further negotiate the resolution of new or open issues under this Agreement), such action shall not be unreasonably delayed, withheld or conditioned.

5. **Section 252 (i) Election**

GTE shall allow AT&T to elect terms other than those set forth in this Agreement to the extent required by Section 252 of the Act, final regulations thereunder and relevant court decisions.

6. **Responsibility of Each Party**

Each Party is an independent contractor, and has and hereby retains the right to exercise full control of and supervision over its own performance of its obligations under this Agreement and retains full control over the

employment, direction, compensation and discharge of all employees assisting in the performance of such obligations. Each Party will be solely responsible for all matters relating to payment of such employees, including compliance with social security taxes, withholding taxes and all other regulations governing such matters. Subject to the limitations on liability contained in this Agreement and except as otherwise provided in this Agreement, each Party shall be responsible for (i) its own acts and performance of all obligations imposed by Applicable Law in connection with its activities, legal status and property, real or personal and, (ii) the acts of its own affiliates, employees, agents and contractors during the performance of that Party's obligations hereunder.

7. **Governmental Compliance**

Except with respect to laws relating to the environment and laws relating to Intellectual Property Rights compliance with which is covered by Section 10.4, AT&T and GTE each shall comply with all Applicable Law that relates to i) its obligations under or activities in connection with this Agreement; or ii) its activities undertaken at, in connection with or relating to Work Locations. AT&T and GTE each agree to indemnify, defend (at the other Party's request) and save harmless the other, each of its officers, directors and employees from and against any losses, damages, claims, demands, suits, liabilities, fines, penalties and expenses (including reasonable attorneys' fees) that arise out of or result from its failure to so comply. Each Party will be solely responsible for obtaining from governmental authorities, building owners, other carriers, and any other persons or entities, all rights and privileges which are necessary for such Party to perform its obligations under this Agreement.

8. **Responsibility For Environmental Contamination**

8.1 Notwithstanding Section 10, GTE and AT&T shall indemnify, defend and hold harmless the other party from and against any claims (including, without limitation, third party claims for personal injury or real or personal property damage), judgments, damages (including direct and indirect damage, and punitive damages), penalties, fines, forfeitures, cost, liabilities, interest and losses or in connection with the violation or alleged violation of any applicable requirement of the presence or alleged presence of contamination arising out of the indemnifying party's acts or omissions concerning its operations at the Work Location.

8.2 GTE and AT&T agree to comply with applicable federal, state and local environmental and safety laws and regulations including U.S. Environmental Protection Agency (EPA) regulations issued under the Clean Air Act, Clean

Water Act, Resource Conservation and Recovery Act, Comprehensive Environmental Response, Compensation and Liability Act, Superfund Amendments and Reauthorization Act and the Toxic Substances Control Act and OSHA regulations issued under the Occupational Safety and Health Act of 1970 applicable to their performance under this Agreement. Each Party has the responsibility to notify the other if compliance inspections result in or citations are issued that impact any aspect of performance under this Agreement such as occurring on a LEC affected Work Location or involving CLEC potential employee exposure.

- 8.3 GTE and AT&T shall provide prompt reasonable notice to the other of known and discovered physical hazards or hazardous chemicals at any portion of an affected Work Location used by the other including, Material Safety Data Sheets (MSDSs) for materials existing or brought on site to the Work Location by such party.
- 8.4 AT&T and GTE will make available to each other their respective internal environmental control or safety procedures for review in planning work at a GTE Work Location. These practices/procedures will represent the regular work practices required to be followed by the employees and contractors for safety and environmental protection. AT&T will follow its practices unless for a specific Work Location or emergency procedure, GTE's practice provides a greater degree of safety or environmental control.
- 8.5 Any materials brought to or stored, used or remaining at a Work Location by AT&T are the property of AT&T. AT&T must demonstrate adequate emergency response capabilities for its materials used or remaining at the GTE Work Location.
- 8.6 AT&T agrees to promptly notify GTE of any third-party contamination it discovers at a GTE affected Work Location. Notification obligations to regulatory authorities shall be the responsibility of GTE to evaluate and act upon, unless AT&T is required by applicable law to directly report.
- 8.7 AT&T agrees to obtain and use its own environmental permits, if necessary for its performance under this Agreement. If GTE's permit or EPA identification number must be used, AT&T must comply with applicable GTE environmental procedures, including environmental "best management practices (BMP)" and/or selection of disposition vendors and disposal sites to the extent provided by GTE. In the event that AT&T must use GTE's vendors for waste disposal, GTE assumes all liability for such materials, and GTE agrees to indemnify AT&T for any and all claims that may arise from such waste disposal.

8.8 AT&T visitors must comply with GTE security, fire safety, safety, environmental and building practices/codes including equivalent employee training when working in GTE Work Locations, to the extent provided by GTE. GTE will, to the extent possible, supply such practices/codes to AT&T prior to AT&T's first entry into the Work Location.

8.9 GTE and AT&T shall coordinate plans or information required to be submitted to government agencies, such as emergency response plans and community reporting if applicable to their performance under this Agreement. If fees are associated with any required filing, GTE and AT&T will develop a cost sharing procedure. GTE and AT&T will determine for each Work Location which party has the lead responsibility for such filings and coordination.

8.10 Activities impacting safety or the environment of a Right of Way must be harmonized with the specific agreement and the relationship between GTE and the private land owner. This may include limitations on equipment access due to environmental conditions (e.g., wetland area with equipment restrictions).

8.11 For the purposes of this Section 8 only, the following terms have the meanings set forth in this subsection 8.11:

hazardous chemical: Means any chemical which is a health hazard or physical hazard as defined in the U.S. Occupational Safety and Health (OSHA) hazard communication standard (29 CFR 1910.1200).

third party contamination: Environmental pollution that is not generated by the LEC or CLEC but results from off-site activities impacting an affected Work Location.

8.12 **Spill and Release Notifications**

GTE and AT&T shall promptly notify the other of any spill or release of a Regulated Material at the Work Location. GTE's obligation under this Section is limited to those spills or releases likely to impact the portion of the Work Location used by AT&T, or any portion of the Work Location where AT&T personnel are reasonably expected to be present. AT&T shall be responsible for reporting any spill or release of a Regulated Material occurring as part of or in connection with its operations that must be reported to any regulatory authority. AT&T will consult with GTE prior to making such report, unless the time required for prior consultation would preclude AT&T from complying with the applicable reporting requirement.

8.13 **Management of Manhole or Vault Water**

When conducting operations in any GTE manhole or vault area, AT&T shall follow the AT&T or GTE practice/procedure that provides the greatest degree of environmental control in evaluating and managing any water present in the manhole or vault area. AT&T shall be responsible for obtaining any permit or other regulatory approval necessary for any of its operations involving the evaluation, collection, discharge, storage, disposal, or other management of water present in a GTE manhole or vault area. GTE shall not be responsible for any costs incurred by AT&T in meeting its obligations under this Section unless GTE placed or otherwise caused materials or substances to be present in the manhole or vault area.

9. **Regulatory Matters**

- 9.1 GTE shall be responsible for obtaining and keeping in effect all FCC, state regulatory commission, franchise authority and other regulatory approvals that may be required in connection with the performance of its obligations under this Agreement. AT&T shall be responsible for obtaining and keeping in effect all FCC, state regulatory commission, franchise authority and other regulatory approvals that may be required in connection with its offering of services to AT&T Customers contemplated by this Agreement. AT&T shall reasonably cooperate with GTE in obtaining and maintaining any required approvals for which GTE is responsible, and GTE shall reasonably cooperate with AT&T in obtaining and maintaining any required approvals for which AT&T is responsible.
- 9.2 Nothing in this Agreement shall be construed to deny either Party the right to file tariffs from time to time in the normal course of business. Nonetheless, each Party shall be exempt from any tariff change filed by the other Party during the term of this Agreement if such change conflicts with a price or other term of this Agreement, except to the extent that this Agreement makes the tariff item being changed determinative of such price or such other term, in which case the changed tariff shall apply prospectively.
- 9.3 If any effective legislative, regulatory, judicial or other legal actions, including a change in Applicable Law, materially affects any material terms of this Agreement, or the ability of AT&T or GTE to perform any material terms of this Agreement, such change in law shall apply immediately and the terms and conditions of this Agreement shall be applied and interpreted such that the obligations and requirements applicable to each party under this Agreement shall be consistent with such change in law. AT&T or GTE may, on thirty (30) days written notice (delivered not later than 90 days following the date on which such action has become effective) request that such term(s) be renegotiated, and the Parties agree to so negotiate in good faith such mutually acceptable new term(s). Notwithstanding the above, if the Parties do not agree on the appropriate application of any change in law to this

Agreement, either Party may pursue any remedy available to it under Applicable Law.

- 9.4 This document has been produced by GTE and AT&T pursuant to the order ("Order") of the Commission in Case Number U-11165. GTE reserves its position that this document is the functional equivalent of an order by the Commission and not an agreement entered into voluntarily by the Parties. GTE further reserves its position that the only applicable liability for violations of the obligations imposed hereby (including contractual liability) is only such liability as may be imposed by the Commission.

10. **Liability and Indemnity**

- 10.1 **Liabilities of AT&T** - AT&T's liability to GTE during any Contract Year resulting from any and all causes under this Agreement, other than as specified in Sections 7, 8, 10.3 and 10.4 below, shall not exceed an amount equal to the amount due and owing by AT&T to GTE under this Agreement during the Contract Year in which such cause accrues or arises.

- 10.2 **Liabilities of GTE** - GTE's liability to AT&T during any Contract Year resulting from any and all causes under this Agreement, other than as specified in Sections 7, 8, 10.3 and 10.4 below, shall not exceed an amount equal to any amounts due and owing by AT&T to GTE under this Agreement during the Contract Year in which such cause accrues or arises.

- 10.3 **No Consequential Damages** - EXCEPT FOR WILFUL OR INTENTIONAL MISCONDUCT, NEITHER AT&T NOR GTE SHALL BE LIABLE TO THE OTHER PARTY FOR ANY INDIRECT, INCIDENTAL, CONSEQUENTIAL, RELIANCE, OR SPECIAL DAMAGES SUFFERED BY SUCH OTHER PARTY (INCLUDING WITHOUT LIMITATION DAMAGES FOR HARM TO BUSINESS, LOST REVENUES, LOST SAVINGS, OR LOST PROFITS SUFFERED BY SUCH OTHER PARTY), REGARDLESS OF THE FORM OF ACTION, WHETHER IN CONTRACT, WARRANTY, STRICT LIABILITY, OR TORT, INCLUDING WITHOUT LIMITATION NEGLIGENCE OF ANY KIND WHETHER ACTIVE OR PASSIVE, AND REGARDLESS OF WHETHER THE PARTIES KNEW OF THE POSSIBILITY THAT SUCH DAMAGES COULD RESULT. EACH PARTY HEREBY RELEASES THE OTHER PARTY AND SUCH OTHER PARTY'S SUBSIDIARIES AND AFFILIATES, AND THEIR RESPECTIVE OFFICERS, DIRECTORS, EMPLOYEES AND AGENTS FROM ANY SUCH CLAIM. NOTHING CONTAINED IN THIS SECTION 10.3 SHALL LIMIT THE PARTIES INDEMNIFICATION OBLIGATIONS UNDER THIS AGREEMENT.

- 10.4 **Obligation to Indemnify**

Each Party shall, and hereby agrees to, defend at the other's request, indemnify and hold harmless the other Party and each of its officers, directors, employees and agents (each, an "Indemnitee") against and in respect of any loss, debt, liability, damage, obligation, claim, demand, judgment or settlement of any nature or kind, known or unknown, liquidated or unliquidated, including without limitation all reasonable costs and expenses incurred (legal, accounting or otherwise) (collectively, "Damages") arising out of, resulting from or based upon any pending or threatened claim, action, proceeding or suit by any third party (a "Claim"): (i) based upon injuries or damage to any person or property or the environment arising out of or in connection with this Agreement, that are the result of such Indemnifying Party's actions, breach of Applicable Law, or breach of representations, warranties or covenants made in this Agreement, or the actions, breach of Applicable Law or of this Agreement by its officers, directors, employees, agents and subcontractors, or (ii) for actual or alleged infringement of any patent, copyright, trademark, service mark, trade name, trade dress, trade secret or any other intellectual property right now known or later developed (referred to as "Intellectual Property Rights") to the extent that such claim or action arises from the Indemnifying Party's or the Indemnifying Party's Customer's use of the Network Elements, Ancillary Functions, **Combinations**, Local Services or other services provided under this Agreement.

[Combinations]

- 10.5 **Obligation to Defend; Notice; Co-operation** - Whenever a Claim shall arise for indemnification under this Agreement, the relevant Indemnitee, as appropriate, shall promptly notify the Indemnifying Party and request the Indemnifying Party to defend the same. Failure to so notify the Indemnifying Party shall not relieve the Indemnifying Party of any liability that the Indemnifying Party might have, except to the extent that such failure prejudices the Indemnifying Party's ability to defend such Claim. The Indemnifying Party shall have the right to defend against such liability or assertion in which event the Indemnifying Party shall give written notice to the Indemnitee of acceptance of the defense of such Claim and the identity of counsel selected by the Indemnifying Party. Except as set forth below, such notice to the relevant Indemnitee shall give the Indemnifying Party full authority to defend, adjust, compromise or settle such Claim with respect to which such notice shall have been given, except to the extent that any compromise or settlement shall prejudice the Intellectual Property Rights of the relevant Indemnitees. The Indemnifying Party shall consult with the relevant Indemnitee prior to any compromise or settlement that would affect the Intellectual Property Rights of any Indemnitee, and the relevant Indemnitee shall have the right to refuse such compromise or settlement and, at the refusing Party's or refusing Parties' cost, to take over such defense, provided that in such event the Indemnifying Party shall not be responsible

for, nor shall it be obligated to indemnify the relevant Indemnitee against, any cost or liability in excess of such refused compromise or settlement. With respect to any defense accepted by the Indemnifying Party, the relevant Indemnitee shall be entitled to participate with the Indemnifying Party in such defense to the extent the Claim requests equitable relief and also shall be entitled to employ separate counsel for such defense at such Indemnitee's expense. In the event the Indemnifying Party does not accept the defense of any indemnified Claim as provided above, the relevant Indemnitee shall have the right to employ counsel for such defense at the expense of the Indemnifying Party. Each Party agrees to cooperate and to cause its employees and agents to cooperate with the other Party in the defense of any such Claim and the relevant records of each Party shall be available to the other Party with respect to any such defense.

11. **Service Parity and Standards**

- 11.1 Notwithstanding anything in this Agreement to the contrary, GTE shall meet any service standard imposed by the FCC or by any state regulatory authority for any Local Services, Unbundled Network Elements, Ancillary Functions and Interconnection provided by GTE to AT&T for resale.
- 11.2 For any services that either Party is required by Applicable Law to provide to the other at parity, each Party shall provide services under this Agreement to the other Party that are equal in quality to that the Party provides to itself. "Equal in quality" shall mean that the service will meet the same technical criteria and performance standards that the providing Party uses within its own network for the same service at the same location under the same terms and conditions.
- 11.3 GTE and AT&T agree to implement standards to measure the quality of the Local Services and Unbundled Network Elements supplied by GTE, in particular with respect to pre-ordering, ordering/provisioning, maintenance and billing. These quality standards are described in Attachment 12. In the event of a violation of Quality Standards by either Party, which the Complaining Party alleges constitutes a breach of this Agreement, the Complaining Party may elect, subject to the procedures set forth in Attachment 1, either (1) to seek such money damages as may be available at law; or (2) to claim the penalties specified in Attachment 12, but the Complaining Party may not seek both (1) and (2) based on the same alleged breach; provided, however, that nothing in this sentence shall prevent the Complaining Party from seeking equitable relief at the same time that it pursues a claim for money damages or a claim under Attachment 12.
- 11.4 [Intentionally Left Blank]
- 11.5 [Intentionally deleted.]

12. **Customer Credit History**

12.1 With respect to customers either AT&T or GTE, as the case may be, deem delinquent in accordance with such Party's normal operating procedures, AT&T and GTE agree to make available to a designated third-party credit bureau, on a timely basis such of the following customer payment history information that is available solely from internal business records of the providing Party for each person or entity that applies for local or IntraLATA toll Telecommunications Service(s) from either carrier. Such information shall be provided on the condition that the credit bureau will only make such information available to the carrier to which the person or entity in question has applied for Telecommunication Service.

Applicants name;
Applicant's address;
Applicant's previous phone number; if any;
Amount, if any, of unpaid balance in applicant's name;
Whether applicant is delinquent on payments;
Length of service with prior local or IntraLATA toll provider;
Whether applicant had local or IntraLATA toll service terminated or suspended within the last six months with an explanation of the reason therefor; and
Whether applicant was required by prior local or IntraLATA toll provider to pay a deposit or make an advance payment, including the amount of each.

Nothing contained herein shall require either Party to undertake obligations which would subject that Party to requirements or liabilities as a consumer reporting agency under 15 U.S.C. §1681 et seq. and its implementing regulations or any similar statute, order or administrative rule of the State.

12.2 **Cooperation on Fraud Minimization** - The Parties shall cooperate with one another to investigate, minimize and take corrective action in cases of fraud. The Parties' fraud minimization procedures are to be cost effective and implemented so as not to unreasonably burden or harm one Party as compared to the other. At a minimum, such cooperation shall include, when permitted by law or regulation, providing the other Party, upon reasonable request, information concerning end users who terminate services to that Party without paying all outstanding charges, when that Party is notified that such end user seeks service from the other Party. If required, it shall be the responsibility of the Party seeking the information to secure the end user's permission (in the format required by law) to obtain the information. Although in most circumstances the end user's current telephone number may be retained by the end user when switching local service providers, if an end user has past due charges associated with the account, for which payment

arrangements have not been made with one Party, the end user's previous telephone number will not be made available to the other Party until the end user's outstanding balance has been paid.

13. **Force Majeure**

13.1 Except as otherwise specifically provided in this Agreement, neither Party shall be liable for any delay or failure in performance of any part of this Agreement caused by any condition beyond the reasonable control of the Party claiming excusable delay or other failure to perform, including acts of the United States of America or any state, territory or political subdivision thereof, acts of God or a public enemy, fires, floods, freight embargoes, earthquakes, volcanic actions, wars, or civil disturbances. If any Force Majeure condition occurs, the Party whose performance fails or is delayed because of such Force Majeure condition shall give prompt notice to the other Party, and upon cessation of such Force Majeure condition, shall give like notice and commence performance hereunder as promptly as reasonably practicable, including implementation of disaster recovery plans.

13.2 Notwithstanding subsection 1, preceding, no delay or other failure to perform shall be excused pursuant to this Section:

(i) by the acts or omission of a Party's subcontractors, material men, suppliers or other third persons providing products or services to such Party unless such acts or omissions are themselves the product of a Force Majeure condition, and

(ii) unless such delay or failure and the consequences thereof are beyond the reasonable control and without the fault or negligence of the Party claiming excusable delay or other failure to perform.

14. **Certain State and Local Taxes**

Any state or local excise, sales, or use taxes (excluding any taxes levied on income) resulting from the performance of this Agreement shall be borne by the Party upon which the obligation for payment is imposed under applicable law, even if the obligation to collect and remit such taxes is placed upon the other Party. The collecting Party shall charge and collect from the obligated Party, and the obligated Party agrees to pay to the collecting Party, all applicable taxes, except to the extent that the obligated Party notifies the collecting Party and provides to the collecting Party appropriate documentation that qualifies the obligated Party for a full or partial exemption. Any such taxes shall be shown as separate items on applicable billing documents between the Parties. The obligated Party may contest the same in good faith, at its own expense, and shall be entitled to the benefit of any refund or recovery, provided that such Party shall not permit any lien to exist on any asset of the other Party by reason of the contest. The collecting Party

shall cooperate in any such contest by the other Party, provided that the contesting Party shall pay the reasonable expenses of the collecting Party for any such cooperative activities.

15. **Alternative Dispute Resolution**

All Disputes arising under this Agreement or the breach hereof, except those arising pursuant to Attachment 6, Connectivity Billing, shall be resolved according to the procedures set forth in Attachment 1. Disputes involving matters subject to the Connectivity Billing provisions contained in Attachment 6, shall be resolved in accordance with the Billing Disputes section of Attachment 6. In no event shall the Parties permit the pendency of a Dispute to disrupt service to any customer of any Party contemplated by this Agreement except in the case of default and termination of this Agreement pursuant to Section 3.4. The foregoing notwithstanding, neither this Section 15 nor Attachment 1 shall be construed to prevent either Party from seeking and obtaining temporary equitable remedies, including temporary restraining orders.

16. **Notices**

Any notices or other communications required or permitted to be given or delivered under this Agreement shall be in hard-copy writing (unless otherwise specifically provided herein) and shall be sufficiently given if delivered personally or delivered by prepaid overnight express service or certified mail, return receipt requested or by facsimile (followed by a hard copy delivered by U.S. Mail or another method specified herein) to the following (unless otherwise specifically required by this Agreement to be delivered to another representative or point of contact):

If to AT&T:

Charlotte I. Field
Director, AT&T
Room 10-01
1875 Lawrence Street
Denver, Colorado 80202
Facsimile Number: 303-298-6557

and

Joyce Beasley
General Attorney, AT&T
Room 3159D1
295 North Maple Ave.

Basking Ridge, New Jersey 07920
Facsimile Number: 908-953-8360

If to GTE:

GTE North Incorporated
Attention: Assistant Vice President/Associate General Counsel
Business Development and Integration
600 Hidden Ridge - HQEO3J43
Irving, TX 75038
Telephone Number: 972-718-6361
Facsimile Number: 972-718-3404

and

GTE North Incorporated
Attention: Director – Wholesale Contract Compliance
Network Services
700 Hidden Ridge – HQW02H20
Irving, TX 75038
Telephone Number: 972-718-5988
Facsimile Number: 972-718-1519

Either Party may unilaterally change its designated representative and/or address for the receipt of notices by giving seven (7) days' prior written notice to the other Party in compliance with this Section. Any notice or other communication shall be deemed given when received.

17. **Confidentiality and Proprietary Information**

17.1 For the purposes of this Agreement, "Confidential Information" means confidential or proprietary technical or business information, in written or tangible form, given by the Discloser to the Recipient that is stamped, labelled, or otherwise designated as "Proprietary" or "Confidential" or that contains other words or symbols clearly indicating that the information is intended to be secure from public disclosure. "Confidential Information" also includes information that is intentionally provided or disclosed orally or visually if it is identified as proprietary or confidential when provided or disclosed and is summarized in a writing so marked and delivered within ten (10) days following such disclosure. "Confidential Information" also includes information that is observed or learned by one Party while it is on the premises (including leased collocation space) of the other Party.

Notwithstanding the foregoing, all orders for Local Services or, Network Elements **or Combinations** placed by AT&T pursuant to this Agreement, and information that would constitute Customer Proprietary Network Information of AT&T Customers pursuant to the Act and the rules and regulations of the FCC and Recorded Usage Data as described in Attachment 7, whether disclosed by AT&T to GTE or otherwise acquired by GTE in the course of the performance of this Agreement, shall be deemed Confidential Information of AT&T for all purposes under this Agreement whether or not specifically marked or designated as confidential or proprietary.

[Combinations]

- 17.2 For the period set forth in Section 17.6, except as otherwise specified in this Agreement, the Recipient agrees (a) to use it only for the purpose of performing under this Agreement, (b) to hold it in confidence and disclose it to no one other than its employees or agents or consultants having a need to know for the purpose of performing under this Agreement, and (c) to safeguard it from unauthorized use or disclosure with at least the same degree of care with which the Recipient safeguards its own Confidential Information. Any agent or consultant must have executed a written agreement of non-disclosure and non-use comparable in scope to the terms of this Section 17 which agreement shall be enforceable by the Discloser.
- 17.3 The Recipient may make copies of Confidential Information only as reasonably necessary to perform its obligations under this Agreement. All such copies shall be subject to the same restrictions and protections as the original and shall bear the same copyright and proprietary rights notices as are contained on the original.
- 17.4 The Recipient agrees to return to the Discloser all Confidential Information received in tangible form from the Discloser, including any copies made by the Recipient, within thirty (30) days after a written request is delivered to the Recipient, or to destroy or erase all such Confidential Information and certify as to such event, except for Confidential Information that the Recipient reasonably requires to perform its obligations under this Agreement or as otherwise required by applicable law. If either Party loses or makes an unauthorized disclosure of the other Party's Confidential Information, it shall notify such other Party as soon as is reasonably practicable after the loss is discovered and use reasonable efforts to retrieve the lost or wrongfully disclosed information.
- 17.5 The Recipient shall have no obligation to safeguard Confidential Information: (a) which was in the possession of the Recipient free of restriction on use or disclosure prior to its receipt from the Discloser; (b) after it becomes publicly known or available through no breach of this Agreement or other restriction on

use or disclosure by the Recipient; (c) after it is rightfully acquired by the Recipient free of restrictions on its use or disclosure; or (d) after it is proven to be independently developed by personnel of the Recipient to whom the Discloser's Confidential Information had not been previously disclosed. In addition, either Party shall have the right to disclose Confidential Information to any mediator, arbitrator, state or federal regulatory body, the Department of Justice or any court in the conduct of any mediation, arbitration or approval of this Agreement subject to the requirements concerning notice and other measures specified in the last sentence of this Subsection. Additionally, the Recipient may disclose Confidential Information if so required by law, a court of competent jurisdiction, or governmental or administrative agency, so long as the Discloser has been notified of the requirement promptly after the Recipient becomes aware of the requirement, but prior to such disclosure and so long as the Recipient undertakes all lawful measures to avoid disclosing such information until Discloser has had reasonable time to seek a protective order and Discloser complies with any protective order that covers the Confidential Information to be disclosed.

- 17.6 Each Party's obligations with respect to Confidential Information disclosed prior to expiration or termination of this Agreement shall expire three (3) years from the date of receipt of the initial disclosure, regardless of any termination of this Agreement prior to such expiration date; provided that the duties with respect to Confidential Information that is software, protocols and interfaces shall expire fifteen (15) years from the date of the initial disclosure.
- 17.7 Except as otherwise expressly provided elsewhere in this Agreement, no license is hereby granted under any patent, trademark, copyright or other Intellectual Property Right, nor is any such license implied, solely by virtue of the disclosure of any Confidential Information.
- 17.8 Each Party agrees that the Discloser would be irreparably injured by a breach of this Agreement by the Recipient or its representatives and that the Discloser shall be entitled to seek equitable relief, including injunctive relief and specific performance, in the event of any breach of the provisions of this Section 17. Such remedies shall not be deemed to be the exclusive remedies for a breach of this Section 17, but shall be in addition to all other remedies available at law or in equity.

18. **Branding**

AT&T may, at its option, use the Network Elements, **Combinations** and Local Services provided in accordance with this Agreement to provide to its customers services branded as AT&T. Except as otherwise provided in this Agreement or specified in a separate writing by AT&T, AT&T shall provide the exclusive interface to AT&T Customers in connection with the marketing or

offering of AT&T services. When a GTE technical representative goes to a customer premise on behalf of AT&T, in the event the representative has contact with the customer, the representative will indicate to the customer that he or she works for GTE but is at the customer premise on behalf of AT&T regarding AT&T service. If the customer is not at the premise at the time that the technical representative is at the premise, GTE agrees to deliver generic material or documents to the customer, and the representative will write AT&T's name on the document or material left for the customer. GTE personnel acting on behalf of AT&T will not discuss, provide, or leave information or material relative to GTE's services and products.

[Combinations]

- 18.1 Operator Services and Directory Assistance provided by GTE to AT&T local service customers under this Agreement will, upon AT&T's request, be branded exclusively as AT&T services, where technically feasible. GTE will perform the necessary software upgrades to allow for rebranding of its Operator Services and Directory Assistance in AT&T's name on a switch by switch basis, subject to capability and capacity limitations; until those upgrades have been completed, GTE will provide rebranded services through alternate means to the extent technically feasible. Such alternate means may include, for example, provisioning of additional trunks necessary to accommodate AT&T's rebranding requests. If it is not technically feasible for GTE to provide Operator Services and Directory Assistance as rebranded services, then GTE will provide such services to AT&T's local service customers without any branding, if allowed by state laws and regulations. Live operators handling Operator Services and Directory Assistance calls from AT&T local service customers will identify themselves as AT&T operators; where such rebranding is not technically feasible, such live operator response will be provided on an unbranded basis. AT&T shall pay GTE's costs, if any, pursuant to the pricing standards of Section 252(d) of the Act and in such amounts or levels as determined by the Commission for implementation of such branding.

19. **Directory Listings and Directory Distribution**

GTE shall offer the following to AT&T:

- 19.1 **Directory Listings (White Pages)** - A basic listing for each AT&T Customer shall be included in the GTE white pages directory for such AT&T Customer's specific geographic area at no charge to AT&T or AT&T's Customers. Where an AT&T Customer has two numbers for a line due to the implementation of interim Local Number Portability, the second number shall be considered part of the White pages basic listing. Other listings that are made available to GTE Customers (e.g. additional listings, non-published status, foreign listings,

etc.) will be made available to AT&T Customers on the same rates, terms and conditions as available to GTE Customers. AT&T Customer Government listings will be listed in the same manner as GTE Customer Government listings.

- 19.2 **Directory Listings (Yellow Pages)** GTE will provide AT&T Customers with the same yellow page services on the same terms and conditions as those provided to GTE Customers. GTE will provide each AT&T Customer within the geographical area covered by the yellow pages directory a basic listing in GTE "yellow pages" under the classified heading that most accurately reflects the primary nature of the AT&T Customer's business at no charge to AT&T or AT&T Customers for this listing. GTE will supply AT&T with a list of authorized classified headings and will notify AT&T of any changes to such headings. AT&T agrees to supply GTE, on a regularly scheduled basis and in the format mutually agreed between AT&T and GTE, with a classified heading assignment for each AT&T Customer who wishes to receive this listing. GTE shall provide AT&T with monthly schedules (for a rolling twelve (12) month period) for Yellow Pages publications in the State.
- 19.3 **Listing Information -** AT&T agrees to supply GTE, on a regularly scheduled basis and in the format mutually agreed between AT&T and GTE, all listing information for AT&T Customers who wish to be listed in the white or yellow pages of the GTE published directory for that subscriber area. Listing information will consist of names, addresses (including city and ZIP code where provided in that directory) and telephone numbers. GTE shall employ the listing information for the production of GTE-published white and yellow page directories. Listing inclusion in a given directory will be in accordance with directory configuration, scope and schedules established by GTE which are applicable to all GTE entities. GTE shall obtain AT&T's prior written approval for the use of AT&T Customers' listings for any other purpose. GTE will not sell or license, nor allow any third party, the use of AT&T subscriber listing and GTE will not disclose non-listed name or address information for any purpose without the prior written consent of AT&T, which shall not be unreasonably withheld. GTE will charge AT&T a reasonable service bureau extraction fee for all third party translations and AT&T will be free to establish its own fees for direct billing the third parties.
- 19.4 **Directory Distribution -** Initial directories will be provided to AT&T Customers for each AT&T Customer's specific geographic region on the same basis as GTE Customers within the same directory area. More specifically, GTE will not charge AT&T or AT&T Customers for annual distribution of directories. GTE will provide secondary distributions of directories (e.g. a new customer, requests for additional copies) to AT&T Customers at the same price that GTE is charged for secondary distribution by GTE Directories. AT&T shall pay GTE Directories for such secondary distributions based on

GTE's agreement that the secondary distribution costs will be excluded from GTE's cost studies and resulting avoided cost discounts and prices for unbundled elements. Timing of such delivery and the determination of which Telephone Directories shall be delivered (by customer address, NPA/NXX or other criteria), and the number of Telephone Directories to be provided per customer, shall be provided under the same terms that GTE delivers Telephone Directories to GTE Customers. AT&T will supply GTE in a timely manner with all required subscriber mailing information, including non-listed and non-published subscriber mailing information, to enable GTE to perform its distribution responsibilities.

- 19.5 **Critical Customer Contact Information** - GTE will list in the information pages of its directories at no charge to AT&T, AT&T's critical customer contact information for business and residential customers regarding emergency services, billing, sales and service information, repair service and AT&T's logo. GTE shall list Competitive Local Exchange Carrier critical customer contact information on an alphabetical basis.
- 19.6 GTE shall also include, in the customer call guide page(s) of each Telephone Directory, up to four full pages of consolidated space for the inclusion of information about AT&T products and services, including addresses and telephone numbers for AT&T customer service. The form and content of such customer information shall be provided by AT&T to GTE and shall be subject to GTE review and approval, which approval shall not be unreasonably withheld. AT&T agrees to pay a price per page to be determined by GTE Directories, provided that such price shall be non-discriminatory to GTE and AT&T.
- 19.7 GTE shall, at no charge to AT&T, make available recycling services for Telephone Directories to AT&T Customers under the same terms and conditions that GTE makes such services available to its own local service customers.
- 19.8 Notwithstanding anything to the contrary contained herein, GTE may terminate this Section 19 as to a specific GTE exchange in the event that GTE sells or otherwise transfers the exchange to an entity other than a GTE Affiliate. GTE shall provide AT&T with at least ninety (90) days' prior written notice of such termination, which shall be effective on the date specified in the notice. Notwithstanding termination as to a specific exchange, this Section 19 shall remain in full force and effect in the remaining exchanges.

19.9 Notwithstanding the termination of this Section 19, the Parties' obligations with respect to any directories whose annual publication cycle has begun prior to the effective date of termination shall survive such termination. For example, if a Party terminates this Section 19 effective as of June 30, 1998, the Parties' survival obligations shall apply as follows:

Exchange	Beginning of Publication Cycle	Expiration of Obligations
1	January 1, 1998	December 31, 1998
2	June 1, 1998	May 31, 1999
3	August 1, 1998	June 30, 1999

a publication cycle begins the day following the listing activity close date for the current year's publication.

19.10 Directory Listing criteria shall be specified by GTE. GTE shall provide any changes to its Directory Listing Criteria thirty (30) days in advance of such changes becoming effective. The Directory Listing criteria shall include:

19.10.1 Classified heading information;

19.10.2 Rules for White Pages and Yellow Pages listings (e.g., eligibility for free Yellow Pages listing, space restrictions, unlisted and unpublished listings, abbreviated listings, foreign listings, and heading requirements);

19.10.3 Identification of Enhanced White Pages and Enhanced Yellow Pages listings available;

19.10.4 Publication schedules for White Pages and Yellow Pages;

19.10.5 Identification of which Telephone Directories are provided to which customers by customer address, NPA/NXX or other criteria;

19.10.6 Telephone Directory delivery schedules;

19.10.7 Restrictions, if any, on number of Telephone Directories provided at no charge to customer;

19.10.8 Processes and terms and conditions for obtaining foreign Telephone Directories from GTE; and

19.10.9 Geographic coverage areas of each Telephone (by municipality and NPA/NXX).

20. **Directory Assistance Listing Information**

20.1 GTE shall include in its directory assistance database all directory assistance listing information, which consists of name and address ("DA Listing Information") for all AT&T Customers, including those with nonpublished and unlisted numbers.

GTE shall provide to AT&T, at AT&T's request, for purposes of AT&T providing AT&T-branded directory assistance services to its local customers, within thirty (30) days after the Effective Date, all published GTE DA Listing Information via magnetic tape delivered within twenty-four (24) hours of preparation, at the rate specified in Attachment 14. Changes to the DA Listing Information shall be updated on a daily basis through the same means used to transmit the initial list. DA Listing Information provided shall indicate whether the customer is a residence or business customer.

20.2 Neither Party will release, sell, or license DA Listing Information that includes the other Party's end user information to third parties without the other Party's approval. The other Party shall inform the releasing Party if it desires to have the releasing Party provide the other Party's DA Listing Information to the third party, in which case, the releasing Party shall provide the other Party's DA Listing Information at the same time as the releasing Party provides the releasing Party's DA Listing Information to the third party. The rate to be paid by the releasing Party to the other Party for such sales shall be negotiated on a case-by-case basis.

21. **Busy Line Verification and Busy Line Verification Interrupt**

Prior to the exchange of traffic under this Agreement, each Party shall establish procedures whereby its operator bureau will coordinate with the operator bureau of the other Party to provide Busy Line Verification ("BLV") and Busy Line Verification Interrupt ("BLVI") services on calls between their respective end users. Each Party shall route BLV and BLVI inquiries over separate inward operator services trunks. Each Party's operator assistance bureau will only verify and/or interrupt the call and will not complete the call of the end-user initiating the BLV or BLVI. Each Party shall charge the other for the BLV and BLVI services on a bill-and-keep basis.

22. **Number Assignment**

22.1 GTE shall allocate Central Office Codes, i.e. NXXs, in a neutral manner at parity with itself in those LATAs where GTE is the number administrator. GTE shall not charge a fee for the allocation of NXXs to AT&T for any costs including, but not limited to, programming expenses incurred by GTE in their role as number administrator; provided, however, that when responsibility for number assignment is transferred to a neutral third party, GTE shall charge a

fee for such services to recover costs incurred that is consistent with the applicable rules and regulations for such.

- 22.2 GTE shall process all AT&T NXX requests in a timely manner as per the ICCF Code Assignment Guidelines and will provide numbers in any NPA/NXX associated with a terminating line within the boundaries of an LSO, in those LATAs where GTE is the number administrator.
- 22.3 GTE, during the interim period, will maintain its current process of notifying public utility commissions and state regulatory bodies of plans for NPA splits and code relief.
- 22.4 GTE shall treat as confidential, and solely for use in its role as Code Administrator and for no other purpose, any and all information received from AT&T regarding NPA/NXX forecasts. This information shall be used only for the purposes of code administration, e.g. NPA code relief studies.
- 22.5 GTE shall participate in the transition of its code administration responsibilities to a neutral third party and will notify AT&T if there are not sufficient numbers to meet the forecasted requirements of AT&T.
- 22.6 GTE shall provide AT&T with a file, or files, containing a street address/LSO cross reference indicating which LSO serves the cross referenced street address.

23. **Miscellaneous**

- 23.1 **Delegation or Assignment** - Any assignment by either Party of any right, obligation, or duty, in whole or in part, or of any interest, without the written consent of the other Party shall be void, except that either Party may assign all of its rights, and delegate its obligations, liabilities and duties under this Agreement, either in whole or in part, to any entity that is, or that was, an Affiliate of that Party without consent, but with written notification, provided that in the case of AT&T, such Affiliate is a certified provider of local dial-tone service in the State to the extent such State requires such certification. The effectiveness of an assignment shall be conditioned upon the assignee's assumption of the rights, obligations, and duties of the assigning Party.
- 23.2 **Subcontracting** - GTE may subcontract the performance of any obligation under this Agreement without the prior written consent of AT&T, provided that GTE shall remain fully responsible for the performance of this Agreement in accordance with its terms, including any obligations it performs through subcontractors, and GTE shall be solely responsible for payments due its subcontractors. No contract, subcontract or other Agreement entered into by either Party with any third party in connection with the provision of Local Services or Network Elements hereunder shall provide for any indemnity,

guarantee or assumption of liability by, or other obligation of, the other Party to this Agreement with respect to such arrangement, except as consented to in writing by the other Party. No subcontractor shall be deemed a third party beneficiary for any purposes under this Agreement.

- 23.3 [Intentionally deleted.]
- 23.4 **Binding Effect** - This Agreement shall be binding on and inure to the benefit of the respective successors and permitted assigns of the Parties.
- 23.5 **Nonexclusive Remedies** - Except as otherwise expressly provided in this Agreement, each of the remedies provided under this Agreement is cumulative and is in addition to any remedies that may be available at law or in equity.
- 23.6 **No Third-Party Beneficiaries** - Except as specifically set forth in Section 10.4 and 10.5, this Agreement does not provide and shall not be construed to provide third parties with any remedy, claim, liability, reimbursement, cause of action, or other privilege.
- 23.7 **Referenced Documents** - Whenever any provision of this Agreement refers to a technical reference, technical publication, AT&T Practice, GTE Practice, any publication of telecommunications industry administrative or technical standards, or any other document expressly incorporated into this Agreement, it will be deemed to be a reference to the most recent version or edition (including any amendments, supplements, addenda, or successors) of such document that is in effect at the time of the execution of this Agreement, and will include the most recent version or edition (including any amendments, supplements, addenda, or successors) of each document incorporated by reference in such a technical reference, technical publication, AT&T Practice, GTE Practice, or publication of industry standards.
- 23.8 **Regulatory Agency Control** - This Agreement shall at all times be subject to changes, modifications, orders, and rulings by the FCC and/or the applicable state utility regulatory commission to the extent the substance of this Agreement is or becomes subject to the jurisdiction of such agency. This Agreement is subject to approval of the Commission in accordance with Section 252 of the Act. This Agreement shall not become effective until five (5) Business Days after receipt by the Parties of written notice of such approval. "Business Day" shall mean Monday through Friday, except for holidays on which the U.S. Mail is not delivered. GTE reserves its position that the prices contained in this Agreement do not afford GTE the opportunity to recover its historic costs, and as such, contrary to the Commission's determinations, the Commission should not approve this Agreement and the Agreement should not become effective until such time as the Commission has (1) put in place a mechanism to provide GTE the opportunity to recover

its historic costs, and (2) established a universal service system that is competitively neutral.

- 23.9 **Governing Law** - This Agreement shall be governed by and construed in accordance with the Act and the FCC's effective Rules and Regulations, and applicable state law to the extent such state law is not inconsistent with the Act, or the FCC's effective Rules and Regulations.
- 23.10 **Publicity and Advertising** - Any news release, public announcement, advertising, or any form of publicity pertaining to this Agreement, or the provision of Local Services, Unbundled Network Elements, Ancillary Functions or Interconnection Services pursuant to it, or association of the Parties with respect to provision of the services described in this Agreement shall be subject to prior written approval of both GTE and AT&T. Neither Party shall publish or use any advertising, sales promotions or other publicity materials that use the other Party's logo, trademarks or service marks without the prior written approval of the other Party.
- 23.11 **Amendments or Waivers** - Except as otherwise provided in this Agreement, no amendment or waiver of any provision of this Agreement, and no consent to any default under this Agreement, shall be effective unless the same is in writing and signed by an officer of the Party against whom such amendment, waiver or consent is claimed. In addition, no course of dealing or failure of a Party strictly to enforce any term, right or condition of this Agreement shall be construed as a waiver of such term, right or condition. By entering into this Agreement, neither Party waives any right granted to it pursuant to the Act.
- 23.12 **Severability** - If any term, condition or provision of this Agreement is held by a governmental body of competent jurisdiction be invalid or unenforceable for any reason, such invalidity or unenforceability shall not invalidate the entire Agreement. The Agreement shall be construed as if it did not contain the invalid or unenforceable provision or provisions, and the rights and obligations of each Party shall be construed and enforced accordingly.
- 23.13 **Entire Agreement** - This Agreement, which shall include the Attachments, Appendices and other documents referenced herein, constitutes the entire Agreement between the Parties concerning the subject matter hereof and supersedes any prior agreements, representations, statements, negotiations, understandings, proposals or undertakings, oral or written, with respect to the subject matter expressly set forth herein.
- 23.14 **Survival of Obligations** - Any liabilities or obligations of a Party for acts or omissions prior to the cancellation or termination of this Agreement; any obligation of a Party under the provisions regarding indemnification, Confidential Information, limitations on liability, and any other provisions of

this Agreement which, by their terms, are contemplated to survive (or to be performed after) termination of this Agreement, shall survive cancellation or termination thereof.

- 23.15 **Executed in Counterparts** - In the event that the Commission requires that this Agreement be executed by each of the Parties, this Agreement may be executed in any number of counterparts, each of which shall be deemed an original; but such counterparts shall together constitute one and the same instrument.
- 23.16 **Headings of No Force or Effect** - The headings of Articles and Sections of this Agreement are for convenience of reference only, and shall in no way define, modify or restrict the meaning or interpretation of the terms or provisions of this Agreement.
- 23.17 **Trademarks and Trade Names** - Except as specifically set out in this Agreement, nothing in this Agreement shall grant, suggest, or imply any right, license or authority for one Party to use the name, trademarks, service marks, or trade names of the other Party for any purpose whatsoever.
- 23.18 **Notice of Network and Technology Changes** - GTE shall establish quarterly reviews of network and technologies plans. GTE shall notify AT&T at least six (6) months in advance of changes that would impact AT&T's provision of service.
- 23.19 **Technical References** -
- 23.19.1 This Agreement contains technical references for unbundled network elements, ancillary services, and interconnection facilities. Due to the manner in which individual equipment manufacturers have chosen to implement industry standards into the design of their products, along with differing vintages of individual facility components and the presence of embedded technologies that pre-date current technical references, individual facility components deployed within GTE's network need not meet or adhere to, and may differ significantly from, the technical references included in this Agreement. Nothing in this Agreement shall prohibit GTE from improving or otherwise modifying its network, including, but not limited to, improvements or modifications to individual facility components, and such improvements or modifications need not meet or adhere to any of the technical references cited throughout this Agreement.
- Accordingly, the Parties acknowledge and agree that the technical references contained in this Agreement shall be used only by them as a reference for their own internal network and operational service planning for unbundled network elements, ancillary services, and interconnection facilities. The technical references contained in this Agreement shall not, however, be

interpreted to require GTE to satisfy any of its obligations set forth in this Agreement in accordance with any specification set forth therein.

- 23.19.2 AT&T may request technical information related to any unbundled network element, ancillary service, or interconnection facility offered pursuant to this Agreement. GTE will supply such technical information pursuant to the processes and procedures currently in place between the Parties for answering similar requests for technical information with regard to interLATA access. The Parties agree that GTE will provide technical information belonging to GTE that GTE designates as proprietary and that GTE is otherwise authorized to release pursuant to the nondisclosure provisions of this Agreement. In the event GTE's supplier has designated such information as proprietary, GTE will assist AT&T in seeking the supplier's consent to review such technical information. The number and nature of requests shall be reasonable. If at such time as the above processes and procedures have been utilized by the Parties for a period no shorter than ninety (90) days after receipt by the applicable Party of an initial request, and upon receipt of notice from either Party from the other Party that the Party giving notice deems the existing processes and procedures unsatisfactory, the Parties shall negotiate new processes and procedures and the existing processes and procedures shall no longer apply.
- 23.20 Any figures and/or schematics used throughout this Agreement, including, but not limited to, the figures and/or schematics used in Attachment 2 to this Agreement, are for the convenience of reference only, and shall in no way define, modify or restrict the meaning or interpretation of the terms or provisions of this Agreement.

PART I LOCAL SERVICES RESALE

24. Telecommunications Services Provided for Resale

Upon request by AT&T in accordance with Section 25.1 and subject to the restrictions contained in Section 25.3 hereunder, GTE shall make available to AT&T at the applicable rate set forth in Attachment 14, any Telecommunications Service that GTE currently offers or may hereafter offer at retail to subscribers that are not telecommunications carriers. GTE shall also provide to AT&T local service customers of each such Telecommunications Service the service support functions GTE provides to its own local service customers of the same Telecommunications Service. Such Telecommunications Services and service support functions (preordering, ordering, provisioning, maintenance, repair and billing) provided by GTE pursuant to this Section are collectively referred to as "Local Services."

25. General Terms and Conditions for Resale

25.1 Ordering

- 25.1.1 Orders for resale of Local Services will be placed utilizing a standard Local Service Request ("LSR") form. A complete and accurate LSR must be provided by AT&T before a request can be processed; provided, however, that immaterial deviations or omissions in the LSR will not prevent an order from being processed. Each Party shall transfer the customer's service features and functionalities "as is" to the other Party when requested by a customer. For purposes of this Section 25, an "as is transfer" is the transfer of all the telecommunications services and features available for resale that are currently being provided for the specified account without the requirement of a specific enumeration of the services and features on the LSR.
- 25.1.2 A Letter of Authorization ("LOA") will be required before Local Services will be provided for resale to a subscriber that currently receives local exchange service from GTE or from a local service provider other than AT&T. Such LOA may be a blanket letter of authorization (Blanket LOA) or such other form as agreed upon by AT&T and GTE. When a Blanket LOA has been provided by AT&T, GTE shall not require an additional disconnect order, LOA or other writing from a customer, or another LEC, in order to process an order for Local Service. Each Party will provide the capability for customers to retain their current phone number in the event that they change local service providers to the extent technically feasible, allowing them to retain all existing features and functionalities.
- 25.1.3 GTE shall include an AT&T Customer's listing in its Directory Assistance database as part of the Local Service Request ("LSR") process. GTE will honor AT&T Customer's preferences for listing status, including non-published and unlisted, as noted on the LSR and will enter the listing in the

GTE database which is used to perform Directory Assistance functions as it appears on the LSR.

- 25.1.4 GTE shall accept requests for a change in the primary interexchange carrier of a local exchange customer of AT&T only from AT&T.

25.2 **Pricing**

The prices to be charged to AT&T for Local Services under this Agreement are set forth in Part V of this Agreement.

25.3 **Restrictions on Resale**

To the extent consistent with the applicable rules and regulations of the FCC and the Commission, AT&T may resell all GTE Local Services as defined in GTE's tariffs. The following restrictions shall apply to the resale of Local Services, as described in Section 24 of this Agreement by AT&T: (i) AT&T shall not resell to one class of customers a Local Service that is offered by GTE only to another class of customer; (ii) AT&T shall not resell GTE promotional offerings that are made available to GTE end users for a period of ninety (90) days or less; and (iii) AT&T shall only sell "grandfathered" Local Services to those end-user customers who had previously ordered them from GTE and only at the same service location.

- 25.4 [Intentionally deleted]

25.5 **Dialing and Service Parity**

- 25.5.1 GTE will provide the same dialing parity to AT&T Customers as similarly-situated GTE Customers, such that, for all call types, an AT&T Customer is not required to dial any greater number of digits than a similarly-situated GTE Customer; provided however with respect to intra-LATA dialing, GTE shall provide dialing parity to AT&T customers in the State in accordance with the provisions and schedule established by the Commission.
- 25.5.2 GTE will provide service levels for Local Services for resale that are equal to service levels for similarly-situated GTE Customers, such that there is no loss of features or functionalities including, but not limited to: same dial tone and ringing; same capability for either dial pulse or touch tone recognition; flat and measured services; speech recognition as available; same extended local free calling area; 1+ IntraLATA toll calling; InterLATA toll calling and international calling; 500, 700, 800, 900, 976 and Dial Around (10xxx) Services; restricted collect and third number billing; all available speeds of analogue and digital private lines; off-premise extensions; CENTRANET and ISDN.

25.6 **Changes in Retail Service**

GTE will notify AT&T of proposed new retail services or modifications to existing retail services forty-five (45) days prior to the expected date of regulatory approval of the new or modified services. If new services or modifications are introduced with less than forty-five (45) days notice to the regulatory authority, GTE will notify AT&T at the same time it determines to introduce the new or modified service. With respect to changes in prices for existing retail services or related resale rates, GTE will notify AT&T at the same time as GTE begins internal implementation efforts (i.e., at least at the time that GTE's Product Management Committee is notified of the proposed change) or obtains internal approval to make the price change, whichever is sooner.

26. **Requirements for Specific Services**

26.1 [Intentionally deleted]

26.2 CLASS/LASS and Custom Features Requirements

AT&T may purchase the entire set of CLASS/LASS and Custom features and functions, or a subset of any one or any combination of such features, on a customer-specific basis, without restriction on the minimum or maximum number of lines or features that may be purchased for any one level of service, provided such CLASS/LASS and Custom features are available to GTE Customers served by the same GTE Central Office. GTE shall provide to AT&T a list of CLASS/LASS and Custom features and functions within ten (10) business days of the Effective Date and shall provide updates to such list when new features and functions become available. GTE shall provide to AT&T a list of all services, features, and products including a definition of the service (by specific reference to the appropriate tariff sections) and how such services interact with each other. GTE shall provide features and services by street address guide and by switch. All features shall be at least at parity with the GTE service offering.

26.3 This Section intentionally left blank.

26.4 **Intercept and Transfer Service**

GTE shall provide intercept and transfer service to AT&T for AT&T Customers on the same basis and for the same length of time as such service is available to similarly-situated GTE Customers. To that end, when an end-user customer transfers service from GTE to AT&T, or from AT&T to GTE, and does not retain its original telephone number, the Party formerly providing service to the end user will provide, upon request, a referral announcement

on the original telephone number. The announcement will provide the new number of the customer.

26.5 E911/911 Services

GTE shall provide to AT&T, for AT&T Customers, E911/911 call routing to the appropriate PSAP. AT&T shall provide AT&T Customer information to GTE, and GTE shall validate and provide AT&T Customer information to the PSAP. GTE shall use its service order process to update and maintain, on the same schedule that it uses for its end users, the AT&T Customer service information in the ALI/DMS (Automatic Location Identification/Location Information Database Management System) used to support E911/911 services, pursuant to National Emergency Number Agency (NENA) standards. AT&T shall have the right to verify the accuracy of the information regarding AT&T Customers in the ALI database.

26.6 Telephone Relay Service

GTE will provide the following information to AT&T at no additional charge:

- (i) information concerning a customer's qualification for Telephone Relay Service (TRS) on the Customer Service Record (CSR) when that customer chooses AT&T for local service; and
- (ii) all usage billing information which GTE receives from a provider of TRS for TRS usage by an AT&T Customer.

26.7 Voice Mail Related Services

Nothing in this Agreement shall limit the right of AT&T to purchase features capabilities of voice mail services in accordance with GTE's tariffs. In addition, nothing in this Agreement shall limit the right of AT&T to combine features capabilities of voice mail services purchased in accordance with GTE's tariffs with any Local Services purchased for resale in accordance with this Agreement.

26.8 Voluntary Federal Customer Financial Assistance Programs

Local Services provided to low-income subscribers, pursuant to requirements established by the appropriate state or federal regulatory body, include programs such as Voluntary Federal Customer Financial Assistance Programs, such as Lifeline, and Link-up America (collectively referred to as "Voluntary Federal Customer Financial Assistance Programs") and Directory Assistance - Exempt. When a GTE Customer eligible for these services chooses to obtain Local Service from AT&T, GTE shall forward to AT&T on the Customer Service Record information regarding such customer's eligibility to participate in such programs. If GTE under the applicable laws of the State cannot provide the CSR to AT&T, GTE shall otherwise inform AT&T of such customer's eligibility.

27. **Advanced Intelligent Network**

- 27.1 GTE will provide AT&T access to the GTE Service Creation Environment (SCE) to design, create, test, deploy and provision AIN-based features, equivalent to the access GTE provides to itself, providing that security arrangements can be made. AT&T requests to use the GTE SCE will be subject to request, review and testing procedures to be agreed upon by the parties.
- 27.2 When AT&T utilizes GTE's Local Switching network element and requests GTE to provision such network element with a Currently Available AIN trigger, GTE will provide access to the appropriate AIN Call Related Database for the purpose of invoking either a GTE AIN feature or an AT&T developed AIN feature described in 27.1, above.
- 27.3 When AT&T utilizes its own local switch, GTE will provide access to the appropriate AIN Call Related Database for the purpose of invoking either a GTE AIN feature or an AT&T developed AIN feature described in 27.1, above.
- 27.4 Any mediation to GTE's AIN database will be performed on a competitively neutral, nondiscriminatory basis. Any network management controls found necessary to protect the SCP from an overload condition must be applied on a nondiscriminatory basis for all users of that database, including GTE. GTE and AT&T agree that any load mediation will affect all links to the STP, including GTE's, in a like manner. AT&T will provide the information necessary to ensure that GTE is able to engineer sufficient capacity on the AIN SCP platform.

28. **Routing to Directory Assistance and Operator Services**

- 28.1 Where AT&T purchases Local Switching as an Unbundled Element, upon AT&T's request, GTE will, where technically feasible, provide the functionality and features required to modify the AT&T Customer's line at GTE's local switch (LS) to route all calls to the AT&T Network for local Directory Assistance and the AT&T Platform for Operator Services. AT&T shall pay GTE's costs, if any, pursuant to the pricing standards of Section 252(d) of the Act and in such amounts or levels as determined by the Commission for implementation of such routing. Neither this Section 28.1 nor any other section contained in this Agreement shall obligate GTE to route, or provide the functionality and features required to modify the AT&T Customer's line at GTE's local switch (LS) to route calls to the AT&T Network for local Directory Assistance and the AT&T Platform for Operator Services when AT&T purchases Local Services. Local Directory Assistance and Operator Services calls dialed by AT&T Customers when AT&T purchases Local Services shall be routed to GTE's Directory Assistance and Operator Services platforms.

28.2 **Directory Assistance**

Upon AT&T's request, where technically feasible, and where AT&T purchases Local Switching as an Unbundled Element, GTE shall route local Directory Assistance calls, including 411 and (NPA) 555-1212, dialed by AT&T Customers directly to the AT&T platform. AT&T shall pay GTE's costs, if any, pursuant to the pricing standards of Section 252(d) of the Act and in such amounts or levels as determined by the Commission for implementation of such routing. Nothing in this Section 28.2 shall obligate GTE to route Local Directory Assistance calls to the AT&T Network when AT&T purchases Local Services.

28.3 **Operator Services**

Upon AT&T's request, where technically feasible, and where AT&T purchases Local Switching as an Unbundled Element, GTE shall route local Operator Services calls (0+, 0-) dialed by AT&T Customers directly to the AT&T Local Operator Services platform. Such traffic shall be routed over trunk groups specified by AT&T which connect GTE end offices and the AT&T Local Operator Services platform, using standard Operator Services dialing protocols of 0+ or 0-. Where intraLATA presubscription is not available, GTE will provide the functionality and features within its local switch (LS), to route AT&T Customer dialed 0- and 0+ intraLATA calls to the AT&T designated line or trunk on the Main Distributing Frame (MDF) or Digital Cross Connect (DSX) panel via Modified Operator Services (MOS) Feature Group C signaling. Where intraLATA presubscription is available, AT&T Customer dialed 0- and 0+ intraLATA calls will be routed to the intraLATA PIC carrier's designated operator services platform. In all cases, GTE will provide post-dial delay no greater than that provided by GTE for its end user customers. For switches lacking the existing capacity and capability to provide the customized rerouting described in this Section 28, GTE shall develop alternative forms of customized routing. AT&T shall pay GTE's costs, if any, pursuant to the pricing standards of Section 252(d) of the Act and in such amounts or levels as determined by the Commission for implementation of such routing. Nothing in this Section 28.3 shall obligate GTE to route Local Operator Service calls to the AT&T Network when AT&T purchases Local Services.

28.4 **Repair Calls**

In the event an AT&T Customer calls GTE with a request for repairs, GTE shall provide the AT&T Customer with AT&T's repair 800-telephone number. AT&T agrees to provide GTE with AT&T's repair 800-telephone numbers.

In the event a GTE Customer calls AT&T with a request for repairs, AT&T shall provide the GTE Customer with GTE's repair 800-telephone number. GTE agrees to provide AT&T with GTE's repair 800-telephone number.

28.5 Non-discriminatory Treatment

All direct routing capabilities described herein shall permit AT&T Customers to dial the same telephone numbers for AT&T Directory Assistance, Local Operator and the same number of digits for Repair Services that similarly-situated GTE Customers dial for reaching equivalent GTE services. AT&T and GTE will use 800/888 numbers where necessary to achieve this result.

28.6 Emergency Calls

Within thirty (30) days of AT&T's request, GTE shall in accordance with Applicable Law, use commercially reasonable efforts to assist AT&T in obtaining the emergency public agency (e.g., police, fire, ambulance) telephone numbers linked to each NPA-NXX. Such data will be transmitted in a mutually agreeable format. GTE shall not be liable for any inaccuracies contained in such data. GTE will, in a timely manner, transmit to AT&T upon AT&T's request, changes, alterations, modifications and updates to such data.

28.7 [Intentionally Deleted.]

28.7.1 [Intentionally Deleted.]

28.7.2 [Intentionally Deleted.]

28.8 Line Information Database Updates

GTE shall update and maintain AT&T Customer information in the GTE Line Information Database ("LIDB") in the same manner and on the same schedule that it maintains information in LIDB for GTE Customers.

28.9 Telephone Line Number Calling Cards

Upon request by an AT&T Customer or by AT&T on behalf of an AT&T Customer, and effective as of the date of an end user's subscription to AT&T service (or such later date as such request is received), GTE will remove any GTE-assigned telephone line calling card number (including area code) ("TLN") from GTE's LIDB. AT&T may issue a new telephone calling card to such customer, utilizing the same TLN, and AT&T shall have the right to enter such TLN in AT&T's LIDB for calling card validation purposes.

28.10 End Office Features

GTE shall provide the following end-office features in those end offices in which such features are available to GTE Customers: CLASS features; Repeat Dial Capability; Multi-line Hunting; and trunk connectivity to private branch exchange switches (PBX's) and Direct Inward Dialed Services and all other end-office features that GTE makes available to GTE Customers.

28.11 Call Blocking

Upon AT&T's request and when available to similarly-situated GTE Customers, GTE will provide blocking on a line by line basis of an AT&T Customer's access to any or all of the following call types: 900/976; bill to third and collect; and such other call types for which GTE provides blocking to similarly situated GTE Customers.

28.12 Law Enforcement and Service Annoyance

Not later than forty-five (45) business days after the Effective Date, GTE and AT&T will begin the process of developing procedures to handle requests from law enforcement agencies for service termination, wire taps and provisions of Customer Usage Data pursuant to a lawful process as well as procedures to handle AT&T Customer complaints concerning harassing or annoying calls. Such procedures will include, but not be limited to, a process for AT&T to interface with GTE regarding law enforcement and service annoyance issues on a 24 hour per day, 7 days a week basis and otherwise on the same basis as GTE provides access for its own customers.

29. Service Support Functions

29.1 Electronic Interface

29.1.1 [Intentionally Deleted.]

29.1.1.1 [Intentionally Deleted.]

29.1.2 [Intentionally Deleted.]

29.1.3 GTE will make available all services and functions covered under this Agreement via the then Currently Available national interface options provided to AT&T by GTE for purposes of connecting to GTE's Operations Support Systems ("OSS"). GTE and AT&T will mutually agree upon the date for implementation of the interface options in the State.

29.1.4 [Intentionally Deleted.]

29.1.5 [Intentionally Deleted.]

29.1.6 GTE shall provide the same information, of the same quality and within the same time frames for Pre-Ordering, Ordering/Provisioning, Maintenance/Repairs and Billing to AT&T as GTE provides to itself. The Parties recognize that GTE is not required to establish new systems or processes in order to provide information to AT&T which GTE does not provide to itself.

29.1.7 GTE shall recover its costs of creating the permanent OSS gateway and any interim interfaces in accordance with Section 42 of this Agreement.

29.2 **Service Standards**

29.2.1 GTE shall ensure that all Service Support Functions used to provision Local Service to AT&T for resale are provided at a quality level equal to that which GTE provides to itself, to its end users or to its affiliates.

29.2.2 Not later than twenty (20) business days after the Effective Date of this Agreement, GTE and AT&T shall begin the process of developing mutually agreed-upon escalation and expedite procedures to be employed at any point in the Local Service Pre-Ordering, Ordering/Provisioning, Testing, Maintenance, Billing and Customer Usage Data transfer processes to facilitate rapid and timely resolution of Disputes.

29.3 **Point of Contact for the AT&T Customer**

29.3.1 Except as otherwise provided in this Agreement or as directed by AT&T, AT&T shall be the single and sole point of contact for all AT&T Customers with respect to AT&T Local Services.

29.3.2 GTE shall refer all questions regarding any AT&T service or product directly to AT&T at a telephone number specified by AT&T and provided to GTE for that purpose.

29.3.3 GTE representatives who receive inquiries regarding AT&T services: (i) shall refer callers who inquire about AT&T services or products to the numbers provided; and (ii) will not in any way disparage or discriminate against AT&T, or its products or services.

29.4 **Single Point of Contact**

Each Party shall provide the other Party with a single point of contact ("SPOC") for each functional area for all inquiries regarding the implementation of this Part. Each Party shall accept all inquiries from the other Party and provide timely responses.

29.5 **Service Order**

To facilitate the ordering of new service for resale or changes to such service to an AT&T Customer, AT&T's representative will have access to GTE

Customer information to enable the AT&T representative to perform the tasks enumerated below. Until electronic interfaces are established, these functions will be performed with the use of an 800 number.

- 29.5.1 Obtain customer account information through the same nondiscriminatory access to Operation Support Systems for pre-ordering, ordering, provisioning, maintenance and repair, and billing as GTE provides itself including information regarding the facilities and services assigned to individual customers.
- 29.5.2 Obtain information on all features and services available, including new services, by LSO identified by switch, NPA-NXX and customer street address.
- 29.5.3 Submit the AT&T Customer order by submitting an LSR using the agreed upon electronic interface (the Network Data Mover or NDM) for all desired features and services;
- 29.5.4 Assign a telephone number, including a vanity number, (if the AT&T Customer does not have one assigned). As an interim step prior to the implementation of the electronic interface specified in Section 29.1, GTE will establish an 800 (toll-free) number for AT&T;
- 29.5.5 Submit the appropriate directory listing using the agreed to EI;
- 29.5.6 Determine if a service call is needed to install the line or service;
- 29.5.7 Schedule dispatch and installation, if applicable;
- 29.5.8 Provide service availability dates to customer;
- 29.5.9 Order local and intraLATA toll service and enter AT&T Customer's choice of primary interexchange carrier on a single, unified order; and
- 29.5.10 Suspend, terminate or restore service to an AT&T Customer using agreed to methods (temporary disconnects for nonpayment may not be requested using the LSR).

29.6 **Provisioning**

- 29.6.1 After receipt and acceptance of an LSR, GTE shall provision such LSR in accordance with the following Intervals and in accordance with the service parity standards and other performance standards specified in Section 11 and Attachment 12.
- 29.6.2 GTE shall provide AT&T with service status notices, on a Real Time basis. Such status notices shall include the following:

- 29.6.2.1 Firm order confirmation, including service availability date and information regarding the need for a service dispatch for installation;
- 29.6.2.2 Notice of service installation issued at time of installation, including any additional information, such as material charges;
- 29.6.2.3 Changes/rejections/errors in LSRs;
- 29.6.2.4 Service completion;
- 29.6.2.5 Jeopardies and missed appointments;
- 29.6.2.6 Charges associated with necessary construction;
- 29.6.2.7 Order status at critical intervals;
- 29.6.2.8 Test results of the same type that GTE records for itself or its own customers.
- 29.6.3 GTE shall inform AT&T of overall change order flexibility and any changes thereto on a Real Time basis.
- 29.6.4 GTE shall notify AT&T prior to making any changes in the services, features or functions specified on the LSR. If an AT&T Customer requests a service change at the time of installation GTE shall refer the AT&T Customer to AT&T.
- 29.6.5 GTE shall provide provisioning support to AT&T on the same basis that it provides to other competitive LECs and to itself. GTE retains full discretion to control the scheduling of its provisioning workforce.
- 29.6.6 GTE shall provide training for all GTE employees who may communicate, either by telephone or face-to-face, with AT&T Customers, during the provisioning process. Such training shall include training on compliance with the branding requirements of this Agreement.

29.7 **Provision of Customer Usage Data**

GTE shall provide the Customer Usage Data recorded by GTE. Such data shall include complete AT&T Customer usage data for Local Service, (i.e., the same usage data that GTE records for billing its own customers), in accordance with the terms and conditions set forth in Attachment 7.

29.8 **Service/Operation Readiness Testing**

- 29.8.1 In addition to testing described elsewhere in this Section 29, GTE shall test the systems used to perform the following functions at a negotiated interval and in no event less than ten (10) business days prior to commencement of

GTE's provision of Local Service to AT&T, in order to establish system readiness capabilities:

- 29.8.1.1 All interfaces between AT&T and GTE work centers for Service Order Provisioning;
- 29.8.1.2 Maintenance, Billing and Customer Usage Data;
- 29.8.1.3 The process for GTE to provide customer profiles;
- 29.8.1.4 The installation scheduling process;
- 29.8.1.5 Network alarm reporting;
- 29.8.1.6 Telephone number assignment;
- 29.8.1.7 Procedures for communications and coordination between AT&T SPOC and GTE SPOC;
- 29.8.1.8 Procedures for transmission of Customer Usage Data; and
- 29.8.1.9 Procedures for transmitting bills to AT&T for Local Service.
- 29.8.2 The functionalities identified above shall be tested in order to determine whether GTE performance meets the service parity requirements and other performance standards specified in Section 11. GTE shall make available sufficient technical staff to perform such testing. GTE technical staff shall be available to meet with AT&T as necessary to facilitate testing. GTE and AT&T shall mutually agree on the schedule for such testing.
- 29.8.3 At AT&T's request, GTE shall provide to AT&T any results of the testing performed pursuant to the terms of this Part. AT&T may review such results and may notify GTE of any failures to meet the requirements of this Agreement.
- 29.8.4 GTE shall provide to AT&T the same type and quality of loop testing information that it provides to and records for itself. Where GTE develops loop testing information as a matter of course, it will make that information available to AT&T where such information is relevant to AT&T's business. Where GTE maintains the internal discretion to test loops as needed, GTE will provide similar testing discretion to AT&T. AT&T shall pay the full cost of any such discretionary testing.
- 29.8.5 Within 60 days of the Effective Date of this Agreement, AT&T and GTE will agree upon a process to resolve cooperative testing issues and technical issues relating to GTE's provision of Local Services to AT&T. The agreed upon process shall include procedures for escalating disputes and unresolved

issues up through higher levels of each company's management. If AT&T and GTE do not reach agreement on such a process within 60 days, any issues that have not been resolved by the Parties with respect to such process shall be submitted to the ADR procedures set forth in Section 15 and Attachment 1 of this Agreement unless both Parties agree to extend the time to reach agreement on such issues.

29.9 Maintenance

GTE shall provide maintenance in accordance with the requirements and standards set forth in Attachment 5 and in accordance with the service parity requirements set forth in this Agreement.

29.10 Billing For Local Service

29.10.1 GTE shall bill AT&T for Local Service provided by GTE to AT&T pursuant to the terms of this Part, and in accordance with the terms and conditions for Connectivity Billing and Recording in Attachment 6.

29.10.2 GTE shall recognize AT&T as the customer of record for all Local Service and will send all notices, bills and other pertinent information directly to AT&T.

30. Pay Phone Lines and Pay Phone Services

30.1 Intentionally left blank.

30.2 "Pay phone lines" are defined as the loop from the pay phone point of demarcation to the Service Wiring Center and includes all supporting central office functions and features.

30.3 GTE shall make available to AT&T for resale the following classes of pay phone lines:

30.3.1 Customer Owned Coin Operated Telephone (COCOT) Lines;

30.3.2 Coinless COCOT Lines;

30.3.3 Coin Lines in those jurisdictions where provision of such lines is required by law;

30.3.4 [This section left intentionally blank]

30.3.5 [Intentionally Deleted.]

30.4 [Intentionally Deleted.]

30.5 GTE shall make available pay phone line service options as follows:

- 30.6 When providing COCOT Lines to AT&T for resale, GTE shall offer the following, to the extent that GTE provides such services and in those jurisdictions and/or central offices where available: originating line screening; billed number screening; PIC protection for all 1+ inter and intraLATA traffic (when presubscription is authorized); one way and/or two way service (if so provided in the applicable tariff) on the line; detailed billing showing all 1+ traffic; AT&T's service center phone number to all AT&T end users that contact GTE service centers; number portability for end users; touchtone service; line side answer supervision; GTE designated contact center as single point of contact for customer service; provisioning of 911 service; access to Answer Number Identifier (ANI) Information; all information necessary to permit AT&T to bill end users for access line usage; the same monitoring and diagnostic routines as GTE utilizes on its own facilities; one directory for each line installed; blocking for 1+ international calls, 10XXX1+ international calls 1-900 calls, 1-976 calls DA link, any 1+ service that can be billed to the line but that is not rated, 1-700 calls, 1-500 calls, and in bound international calls where SS7 signaling is available.
- 30.7 When providing Coinless COCOT Lines to AT&T for resale, GTE shall offer the following, to the extent that GTE provides such services and in those jurisdictions and/or central offices where available: originating line screening; billed number screening; PIC protection for all 1+ inter and intraLATA traffic (where inter and intraLATA presubscription is available); one way and/or two way service on the line (if so provided in the tariff); flat service where flat service is required by the applicable tariff, measured service where measured service is required by the applicable tariff, and both flat and measured service where both flat and measured service are required by the applicable tariff; detailed billing showing all 1+ traffic; AT&T's service center phone number to all AT&T end users that contact GTE service center; number portability for end users; touchtone service; GTE designated contact center as single point of contact for customer service; provisioning of 911 service; access to ANI information; all information necessary to permit AT&T to bill end users for access line usage; the same monitoring and diagnostic routines as GTE utilizes on its own facilities; one directory for each line installed; blocking for any service that can be billed to the line but not rated and all 1+ calls except where local mandate requires access to Directory Assistance.
- 30.8 [Intentionally Deleted.]
- 30.9 When providing Customer Owned Pay Telephone (COPT) Lines to AT&T for resale, GTE shall offer the following to the extent that GTE provides such services and in those jurisdictions and/or central offices where available. Access to all Central Office intelligence required to provide COPT Line pay phone services; far end disconnect recognition; call timing for intra- and InterLATA calls; at the customer's option, one way or two way service on the

line in those jurisdictions where available; detailed billing showing all 1+ traffic; AT&T's service center phone number to all AT&T end users; touchtone service; line side supervision in those jurisdictions where available; GTE designated contact center for use by AT&T only as single point of contact for customer service; provisioning of 911 service; access to ANI information; all information necessary to permit AT&T to bill end users for access line usage; the same monitoring and diagnostic routines as GTE utilizes on its own facilities; one directory for each line installed; blocking for 1+ international calls and any 1+ service that cannot be rated by the phone pay line or any operator service.

- 30.10 For any pay phone line provided to AT&T for resale, GTE shall also make available to AT&T any future pay phone line option that GTE provides to any of its own customers using such a pay phone line.
- 30.11 GTE shall adhere to the following additional requirements when providing pay phone lines for resale:
 - 30.11.1 GTE shall provide AT&T with the same call restrictions and fraud protections used by GTE in connection with its pay phones;
 - 30.11.2 GTE shall not block AT&T's existing access to NAI codes;
 - 30.11.3 GTE shall forward all AT&T pay phone customers to the designated AT&T line or trunk group for handling Operator Services or Directory Assistance calls.
 - 30.11.4 [Intentionally Deleted.]
 - 30.11.5 GTE shall provide all pay phone lines for resale to AT&T at the wholesale discount price required by the Commission, except that GTE is not required to provide a wholesale discount on pay phone services that it does not offer at retail.

PART II: UNBUNDLED NETWORK ELEMENTS

31. **Introduction**

This Part II sets forth the unbundled Network Elements that GTE agrees to offer to AT&T in accordance with its obligations under Section 251(c)(3) of the Act and effective rules of the FCC. The specific terms and conditions that apply to the unbundled Network Elements are described below and in Attachment 2. Prices for Network Elements are set forth in Part V and Attachment 14 of this Agreement.

32. **Unbundled Network Elements**

32.1 GTE will offer Network Elements to AT&T on an unbundled basis at rates set forth in Attachment 14.

32.2 GTE will permit AT&T to interconnect AT&T's facilities or facilities provided by AT&T or by third parties with each of GTE's unbundled Network Elements at any point designated by AT&T that is technically feasible.

32.3 AT&T, at its option, may designate any Currently Available network interface.

32.4 Pursuant to the terms of this Agreement, AT&T may use one or more Network Elements to provide any Telecommunications Service that such Network Element is capable of providing.

32.5 Network Elements offered to AT&T by GTE pursuant to this Agreement shall be offered individually and for purposes of AT&T offering telecommunications services to its end-user customers. In no event shall GTE be required to bundle or combine Network Elements offered pursuant to this Agreement **GTE shall offer each Network Element individually and in combination with any other Network Element or Network Elements, so long as such combination is technically feasible, in order to permit AT&T to combine such Network Element or Network Elements with another Network Element or other Network Elements obtained from GTE or with network components provided by itself or by third parties to provide telecommunications services to its customers.** Any bundling or combining of Network Elements purchased from GTE will be the sole responsibility of AT&T, and any such bundling or combining of Network Elements shall be performed at AT&T's sole expense. If AT&T combines any Network Elements provided pursuant to this Agreement and replicates a resold service offered by GTE, AT&T shall pay the wholesale price for such retail

service as set forth in this Agreement, not the unbundled Network Element rate. In connection with any request by AT&T that GTE provide pursuant to this Agreement, any unbundled Network Element that is located in, or terminates to, a GTE Wire Center including but not limited to GTE's central offices, serving wire centers, tandem switches, and at controlled environmental vaults, huts and cabinets; and prior to provision by GTE of any such unbundled Network Element pursuant to this Agreement, AT&T shall enter into a collocation arrangement with GTE consistent with the requirements of Attachment 3 to this Agreement and shall pay the appropriate rate for such collocation in accordance with Attachment 14 to this Agreement. If AT&T interconnects any such Network Element with GTE's Wire Centers or otherwise interconnects such Network Element with GTE's network, AT&T shall do so in accordance with Part IV of this Agreement.

[Combinations]

- 32.6 For each Network Element, GTE shall provide a demarcation point (e.g., an interconnection point at a Digital Signal Cross-Connect or Light Guide Cross-Connect panels or a Main Distribution Frame) and, if necessary, access to such demarcation point, which AT&T agrees is suitable. However, where GTE provides contiguous Network Elements to AT&T, GTE may, at its option, provide the existing interconnections and no demarcation point shall exist between such contiguous Network Elements.

[Combinations]

- 32.7 **GTE shall not charge AT&T an interconnection fee or demand other consideration for directly interconnecting any Network Element or Combination to any other Network Element or Combination provided by GTE to AT&T if GTE directly interconnects the same two Network Elements or Combinations in providing any service to its own customers or a GTE affiliate, including the use of intermediate devices, such as a digital signal cross connect panel, to perform such interconnection.**

[Combinations]

- 32.8 **The total charge to AT&T to interconnect any Network Element or Combination to any other Network Element or Combination provided by GTE to AT&T if GTE does not directly interconnect the same two Network Elements or Combinations in providing**

any service to its own customers or a GTE affiliate (e.g., the interconnection required to connect the Loop Feeder to GTE's collocated equipment), shall be the total service long-run incremental cost of providing the interconnection.

[Combinations]

32.9 Except with respect to the Loop Distribution, Loop Concentrator/Multiplexer, and Loop Feeder elements, which shall in all cases be subject to the bona fide request process described in Attachment 12, set forth below is a list of Network Elements that AT&T and GTE have identified as of the Effective Date of this Agreement and will be offered to AT&T by GTE in accordance with Applicable Law. AT&T and GTE agree that AT&T may identify additional or revised Network Elements that it desires, provided, however, that in no event shall there be a presumption that GTE is required to provide any such additional or revised Network Element(s) on the basis that the unbundling of such Network Element(s) is, will, or has become technically feasible. To the extent any such new or revised Network Elements are proprietary Network Elements, GTE's obligation, if any, to provide such new or revised Network Elements shall be determined pursuant to and in accordance with 47 CFR 51.317(b) as such rule is then in effect. All such additional or modified Network Elements shall be subject to the Bona Fide Requests Procedures outlined in Attachment 12. Descriptions and references for each Network Element identified below are set forth in Attachment 2. The Network Elements described in Attachment 2 consist of:

Loop or Loop Combination

Network Interface Device (NID)
Loop Distribution, otherwise known as Distribution Media
Loop Concentrator/Multiplexer
Loop Feeder
Local Switching
Operator Service
Directory Assistance Service
Common Transport
Dedicated Transport
Signaling Link Transport
Signaling Transfer Points
Service Control Points (SCPs)/Databases

Tandem Switching

Unused Transmission Media

OSS

Operational Support Systems will be provided in accordance with the terms of this Agreement, including without limitation, Section 29 and Attachments 2, 4, 5, 6, and 7.

[Combinations, Unused Transmission Media]

32.10 Standards for Network Elements

32.10.1 Nothing in this Agreement shall be interpreted to require GTE to bundle or combine Network Elements upon AT&T's request. Notwithstanding any other provision of this Agreement, GTE shall only be responsible for the functioning of each of the Network Elements that GTE provides to AT&T pursuant to this Agreement and under no event or circumstance shall GTE be responsible for the combined or end-to-end performance of any Network Element(s) that AT&T bundles or combines with any other Network Element(s).

[Combinations]

32.10.2 This Agreement shall only require GTE to provide unbundled access to network elements to which GTE is required to provide access under Applicable Law (including Commission orders). For example, this Agreement shall not require GTE to provide access to network elements that do not exist as part of GTE's network at the time of a requested order. GTE shall ensure that the quality of the Network Elements provided to AT&T shall be equal to network elements as such network elements would be provided by GTE to itself, its subsidiaries, its Affiliates or any other party to whom GTE provides Network Elements. Equal in quality includes, but is not limited to, parity in the design, provisioning, maintenance, and repair of Network Elements provided to AT&T. GTE shall not be required to provide AT&T with superior quality access to Network Elements.

32.10.3 [Intentionally Deleted]

32.10.3.1 If AT&T contends that GTE has failed to meet the requirements of this Section 32, AT&T will provide GTE documentation of such purported failure. Within a reasonable time period after receiving such documentation, GTE shall provide to AT&T engineering, design, performance and other network data that the parties

mutually agree in accordance with Section 23.19 of this Agreement is necessary and sufficient for AT&T to determine that the requirements of this Section 32 are being met. In the event that such data establishes that the requirements of this Section 32 are not being met, GTE shall, within ten (10) business days, cure any design, performance or other deficiency and provide new data that the parties mutually agree is sufficient for AT&T to determine that such deficiencies have been cured. To the extent that GTE is unable to meet the above time frame, GTE shall promptly notify AT&T prior to the expiration of such time frame and the Parties shall agree on a revised completion date.

32.10.3.2 The Parties agree to work cooperatively with each other to effectuate the terms and conditions of this Agreement.

32.10.4 [Intentionally Deleted]

PART III: ANCILLARY FUNCTIONS

33. **Introduction**

This Part III sets forth the Ancillary Functions that GTE agrees to offer to AT&T so that AT&T may interconnect to GTE's network and obtain access to unbundled Network Elements to use to provide services to its customers.

34. **GTE Provision of Ancillary Functions**

34.1 GTE will offer Ancillary Functions to AT&T pursuant to this Agreement on the rates, terms and conditions set forth in this Agreement.

34.2 GTE will permit AT&T to interconnect AT&T's equipment and facilities or equipment and facilities provided by AT&T or by third parties for purposes of interconnection or access to Network Elements in accordance with the interconnection provisions of this Agreement.

34.3 Pursuant to the terms of this Agreement, AT&T may use any Ancillary Function to provide any Telecommunications Service that such Ancillary Function is capable of providing.

34.4 Set forth below is the list of Ancillary Functions that AT&T and GTE have identified as of the Effective Date of this Agreement. Either Party may identify additional or revised Ancillary Functions that it desires. All such additional or revised Ancillary Functions shall be subject to the Bona Fide Requests procedures outlined in Attachment 12. Descriptions and requirements for each Ancillary Function are set forth in Attachment 3. The Ancillary Functions described in Attachment 3 consist of:

Collocation
Right of Way (ROW)
Conduit
Pole attachment

35. **Standards for Ancillary Functions**

35.1 Subject to Section 23.19, each Ancillary Function shall meet or exceed the requirements set forth in applicable technical references, as well as the performance and other requirements, identified in this Agreement.

- 35.2 Unless otherwise provided for in this Agreement or mutually agreed to by the Parties, the performance standards of such Ancillary Functions made available to AT&T under this Agreement shall be equal to that which GTE provides to itself, its subsidiaries or its Affiliates.
- 35.3 If AT&T contends that GTE has failed to meet the requirements of Part III and Attachment 3, AT&T will provide GTE documentation of such purported failure. Within a reasonable time period after receiving such documentation, GTE shall provide to AT&T engineering, design, performance and other network data that the parties mutually agree is necessary and sufficient for AT&T to determine that the requirements of Part III and Attachment 3 of this Agreement are being met. In the event that such data establishes that the requirements of Part III and Attachment 3 of this Agreement are not being met, GTE shall, within 30 business days, cure any design, performance or other deficiency and provide new data that the parties mutually agree is sufficient for AT&T to determine that such deficiencies have been cured. To the extent that GTE is unable to meet the above timeframe, GTE shall promptly notify AT&T prior to the expiration of such timeframe and the Parties shall agree on a revised completion date.
- 35.4 Unless otherwise provided in this Agreement or mutually agreed by the Parties, each Ancillary Function shall be made available to AT&T by GTE on a basis that is equal to the priorities that GTE provides to itself, its subsidiaries or its Affiliates.
- 35.5 [Intentionally deleted]

PART IV: INTERCONNECTION PURSUANT TO SECTION 251(C)(2)

36. **Scope**

Section 37 describes the physical architecture for Interconnection of the Parties' facilities and equipment for the transmission and routing of Local Traffic and Exchange Access traffic between the respective business and residential customers of the Parties pursuant to the Act. Interconnection may not be used solely for the purpose of originating a Party's own interexchange traffic. Sections 38 to 39 prescribe the specific logical trunk groups (and traffic routing parameters) which will be configured over the physical Interconnections described in this Part related to the transmission and routing of Local Traffic and Exchange Access traffic, respectively. Other trunk groups, as described in this Agreement, may be configured using this architecture.

37. **Interconnection Points and Methods.**

37.1 In each LATA identified pursuant to the procedures of Section 37.6, AT&T and GTE shall Interconnect their networks at the GTE and AT&T Wire Centers identified in such notice for the transmission and routing within that LATA of Local Traffic and Exchange Access traffic.

37.2 Interconnection in each LATA shall be accomplished at any technically feasible point within GTE's networks for a given LATA, including through collocation in GTE's Wire Centers as provided in Attachment 3. AT&T shall designate a minimum of one interconnection point within a LATA. If AT&T desires a single interconnection point within a LATA, AT&T shall ensure that GTE maintains the ability to bill for the services provided. AT&T may interconnect at one tandem in the LATA for exchange of local, mandatory EAS and IntraLATA toll traffic by bringing separate trunk groups to that interconnection point for each tandem in that LATA and then by using dedicated special access transport to extend the trunk group from the interconnection point to the designated tandem.

37.3 **Interconnection using Collocation:**

If the Parties Interconnect their networks using Collocation in GTE's Wire Centers, the following requirements apply:

37.3.1 AT&T will deploy a local service network that places switching and transmission equipment throughout the LATA. The placement of this equipment uses a combination of AT&T owned Wire Centers and collocated space in GTE Wire Centers.

37.3.2 AT&T will request interconnection with GTE at specific points in GTE's network. The following options are available for (i) the termination of traffic to the GTE network, (ii) the termination of traffic to the AT&T network and (iii) the transiting of traffic to/from a third party network.

37.4 Local Traffic and IntraLATA Toll Traffic - Originating on AT&T, Terminating on GTE.

AT&T may build trunk groups to GTE using the following representative, but not exclusive, options: (i) from AT&T collocated equipment in a Wire Center to the GTE Tandem; (ii) from AT&T collocated equipment in a GTE Wire Center to the GTE End Office Switch; or (iii) from AT&T 4ESS Switches located at AT&T POPs to the nearest GTE Tandem.

Interfaces for these interconnections may be based upon, but not limited to, the following: (i) DS1: from an AT&T-collocated DDM-2000 to a GTE Central Office Switch; (ii) SONET STS1: from an AT&T-collocated DDM-2000 to an GTE 5ESS[®]-2000 Central Office Switch and (iii) DS1/DS3: from an AT&T 4ESS Switch at an AT&T POP to a GTE Tandem using new trunk groups on existing facilities.

37.4.1 Upon request by either Party, the other Party shall provide, for the purpose of network planning and management, performance data regarding traffic characteristics with respect to the first Party's trunks and interconnections to and with the other Party. The specific quantity, timing and detail of such performance data shall be mutually agreed upon by the teams implementing this Agreement.

37.5 Transit Service Traffic

37.5.1 GTE agrees that it shall provide Transit Service to AT&T on terms and conditions set forth in this Agreement.

37.5.2 "Transit Service" means the delivery of certain traffic between AT&T and a third party LEC or ILEC by GTE over the Local/IntraLATA Trunks. The following types of traffic will be delivered: (i) Local Traffic and IntraLATA Toll Traffic originated from AT&T to such third party LEC or ILEC and (ii) Local Traffic and IntraLATA Toll Traffic originated from such third party LEC or ILEC and terminated to

AT&T where GTE carries such traffic pursuant to the Commission's primary toll carrier plan or other similar plan.

- 37.5.3 While the Parties agree that it is the responsibility of each third party LEC or ILEC to enter into arrangements to deliver Local Traffic between them, they acknowledge that such arrangements are not currently in place and an interim arrangement is necessary to ensure traffic completion. Accordingly, until the earlier of (i) the date on which either Party has entered into an arrangement with such third party LEC or ILEC to deliver Local Traffic via direct trunks or (ii) the termination of this Agreement, GTE will transit such traffic.
- 37.5.4 All networks involved in transit traffic will deliver each call to each involved network with CCIS to the extent available from third party LECs and the appropriate Transaction Capabilities Application Part (TCAP) messages to facilitate full interoperability and billing functions. In all cases, each Party is responsible to follow Exchange Message Record ("EMR") standard and exchange records with both the other Party and the terminating LEC or ILEC to facilitate the billing process to the originating network.
- 37.5.5 Transiting traffic will be delivered using the physical connection options as described in Section 37.4.

37.6 **Selection of LATAs**

- 37.6.1 If AT&T determines to offer Telephone Exchange Services in any LATA, AT&T shall provide written notice to GTE of its need to establish Interconnection in such LATA pursuant to this Agreement. This notice shall include (i) the Wire Centers that AT&T has designated in the LATA, and (ii) a non-binding forecast of AT&T's trunking requirements indicating the proposed Interconnection Activation Date. AT&T shall issue an ASR to GTE in accordance with Section 37.6.3 to order the Interconnection facilities and trunks.
- 37.6.2 Unless otherwise agreed by the Parties, the Parties shall designate the Wire Center AT&T has identified as its initial Routing Point in the LATA as the ATIWC in that LATA and shall designate the GTE Tandem Office within the LATA nearest to the ATIWC (as measured in airline miles utilizing the V&H coordinates method) as the AIWC in that LATA.
- 37.6.3 Unless otherwise agreed by the Parties, the Interconnection Activation Date in each LATA in which no construction is required shall be twenty-five (25) business days after the date on which AT&T delivered notice via an ASR to GTE pursuant to this Section. Where

construction is required, the Interconnection Activation Date shall be as mutually agreed by the Parties.

- 37.6.4 GTE and AT&T will conduct joint planning sessions to determine the following representative, but not exclusive, information: (i) forecasted number of trunk groups; and (ii) the interconnection activation date.

37.7 Additional Switches or Interconnection Points

If AT&T deploys additional switches in a LATA after the date hereof or otherwise wishes to establish Interconnection with additional GTE Wire Centers, AT&T may, upon written notice thereof to GTE, establish such Interconnection and the terms and conditions of this Agreement shall apply to such Interconnection. If GTE deploys additional switches in a LATA after the date hereof or otherwise wishes to establish Interconnection with additional AT&T Wire Centers, GTE may, upon written notice thereof to AT&T, establish such Interconnection and the terms and conditions of this Agreement shall apply to such Interconnection. If either Party establishes an additional Tandem Switch in a given LATA, the Parties shall jointly determine the requirements regarding the establishment and maintenance of separate trunk group connections and the sub-tending arrangements relating to Tandem Switches and End Offices which serve the other Party's customers within the Exchange Areas served by such Tandem Switches.

37.8 Nondiscriminatory Interconnection

Interconnection provided by GTE shall be equal in quality to that provided by GTE to itself or any subsidiary, Affiliate or other person. "Equal in quality" means the same or equivalent technical criteria and service standards that a Party uses within its own network and, at a minimum, requires GTE to design interconnection facilities to meet the same technical criteria and service standards that are used within GTE's network.

37.9 Technical Specifications

- 37.9.1 The Parties agree to establish trunk groups of sufficient capacity such that trunking is available as a direct transmission path between each AT&T and GTE interconnected Central Office. The Parties will mutually agree as to where one-way or two-way trunking will be applicable. The Parties may use two-way trunks for delivery of Local Traffic or either Party may elect to provision one-way trunks for delivery of Local Traffic to the other Party provided that where a

Party elects to provision one or more one-way trunks, the other Party shall be entitled to do the same. Each Party shall be responsible for the expenses associated with its own portion of the trunking. AT&T and GTE shall work cooperatively to install and maintain a reliable network. AT&T and GTE shall exchange appropriate information (e.g., maintenance contact numbers, network information, information required to comply with law enforcement and other security agencies of the government and such other information as the Parties shall mutually agree) to achieve this desired reliability.

37.9.2 AT&T and GTE shall work cooperatively to apply sound network management principles by invoking network management controls to alleviate or to prevent congestion.

37.10 **911/E911 Arrangements**

37.10.1 **Description of Service**

AT&T shall have the right to utilize the existing GTE 911/E911 infrastructure (as agreed in Sections 37.10.3 and 37.10.5 below) to provide all 911/E911 capabilities to its end users. AT&T will install a minimum of two dedicated trunks to GTE's 911/E911 selective routers (i.e., 911 tandem offices) that serve the areas in which AT&T provides Exchange Services, for the provision of 911/E911 services and for access to all subtending PSAPs. The dedicated trunks shall be, at minimum, DSO level trunks configured as a 2-wire analog interface or as part of a digital (1.544 Mbps) interface. Either configuration shall use CAMA type signaling with multifrequency (MF) tones that will deliver ANI with the voice portion of the call. At the request of AT&T, GTE will provide AT&T with the appropriate CLLI codes and specifications of the tandem office serving area. If an AT&T Central Office serves end users in an area served by more than one GTE 911/E911 selective router, AT&T will install a minimum of two dedicated trunks in accordance with this section to each of such 911/E911 selective routers.

37.10.2 **Transport**

If AT&T desires to obtain transport from its end office to the GTE 911 selective routers, AT&T may purchase such transport from GTE at the rates set forth in GTE's intrastate switched access tariff or in GTE's intrastate special access tariff.

37.10.3 Cooperation and Level of Performance

- 37.10.3.1 The Parties agree to provide access to 911/E911 in a manner that is transparent to the end user. The Parties will work together to facilitate the prompt, reliable and efficient interconnection of AT&T's systems to the 911/E911 platforms to ensure that 911/E911 service is fully available to AT&T's end users, with a level of performance that will provide the same grade of service as that which GTE provides to its own end users and that meets State requirements, provided, however that GTE shall not be contractually liable to AT&T in the event that the grade of service offered by GTE does not meet State requirements. To this end, GTE will provide documentation to AT&T showing the correlation of its rate centers to its E911 tandems.
- 37.10.3.2 In the event of an GTE or AT&T 911 trunk group failure, the Party that owns the trunk group will notify, on a priority basis, the other Party of such failure, which notification shall occur within two (2) hours of the occurrence or sooner if required under Applicable Law. The Parties will exchange a list containing the names and telephone numbers of the support center personnel responsible for maintaining the 911 Service between the Parties.
- 37.10.3.3 When AT&T purchases transport, GTE will provide AT&T with the order number and the circuit identification code in advance of the service due date.
- 37.10.3.4 AT&T or its third party agent will provide CNA data to GTE for use in entering the data into the 911 data base. The initial CNA data will be provided to GTE in a format prescribed by NENA (National Emergency Number Association). AT&T is responsible for providing GTE updates to the CNA data and error corrections which may occur during the entry of CNA data to the GTE 911 Database System. GTE will confirm receipt of such data and corrections by close of business on the next Business Day by providing AT&T with a report of the number of items sent, the number of items entered correctly, and the number of errors.
- 37.10.3.5 AT&T will monitor the 911 circuits for the purpose of determining originating network traffic volumes. AT&T will notify GTE if the traffic study information indicates that additional circuits are required to meet the current level of 911 call volumes.
- 37.10.3.6 [Intentionally deleted.]
- 37.10.3.7 Inter-office trunks provided for 911 shall be engineered to assure minimum P.01 transmission grade of service as measured

during the busy day/busy hour. A minimum of two trunks shall be provided by AT&T.

37.10.4 Updates to MSAG

It shall be the responsibility of AT&T to ensure that the address of each of its end users is included in the Master Street Address Guide ("MSAG") via information provided on AT&T's Local Service Request ("LSR") or via a separate feed established by AT&T and GTE pursuant to Section 37.10.5 of this Agreement. Any MSAG change that appears to be required by AT&T must be approved by the County. Within thirty (30) days after the Effective Date of this Agreement, GTE shall provide AT&T with an initial electronic copy and a paper copy of the MSAG or its equivalent. Prior to the time that updates are available electronically, GTE will provide updates to AT&T on a monthly basis. Thereafter, GTE will provide updates to AT&T as changes are made.

37.10.5 Updates to Database

GTE and AT&T will work together to develop the process by which the 911/E911 database will be updated with AT&T's end user 911/E911 information. AT&T shall have the right to verify the accuracy of the information regarding AT&T's end users in the 911/E911 database.

37.10.6 Compensation

In situations in which GTE is responsible for maintenance of the 911/E911 database and can be compensated for maintaining AT&T's information by the municipality, GTE will seek such compensation from the municipality. GTE will seek compensation from AT&T only if and to the extent that GTE is unable to obtain such compensation from the municipality.

38. Transmission and routing of telephone exchange service traffic pursuant to section 251(c)(2)

38.1 Scope of Traffic

This Section prescribes parameters for trunk groups (the "Local/IntraLATA Trunks") to be effected over the Interconnections specified in Part IV for the transmission and routing of Local Traffic and IntraLATA Toll Traffic between the Parties' respective Telephone Exchange Service Customers.

38.2 Limitations

No Party shall terminate Exchange Access traffic or originate untranslated 800/888 traffic over Local/IntraLATA Interconnection Trunks.

38.3 Trunk Group Architecture and Traffic Routing

The Parties shall jointly engineer and configure Local/IntraLATA Trunks over the physical Interconnection arrangements as follows:

38.3.1 Notwithstanding anything to the contrary contained in this Section, if the traffic volumes between any two Central Office Switches at any time exceeds the CCS busy hour equivalent of one DS1, the Parties shall within sixty (60) days after such occurrence establish new direct trunk groups to the applicable End Office(s) consistent with the grades of service and quality parameters set forth in the Grooming Plan.

38.3.2 Only those valid NXX codes served by an End Office may be accessed through a direct connection to that End Office.

38.3.3 Each Party shall ensure that each Tandem connection permits the completion of traffic to all End Offices which sub-tend that Tandem or to End Offices which sub-tend an additional Tandem, provided, that AT&T enters into an appropriate billing arrangement pursuant to Section 38.3.4. Alternatively, each Party shall establish and maintain separate trunk groups connected to each Tandem of the other Party which serves, or is sub-tended by End Offices which serve, such other Party's customers within the Exchange Areas served by such Tandem Switches.

38.3.4 GTE will provide tandem to tandem switching to AT&T. AT&T shall enter into an appropriate billing arrangement with GTE to ensure recovery of inter-tandem switching costs at rates established by the Commission.

38.4 Signaling

SS7 Signaling may be used for signaling for IntraLATA and local calls between AT&T switches, between AT&T switches and GTE switches, and between AT&T switches and those third party networks with which GTE's SS7 network is interconnected.

38.4.1 Where available, CCIS signaling shall be used by the Parties to set up calls between the Parties' local networks. Each Party shall

supply Calling Party Number (CPN) within the SS7 signaling message, if available. If Common Channel Interoffice Signaling ("CCIS") is unavailable, MF (Multi-Frequency) signaling shall be used by the Parties.

- 38.4.2 Each Party is responsible for requesting Interconnection to the other Party's CCIS network, where SS7 signaling on the trunk group(s) is desired. Each Party shall connect, either directly or via arrangements with third party providers, to a pair of access STPs where traffic will be exchanged. The Parties shall establish interconnection at the STP.
- 38.4.3 The Parties will cooperate on the exchange of Transactional Capabilities Application Part (TCAP) messages to facilitate interoperability of CCIS based features between their respective networks, including all CLASS features and functions, to the extent each Party offers such features and functions to its Customers. Each Party shall honor all privacy indicators as required under Applicable Law.
- 38.4.4 Where available and upon the request of the other Party, each Party shall cooperate to ensure that its trunk groups are configured utilizing the B8ZS ESF protocol for 64 kbps clear channel transmission to allow for ISDN interoperability between the Parties' respective networks.

38.5 Grades of Service

The Parties shall initially engineer and shall jointly monitor and enhance all trunk groups consistent with the Grooming Plan.

38.6 Measurement and Billing

- 38.6.1 Each Party shall pass Calling Party Number (CPN) information on each call that it originates and terminates over the Local/IntraLATA Trunks. Until GTE installs the capability to use actual CPN information, all calls exchanged shall be billed either as Local Traffic or IntraLATA Toll Traffic based upon a percentage of local usage (PLU) factor calculated based on the amount of actual volume (or best estimate) during the preceding three months. The PLU will be reevaluated every three (3) months.
- 38.6.2 Measurement of Telecommunications traffic billed hereunder shall be (i) in actual conversation time as specified in FCC terminating FGD Switched access tariffs for Local Traffic and (ii) in accordance

with applicable tariffs for all other types of Telecommunications traffic.

38.7 Reciprocal Compensation Arrangements

Reciprocal Compensation for the exchange of traffic shall be paid as described in Part V and Attachment 15, at the prices specified in Attachment 14.

38.8 Transiting Traffic

38.8.1 The exchange of transiting traffic is defined in Section 37.5.2.

38.8.2 Compensation for transiting traffic shall be paid as described in Part V and Attachment 15, at the prices specified in Attachment 14.

39. Transmission and Routing of Exchange Access Traffic

39.1 Scope of Traffic

This Section prescribes parameters for certain trunk groups ("Access Toll Connecting Trunks") to be established over the Interconnections specified in this Agreement for the transmission and routing of Exchange Access traffic and nontranslated 800 traffic between AT&T Telephone Exchange Service Customers and Interexchange Carriers.

39.2 Trunk Group Architecture and Traffic Routing

39.2.1 The Parties shall jointly establish Access Toll Connecting Trunks by which they will jointly provide Tandem transported Switched Exchange Access Services to Interexchange Carriers to enable such Interexchange Carriers to originate and terminate traffic from and to AT&T's customers.

39.2.2 Access Toll Connecting Trunks shall be used solely for the transmission and routing of Exchange Access and nontranslated 800/888 traffic to allow AT&T's customers to connect to or be connected to the interexchange trunks of any Interexchange Carrier which is connected to a GTE access Tandem.

39.2.3 The Access Toll Connecting Trunks shall be two way trunks connecting an End Office Switch that AT&T utilizes to provide Telephone Exchange Service and Switched Exchange Access Service in a given LATA to an access Tandem Switch GTE utilizes to provide Exchange Access in such LATA.

39.2.4 The Parties shall jointly determine which GTE access Tandem(s) will be sub-tended by each AT&T End Office Switch.

39.2.5 Only those valid NXX codes served by an End Office may be accessed through a direct connection to that End Office.

40. Transport and Termination of Information Services Traffic

40.1 Each Party shall route Information Service Traffic which originates on its own network to the appropriate information services platform(s) connected to the other Party's network over the Local/IntraLATA Trunks.

40.2 The Party ("Originating Party") on whose network the Information Services Traffic originated shall provide an electronic file transfer or monthly magnetic tape containing recorded call detail information to the Party ("Terminating Party") to whose information platform the Information Services Traffic terminated.

40.3 The Terminating Party shall provide to the Originating Party via electronic file transfer or magnetic tape all necessary information to rate the Information Services Traffic to the Originating Party's customers and establish uncollectible reserves pursuant to the Terminating Party's agreements with each information provider.

40.4 The Originating Party shall bill and collect such information provider charges and remit the amounts collected to the Terminating Party less:

40.4.1 The Information Services Billing and Collection fee set forth in Attachment 14; and

40.4.2 An uncollectibles reserve calculated based on the uncollectibles reserve in the Terminating Party's billing and collection agreement with the applicable information provider; and

40.4.3 Customer adjustments provided by the Originating Party.

40.5 The Originating Party shall provide to the Terminating Party sufficient information regarding uncollectibles and customer adjustments. The Terminating Party shall pass through the adjustments to the information provider. Final resolution regarding all disputed adjustments shall be solely between the Originating Party and the information provider.

40.6 Nothing in this Agreement shall restrict either Party from offering to its Telephone Exchange Service Customers the ability to block the completion of Information Service Traffic.

41. **Installation, Maintenance, Testing and Repair**

41.1 **Grooming Plan**

Within ninety (90) days after the Effective Date, AT&T and GTE shall jointly begin the development of a plan (the "Grooming Plan") which shall define and detail, inter alia, (i) standards to ensure that Interconnection trunk groups experience a grade of service, availability and quality in accord with all appropriate relevant industry-accepted quality, reliability and availability standards and in accordance with the levels GTE provides to itself, or any subsidiary, Affiliate or other person; (ii) the respective duties and responsibilities of the Parties with respect to the administration and maintenance of the Interconnections (including signaling) specified in Part IV and the trunk groups specified in Part IV, including standards and procedures for notification and discoveries of trunk disconnects; (iii) disaster recovery and escalation provisions; and (iv) such other matters as the Parties may agree.

41.2 **Operation and Maintenance**

Each Party shall be solely responsible for the installation, operation and maintenance of equipment and facilities provided by it for Interconnection, subject to compatibility and cooperative testing and monitoring and the specific operation and maintenance provisions for equipment and facilities used to provide Interconnection. Operation and maintenance of equipment in Virtual Collocation shall be in accordance with the provisions of Attachment 3. Each party shall also be responsible for engineering and maintaining its network on its side of the interconnection point. If and when the Parties choose to interconnect at a mid-span meet, the Parties will jointly provision the fiber optic facilities that connect the two networks and shall share the financial and other responsibilities for those facilities.

PART V: PRICING

42. **General Principles**

Prices applicable to, and costs GTE is entitled to recover for, its performance under this Agreement including but not limited to provision of services under this Agreement (e.g. provision of resold Local Services, Network Elements, Ancillary Functions, Interconnection and any new and additional services or Network Elements to be provided hereunder), shall be priced in accordance with all applicable provisions of the Act, applicable court decisions, the effective rules and orders of the FCC and any state public utility commission having jurisdiction over this Agreement, and other Applicable Law. Numerous provisions in this Agreement and its Attachments specifically refer to or raise issues with regard to the extent and nature of AT&T's obligation to reimburse GTE for costs GTE incurs in preparation for and in providing services under this Agreement. Additional provisions of this Agreement which may require GTE to perform may not specifically refer to AT&T's obligation to pay GTE for the costs GTE incurs to satisfy its obligations under this Agreement. In all such cases, and for all costs incurred by GTE in performing under this Agreement, and to the extent the Parties do not agree otherwise, AT&T's obligation, if any, to compensate GTE, and GTE's entitlement to recover such costs, shall be determined in accordance with all applicable provisions of the Act, applicable court decisions, the effective rules and orders of the FCC and any state public utility commission having jurisdiction over this Agreement, and other Applicable Law. The Parties further agree that the amount and timing of AT&T's obligation, if any, with respect to specific cost recovery issues may ultimately be determined by the Commission or another party having jurisdiction over this Agreement (the "Deciding Party"). Unless and until such time as the Deciding Party renders a final decision as to the specific amount of AT&T's obligation with respect to a specific cost recovery or pricing issue, to the extent AT&T requests or requires services which cause GTE to incur costs or for which GTE is entitled to charge a price, the Parties shall endeavor to negotiate an agreed interim cost recovery mechanism (price) for the unrecovered costs at issue in accordance with the mechanism for establishing prices to be determined (TBD prices) set forth in Section 6 of Attachment 14 to this Agreement. In such case, references to the Commission as they appear in Section 6 of Attachment 14 shall be to the Deciding Party. Nothing in this Section 42 shall foreclose either party from asserting its rights pursuant to Section 43 of this Agreement or Attachment 14 to this Agreement.

43. **Price Schedules**

43.1 **Local Service Resale**

The prices to be charged to AT&T for Local Services shall be as specified in Attachment 14.

43.2 **Unbundled Network Elements**

The prices charged to AT&T for Unbundled Network Elements shall be as specified in Attachment 14 and shall be nondiscriminatory.

- 43.2.1 If implementation of an unbundled loop feeder supports shared use of required unbundling facilities, the cost of such facilities shall be allocated and prorated among all users in a non-discriminatory and competitively neutral manner. If such implementation supports only AT&T's use, then AT&T shall pay to GTE the incremental cost of such implementation.
- 43.2.2 If implementation of an unbundled loop concentrator/multiplexer element supports shared use of required unbundling facilities, the cost of such facilities shall be allocated and prorated among all users in a non-discriminatory and competitively neutral manner. If implementation supports only AT&T's use, then AT&T shall pay to GTE the incremental cost of such implementation.
- 43.2.3 AT&T will be responsible for the costs (if any) required to create an interface at the main distribution frame if such interface does not already exist, such as in the case of an Integrated Digital Loop Carrier System.
- 43.3 **Interconnection**
 - 43.3.1 Reciprocal Compensation applies for transport and termination of Local Traffic billable by GTE or AT&T which a Telephone Exchange Service Customer originates on GTE's or AT&T's network for termination on the other Party's network. Reciprocal Compensation for exchange of traffic shall be paid on a Bill and Keep basis.
 - 43.3.2 The Reciprocal Compensation arrangements set forth in this Agreement are not applicable to Switched Exchange Access Service. All Switched Exchange Access Service and all IntraLATA Toll Traffic shall continue to be governed by the terms and conditions of the applicable federal and state tariffs.
 - 43.3.3 Each Party shall charge the other Party its effective tariffed intraLATA FGD switched access rates for the transport and termination of all IntraLATA Toll Traffic.
 - 43.3.4 Standard meet point billing arrangements, as defined in Attachment 6, shall apply when the completion of a toll call involves both GTE and AT&T facilities, as further described in Attachment 6.
 - 43.3.5 Access Charges. To compensate AT&T for the applicable access revenues associated with terminating interLATA or intraLATA toll calls to AT&T subscribers whose telephone numbers have been

ported from GTE and routed by GTE, GTE shall pay AT&T eighty-five percent (85%) of the terminating access revenues as determined on a state basis by the following formulae. GTE will be responsible for providing the data and performing the calculations of the formulae. AT&T will have the right to audit both the data and calculations upon request. Such formulae shall be updated on a quarterly basis at the request of either Party. The format and date for settlement of access charges shall be mutually agreed between the Parties.

43.3.5.1 (total terminating access revenues generated from ported numbers and routed by GTE for business customers) divided by the (number of business subscriber lines) times (the number of business lines ported to AT&T) and

43.3.5.2 (total terminating access revenues generated from ported numbers and routed by GTE for residential customers) divided by (the number of residential subscriber lines) times (the number of residential lines ported to AT&T).

43.3.6 **Transiting Traffic**

The following applies to all scenarios with transiting traffic.

43.3.6.1 AT&T shall pay to GTE a Transiting Service Charge for the use of its Tandem Switching as specified in Attachment 14.

43.3.6.2 Until such time as AT&T and the third party LEC or ILEC agree upon mutual compensation, third party mutual compensation will be exchanged between AT&T and GTE as follows:

43.3.6.3 [Intentionally Deleted.]

43.3.6.4 [Intentionally Deleted.]

43.3.6.5 GTE will provide tandem switching at GTE access tandems for traffic between AT&T and GTE end offices subtending the GTE access tandem, as well as for traffic between AT&T and non-GTE end offices subtending GTE access tandems. By transporting traffic to a non-GTE end office(s) via a GTE tandem, AT&T assumes responsibility for compensation to GTE for all tandem switched traffic between AT&T and the non-GTE end office(s). This responsibility may be fulfilled either by payment by AT&T to GTE for all tandem switched traffic between AT&T and the non-GTE end office(s) or by an agreement between AT&T and the non-GTE end office LEC pursuant to which GTE is expressly made a third party beneficiary

and GTE would receive compensation from either AT&T or the non-GTE end office LEC, depending upon which entity originated the traffic. GTE will bill AT&T for each minute of use AT&T generates that is tandem switched.

- 43.3.6.6 By transporting traffic to non-GTE end offices via a GTE tandem, AT&T assumes responsibility for compensation to the non-GTE end office company. AT&T assumes responsibility for negotiating a compensation arrangement with the non-GTE end office for IntraLATA Toll Traffic terminating to AT&T from such third party LEC or ILEC.

In witness whereof, the Parties have executed this Agreement through their authorized representatives.

GTE North Incorporated

Contel of the South, Inc. d/b/a
GTE Systems of Michigan

By: _____
Signature

By: _____
Signature

Name

Name

Title

Title

Date

Date

AT&T Communications of Michigan, Inc.

By: _____
Signature

Name

Title

Date

ATTACHMENT 1
ALTERNATIVE DISPUTE RESOLUTION

TABLE OF CONTENTS

1. PURPOSE 1

2. EXCLUSIVE REMEDY 1

3. INFORMAL RESOLUTION OF DISPUTES 2

4. INITIATION OF AN ARBITRATION..... 3

5. GOVERNING RULES FOR ARBITRATION 3

6. APPOINTMENT AND REMOVAL OF ARBITRATOR..... 3

7. DUTIES AND POWERS OF THE ARBITRATOR..... 4

8. DISCOVERY..... 5

9. PRIVILEGES 5

10. LOCATION OF HEARING 5

11. DECISION 5

12. FEES 6

13. CONFIDENTIALITY..... 6

14. SERVICE OF PROCESS..... 6

Appendix 1 Procedures for Resolution of Service-Affecting Disputes

ALTERNATIVE DISPUTE RESOLUTION

1. Purpose

This Attachment 1 is intended to provide for the expeditious, economical, and equitable resolution of disputes between GTE and AT&T arising under this Agreement, and to do so in a manner that permits uninterrupted, high quality services to be furnished to each Party's customers.

2. Exclusive Remedy

2.1 Negotiation and arbitration under the procedures provided herein shall be the exclusive remedy for all disputes between GTE and AT&T arising out of this Agreement or its breach. GTE and AT&T agree not to resort to any court, agency, or private group with respect to such disputes except in accordance with this Attachment.

2.1.1 If, for any reason, certain claims or disputes are deemed to be non-arbitrable, the non-arbitrability of those claims or disputes shall in no way affect the arbitrability of any other claims or disputes.

2.1.2 If, for any reason, the FCC or any other federal or state regulatory agency exercises jurisdiction over and decides any dispute related to this Agreement or to any GTE Tariff and, as a result, a claim is adjudicated in both an agency proceeding and an arbitration proceeding under this Attachment 1, the following provisions shall apply:

2.1.2.1 To the extent required by law, the agency ruling shall be binding upon the parties for the limited purposes of regulation within the jurisdiction and authority of such agency.

2.1.2.2 The arbitration ruling rendered pursuant to this Attachment 1 shall be binding upon the parties for purposes of establishing their respective contractual rights and obligations under this Agreement, and for all other purposes not expressly precluded by such agency ruling.

2.1.3 Nothing in this Attachment 1 shall limit the right of either GTE or AT&T to obtain provisional remedies (including injunctive relief) from a court before, during or after the pendency of any arbitration proceeding brought pursuant to this Attachment 1. However, once a decision is reached by the Arbitrator, such decision shall supersede any provisional remedy.

3. **Informal Resolution of Disputes**

3.1 Prior to initiating an arbitration pursuant to the American Arbitration Association ("AAA") rules, as described below, the Parties to this Agreement shall submit any dispute between GTE and AT&T for resolution to an Inter-Company Review Board consisting of one representative from AT&T at the Director-or-above level and one representative from GTE at the Vice-President-or-above level (or at such lower level as each Party may designate). The dispute will be submitted by either Party giving written notice to the other Party, consistent with the notice requirements of this Agreement, that the Party intends to initiate the Informal Resolution of Disputes process. The notice shall define the dispute to be resolved. The Parties may use a mediator to help informally settle a dispute.

The initial representatives of each Party shall be as follows:

AT&T

Telephone: _____
Telecopier: _____

GTE

Telephone: _____
Telecopier: _____

A representative shall be entitled to appoint a delegee to act in his or her place as a Party's representative on the Inter-Company Review Board for any specific dispute brought before the Board.

3.2 The Parties may enter into a settlement of any dispute at any time. The Settlement Agreement shall be in writing, and shall identify how the Arbitrator's or mediator's fee for the particular proceeding, if any, will be apportioned.

3.3 At no time, for any purposes, may a Party introduce into evidence or inform the Arbitrator appointed under Section 6 below of any statement or other action of a Party in connection with negotiations between the Parties pursuant to the Informal Resolution of Disputes provision of this Attachment 1.

3.4 By mutual agreement, the Parties may agree to submit a dispute to mediation prior to initiating arbitration.

4. **Initiation of an Arbitration**

If the Inter-Company Review Board is unable to resolve a non-service affecting dispute within 30 days (or such longer period as agreed to in writing by the Parties) of such submission, and the Parties have not otherwise entered into a settlement of their dispute, the Parties shall initiate an arbitration in accordance with the AAA rules. Any dispute over a matter which directly affects the ability of a Party to provide high quality services to its customers will be governed by the procedures described in Appendix 1 to this Attachment 1.

5. **Governing Rules for Arbitration**

The rules set forth below and the rules of Commercial Arbitrations of the AAA shall govern all arbitration proceedings initiated pursuant to this Attachment; however, such arbitration proceedings shall not be conducted under the auspices of the AAA unless the Parties mutually agree. Where any of the rules set forth herein conflict with the rules of the AAA, the rules set forth in this Attachment shall prevail.

6. **Appointment and Removal of Arbitrator**

6.1 Within forty-five (45) days following the Effective Date of this Agreement the Parties will appoint three arbitrators, each of whom will have experience in the field of telecommunications. Each such Arbitrator shall serve for the full term of this Agreement, unless removed pursuant to Section 6.3 of this Attachment. Each of the three Arbitrators will be appointed by mutual agreement of the Parties in writing within the aforementioned forty-five day period. Each Arbitrator so appointed shall receive an assignment designation number (1, 2 or 3), and the Arbitrators shall be assigned in that sequence as disputes arise that are subject to this Attachment. In the event that any of the three initial Arbitrators so appointed resigns or is removed pursuant to Section 6.3 of this Attachment, or becomes unable to discharge his or her duties, the Parties shall, by mutual written agreement, appoint a replacement Arbitrator within thirty (30) days after the date of such resignation, removal or disability. All matters pending before the departing Arbitrator shall be reassigned as provided in Section 6.4 of this Attachment; provided however that such matters shall not be assigned to the replacement Arbitrator. New matters will be assigned the replacement Arbitrator in accordance with the procedure set forth herein (above).

6.2 For each dispute properly submitted for arbitration under this Attachment, the Parties shall assign a sole Arbitrator from among the three Arbitrators

appointed under Section 6.1 in accordance with the assignment sequence described therein. Each such assignment shall be made within ten (10) days of the expiration under Section 4 of this Attachment of the Inter-Company Review Board review period. Insofar as common issues arise concerning more than one Interconnection, Resale and Unbundling Agreement signed between an AT&T Affiliate and a GTE Affiliate, the Parties agree that such common issues will be combined and submitted to the same Arbitrator for resolution.

6.3 The Parties may, by mutual written agreement, remove an Arbitrator at any time, and shall provide prompt written notice of removal to such Arbitrator. Notwithstanding the foregoing, any Arbitrator may be removed at any time unilaterally by either Party as permitted in the rules of the AAA. Furthermore, upon (30) days' prior written notice to the Arbitrator and to the other Party, a Party may remove an Arbitrator with respect to future disputes which have not been submitted to arbitration in accordance with the requirements of Section 4 of this Attachment 1, as of the date of such notice.

6.4 In the event that an Arbitrator resigns or is removed pursuant to Section 6.3 of this Attachment, or becomes unable to discharge his or her duties, or is otherwise unavailable to perform the duties of Arbitrator, any matters then pending before that departing or disabled Arbitrator will be assigned to the incumbent Arbitrator with the next assignment designation number (in ascending order). Such assignment will be made effective by written notice of the Parties to be provided within ten days following the resignation, removal or unavailability that necessitates such reassignment.

6.5 In the event that the Parties do not appoint an Arbitrator or replacement Arbitrator within the time periods prescribed in Section 6.1 of this Attachment 1, either Party may apply to AAA for appointment of such Arbitrator. Prior to filing an application with the AAA, the Party filing such application shall provide ten (10) days' prior written notice to the other Party to this Agreement.

7. **Duties and Powers of the Arbitrator**

7.1 The Arbitrator shall receive complaints and other permitted pleadings, oversee discovery, administer oaths and subpoena witnesses pursuant to the United States Arbitration Act, hold hearings, issue decisions, and maintain a record of proceedings. The Arbitrator shall have the power to award any remedy or relief that a court with jurisdiction over this Agreement could order or grant, including, without limitation, the awarding of damages, pre-judgment interest, specific performance of any obligation created under the Agreement, issuance of an injunction, or imposition of sanctions for abuse or frustration of the arbitration process, except that the Arbitrator may not award punitive damages or any remedy rendered

unavailable to the Parties pursuant to Section 10.3 of the General Terms and Conditions of this Agreement.

7.2 The Arbitrator shall not have the authority to limit, expand, or otherwise modify the terms of this Agreement.

8. **Discovery**

GTE and AT&T shall attempt, in good faith, to agree on a plan for document discovery. Should they fail to agree, either GTE or AT&T may request a joint meeting or conference call with the Arbitrator. The Arbitrator shall resolve any disputes between GTE and AT&T, and such resolution with respect to the scope, manner, and timing of discovery shall be final and binding.

9. **Privileges**

Although conformity to certain legal rules of evidence may not be necessary in connection with arbitrations initiated pursuant to this Attachment, the Arbitrator shall, in all cases, apply the attorney-client privilege and the work product immunity doctrines.

10. **Location of Hearing**

Unless both Parties agree otherwise, any hearings shall take place in Dallas, Texas.

11. **Decision**

11.1 Except as provided below, the Arbitrator's decision and award shall be final and binding, and shall be in writing and shall set forth the Arbitrator's reasons therefor for decision unless the Parties mutually agree to waive the requirement of a written opinion. Judgment upon the award rendered by the Arbitrator may be entered in any court having jurisdiction thereof. Either Party may apply to the United States District Court for the district in which the hearing occurred for an order enforcing the decision.

11.2 A decision of the Arbitrator shall not be final in the following situations:

- a) a Party appeals the decision to the Commission or FCC, and the matter is within the jurisdiction of the Commission or FCC, provided that the agency agrees to hear the matter;
- b) the dispute concerns the misappropriation or use of intellectual property rights of a Party, including, but not limited to, the use of the trademark, tradename, trade dress or service mark of a Party, and the decision appealed by a

Party to a federal or state court with jurisdiction over the dispute.

11.3 Each Party agrees that any permitted appeal must be commenced within thirty (30) days after the Arbitrator's decision in the arbitration proceedings is issued. In the event of an appeal, a Party must comply with the results of the arbitration process during the appeal process.

12. **Fees**

Unless otherwise mutually agreed in writing, each Arbitrator's fees and expenses shall be shared equally between the Parties, provided, however, that in the arbitration of any particular dispute either Party may request that all fees and expenses directly related to that arbitration matter be imposed on the other Party, and the Arbitrator shall have the power to grant such relief, in whole or in part.

13. **Confidentiality**

13.1 GTE, AT&T, and the Arbitrator will treat the arbitration proceeding, including the hearings and conferences, discovery, or other related events, as confidential, except as necessary in connection with a judicial challenge to, or enforcement of, an award, or unless otherwise required by an order or lawful process of a court or governmental body.

13.2 In order to maintain the privacy of all arbitration conferences and hearings, the Arbitrator shall have the power to require the exclusion of any person, other than a Party, counsel thereto, or other essential persons.

13.3 To the extent that any information or materials disclosed in the course of an arbitration proceeding contains proprietary or confidential Information of either Party, it shall be safeguarded in accordance with Section 17 of this Agreement. However, nothing in Section 17 of this Agreement shall be construed to prevent either Party from disclosing the other Party's Information to the Arbitrator in connection with or in anticipation of an arbitration proceeding. In addition, the Arbitrator may issue orders to protect the confidentiality of proprietary information, trade secrets, or other sensitive information.

14. **Service of Process**

14.1 Service may be made by submitting one copy of all pleadings and attachments and any other documents requiring service to each Party and one copy to the Arbitrator. Service shall be deemed made (i) upon receipt if delivered by hand; (ii) after three (3) business days if sent by first class

certified U.S. mail; (iii) the next business day if sent by overnight courier service; (iv) upon confirmed receipt if transmitted by facsimile. If service is by facsimile, a copy shall be sent the same day by hand delivery, first class U.S. mail, or overnight courier service.

- 14.2 Service by AT&T to GTE and by GTE to AT&T at the address designated for delivery of notices in this Agreement shall be deemed to be service to GTE or AT&T, respectively. The initial address for delivery of notices is specified in Subsection 3 above.

Appendix I to Attachment 1

ALTERNATIVE DISPUTE RESOLUTION

Procedure for Resolution of Service-Affecting Disputes

1. Purpose.

This Appendix 1 describes the procedures for an expedited resolution of disputes between GTE and AT&T arising under this Agreement which directly affect the ability of a Party to provide uninterrupted, high quality services to its customers and which cannot be resolved using the procedures for informal resolution of disputes contained in Attachment 1 to the Agreement.

Except as specifically provided in this Appendix 1 to Attachment 1, the provisions of Attachment 1 shall apply.

2. Initiation of an Arbitration.

- a) If the Inter-Company Review Board is unable to resolve a service affecting dispute within two (2) business days (or such longer period as agreed to in writing by the Parties) of such submission, and the Parties have not otherwise entered into a settlement of their dispute, a Party may initiate an arbitration in accordance with the requirements of this Appendix 1 to Attachment 1. However, in the sole discretion of the Party which submitted the dispute to the Inter-Company Review Board, the dispute may be arbitrated in accordance with the general procedures described in Attachment 1 rather than the expedited procedures of this Appendix 1 to Attachment 1.
- b) A proceeding for arbitration will be commenced by a Party ("Complaining Party") filing a complaint with the Arbitrator and simultaneously serving a copy on the other Party ("Complaint").
- c) Each Complaint will concern only the claims relating to an act or failure to act (or series of related acts or failures to act) of a Party which affect the Complaining Party's ability to offer a specific service (or group or related services) to its customers.

A Complaint may be in letter or memorandum form and must specifically describe the action or inaction of a Party in dispute and identify with particularity how the complaining Party's service to its customers is affected.

3. Response to Complaint.

A response to the Complaint must be filed within five (5) business days after service of the Complaint.

4. Reply to Complaint.

A reply is permitted to be filed by the Complaining Party within three (3) business days of service of the response. The reply must be limited to those matters raised in the response.

5. Discovery.

The Parties shall cooperate on discovery matters as provided in Section 8 of Attachment 1, but following expedited procedures.

6. Hearing.

- a) The Arbitrator will schedule a hearing on the Complaint to take place within twenty (20) business days after service of the Complaint. However, if mutually agreed to by the parties, a hearing may be waived and the decision of the Arbitrator will be based upon the papers filed by the Parties.
- b) The hearing will be limited to four (4) days, with each Party allocated no more than two (2) days, including cross examination by the other Party, to present its evidence and arguments. For extraordinary reasons, including the need for extensive cross-examination, the Arbitrator may allocate more time for the hearing.

In order to focus the issues for purposes of the hearing, to present initial views concerning the issues, and to facilitate the presentation of evidence, the Arbitrator has the discretion to conduct a telephone prehearing conference at a mutually convenient time, but in no event later than three (3) days prior to any scheduled hearing.

Each Party may introduce evidence and call witnesses it has previously identified in its witness and exhibit lists. The witness and exhibit lists must be furnished to the other Party at least three (3) days prior to commencement of the hearing. The witness list will disclose the substance of each witness' expected testimony. The exhibit list will identify by name (author and recipient), date, title and any other identifying characteristics the exhibits to be used at the arbitration.

Testimony from witnesses not listed on the witness list or exhibits not listed on the exhibit list may not be presented in the hearing.

- c) The parties will make reasonable efforts to stipulate to undisputed facts prior to the date of the hearing.

- d) Witnesses will testify under oath and a complete transcript of the proceeding, together with all pleadings and exhibits, shall be maintained by the Arbitrator.

7. Decision.

- a) The Arbitrator will issue and serve his or her decision on the Parties within five (5) business days of the close of the hearing or receipt of the hearing transcript, whichever is later.
- b) The Parties agree to take the actions necessary to implement the decision of the Arbitrator immediately upon receipt of the decision.

ATTACHMENT 2**SERVICE DESCRIPTION: UNBUNDLED NETWORK ELEMENTS****TABLE OF CONTENTS**

1. <u>INTRODUCTION</u>	1
2. <u>NETWORK INTERFACE DEVICE</u>	1
3. <u>LOOP</u>	4
4. <u>LOCAL SWITCHING</u>	10
5. <u>OPERATOR SERVICES</u>	18
6. <u>DIRECTORY ASSISTANCE SERVICE</u>	20
7. <u>COMMON TRANSPORT</u>	21
8. <u>DEDICATED TRANSPORT</u>	22
9. <u>SIGNALING LINK TRANSPORT</u>	31
10. <u>SIGNALING TRANSFER POINTS (STPS)</u>	32
11. <u>SERVICE CONTROL POINTS/DATABASES</u>	35
12. <u>TANDEM SWITCHING</u>	45
13. <u>ADDITIONAL REQUIREMENTS</u>	49
14. <u>UNUSED TRANSMISSION MEDIA</u>	75

SERVICE DESCRIPTION: UNBUNDLED NETWORK ELEMENTS

1. **Introduction**

This Attachment sets forth the descriptions and requirements for unbundled network elements that GTE agrees to offer to AT&T under this Agreement. To the extent sections contained in this Attachment and Appendix A to this Attachment set forth technical references, technical standards, technical requirements and/or performance standards. GTE's obligation to comply with such references, requirements, and/or standards shall be subject to Section 23.19 of the General Terms and Conditions of this Agreement.

2. **Network Interface Device**

2.1. **Definition:**

The Network Interface Device (NID) is a single-line termination device or that portion of a multiple-line termination device required to terminate a single line or circuit. The fundamental function of the NID is to establish the official network demarcation point between a carrier and its end-user customer. The NID generally features two independent chambers or divisions which separate the service provider's network from the customer's inside wiring. Each chamber or division contains the appropriate connection points or posts to which the service provider, and the end-user customer each make their connections. The NID provides a protective ground connection, and is capable of terminating cables such as twisted pair cable. The NID may be ordered as a Network Element independently from the Loop Distribution.

2.1.1. With respect to multiple-line termination devices, AT&T shall specify the quantity of NIDs it requires within such device.

Figure 1 - Network Interface Device [Intentionally Deleted]

2.1.2. **Technical References (subject to Section 23.19 of the General Terms and Conditions of this Agreement):**

2.1.2.1. The Network Interface Device shall provide a clean, accessible point of connection for the inside wiring and for the Distribution Media and shall maintain a connection to ground that meets the references set forth below.

- 2.1.2.2. The NID shall be capable of transferring electrical analog or digital signals between the customer's inside wiring and the Distribution Media.
- 2.1.2.3. All NID posts or connecting points shall be in place, secure, usable and free of any rust or corrosion. The protective ground connection shall exist and be properly installed. The ground wire will also be free of rust or corrosion and have continuity relative to ground.
- 2.1.2.4. The NID shall be capable of withstanding all normal local environmental variations.
- 2.1.2.5. Where the NID is not located in a larger, secure cabinet or closet, the NID shall be protected from physical vandalism. The NID shall be physically accessible to AT&T designated personnel and GTE will identify the cable pair used for the particular service which will be replaced by AT&T. In cases where entrance to the customer premises is required to give access to the NID, AT&T shall obtain entrance permission directly from the customer.
- 2.1.2.6. [Intentionally Deleted]
- 2.1.3. Interface References (subject to Section 23.19 of the General Terms and Conditions of this Agreement):
- 2.1.3.1. AT&T shall be permitted to connect its own Loop directly to GTE's Network Interface Device (NID) in cases in which AT&T uses its own facilities to provide local service to an end user formerly served by GTE, as long as such direct connection does not adversely affect GTE's network. In order to minimize any such adverse effects, AT&T shall follow the procedures in sub-sections 2.1.3.2 and 2.1.3.3.
- The NID will be made available to AT&T as a separate unbundled network element to which AT&T will connect their own loop. GTE will not require that a separate NID be installed by AT&T to make a NID to NID connection as required in the FCC First Report and Order. AT&T will assume responsibility for ensuring that the proper over voltage protection is maintained to protect the customer premise.
- 2.1.3.2. When connecting its own loop facility directly to GTE's NID for a residence or business customer, AT&T must make a clean cut on the GTE drop wire at the NID so that no bare wire is exposed. AT&T shall not remove or disconnect GTE's drop wire from the NID

or take any other action that might cause GTE's drop wire to be left lying on the ground.

- 2.1.3.3. At multi-tenant customer locations, AT&T must remove the jumper wire from the distribution block (i.e. the NID) to the GTE cable termination block. If AT&T cannot gain access to the cable termination block, AT&T must make a clean cut at the closest point to the cable termination block. At AT&T's request and discretion, GTE will determine the cable pair to be removed at the NID in multi-tenant locations. AT&T will compensate GTE for the trip charge necessary to identify the cable pair to be removed.
- 2.1.3.4. GTE agrees to offer NIDs for lease to AT&T, but not for sale. AT&T may remove GTE identification from any NID which it connects to an AT&T loop, but AT&T may not place its own identification on such NID.
- 2.1.3.5. NID to NID Connection. GTE will not require that a separate NID be installed by AT&T in order to make a NID to NID connection. Rather than connecting its loop directly to GTE's NID, AT&T may also elect to install its own NID and effect a NID to NID connection to gain access to the end user's inside wiring.
- 2.1.3.6. Removal of Cable Pairs. Removal from the NID of existing cable pairs required for AT&T to terminate service is the responsibility of AT&T.
- 2.1.3.7. Maintenance / Liability. Sub-paragraphs 2.1.3.8 through 2.1.3.11 outline AT&T's responsibilities when leasing NIDs from GTE.
- 2.1.3.8. GTE is responsible for the maintenance of the NID when it is leased as part of the unbundled loop.
- 2.1.3.9. GTE is not responsible for any damage to AT&T's customer's interior wiring, station apparatus, or physical harm to the dwelling or persons resulting from over-voltage intrusion from AT&T's cable facilities.
- 2.1.3.10. When AT&T no longer wishes to lease the GTE NID, AT&T is responsible for ensuring that this equipment is left in proper working order.
- 2.1.3.11. When AT&T discontinues the use of the NID, GTE will perform a physical inspection of the NID prior to reconnection to a GTE customer and charge AT&T for any corrective maintenance which may be required.

2.1.4. The Network Interface Device shall be provided to AT&T in accordance with the technical references listed in Appendix A, under paragraph 1.

3. **Loop**

3.1. **Definition:**

A "Loop" is a transmission facility between the main distribution frame (cross-connect), or functionally comparable piece of equipment in a GTE end office or wire center to a demarcation, connector block or network interface device at a customer's premises. Loop types typically include, but are not limited to, two-wire and four-wire copper analog voice-grade loops, two-wire and four-wire loops that are conditioned to transmit analog and digital signals, needed to provide, for example, ISDN, ADSL, HDSL, and DS-1 level signals, DS-1 loops, Coax loops and Fiber loops. A Loop is composed of the following Sub-Loop Elements, to the extent that each is physically existent in the LEC network where the Loop is ordered and the Network Interface Device (NID). The Sub-Loop Elements are defined in detail below:

Loop Distribution Media

Loop Concentrator/Multiplexer

Loop Feeder

3.1.1. **Technical References (subject to Section 23.19 of the General Terms and Conditions of this Agreement):**

3.1.1.1. Basic Loop. The Basic Loop is a 2-wire copper facility or functional equivalent which will meet industry standard specifications for Voice Frequency transmission. The Basic Loop may include load coils, bridge taps, etc., or may include carrier derived facility components (i.e. pair gain applications, loop concentrator/multiplexers). The Basic Loop will be designed within industry design parameters with a loop loss (from customer to MDF) which does not exceed 10 dB and with a noise level less than 30 dbrnC. For loaded loops, the Bridge Tap and End section will be between 3 and 12 kFt.

3.1.1.2. Special Conditioning Requirements. The Basic Loop will be provided to AT&T at parity with GTE customers and will, subject to Section 23.19 of the General Terms and Conditions of this Agreement, comply with the specifications noted in this Section 3.1, Loop. Transmission of signaling messages or tones not provided by these specifications will be provided to AT&T, as

agreed between AT&T and GTE. When placing an order for unbundled Loop and Sub-Loop elements, AT&T will notify GTE of any special requirements. Special conditioning to provide such requirements will be provided on a case-by-case basis, if Currently Available. AT&T agrees to bear the cost of any such special conditioning. Types of Loops which may require such conditioning include 2W/4W PABX Trunks, 2W/4W voice grade private line and foreign exchange lines, 4W digital data (2.4Kbps through 64Kbps), etc.

- 3.1.1.3. ISDN BRI Loops. Upon request by AT&T, GTE will provide where Currently Available, 2W loops capable of transmitting ISDN data rates as it provides to its own ISDN customers.
- 3.1.1.4. 4-Wire DS-1 Loops/ISDN PRI. These Loops will be designed to support a digital transmission rate of 1,544, 000 bps. These Loops will be designed within industry parameters and have no bridge taps or load coils. These Loops will employ special line treatment (span line repeaters, office terminating repeaters at the GTE wire center, or similar technology).
- 3.1.1.5. Features, Functions, Attributes, Etc. To the degree Currently Available, all transport-based features, functions, service attributes, grades-of-service, installation, maintenance and repair intervals that apply to the bundled services, will apply to the above unbundled Loop.
- 3.1.1.6. All Loop facilities furnished by GTE on the premises of AT&T's end users and up to the network interface or functional equivalent are the property of GTE. GTE must have access to all such facilities for network management purposes. GTE employees and agents may enter said premises at any reasonable hour to test and inspect such facilities in connection with such purposes or, upon termination or cancellation of the Loop facility, to remove such facility.
- 3.1.1.7. If AT&T leases Loops which are conditioned to transmit digital signals, as a part of that conditioning, GTE will test the Loop after conditioning and provide recorded test results to AT&T. When AT&T provides its own switching, it will test the unbundled loops. If there is a maintenance problem on an unbundled loop, AT&T will report the problem to GTE, and GTE will be responsible for the repair of the loop. In maintenance and repair cases, if loop tests are taken, GTE will provide any recorded readings to AT&T at the time the trouble ticket is closed in the same manner as GTE provides to itself and its end users.

- 3.1.1.8. AT&T may order an unbundled Loop provided over copper facility even in instances where the Loop for services that GTE offers is other than a copper facility.
- 3.1.2. Unbundled Loop Facility Certification
- 3.1.2.1. Before deploying any service enhancing copper cable technology (e.g., HDSL, ISDN, etc.) over unbundled 2-wire analog voice grade loops provided by GTE, AT&T shall notify GTE of such intentions to enable GTE to assess the loop transport facilities to determine whether there are any existing copper cable loop transport technologies (e.g., analog carrier, etc.) deployed within the same cable sheath that would be interfered with if AT&T deployed the proposed service enhancing copper cable technology. If there are existing copper cable loop transport technologies already deployed within the same cable sheath, or if GTE already has specific planned projects to deploy copper cable loop transport technologies within the next six months for which it can demonstrate a specific commitment by producing detailed engineering plans, GTE will so inform AT&T and AT&T shall not be permitted to deploy such service enhancing copper cable technologies.
- 3.1.2.1.1. If AT&T fails to notify GTE of its plans to deploy service enhancing copper cable technology and obtain prior certification from GTE of the facilities, and if AT&T's deployment of such technology is determined to have caused interference with existing or planned copper cable loop transport technologies deployed by GTE in the same cable sheath, AT&T will immediately remove such service enhancing copper cable technology and shall reimburse GTE for all incurred expense related to this interference.
- 3.1.2.2. Prior to GTE deploying service enhancing copper cable technology, as described above, GTE will validate, through a search of its facility assignment records, that AT&T has not deployed technologies within the same cable sheath that would be interfered by those planned by GTE. Should such incompatibility exist, GTE will not deploy such technology that would interfere with those already deployed by AT&T.
- 3.1.2.2.1. Should GTE deploy service enhancing copper cable technology which is determined to interfere with technology previously deployed by AT&T, and AT&T can demonstrate that they had complied with GTE's Unbundled Loop Facility Certification procedure, GTE will remove their technology from the cable

sheath, reimburse AT&T for all incurred expenses related to this interference.

3.1.3. Unbundled Loop Facility Reservation. GTE and AT&T may each reserve for up to 6 (six) months the right to deploy within GTE's network copper cable loop transport technology for specific projects for which a party can demonstrate a specific commitment by producing detailed engineering plans.

3.1.4. Technical References(subject to Section 23.19 of the General Terms and Conditions of this Agreement):

Specific Loops as described in 3.1.1.1 through 3.1.1.4 are capable of transmitting signals for the following services (as needed by AT&T to provide end-to-end service capability to its end-user customer):

1. 2-wire voice grade basic telephone services
2. 2-wire ISDN
3. 2-wire Centrex
4. 2 and 4-wire PBX lines or trunks
5. 2 and 4-wire voice grade private lines and foreign exchange lines
6. 4-wire digital data (2.4kbps through 64Kbps and n times 64Kbps) (where $n < 24$)
7. 4-wire DS1 (switched or private line)

3.1.5. Additional technical references for Loop Where Integrated Digital Loop Carrier Systems are being used. If GTE uses Integrated Digital Loop Carrier (DLCs) systems to provide local loop, GTE will make alternative arrangements to permit AT&T to order a contiguous unbundled Loop. These arrangements may include the following: provide AT&T with copper facilities or universal DLC that are acceptable to AT&T, deploy Virtual Remote Terminals, allow AT&T to purchase the entire Integrated DLC, or convert integrated DLCs to non-integrated systems.

3.2. **Loop Distribution Media**

3.2.1. Definition:

Loop Distribution Media provides connectivity between the NID and the terminal block on the customer-side of a Feeder Distribution Interface (FDI). The FDI is a device that terminates the Loop Distribution Media and the Loop Feeder, and cross-connects them

in order to provide a continuous transmission path between the NID and a telephone company central office.

- 3.2.1.1. In some instances, AT&T may request and GTE will provide, to the extent Currently Available, a copper twisted pair Distribution Media in instances where the Loop Distribution Media for services that GTE offers is other than a copper facility.
- 3.2.2. GTE will provide to AT&T Loop Distribution Media of the same condition that exists for the current GTE customer.
- 3.2.3. GTE is not responsible for the end to end performance of the entire loop when GTE provides only the Loop Distribution Media.
- 3.2.4. The Loop Distribution Media provided under this Agreement shall meet or exceed the applicable interface references set forth in the technical references listed in Appendix A to this Attachment 2 under paragraph 2 thereof.
- 3.2.5. The Loop Distribution Media may be ordered by AT&T through the Bona Fide Request procedures outlined in Attachment 12. The request shall specify the technical requirements for the Loop Distribution Media.
- 3.2.6. GTE shall perform all cross connections to the FDI as AT&T may request from time to time in order to provide Network Elements to AT&T in accordance with this Agreement. Since GTE will be performing all necessary cross connections within the FDI and at the main distribution frame, AT&T agrees that there will be no requirement for personnel of AT&T to access the FDI or the serving wire center to the extent that AT&T has no equipment collocated in the GTE central office.
- 3.2.7. AT&T shall be responsible for the costs (if any) required to create an interface at the main distribution frame if such interface does not already exist, such as in the case of an Integrated Digital Loop Carrier System, as specified in Attachment 14.

3.3. **Loop Concentrator/Multiplexer**

3.3.1. **Definition:**

The Loop Concentrator/Multiplexer is the Network Element that: (1) aggregates lower bit rate or bandwidth signals to higher bit rate or bandwidth signals (multiplexing); (2) disaggregates higher bit rate or bandwidth signals to lower bit rate or bandwidth signals

(demultiplexing); (3) aggregates a specified number of signals or channels to fewer channels (concentrating); (4) performs signal conversion, including encoding of signals (e.g., analog to digital and digital to analog signal conversion); and (5) in some instances performs electrical to optical (E/O) conversion.

The Loop Concentrator/Multiplexer function will be provided through a Digital Loop Carrier (DLC) system, channel bank, multiplexer or other equipment at which traffic is encoded and decoded, multiplexed and demultiplexed, or concentrated.

3.3.2. GTE is not responsible for the end to end performance of the entire loop when GTE provides only the Loop Concentrator/Multiplexer.

3.3.3. The Loop Concentrator/Multiplexer provided under this Agreement shall, subject to Section 23.19 of the General Terms and Conditions of this Agreement, meet or exceed the applicable interface references set forth in Appendix A to this Attachment 2, under paragraph 2 thereof.

3.3.4. The Loop Concentrator/Multiplexer may be ordered by AT&T through the Bona Fide Request procedures outlined in Attachment 12. The request shall specify the technical requirements for the Loop Concentrator/Multiplexer.

3.4. **Loop Feeder**

3.4.1. Definition:

3.4.2. The Loop Feeder is the Network Element that provides connectivity between (1) a FDI associated with Loop Distribution Media and a termination point appropriate for the media in a central office, or (2) a Loop Concentrator/Multiplexer provided in a remote terminal and a termination point appropriate for the media in a central office. Since GTE will be performing all necessary cross connections within the FDI and the main distribution frame, there will be no requirement for personnel of AT&T to access the FDI or the serving wire center to the extent that AT&T has no equipment collocated in the GTE central office.

3.4.3. In certain cases, AT&T may request and GTE will provide to the extent Currently Available a copper twisted pair loop even in instances where the medium of the Loop Feeder for services that GTE offers is other than a copper facility.

- 3.4.4. The Loop Feeder provided under this Agreement shall meet or exceed the applicable interface technical references listed in Appendix A to this Attachment 2, under paragraph 2 thereof.
- 3.4.5. The Loop Feeder may be ordered by AT&T through the Bona Fide Request procedures outlined in Attachment 12. The request shall specify the technical requirements for the Loop Feeder.
- 3.4.6. GTE is not responsible for the end performance of the entire loop when GTE provides only the Loop Feeder.
- 3.5. Other Sub-Loop Terms and Conditions
- 3.5.1. GTE agrees to provide access to the sub-loop network elements at the Feeder Distribution Interface (FDI), based on the following conditions:
- 3.5.2. AT&T agrees to pay GTE to expand or replace the FDI (over and above the established price of the basic loop) to accommodate terminating the new AT&T cable.
- 3.5.3. AT&T agrees to pay GTE an agreed upon charge to perform all cross connections within the GTE FDI (in addition to the price of the basic sub-loop network element(s) leased by AT&T).
- 3.5.4. AT&T agrees that since all cross connects will be performed by GTE personnel, AT&T personnel will not require access to the FDI.

4. **Local Switching**

- 4.1. **Definition:**
Local Switching is the Network Element that provides the functionality required to connect the appropriate originating lines or trunks wired to the Main Distributing Frame (MDF) or Digital Signal Cross Connect (DSX) panel to a desired terminating line or trunk. Such functionality shall include all of the features, functions, and capabilities of the GTE switch including but not limited to: line signaling and signaling software, digit reception, dialed number translations, call screening, routing, recording, call supervision, dial tone, switching, telephone number provisioning, announcements, calling features and capabilities (including call processing), CENTRANET, Automatic Call Distributor (ACD), Carrier pre-subscription (e.g., long distance carrier, intraLATA toll), Carrier Identification Code (CIC) portability capabilities, testing and other operational features inherent to the switch and switch software. Local Switching provides access to transport, signaling

(ISDN User Part (ISUP) and Transaction Capabilities Application Part (TCAP), and platforms such as adjuncts, Public Safety Systems (911), operator services, directory services and Advanced Intelligent Network (AIN). Remote Switching Module functionality is included in the Local Switching function. The switching capabilities used will be based on the line side features they support, where Currently Available. Local Switching will also be capable of routing local directory assistance and operator services calls to alternative directory assistance and operator services platforms.

- 4.1.1. Where Currently Available Local Switching also includes Data Switching, which provides for ISDN Packet and Circuit Switched Data service, the data switching functionality that is required to connect between industry standard ISDN interfaces. In this case, the purpose of Data Switching is to terminate, concentrate, and switch data traffic from Customer Premises Equipment (CPE) in the digital format consistent with ISDN standards. Data Switching also provides connectivity for the purpose of conveying the customer data to its final destination.
- 4.2. **Technical References** (subject to Section 23.19 of the General Terms and Conditions of this Agreement):
The technical references set forth in this Section 4.2 apply to Local Switching.
 - 4.2.1. GTE shall offer to AT&T unbundled access to all facilities, functions, features and capabilities of its local switches to the extent each such facility, function, feature or capability is Currently Available within the applicable switch and GTE has the right to use such facility, function, feature or capability.
 - 4.2.1.1. Where Currently Available, GTE shall offer Local Switching together with and separately from Data Switching.
 - 4.2.1.2. When applicable, GTE shall route calls to the appropriate trunk or lines for call origination or termination.
 - 4.2.1.3. GTE shall route local directory assistance and operator services calls on a per line or per screening class basis to (1) GTE platforms providing Network Elements or additional requirements, (2) AT&T designated platforms, or (3) third-party platforms.

- 4.2.1.4. GTE shall provide standard recorded announcements as designated by AT&T and call progress tones to alert callers of call progress and disposition.
- 4.2.1.5. GTE shall activate service for an AT&T Customer or network interconnection on any of the Local Switching interfaces. This includes provisioning changes to change a customer from GTE's services to AT&T's services without loss of feature functionality.
- 4.2.1.6. GTE shall perform routine testing (e.g., Mechanized Loop Tests (MLT) and test calls such as 105, 107 and 108 type calls) and fault isolation on a mutually agreed to schedule where such testing is Currently Available.
- 4.2.1.7. GTE shall repair and restore any equipment or any other maintainable component owned by or under the control of GTE that may adversely impact Local Switching.
- 4.2.1.8. GTE shall control congestion points such as those caused by radio station call-ins, and network routing abnormalities, using capabilities such as Automatic Call Gapping, Automatic Congestion Control, and Network Routing Overflow.
- 4.2.1.9. GTE shall perform call trace (manual or otherwise) consistent with the other provisions of testing, maintenance and repair sections of this Agreement (including, but not limited to Attachments 2, 4 and 5 to this Agreement). GTE shall permit customer originated call trace in accordance with Attachment 9 to this Agreement.
- 4.2.1.10. GTE shall record billable events and send the appropriate billing data to AT&T as outlined in Attachment 6.
- 4.2.1.11. For Local Switching used as 911 Tandems, GTE shall allow interconnection from AT&T local switching elements and GTE shall route the calls to the appropriate Public Safety Access Point (PSAP).
- 4.2.1.12. GTE shall provide where the switch is capable, each of the following capabilities:
- 4.2.1.13. Essential Service Lines;
- 4.2.1.14. Telephone service prioritization;
- 4.2.1.15. Telephone Relay Services for handicapped;

- 4.2.1.16. Soft dial tone where required by law; and
- 4.2.1.17. Any other capability required by law.
- 4.2.1.18. GTE shall provide Switching Service Point (SSP) capabilities and signaling software to interconnect the signaling links destined to the Signaling Transfer Point Switch (STPS). In the event that Local Switching is provided out of a switch without SS7 capability, the Tandem shall provide this capability as discussed in the section on Tandem Switching. These capabilities shall adhere to Bellcore specifications - TCAP (GR-1432-CORE), ISUP (GR-905-CORE), Call Management (GR-1429-CORE), Switched Fractional DS1 (GR-1357-CORE), Toll Free Service (GR-1428-CORE), Calling Name (GR-1597-CORE), Line Information Database (GR-954-CORE), and Advanced Intelligent Network (GR-2863-CORE). A further description of AIN is set forth in Sections 4.2.1.26.1 and 4.2.1.26.2 of this Attachment 2.
- 4.2.1.19. GTE shall provide interfaces to adjuncts through industry standard and Bellcore interfaces. These adjuncts can include, but are not limited to, the Service Circuit Node and Automatic Call Distributors. Examples of existing interfaces are ANSI ISDN standards Q.931 and Q.932.
- 4.2.1.20. GTE shall provide performance data regarding a customer line, traffic characteristics or other measurable elements to AT&T to the extent that it provides that information to itself.
- 4.2.1.21. GTE shall offer Local Switching that provides feature offerings at parity to those provided by GTE to itself or any other party. Such feature offerings, where available, shall generally include but not be limited to:
- 4.2.1.22. Basic and primary rate ISDN;
- 4.2.1.23. Residential features;
- 4.2.1.24. Customer Local Area Signaling Services (CLASS/LASS);
- 4.2.1.25. CENTRANET (including equivalent administrative capabilities, such as customer accessible reconfiguration and detailed message recording); and
- 4.2.1.26. Advanced intelligent network triggers supporting AT&T features. GTE shall offer to AT&T all subscribed or end-user specific AIN triggers to the extent technically feasible, and Currently Available

to GTE for offering AIN-based services in accordance with the applicable technical references listed in Appendix A to this Attachment 2, under paragraph 3 thereof, subject to Section 23.19 of the General Terms and Conditions of this Agreement.

- 4.2.1.26.1. When AT&T utilizes GTE's Local Switching network element and requests GTE to provision such network element with a Currently Available subscribed or end end-user specific AIN trigger, GTE will provide access to the appropriate AIN Call Related Database for the purpose of invoking either a GTE AIN feature or an AIN feature developed by AT&T through use of GTE's SCE/SMS under Section 11.7 below, provided, however, that GTE is not required to allow SS7 advanced intelligent access from AT&T's SCP to GTE's switch to invoke an AT&T-developed AIN feature, until testing and security concerns regarding the reliability of service to GTE's end users have been addressed, either through industry forums or successful testing.
- 4.2.1.26.2. When AT&T utilizes its own local switch, GTE will provide access to the appropriate AIN Call Related Database for the purpose of invoking either a GTE AIN feature or an AIN feature developed by AT&T through use of GTE's SCE/SMS under Section 11.7 below, provided, however, that GTE is not required to allow such use until testing and security concerns regarding the reliability of service to GTE's end users have been addressed, either through industry forums or successful testing.
- 4.2.1.27. Upon AT&T's request, GTE shall assign each AT&T Customer line the class of service designated by AT&T (e.g., using line class codes or other switch specific provisioning methods), and shall terminate Directory Assistance traffic onto the dedicated AT&T trunks previously identified by AT&T for this purpose.
- 4.2.1.28. Upon AT&T's request, GTE shall assign each AT&T Customer line the class of services designated by AT&T (e.g., using line class codes or other switch specific provisioning methods) and shall route operator calls from AT&T Customer to AT&T operators at AT&T's option. Where technically feasible, GTE shall route local Operator Services calls (0+, 0-) dialed by AT&T Customers directly to the AT&T Local Operator Services platform, unless AT&T requests otherwise pursuant to Section 28.7.1. Such traffic shall be routed over trunk groups specified by AT&T which connect GTE end offices and the AT&T Local Operator Services platform, using standard Operator Services dialing protocols of 0+ or 0-. Where intraLATA presubscription is not available, GTE will provide the functionality and features within its local switch (LS), to route AT&T

Customer dialed 0- and 0+ IntraLATA calls to the AT&T designated line or trunk on the Main Distributing Frame (MDF) or Digital Cross Connect (DSX) panel via Modified Operator Services (MOS) Feature Group C signaling. Where IntraLATA presubscription is available, AT&T Customer dialed 0- and 0+ intraLATA calls will be routed to the intraLATA PIC carrier's designated operator services platform. In all cases, GTE will provide post-dial delay at no greater than that provided by GTE for its end user customers. AT&T shall pay GTE's costs, if any, pursuant to the pricing standards of Section 252(d) of the Act, and in such amounts or levels as determined by the Commission for implementation of such routing.

- 4.2.1.29. If AT&T requests the termination of Local Switching, GTE shall promptly remove the class of service assignment from the line.
- 4.2.1.30. If an AT&T Customer subscribes to AT&T provided voice mail and messaging services, GTE shall redirect incoming calls to the AT&T system based upon presubscribed service arrangements (e.g., busy, don't answer, number of rings). GTE shall also provide to AT&T for purposes of AT&T providing voice mail to AT&T Local Service Customers, interfaces applicable to the provision of voice mail services that are Currently Available in GTE's network. Nothing in this section shall limit or change the obligations or rights of either Party under Section 26.7 of Part I of this Agreement (Local Service Resale).
- 4.2.1.31. Local Switching shall be offered in accordance with the technical references listed in Appendix A to this Attachment 2, under paragraph 3 thereof.
- 4.2.2. Interface References (subject to Section 23.19 of the General Terms and Conditions of this Agreement):
 - 4.2.2.1. GTE shall, subject to Section 23.19 of the General Terms and Conditions of this Agreement, provide the following interfaces (i.e., ports) to loops:
 - 4.2.2.2. Standard Tip/Ring interface including loopstart or groundstart, on-hook signaling (e.g., for calling number, calling name and message waiting lamp);
 - 4.2.2.3. Coin phone signaling;
 - 4.2.2.4. Basic Rate Interface ISDN;

- 4.2.2.5. Two-wire analog interface to PBX;
- 4.2.2.6. Four-wire analog interface to PBX;
- 4.2.2.7. Four-wire DS1 interface to PBX or customer provided equipment (e.g. computers and voice response systems);
- 4.2.2.8. Primary Rate ISDN to PBX;
- 4.2.2.9. Switched Fractional DS1 with capabilities to configure Nx64 channels (where N = 1 to 24); and
- 4.2.2.10. GTE shall, where Currently Available, provide access to the following:
- 4.2.2.11. SS7 Signaling Network or Multi-Frequency trunking if requested by AT&T;
- 4.2.2.12. Interface to AT&T operator services systems or Operator Services through appropriate trunk interconnections for the system; and
- 4.2.2.13. Interface to AT&T directory assistance services through the AT&T switched network or to Directory Services through the appropriate trunk interconnections for the system; and 950 access or other AT&T required access to interexchange carriers as requested through appropriate trunk interfaces.
- 4.2.2.14. Interfaces to Loops provided under this Agreement shall meet or exceed the applicable interface references set forth in the technical references listed in Appendix A to this Attachment 2, under paragraph 4 thereof.

4.3. **Integrated Services Digital Network (ISDN)**

Integrated Services Digital Network (ISDN) is defined in two variations. The first variation is Basic Rate ISDN (BRI). BRI consists of 2 Bearer (B) Channels and one Data (D) Channel. The second variation is Primary Rate ISDN (PRI). PRI consists of 23 B Channels and one D Channel. Both BRI and PRI B Channels may be used for voice, Circuit Switched Data (CSD) or Packet Switched Data (PSD). The BRI D Channel may be used for call related signaling, non-call related signaling or packet switched data. The PRI D Channel may be used for call related signaling.

- 4.3.1. Technical References - ISDN (subject to Section 23.19 of the General Terms and Conditions of this Agreement):

- 4.3.1.1. Where available, GTE shall offer Data Switching providing ISDN that:
- 4.3.1.2. Provides integrated packet handling capabilities;
- 4.3.1.3. Allows for full 2B+D Channel functionality for BRI; and.
- 4.3.1.4. Allows for full 23B+D Channel functionality for PRI.
- 4.3.1.5. In the case of Each B Channel, allows for voice, 64Kbs CSD, and PSD of 128 logical channels at minimum speeds of 19Kbs throughput of each logical channel up to the total capacity of the B Channel.
- 4.3.1.6. In the case of Each B Channel, provides capabilities for alternate voice and data on a per call basis.
- 4.3.1.7. In the case of the BRI D Channel, allows for call associated signaling, non-call associated signaling and PSD of 16 logical channels at minimum speeds of 9.6 Kbs throughput of each logical channel up to the total capacity of the D channel.
- 4.3.1.8. In the case of the PRI D Channel, allows for call associated signaling.
- 4.3.2. Interface References - ISDN (subject to Section 23.19 of the General Terms and Conditions of this Agreement):
 - 4.3.2.1. GTE shall provide the BRI U interface using 2 wire copper loops.
 - 4.3.2.2. GTE shall provide the BRI interface using Digital Subscriber Loops.
 - 4.3.2.3. GTE shall offer PSD interfaces.
 - 4.3.2.4. GTE shall offer PSD trunk interfaces operating at 56Kbs.
 - 4.3.2.5. Interfaces to Loops for ISDN requirements provided under this Agreement shall meet or exceed the applicable interface references set forth in the technical references listed in Appendix A to this Attachment 2, under paragraph 5 thereof.

5. **Operator Service**

5.1. [Intentionally Deleted]

5.1.1. **Definition.**

Operator Service provides where Currently Available: (1) operator handling for call completion (for example, collect, third number billing, and manual credit card calls), (2) operator or automated assistance for billing after the customer has dialed the called number; and (3) special services including Busy Line Verification and Emergency Line Interrupt (ELI), Emergency Agency Call, Operator-assisted Directory Assistance, and Rate Quotes.

5.1.2. References (subject to Section 23.19 of the General Terms and Conditions of this Agreement):

5.1.2.1. Operator Services for calls which are routed from the local switch shall include but not be limited to the following, where Currently Available:

5.1.2.2. Completion of 0+ and 0- dialed local calls.

5.1.2.3. Completion of 0+ and 0- intraLATA toll calls.

5.1.2.4. Completion of calls that are billed to a GTE calling card and that use the same types of billing that are available to GTE customers. The Parties shall agree on the acceptable types of special billing.

5.1.2.5. Completion of person-to-person calls.

5.1.2.6. Completion of collect calls.

5.1.2.7. Provision of the capability for callers to bill to a third party and complete such calls.

5.1.2.8. Completion of station-to-station calls.

5.1.2.9. Processing emergency calls.

5.1.2.10. Processing Busy Line Verify and Emergency Line Interrupt requests.

5.1.2.11. Processing emergency call trace.

- 5.1.2.12. Processing of operator-assisted directory assistance calls in the same manner as GTE provides such service for GTE customers.
- 5.1.2.13. GTE shall provide rate quotes and process time-and-charges requests on 0- calls, and shall provide AT&T's rates, when the capability to provide rates other than GTE's is Currently Available.
- 5.1.2.14. Routing of 0- traffic directly to a "live" operator team.
- 5.1.2.15. Operator Services provided by GTE to AT&T local service customers under this Agreement will be customized exclusively for AT&T, where technically feasible, at rates specified in, or as to be determined pursuant to, Attachment 14.
- 5.1.2.16. Provision of caller assistance for the handicapped at parity with what is provided under GTE's tariff.
- 5.1.2.17. [Intentionally deleted.]
- 5.1.2.18. [Intentionally deleted.]
- 5.1.2.19. Provision of notification of the length of call.
- 5.1.2.20. [Intentionally deleted.]
- 5.1.2.21. GTE shall exercise at least the same level of fraud control in providing Operator Service to AT&T that GTE provides for its own operator service.
- 5.1.2.22. Billed Number Screening when handling Collect, Person-to-Person, and Billed-to-Third-Party calls.
- 5.1.2.23. [Intentionally Deleted]
- 5.1.2.24. Direction of customer inquiries to a single, AT&T-designated customer service center.
- 5.1.2.25. [Intentionally deleted.]
- 5.1.2.26. GTE will offer AT&T a level of Operator Services which is at parity with what it provides itself. To the extent that the level of service GTE provides to its own customers exceeds any criterion, requirement or guideline set by the applicable state regulatory commission, GTE shall offer the same level of service to AT&T.

5.1.2.27. GTE will make all of its automation and other new technology related to the provision of Operator Services available to AT&T as soon as the benefit of such automation and other technology is available to GTE's end-users.

5.2. **Interface References** (subject to Section 23.19 of the General Terms and Conditions of this Agreement):

With respect to Operator Services for calls that originate on local switching capability provided by or on behalf of AT&T, the interface requirements shall conform to the then current established system interface specifications for the platform used to provide Operator Service and the interface shall conform to industry standards.

6. **Directory Assistance Service**

6.1. **Definition:**

Directory Assistance Service is a service that provides telephone number information to local end users that GTE serves on behalf of AT&T who dial 411, 1411 or 555-1212 to obtain directory assistance for local numbers within their NPA.

6.1.1. [Intentionally deleted.]

6.2. **Requirements:**

6.2.1. GTE shall offer Directory Assistance Service which allows AT&T Customers to obtain the same quantity of listings provided to similarly situated GTE customers.

6.2.2. Directory Assistance Service provided by GTE to AT&T local service customers under this Agreement will be customized exclusively for AT&T, where technically feasible, at rates specified in, or as to be determined pursuant to, Attachment 14.

6.2.3. GTE Directory Assistance Service will provide optional call completion service to AT&T Customers in areas where call completion denial is Currently Available; Call completion services shall be provided at parity with that which GTE provides to its own end users.

6.2.4. GTE shall provide data regarding billable events.

6.2.5. [Intentionally Deleted]

- 6.2.6. GTE shall ensure that any Directory Assistance information that is provided by ARU shall be repeated in the same manner as it is announced for GTE's end-users;
- 6.2.7. GTE Directory Assistance will provide emergency listings and related services to AT&T Customers at service levels equivalent to those provided to GTE Customers;
- 6.2.8. GTE Directory Assistance Services will include a service which intercepts calls placed to an AT&T Customer whose number has been disconnected or changed. GTE shall provide a recorded announcement to (i) notify a calling party that the end user customer has transferred to a new telephone number of AT&T and (ii) provide such calling party with details concerning the new telephone number to be dialed to reach the customer. GTE shall provide such announcement for the same length of time that GTE provides intercept or referral information for its customers that have changed telephone numbers.
- 6.2.9. [Intentionally deleted.]
- 6.2.10. Directory Assistance Service Updates
- 6.2.10.1. GTE shall update the GTE DA database with AT&T customer listing changes daily. These changes include:
- 6.2.10.2. New customer connections;
- 6.2.10.3. Customer disconnections; and
- 6.2.10.4. Customer changes, including but not limited to name, address and listing status.
- 6.2.10.5. These updates shall also be provided for non-listed and non-published numbers for use in emergencies.

7. Common Transport

7.1. **Definition:**

Common (i.e. shared) transport is a transmission facility shared by more than one carrier, including GTE, between end office switches, between end office switches and tandem switches, and between tandem switches, in GTE's network.

Common transport shall be provided in conjunction with, but priced

separately from, Local Switching and/or Tandem Switching. GTE shall not be required to provide transport other than Dedicated transport between any GTE switch and an AT&T interconnection point or between any GTE serving wire center (as that term is used in Para. 29 of the Third Order on Reconsideration, CC Docket No. 96-98) serving an AT&T interconnection point and any GTE switch.

- 7.2. **Technical References** (subject to Section 23.19 of the General Terms and Conditions of this Agreement):
 - 7.2.1. [Intentionally deleted.]
 - 7.2.2. Common Transport provided on DS1 or VT1.5 circuits at the DS0 rate, shall, at a minimum, subject to Section 23.19 of the General Terms and Conditions of this Agreement, meet the performance, availability, jitter, and delay references specified for Central Office to Central Office "CO to CO" connections in the technical reference in Appendix A to this Attachment 2, under paragraph 6 thereof.
 - 7.2.3. Common Transport provided on DS3 circuits, STS-1 circuits, and higher transmission bit rate circuits, Common Transport shall, at a minimum, subject to Section 23.19 of the General Terms and Conditions of this Agreement, meet the performance, availability, jitter, and delay references specified for Central Office to Central Office "CO to CO" connections in the technical reference set forth in Appendix A to this Attachment 2, under paragraph 6 thereof.
 - 7.2.4. GTE shall be responsible for the engineering, provisioning, and maintenance of the underlying equipment and facilities that are used to provide Common Transport.
 - 7.2.5. Common Transport shall, subject to Section 23.19 of the General Terms and Conditions of this Agreement, meet all of the technical references in Appendix A to this Attachment 2, under paragraph 6 thereof (as applicable for the transport technology being used).

8. **Dedicated Transport**

8.1. **Definition:**

Dedicated Transport is an interoffice transmission path between AT&T designated locations. Such locations may include GTE central offices or other equipment locations, AT&T network components, or other carrier network components.

- 8.1.1. GTE shall offer Dedicated Transport in each of the following ways:

- 8.1.1.1. As capacity on a shared circuit.
- 8.1.1.2. As a circuit (e.g., DS1, DS3, STS-1) dedicated to AT&T.
- 8.1.1.3. As a system (i.e., the equipment and facilities used to provide Dedicated Transport such as SONET ring) dedicated to AT&T. Prices and availability of systems will be provided by GTE using the bona fide request process set forth in Attachment 12 to this Agreement.
- 8.1.2. When Dedicated Transport is provided as a circuit or as capacity on a shared circuit, it shall include (as appropriate):
 - 8.1.2.1. Multiplexing functionality;
 - 8.1.2.2. [Intentionally Deleted]
 - 8.1.2.3. [Intentionally Deleted]
- 8.1.3. To the extent Dedicated Transport is provided pursuant to this Agreement as a system, it shall include: Transmission equipment such as multiplexers, line terminating equipment, amplifiers, regenerators; and inter-office transmission facilities such as optical fiber, copper twisted pair, and coaxial cable. To the extent Dedicated Transport is provided as a system, the Parties shall work together to design that system (including but not limited to facility routing and termination points and facility routing over existing transport facilities between GTE and a second carrier to carry traffic designated for that carrier);
 - 8.1.3.1. [Intentionally deleted.]
 - 8.1.3.2. [Intentionally deleted.]
 - 8.1.3.3. Redundant equipment and facilities necessary to support protection and restoration; and,
 - 8.1.3.4. Dedicated Transport includes the Digital Cross-Connect System (DCS) functionality as an option. DCS is described below in Section 8.4.
- 8.2. **Technical References**

This Section sets forth technical references, subject to Section 23.19 of the General Terms and Conditions of this Agreement, for all Dedicated Transport.

- 8.2.1. When GTE provides Dedicated Transport as a circuit or a system, the entire designated transmission circuit or system (e.g., DS1, DS3, STS-1) shall be dedicated to AT&T designated traffic.
- 8.2.2. GTE shall offer Dedicated Transport in all then Currently Available technologies including, but not limited to, DS1 and DS3 transport systems, SONET (or SDH) Bi-directional Line Switched Rings, SONET (or SDH) Unidirectional Path Switched Rings, and SONET (or SDH) point-to-point transport systems (including linear add-drop systems), at all available transmission bit rates.
- 8.2.3. For DS1 or VT1.5 circuits, Dedicated Transport shall, at a minimum, meet the performance, availability, jitter, and delay references specified for Customer Interface to Central Office "CI to CO" connections in the technical references listed in Appendix A to this Attachment 2, at paragraph 2.6 thereof.
- 8.2.4. For DS3 circuits, STS-1 circuits, and higher rate circuits, Dedicated Transport shall, at a minimum, meet the performance, availability, jitter, and delay references specified for Customer Interface to Central Office "CI to CO" connections in the technical reference listed in Appendix A to this Attachment 2, at paragraph 2.13 thereof.
- 8.2.5. When requested by AT&T, Dedicated Transport shall provide physical diversity. Physical diversity means that two circuits are provisioned in such a way that no single failure of facilities or equipment will cause a failure on both circuits.
- 8.2.6. When physical diversity is requested by AT&T, GTE shall provide the maximum available physical separation between intra-office and inter-office transmission paths (unless otherwise agreed by AT&T).
- 8.2.7. Upon AT&T's request, GTE shall provide Real Time and continuous remote access to performance monitoring and alarm data affecting, or potentially affecting, AT&T's traffic.
- 8.2.8. GTE shall offer the following interface transmission rates for Dedicated Transport:
- 8.2.8.1. DS1 (Extended SuperFrame - ESF, D4, and unframed applications shall be provided);
- 8.2.8.2. DS3 (C-bit Parity, M13, and unframed applications shall be provided);

- 8.2.8.3. SONET standard interface rates in accordance with ANSI T1.105 and ANSI T1.105.07 and physical interfaces per ANSI T1.106.06 (including referenced interfaces). In particular, VT1.5 based STS-1s will be the interface at an AT&T service node.
- 8.2.8.4. SDH Standard interface rates in accordance with International Telecommunications Union (ITU) Recommendation G.707 and Plesiochronous Digital Hierarchy (PDH) rates per ITU Recommendation G.704.
- 8.2.9. GTE shall provide cross-office wiring up to a suitable Point of Termination (POT) between Dedicated Transport and AT&T designated equipment. GTE shall provide the following equipment for the physical POT:
- 8.2.9.1. DSX1 for DS1s or VT1.5s;
- 8.2.9.2. DSX3 for DS3s or STS-1s; and
- 8.2.9.3. LGX for optical signals (e.g., OC-3 and OC-12)
- 8.2.10. [Intentionally deleted]
- 8.2.11. [Intentionally deleted]
- 8.2.12. Upon AT&T's request, GTE shall provide AT&T with electronic provisioning control of Dedicated Transport purchased by AT&T and connected to a Digital Cross Connect System (DCS), if the DCS is capable of partitioned access and control.
- 8.2.13. [Intentionally deleted]
- 8.2.14. At a minimum, Dedicated Transport shall meet each of the references set forth in Section 7.2 and in the technical references listed in Appendix A to this Attachment 2, under paragraph 7 thereof.
- 8.3. Technical References for Dedicated Transport Using SONET technology.
- This Section sets forth additional technical references, subject to Section 23.19 of the General Terms and Conditions of this Agreement, for Dedicated Transport using SONET technology including rings, point-to-point systems, and linear add-drop systems.

- 8.3.1. All SONET Dedicated Transport provided as a system shall:
 - 8.3.1.1. Be synchronized from both a primary and secondary Stratum 1 level timing source. Additional detail on synchronization references are given in Section 13.4.
 - 8.3.1.2. Provide SONET standard interfaces which properly interwork with SONET standard equipment from other vendors. This includes, but is not limited to, SONET standard Section, Line, and Path performance monitoring, maintenance signals, alarms, and data channels.
 - 8.3.1.3. Provide Data Communications Channel (DCC) or equivalent connectivity through the SONET transport system. Dedicated Transport provided over a SONET transport system shall be capable of routing DCC messages between AT&T SONET network components connected to the Dedicated Transport. For example, if AT&T leases a SONET ring from GTE, that ring shall support DCC message routing between AT&T SONET network components connected to the ring.
 - 8.3.1.4. Support the following performance references for each circuit (STS-1, DS1, DS3, etc.):
 - 8.3.1.4.1. No more than 10 Errored Seconds Per Day (Errored Seconds are defined in the technical reference at Appendix A to this Attachment 2 at paragraph 7.5); and
 - 8.3.1.4.2. No more than 1 Severely Errored Second Per Day (Severely Errored Seconds are defined in the technical references set forth in Appendix A to this Attachment 2, at paragraph 7.5).
- 8.3.2. All SONET rings shall, subject to Section 23.19 of the General Terms and Conditions of this Agreement:
 - 8.3.2.1. Be provisioned on physically diverse fiber optic cables (including separate building entrances where available and diversely routed intra-office wiring). "Diversely routed" shall be interpreted as the maximum feasible and available physical separation between transmission paths, unless otherwise agreed by AT&T.
 - 8.3.2.2. Support dual ring interworking per SONET Standards.
 - 8.3.2.3. Provide the necessary redundancy in optics, electronics, and transmission paths (including intra-office wiring) such that no single failure will cause a service interruption.

- 8.3.2.4. Provide the ability to disable ring protection switching at AT&T's direction (selective protection lock-out). This reference applies to line switched rings only.
- 8.3.2.5. Provide the ability to use the protection channels to carry traffic (extra traffic). This reference applies to line switched rings only.
- 8.3.2.6. Provide 50 millisecond restoration unless a ring protection delay is set to accommodate dual ring interworking schemes.
- 8.3.2.7. Have settable ring protection switching thresholds that shall be set in accordance with AT&T's specifications.
- 8.3.2.8. Provide revertive protection switching with a settable wait to restore delay with a default setting of 5 minutes. This reference applies to line switched rings only.
- 8.3.2.9. Provide non-revertive protection switching. This reference applies to path switched rings only.
- 8.3.2.10. Be based upon the following availability references, where availability is defined in the technical reference listed in Appendix A to this Attachment 2, at paragraph 7.5 thereof.
 - 8.3.2.10.1. No more than 0.25 minutes of unavailability month; and
 - 8.3.2.10.2. No more than 0.5 minutes of unavailability per year.

8.4. **Digital Cross-Connect System (DCS)**

8.4.1. Definition:

When AT&T requests a functionality that GTE is required to provide to AT&T pursuant to this Agreement, GTE will provision this functionality at a level of quality equal to that which it provides to itself.

- 8.4.1.1. DCS is a function which provides automated cross connection of Digital Signal level 0 (DS0) or higher transmission bit rate digital channels within physical interface facilities. Types of DCSs include but are not limited to DCS 1/0s, DCS 3/1s, and DCS 3/3s, where the nomenclature 1/0 denotes interfaces typically at the DS1 rate or greater with cross-connection typically at the DS0 rate. This same nomenclature, at the appropriate rate substitution, extends to the other types of DCSs specifically cited as 3/1 and 3/3. Types of

DCSs that cross-connect Synchronous Transport Signal level 1 (STS-1s) or other Synchronous Optical Network (SONET) signals (e.g., STS-3) are also DCSs, although not denoted by this same type of nomenclature. DCS may provide the functionality of more than one of the aforementioned DCS types (e.g., DCS 3/3/1 which combines functionality of DCS 3/3 and DCS 3/1). For such DCSs, the guidelines will be, at least, the aggregation of guidelines on the "component" DCSs.

- 8.4.1.2. In locations where automated cross connection capability does not exist, DCS will be defined as the combination of the functionality provided by a Digital Signal Cross-Connect (DSX) or Light Guide Cross-Connect (LGX) patch panels and D4 channel banks or other DS0 and above multiplexing equipment used to provide the function of a manual cross connection.
- 8.4.1.3. Interconnection between a DSX or LGX, to a switch, another cross-connect, or other service platform device, is included as part of DCS.
- 8.5. DCS Technical References. GTE shall provide DCS at the same level of quality as GTE provides in its own network. For example, DCS shall, where Currently Available:
 - 8.5.1. Provide completed end-to-end cross connection of the channels designated by AT&T.
 - 8.5.2. Perform facility grooming, multipoint bridging, one-way broadcast, two-way broadcast, and facility test functions.
 - 8.5.3. Provide multiplexing, format conversion, signaling conversion, or other functions.
 - 8.5.4. [Intentionally deleted.]
 - 8.5.5. GTE shall continue to administer and maintain DCS, including updates to the control software to current available releases.
 - 8.5.6. GTE shall, to the extent Currently Available, provide various types of Digital Cross-Connect Systems including:
 - 8.5.6.1. DS0 cross-connects (typically termed DCS 1/0);
 - 8.5.6.2. DS1/VT1.5 (Virtual Tributaries at the 1.5Mbps rate) cross-connects (typically termed DCS 3/1);

- 8.5.6.3. DS3 cross-connects (typically termed DCS 3/3);
- 8.5.6.4. STS-1 cross-connects; and
- 8.5.6.5. Other Currently Available cross-connects designated by the Parties.
- 8.5.7. To the extent GTE provides such capability to itself, GTE shall provide in accordance with Section 8.2.12 of this Attachment 2, immediate and continuous configuration and reconfiguration of the channels between the physical interfaces.
- 8.5.8. To the extent GTE provide such capability to itself, GTE shall provide scheduled configuration and reconfiguration of the channels between the physical interfaces (i.e., GTE shall establish the processes to implement cross connects on the schedule designated by the Parties).
- 8.5.9. To the extent GTE provides such capability to itself, DCS shall continuously monitor protected circuit packs and redundant common equipment.
- 8.5.10. To the extent GTE provides such capability to itself, DCS shall automatically switch to a protection circuit pack on detection of a failure or degradation of normal operation.
- 8.5.11. To the extent GTE provides such capability to itself, the underlying equipment used to provide DCS shall be equipped with a redundant power supply or a battery back-up.
- 8.5.12. To the extent GTE provides such capability to itself, GTE shall provide to AT&T spare facilities and equipment if ordered by AT&T, at AT&T's expense to the extent such costs are not included in the cost of the unbundled network element, necessary for provisioning repairs, and to meet AT&T's Direct Measures of Quality (DMOQs) as specified in the Provisioning and Maintenance sections.
- 8.5.13. To the extent GTE provides such capability to itself, GTE shall provide to AT&T upon AT&T's request, and at AT&T's expense to the extent such costs are not included in the cost of the unbundled network element, Real Time performance monitoring and alarm data on the signals and the components of the underlying equipment used to provide DCS that actually impact or might impact AT&T's services.

- 8.5.14. At AT&T's option and to the extent GTE provides such services to itself and is capable of providing such service to AT&T on a partitioned access and control basis, GTE shall provide AT&T with Real Time ability to initiate tests on integrated equipment used to test the signals and the underlying equipment used to provide DCS, as well as other integrated functionality for routine testing and fault isolation.
- 8.5.15. Where Currently Available, DCS shall provide SONET to asynchronous gateway functionality (e.g., STS-1 to DS1 or STS-1 to DS3).
- 8.5.16. Where Currently Available, DCS shall perform optical to electrical conversion where the underlying equipment used to provide DCS contains optical interfaces or terminations (e.g., Optical Carrier level 3, i.e., OC-3 interfaces on a DCS 3/1).
- 8.5.17. Where Currently Available, DCS shall have SONET ring terminal functionality where the underlying equipment used to provide DCS acts as a terminal on a SONET ring.

8.5.18. Where Currently Available, DCS shall provide multipoint bridging of multiple channels to other DCSs. AT&T may designate multipoint bridging to be one-way broadcast from a single master to multiple tributaries, or two-way broadcast between a single master and multiple tributaries. [Intentionally deleted]

[Combinations]

- 8.5.19. Where Currently Available, DCS shall multiplex lower speed channels onto a higher speed interface and demultiplex higher speed channels onto lower speed interfaces as designated by AT&T.
- 8.6. **DCS Interface References (subject to Section 23.19 of the General Terms and Conditions of this Agreement):**
- 8.6.1. GTE shall provide physical interfaces on DS0, DS1, and VT1.5 channel cross-connect devices at the DS1 rate or higher. In all such cases, these interfaces shall be in compliance with applicable Bellcore, ANSI, ITU, and AT&T standards.
- 8.6.2. GTE shall provide physical interfaces on DS3 channel cross-connect devices at the DS3 rate or higher. In all such cases, these

interfaces shall be in compliance with applicable Bellcore, ANSI, ITU, and AT&T standards.

8.6.3. GTE shall provide physical interfaces on STS-1 cross-connect devices at the OC-3 rate or higher. In all such cases, these interfaces shall be in compliance with applicable Bellcore, ANSI, ITU , and AT&T standards.

8.6.4. Interfaces on all other cross-connect devices shall be in compliance with applicable Bellcore, ANSI, ITU , and AT&T standards.

8.6.5. DCS shall, at a minimum, meet all the references set forth in the technical references listed in Appendix A to this Attachment 12, under paragraph 8 thereof.

9. **Signaling Link Transport**

9.1. **Definition:**

Signaling Link Transport is a set of two or four dedicated 56 Kbps. transmission paths between AT&T-designated Signaling Points of Interconnection (SPOI) that provides appropriate physical diversity.

9.2. **Technical Guidelines (subject to Section 23.19 of the General Terms and Conditions of this Agreement):**

Signaling Link Transport shall consist of full duplex mode 56 kbps transmission paths. GTE shall provide Interfaces at the same level of quality as GTE provides in its own network:

9.3. Of the various options available, Signaling Link Transport shall perform in the following two ways:

9.3.1. As an "A-link" which is a connection between a switch and a home Signaling Transfer Point Switch (STPS) pair; and

9.3.2. As a "D-link" which is a connection between two STPS pairs in different company networks (e.g., between two STPS pairs for two Competitive Local Exchange Carriers (CLECs)).

9.4. Signaling Link Transport shall consist of two or more signaling link layers as follows:

9.4.1. An A-link layer shall consist of two links.

- 9.4.2. A D-link layer shall consist of four links.
- 9.4.3. A signaling link layer provided to AT&T pursuant to this Agreement shall perform at the same level of quality and performance levels as a similar signaling link layer in GTE's network. Examples of objectives may be:
- 9.4.3.1. There shall be no more than two minutes down time per year for an A-link layer; and
- 9.4.3.2. There shall be negligible (less than 2 seconds) down time per year for a D-link layer.
- 9.4.4. Where Currently Available, a signaling link layer shall satisfy interoffice and intraoffice diversity of facilities and equipment. Example objectives are:
- 9.4.5. No single failure of facilities or equipment causes the failure of both links in an A-link layer; and
- 9.4.6. No two concurrent failures of facilities or equipment shall cause the failure of all four links in a D-link layer.
- 9.5. **Interface References** GTE shall provide Interfaces at the same level of quality as GTE provides for Interfaces Currently Available in its own network. Subject to Section 23.19 of the General Terms and Conditions of this Agreement, such interfaces shall, for example, be based on but not limited to the following references:
- 9.5.1. There shall be a dedicated DS1 (1.544 Mbps) interface at the AT&T-designated SPOIs. Each 56 kbps transmission path shall appear as a DS0 channel within the DS1 interface.
10. **Signaling Transfer Points (STPs)**
- 10.1. **Definition:** Signaling Transfer Points is a signaling network function that includes all of the capabilities provided by the signaling transfer point switches (STPs) and their associated signaling links which enable the exchange of SS7 messages among and between switching elements, database elements and signaling transfer point switches.
- 10.2. **Technical References** GTE shall provide access to STPs at the same level of quality as GTE provides access to Currently

Available STPs in its own network, subject to Section 23.19 of the General Terms and Conditions of this Agreement. For example:

- 10.2.1. STPs shall provide access to all other Network Elements connected to the GTE SS7 network. These include:
 - 10.2.1.1. GTE Local Switching or Tandem Switching;
 - 10.2.1.2. GTE Service Control Points/DataBases;
 - 10.2.1.3. Third-party local or tandem switching systems; and
 - 10.2.1.4. Third-party-provided STPs.
- 10.2.2. The connectivity provided by STPs shall fully support the functions of all other Network Elements connected to those STPs on the GTE SS7 network. This explicitly includes the use of the GTE SS7 network to convey messages which neither originate nor terminate at a signaling end point directly connected to the GTE SS7 network (i.e., transient messages). When the GTE SS7 network is used to convey transient messages, there shall be no alteration of the Integrated Services Digital Network User Part (ISDNUP) or Transaction Capabilities Application Part (TCAP) user data that constitutes the content of the message.
- 10.2.3. If a GTE tandem switch routes calling traffic, based on dialed or translated digits, on SS7 trunks between an AT&T local switch and third party local switch, the GTE SS7 network shall convey the TCAP messages that are necessary to provide Call Management features (Automatic Callback, Automatic Recall, and Screening List Editing) between the AT&T local STPSs and the STPSs that provide connectivity with the third party local switch, even if the third party local switch is not directly connected to the GTE STPSs provided the third party's STPs and the AT&T local STPs are both connected to the GTE STPs to which the AT&T local switch is connected.
- 10.2.4. STPs shall provide all functions of the SCCP necessary for Class 0 (basic connectionless) service. In cases where the destination signaling point is a GTE local or tandem switching system or data base, or is an AT&T or third party local or tandem switching system directly connected to the GTE SS7 network, STPs shall perform final GTT of messages to the destination and SCCP Subsystem Management of the destination. In all other cases, STPs shall perform intermediate GTT of messages to a gateway pair of STPSs

in an SS7 network connected with the GTE SS7 network, and shall not perform SCCP Subsystem Management of the destination.

- 10.2.5. When such capability is deployed in the GTE network, STPs shall provide all functions of the OMAP commonly provided by STPs, as specified in the reference set forth in Appendix A to this Attachment 2, at paragraph 9.5. This includes:
 - 10.2.5.1. MTP Routing Verification Test (MRVT); and,
 - 10.2.5.2. SCCP Routing Verification Test (SRVT).
- 10.2.6. This Section 10.2.6 applies when such capabilities are deployed in the GTE network. In cases where the destination signaling point is a GTE local or tandem switching system or DB, or is an AT&T or third party local or tandem switching system directly connected to the GTE SS7 network, STPs shall perform MRVT and SRVT to the destination signaling point. In all other cases, STPs shall perform MRVT and SRVT to a gateway pair of STPSs in an SS7 network connected with the GTE SS7 network. This reference shall be superseded by the specifications for Internetwork MRVT and SRVT if and when these become approved ANSI standards and available capabilities of GTE STPs.
- 10.2.7. AT&T and GTE agree to participate in the industry IN Forum "Interconnection and Access Group" project to address interconnection requirements for multiple third party AIN SCP access to GTE's switch triggers. AT&T and GTE recognize that actual commencement of tests under this project will be determined by all participants in the project.
- 10.3. **Interface References** GTE shall provide Interfaces at the same level of quality as GTE provides for Interfaces Currently Available in its own network, subject to Section 23.19 of the General Terms and Conditions of this Agreement. For example:
 - 10.3.1. GTE shall provide the following STPs options to connect AT&T or AT&T-designated local switching systems or STPSs to the GTE SS7 network:
 - 10.3.1.1. An A-link interface from AT&T local switching systems; and,
 - 10.3.1.2. A D-link interface from AT&T local STPSs.

10.3.2. Subject to Section 23.19 of the General Terms and Conditions of this Agreement, each type of interface shall be provided by one or more sets (layers) of signaling links, as follows:

10.3.2.1. An A-link layer shall consist of two links.

10.3.2.2. A D-link layer shall consist of four links.

10.3.3. [See Section 13.5.3.3 of this Attachment.]

10.3.4. [See Section 13.5.3.4 of this Attachment.]

10.4. **Message Screening**

10.4.1. GTE shall set message screening parameters so as to accept messages from AT&T local or tandem switching systems destined to any signaling point in the GTE SS7 network with which the AT&T switching system is connected and has a legitimate signaling relation.

10.4.2. GTE shall set message screening parameters so as to accept messages from AT&T local or tandem switching systems destined to any signaling point or network interconnected within the GTE SS7 network with which the AT&T switching system is connected and has a legitimate signaling relation.

10.4.3. GTE shall set message screening parameters so as to accept messages destined to an AT&T local or tandem switching system from any signaling point or network interconnected within the GTE SS7 network with which the AT&T switching system is connected and has a legitimate signaling relation.

10.4.4. GTE shall set message screening parameters so as to accept and send messages destined to an AT&T SCP from any signaling point or network interconnected to those STPs within the GTE SS7 network with which the AT&T SCP is connected and has a legitimate signaling relation.

10.5. STPs shall meet or exceed the references for STPs set forth in the technical references listed in Appendix A to this Attachment 2, under paragraph 9 thereof.

11. **Service Control Points/Databases**

11.1. **Definition:**

Databases are the Network Elements that provide the functionality

for storage of, access to, and manipulation of information required to offer a particular service and/or capability.

- 11.1.1. A Service Control Point (SCP) is a specific type of Database Network Element functionality deployed in a Signaling System 7 (SS7) network that executes service application logic in response to SS7 queries sent to it by a switching system also connected to the SS7 network. SCPs also provide operational interfaces to allow for provisioning, administration and maintenance of subscriber data and service application data. (e.g., an 800 database stores customer record data that provides information necessary to route 800 calls).
- 11.2. **Technical References for SCPs/Databases** (subject to Section 23.19 of the General Terms and Conditions of this Agreement):
References for SCPs/Databases within this section address storage of information, access to information (e.g. signaling protocols, response times), and administration of information (e.g., provisioning, administration, and maintenance). All SCPs/Databases shall be provided to AT&T in accordance with the following references, except where such a reference is superseded by specific references set forth in Sections 11.3 to 11.7.
- 11.2.1. GTE shall make available physical interconnection to SCPs through the SS7 network and protocols, as specified in Section 10 of this Attachment, with TCAP as the application layer protocol.
- 11.2.2. Except for GTE's directory assistance databases, GTE shall provide physical interconnection to databases via industry standard interfaces and protocols. GTE will provide AT&T with copies of its directory assistance databases on magnetic tape. GTE will also provide to AT&T daily updates to its directory assistance databases on magnetic tape. AT&T and GTE shall agree on the type of magnetic tape, the format of the data on the tapes, the locations for delivery of the tapes, and all other implementation issues that the parties need to be resolved within ten days of the Effective Date of this Agreement. If the parties fail to reach agreement pursuant to this Section, the parties will submit the disputed issues to the alternative dispute resolution process as set forth in this Agreement.
- 11.2.3. The reliability of interconnection options shall be consistent with requirements for diversity and survivability as specified in Section 10 of this Attachment (which applies to both SS7 and non-SS7 interfaces).

- 11.2.4. [Intentionally deleted.]
- 11.2.5. GTE shall provide Database provisioning consistent with the provisioning requirements of this Agreement (e.g., data required, edits, acknowledgments, data format and transmission medium and notification of order completion).
- 11.2.6. GTE shall provide Database maintenance consistent with the maintenance requirements as specified in this Agreement.
- 11.2.7. GTE shall provide billing and recording information to track database usage consistent with connectivity billing and recording requirements as specified in this Agreement.
- 11.2.8. GTE shall provide SCPs/Databases in accordance with the physical security requirements specified in this Agreement.
- 11.2.9. GTE shall provide SCPs/Databases in accordance with the logical security requirements specified in this Agreement.
- 11.3. **Line Information Database (LIDB).**
This Subsection defines and sets forth additional references for the Line Information Database.
- 11.3.1. Definition:
The Line Information Database (LIDB) is a transaction-oriented database accessible through Common Channel Signaling (CCS) networks. It contains records associated with customer Line Numbers and Special Billing Numbers (in accordance with the references set forth in the technical reference listed in Appendix A to this Attachment 2, at paragraph 10.5.). LIDB accepts queries from other Network Elements and provides appropriate responses. The query originator need not be the owner of LIDB data. LIDB queries include functions such as screening billed numbers that provides the ability to accept Collect or Third Number Billing calls and validation of Telephone Line Number based non-proprietary calling cards. The interface for the LIDB functionality is the interface between the GTE CCS network and other CCS networks. LIDB also interfaces to administrative systems. The administrative system interface provides Work Centers with an interface to LIDB for functions such as provisioning, auditing of data, access to LIDB measurements and reports.
- 11.3.2. Technical References (subject to Section 23.19 of the General Terms and Conditions of this Agreement):

- 11.3.2.1. Prior to the availability of a long-term solution for Local Number Portability, GTE shall enable AT&T to store in GTE's LIDB any customer Line Number or Special Billing Number record, for which the NPA-NXX or NXX-0/1XX Group is supported by that LIDB.
- 11.3.2.2. Prior to the availability of a long-term solution for Local Number Portability, GTE shall enable AT&T to store in GTE's LIDB any customer Line Number or Special billing Number record, and NPA-NXX and NXX-0/1XX Group Records, belonging to an NPA-NXX or NXX-0/1XX owned by AT&T. The terms and conditions upon which such storage shall be made available to AT&T shall be set forth in a LIDB storage agreement to be entered into between the Parties.
- 11.3.2.3. Subsequent to the availability of a long-term solution for Local Number Portability, GTE shall enable AT&T to store in GTE's LIDB any customer Line Number or Special Billing Number record, regardless of the number's NPA-NXX or NXX-0/1XX. The terms and conditions upon which such storage shall be made available to AT&T shall be set forth in a LIDB storage agreement to be entered into between the Parties.
- 11.3.2.4. GTE shall perform the following LIDB functions for AT&T's customer records in LIDB:
 - 11.3.2.4.1. Billed Number Screening (provides information such as whether the Billed Number may accept Collect or Third Number Billing calls); and
 - 11.3.2.4.2. Calling Card Validation
- 11.3.2.5. GTE shall process AT&T's customer records in LIDB at least at parity with GTE customer records. With respect to other LIDB functions, GTE shall indicate to AT&T what additional functions (if any) are performed by LIDB in their network.
- 11.3.2.6. Within two (2) weeks after a request by AT&T, GTE shall provide AT&T with a list of the customer data items which AT&T would have to provide in order to support each required LIDB function. The list shall indicate which data items are essential to LIDB function, and which are required only to support certain services. For each data item, the list shall show the data formats, the acceptable values of the data item and the meaning of those values.
- 11.3.2.7. [Intentionally deleted.]

- 11.3.2.8. [Intentionally deleted.]
- 11.3.2.9. [Intentionally deleted.]
- 11.3.2.10. GTE shall make changes to NPA-NXX and NXX-0/1XX Group Records, and Line Number and Special Billing Number Records associated with AT&T Customer, as requested by AT&T, within time frames at parity with those time frames in which GTE makes such changes for its own or any other carrier's customers.
- 11.3.2.11. In the event that end user customers change their local service provider, GTE shall maintain customer data (for line numbers, card numbers, and for any other types of data maintained in LIDB excluding GTE-issued line based calling card numbers and associated PINs) so that such customers shall not experience any interruption of service due to the lack of such maintenance of customer data.
- 11.3.2.12. All additions, updates and deletions of AT&T data to the LIDB shall be solely at the direction of AT&T.
- 11.3.2.13. GTE shall provide priority updates to LIDB for AT&T data upon AT&T's request (e.g., to support fraud protection).
- 11.3.2.14. [Intentionally deleted.]
- 11.3.2.15. GTE shall perform backup and recovery of all of AT&T's data in LIDB in the same manner as GTE performs backup and recovery of GTE's data, including sending to LIDB all changes made since the date of the most recent backup copy.
- 11.3.2.16. GTE shall, to the extent GTE can partition LIDB measurements and reports, provide to AT&T access to LIDB measurements and reports at least at parity with the capability GTE has for its own customer.
- 11.3.2.17. To the extent GTE can partition LIDB measurements and reports, GTE shall provide AT&T with LIDB reports of data which are missing or contain errors, as well as any misroute errors to the degree and on the same schedule as GTE provides such reports to itself.
- 11.3.2.18. GTE shall prevent any access to or use of AT&T data in LIDB by GTE personnel or by any other party that does not have a need to know such information in order to provide services pursuant to this Agreement.

- 11.3.2.19. Where technically feasible and Currently Available, GTE shall provide AT&T performance of the LIDB Data Screening function, which allows a LIDB to completely or partially deny specific query originators access to LIDB data owned by specific data owners, (in accordance with the technical reference listed in Appendix A to this Attachment 2, at paragraph 10.5.) for Customer Data that is part of an NPA-NXX or NXX-0/1XX wholly or partially owned by AT&T at least at parity with GTE Customer Data. AT&T will provide GTE the screening information associated with LIDB Data Screening of AT&T data in accordance with this requirement.
- 11.3.2.20. GTE shall accept queries to LIDB associated with AT&T Customer records, and shall return responses in accordance with the references of this Section 11.
- 11.3.2.21. [Intentionally deleted.]
- 11.3.2.22. [Intentionally deleted.]
- 11.3.2.23. [Intentionally deleted.]
- 11.3.2.24. [Intentionally deleted.]
- 11.3.2.24.1. [Intentionally deleted.]
- 11.3.2.24.2. [Intentionally deleted.]
- 11.3.2.24.3. [Intentionally deleted.]
- 11.3.2.24.4. [Intentionally deleted.]
- 11.3.2.24.5. [Intentionally deleted.]
- 11.3.2.24.6. [Intentionally deleted.]
- 11.3.2.24.6.1. [Intentionally deleted.]
- 11.3.2.24.6.2. [Intentionally deleted.]
- 11.3.2.24.6.3. [Intentionally deleted.]
- 11.3.3. **LIDB Interface References** (subject to Section 23.19 of the General Terms and Conditions of this Agreement): GTE shall offer LIDB in accordance with the references of this Subsection.

- 11.3.3.1. The interface to LIDB shall be in accordance with the technical reference listed in Appendix A to this Attachment 2, at paragraph 10.3.
- 11.3.3.2. The CCS interface to LIDB shall be the standard interface listed in Appendix A to this Attachment 2, at paragraph 10.3.
- 11.3.3.3. The LIDB Data Base interpretation of the ANSI-TCAP messages shall comply with the technical reference listed in Appendix A to this Attachment 2, at paragraph 10.4. Global Title Translation shall be maintained in the signaling network in order to support signaling network routing to the LIDB.

11.4. **Toll Free Number Database**

The Toll Free Number Database is a SCP that provides functionality necessary for toll free (e.g., 800 and 888) number services by providing routing information and additional so-called vertical features during call set-up in response to queries from SSPs. GTE shall provide the Toll Free Number Database in accordance with the following:

- 11.4.1. Technical References (subject to Section 23.19 of the General Terms and Conditions of this Agreement):
 - 11.4.1.1. GTE shall make the GTE Toll Free Number Database available for AT&T to query with a toll-free number and originating information.
 - 11.4.1.2. The Toll Free Number Database shall return carrier identification and, where applicable, the queried toll free number, translated numbers and instructions as it would in response to a query from a GTE switch.
- 11.4.2. Signaling Interface References (subject to Section 23.19 of the General Terms and Conditions of this Agreement):

The signaling interface between the AT&T or other local switch and the Toll-Free Number database shall use the TCAP protocol as specified in the technical reference listed in Appendix A to this Attachment 2, at paragraph 10.1, together with the signaling network interface as specified in the technical reference listed in Appendix A to this Attachment 2, at paragraphs 10.2. and 10.6.

- 11.5. **Automatic Location Identification/Data Management System (ALI/DMS)**
- 11.5.1. The ALI/DMS Database contains customer information (including name, address, telephone information, and sometimes special information from the local service provider or customer) used to determine to which Public Safety Answering Point (PSAP) to route the call. The ALI/DMS database is used to provide more routing flexibility for E911 calls than Basic 911.
- 11.6. **Technical References** (subject to Section 23.19 of the General Terms and Conditions of this Agreement): GTE shall provision the Automatic Location Identification/Data Management System (ALI/DMS) and shall provide to AT&T the associated functions and capabilities of that system at the same level of quality as GTE provides to itself.
- 11.6.1. GTE may provide the Emergency Services Data Base in accordance with the following: GTE may offer AT&T a data link to the port connection for the ALI/DMS database or permit AT&T to provide its own data link to the port connection for the ALI/DMS database to AT&T immediately after AT&T inputs information into the ALI/DMS database. Alternatively, AT&T may utilize GTE to enter customer information into the database on a demand basis, and validate customer information on a demand basis.
- 11.6.2. The ALI/DMS database shall where Currently Available, contain the following customer information:
- 11.6.2.1. Name;
- 11.6.2.2. Address;
- 11.6.2.3. Telephone number; and
- 11.6.2.4. Other information as appropriate (e.g., whether a customer is blind or deaf or has another disability).
- 11.6.2.5. When GTE is responsible for administering the ALI/DMS database in its entirety, ported number NXXs entries for the ported numbers should be maintained and updated appropriately.
- 11.6.2.6. When Remote Call Forwarding (RCF) is used to provide number portability to the local customer and a remark or other appropriate field information is available in the database, the shadow or

“forwarded-to” number sent from AT&T to GTE and an indication that the number is ported shall be added to the customer record.

- 11.6.2.7. If GTE is responsible for configuring PSAP features (for cases when the PSAP or GTE supports an ISDN interface) the Parties shall work together to ensure that CLASS Automatic Recall (Call Return) is not used to call back to the ported number.
- 11.6.2.8. [Intentionally deleted.]
- 11.6.3. SCPs/Databases shall meet or exceed the references for SCPs/Databases set forth in the technical references listed in Appendix A to this Attachment 2, under paragraph 10.
- 11.7. Service Creation Environment and Service Management System (SCE/SMS) Advanced Intelligent Network (AIN) Access
 - 11.7.1. Advanced Intelligent Network (AIN) Database. AT&T shall have the right to obtain access to and to use GTE's service applications in the GTE SMS in addition to AT&T's own service applications that AT&T deploys via the GTE SMS to the GTE SCP, as required below. AT&T may use and access such service applications either through AT&T Switch(es) to the GTE AIN SCP via interconnection of the GTE SS7 and AT&T SS7 networks or through its purchase of unbundled elements, including local switching, from GTE. When AT&T obtains access to GTE's service applications using an AT&T switch, this interconnection arrangement shall result in the GTE AIN SCP recognizing the AT&T Switch as at least at parity with GTE's Local Switch in terms of interfaces, performance and capabilities.
 - 11.7.1.1. GTE STPs shall maintain global title translations necessary to direct AIN queries for select global title address and translation type values to and from the AT&T SS7 network, within the global title translation capacity to the STP.
 - 11.7.1.2. Requirements for billing and recording information to track AIN query-response usage shall be consistent with Connectivity Billing and Recording requirements as specified in Attachment 6 (e.g., recorded message format and content, timeliness of feed, data format and transmission medium).
 - 11.7.1.3. GTE shall provide to AT&T all necessary testing resources and staff to perform service certification testing prior to service deployment in accordance with the Cooperative Testing section of this Agreement.

- 11.7.1.4. [Intentionally deleted]
- 11.7.1.5. When AT&T selects SS7 Access, GTE will provide interconnection of its SS7 network per Section 10 of this Attachment 2 with AT&T's SS7 network for exchange of AIN TCAP messages between AT&T's SSP and GTE's AIN SCP.
- 11.7.1.6. STPs shall offer SS7 AIN Access in accordance with the technical references listed in Appendix A to this Attachment 2, under paragraph 11.
- 11.7.2. SCE/SMS AIN Access shall provide AT&T the ability to create service applications in the GTE SCE and deploy those applications via the GTE SMS to the GTE SCP. This interconnection arrangement shall provide AT&T access to the GTE development environment and administrative system in a manner at least at parity with GTE's ability to deliver its own AIN-based services, subject to reasonable security arrangements. SCE/SMS AIN Access is the development of service applications within the GTE Service Creation Environment, and deployment of service applications via the GTE Service Management System. AT&T requests to use the GTE SCE will be subject to request, review and testing procedures to be agreed upon by the Parties. See Figure 2 below.

FIGURE 2

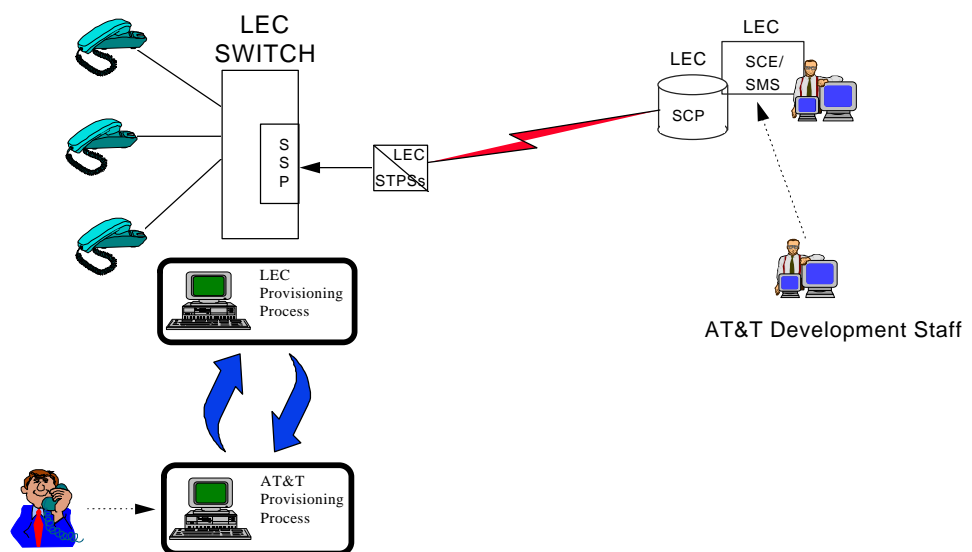

- 11.7.2.1. GTE shall make SCE hardware, software, testing and technical support (e.g., technical contacts, system administrator) resources available to AT&T. Scheduling of SCE resources shall allow AT&T at least equal priority to GTE.
- 11.7.2.2. The GTE SCE/SMS shall allow for multi-user access with proper source code management and other logical security functions as specified in the Security section of this Agreement.
- 11.7.2.3. The GTE SCP shall partition and protect AT&T service logic and data from unauthorized access, execution or other types of compromise.
- 11.7.2.4. GTE shall provide training and documentation for AT&T development staff only in cases in which such training or documentation is not reasonably available from another source. If training or documentation is required in accordance with this section, it will be provided in a manner at least at parity with that provided by GTE to its development staff. Training will be conducted at a mutually agreed upon location provided that AT&T shall reimburse GTE for the cost of providing such resources.
- 11.7.2.5. When AT&T selects SCE/SMS AIN Access, GTE shall provide for a secure, controlled access environment on-site, and, if Currently Available, via remote data connections (e.g., dial up, LAN, WAN).
- 11.7.2.6. When AT&T selects SCE/SMS AIN Access, GTE shall allow AT&T to download data forms and/or tables to GTE SCP via GTE SMS without intervention from GTE (e.g., customer subscription).
- 11.7.2.7. Service Control Points (SCP)/Databases shall offer SCE/SMS AIN Access in accordance with requirements of GR-1280-CORE, AIN SCP Generic Requirements.
- 11.7.3. Any mediation to GTE's AIN database that GTE decides to apply, including the application of network management controls determined by GTE to be necessary to protect the SCP from an overload condition, will be done in a competitively neutral and nondiscriminatory basis for all users of the AIN database, including GTE and its customers. For example, any load mediation will affect all links to the STP, including those of GTE or its customers, in a like manner. AT&T agrees to provide forecast information of its AIN requirements sufficient to permit GTE to engineer sufficient capacity on GTE's AIN SCP platform.

- 12.1. **Definition:**
Tandem Switching is the function that establishes a communications path between two switching offices through a third switching office (the tandem switch).
- 12.2. **Technical References** (subject to Section 23.19 of the General Terms and Conditions of this Agreement): GTE shall provide Tandem Switching capabilities where Currently Available and at the same level of quality as GTE provides in its own network, for example:
- 12.2.1. Signaling to establish a tandem connection;
- 12.2.2. Screening and routing;
- 12.2.3. Recording of all billable events;
- 12.2.4. Connectivity to Operator Systems;
- 12.2.5. Access to Toll Free number portability database;
- 12.2.6. All trunk interconnections discussed under the "Network Interconnection" section (e.g., SS7, MF, DTMF, DialPulse, PRI-ISDN, DID, and CAMA-ANI (if appropriate for 911));
- 12.2.7. Connectivity to PSAPs where 911 solutions are deployed and the tandem is used for 911; and
- 12.2.8. Connectivity to transit traffic to and from other carriers.
- 12.2.9. Acceptance of connections (including the necessary signaling and trunking interconnections) between end offices, other tandems, IECs, ICOs, CAPs and CLEC switches.
- 12.2.10. Local tandeming functionality between two end offices including two offices belonging to different CLEC's (e.g., between an AT&T end office and the end office of another CLEC that subtends that tandem).
- 12.2.11. Preservation of CLASS/LASS features and Caller ID as traffic is processed. Additional signaling information and references are provided in Section 10.
- 12.2.12. Billing requirements are specified in Attachment 6 of this Agreement.

- 12.2.13. GTE shall perform routine testing and fault isolation on the underlying switch that is providing Tandem Switching and all its interconnections to the extent such testing and fault isolation is Currently Available. When requested by AT&T, and where Currently Available, the results and reports of the testing shall be made available to AT&T. If AT&T requests testing and fault isolation which GTE does not provide for itself, GTE may agree to perform such testing. If GTE agrees to perform such higher quality testing, GTE shall be entitled to recover costs associated therewith to the extent that such costs are not otherwise included in the cost of the element.
- 12.2.14. GTE shall maintain AT&T's trunks and interconnections associated with Tandem Switching at least at parity to its own trunks and interconnections.
- 12.2.15. Upon AT&T's request, GTE shall provide to AT&T readily available industry standard reports regarding AT&T traffic characteristics that are generated by the tandem switches performing Tandem Switching purchased by AT&T to the extent GTE has the ability to segregate such information. For local and LEC carried intraLATA toll traffic, GTE shall provide Bellcore EMR industry standard formatted records. For interexchange carrier interLATA and intraLATA traffic, GTE shall provide EMI industry standard formatted records. If AT&T desires additional available information beyond that contained in industry standard reports, the Parties shall work together to satisfy AT&T's requirements to the extent GTE is obligated to meet such requirements under Applicable Law.
- 12.2.16. Tandem Switching shall control congestion using, for example, capabilities such as Automatic Congestion Control and Network Routing Overflow. Congestion control provided or imposed on AT&T traffic shall be at parity with controls being provided or imposed on GTE traffic (e.g., GTE shall not block AT&T traffic and leave its traffic unaffected or less affected).
- 12.2.17. Tandem Switching shall route AT&T calls to the GTE or AT&T endpoints or platforms (e.g., operator services and PSAPs) as designated by AT&T for each type of call. AT&T shall pay all costs associated therewith to the extent that such costs are not otherwise included in the cost of the element. Detailed primary and overflow routing plans for all AT&T interfaces, including AT&T traffic on GTE shared trunk groups, available within the GTE switching network shall be mutually agreed to by AT&T and GTE.

- 12.2.18. Tandem Switching shall process originating toll-free traffic received from an AT&T local switch. The Parties shall mutually agree on the methods and implementation procedures to be used to record and bill such traffic.
- 12.2.19. [Intentionally deleted.]
- 12.3. **Interface Guidelines** (subject to Section 23.19 of the General Terms and Conditions of this Agreement): GTE shall provide Interfaces for Tandem Switching at the same level of quality as GTE provides in its own network. For example:
- 12.3.1. Tandem Switching shall provide interconnection to the E911 PSAP where the underlying Tandem is acting as the E911 Tandem.
- 12.3.2. Tandem Switching shall interconnect, with direct trunks, to all carriers with which GTE interconnects.
- 12.3.3. GTE shall provide to the extent Currently Available, all signaling necessary to provide Tandem Switching with no loss of feature functionality.
- 12.3.4. Tandem Switching shall interconnect with AT&T's switch, using two-way trunks, for traffic that is transiting via the GTE network to interLATA or intraLATA carriers. GTE shall record tandem switching events necessary for GTE to bill AT&T for tandem switching and any applicable transport.
- 12.3.4.1. Notwithstanding Section 12.3.4 of this Attachment, where GTE's Tandems do not customarily record tandem switching events, the Parties shall jointly develop acceptable methods of tracking and billing for tandem switching.
- 12.3.5. At AT&T's request, Tandem Switching shall provide overflow routing of traffic from a given trunk group or groups onto another trunk group or groups according to the methodology upon which the Parties agree.
- 12.3.6. Subject to Section 23.19 of the General Terms and Conditions of this Agreement, Tandem Switching shall adhere to the Trunk Interface References provided in the "Network Interconnection" section.
- 12.4. Tandem Switching shall meet or exceed each of the technical references listed in Appendix A to this Attachment 2, under paragraph 12.

13. **Additional References** (subject to Section 23.19 of the General Terms and Conditions of this Agreement):

This Section 13 of Attachment 2 sets forth additional references for unbundled Network Elements offered to AT&T under this Agreement.

13.1. **Cooperative Testing**

13.1.1. **Definition:**

Cooperative Testing means that the Parties shall cooperate with each other upon request or as needed to (1) ensure that any Network Elements provided to AT&T by GTE under this Agreement are in compliance with the requirements of this Agreement, (2) test the overall functionality of Network Elements provided by GTE to AT&T under this Agreement, and (3) ensure that all operational interfaces and processes are in place and functioning properly and efficiently for the provisioning and maintenance of Network Elements so that all appropriate billing data can be provided to AT&T.

13.1.2. **References**

Subject to and in conjunction with Section 23.19 of the General Terms and Conditions of this Agreement, AT&T and GTE will agree upon a process to resolve technical issues relating to interconnection of AT&T's network to GTE's network and Network Elements and Ancillary Functions. The agreed upon process shall include procedures for escalating disputes and unresolved issues up through higher levels of each company's management. If AT&T and GTE do not reach agreement on such a process within sixty (60) days of the commencement of negotiations, upon thirty (30) days notice to the other Party, a Party may submit any issues that have not been resolved by the Parties with respect to such process to the ADR procedures set forth in Section 15 and Attachment 1 of this Agreement unless both Parties agree to extend the time to reach agreement on such issues.

13.1.2.1.	GTE will provision, test, and restore any Network Element that GTE provides to AT&T pursuant to this Agreement, in the same manner and to the same extent as GTE provisions, tests and restores such network elements in GTE's network that provide the same or similar functions and capabilities, and are located in similar central office conditions (e.g., central office or route) as the Network Elements provided to AT&T pursuant to this Agreement.
-----------	---

At AT&T's request, GTE will provide access to Network Elements provided pursuant to this Agreement sufficient for AT&T to test the performance of such Network Element(s) to AT&T's satisfaction, provided, however, GTE shall not be required to provide access where provision of such access would raise or create reasonable network security concerns. In cases where GTE does not allow AT&T access to the Network Element, GTE shall make other arrangements to provide AT&T with test data as the Parties mutually agree.

GTE shall provide AT&T access for testing at the MDF. Such test access shall be sufficient to ensure that the applicable requirements can be tested by AT&T. This access shall be available seven (7) days per week, 24 hours per day.

[Combinations]

- 13.1.2.2. AT&T may test any interfaces, Network Elements or Ancillary Functions and additional requirements provided by GTE pursuant to this Agreement.
- 13.1.2.3. Subject to Section 23.19 of the General Terms and Conditions of this Agreement, GTE shall provide engineering data as requested by AT&T for the loop components as set forth in Sections 2 and 3 of this Attachment which AT&T may desire to test. Such data shall include equipment engineering and cable specifications, signaling and transmission path data. GTE shall provide to AT&T the same type and quality of loop testing information that it provides to itself. Where GTE develops loop testing information as a matter of course, it will make that information available to AT&T where such information is relevant to AT&T's business. Where GTE maintains the internal discretion to test loops as needed, GTE will provide similar testing discretion to AT&T.
- 13.1.2.4. [Intentionally Deleted]
- 13.1.2.5. [Intentionally Deleted]
- 13.1.2.6. GTE shall temporarily provision selected Local Switching features for testing. Where applicable, rates and charges for unbundled ports and features, including but not limited to monthly rates, usage rates and nonrecurring charges, shall apply for the duration of such tests. Within 60 days of the Effective Date of this Agreement AT&T and GTE shall mutually agree on the procedures to be established

between GTE and AT&T to expedite such provisioning processes for feature testing.

- 13.1.2.7. Upon AT&T's request, GTE shall provide technical staff to meet with AT&T representatives to provide required support for Cooperative Testing.
- 13.1.2.8. Dedicated Transport and Loop Feeder may experience alarm conditions due to in-progress tests. GTE shall not remove such facilities from service without obtaining AT&T's prior approval.
- 13.1.2.9. GTE shall conduct tests or maintenance procedures on Network Elements or Ancillary Functions or on the underlying equipment that is then providing a Network Element or Ancillary Function, that may cause a service interruption or degradation if such tests and procedures are at a time that is mutually acceptable to AT&T and GTE.
- 13.1.2.10. GTE shall provide a single point of contact to AT&T that is available 7 days per week, 24 hours per day for trouble status, sectionalization, resolution, escalation, and closure. Such staff shall be adequately skilled to allow expeditious problem resolution.
- 13.1.2.11. [Intentionally Deleted]
- 13.1.2.12. GTE shall participate in Cooperative Testing with AT&T upon AT&T's request to test any operational interface or process used to provide any Network Elements to AT&T.
- 13.1.2.13. AT&T and GTE shall endeavor to complete Cooperative Testing expeditiously.
- 13.1.2.14. During Cooperative Testing, GTE provisioning processes may, at GTE's sound discretion, be enhanced to deliver Network Elements to AT&T in shorter intervals than during subsequent normal service periods upon development of a rate for premium service provisioning.
- 13.1.2.15. GTE shall participate in Cooperative Testing requested by AT&T as mutually required to insure service performance, reliability and customer serviceability of a Network Element.
- 13.1.2.16. AT&T may accept or reject the Network Element ordered by AT&T if upon completion of cooperative acceptance testing, the tested Network Element does not, subject to Section 23.19 of the General

Terms and Conditions of this Agreement, meet the appropriate technical or performance requirements for such Network Element.

13.2. **Performance References** (subject to Section 23.19 of the General Terms and Conditions of this Agreement):

13.2.1. Scope:

This section addresses performance references for Network Elements and Ancillary Functions to provide local service. It includes references for the reliability and availability of Network Elements and Ancillary Functions, and examples of quality parameters such as transmission quality (analog and digital), and speed (or delay) that serve as a reference to the Parties in providing services pursuant to this Agreement. In addition, an overview of service performance references is given.

13.2.1.1. The General Performance References in this section apply to all aspects of Network Elements and Ancillary Functions. Additional references are given in this performance section and in the individual Network Elements sections.

13.2.1.2. GTE shall work cooperatively with AT&T to determine appropriate performance allocations across Network Elements.

13.2.2. Subject to Section 23.19 of the General Terms and Conditions of this Agreement, GTE shall meet or exceed the performance standards and references set forth in the technical references listed in Appendix A to this Attachment 2, under paragraph 13.

13.2.3. Services and Capabilities

13.2.3.1. Network Elements provided to AT&T pursuant to this Agreement shall provide services and capabilities consistent with Section 11.2 of the General Terms and Conditions of this Agreement. GTE shall not intentionally impair or degrade the services and capabilities of any Network Element(s) provided to AT&T pursuant to this Agreement.

13.2.3.1.1. [Intentionally deleted.]

13.2.3.1.2. [Intentionally deleted.]

13.2.3.1.3. [Intentionally deleted.]

13.2.3.1.4. [Intentionally deleted.]

13.2.3.1.5. [Intentionally deleted.]

13.2.3.2. [Intentionally deleted.]

13.2.3.2.1. [Intentionally deleted.]

13.2.3.2.2. [Intentionally deleted.]

13.2.3.2.3. [Intentionally deleted.]

13.2.3.2.4. [Intentionally deleted.]

13.2.3.2.5. [Intentionally deleted.]

13.2.3.2.6. [Intentionally deleted.]

13.2.3.2.7. [Intentionally deleted.]

13.2.4. Specific Technical References for Network Elements (subject to Section 23.19 of the General Terms and Conditions of this Agreement):

13.2.4.1. The following sections 13.2.4.2 through 13.2.4.5.6.2.9.2 describe technical references and performance parameters for Network Elements and Ancillary Functions. The technical references and performance parameters listed in the following sections shall be subject to and interpreted in conjunction with Section 23.19 of the General Terms and Conditions of this Agreement such that failure by GTE to meet any of the technical criteria or performance parameters listed in such sections shall not constitute a breach of contract by GTE. Notwithstanding the above, nothing in this section shall remove or release GTE from its obligations under Section 11.2 of the General Terms and Conditions of this Agreement.

13.2.4.2. Performance Allocation Transmission path impairments may be classified as either analog or digital, and will depend on the nature of the signal transmitted across the Network Element. Analog impairments are introduced on any analog portion of the loop, typically between the NID portion of Loop Distribution and the analog to digital (A/D) conversion, and are usually correlated with the length of the physical plant. Digital impairments are introduced by A/D conversion and by interfaces between digital Network Elements. In addition, noise can be introduced by either analog transmission or the A/D conversion.

- 13.2.4.3. Loop Architecture Parameters
 - 13.2.4.3.1. The following parameters apply to the entire path between the NID and the GTE switch.
 - 13.2.4.3.1.1. No more than 1 A-D conversion.
 - 13.2.4.3.1.2. No more than 1, 2-to-4-wire hybrid.
 - 13.2.4.3.1.3. No voice compression.
 - 13.2.4.3.1.4. No echo cancelers or suppressers.
 - 13.2.4.3.1.5. One digital loss pad per PBX.
 - 13.2.4.3.1.6. No digital gain.
 - 13.2.4.3.1.7. No additional equipment that might significantly increase intermodulation distortion.
 - 13.2.4.4. Transmission Impairments
 - 13.2.4.4.1. Analog Impairments Analog impairments are those introduced on portions of the end-to-end circuit on which communications signals are transmitted in analog format. These portions of the transmission path would typically be between NID and an A/D conversion, most commonly on the metallic loop. The performance on the analog portion of a circuit is typically inversely proportional to the length of that circuit.
 - 13.2.4.4.1.1. Loss
 - 13.2.4.4.1.1.1. Electrical loss is measured using a 1004 Hz 0.0dB one Milliwatt 900 ohm test tone.
 - 13.2.4.4.1.1.2. Off-hook electrical loss between the NID and the switch shall be no more than 8.0 dB for any line, and the mean value for all lines shall be 3.5 dB \pm 0.5 dB. On-hook electrical loss between the NID and the switch shall be no more than 4.0 dB above the off-hook electrical loss for any line.
 - 13.2.4.4.1.2. Idle Channel Circuit Noise
 - 13.2.4.4.1.2.1. Idle channel circuit noise (C-message) is added by analog facilities, by the A/D conversion of signals, by digital processing

equipment (e.g. echo cancelers, digital loss pads), robbed bit signaling, and errors on digital facilities.

- 13.2.4.4.1.2.2. Idle channel circuit noise shall be less than or equal to 18 dB_{BrnC}.
- 13.2.4.4.1.3. Talker Echo
 - 13.2.4.4.1.3.1. The primary source of echo is improper impedance-matching at the 2-to-4 wire hybrid in the GTE network. The impact on customer perception is a function of both echo return loss and delay.
 - 13.2.4.4.1.3.2. Echo Return Loss (ERL) shall be greater than 26dB to a standard termination (900 ohms, 2.16 mFd), and greater than 14 dB to a telephone set off-hook. Singing Return Loss (SRL) shall be greater than 21dB to a standard termination, and greater than 11 dB to a telephone set off-hook.
- 13.2.4.4.1.4. Listener Echo
 - Listener echo is a double reflection of a transmitted signal at two different impedance mismatches in the end-to-end connection. While in extreme cases it can degrade voice transmission performance, listener echo is primarily an issue for voiceband data. The requirements on Talker Echo shall apply to Listener Echo.
- 13.2.4.4.1.5. Propagation and Processing Delay
 - 13.2.4.4.1.5.1. Propagation delay is the delay involved in transmitting information from one location to another. It is caused by processing delays of equipment in the network and delays associated with traveling across transmission facilities.
 - 13.2.4.4.1.5.2. GTE shall cooperate with AT&T to limit total service propagation and processing delay to levels at parity with that within the GTE local network.
- 13.2.4.4.1.6. Signal-to-Noise Ratio
 - 13.2.4.4.1.6.1. The Signal-to-Noise Ratio (S/N) is a critical parameter in determining voiceband data performance. It is typically measured with a 1004 Hz tone.
 - 13.2.4.4.1.6.2. GTE must provide on the Loop a signal-to-noise ratio of at least 37 dB between the NID and the end office.
- 13.2.4.4.1.7. C-Notched Noise
 - The requirements for Signal-to-Noise Ration shall apply to C-

Notched Noise.

- 13.2.4.4.1.8. Attenuation Distortion
- 13.2.4.4.1.8.1. Attenuation distortion, also known as frequency distortion or gain slope, measures the variations in loss at different frequencies across the voice frequency spectrum (200 Hz - 3400 Hz). It is measured by subtracting the loss at 1004 Hz from the loss at the frequency of interest.
- 13.2.4.4.1.8.2. Attenuation distortion from the NID to the switch shall be within the range ± 0.5 dB for frequencies between 304 and 3004 Hz; from the switch to NID attenuation distortion shall be within the range ± 0.5 dB for frequencies between 204 Hz and 3004 Hz. In addition, attenuation distortion shall remain within the range +1dB/-3dB for frequencies between 200 Hz and 3500 Hz.
- 13.2.4.4.1.9. Envelope Delay Distortion
- 13.2.4.4.1.9.1. Envelope Delay Distortion (EDD) measures the difference in transit time of signals at different frequencies. EDD is measured relative to the transit time of a 1704 Hz. tone, and is given in microseconds. EDD is used as an approximation of the group delay of the channel.
- 13.2.4.4.1.9.2. EDD shall be: 1704 Hz to 604 Hz -- ≤ 350 msec.; 1704 Hz to 2804 Hz -- ≤ 195 msec.; 1704 Hz to 204 Hz -- ≤ 580 msec.; 1704 Hz to 3404 Hz -- ≤ 400 msec.
- 13.2.4.4.1.10. Phase Jitter
- 13.2.4.4.1.10.1. Phase jitter measures the unwanted angular modulation of a signal. It is caused by noise or the actual modulation of the signal by another unwanted signal. It displaces the zero crossings of a signal. It is measured in terms of peak-to-peak deviations of a 1004 Hz. tone from its nominal zero crossings, and in a particular frequency band (20-300 Hz and either 4-300 Hz or 2-300 Hz). Phase jitter impacts voiceband data performance and can make modems more susceptible to other impairments, including noise.
- 13.2.4.4.1.10.2. From the NID to the interexchange carrier point of termination, phase jitter shall be $<1.5^\circ$ point-to-point in the 20-300 Hz band, and $<1.8^\circ$ point-to-point in the 4-300 Hz. band.

- 13.2.4.4.1.11. Amplitude Jitter
- 13.2.4.4.1.11.1. Amplitude jitter is any deviation of the peak value of a 1004 Hz signal from its nominal value. Excessive amounts can impair voiceband data performance. It is primarily caused by noise but can also be caused by phase jitter, gain hits, or single frequency interference.
- 13.2.4.4.1.11.2. In NID-interexchange carrier point of termination, $\leq 2.5\%$ of amplitude jitter is permitted in the 20-300 Hz band and $\leq 2.9\%$ in the 4-300 Hz band.
- 13.2.4.4.1.12. Intermodulation Distortion
- 13.2.4.4.1.12.1. Intermodulation distortion (IMD) measures non-linear distortions of a signal. It compares the power of harmonic tones to the power of the transmitted tones. It is measured for both the 2nd and 3rd harmonics of the transmitted tones. IMD is caused by compression or clipping and can impair voiceband data performance. Both 2nd and 3rd order IMD between the NID and end office must be $\geq 52\text{dB}$.
- 13.2.4.4.1.13. Impulse Noise
- 13.2.4.4.1.13.1. Impulse noise is a sudden and large increase in noise on a channel for a short duration of time. Impulse noise is measured as a count of the number of times a noise threshold is exceeded during a given time period (typically 5 or 15 minutes). It is caused by protection switching, maintenance activities, electromechanical switching systems, digital transmission errors, and line coding mismatches. Impulse noise sounds like clicking noises or static on voice connections. Impulse noise impairs voiceband data performance.
- 13.2.4.4.1.13.2. The NID to interexchange carrier point of termination portions of connections shall introduce no impulse noise events within 6dB of the received signal power on 93% of all 15 minute connections. In addition, there shall be no more than 1 impulse noise event within 6 dB of the received signal power during any 30-minute period.
- 13.2.4.4.1.14. Phase Hits
- 13.2.4.4.1.14.1. Phase hits are a sudden change in the phase of a signal lasting at least 4 msec. Phase hits are measured using a threshold which indicates how much the phase of the signal has changed with respect to its nominal phase. Phase hits are caused by protection

switching and slips or other synchronization errors. Phase hits can impair voiceband data performance.

- 13.2.4.4.1.14.2. Between the NID and interexchange carrier point of termination, 99.75% of all 15-minute connections shall have no phase hits exceeding 10°. In addition, there shall be no more than 1 phase hit exceeding 10° in any 30-minute period.
- 13.2.4.4.1.15. Gain Hits
- 13.2.4.4.1.15.1. Gain hits are sudden changes in the level of a signal that last at least 4 msec. Gain hits are measured against a threshold of typically 2-5 dB relative to the signal's nominal level. Gain hits are usually caused by protection switches and can impair voiceband data performance.
- 13.2.4.4.1.15.2. Between the NID and the interexchange carrier point of termination, 99.5% of all 15-minute connections shall have no gain hits exceeding 3 dB. In addition, there shall be no more than 1 gain hit exceeding 3 dB in any 30-minute period.
- 13.2.4.4.1.16. Dropouts
- 13.2.4.4.1.16.1. Dropouts are drops in the level of a signal of 12 dB or more for at least 4 msec. They are caused by protection switching events, radio fading, and conditions causing digital carrier systems to lose frame. Dropouts are critical for voiceband data performance but, if severe enough, will also affect voice quality.
- 13.2.4.4.1.16.2. Between the NID and the interexchange carrier point of termination, 99.9% of all 15-minute connections shall have no dropouts and in addition, no connection shall suffer more than 1 dropout in any 60-minute period.
- 13.2.4.4.1.17. Frequency Shift
- 13.2.4.4.1.17.1. Frequency shift measures any frequency changes that occur when a signal is transmitted across a channel. It is typically measured using a 1004 Hz tone. Frequency shift has very little impact on voice or voiceband data performance; however, round-trip frequency shifts can affect the ability of echo cancelers to remain converged.
- 13.2.4.4.1.17.2. No more than 0.2 Hz frequency shift shall be on any connection. In addition, 99.5% of all calls shall have frequency shift < 0.1 Hz.

13.2.4.4.1.18. Crosstalk

13.2.4.4.1.18.1. Crosstalk is the presence of signals from other telephone connections on a circuit. Crosstalk can be either intelligible, when speech from other connections can be heard and understood, or unintelligible. Crosstalk is caused by inter-channel interference on the transmission system. Crosstalk is difficult to measure: it requires correlating signals on different circuits or using human listeners to identify its presence. Trouble reports may be used to estimate the probability of crosstalk.

13.2.4.4.1.18.2. 99% of Loop(s) shall have probability $\leq 0.1\%$ of experiencing crosstalk exceeding -65 dBm0.

13.2.4.4.1.19. Clipping

13.2.4.4.1.19.1. Clipping occurs when part of a transmitted signal is dropped and does not reach the receiving portion on a connection. It can be caused by Digital Speech Interpolation (DSI) equipment used in Digital Circuit Multiplication Systems (DCMS) which increase the amount of traffic that transmission facilities carry, and by echo cancelers or echo suppressers.

No clipping incidents shall occur on any call.

13.2.4.4.2. Digital Impairments

Digital impairments occur in the signal wherever it is transmitted in digital format. These errors are usually introduced upon conversion of the signal from analog to digital, as well as at interfaces between digital components. While many digital impairments have little impact on subjective voice quality, they can impact voiceband data performance.

13.2.4.4.2.1. Signal Correlated Distortion

13.2.4.4.2.1.1. Signal correlated distortion (SCD) is unwanted noise or distortion introduced into a signal through the conversion of a signal from analog to digital format or through digital processing that changes the transmitted signal. SCD affects performance when a sign is being transmitted. The primary sources of SCD are signal encoders, echo cancelers, digital loss pads, and robbed bit signaling. SCD affects both voice and voiceband data performance.

- 13.2.4.4.2.1.2. The NID-to-end-office connection shall allow:
 - 13.2.4.4.2.1.2.1. A maximum of 1 A/D conversion, using 64Kbps m-law (m=255) PCM;
 - 13.2.4.4.2.1.2.2. No voice compression;
 - 13.2.4.4.2.1.2.3. No echo cancellation; and
 - 13.2.4.4.2.1.2.4. Robbed bit signaling only if SS7 or ISDN are not used.
- 13.2.4.4.2.2. Slips
 - 13.2.4.4.2.2.1. Slips occur when a frame of digital data is either deleted or repeated because of differences in the clocks used to synchronize digital facilities. Slips sound like clicks or pops on voice calls and have major impact on voiceband data performance.
 - 13.2.4.4.2.2.2. The NID-to-interexchange carrier point of termination portion of connections shall have fewer than 0.45 slips every 24 hours on average.
- 13.2.4.4.2.3. Digital Timing Jitter and Wander
 - 13.2.4.4.2.3.1. Digital timing jitter is the unwanted phase modulation of digital signals at rates above 10 Hz. Wander is the unwanted phase modulation of digital signals at rates below 10 Hz. Digital timing jitter is caused by imperfections in the timing recovery process of repeaters and the stuffing synchronization process used by multiplexer/demultiplexers. Wander is caused by slowly varying changes in digital signal phase due to clock frequency offset and drift, changes in propagation delay of terrestrial facilities due to temperature changes and changes in the distance of satellites from the earth. These events have a major impact on voiceband data performance.
 - 13.2.4.4.2.3.2. The maximum digital timing jitter allowed in the 10 Hz to 8 kHz frequency band at any network interface or any terminal equipment in the network is 5 Unit Intervals (UI). The maximum digital timing jitter allowed in the 8 kHz to 40 kHz frequency band is 0.1 UI. The objective for wander is less than 28 UI at any network interface or terminal equipment.
- 13.2.4.4.2.4. DS-1 Errored Seconds
 - 13.2.4.4.2.4.1. An Errored Second (ES) on a DS-1 facility is any second during which at least 1 bit is in error. The impact of an ES on

performance depends on the number of errors that occur during a second. Typically, voice performance is not significantly impacted by ES but they can cause errors in voiceband data transmissions.

13.2.4.4.2.4.2. Each GTE network shall have less than 20 ESs per 24 hour period.

13.2.4.4.2.5. DS-1 Severely Errored Seconds

13.2.4.4.2.5.1. A severely Errored Second (SES) is any second during which a DS-1 has an error rate exceeding 0.001. An SES can be caused by a loss of framing, a slip, or a protection switch. SESs have impacts on both voice and voiceband data performance. For voice, an SES will sound like a burst of noise or static. SESs that occur during a voiceband data transmission cause a significant burst of errors and can cause modems to retrain.

13.2.4.4.2.5.2. The digital portion of each NID to POP connection shall have less than 2 SESs per 24 hour period).

13.2.4.4.2.6. Short Failure Events

13.2.4.4.2.6.1. A Short Failure Event (SFE) is a Loss of Frame (LOF) event of less than two minutes' duration. An LOF event is declared when, on detection of a Loss of Signal (LOS) or Out-of-Frame (OOF), a rise-slope-type integration process starts that declares a LOF after 2.5 ± 0.5 sec. of continuous LOS or OOF. If the LOS or OOF is intermittent, the integration process shall decay at a slope of 1/5 the rise slope during the period when the signal is normal. Thus, if the ratio of a LOS or OOF to a normal signal is greater than 1/2, a LOF will be declared. A LOS condition shall be declared when the Network Channel Terminating Equipment has determined that 175 ± 75 successive pulse positions with no pulses of either positive or negative polarity have occurred. An OOF condition shall be declared when either Network equipment or Digital Terminal Equipment detects errors in the framing pattern.

13.2.4.4.2.6.2. There shall be fewer than 1 SFE per month.

13.2.4.5. Service Availability and Reliability

Availability refers to the time period during which the service is up and usable for its intended purpose. Reliability refers to the probability that a task will be completed successfully, given that it is successfully begun.

13.2.4.5.1. Blocked Calls

- 13.2.4.5.1.1. Blocking is the fraction of call origination attempts denied service during a stated measurement period. Blocking occurs because of competition for limited resources within the network.
- 13.2.4.5.1.2. For intraLATA toll service as well as for local exchange service, the blocking level from originating network interface (NID) to terminating NID shall not exceed 1% in any hour, except under conditions of service disruption. For access to or egress from the AT&T long distance network, the blocking rate shall not exceed 0.5% in any hour, except under conditions of service disruption.
- 13.2.4.5.2. Blocked Dial Tone
- 13.2.4.5.2.1. Blocked dial tone occurs when the subscriber does not receive dial tone within 3 seconds of going off-hook.
- 13.2.4.5.2.2. Customers shall not experience more than 0.1% dial tone blocking during average busy season busy hour (ABSBH).
- 13.2.4.5.3. Downtime
Downtime is the period of time that a system is in a failed state.
- 13.2.4.5.3.1. The average downtime for all subscriber Loop(s) shall be less than 49 minutes per year. The maximum downtime for 99% of all subscriber Loop(s) shall be less than 74 minutes per year.
- 13.2.4.5.3.2. The average downtime for an end office switch shall be less than 3 minutes per year. The average downtime for individual trunks shall be less than 28 minutes per year. The average downtime for digital trunk groups shall be less than 20 minutes per year. The average downtime for an individual line appearance at the switch shall be less than 28 minutes per year. The average downtime for a Remote Terminal (RT) shall be less than 17 minutes per year. The average downtime for an individual line on a Remote Terminal (RT) shall be less than 13 minutes per year.
- 13.2.4.5.3.3. [Intentionally deleted.]
- 13.2.4.5.3.4. There shall be no downtime due to power failures at the switch.
- 13.2.4.5.3.5. The probability of a stable call being cut off shall be less than 20 cutoffs per one million 1 minute calls.
- 13.2.4.5.3.6. The rate of ineffective machine attempts at the end office shall be less than 0.0005 (5 failures per 10,000 call attempts).

- 13.2.4.5.3.7. GTE shall meet all references for private line services in TR-NWT-000335, ANSI T1.512-1994, and AT&T Technical References as listed in this Section 13.2.
- 13.2.4.5.4. Dial Tone Delay
 - 13.2.4.5.4.1. Dial-Tone Delay is the time period between a customer off-hook and the receipt of dial tone from an originating end office. Dial-Tone Delay has a significant effect on customer opinion of service quality.
 - 13.2.4.5.4.2. The average dial-tone delay shall not exceed 0.6 seconds. At most 0.5% of calls during the average-season busy hour (ABSBH) shall experience dial-tone delay greater than 3 seconds. At most 8% of calls during the ten-high-day busy hour (THDBH) shall experience dial-tone delay greater than 3 seconds. At most 10% of calls during the high-day busy hour (HDBH) shall experience dial-tone delay greater than 3 seconds.
- 13.2.4.5.5. Dial Tone Removal
 - 13.2.4.5.5.1. Dial tone removal is the time between recognition of the first address digit to the removal of dial tone on the line.
The maximum dial tone removal interval shall be ≤ 500 milliseconds.
- 13.2.4.5.6. Post Dial Delay
 - 13.2.4.5.6.1. Post Dial Delay (PDD) is the amount of time a caller must wait after entering or dialing the last digit of a Destination Telephone Number (DTN) before hearing a valid audible network response. The PDD for an end user is measured from the time the caller has pressed or dialed the last digit of a DTN until receipt of an audible network response.
 - 13.2.4.5.6.2. The references given reflect an end-to-end CCS7 protocol for AT&T end users. Where a mixture of CCS7 and inband (MF) signaling protocols are employed, an increase in the PDD can be expected.
 - 13.2.4.5.6.2.1. PDD 1 - A - Intra AT&T LSO
 - 13.2.4.5.6.2.1.1. Intra-LSO calls do not employ external signaling protocols. The PDD for intra-LSO calls flows are dependent upon the processor cycle time and traffic load conditions. This PDD is assumed to be between customers on the same AT&T LSO, between the Remote

Switch Modules (RSMs) on the same Host, or between an RSM and 5ESS Host customers.

- 13.2.4.5.6.2.1.2. The objective for intra-LSO PDD is less than 310 milliseconds for 50% of all calls and less than 460 milliseconds for 95% of all calls.
- 13.2.4.5.6.2.2. PDD1 - B - AT&T LSO to Another AT&T Local LSO
- 13.2.4.5.6.2.2.1. The signaling protocols from an AT&T LSO to another AT&T LSO are assumed to employ out-of-band Common Channel Signaling System 7 (CCS7) format. Local calls, that is, calls from an AT&T LSO to another AT&T LSOs are assumed to have no more than one pair of Signaling Transfer Point Switches (STPSs) and no more than one data base dip.
- 13.2.4.5.6.2.2.2. This PDD is expected to be better than the AT&T Long Distance objective with an average PDD of $\leq .870$ seconds with $95\% \leq 1.34$ seconds.
- 13.2.4.5.6.2.3. PDD1 - C - AT&T LSO to Other LSO
- 13.2.4.5.6.2.3.1. Calls from an AT&T LSO to other LSOs are dependent upon the interface agreements between AT&T and the LSO service provider and may employ CCS7, inband (MF) or a combination of both protocols.
- 13.2.4.5.6.2.3.2. Calls from an AT&T LSO to another LSO via the Public Switched Telecommunications Network (PSTN), using end-to-end CCS7 signaling protocols, can expect to meet the AT&T PDD objectives of an average of 2.0 seconds with 95% in ≤ 2.5 seconds. Calls from an AT&T LSO via the PSTN to LSOs outside the local service area are assumed to use CCS7 signaling protocols to the AT&T #4ESS. The egress signaling protocols from the AT&T Switched Network (ASN) to the many different local telephone company service providers however does not necessarily utilize CCS7 signaling. There are three basic egress signaling configuration. They are:
 - 13.2.4.5.6.2.3.2.1. Network Inter-Connect, CCS7 between AT&T and the local telephone company.
 - 13.2.4.5.6.2.3.2.2. Inband Multifrequency (MF) signaling protocols without a GTE egress tandem in the connection.
 - 13.2.4.5.6.2.3.2.3. Inband MF signaling protocols with a GTE egress tandem in the connection.

- 13.2.4.6.3.2.3.2.3.1 Calls from an AT&T LSO to other LSOs outside the local service area are assumed to have multiple STPSs for 1+ traffic in the access and ASN portion of the connection. The egress from the ASN for 1+ traffic is again dependent upon the interface agreements in that service area and may consist of CCS7 or inband MF protocols.
- 13.2.4.6.3.2.3.2.3.2 Calls from an AT&T's LSO to another AT&T LSO with a mixture of CCS7 or all inband signaling protocols are expected to receive PDDs on the average of 2.9 seconds with 95% in ≤ 6.5 seconds.
- 13.2.4.5.6.2.4. PDD2 - AT&T LSO to Operator Services
 - 13.2.4.5.6.2.4.1. The signaling protocols between an AT&T LSO and the AT&T ASN 5ESS® Operator Services Position Systems (OSPS) will employ IN-band Feature Group C Modified Operator Services Multifrequency signaling format. As with 1+ traffic, the egress from the ASN to the local service providers LSO is dependent upon the interface.
 - 13.2.4.5.6.2.5. PDD2 - A - AT&T LSO to 5ESS® OSPS 0 Only
 - 13.2.4.5.6.2.5.1. When a "0" has been entered by the customer, timing is applied in the absence of a DTMF "#". If a "#" is not entered, the objective is for the timer to expire in 4 seconds +/- 1 second. After the timer has expired, or the "#" has been entered, the average PDD shall not exceed 2.2 seconds.
 - 13.2.4.5.6.2.6. PDD2 - B - 0 Plus Calls
 - 13.2.4.5.6.2.6.1. On calls where analysis of the first 6 digits (area code + central office code) is required, the PDD shall not exceed 2.0 seconds on the average, and 2.5 seconds in 95% of all occurrences. For calls that require analysis of the 10-digits CALLED number and the 7 digits of calling number (ANI, e.g. Automatic Charge Quotation Service) the PDD is expected to be 4.5 seconds on the average and < 5.0 seconds in 95% of all occurrences. These delays are based on the calling customer receiving a network response as described above, specifically the calling card alerting tone from the 5ESS® OSPS. The remaining call completion PDD to the DTN, after the customer has completed the Operator Service function, will take the form of the PDDs discussed in PDD1-C.
 - 13.2.4.5.6.2.7. Impact of Local Number Portability (LNP)
 - 13.2.4.5.6.2.7.1. Local Number Portability will increase PDDs. If a call forwarding option is used as an interim solution for LNP, the delay due to

additional switching in the local access is estimated to be 0.3 seconds (mean) and 0.4 seconds (95th percentile) in addition to the PDDs described earlier. These estimates assumes CCS7 signaling between LSOs. If inband signaling is used between LSOs, the PDD will be increased by 1.9 to 3.6 (1.7+1.9) seconds compared to the PDDs provided in the section on Post Dial Delay.

- 13.2.4.5.6.2.8. Custom Local Area Subscriber Services (CLASS)
- 13.2.4.5.6.2.8.1. CLASSsm features such as Calling Name Delivery can contribute to the PDD of a call. This delay is caused by the additional time (GTE option) before the ringing interval commences. This default delay is 3 seconds. Optional settings are available in 1 second intervals from 1 to 6 seconds. Calls to DTNs that have CLASSSM features, particularly with calling name delivery, can expect to experience from 1 to 6 seconds (3 seconds default) of additional PDD compared to the PDDs shown for PDD1-C.
- 13.2.4.5.6.2.9. Partial Dial Timing
- 13.2.4.5.6.2.9.1. The interval between each information digit from a customer's line, until the LSO or switching system has determined that the digit string is incomplete.
- 13.2.4.5.6.2.9.2. For customer lines, partial dial timing shall be ≥ 16 seconds and ≤ 24 seconds. For trunks, inband signaling time-out shall be ≥ 5 seconds and ≤ 20 seconds.
- 13.2.5. [Intentionally deleted.]
- 13.2.5.1. [Intentionally deleted.]
- 13.2.5.1.1. [Intentionally deleted.]
- 13.2.5.1.2. [Intentionally deleted]
- 13.3. **Protection, Restoration, and Disaster Recovery**
- 13.3.1. Scope:
This Section refers specifically to references on the use of redundant network equipment and facilities for protection, restoration, and disaster recovery.

- 13.3.2. Technical References (subject to Section 23.19 of the General Terms and Conditions of this Agreement):
- 13.3.2.1. GTE shall provide protection, restoration, and disaster recovery capabilities at parity with those capabilities provided for GTE's own services, facilities and equipment (e.g., equivalent circuit pack protection ratios, facility protection ratios).
- 13.3.2.2. GTE shall provide Network Elements and Ancillary Functions equal priority in protection, restoration, and disaster recovery as provided to GTE's own services, facilities and equipment.
- 13.3.2.3. GTE shall provide Network Elements and Ancillary Functions equal priority in the use of spare equipment and facilities as provided to GTE's own services, facilities and equipment.
- 13.3.2.4. Where AT&T designates an AT&T customer priority list, GTE shall restore Network Elements provided to AT&T, which have been identified by the Parties as serving the customers on the priority list, in accordance with AT&T's priority designation. AT&T will work jointly with GTE in identifying those Network Elements associated with the priority customer list.

13.4. **Synchronization**

13.4.1. Definition:

Synchronization is the function which keeps all digital equipment in a communications network operating at the same average frequency. With respect to digital transmission, information is coded into discrete pulses. When these pulses are transmitted through a digital communications network, all synchronous Network Elements are traceable to a stable and accurate timing source. Network synchronization is accomplished by timing all synchronous Network Elements in the network to a stratum 1 traceable timing source so that transmission from these network points have the same average line rate.

13.4.2. Technical References (subject to Section 23.19 of the General Terms and Conditions of this Agreement):

The following references are applicable to the case where GTE provides synchronization to equipment that AT&T owns and operates within a GTE location. In addition, these references apply to synchronous equipment that is owned by GTE and is used to provide a Network Element to AT&T.

- 13.4.2.1. The synchronization of clocks within digital networks is divided into two parts: intra-building and inter-building. Within a building, a single clock is designated as the Building Integrated Timing Supply (BITS), which provides all of the DS1 and DS0 synchronization references required by other clocks in such building. This is referred to as intra-building synchronization. The BITS receives synchronization references from remotely located BITS. Synchronization of BITS between buildings is referred to as inter-building synchronization.
- 13.4.2.2. To implement a network synchronization plan, clocks within digital networks are divided into four stratum levels. All clocks in strata 2, 3, and 4 are synchronized to a stratum 1 clock, that is, they are traceable to a stratum 1 clock. A traceable reference is a reference that can be traced back through some number of clocks to a stratum 1 source. Clocks in different strata are distinguished by their free running accuracy or by their stability during trouble conditions such as the loss of all synchronization references.
- 13.4.2.2.1. Intra-Building
- 13.4.2.2.1.1. Within a building, there are different kinds of equipment that require synchronization at the DS1 and DS0 rates. Synchronization at the DS1 rate is accomplished by the frequency synchronizing presence of buffer stores at various DS1 transmission interfaces. Synchronization at the DS0 rate is accomplished by using a composite clock signal that phase synchronizes the clocks. Equipment requiring DS0 synchronization frequently does not have adequate buffer storage to accommodate the phase variations among different equipment. Control of phase variations to an acceptable level is accomplished by externally timing all interconnecting DS0 circuits to a single clock source and by limiting the interconnection of DS0 equipment to less than 1,500 cable feet. Therefore, a BITS shall provide DS1 and composite clock signals when appropriate. The composite signal is a 64-kHz 5/8th duty cycle, return to zero with a bipolar violation every eighth pulse (B8RZ).
- 13.4.2.2.2. Inter-Building
- 13.4.2.2.2.1. Subject to Section 23.19 of the General Terms and Conditions of this Agreement, GTE shall provide inter-building synchronization at the DS1 rate, and the BITS shall accept the primary and secondary synchronization links from BITS in other buildings. From hierarchical considerations, the BITS shall be the highest stratum clock within the building and GTE shall provide operations

capabilities (this includes, but is not limited to: synchronization reference provisioning; synchronization reference status inquiries; timing mode status inquiries; and alarm conditions).

13.4.3. Synchronization Distribution References (subject to Section 23.19 of the General Terms and Conditions of this Agreement):

- 13.4.3.1. Central office BITS shall contain redundant clocks meeting or exceeding the references for a stratum 2 clock as specified in ANSI T1.101-1994 and Bellcore TR-NWT-001244 Clocks for the Synchronized Network: Common Generic Criteria.
- 13.4.3.2. Central office BITS shall be powered by primary and backup power sources to the extent GTE utilizes such backup power sources in GTE's own network.
- 13.4.3.3. If both reference inputs to the BITS are interrupted or in a degraded mode (meaning off frequency greater than twice the minimum accuracy of the BITS, loss of frame, excessive bit errors, or in Alarm Indication Signal), then the stratum clock in the BITS where Currently Available, shall provide the necessary bridge in timing to allow the network to operate without a frame repetition or deletion (slip free) with better performance than 1 frame repetition or deletion (slip) per week.
- 13.4.3.4. DS1s multiplexed into a SONET synchronous payload envelope within an STS-n (where n is defined in ANSI T1.105-1995) signal shall not be used as reference facilities for network synchronization.
- 13.4.3.5. The total number of Network Elements cascaded from the stratum 1 source shall be minimized in accordance with GTE's standards for such minimization.
- 13.4.3.6. To the extent that GTE provides such stratum level to itself, a Network Element shall receive the synchronization reference signal only from another Network Element that contains a clock of equivalent or superior quality (stratum level).
- 13.4.3.7. [Intentionally deleted.]
- 13.4.3.8. Where possible, all primary and secondary synchronization facilities shall be physically diverse (this means the maximum available physical separation of synchronization equipment and cabling).

- 13.4.3.9. No timing loops shall be formed in any combination of primary and secondary facilities unless GTE utilizes such combinations in its network.
- 13.4.3.10. GTE shall continuously monitor the BITS for synchronization related failures or degradation to the extent GTE provides such monitoring to itself.
- 13.4.3.11. GTE shall continuously monitor all equipment transporting synchronization facilities for synchronization related failures or degradation to the extent GTE provides such monitoring to itself.
- 13.4.3.12. For non-SONET equipment, GTE shall provide synchronization facilities which, at a minimum, comply with the standards set forth in ANSI T1.101-1994.
For SONET equipment, GTE shall provide synchronization facilities that have time deviation (TDEV) for integration times greater than 0.05 seconds and less than or equal to 10 seconds, that is less than or equal to 10 nanoseconds. TDEV, in nanoseconds, for integration times greater than 10 seconds and less than 1000 seconds, shall be less than 3.1623 times the square-root of the integration time. For example, for integration times of 25 seconds, TDEV shall be less than 15.8 nanoseconds.

13.5. **SS7 Network Interconnection**

- 13.5.1. Definition:
SS7 Network Interconnection is the Interconnection of GTE Signal Transfer Points (STPs) with AT&T STPs or AT&T local or tandem switching systems, for the purpose of providing local exchange or exchange access services. This connectivity enables the exchange of SS7 messages between AT&T local or tandem switching systems and GTE's local or tandem switching systems, and between AT&T local or tandem switching systems and other third-party local or tandem switching systems with signaling connectivity to the same STPs. This connectivity also enables the exchange of messages between AT&T local or tandem switching systems, and GTE call-related databases.

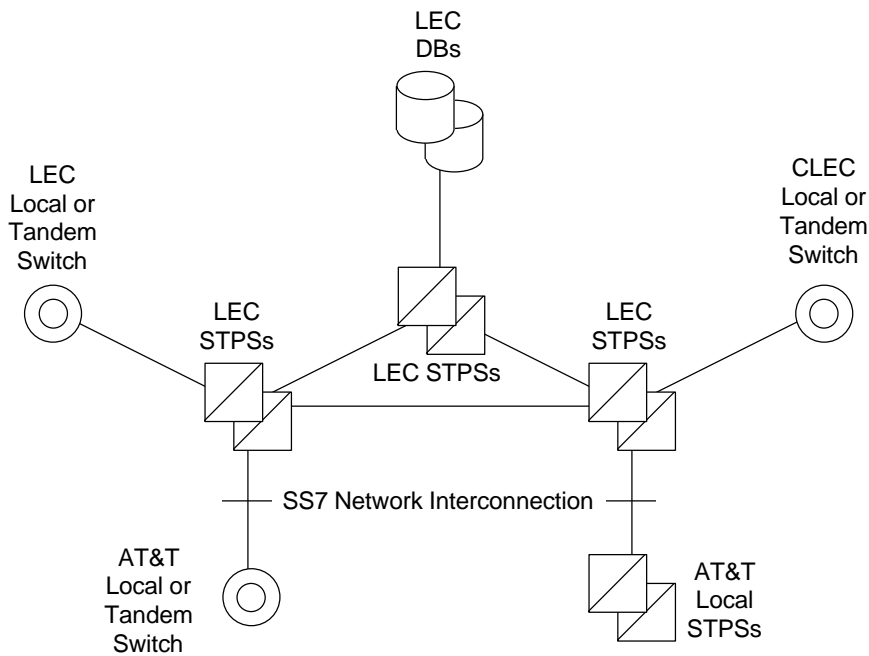

Figure 3. SS7 Network Interconnection

- 13.5.2. Technical References (subject to Section 23.19 of the General Terms and Conditions of this Agreement): GTE shall provide SS7 Network Interconnection at the same level of quality as GTE provides for such network interconnection in its own network. For example:
- 13.5.2.1. SS7 Network Interconnection provides connectivity to all components of the GTE SS7 network. These include:
 - 13.5.2.1.1. GTE local or tandem switching systems;
 - 13.5.2.1.2. GTE DBs; and
 - 13.5.2.1.3. Other third-party local or tandem switching systems.
 - 13.5.2.2. The connectivity provided by SS7 Network Interconnection fully supports the functions of GTE switching systems and DBs and AT&T or other third-party switching systems with A-link access to the GTE SS7 network.
 - 13.5.2.3. In particular Figure 4 depicts a circumstance where SS7 Network Interconnection provides transport for certain types of Transaction Capabilities Application Part (TCAP) messages. If traffic is routed based on dialed or translated digits between an AT&T local switching system and a GTE or other third-party local switching

system, either directly or via a GTE tandem switching system, then GTE SS7 network conveys via SS7 Network Interconnection the TCAP messages that are necessary to provide Call Management services (Automatic Callback, Automatic Recall, and Screening List Editing) between the AT&T local STPSs and the GTE or other third-party local switch.

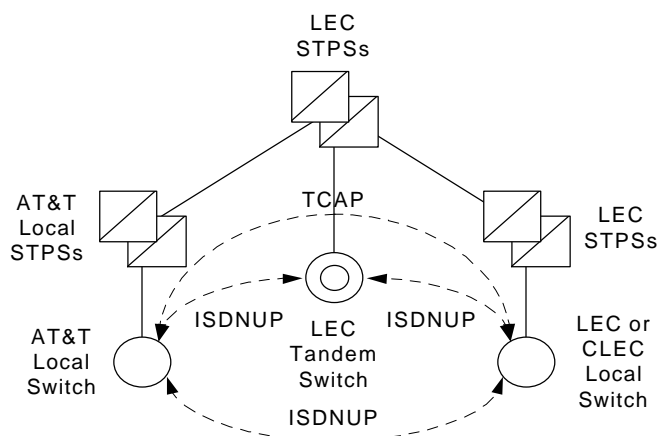

Figure 4. Interswitch TCAP Signaling for SS7 Network Interconnection

- 13.5.2.4. When the capability to route messages based on Intermediate Signaling Network Identifier (ISNI) is generally available on GTE STPSs, the GTE SS7 Network also conveys TCAP messages using SS7 Network Interconnection in similar circumstances where the GTE switch routes traffic based on a Carrier Identification Code (CIC).
- 13.5.2.5. SS7 Network Interconnection shall provide all functions of the MTP as specified in ANSI T1.111. This includes Signaling Data Link functions, as specified in ANSI T1.111.2; Signaling Link functions, as specified in ANSI T1.111.3; and Signaling Network Management functions, as specified in ANSI T1.111.4.
- 13.5.2.6. SS7 Network Interconnection shall provide all functions of the SCCP necessary for Class 0 (basic connectionless) service, as specified in ANSI T1.112 (Reference 13.5.2.5). In particular, this includes Global Title Translation (GTT) and SCCP Management procedures, as specified in T1.112.4. Where the destination signaling point is a GTE switching system or DB, or is another

third-party local or tandem switching system directly connected to the GTE SS7 network, SS7 Network Interconnection shall include final GTT of messages to the destination and SCCP Subsystem Management of the destination. Where the destination signaling point is an AT&T local or tandem switching system, SS7 Network Interconnection shall include intermediate GTT of messages to a gateway pair of AT&T local STPSs, and shall not include SCCP Subsystem Management of the destination.

- 13.5.2.7. SS7 Network Interconnection shall provide all functions of the Integrated Services Digital Network User Part (ISDNUP), as specified in ANSI T1.113 (Reference 13.5.2.5).
- 13.5.2.8. SS7 Network Interconnection shall provide all functions of the TCAP, as specified in ANSI T1.114 (Reference 13.5.2.5).
- 13.5.2.9. If and when Internetwork MTP Routing Verification Test (MRVT) and SCCP Routing Verification Test (SRVT) become approved ANSI standards and available capabilities of GTE STPSs, SS7 Network Interconnection shall provide these functions of the OMAP.
- 13.5.3. Link Interface References (subject to Section 23.19 of the General Terms and Conditions of this Agreement):
 - 13.5.3.1. GTE shall offer the following SS7 Network Interconnection options to connect AT&T or AT&T-designated local or tandem switching systems or STPSs to the GTE SS7 network:
 - 13.5.3.1.1. A-link interface from AT&T local or tandem switching systems; and
 - 13.5.3.1.2. D-link interface from AT&T STPSs.
 - 13.5.3.2. Subject to Section 23.19 of the General Terms and Conditions of this Agreement, each interface shall be provided by one or more sets (layers) of signaling links, as follows:

13.5.3.2.1. An A-link layer shall consist of two links, as depicted in Figure 5.

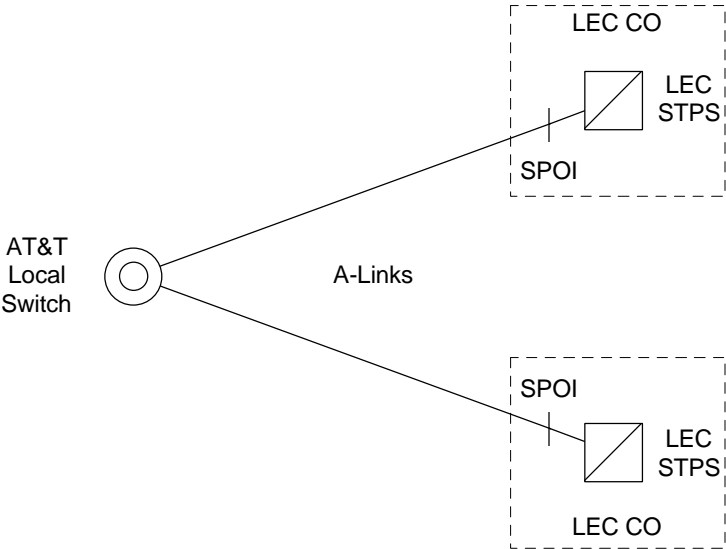

Figure 5. A-Link Interface

13.5.3.2.2. A D-link layer shall consist of four links, as depicted in Figure 6.

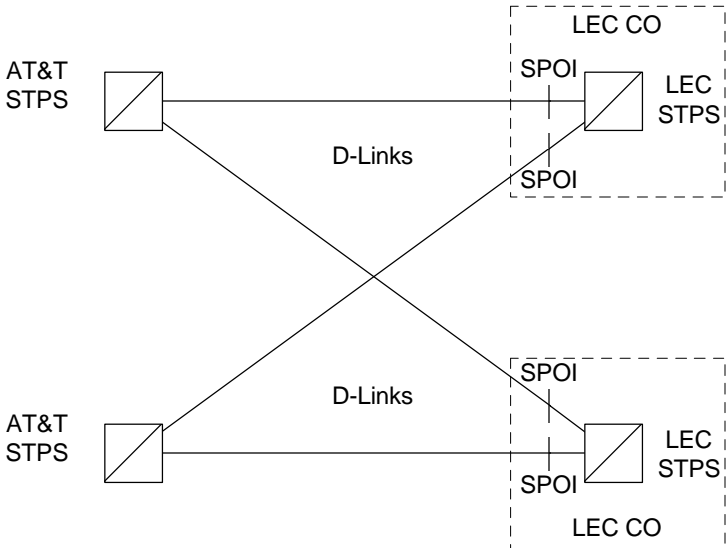

Figure 6. D-Link Interface

- 13.5.3.3. The Signaling Point of Interconnection (SPOI) for each link shall be located at a cross-connect element, (e.g., a DCS, DSX-1, etc.), in the Central Office (CO) where the GTE STPs are located. There shall be a 56kbps or higher rate transport interface at each of the SPOIs located in a GTE CO. Each signaling link shall appear as a DS0 channel within the DS1 or higher rate interface. GTE shall offer higher rate DS1 signaling links for interconnecting AT&T local switching systems or STPs with GTE STPs as soon as these become approved ANSI standards and available capabilities of GTE STPs.
- 13.5.3.4. To the extent GTE provides such capability to itself, its Affiliates or its subsidiaries in the particular GTE office, GTE shall provide intraoffice diversity between the SPOIs and the GTE STPs in that office, so that no single failure of intraoffice facilities or equipment shall cause the failure of both D-links in a layer connecting to a GTE STP.
- 13.5.3.5. The protocol interfaces for SS7 Network Interconnection include the MTP, ISDNUP, SCCP, and TCAP. These protocol interfaces shall, subject to Section 23.19 of the General Terms and Conditions of this Agreement, conform to the specifications contained in the technical references listed in Appendix A to this Attachment 2, under paragraph 14.
- 13.5.3.6. SS7 Network Interconnection shall be provided to AT&T in accordance with the technical references listed in Appendix A to this Attachment 2, under paragraph 15.

14.	Unused Transmission Media
14.1.	Definitions:
14.1.1.	Unused Transmission Media is physical inter-office transmission media (e.g., optical fiber, from an LGX in one central office to another LGX in another central office, copper twisted pairs from the MDF of one central office to the MDF in another central office, coaxial cable) which has no lightwave or electronic transmission equipment terminated to such media to operationalize its transmission capabilities. This media may exist in aerial or underground structure or within a building.
14.1.2.	Dark Fiber, one type of unused transmission media, is unused strands of optical fiber. Dark Fiber also includes strands of optical fiber existing in aerial or underground structure which have lightwave repeater (regenerator or optical amplifier)

equipment interspliced to it at appropriate distances, but which has no line terminating elements terminated to such strands to operationalize its transmission capabilities

14.1.3. GTE is not responsible for the end-to-end performance in those applications where AT&T is utilizing unused transmission media.

14.2. Requirements

14.2.1. GTE shall make available, for lease by AT&T, its dark fiber in the feeder segment of GTE's loops and, when AT&T has collocation space in a GTE tandem or end office, in the dedicated interoffice transport segment of GTE's network, subject to the conditions and requirements set forth in sections 14.2.2 through 14.3.2.

14.2.1.1. AT&T will bear the cost of extending dark fiber in the feeder segment of GTE's network to AT&T end-user premises or AT&T's facility access locations within the loop access network.

14.2.2. GTE shall provide a Single Point of Contact (SPOC) for negotiating all Unused Transmission Media lease agreements.

14.2.3. AT&T may test the quality of the Unused Transmission Media to confirm its usability and performance specifications. AT&T may only test from its point of physical collocation, AT&T's end-user premises or AT&T's facility access locations at which AT&T has access to such unused Transmission Media. For virtual collocation applications, GTE will perform test(s) on the dark fiber as requested by AT&T and provide the results of the test(s) to AT&T, at AT&T's expense. Should such test results not meet AT&T specifications, GTE will only be obligated to perform those maintenance activities it would have performed for itself.

14.2.4. Upon receipt of a bona fide request, GTE shall provide to AT&T information regarding the location, availability of Unused Transmission Media within twenty (20) business days after receiving a request for a specific location from AT&T.

14.2.5. GTE shall make Unused Transmission Media available to AT&T within twenty (20) business days after it receives written confirmation from AT&T that the Unused Transmission Media previously deemed available by GTE is wanted for use by

AT&T at the price established by the Commission. If a written confirmation is not received from AT&T within thirty (30) business days after verification of availability, GTE may make such Unused Transmission Media available for its own use or, may make it available to another requesting party.

14.2.6. In leasing loop feeder dark fiber and dedicated interoffice dark fiber to AT&T, GTE will allocate its dark fiber capacity among requesting CLECs on a first-come, first-served basis and in a competitively neutral manner. GTE lease agreements for such fiber may provide that they are revocable upon twelve months' notice by GTE, provided that, in order to exercise its right of revocation, GTE must demonstrate that the subject fiber is needed to meet GTE's bandwidth requirements or the bandwidth requirements of another LSP. In addition, if GTE can demonstrate within a twelve month period after the date of a dark fiber lease that AT&T is using the leased capacity at a transmission level less than OC-12 (622.08 million bits per second), GTE may revoke the lease agreement. Whenever GTE revokes a dark fiber lease agreement under this section 14.2.6, it will provide AT&T a reasonable and sufficient alternative means of transporting the traffic.

14.2.7. GTE is not required to make available for lease by AT&T more than twenty-five percent (25%) of its Unused Transmission Media or dark fiber capacity in a particular feeder or dedicated interoffice transport segment.

14.3. Requirements Specific to Dark Fiber

14.3.1. **AT&T will provide sufficient fiber cable from their LGX located in their physical collocation space to allow GTE personnel to terminate the GTE LGX. Where AT&T is obtaining access to dark fiber through virtual collocation, AT&T will provide the appropriate electronic equipment to terminate the fiber and GTE will provide the cross connection of the fiber to AT&T's equipment at AT&T's expense.**

14.3.2. **In those applications where AT&T requests optical regenerators, such regeneration will be provided by GTE on a case by case basis with additional costs to be borne by AT&T. However, in all events, AT&T may provide its own optical regenerators within AT&T's physical/virtual collocation space.**

[Unused Transmission Media]

APPENDIX A

Introduction

To the extent sections contained in this Appendix set forth technical references, technical standards, technical requirements, and/or performance standards, GTE's obligation to comply with such references, requirements, and/or standards shall be subject to Section 23.19 of the General Terms and Conditions of this Agreement.

1. The Network Interface Device (NID) shall be provided to AT&T in accordance with the following technical references:
 - 1.1 Bellcore Technical Advisory TA-TSY-000120 "Customer Premises or Network Ground Wire";
 - 1.2 Bellcore Generic Requirement GR-49-CORE "Generic Requirements for Outdoor Telephone Network Interface Devices";
 - 1.3 Bellcore Technical Requirement TR-NWT-00239 "Indoor Telephone Network Interfaces";
 - 1.4 Bellcore Technical Requirement TR-NWT-000937 "Generic Requirements for Outdoor and Indoor Building Entrance"; and,
 - 1.5 Bellcore Technical Requirement TR-NWT-000133 "Generic Requirements for Network Inside Wiring."
2. The Loop shall be equal to or better than each of the applicable interface references set forth in the following technical references:
 - 2.1 Bellcore TR-NWT-000049, "Generic Requirements for Outdoor Telephone Network Interface Devices," Issued December 1, 1994;
 - 2.2 Bellcore TR-NWT-000057, "Functional Criteria for Digital Loop Carrier Systems," Issued January 2, 1993;
 - 2.3 Bellcore TR-NWT-000393, "Generic Requirements for ISDN Basic Access Digital Subscriber Lines";

- 2.4 Bellcore TR-NWT-000253, SONET Transport Systems: Common Criteria (A module of TSGR, FR-NWT-000440), Issue 2, December 1991;
- 2.5 AT&T Data Communications Technical Reference TR 62310, DS0 Digital Local Channel Description and Interface Specification, August 1993; Also Addendum 1 and Addendum 2; and
- 2.6 AT&T Technical Reference TR 62411, ACCUNET T1.5 Service Description and Interface Specification, December 1990; Addendum 1, March 1991; Addendum 2, October 1992.
- 2.7 AT&T Technical Reference TR 62421, ACCUNET Spectrum of Digital Services Description and Interface Specification, December 1989; Also TR 62421A Addendum 2, November 1992.
- 2.8 ANSI T1.106 - 1988, American National Standard for Telecommunications - Digital Hierarchy - Optical Interface Specifications (Single Mode).
- 2.9 ANSI T1.105 - 1995, American National Standard for Telecommunications - Synchronous Optical Network (SONET) - Basic Description including Multiplex Structure, Rates and Formats.
- 2.10 ANSI T1.102 - 1993, American National Standard for Telecommunications - Digital Hierarchy - Electrical Interfaces.
- 2.11 ANSI T1.403- 1989, American National Standard for Telecommunications - Carrier to Customer Installation, DS1 Metallic Interface Specification
- 2.12 Bellcore GR-253-CORE, Synchronous Optical Network Systems (SONET), Common Generic Criteria.
- 2.13 AT&T Technical Reference TR 54014, ACCUNET T45 Reserved Services - Service Description and Interface Specification, May 1992.
- 2.14 AT&T Technical Reference TR 54018, ACCUNET T155 Service Description and Interface Specification.
- 2.15 Bellcore TR-TSY-000008, Digital Interface Between the SLC 96 Digital Loop Carrier System and a Local Digital Switch, Issue 2, August 1987.

- 2.16 Bellcore TR-NWT-000303, Integrated Digital Loop Carrier System Generic Requirements, Objectives and Interface, Issue 2, December 1992; Rev.1, December 1993; Supplement 1, December 1993.
- 2.17 Bellcore TR-TSY-000673, Operations Systems Interface for an IDLC System, (LSSGR) FSD 20-02-2100, Issue 1, September 1989.
- 2.18 AT&T Technical Reference TR-62415 "Access Specifications for High Capacity DS1/DS3 Dedicated Digital Service";
- 2.19 Bellcore Technical Requirement TR-NWT-000499, Issue 5, December 1993, section 7 for DS1 interfaces.

- 3. Local Switching shall be equal to or better than the references for Local Switching set forth in Bellcore's Local Switching Systems General Requirements (FR-NWT-000064) and shall be offered in accordance with the following technical references:
 - 3.1 GR-1298-CORE, AIN Switching System Generic Requirements;
 - 3.2 GR-1299-CORE, AIN Switch-Service Control Point (SCP)/Adjunct Interface Generic Requirements;
 - 3.3 TR-NWT-001284, AIN 0.1 Switching System Generic Requirements;
 - 3.4 SR-NWT-002247, AIN Release 1 Update.

- 4. Interface to Loop References:
 - 4.1 Basic Rate Interface ISDN adhering to ANSI standards Q.931, Q.932 and appropriate Bellcore Technical Requirements;
 - 4.2 Primary Rate ISDN to PBX adhering to ANSI standards Q.931, Q.932 and appropriate Bellcore Technical Requirements;
 - 4.3 Loops adhering to Bellcore TR-NWT-08 and TR-NWT-303 specifications to interconnect Digital Loop Carriers.

5. Interface to Loop for ISDN References
 - 5.1 GTE shall provide the BRI U interface using 2 wire copper loops in accordance with TR-NWT-000393, January 1991, Generic Requirements for ISDN Basic Access Digital Subscriber Lines.
 - 5.2 GTE shall provide the BRI interface using Digital Subscriber Loops adhering to Bellcore TR-NWT-303 specifications to interconnect Digital Loop Carriers.
 - 5.3 GTE shall offer PSD interfaces adhering to the X.25, S.75 and S.75' ANSI and Bellcore requirements.

6. At a minimum, Common Transport shall be provided to AT&T in accordance with the following technical references (as applicable for the transport technology being used):
 - 6.1 ANSI T1.101-1994, American National Standard for Telecommunications - Synchronization Interface Standard Performance and Availability;
 - 6.2 ANSI T1.102-1993, American National Standard for Telecommunications - Digital Hierarchy - Electrical Interfaces;
 - 6.3 ANSI T1.102.01-199x, American National Standard for Telecommunications - Digital Hierarchy - VT1.5;
 - 6.4 ANSI T1.105-1995, American National Standard for Telecommunications - Synchronous Optical Network (SONET) - Basic Description including Multiplex Structure, Rates and Formats;
 - 6.5 ANSI T1.105.01-1995, American National Standard for Telecommunications - Synchronous Optical Network (SONET) - Automatic Protection Switching;
 - 6.6 ANSI T1.105.02-1995, American National Standard for Telecommunications - Synchronous Optical Network (SONET) - Payload Mappings;
 - 6.7 ANSI T1.105.03-1994, American National Standard for Telecommunications - Synchronous Optical Network (SONET) - Jitter at Network Interfaces;

- 6.8 ANSI T1.105.03a-1995, American National Standard for Telecommunications - Synchronous Optical Network (SONET): Jitter at Network Interfaces - DS1 Supplement;
- 6.9 ANSI T1.105.05-1994, American National Standard for Telecommunications - Synchronous Optical Network (SONET) - Tandem Connection;
- 6.10 ANSI T1.105.06-199x, American National Standard for Telecommunications - Synchronous Optical Network (SONET) - Physical Layer Specifications;
- 6.11 ANSI T1.105.07-199x, American National Standard for Telecommunications - Synchronous Optical Network (SONET) - Sub STS-1 Interface Rates and Formats;
- 6.12 ANSI T1.105.09-199x, American National Standard for Telecommunications - Synchronous Optical Network (SONET) - Network Element Timing and Synchronization;
- 6.13 ANSI T1.106-1988, American National Standard for Telecommunications - Digital Hierarchy - Optical Interface Specifications (Single Mode);
- 6.14 ANSI T1.107-1988, American National Standard for Telecommunications - Digital Hierarchy - Formats Specifications;
- 6.15 ANSI T1.107a-1990 - American National Standard for Telecommunications - Digital Hierarchy - Supplement to Formats Specifications (DS3 Format Applications);
- 6.16 ANSI T1.107b-1991 - American National Standard for Telecommunications - Digital Hierarchy - Supplement to Formats Specifications;
- 6.17 ANSI T1.117-1991, American National Standard for Telecommunications - Digital Hierarchy - Optical Interface Specifications (SONET) (Single Mode - Short Reach);
- 6.18 ITU Recommendation G.707, Network node interface for the synchronous digital hierarchy (SDH);
- 6.19 ITU Recommendation G.704, Synchronous frame structures used at 1544, 6312, 2048, 8488 and 44736 kbit/s hierarchical levels;

- 6.20 Bellcore FR-440 and TR-NWT-000499, Transport Systems Generic Requirements (TSGR): Common Requirements;
- 6.21 Bellcore GR-820-CORE, Generic Transmission Surveillance: DS1 & DS3 Performance;
- 6.22 Bellcore GR-253-CORE, Synchronous Optical Network Systems (SONET); Common Generic Criteria;
- 6.23 Bellcore TR-NWT 000507, Transmission, Section 7, Issue 5 (Bellcore, December 1993). (A module of LSSGR, FR-NWT-000064.);
- 6.24 Bellcore TR-INS-000342, High-Capacity Digital Special Access Service-Transmission Parameter Limits and Interface Combinations, Issue 1 February 1991;
- 6.25 Bellcore ST-TEC 000052, Telecommunications Transmission Engineering Textbook, Volume 2: Facilities, Third Edition, Issue I May 1989;
- 6.26 Bellcore ST-TEC-000051, Telecommunications Transmission Engineering Textbook Volume 1: Principles, Third Edition. Issue 1 August 1987;

- 7. At a minimum, Dedicated Transport shall be provided to AT&T in accordance with the following technical references:
 - 7.1 ANSI T1.105.04-1995, American National Standard for Telecommunications - Synchronous Optical Network (SONET) - Data Communication Channel Protocols and Architectures;
 - 7.2 ANSI T1.119-1994, American National Standard for Telecommunications - Synchronous Optical Network (SONET) - Operations, Administration, Maintenance, and Provisioning (OAM&P) Communications;
 - 7.3 ANSI T1.119.01-1995, American National Standard for Telecommunications - Synchronous Optical Network (SONET) - Operations, Administration, Maintenance, and Provisioning (OAM&P) Communications Protection Switching Fragment;
 - 7.4 ANSI T1.119.02-199x, American National Standard for Telecommunications - Synchronous Optical Network (SONET) -

Operations, Administration, Maintenance, and Provisioning (OAM&P) Communications Performance Monitoring Fragment;

- 7.5 ANSI T1.231-1993 -American National Standard for Telecommunications - Digital Hierarchy - Layer 1 In-Service Digital Transmission performance monitoring.
- 7.6 AT&T Technical Reference TR 54016, Requirements For Interfacing Digital Terminal Equipment To Services Employing The Extended Superframe Format, September 1989;
- 7.7 AT&T Technical Reference TR 62421 ACCUNET Spectrum of Digital Services Description And Interface Specification, December 1989 and all addenda;
- 7.8 AT&T Technical Reference TR 62310, DS0 Digital Local Channel Description And Interface Specification, August 1993 and all addenda; and
- 7.9 AT&T Technical Reference TR 62415, Access Specification For High Capacity (DS1/DS3) Dedicated Digital Service, June 1989 and all addenda.
- 8. Digital Cross-Connect System (DCS) shall be provided to AT&T in accordance with the following technical references:
 - 8.1 AT&T Technical Reference TR 62421 ACCUNET® Spectrum of Digital Services Description And Interface Specification, December 1989 and TR 62421A Addendum 2, November 1992;
 - 8.2 AT&T Data Communications Technical Reference TR 62310 DS0 Digital Local Channel Description and Interface Specification, August 1993, and all addenda;
 - 8.3 AT&T Technical Reference TR 62415 Access Specification For High Capacity (DS1/DS3) Dedicated Digital Service, June 1989, and all addenda including TR 62415A3 July, 1992;
 - 8.4 AT&T Technical Reference TR 62411 ACCUNET® T1.5 Service Description And Interface Specification, December 1990 and all addenda including Addendum 2, October 1992;
 - 8.5 AT&T Technical Reference TR 54014 ACCUNET® T45 and T45 Reserved Services - Service Description And Interface Specification;

- 8.6 AT&T Technical Reference TR 54018 OC-3 Optical Interface Specifications, November 1991;
- 8.7 AT&T Technical Reference TR 54016 Requirements For Interfacing Digital Terminal Equipment To Services Employing The Extended Superframe Format, September 1989;
- 8.8 ANSI T1.102-1993, American National Standard for Telecommunications - Digital Hierarchy - Electrical Interfaces;
- 8.9 ANSI T1.102.01-199x, American National Standard for Telecommunications - Digital Hierarchy - VT1.5;
- 8.10 ANSI T1.105-1995, American National Standard for Telecommunications - Synchronous Optical Network (SONET) - Basic Description including Multiplex Structure, Rates and Formats;
- 8.11 ANSI T1.105.03-1994, American National Standard for Telecommunications - Synchronous Optical Network (SONET) - Jitter at Network Interfaces;
- 8.12 ANSI T1.105.03a-1995, American National Standard for Telecommunications - Synchronous Optical Network (SONET): Jitter at Network Interfaces - DS1 Supplement;
- 8.13 ANSI T1.105.06-199x, American National Standard for Telecommunications - Synchronous Optical Network (SONET) - Physical Layer Specifications;
- 8.14 ANSI T1.106-1988, American National Standard for Telecommunications - Digital Hierarchy - Optical Interface Specifications (Single Mode);
- 8.15 ANSI T1.107-1988, American National Standard for Telecommunications - Digital Hierarchy - Formats Specifications;
- 8.16 ANSI T1.107a-1990 - American National Standard for Telecommunications - Digital Hierarchy - Supplement to Formats Specifications (DS3 Format Applications);
- 8.17 ANSI T1.107b-1991 - American National Standard for Telecommunications - Digital Hierarchy - Supplement to Formats Specifications;

- 8.18 ANSI T1.117-1991, American National Standard for Telecommunications - Digital Hierarchy - Optical Interface Specifications (SONET) (Single Mode - Short Reach);
 - 8.19 ANSI T1.403-1989, Carrier to Customer Installation, DS1 Metallic Interface Specification;
 - 8.20 ANSI T1.404-1994, Network-to-Customer Installation - DS3 Metallic Interface Specification;
 - 8.21 ITU Recommendation G.707, Network node interface for the synchronous digital hierarchy (SDH);
 - 8.22 ITU Recommendation G.704, Synchronous frame structures used at 1544, 6312, 2048, 8488 and 44736 kbit/s hierarchical levels;
 - 8.23 FR-440 and TR-NWT-000499, Transport Systems Generic Requirements (TSGR): Common Requirements;
 - 8.24 GR-820-CORE, Generic Transmission Surveillance: DS1 & DS3 Performance;
 - 8.25 GR-253-CORE, Synchronous Optical Network Systems (SONET); Common Generic Criteria; and
 - 8.26 TR-NWT-000776, Network Interface Description for ISDN Customer Access.
9. Signaling Transfer Points (STPs) shall be provided to AT&T in accordance with the following technical references:
- 9.1 ANSI T1.111-1992 American National Standard for Telecommunications - Signaling System Number 7 (SS7) - Message Transfer Part (MTP);
 - 9.2 ANSI T1.111A-1994 American National Standard for Telecommunications - Signaling System Number 7 (SS7) - Message Transfer Part (MTP) Supplement;
 - 9.3 ANSI T1.112-1992 American National Standard for Telecommunications - Signaling System Number 7 (SS7) - Signaling Connection Control Part (SCCP);
 - 9.4 ANSI T1.115-1990 American National Standard for Telecommunications - Signaling System Number 7 (SS7) - Monitoring and Measurements for Networks;

- 9.5 ANSI T1.116-1990 American National Standard for Telecommunications - Signaling System Number 7 (SS7) - Operations, Maintenance and Administration Part (OMAP);
- 9.6 ANSI T1.118-1992 American National Standard for Telecommunications - Signaling System Number 7 (SS7) - Intermediate Signaling Network Identification (ISNI);
- 9.7 Bellcore GR-905-CORE, Common Channel Signaling Network Interface Specification (CCSNIS) Supporting Network Interconnection, Message Transfer Part (MTP), and Integrated Services Digital Network User Part (ISDNUP); and
- 9.8 Bellcore GR-1432-CORE, CCS Network Interface Specification (CCSNIS) Supporting Signaling Connection Control Part (SCCP) and Transaction Capabilities Application Part (TCAP).
- 10. SCPs/Databases shall be equal to or better than all of the references for SCPs/Databases set forth in the following technical references:
 - 10.1 GR-246-CORE, Bell Communications Research Specification of Signaling System Number 7, ISSUE 1 (Bellcore, December 1995);
 - 10.2 GR-1432-CORE, CCS Network Interface Specification (CCSNIS) Supporting Signaling Connection Control Part (SCCP) and Transaction Capabilities Application Part (TCAP). (Bellcore, March 1994);
 - 10.3 GR-954-CORE, CCS Network Interface Specification (CCSNIS) Supporting Line Information Database (LIDB) Service 6, Issue 1, Rev. 1 (Bellcore, October 1995);
 - 10.4 GR-1149-CORE, OSSGR Section 10: System Interfaces, Issue 1 (Bellcore, October 1995) (Replaces TR-NWT-001149);
 - 10.5 GR-1158-CORE, OSSGR Section 22.3: Line Information Database 6, Issue (Bellcore, October 1995)
 - 10.6 GR-1428-CORE, CCS Network Interface Specification (CCSNIS) Supporting Toll Free Service (Bellcore, May 1995); and
 - 10.7 BOC Notes on the RLEC Networks, SR-TSV-002275, ISSUE 2, (Bellcore, April 1994).

11. Signaling Transfer Points (STPs) shall offer SS7 AIN Access in accordance with the references of the following technical references:
 - 11.1 GR-2863-CORE, CCS Network Interface Specification Supporting Advanced Intelligent Network (AIN);
 - 11.2 GR-2902-CORE, CCS Network Interface Specification (CCSNIS) Supporting Toll-Free Service Using Advanced Intelligent Network (AIN).

12. Tandem Switching shall meet or exceed the following technical references:
 - 12.1 Bell Communications Research TR-TSY-000540 issue 2R2, Tandem Supplement, 6/1/90.
 - 12.2 GR-905-CORE covering CCSNIS;
 - 12.3 GR-1429-CORE for call management features; and GR-2863-CORE and GR-2902-CORE covering CCS AIN interconnection.

13. GTE performance under Section 13 of Attachment 2 shall meet or exceed the performance standards and references set forth in the technical references listed below;
 - 13.1 Bell Communications Research, Inc. Documents
 - 13.1.1 FR-64, LATA Switching Systems Generic Requirements (LSSGR). This document contains 117 Technical References and Generic Requirements. Sections provide the requirements for local switching systems (also referred to as end offices) that serve customers' lines. Some modules of the LSSGR are also referenced separately in this document.
 - 13.1.2 TR-NWT-000499, Issue 5, Rev 1, April 1992, Transport Systems Generic Requirements (TSGR): Common Requirements.
 - 13.1.3 TR-NWT-000418, Issue 2, December 1992, Generic Reliability Assurance Requirements For Fiber Optic Transport Systems.
 - 13.1.4 TR-NWT-000057, Issue 2, January 1993, Functional Criteria for Digital Loop Carriers Systems.

- 13.1.5 TR-NWT-000507, Issue 5, December 1993, LSSGR - Transmission, Section 7.
- 13.1.6 GR-303-CORE, Issue 1, September 1995, Integrated Digital Loop Carrier System Generic Requirements, Objectives, and Interface.
- 13.1.7 GR-334-CORE, Issue 1, June 1994, Switched Access Service: Transmission Parameter Limits and Interface Combinations.
- 13.1.8 TR-NWT-000335, Issue 3, May 1993, Voice Grade Special Access Services - Transmission Parameter Limits and Interface Combinations.
- 13.1.9 TR-TSY-000529, Issue 2, July 1987, Public Safety - LSSGR.
- 13.1.10 GR-1158-CORE, Issue 2, October 1995, OSSGR Section 22.3: Line Information Database.
- 13.1.11 TR-TSY-000511, Issue 2, July 1987, Service Standards, a Module (Section 11) of LATA Switching Systems Generic Requirements (LSSGR, FR-NWT-000064).
- 13.1.12 TR-NWT-000393, January 1991, Generic Requirements for ISDN Basic Access Digital Subscriber Lines.
- 13.1.13 TR-NWT-000909, December 1991, Generic Requirements and Objectives for Fiber In The Loop Systems.
- 13.1.14 TR-NWT-000505, Issue 3 , May 1991, LSSGR Section 5, Call Processing.
- 13.1.15 FR-NWT-000271, 1993, Operator Services Systems Generic Requirements (OSSGR).
- 13.1.16 TR-NWT-001156, Issue 2, July 1993, OSSGR Operator Services Systems Generic Requirements, Section 21, Operator Subsystem.
- 13.1.17 SR-TSY-001171, Issue 1, January 1989, Methods and Procedures for System Reliability Analysis.
- 13.1.18 Bellcore Telecommunications Transmission Engineering, 3rd Ed, 1990.
- 13.2 ANSI Standards

- 13.2.1 ANSI T1.512-1994, Network Performance - Point-to-Point Voice-Grade Special Access Network Voiceband Data Transmission Objectives.
- 13.2.2 ANSI T1.506-1990, Network Performance - Transmission Specifications for Switched Exchange Access Network.
- 13.2.3 ANSI T1.508-1992, Telecommunications - Network Performance - Loss Plan for Evolving Digital Networks. Also supplement T1.508a-1993.
- 13.2.4 ANSI T1.101-1994, Digital Synchronization Network Plan.
- 13.3 TIA/EIA Standards
 - 13.3.1 Requirements not specifically addressed here shall be found in the documents listed in Electronic Industries Association/Telecommunications Industries Association Standards and Engineering Publications.
 - 13.3.2 TIA/EIA TSB-37A, Telephone Network Transmission Model for Evaluating Modem Performance.
 - 13.3.3 TIA/EIA TSB-38, Test Procedure for Evaluation of 2-wire 4 kHz Voiceband Duplex Modems.
- 13.4 IEEE Standards
 - 13.4.1 IEEE Standard 743-1984, IEEE Standard Methods and Equipment for Measuring Transmission Characteristics of Analog Voice Frequency Circuits.
 - 13.4.2 ANSI/IEEE Standard 820-1984, Telephone Loop Performance Characteristics.
- 13.5 AT&T Standards
 - 13.5.1 Outside Plant Engineering Handbook, August 1994.
 - 13.5.2 AT&T Pub. 60220, Issue 1, April 1991, 5ESS OSPS Interface Technical Specification for Domestic Toll And Assistance Applications.
 - 13.5.3 AT&T Technical Reference TR 43202, May 1985, AT&T Analog Voice Total and Coordinated Services.

- 13.5.4 AT&T Technical Reference TR 41458, April 1990, Special Access Connection to the AT&T Network.
- 13.5.5 AT&T Technical Reference TR 62415, June 1989, Access Specification For High Capacity (DS1/DS3) Dedicated Digital Service. Also TR 62415A2 November 1990, and TR 62415A3 July 1992 which are addenda to TR 62415.
- 13.5.6 AT&T Technical Reference TR 54016, September 1989, Requirements For Interfacing Digital Terminal Equipment To Services Employing The Extended Superframe Format.
- 13.5.7 AT&T Technical Reference TR 62411, December 1990, ACCUNET T1.5 Service Description And Interface Specification. Also Addendum 1 March 1991 and Addendum 2 October 1992.
- 13.5.8 AT&T Technical Reference TR 62421, December 1989, ACCUNET Spectrum of Digital Services Description And Interface Specification. Also TR 62421A Addendum 2 November 1992.
- 13.5.9 AT&T Data Communications Technical Reference TR 62310, August 1993, DS0 Digital Local Channel Description And Interface Specification. Also Addendum 2 November 1992.
- 13.5.10 AT&T Technical Reference TR 54014, 1992, ACCUNET T45 and T45 Reserved Services - Service Description And Interface Specification.
- 13.5.11 AT&T Technical Reference TR 54018, most current issue, ACCUNET T155 Service Description And Interface Specification.
- 14. The protocol interface references for SS7 Network Interconnection include the MTP, ISDNUP, SCCP, and TCAP. These protocol interfaces shall conform to the following specifications:
 - 14.1 Bellcore GR-905-CORE, Common Channel Signaling Network Interface Specification (CCSNIS) Supporting Network Interconnection, Message Transfer Part (MTP), and Integrated Services Digital Network User Part (ISDNUP);
 - 14.2 Bellcore GR-1428-CORE, CCS Network Interface Specification (CCSNIS) Supporting Toll Free Service;
 - 14.3 Bellcore GR-1429-CORE, CCS Network Interface Specification (CCSNIS) Supporting Call Management Services; and

- 14.4 Bellcore GR-1432-CORE, CCS Network Interface Specification (CCSNIS) Supporting Signaling Connection Control Part (SCCP) and Transaction Capabilities Application Part (TCAP).
- 14.5 GTE shall set message screening parameters to block accept messages from AT&T local or tandem switching systems destined to any signaling point in the GTE SS7 network with which the AT&T switching system has a legitimate signaling relation.
15. SS7 Network Interconnection shall be provided to AT&T in accordance with the following technical references:
- 15.1 ANSI T1.110-1992 American National Standard Telecommunications - Signaling System Number 7 (SS7) - General Information;
- 15.2 ANSI T1.111-1992 American National Standard for Telecommunications - Signaling System Number 7 (SS7) - Message Transfer Part (MTP);
- 15.3 ANSI T1.111A-1994 American National Standard for Telecommunications - Signaling System Number 7 (SS7) - Message Transfer Part (MTP) Supplement;
- 15.4 ANSI T1.112-1992 American National Standard for Telecommunications - Signaling System Number 7 (SS7) - Signaling Connection Control Part (SCCP);
- 15.5 ANSI T1.113-1995 American National Standard for Telecommunications - Signaling System Number 7 (SS7) - Integrated Services Digital Network (ISDN) User Part;
- 15.6 ANSI T1.114-1992 American National Standard for Telecommunications - Signaling System Number 7 (SS7) - Transaction Capabilities Application Part (TCAP);
- 15.7 ANSI T1.115-1990 American National Standard for Telecommunications - Signaling System Number 7 (SS7) - Monitoring and Measurements for Networks;
- 15.8 ANSI T1.116-1990 American National Standard for Telecommunications - Signaling System Number 7 (SS7) - Operations, Maintenance and Administration Part (OMAP);

- 15.9 ANSI T1.118-1992 American National Standard for Telecommunications - Signaling System Number 7 (SS7) - Intermediate Signaling Network Identification (ISNI);
- 15.10 Bellcore GR-905-CORE, Common Channel Signaling Network Interface Specification (CCSNIS) Supporting Network Interconnection, Message Transfer Part (MTP), and Integrated Services Digital Network User Part (ISDNUP);
- 15.11 Bellcore GR-954-CORE, CCS Network Interface Specification (CCSNIS) Supporting Line Information Database (LIDB) Service;
- 15.12 Bellcore GR-1428-CORE, CCS Network Interface Specification (CCSNIS) Supporting Toll Free Service;
- 15.13 Bellcore GR-1429-CORE, CCS Network Interface Specification (CCSNIS) Supporting Call Management Services; and,
- 15.14 Bellcore GR-1432-CORE, CCS Network Interface Specification (CCSNIS) Supporting Signaling Connection Control Part (SCCP) and Transaction Capabilities Application Part (TCAP).

ATTACHMENT 3

SERVICE DESCRIPTION: ANCILLARY FUNCTIONS

TABLE OF CONTENTS

<u>Section</u>	<u>Page</u>
SERVICE DESCRIPTION: ANCILLARY FUNCTIONS.....	1
1. Introduction.....	1
2. Collocation.....	1
3. Poles, Ducts, Conduits, Rights of Way (ROW)	9

SERVICE DESCRIPTION: ANCILLARY FUNCTIONS

1. **Introduction**

This Attachment sets forth the descriptions and requirements for Ancillary Functions that GTE agrees to offer to AT&T under this Agreement. To the extent sections contained in this Appendix set forth technical references, technical standards, technical requirements, and/or performance standards, GTE's obligation to comply with such references, requirements, and/or standards shall be subject to Section 23.19 of the General Terms and Conditions of this Agreement.

2. **Collocation**

2.1 Definition: Collocation is the right of AT&T to obtain dedicated space in GTE's Local Serving Office (LSO) or other GTE locations and to place equipment in such spaces to interconnect with the GTE network or obtain access to unbundled network elements. Collocation also includes GTE providing resources necessary for the operation and economical use of collocated equipment.

2.1.1 Terms: Collocation shall be provided in accordance with this Agreement as supplemented by the applicable GTE federal and state collocation tariffs in effect as of the effective date of this Agreement. To the extent any matter relating to collocation is not already addressed in the terms of the Agreement, the terms of the tariffs will control.

2.2 Technical References

2.2.1 Upon request by AT&T, GTE shall provide space, as required by 47 CFR § 51.323 and as requested by AT&T, to meet AT&T's needs for placement of equipment, interconnection, or provision of services. Such space shall be provided in GTE's proposed central offices, serving wire center and tandem switches, as well as all buildings or similar structures owned or leased by GTE, whether or not on public rights-of-way, that house GTE network facilities, including but not limited to vaults containing loop concentrators or similar structures, unless, for any specific facility, GTE is able to demonstrate that it is not physically feasible to accommodate AT&T's request, after taking into account specific, detailed plans GTE has for the use of the space. GTE will provide collocation as follows: physical collocation will be provided on a first-come, first-served basis, provided there is space available for collocation and provided there are reasonable security arrangements. If GTE determines that space is not available GTE shall provide virtual collocation for AT&T equipment, unless GTE

demonstrates that virtual collocation is not available under currently Applicable Law. GTE and AT&T shall adhere to reasonable industry standard security measures, applied on a non-discriminatory basis.

- 2.2.1.1 GTE may reserve collocation space for its own use on terms and conditions that do not favor GTE over other carriers seeking to hold collocation space for their own future use. AT&T will pay for any space reserved for future use in accordance with such non-discriminatory terms for reserving collocation space and in accordance with the pricing terms of Attachment 14 and future order of the Commission.
- 2.2.1.2 GTE is not required to construct additional space when none is available to meet a physical collocation request. However, in determining whether space is available to meet a request for physical collocation, GTE will offer contiguous space to AT&T where available. GTE will also take AT&T and other collocater demand into account when renovating existing facilities and constructing or leasing new facilities.
- 2.2.2 GTE shall provide intraoffice facilities (e.g., DS0, DS1, DS3, OC3, OC12, OC48, and STS-1 terminations) as requested by AT&T to meet AT&T's need for placement of equipment, interconnection, or provision of service.
- 2.2.3 Other than reasonable security restrictions, where AT&T's physical collocated space is located in space that is partitioned separately from GTE facilities, GTE shall place no restriction on access to the AT&T collocated space by AT&T's employees and designated agents. Such space shall be available to AT&T designated agents twenty-four (24) hours per day each day of the week. Where AT&T's collocated space is located in space that is not partitioned separately from GTE's facilities, GTE shall provide AT&T designated personnel escort service to and from AT&T's collocated space. Such escort service shall be available twenty-four (24) hours per day each day of the week. In no case should any reasonable security restrictions be more restrictive than those GTE places on their own personnel.
- 2.2.4 GTE will not place any restrictions on AT&T's use of its collocated space, other than limitations specified in this Agreement or limitations based on space availability and reasonable security requirements, applied in a nondiscriminatory manner. AT&T may collocate the amount and type of equipment in its collocated space that is necessary for interconnection functions (which include interconnection with GTE's network and other collocated carriers or access to GTE's unbundled network elements), including but not limited to transmission equipment,

multiplexing equipment and remote switching modules; provided however that AT&T may not collocate enhanced services equipment; and provided further that AT&T may locate remote switching modules in its collocated space only in the instances in which the technical architecture of GTE's network does not allow AT&T's system to terminate on GTE's system without a degradation of customer service.

- 2.2.5 GTE shall allow the interconnection of AT&T to other carriers who have collocated space within GTE's facility (e.g., GTE shall not require AT&T to interconnect with other carriers outside of GTE's facilities). This connection will be provisioned using EISCC (expanded interconnection service cross connect jumper) and will be priced as set forth in Attachment 14.
- 2.2.6 AT&T may select its own vendors for all required engineering and installation services associated with its physically collocated equipment subject to GTE's reasonable restrictions on third party vendors that GTE has decertified with good cause. GTE shall maintain and provide AT&T with a list of all such decertified vendors. Notwithstanding GTE decertification of a third party vendor, AT&T may use such vendor for work associated with its collocated equipment if such vendor is the only third party vendor reasonably available to AT&T to perform such work. In no event shall GTE require AT&T to utilize GTE's internal engineering or installation work forces for the engineering and installation of AT&T's physically collocated equipment.
- 2.2.7 GTE shall provide basic telephone service with a connection jack as requested by AT&T from GTE for the collocated space. Upon AT&T's request, this service shall be available at the AT&T collocated space on the day that the space is turned over to AT&T by GTE.
- 2.2.8 GTE shall provide adequate lighting, ventilation, power, heat, air conditioning, and other environmental conditions for AT&T's space and equipment. These environmental conditions shall, subject to Section 23.19 of the General Terms and Conditions of this Agreement, adhere to Bell Communication Research (Bellcore) Network Equipment-Building System (NEBS) standards TR-EOP-000063.
- 2.2.9 [This section intentionally deleted.]
- 2.2.10 GTE shall provide all ingress and egress of fiber and power cabling to AT&T collocated spaces in compliance with AT&T's cable diversity standards to the extent such standards do not exceed GTE's cable diversity standards or the level of diversity it provides to itself. The specific level of diversity required for each site or Network Element will

be provided in the collocation request. If AT&T's requirements exceed the level of diversity which GTE provides to itself in such site or to such Network Element, GTE shall at its sole discretion decide whether to provide such superior diversity. If GTE agrees to provide such superior diversity, AT&T will pay for the provision of the diversity. In such event the price will be established on an individual case basis in accordance with the applicable GTE intrastate access tariff. AT&T will also pay for the provision of such diversity in circumstances where AT&T's requirements do not exceed those provided by GTE for itself in such site or to such Network Element, but where capacity does not exist in the fiber or power cabling to accommodate the provision of diversity requested by AT&T. In such circumstances, the price will be established on an individual case basis in accordance with the applicable GTE intrastate access tariff.

- 2.2.11 This Section 2.2.11 left intentionally blank.
- 2.2.12 GTE shall adhere to the DMOQs, set forth in Attachment 12.
- 2.2.13 GTE will provide answers to AT&T's Environmental, Health & Safety Questionnaire at the first contact meeting for each collocated space in each building in which collocated space is provided.
- 2.2.14 GTE shall provide AT&T with written notice at least two (2) business days prior to those instances in which GTE or its subcontractors may be performing non-emergency work in the general area of the collocated space occupied by AT&T, or in the general area of the AC and DC power plants which support AT&T equipment that is, or potentially may be, service affecting. GTE will inform AT&T by telephone of any emergency related activity that GTE or its subcontractors may be performing in the general area of the collocated space occupied by AT&T, or in the general area of the AC and DC power plants which support AT&T equipment. GTE will use diligent efforts to notify AT&T of any emergency related activity prior to the start of the activity so that AT&T can take any action required to monitor or protect its service.
- 2.2.15 GTE shall construct the collocated space in compliance with AT&T's collocation requests for cable holes, ground bars, doors, and convenience outlets as long as such request is in compliance with Applicable Laws and GTE's grounding requirements. To the extent that such request involves additional work beyond that required to construct the standard GTE collocation space, the price for such construction will be on an individual case basis or as established in

accordance with Attachment 14. The standard collocation space shall be equipped with the following:

- 2.2.15.1 Four 8ft high, or such height as is appropriate for the specific space, 9 gauge chain link panels;
 - 2.2.15.2 One AC outlet;
 - 2.2.15.3 An electrical outlet sub-panel;
 - 2.2.15.4 Adequate lighting;
 - 2.2.15.5 Cage ground bar; and
 - 2.2.15.6 One padlock set.
- 2.2.16 AT&T and GTE will complete an acceptance walk through of all collocated space requested from GTE. Exceptions that are noted during this acceptance walk through shall be corrected by GTE within five (5) business days after the walk through. The correction of these exceptions from the original collocation request shall be at GTE's expense.
- 2.2.17 GTE shall provide Telephone Equipment detailed drawings depicting the exact location, type, and cable termination requirements (i.e., connector type, number and type of pairs, and naming convention) for GTE Point of Termination Bay(s) to AT&T at the first mutually scheduled GTE/AT&T collocation meeting with respect to the specific request which meeting shall occur within thirty five (35) days of AT&T's request for collocated space, except in unusual cases.
- 2.2.18 GTE shall provide Telephone Equipment detailed drawings depicting the exact path, with dimensions, for AT&T Outside Plant Fiber ingress and egress into AT&T collocated space at the first mutually scheduled collocation meeting which meeting shall occur within thirty five (35) days of AT&T's request for collocated space, except in unusual cases. Such path and any areas around it in which AT&T must work to perform installation shall be free of friable asbestos, lead paint (unless encapsulated), radon and other health or safety hazards.
- 2.2.19 GTE shall provide detailed power cabling connectivity information including the sizes and number of power feeders to AT&T no later than five (5) days in advance of the first mutually scheduled collocation meeting.

- 2.2.20 GTE shall provide positive confirmation to AT&T when construction of AT&T collocated space is approximately 50% completed. This confirmation shall also include confirmation of the scheduled completion and turnover dates.
- 2.2.21 GTE will make every reasonable effort to meet the negotiated completion and turnover dates, which dates shall be no greater than 120 days from the original collocation request, except in unusual cases or in instances where GTE is precluded from meeting such dates because of delay caused by the need to obtain building permits, despite the use of every reasonable effort by GTE to obtain such permits in time to meet the negotiated dates.
- 2.2.22 GTE shall provide the following information to AT&T no later than five (5) business days in advance of the first mutually scheduled collocation meeting:
- 2.2.22.1 Work restriction guidelines.
- 2.2.22.2 GTE or Industry technical publication guidelines that impact the design of AT&T collocated equipment.
- 2.2.22.3 GTE contacts (names and telephone numbers) for the following areas:
Engineering
Physical & Logical Security
Provisioning
Billing
Operations
Site and Building Managers
Environmental and Safety
- 2.2.22.4 Escalation process for GTE representatives (names, telephone numbers and the escalation order) for any disputes or problems that might arise pursuant to AT&T's collocation.
- 2.2.23 Power as referenced in this Attachment 3 refers to any electrical power source supplied by GTE for AT&T equipment. It includes all superstructure, infrastructure, and overhead facilities, including, but not limited to, cable, cable racks and bus bars. GTE will supply power to support AT&T equipment at equipment specific DC and AC voltages. At a minimum, GTE shall supply power to AT&T at parity with that provided by GTE to itself for similar equipment.
- 2.2.23.1 Central office power supplied by GTE into the AT&T equipment area, shall be supplied in the form of power feeders (cables) on cable

racking into the designated AT&T equipment area. The power feeders (cables) shall perform in a manner equal to the efficiency and economy of the power feeders (cables) GTE provides for use with similar GTE equipment. The termination location shall be mutually agreed upon by the Parties.

- 2.2.23.2 [Intentionally deleted.]
- 2.2.23.3 GTE power equipment supporting AT&T's equipment shall, subject to Section 23.19 of the General Terms and Conditions of this Agreement:
 - 2.2.23.3.1 Comply with applicable industry standards (e.g., Bellcore, NEBS and IEEE) or manufacturer's equipment power requirement specifications for equipment installation, cabling practices, and physical equipment layout;
 - 2.2.23.3.2 Have redundant DC power through battery back-up as required by the equipment manufacturer's specifications for AT&T equipment, or, at minimum, at parity with that provided for similar GTE equipment;
 - 2.2.23.3.3 GTE shall immediately notify AT&T if an alarm condition exists with respect to such monitoring or if backup power has been engaged for any power supporting AT&T's equipment;
- 2.2.23.4 Provide central office ground, in accordance with GTE's grounding requirements; and
- 2.2.23.5 Provide power feeder capacity and quantity to support the equipment layout for AT&T equipment in accordance with AT&T's collocation request and in accordance with Section 2.2.23.1 of this Attachment 3.
- 2.2.23.6 GTE shall, subject to Section 23.19 of the General Terms and Conditions of this Agreement:
 - 2.2.23.6.1 Provide installation sequences and access that will allow installation efforts in parallel without jeopardizing personnel safety or existing AT&T services;
 - 2.2.23.6.2 Provide power plant alarms that adhere to Bell Communication Research (Bellcore) Network Equipment-Building System (NEBS) standards TR-EOP-000063;
 - 2.2.23.6.3 Provide cabling that adheres to Bell Communication Research (Bellcore) Network Equipment-Building System (NEBS) standards TR-EOP-000063;

- 2.2.23.6.4 Provide Lock-Out Tag Out and other electrical safety procedures and devices in accordance with OSHA or industry guidelines.
- 2.2.23.7 GTE will provide AT&T with written notification within ten (10) business days of any scheduled non-emergency AC or DC power work or related activity in the collocated facility that will or might cause an outage or any type of power disruption to AT&T equipment located in the GTE facility. GTE will use diligent efforts to notify AT&T by telephone of any emergency power activity that would impact AT&T equipment.
- 2.2.23.8 With respect to any work to provide or prepare collocation space (including, without limitation, power supplies and cage construction) proposed to be performed by GTE or its subcontractors or vendors on behalf of AT&T:
- 2.2.23.8.1 GTE shall, within thirty (30) days after a request by AT&T, provide AT&T with a written price for any such work. The price will be accompanied by the following written information: (a) any terms under which the work is proposed to be performed, (b) a reasonably detailed breakdown or explanation of costs underlying the price, and (c) a reasonably detailed description of the technical specifications of the work to be performed. AT&T must approve the price, terms, cost breakdown and technical specifications prior to any work being performed.
- 2.2.23.8.2 Following completion of the work, AT&T and GTE will complete an acceptance walk through of the collocated space in accordance with Section 2.2.16.
- 2.2.24 GTE shall be required to take AT&T demand for collocation space into account when expanding, adding to or altering existing facilities and constructing or leasing new facilities.
- 2.3 Technical References - GTE shall, subject to Section 23.19 of the General Terms and Conditions of this Agreement, provide collocation in accordance with the following standards:
- 2.3.1 Institute of Electrical and Electronics Engineers (IEEE) Standard 383, IEEE Standard for Type Test of Class 1 E Electric Cables, Field Splices, and Connections for Nuclear Power Generating Stations.
- 2.3.2 National Electrical Code (NEC) use latest issue.
- 2.3.3 TA-NPL-000286, NEBS Generic Engineering Requirements for System Assembly and Cable Distribution, Issue 2, (Bellcore, January 1989).

- 2.3.4 TR-EOP-000063 Network Equipment-Building System (NEBS) Generic Equipment Requirements, Issue 3, March 1988.
- 2.3.5 TR-EOP-000151, Generic Requirements for 24-, 48-, 130-, and 140-Volt Central Office Power Plant Rectifiers, Issue 1, (Bellcore, May 1985).
- 2.3.6 TR-EOP-000232, Generic Requirements for Lead-Acid Storage Batteries, Issue 1 (Bellcore, June 1985).
- 2.3.7 TR-NWT-000154, Generic Requirements for 24-, 48-, 130, and 140-Volt Central Office Power Plant Control and Distribution Equipment, Issue 2, (Bellcore, January 1992).
- 2.3.8 TR-NWT-000295, Isolated Ground Planes: Definition and Application to Telephone Central Offices, Issue 2, (Bellcore, July 1992).
- 2.3.9 TR-NWT-000840, Supplier Support Generic Requirements (SSGR), (A Module of LSSGR, FR-NWT-000064), Issue 1, (Bellcore, December 1991).
- 2.3.10 TR-NWT-001275 Central Office Environment Installations/Removal Generic Requirements, Issue 1, January 1993.
- 2.3.11 Underwriters' Laboratories Standard, UL 94.

3. **Poles, Ducts, Conduits, Rights of Way (ROW)**

3.1 **Definitions**

- 3.1.1 An "Attachment" is any placement of AT&T's Facilities in or on GTE's poles, ducts, conduits, or rights of way.
- 3.1.2 A "conduit" is a tube or protected trough that may be used to house communication or electrical cables. Conduit may be underground or above ground and may contain one or more inner ducts.
- 3.1.3 A "duct" is a single enclosed path to house facilities to provide telecommunications services.
- 3.1.4 For the purpose of this Section 3, the terms "Facility" and "Facilities" include anchors, pole hardware, wires, cables, strands, apparatus enclosures, equipment boxes, optical conductors and associated hardware and other telecommunications equipment located on or in a Structure.

- 3.1.4.1 For purposes of this Section 3, the terms "Structure" and "Structures" refer to poles, ducts, conduits and ROW and, to the extent owned or controlled by GTE, other real estate that is used, planned to be used, or suitable for use by GTE, for GTE's distribution facilities.
- 3.1.5 An "inner duct" is one of the single enclosed pathways located within a duct, or buried separately without the benefit of conduit.
- 3.1.6 The term "make ready work" refers to all work performed or to be performed to prepare GTE's conduit systems, poles or anchors and related facilities for the requested occupancy or attachment of AT&T's Facilities. "Make ready work" includes, but is not limited to, clearing obstructions, the rearrangement, transfer, replacement, and removal of existing Facilities on a pole or in a conduit system where such work is required solely to accommodate AT&T's Facilities and not to meet GTE's business needs or convenience. "Make ready work" may include the repair, enlargement, or modification of GTE's Structures (including, but not limited to, conduits, ducts, or manholes) or the performance of other work required to make a pole, anchor, conduit or duct usable for the initial placement of AT&T's Facilities.
- 3.1.7 A "manhole" is a subsurface enclosure that personnel may enter and use for the purpose of installing, operating, maintaining and repairing communications Facilities.
- 3.1.8 A "pole attachment" is the connection of a Facility to a utility pole.
- 3.1.9 A "Right of Way" ("ROW") is the right to use the land or other property of another party to place poles, conduits, cables, other structures and equipment, or to provide passage to access such structures and equipment. A ROW may run under, on, or above public or private property (including air space above public or private property) and may include the right to use discrete space in buildings, building complexes, or other locations. The existence of a ROW shall be determined in accordance with Applicable Law.

3.2 **General Duties**

- 3.2.1 GTE hereby grants to AT&T and AT&T accepts from GTE a non-exclusive license to occupy, place and maintain in or on specified GTE poles, ducts, conduits and ROW, AT&T's Attachments and Facilities on the terms and conditions set forth in this Attachment 3. AT&T shall have no further right, title, or other interest in connection with GTE's poles, ducts, conduits and ROW. GTE shall have the right to grant, renew or extend privileges to others not parties to this Agreement to

occupy, place, or maintain Attachments on or otherwise use any or all GTE poles, ducts, conduits and ROW. GTE grants this license in reliance on the representation of AT&T that AT&T intends to provide Telecommunications Services.

- 3.2.2 GTE shall provide AT&T equal and non-discriminatory access to pole space, ducts, inner ducts, conduit, and ROW, and other real estate owned or controlled by GTE that is used, planned to be used, or suitable for use by GTE, for GTE's distribution facilities. Such access shall be provided to AT&T on terms and conditions as favorable as is provided by GTE to any other CLEC. Further, GTE shall not preclude or delay allocation of these Structures to AT&T because of the potential needs of itself or of other parties, except as provided below. This general duty is subject to any agreements or easements that would prohibit GTE from providing such access on specific pole space, ducts, conduit, or ROW to AT&T. If GTE determines that access to specific pole space, ducts, conduit, or ROW is precluded by an agreement or easement, AT&T shall have the right to review the pertinent provisions of the agreement or easement.
- 3.2.3 GTE will not enter into any agreements with owners that restrict the ability of the owner to reach agreements with AT&T regarding access to ROW or other real estate to which AT&T is entitled access pursuant to Section 3.2.2 of this Attachment 3.
- 3.2.4 GTE shall provide to AT&T a Regional Single Point of Contact to resolve issues that arise in the implementation of this Agreement.
- 3.2.5 Excepting maintenance and emergency ducts as provided below, all useable but unused space on poles, conduits, ducts or ROW owned or controlled by GTE shall be available for the attachments of AT&T, GTE or other providers of Telecommunications Services or cable television systems; provided, however, GTE may exclude or condition access for reasons of safety, reliability and generally applicable engineering standards, provided that such exclusions and conditions are consistent with those that GTE applies to its own use of poles, ducts, conduits and ROW. GTE may reserve capacity on poles, conduits, ducts and ROW for GTE's future use if the amount it reserves is reasonable under the circumstances. GTE's treatment of spare capacity shall be consistent with its obligation to provide uniform, nondiscriminatory access to all providers. AT&T shall have an equivalent opportunity to procure spare capacity and reserve such capacity for its own future use. GTE's reservation of space shall be presumptively reasonable if GTE allocates spare capacity on the basis of 25% for its own use and 75% for the use of competing providers. GTE may also reserve for

emergency and maintenance purposes one duct in each conduit section of its facility routes. Such duct shall be equally accessible and available by any party with Facilities in such conduit section to use to maintain its Facilities or to restore them in an emergency. Reservation of duct space for emergency and maintenance purposes shall not constitute reservation of capacity for GTE's future use and shall not be considered in any determination of reasonableness of GTE's reservation of spare capacity for future use by GTE.

3.3 **Pre-Ordering Disclosure Requirements**

- 3.3.1 AT&T may request information regarding the availability and conditions of poles, ducts, conduits, and ROW prior to the submission of Attachment Requests. GTE shall provide information regarding the availability and condition of GTE's poles, ducts, conduits, or ROW for Attachments within thirty (30) business days. If it is unable to inform AT&T about availability and conditions within the thirty-day interval, GTE shall advise AT&T within ten (10) days after receipt of AT&T's information request and will seek a mutually satisfactory time period for GTE's response. If GTE's response requires a field-based survey, AT&T shall have the option to be present at the field-based survey and GTE shall provide AT&T at least twenty-four (24) hours notice prior to the start of such field survey. During and after this period, GTE shall allow AT&T personnel to enter manholes and view pole structures to inspect such structures in order to confirm usability or assess the condition of the structure.
- 3.3.2 GTE shall make available to AT&T for inspection marked street maps and as-built drawings showing existing poles, conduit or other ROW at GTE's area engineering offices, upon reasonable advance notification. If the Parties can ascertain the availability of a specific point-to-point route at the time of viewing, GTE will make the maps and pole prints available for copying. In making these maps and prints available, GTE makes no express or implied warranty as to the accuracy of these maps and prints, other than to represent that they are the maps and prints GTE uses in its day-to-day operations. GTE reserves the right to deny subsequent requests to see previously viewed maps and prints if AT&T does not have a good faith intention to submit an Attachment Request relating to the areas described.
- 3.3.3 AT&T shall pay GTE a reasonable administrative fee to cover the direct cost of providing conduit maps and prints.

3.4 **Attachment Requests**

- 3.4.1 GTE agrees to permit AT&T to place AT&T's Facilities on or in GTE's poles, ducts, conduits, and ROW pursuant to Attachment Requests from AT&T approved in accordance with this Section 3.4 on the terms and conditions set forth herein. GTE may not restrict AT&T's ability to construct, maintain and monitor its facilities at these sites to any greater extent than GTE restricts its own ability to construct, maintain and monitor the same facilities.
- 3.4.2 For access to GTE owned or controlled poles, AT&T will follow this process: (a) AT&T forwards a completed pole attachment inquiry/request form to GTE; (b) GTE reviews inquiry/request form and verifies the availability of space and communicates availability information back to AT&T within 30 business days; (c) AT&T decides whether it wants space; (d) If AT&T wants space, it will provide three (3) copies of maps, pole lease application and permit, permit compliance letter, rearrangement worksheet ("make ready" sheet); (e) AT&T will provide a check to cover the costs of GTE inspection and the first year's rent pro-rated to the next (annual) billing period. At this point, AT&T is guaranteed space and GTE opens a work order; (f) GTE uses make ready sheets to inspect the poles for proper build and identification of possible infractions. This process could take up to 45 days depending upon the size of the job; (g) GTE provides to AT&T a corrected copy of the make ready sheets and gives AT&T permission to start its build; (h) AT&T has 60 to 90 days to begin construction, but can start construction immediately upon receiving permission; (i) After construction is complete AT&T will notify GTE. GTE will complete a final inspection and identify infractions on a "gig" sheet provided back to AT&T. AT&T has 30 days to fix infractions; and (j) AT&T will notify GTE when work is complete and GTE will do one last inspection and close work order.
- 3.4.3 For access to GTE owned or controlled ducts or conduit, AT&T will follow this process: (a) AT&T forwards a completed conduit/duct occupancy inquiry/request form to GTE; (b) GTE reviews inquiry/request form for availability, but not integrity of conduit/duct and communicates availability information back to AT&T within 30 business days; (c) AT&T decides whether it wants conduit/duct, and if so requests to know the integrity of the conduit/duct. Prior to integrity verification, GTE will require either an engineering deposit or an escrow account for the inspector's or single source provider's (SSP) time; (d) Upon receipt of the deposit or escrow funds, AT&T can request GTE (SSP) to pull a slug through the duct to validate integrity. If and when requested, GTE will do so and will also attach a mule tape

to the back end of the slug to get an accurate read (footage) from point A to point B of the conduit/duct. Alternatively, AT&T can have its approved vendor pull a slug with GTE's inspector watching; (e) Once the integrity of the conduit/duct is validated, AT&T will provide a check for the first year's rental associated with the amount of the actual footage to be leased pro-rated to the next (annual) billing period and an engineering design within 30 business days, which will provide procedures for access to the conduit/duct including, but not limited to a gas test procedure, a procedure for dealing with water in manholes which are used to access the conduit/duct, and how AT&T will guard the other Facilities in the manhole during its work. At this point conduit/duct is guaranteed to AT&T; (f) AT&T will access the conduit/duct through a manhole, a cable equipment vault or another mutually agreed means; (g) AT&T will be given 60 to 90 days to start construction, but can start construction immediately, at the point conduit/duct is guaranteed to AT&T; (h) After construction is complete, AT&T will notify GTE; and (i) GTE will complete a visual inspection of the job as well as any inspections during construction that GTE deems are necessary.

- 3.4.4 GTE's single point of contact will provide or will arrange to provide to AT&T any information known or available to GTE regarding environmental, health and safety matters for each GTE Structure in or on which AT&T seeks an Attachment no later than the time that GTE approves an AT&T Attachment Request. Information is considered available if it is in GTE's possession. GTE represents that the information provided by GTE will be the best information available to GTE at the time the information is provided. GTE does not represent that any information provided reflects the actual condition of the Structure at the time the information is provided, or at the time AT&T enters or seeks an Attachment at the Structure, nor that no change has occurred in such conditions between the time such information is provided and the time AT&T enters or seeks an Attachment at the Structure, and AT&T acknowledges that no such representations are made, however, GTE shall inform AT&T of any changes in the information provided to AT&T as soon as practicable after the change is known or available to GTE.

3.5 **Authority to Place Attachments**

- 3.5.1 Before AT&T places any Attachment pursuant to an approved Attachment Request, AT&T shall submit evidence of its authority to erect and maintain the Facilities to be placed on GTE's Structures within the public streets, highways and other thoroughfares or on private property, where such authority is required by law. AT&T shall

be solely responsible for obtaining all licenses, authorizations, permits, and consent from federal, state and municipal authorities or private property owners that may be required to place Attachments on GTE's Structures.

- 3.5.2 GTE shall not unreasonably intervene against or attempt to delay the granting of any licenses, authorizations, permits or consents from federal, state and municipal authorities or private property owners that may be required for AT&T to place its Attachments on or in any poles, ducts, conduits, or rights of way, including those that GTE owns or controls.
- 3.5.3 If any license, authorization, permit or consent obtained by AT&T from an authority, which for the purposes of this Section 3.5.3 does not include GTE, is subsequently revoked or denied for any reason, permission to attach to GTE's Structures shall terminate immediately and AT&T shall remove its Attachments within the time required by such authorities, or absent such time, within ninety (90) days after AT&T receives notification of revocation or denial. AT&T may, at its option, litigate or appeal any such revocation or denial and if AT&T is diligently pursuing such litigation or appeal, AT&T may continue to maintain its Attachment. In doing so, AT&T agrees to indemnify GTE from and against any and all costs resulting from GTE's continuation of the Attachment which is the subject of such litigation or appeal. If AT&T does not appeal and AT&T fails to remove AT&T's Attachments within the above specified time period, GTE shall have the option to remove AT&T's Attachments and store them in a public warehouse at the expense of and for the account of AT&T without GTE being deemed guilty of trespass or conversion, and without GTE becoming liable for any loss or damage to AT&T's Attachments occasioned thereby. Alternatively, GTE may remove AT&T's Attachments and store them upon GTE's premises, in which event, GTE shall use the same standard of care to protect AT&T's Attachments that GTE uses for protecting GTE's own facilities and equipment. All reasonable costs incurred by GTE to remove AT&T's Attachments shall be reimbursed to GTE by AT&T upon demand.

3.6 **Capacity**

- 3.6.1 When there is insufficient space on a GTE pole or in a GTE conduit to accommodate an AT&T requested Attachment or occupancy, GTE shall take all reasonable steps to accommodate AT&T's requests for Attachments or occupancy where such access would require expansion of capacity. The costs of modifications required for expansion will be paid as provided in the FCC First Report and Order Paras. 1211-1216.

- 3.6.2 With GTE's consent, which consent shall not be unreasonably withheld, AT&T may break out of GTE conduit where there is no reasonable engineering alternative. Where required by GTE and upon forty-eight (48) hours prior notice from AT&T unless emergency circumstances dictate otherwise, GTE shall provide AT&T designated personnel with an escort service. Such escort service shall be available during normal business hours for such assignments. Prior to the start of work, AT&T and the GTE escort will discuss the manner in which the work will be performed and GTE's reasonable requirements for ensuring the integrity of the conduit, protecting the Facilities contained in the conduit, protecting personnel and public safety and for preventing service interruptions. GTE Outside Plant Personnel will determine whether escort services are required on a case by case basis. This determination will be based on AT&T's adherence to GTE's requirements for plant protection procedures and the industry-standard construction and access procedures used by AT&T. Nonetheless, GTE may require escort service in its sound discretion, provided, however, that AT&T shall not be required to reimburse GTE for more than the number of persons as are necessary and prudent for providing the appropriate escort service.
- 3.6.3 GTE shall permit manhole interconnections and breaking out of GTE manholes. Where required by GTE and upon forty-eight (48) hours prior notice from AT&T unless emergency circumstances dictate otherwise, GTE shall provide AT&T designated personnel with an escort service. Such escort service shall be available during normal business hours for such assignments. Prior to the start of work, AT&T and the GTE escort will discuss the manner in which the work will be performed and GTE's reasonable requirements for ensuring the integrity of the manhole structure, protecting the Facilities contained in the manhole structure, protecting personnel and public safety and for preventing service interruptions. GTE Outside Plant Personnel will determine whether escort services are required on a case by case basis. This determination will be based on AT&T's adherence to GTE's requirements for plant protection procedures and the industry-standard construction and access procedures used by AT&T. Nonetheless, GTE may require escort service in its sound discretion, provided, however, that AT&T shall not be required to reimburse GTE for more than the number of persons as are necessary and prudent for providing the appropriate escort service. GTE reserves the right to deny AT&T requests to break out of manholes where the break out does not occur at precast knockout locations or where the location in which AT&T wants to break out is blocked by cable rack.

3.6.4 GTE shall take all reasonable measures to allow access and/or egress to all conduit systems. This shall include but not be limited to GTE's removal, upon AT&T's request and at AT&T's expense by paying GTE the actual costs incurred, of any retired cable from conduit systems to allow for the efficient use of conduit space within a reasonable period of time. If the Parties are unable to agree on what is reasonable (in terms of measures or time intervals), the matter may be submitted according to the Alternate Dispute Resolution Process, described in Attachment 1, by either Party. The costs of removal will be paid as provided in the FCC First Report and Order Paras. 1211-1216.

3.6.5 [Intentionally deleted.]

3.6.6 Where a spare inner duct does not exist, GTE shall allow and AT&T shall be required to install all inner duct in a spare GTE conduit. If another attaching entity, including GTE, uses the inner duct installed by AT&T, GTE shall inform AT&T and such entity shall share in the depreciated cost of the installation of the inner duct in proportion to the amount of the inner duct being used by that entity.

3.6.7 GTE shall not attach, or permit other entities to attach Facilities on existing AT&T Facilities without AT&T's prior written consent.

3.7 **Sharing of Rights of Way**

3.7.1 GTE shall offer the use of such ROW it has obtained from a third party to AT&T, to the extent that GTE's agreement or easement with the third party does not prohibit GTE from granting such rights to AT&T. AT&T shall have the right to review the pertinent parts of the agreement or easement between GTE and the third party when GTE asserts that the agreement or easement prohibits the granting of such rights or if, having agreed to grant such rights, GTE refuses to warrant that it has the authority to grant such rights. In cases where GTE does not have the authority to grant access, GTE shall provide the owner contact information if known to GTE and will not interfere in AT&T's obtaining such access and shall not prevent or delay any third party assignment of rights-of-way to AT&T.

3.7.2 [Intentionally deleted.]

3.8 **Emergency Situations**

3.8.1 Within fifteen (15) business days after the Effective Date, GTE shall establish a non-discriminatory priority method to access GTE manholes and conduits in emergency situations.

3.9 **Attachment Fees**

3.9.1 AT&T shall pay to GTE an Attachment Fee, consistent with Applicable Law for each GTE Structure upon which AT&T obtains authorization to place an Attachment.

3.9.2 GTE shall maintain an inventory of the GTE Structures occupied by AT&T based upon the cumulative Facilities specified in all Requests for Attachment approved in accordance with Section 3.4 of this Attachment 3. AT&T shall have the right to remove any Attachment at any time, and it shall be AT&T's sole responsibility to notify GTE of any and all removals by AT&T of its Attachments from GTE's Structures. Such notice shall be provided to GTE at least thirty (30) days prior to the removal of the Attachments and shall take the form of a Notice of Removal. AT&T shall remain liable for an Attachment Fee for each GTE facility included in all approved Attachment Requests until the Attachment is removed by AT&T. GTE may, at its option, conduct a physical inventory of AT&T's Attachments for purposes of determining the Attachment Fees to be paid by AT&T under this section.

3.10 **Additions and Modifications to Existing Attachments**

3.10.1 AT&T shall not modify, add to or replace Facilities on any pre-existing Attachment without first notifying GTE in writing of the intended modification, addition or replacement at least thirty (30) days prior to the date the activity is scheduled to begin. The required notification shall include: (1) the date the activity is scheduled to begin, (2) a description of the planned modification, addition or replacement, (3) a representation that the modification, addition or replacement will not require any space other than the space previously designated for AT&T's Attachments, and (4) a representation that the modification, addition or replacement will not impair the structural integrity of the Structures and Facilities involved.

3.10.2 If the modification, addition or replacement specified by AT&T in its notice will require more space than that allocated to AT&T or will require the reinforcement of replacement of or an addition of support equipment to the Structures or Facilities involved in order to accommodate AT&T's modification, addition or replacement, AT&T will submit a Attachment Request in compliance with this Section in order to obtain authorization for the modification, addition or replacement of its Facilities.

3.11 **Charges for Unauthorized Attachments**

3.11.1 It is agreed that a charge equal to two (2) times the amount of the then current Attachment Fee shall be paid by AT&T to GTE for each Unauthorized Attachment to a GTE Structure for the period of time for which the Attachment is unauthorized provided that the lack of authorization as due to the act, or failure to act, of AT&T. Such payment shall be deemed liquidated damages and not a penalty. AT&T also shall pay GTE an Attachment Fee for each Unauthorized Attachment accruing from the date the Unauthorized Attachment was first placed on the GTE Structure. In the event that the date the Unauthorized Attachment was first placed on a GTE Structure cannot be determined, such date shall be deemed the date of the last physical inventory made in accordance with this Agreement or, if no physical inventory has been conducted, the date the first Attachment Request from AT&T was approved in accordance with this Agreement. If AT&T elects to leave the Attachment in place, AT&T also shall pay to GTE all costs incurred by GTE to rearrange any Unauthorized Attachment(s) of AT&T in order to accommodate the Attachment(s) of another party whose Attachment(s) would not have required a rearrangement but for the presence of AT&T's Unauthorized Attachment(s). If AT&T elects to leave the Attachment in place, AT&T shall also pay to GTE all costs incurred by GTE to reinforce, replace or modify a GTE Structure, which reinforcement, replacement or modification was required as a result of the Unauthorized Attachment of AT&T. The Attachment Fee referenced in this subsection shall be determined in the same manner as such fee would have been determined if the Attachment had been authorized by GTE.

3.11.2 For purposes of this section, an Unauthorized Attachment shall include, but not be limited to: (a) an Attachment on or in any GTE Structure, which Structure is not identified in any Attachment Request approved in accordance with this Attachment 3; (b) an Attachment that occupies more space than that allocated to AT&T by GTE; (c) an addition or modification to a pre-existing Attachment that impairs the structural integrity of the involved GTE Structure or Facilities; (d) an Attachment installed by AT&T for the use of a party other than AT&T. An Unauthorized Attachment does not include an Attachment which AT&T demonstrates was made mistakenly, but in good faith pursuant to an approved Attachment Request for another location(s).

3.12 **Surveys and Inspections of Attachments**

3.12.1 The exact location of AT&T's Attachments on or in GTE's Structures may be determined, at GTE's discretion, through a survey to be made by GTE. If so requested, AT&T and/or any other entity owning or jointly owning the Structures with GTE may participate in the survey. If

the survey reveals one or more unauthorized Attachments by AT&T, AT&T shall reimburse GTE all expenses incurred in conducting the survey.

- 3.12.2 Apart from surveys conducted in accordance with Section 3.12.1 above, GTE shall have the right to inspect any Attachment of AT&T on or in GTE's Structures as conditions may warrant. No joint survey or inspection by GTE shall operate to relieve AT&T of any responsibility, obligation or liability assumed under this Agreement.

3.13 **Notice of Modification or Alteration of Structures by GTE**

If GTE plans to modify or alter any GTE Structures upon which AT&T has Attachments, GTE shall provide AT&T notice of the proposed modification or rearrangement at least sixty (60) days prior to the time the proposed modification or alteration is scheduled to take place. AT&T shall be allowed to participate with GTE in such modification or rearrangement. AT&T shall make all rearrangements of its Facilities within such period of time as is jointly determined to be reasonable by the Parties based on the amount of rearrangements necessary and a desire to minimize chances for service interruption or facility-based service denial to an AT&T customer.

To the extent AT&T benefits from such modification or rearrangement or obtains access to such Structure as a result of the modification, AT&T shall pay GTE AT&T's proportionate share of the costs incurred. If AT&T has a preexisting Attachment to the modified Structure it shall be deemed to directly benefit from a modification if, after receiving notification of such modification, it adds to or modifies its Attachment. Notwithstanding the foregoing, if AT&T has a preexisting attachment to a Structure it shall not be required to bear any of the costs of rearranging or replacing its Attachment if such rearrangement or replacement is necessitated solely as a result of an additional Attachment or the modification of an existing Attachment sought by a third party or GTE. If AT&T makes an Attachment to the Structure after the completion of the modification, it shall share proportionately in the cost of the modification with GTE and any contributing third parties, if such modification rendered possible the added Attachment.

3.14 **Default and Remedies**

- 3.14.1 The occurrence of any one of the following shall be deemed a Material Default by AT&T: (a) Failure by Licensee to perform or observe any term, condition, covenant, obligation or provision of this Attachment 3 and such default continues for a period of thirty (30) days after written

notice thereof from GTE (provided that if such default is not curable within such thirty (30) day period, the period will be extended if Licensee commences to cure such default within such thirty (30) day period and proceeds diligently thereafter to effect such cure);
(b) AT&T's knowing use or maintenance of its Attachments in violation of any law or regulation, or in aid of any unlawful act or undertaking;
(c) If any authorization which may be required of AT&T by any governmental or private authority for the placement, operation or maintenance of AT&T's Attachments is denied or revoked, and any appeals or other actions for review of such denial or revocation have been completed.

3.14.2 In the event of a Material Default, the provisions of Section 3.18.1 shall apply.

3.14.3 All rights and remedies of GTE set forth in this Agreement shall be cumulative and none shall exclude any other right or remedy, now or hereafter allowed by or available under any statute, ordinance, rule of court, or the common law, either at law or in equity, or both, except that GTE may not exercise any of the remedies set forth in Section 3.14.2 if such Material Default is the subject of Alternate Dispute Resolution procedures as set forth in Attachment 1 to the Agreement.

3.15 **Termination of Section 3 by AT&T**

3.15.1 Section 3 of Attachment 3 of this Agreement may be terminated by AT&T any time prior to the expiration of its term by providing written notice to GTE of its intent to terminate not less than ninety (90) days prior to the date such termination is to become effective. Within ninety (90) days after the date this Section 3 is terminated, AT&T shall cause all of its Attachments to be removed from all of GTE's poles. In the event AT&T fails to remove its Attachments as required by this section, GTE shall have the option to remove all such Attachments and store them in a public warehouse or elsewhere at the expense of and for the account of AT&T without GTE being deemed guilty of trespass or conversion, and without GTE becoming liable for any loss or damages to AT&T occasioned thereby.

3.16 **Indemnification**

AT&T shall indemnify GTE as set forth in Section 10 of the General Terms and Conditions of this Agreement.

3.17 **Abandonment**

3.17.1 Nothing in this Agreement shall prevent or be construed to prevent GTE from abandoning, selling, assigning or otherwise disposing of any poles, conduit systems, or other GTE property used for AT&T's Attachments, provided, however, that GTE shall condition any such sale, assignment or other disposition subject to the rights granted to AT&T pursuant to this Agreement. GTE shall promptly notify AT&T of any proposed sale, assignment or other disposition of any Structures or other GTE property used for AT&T's Attachments.

3.18 **Alternate Dispute Resolution**

3.18.1 If GTE has declared AT&T in default of any provisions of this Section 3, or has otherwise notified AT&T that AT&T is not in compliance with the terms of this Section 3, either party may invoke the Alternate Dispute Resolution Process, described in Attachment 1, or the procedures described in the Act, the *FCC's First Interconnection Order*, § 1217-1231 and the FCC's Rules at 47 CFR §1.1401-1.1416. GTE will continue to process Attachment Requests pursuant to this Section 3.18.1 so long as ADR or one of the other procedures described in this section has been initiated and is still pending.

3.18.2 GTE will not be relieved of its obligations to process Attachment Requests by AT&T if AT&T is alleged to be in default of this Section 3 for nonpayment of fees and charges due GTE under this Section 3, so long as such default is (1) the subject of good faith negotiations; (2) the subject of Alternate Dispute Resolution procedures as set forth in Attachment 1 to the Agreement; or (3) being adjudicated before the FCC or any other court, regulatory body, agency, or tribunal having jurisdiction over such dispute.

ATTACHMENT 4

**PROVISIONING AND ORDERING
FOR UNBUNDLED ELEMENTS**

TABLE OF CONTENTS

Section.....	Page
1. NETWORK DEPLOYMENT.....	1
2. GENERAL PROVISIONING REQUIREMENTS.....	1
3. SPECIFIC PROVISIONING PROCESS REQUIREMENTS.....	2
4. GENERAL ORDERING REQUIREMENTS.....	3
5. ORDERING INTERFACES.....	4
6. GTE PROVISION OF INFORMATION.....	5
7. ORDER FORMAT AND DATA ELEMENTS FOR INDIVIDUAL NETWORK ELEMENTS.....	6
8. ORDER FORMAT AND DATA NETWORK ELEMENTS FOR COMBINATIONS	7
[Combinations]	
9. PERFORMANCE REQUIREMENTS.....	7

Provisioning and Ordering

1. Network Deployment

1.1 GTE shall complete on a timely basis AT&T's orders for Network Elements **and Combinations** and for services that GTE is required to offer to AT&T pursuant to this Agreement in all its serving areas from and after the Effective Date of this Agreement. To the extent sections contained in this Attachment set forth technical references, technical standards, technical requirements, and/or performance standards, GTE's obligation to comply with such references, requirements, and/or standards shall be subject to Section 23.19 of the General Terms and Conditions of this Agreement.

[Combinations]

1.2 Throughout the term of this Agreement, the quality of the technology, equipment, facilities, processes, and techniques (including, without limitation, such new architecture, equipment, facilities, and interfaces as GTE may deploy) that GTE provides to AT&T under this Agreement must be at least equal in quality to that provided by GTE to itself.

2. General Provisioning Requirements

2.1 AT&T may order Network Elements, in accordance with this Agreement, individually **and in any combination so long as the combination is technically feasible. Combinations are Network Elements that are specified by AT&T for a geographic area or for a specific customer.**

[Combinations]

2.2 **Combinations shall be identified and described by AT&T so that they can be ordered and provisioned together.**

[Combinations]

2.3 **Combinations may be ordered by AT&T from GTE on a single order without the need to have AT&T send an order for each Network Element. The Parties agree to negotiate in good faith on the adoption of any subsequent forms or formats approved by the OBF.**

[Combinations]

2.4 GTE shall provide provisioning services to AT&T on the same days/hours that it provides such services to itself. These days currently are Monday through Friday from 8:00 a.m. to 5:00 p.m., within each respective time zone. AT&T may

request GTE to provide Saturday, Sunday, holiday, and off-hour provisioning services. If AT&T requests that GTE perform provisioning services at times or on days as stated in the preceding sentence, GTE shall quote, within one (1) day of the request, a cost-based rate for such services. If AT&T accepts GTE's quote, GTE shall perform such provisioning services and AT&T will pay the agreed-upon rates.

2.5 GTE shall provide a Single Point of Contact (SPOC) for all ordering and provisioning activities involved in the purchase and provisioning of GTE's Network Elements **or Combinations**. GTE shall also provide to AT&T a toll-free nationwide telephone number (operational from 8:00 a.m. to 5:00 p.m., Monday through Friday, within each respective time zone) which will be answered by capable staff trained to answer questions and resolve problems in connection with the provisioning of Network Elements **or Combinations**, and other orders made under this Agreement.

[Combinations]

2.6 GTE will recognize AT&T as the customer of record of all Network Elements **and Combinations** ordered by AT&T and will send all notices, invoices and pertinent information directly to AT&T.

[Combinations]

3. **Specific Provisioning Process Requirements**

3.1 When requested by AT&T, GTE will schedule installation appointments (GTE employee dispatch) with GTE's representative on the line with AT&T's representative or provide AT&T access to GTE's scheduling system. GTE will provide appropriate training for all its employees who may interface with AT&T's customers.

3.2 GTE shall provide intercept and transfer services to AT&T for AT&T Customers on the same basis as such service is available to similarly-situated GTE customers. GTE shall provide a recorded announcement to (i) notify a calling party that the end user customer has transferred to a new telephone number of AT&T and (ii) provide such calling party with details concerning the new telephone number to be dialed to reach the customer. GTE shall provide such announcement for the same length of time that GTE provides intercept or referral information for its customers that have changed telephone numbers.

3.3 GTE will provide AT&T with a Firm Order Confirmation (FOC) for each order, as specified in Attachment 12. The FOC will contain an enumeration of AT&T's ordered Network Elements **or Combinations** (consisting of circuit number, telephone number and/or component ID), PON, version, and GTE's commitment date for order completion (Committed Due Date).

[Combinations]

- 3.4 Upon work completion, GTE will provide AT&T electronically (unless otherwise requested by AT&T) with an Order Completion for each order that states when that order was completed. GTE shall respond with specific order detail as enumerated on the FOC and shall state any additional charges (e.g., time and cost charges) up to a previously agreed-upon limit associated with that order that may be applicable.
- 3.5 GTE will perform pre-testing in accordance with industry standards. Where such test results are recorded, they will be provided to AT&T electronically or in writing (as directed by AT&T) at installation/turn-up. Where provision of such test results is not included in the underlying network element charge, AT&T will pay for such test results at GTE's cost.
- 3.6 As soon as identified and unless otherwise agreed, GTE shall provide notification electronically of any rejections or errors contained in any of the Data Element fields contained on any AT&T order.
- 3.7 As soon as identified and unless otherwise agreed, GTE shall provide notification electronically of any instances when GTE's committed due dates are in jeopardy of not being met by GTE on any aspect or feature contained in any AT&T order. GTE shall concurrently indicate its new Committed Due Date.

- 3.8 At AT&T's request, GTE will cooperate with AT&T to test Network Elements **or Combinations** purchased by AT&T in order to identify any performance problems identified at turn-up, including trouble shooting to isolate any problems.

[Combinations]

- 3.9 AT&T will designate the AIN features which GTE is to provide for the AT&T customer on AT&T's provisioning order.
- 3.10 GTE shall not reassign an AT&T Customer's AIN Trigger from an AT&T AIN application to some other service provider's application.

4. General Ordering Requirements

- 4.1 Upon AT&T's request through a Suspend/Restore Order, GTE shall suspend or restore the functionality of any Network Element **or Combination**. GTE shall suspend or restore each Network Element **or Combination** in a manner that conforms with AT&T's requested priorities and any applicable regulatory policy or procedures at appropriate service order charges to the extent not otherwise included in the underlying element cost.

[Combinations]

- 4.2 GTE shall offer to AT&T the functionality of blocking calls (e.g., 800, 900, 976 international calls) by line or trunk.
- 4.3 GTE shall offer separate interLATA and intraLATA capabilities (i.e., 2 PICs where available) on a line or trunk basis.

- 4.4 Unless otherwise directed by AT&T, when AT&T orders a Network Element **or technically feasible Combination**, all pre-assigned trunk or telephone numbers currently associated with that Network Element **or technically feasible Combination** shall be retained without loss of feature capability and without loss of the associated Ancillary Functions including, but not limited to, Directory Assistance and 911/E911 capability.

[Combinations]

- 4.5 When AT&T orders Network Elements **or technically feasible Combinations** that are currently interconnected and functional, such Network Elements **and technically feasible Combinations** will remain interconnected and functional without any disconnection or disruption of functionality.

[Combinations]

5. **Ordering Interfaces**

- 5.1 GTE shall provide to AT&T a Real Time Electronic Interface (EI) for transferring and receiving orders, FOCs, Order Completions, and other provisioning data and materials (e.g., access to Street Address Guide (SAG) and Telephone Number Assignment Data Base) as provided in Section 29.1 of this Agreement.
- 5.2 With the customer authorization required by law, the permanent gateway shall provide AT&T's representatives with Real Time access to GTE customer information systems which will allow the AT&T representatives to perform the following tasks, if such information systems support GTE's retail business:
 - 5.2.1 Obtain AT&T customer profile, including AT&T customer name, billing and residence address, billed telephone numbers, and identification of features and services subscribed to by AT&T's customer;
 - 5.2.2 Obtain information on all features and services available, in the end-office where the AT&T customer is provisioned;
 - 5.2.3 Enter the order for the desired features and services;

- 5.2.4 Provide an assigned telephone number (if the AT&T customer does not have one assigned). Reservation and aging of these numbers shall remain GTE's responsibility;
- 5.2.5 Establish the appropriate directory listing;
- 5.2.6 Determine if a service call is needed to install a line or service;
- 5.2.7 Provide service availability dates to the AT&T customer;
- 5.2.8 Provide information regarding dispatch and installation schedules, if applicable;
- 5.2.9 Suspend, terminate, or restore service to an AT&T customer.

6. **GTE Provision of Information**

- 6.1 GTE shall provide to AT&T upon request and AT&T shall pay the required charge as part of the underlying element:
 - 6.1.1 A list of all services and features Currently Available from each switch that GTE may provide Local Switching, by switch CLLI;
 - 6.1.2 A listing by street address detail of the service coverage area of each switch CLLI;

6.1.3 All engineering design and layout information for each Network Element **and Combination**;

[Combinations]

6.1.4 A listing of all Currently Available functionalities for each Network Element **or Combination**; and

[Combinations]

6.1.5 Advanced information on the details and requirements for planning and implementation of NPA splits. GTE shall provide such information to AT&T within thirty (30) days from the time the GTE becomes aware of such information.

6.2 Within thirty (30) days after the Effective Date of this Agreement, GTE shall provide AT&T with an initial electronic copy and a paper copy of the SAG or its equivalent. Prior to the time that updates are available electronically, updates will be provided to AT&T on a monthly basis. Thereafter, updates shall be provided to AT&T as changes are made to the SAG.

7. **Order Format and Data Elements for Individual Network Elements**

7.1 AT&T and GTE shall each use the appropriate Data Elements for the ordering and provisioning of Network Elements **and Combinations**.

[Combinations]

7.2 Each order for a Network Element **or a Combination** will contain the following order-level sections, as then currently defined by the Ordering and Billing Forum (OBF), including, as appropriate, Administration, Bill, and Contact Information. This information is contained on both the ASR and LSR forms. In addition, each Network Element **or Combination** to be used for a specific AT&T End User customer shall contain the End User Information section.

[Combinations]

7.3 AT&T and GTE will use the OBF formats defined below for the exchange of ordering and provisioning data for Network Elements **or Combinations**. AT&T shall use the ASR forms and processes for ordering Network Elements that AT&T will use to serve more than one End User customer and the LSR form and processes for ordering Network Elements that AT&T will use to serve a single End User customer. AT&T and GTE shall use the forms and formats that have been approved by the OBF and, if mutually agreed, those that have reached the "initial closure" status at the OBF. If AT&T needs to order or have provisioned Network Elements **or Combinations** for which OBF approved or "initial closure" forms and formats do not yet exist, AT&T and GTE shall, within 30 days of a request by either party to do so, jointly develop a proposal for such forms and formats. AT&T and GTE shall use the jointly proposed forms and formats for the exchange of ordering and provisioning data unless the OBF modifies such forms and formats upon "initial closure" or final approval. If the OBF modifies such forms and formats upon "initial closure" or final approval, AT&T and GTE shall, upon mutual agreement, use the forms and formats as modified by the OBF. If AT&T and GTE do not agree on the interim forms and formats described in this Section, either Party may submit any disputed issues to the Alternative Dispute Resolution process in accordance with this Agreement.

[Combinations]

7.4 When ordering a Network Element (**individually or as part of a technically feasible Combination**), the interconnection characteristics and functionality of that Network Element will not be specifically ordered by AT&T and will automatically be provided by GTE.

[Combinations]

8. **Order Format and Data Network Elements for Combinations**

8.1 **AT&T may purchase Combinations (i) on a case-by-case basis for those Network Elements that are AT&T customer-specific (hereinafter referred to as Customer-Specific Network Elements or Combinations); or (ii) on a common-use basis for those Network Elements that are shared by multiple AT&T customers (hereinafter referred to as Common-Usage Network Elements or Combinations).**

8.2 **When ordering a Combination, AT&T will have the option of ordering all capabilities and functionalities of each of the individual Network Elements that comprise the Combination.**

8.3 **When ordering either Customer-Specific Combinations or Common-Usage Combinations, AT&T may specify the functionality of that Combination without the need to specify the configuration of the individual Network Elements needed to perform that functionality. AT&T will specify the Elements that make up each of the Combinations necessary to satisfy the request.**

8.4 **Prior to providing Local Service in a specific geographic area or when AT&T requires a change of network configuration, AT&T may place an order with GTE requiring GTE to implement the capability. AT&T may request the establishment of Common Usage Network Elements or Combinations by use of the negotiated ordering methods and forms. The initial order requesting Unbundled Switching, recording and associated trunking, which shall be in a mutually agreed format, will be known as a "Footprint Order".**

[Combinations]

9. **Performance Requirements**

9.1 **AT&T will specify on each order its Desired Due Date (DDD) for completion of that particular order. GTE will not complete the order prior to the DDD or later than the DDD unless authorized by AT&T. If the time period from the date of the order to the DDD is less than the intervals for provisioning Network Elements, **Combinations** and the Footprint Order as set forth in the following table, and is also less than the intervals for provisioning the same or like Network Elements, **Combinations** and Footprint Orders that GTE provides to itself or to any third party, the order will be considered an expedited order.**

[Combinations]

INTERVALS FOR ORDER COMPLETION	
<u>Network Element, Combination or Footprint Order</u>	<u>Number of Days¹</u>
Loop Distribution	
Loop Concentrator/Multiplexer	
Loop Feeder	
Local Switching and Tandem Switching	
Operator System	
Dedicated Transport and Common Transport DS0, DS-1, T 1.5 STS-1, DS3/T3 OC-3, +	
Signaling Transfer Points	
Signaling Link Transport	
SCPs/Databases	
Loop Combination	
Footprint Order	

[Combinations]

- 9.2 Within two (2) Business Hours after a request from AT&T for an expedited order, GTE shall notify AT&T if GTE will complete, or not complete, the order within the expedited interval. A Business Hour is any hour occurring on Monday through Friday, exclusive of national holidays, between 8 a.m. and 8 p.m. within each respective time zone.
- 9.3 Once an order has been issued by AT&T and if AT&T subsequently requires a new DDD that is earlier than the original DDD, AT&T will issue an expedited modify order. GTE will notify AT&T within two (2) Business Hours if it will complete, or not complete, the order on the new DDD.

¹ For each of the indicated Network Elements, Combinations and Footprint Orders listed in the Table, the intervals (i.e., number of days) will be established by the Implementation Team within 90 days of the Effective Date of this Agreement.

- 9.4 AT&T and GTE will agree to escalation procedures and contacts. GTE shall notify AT&T of any modifications to these contacts within one (1) week of such modifications.

ATTACHMENT 5

MAINTENANCE FOR LOCAL SERVICES RESALE

AND UNBUNDLED ELEMENTS

1. GTE shall provide repair, maintenance, and testing for all Local Services and Unbundled Network Elements **and Combinations** on an individual basis in accordance with the terms and conditions of this Attachment. In addition, GTE shall provide surveillance for all Local Services and Unbundled Network Elements **and Combinations** to the same extent that GTE provides such surveillance for itself. To the extent sections contained in this Appendix set forth technical references, technical standards, technical requirements, and/or performance standards, GTE's obligation to comply with such references, requirements, and/or standards shall be subject to Section 23.19 of the General Terms and Conditions of this Agreement.

[Combinations]

2. GTE shall cooperate with AT&T to meet maintenance standards for all Local Services and Unbundled Network Elements **and Combinations** ordered under this Agreement, as specified in Section 9 of this Attachment. GTE shall otherwise meet Commission maintenance and repair standards, if any, with respect to Local Services, and Unbundled Network Elements **and Combinations**.

[Combinations]

3. GTE shall cooperate with AT&T to establish a Real Time Electronic Interface for gateway or automated access by AT&T to GTE's maintenance systems and databases as provided in Section 29.1 of this Agreement.
4. GTE service technicians and other repair personnel shall provide repair service to AT&T customers that is at least equal in quality to that provided to GTE customers. GTE's operating policies, procedures and practices shall apply in all such repair service situations without regard to whether the customer is a GTE customer or an AT&T customer.

5. For all Local Services and, Network Elements **and Combinations** provided to AT&T under this Agreement, GTE shall provide the same maintenance, including, without limitation, maintenance intervals and procedures, that GTE provides for its own network, provided however, that with respect to any Network Element(s) AT&T combines, GTE shall be responsible only for

maintenance of the individual Network Element(s) provided pursuant to this Agreement, and under no event or circumstance shall GTE be responsible for the end-to-end performance of any combination of Network Elements provided pursuant to this Agreement or otherwise. GTE shall provide AT&T notice within one business day of the scheduling of any maintenance activity which may impact AT&T's Customers. Scheduled maintenance shall include, without limitation, such activities as, switch software retrofits, power tests, major equipment replacements and cable rolls; provided, however, that such activity is not related to a network or technology change covered elsewhere in this Agreement. Plans for scheduled maintenance shall include, at a minimum, the following information: location and type of facilities, work to be performed, date and time work is scheduled to commence, and date and time work is scheduled to be completed.

[Combinations]

6. GTE shall advise AT&T of all non-scheduled maintenance and testing activity to be performed by GTE on any network element, including, without limitation, any hardware, equipment, software, or system, providing service functionality that may reasonably be expected to impact AT&T Customers. GTE shall provide the maximum amount of advance notice to AT&T of such non-scheduled maintenance and testing activity as is reasonably practical, under the circumstances; provided, GTE shall provide emergency maintenance as promptly as possible under the circumstances, to maintain or restore service and shall advise AT&T promptly of any such actions it takes.

7. Major network outages will be reported to AT&T via a telephone number designated by AT&T. GTE and AT&T shall work cooperatively on the establishment of emergency restoration procedures. GTE may invite other carriers to join in this effort. In establishing such procedures, consideration shall be given to: (i) provision for immediate notification to AT&T of the existence, location, and source of any emergency network outage potentially affecting customers; (ii) establishment of a single point of contact responsible for initiating and coordinating the restoration of all Local Services and Network Elements **or Combinations**; (iii) methods and procedures to provide access to information relating to the status of restoration efforts and problem resolution during the restoration process; (iv) an inventory and description of mobile restoration equipment, by location; (v) methods and procedures for the dispatch of mobile equipment to the restoration site; (vi) methods and procedures for reprovisioning of all Local Services and Network Elements **or Combinations** after initial restoration; (vii) priority, as between AT&T Customers and GTE Customers, with respect to restoration efforts, consistent with FCC Service Restoration guidelines, including, without limitation, deployment of repair personnel, and access to spare parts and components; and (viii) a mutually agreeable process for escalation of maintenance

problems, including a complete, up-to-date list of responsible contacts, each available twenty-four (24) hours per day, seven (7) days per week. Said plans shall be modified and up-dated as needed.

[Combinations]

For purposes of this subsection, a major network outage is defined as 5,000 or more blocked call attempts in a ten (10) minute period in a single exchange. GTE shall provide timely notification to AT&T of any outage.

8. With respect to misdirected calls from AT&T customers requesting repair, GTE shall refer such AT&T customers to the telephone number designated by AT&T. With respect to misdirected calls from GTE customers requesting repair, AT&T shall refer such GTE customers to the telephone number designated by GTE.
9. Repair and maintenance services provided by GTE to AT&T and AT&T Customers under this Agreement shall, in accordance with Section 11.2 of the General Terms and Conditions of this Agreement, be equal in quality to those GTE provides to itself.
 - 9.1 [Intentionally deleted.]
 - 9.2 AT&T and GTE will develop mutually agreed-upon manual processes for repair reporting in the event of unavailability or failure of the Electronic Interface.
 - 9.3 GTE's repair bureau shall provide to AT&T the "estimated time to restore" for all DS1 or higher capacity services at performance standard levels determined by the Implementation Team. GTE shall provide all other classes of service restoral commitment(s) as specified in Appendix 2 of Attachment 12 to this Agreement.
 - 9.4 [Intentionally deleted.]
 - 9.4.1 [Intentionally deleted.]
 - 9.4.2 [Intentionally deleted.]
 - 9.4.3 [Intentionally deleted.]
 - 9.5 GTE shall provide progress reports and status of repair efforts to AT&T upon request. GTE will notify AT&T of restoration of service prior to internally closing the trouble ticket. The objective for the time within which such notification is to occur shall be within one (1) hour of restoration of Local Service or Network Element **or Combination** after a network outage has occurred. The Parties shall work together to achieve such objective. GTE shall

clear all repair tickets in compliance with GTE policies and guidelines. GTE shall close all repair tickets, including "test OK" ("TOK") and "Came Clear" ("CC") repair tickets, with the AT&T work centers designated by AT&T on the repair ticket, unless a different notification procedure is mutually agreed to by the Parties. GTE shall make one attempt to notify AT&T of closed repair tickets using a mutually agreed to notification method. At AT&T's option, AT&T shall contact the Customer to verify that the repair has been effected. GTE shall provide AT&T with a list of any applicable charges, as specified in Attachment 14, at the time a repair ticket is closed.

[Combinations]

- 9.6 When, in AT&T's judgment, any repair ticket or tickets are not being handled or resolved by GTE personnel in a timely manner, AT&T may escalate the matter for review and resolution under such procedures as are now available or may be established between the Parties during the term of this Agreement.
- 9.7 Except with respect to charges for inside wire maintenance, maintenance charges for premises visits by GTE technicians shall be billed by AT&T to its Customer, and not by GTE. The GTE technician shall present the Customer with an AT&T-branded form. Additional authorization for time and material charges shall be provided by AT&T using the agreed-to notification process.
- 9.8 Dispatching of GTE technicians to AT&T Customer premises shall be accomplished by GTE pursuant to a repair request received from AT&T and non-recurring charges shall apply as provided in Attachment 14. Any additional trips required to an AT&T Customer's premise because the Customer was not ready/available will result in an additional non-recurring charge.
- 9.9 GTE shall furnish AT&T with a single point of contact ("SPOC") for all communications relating to trouble repair and maintenance for POTS services; for special services, GTE will provide AT&T with a single point of contact on a regional basis.

ATTACHMENT 6
LOCAL SERVICES RESALE, UNBUNDLED NETWORK ELEMENT AND
INTERCONNECTION BILLING AND RECORDING

1. **GENERAL**

This Attachment contains the provisions applicable to billing and payment of all charges AT&T incurs for purchasing wholesale Local Services for resale and Unbundled Network Elements **and Combinations**, and the billing and payment procedures to be followed when AT&T is interconnected to GTE Network Facilities. The specific provisions for Local Service Billing are set forth in Appendix A; the specific provisions for Unbundled Network Element billing are set forth in Appendix B; and the specific provisions for Interconnection Billing are set forth in Appendix C.

[Combinations]

2. **ADDITIONAL REQUIREMENTS**

The following provisions shall, when applicable, govern Local Service, Unbundled Network Element and Interconnection Bills.

2.1 **BILL ACCURACY CERTIFICATION AND VALIDATION**

2.1.1 The Parties agree that as further set forth in accordance with this Attachment 6 and in order to ensure the proper performance and integrity of the entire Billing process, GTE will be responsible and accountable for transmitting to AT&T accurate and current bills on a monthly basis. GTE agrees to implement control mechanisms and procedures to render a bill that accurately reflects the Elements, **Combinations** and Local Service ordered and used by AT&T. The Parties agree that under meet point billing both Parties are responsible and accountable for recording and transmitting to the other Party accurate and current billing data as specified in Attachment 6, Appendix C. In addition, the Parties agree to meet monthly or as deemed necessary by either Party to review and resolve potential billing discrepancies.

[Combinations]

- 2.1.2 AT&T and GTE shall use diligent and good faith effort to reach an agreement on the Bill Certification Methodology. The Access Billing Supplier Quality Certification Operating Agreement, dated December 7, 1992, as amended December 16, 1993, between GTE and AT&T shall be used as the model for a Local Service Resale and Unbundling Billing Certification Operating Agreement as appropriate. GTE and AT&T shall cooperate to develop mutually acceptable bill quality processes.
- 2.1.3 Until Bills and Data are certified pursuant to the Local Service Bill Certification Operating Agreement reached under Section 2.1.2 of this Attachment 6, Bill and Data accuracy will be validated through an interim process using mutually agreed procedures.
- 2.1.4 Subject to GTE's reasonable security requirements and except as may be otherwise specifically provided in this Agreement and in the Local Service Resale and Unbundling Billing Certification Operating Agreement contemplated by Section 2.1.2 of this Attachment 6, AT&T may audit GTE's books, records and other documents pertaining to the services provided to AT&T under this Agreement and billed in accordance with this Attachment 6 once in each Contract Year for the purpose of evaluating the accuracy of GTE's billing, data and invoicing. AT&T may employ other persons or firms for this purpose subject to the confidentiality provisions contained herein. Such audit shall take place at a time and place agreed on by the Parties no later than thirty (30) days after notice thereof to GTE. GTE shall have the right to review such audit and the findings.
- 2.1.5 Upon resolution of the audit, GTE shall promptly correct any error that is revealed in an audit, including making refund of any overpayment by AT&T or recording a charge for underpayment by AT&T, in each instance together with applicable interest, in the form of a credit or a debit on the invoice for the first full billing cycle after the Parties have agreed upon the accuracy of the audit results. Any Disputes concerning audit results shall be resolved pursuant to the Alternate Dispute Resolution procedures described in Attachment 1. Applicable Interest shall be as defined in Section 2.4.1.
- 2.1.6 Each Party shall cooperate fully in any such audit, providing reasonable access to any and all of its appropriate employees and relevant books, records and other documents of the party reasonably necessary to assess the accuracy of AT&T's orders and GTE's bills, data and invoices. Each Party shall bear its own costs and expenses of any audits.

2.2 PAYMENT OF CHARGES

2.2.1 GTE and AT&T will establish monthly billing dates ("Bill Date") for each Billing Account Number ("BAN"), and, when appropriate, as further defined in the applicable CABS document, which Bill Date shall be the same day month to month. Subject to the terms of this Agreement, AT&T and GTE will pay each other within the applicable periods set forth by Commission requirements, the last day of any such required period being the payment due date ("Payment Due Date"). If no such period(s) exist, the Payment Due Date shall be thirty (30) calendar days from the Bill Date. If the Payment Due Date is a Sunday or is a Monday that has been designated a bank holiday by the Chase Manhattan Bank of New York (or such other bank as the Parties specify), payment will be made the next business day. If the Payment Due Date is a Saturday or is on a Tuesday, Wednesday, Thursday or Friday that has been designated a bank holiday by the Chase Manhattan Bank of New York (or such other bank as the Parties specify), payment will be made on the preceding business day.

Each BAN shall remain constant from month to month, unless changed as agreed to by the Parties. Each Party shall provide the other Party at least thirty (30) calendar days written notice prior to changing, adding or deleting a BAN. The Parties will provide one Local Service Billing invoice, one Unbundled Network Element Billing invoice, or one Interconnection Billing invoice, as the case may be, associated with each BAN. Each invoice must contain an invoice number (which will vary from month to month). On each bill associated with a BAN, the appropriate invoice number and the charges contained on such invoice must be reflected. All Local Service Bills, Unbundled Network Element Bills, or Interconnection Bills, as the case may be, must be received by the other Party no later than ten (10) calendar days from the applicable Bill Date and at least twenty (20) calendar days prior to the applicable payment due date (as described in this Attachment), whichever is earlier. Any Local Service Bill, Unbundled Network Element Bill, or Interconnection Bill received on a Saturday, Sunday or a day designated as a holiday by the Chase Manhattan Bank of New York (or such other bank as AT&T shall specify) will be deemed received the next business day. If either Party fails to receive Local Service Billing data and information, Unbundled Network Element Billing data and information, or Interconnection Billing data and information, as the case may be, within the time period specified above, the Payment Due Date will be extended by the number of days the applicable Local Service Bill, Unbundled Network Element Bill, or Interconnection Bill is late.

2.2.2 Payments shall be made in U.S. Dollars via electronic funds transfer ("EFT") to the other Party's bank account. At least thirty (30) days prior to the first transmission of billing data and information for payment, GTE and AT&T shall provide each other the name and address of its bank, its account and routing number and to whom Billing payments should be made payable. If such banking information changes, each Party shall provide the other Party at least sixty (60) days written notice of the change and such notice shall include the new banking information. Notwithstanding any permitted assignment of this Agreement, AT&T will provide GTE with only one address to which such payments shall be rendered and GTE will provide to AT&T with only one address to which such payments shall be rendered. In the event AT&T receives multiple Bills from GTE which are payable on the same date, AT&T may remit one payment for the sum of all such Bills payable to GTE's bank account specified in this subsection. AT&T will provide specific account level detail for payment application. Each Party shall provide the other Party with a contact person or center for the handling of Billing payment questions or problems.

2.3 **BILLING DISPUTES**

2.3.1 Each Party agrees to notify the other Party in writing upon the discovery of a billing dispute. Such notification must occur within sixty (60) days of the Bill Date on which such disputed charges appear. In the event of a billing dispute, the Parties will endeavor to resolve the dispute within sixty (60) calendar days of the date on which the applicable Party receives written notification of such dispute. Resolution of the dispute will be attempted at all appropriate levels of management within the Parties respective billing organizations before use of the dispute resolution process in Attachment 1 resulting in a recommendation or settlement of the dispute and closure of a specific billing period.

2.3.2 If a Party disputes a Charge and does not pay such charge by the Payment Due Date, such charges shall be subject to late payment charges as set forth in the Late Payment Charges provision of this Attachment. If a Party disputes Charges and the dispute is resolved in favor of such Party, the other Party shall credit the bill of the disputing Party for the amount of the disputed charges along with any late payment charges applicable no later than the second bill Date after the resolution of the dispute. Accordingly, if a Party disputes Charges and the dispute is resolved in favor of the other Party, the disputing Party shall pay the other Party the amount of the disputed charges and any associated late payment charges applicable no later than the second bill Payment Due Date after the resolution of the dispute. In

no event, however, shall any late payment charges be assessed on any previously assessed late payment charges, unless Regulatory rules provide otherwise.

2.4 LATE PAYMENT CHARGES

2.4.1 If either Party fails to pay any Charges in this Attachment by the Payment Due Date, or if a payment or any portion of a payment is received by either Party after the Payment Due Date, or if a payment or any portion of a payment is received in funds which are not immediately available to the other Party, then interest shall be payable as a late payment penalty shall be assessed. The late payment interest rate shall be one and one-half (1 1/2) percent per month, or if lower the highest rate permitted by law, calculated based upon any portion of a payment not received by the Payment Due Date, compounded daily for the number of days from the payment date to and including the date that payment is actually made. In no event, however, shall interest be assessed on any previously assessed late payment charges, unless Regulatory rules provide otherwise. Notwithstanding any requirements set forth in this provision or any other provision contained within this Agreement, Late Payment Charges shall be calculated in accordance with applicable requirements, regulations, and allowances of the Commission.

2.5 RECORDING OF CALL INFORMATION

2.5.1 The Parties agree to record call information in accordance with this subsection. To the extent technical capability and capacity exists within a Party's existing systems, each Party will record agreed upon call detail information (i.e. the types and categories of call detail information each Party currently records for itself) associated with calls originated or terminated to the other Party's local exchange customer. These records shall be provided at a Party's request and shall, subject to Section 23.19 of the General Terms and Conditions of this Agreement, be formatted pursuant to applicable Bellcore standards and the terms and conditions of this Attachment. These records shall be transmitted as agreed upon to the other Party in EMR format via Connect:Direct capabilities. GTE and AT&T agree that they will retain, at each Party's sole expense, copies of all AMA records transmitted to the other Party for at least seven (7) calendar days after transmission to the other Party.

2.5.1.1 Until an industry standard solution for generating terminating AMA records is available, the Parties may elect an interim method such as

Terminating/Originating (T/O) factors for billing terminating rate elements. The Parties will mutually agree on the specific interim method, including establishing the criteria, application, and duration of such interim method.

- 2.5.2 Each Party will provide the other Party with a carrier identification code ("CIC") on each EMR record transmitted to the other Party. If GTE does not have a CIC for any local exchange carrier, ALEC or IXC for whom GTE must supply to AT&T Connectivity Billing records for information pursuant to this Attachment, GTE agrees that it will assist the local exchanger carrier, ALEC or IC in obtaining a CIC expeditiously. Until the local exchange carrier, ALEC or IXC has received a CIC, GTE agrees that it will submit its CIC to AT&T on those records for billing and payment. GTE further agrees that it will then be responsible for obtaining reimbursement for the respective charges from the appropriate carrier. Likewise, if AT&T does not have a CIC for any local exchange carrier, ALEC or IXC for whom AT&T must supply to GTE Billing records or information pursuant to this Attachment, AT&T agrees that it will assist the local exchange carrier, ALEC or IXC in obtaining a CIC expeditiously. Until the local exchange carrier, ALEC or IXC has received a CIC, AT&T agrees that it will submit its CIC to LEC on those records for billing and payment. AT&T further agrees that it will then be responsible for obtaining reimbursement for the respective charges from the appropriate carrier.
- 2.5.3 The Parties agree that they will meet the performance measurements for the provision of EMR records in Attachment 12.
- 2.5.4 The Parties agree that they will provide each other a single point of contact regarding any data exchange problems.

2.6 **EXAMINATION OF RECORDS**

- 2.6.1 Without waiver of and in addition to the Audit rights in the General part of this Agreement, upon reasonable notice and at reasonable times and in accordance with the bill quality processes currently in place, or as subsequently established pursuant to the Local Service Resale and Unbundling Billing Certification Operating Agreement contemplated by Section 2.1.2 of this Attachment, AT&T or its authorized representatives may examine GTE's documents, systems, records and procedures which relate to the billing and recording of the Charges to AT&T under this Attachment 6.

ATTACHMENT 6A

LOCAL SERVICES RESALE, BILLING AND RECORDING

TABLE OF CONTENTS

APPENDIX A 1

LOCAL SERVICE RESALE BILLING AND RECORDING 1

1. General..... 1

2. Billable Information And Charges..... 1

3. Issuance of Local Service Bills - General..... 2

4. Electronic Transmissions of Local Services Bills 3

5. Testing Requirements 4

APPENDIX A

LOCAL SERVICE RESALE BILLING AND RECORDING

1. General

This Section describes the specific requirements for GTE to bill and record all charges AT&T incurs for purchasing wholesale Local Services for resale.

2. Billable Information And Charges

2.1 GTE will bill and record in accordance with this Agreement those charges AT&T incurs as a result of AT&T purchasing from GTE wholesale Local Services, as set forth in this Agreement (hereinafter "Local Service Charges"). Each Local Service, purchased by AT&T shall be assigned a separate and unique billing code in the form agreed to by the Parties and such code shall be provided to AT&T on each Local Service Bill in which charges for such Elements, **Combinations**, or Local Services appear. Each such billing code shall enable AT&T to identify the Local Services ordered or utilized by AT&T in which Local Service Charges apply pursuant to this Agreement. Each Local Service Bill shall set forth the quantity and description of each such Local Service provided and billed to AT&T. All Local Service Charges billed to AT&T must indicate the state from which such charges were incurred.

[Combinations]

2.2 GTE shall provide AT&T a monthly Local Service Bill that includes all Local Service Charges incurred by and credits and/or adjustments due to AT&T for those Local Services ordered, established, utilized, discontinued or performed pursuant to this Agreement. Each Local Service Bill provided by GTE to AT&T shall include: (1) all non-usage sensitive charges incurred for the period beginning with the current bill date and extending to, but not including, the next bill date, (2) any known unbilled non-usage sensitive charges for prior periods, (3) unbilled usage sensitive charges for the period beginning with the day after the last bill date and extending up to, and including, the current bill date, (4) any known unbilled usage sensitive charges for prior periods, and (5) any known unbilled adjustments. The Local Service Bill shall also include all charges for Primary Interchange Carrier (PIC) changes and/or such other charges as are applicable as separate item(s) defined by billing telephone number and any associated working telephone number.

2.3 The Bill Date must be present on each bill transmitted by GTE to AT&T. Local Service Bills shall not be rendered for any Local Service Charges which

are incurred under this Agreement on or before one (1) year preceding the Bill Date except for charges resulting from resolution of an audit conducted pursuant to Section 2.1.4 of Attachment 6. In addition, on each bill where "Jurisdiction" is identified, Local Traffic charges shall be identified as "Local" and local toll charges identified as intrastate/intraLATA.

- 2.4 GTE shall bill AT&T for any wholesale Local Service, supplied by GTE to AT&T pursuant to this Agreement at the rates set forth in this Agreement. GTE will bill AT&T based on the actual Local Service Charges incurred, provided, however, for those usage based Local Service Charges where actual charge information is not determinable by GTE because the jurisdiction (i.e., interstate, interstate/interLATA, intrastate, intrastate/intraLATA, local) of the traffic is unidentifiable, the Parties will jointly develop a process to determine the appropriate charges. Measurement of usage-based Local Service Charges shall be actual conversation in tenths of seconds. The total conversation seconds per chargeable traffic types will be totalled for the entire monthly bill cycle and then rounded to the next whole minute.
- 2.5 Costs and expenses incurred in complying with this Attachment shall be calculated and allocated in accordance with Sections 42 and 43 of Part V of this Agreement.
- 2.6 Each Party shall provide the other Party at no additional charge a contact person or center for the handling of any Local Service Billing questions or problems that may arise during the implementation and performance of the terms and conditions of this Attachment.

3. **Issuance of Local Service Bills - General**

- 3.1 GTE and AT&T shall issue Local Service Bills as follows:
- 3.1.1 Until such time as the Parties agree otherwise, GTE and AT&T shall issue the information contained in official Local Service Bills via Electronic Data Exchange ("EDI").
- 3.1.2 GTE and AT&T will jointly work together such that on or as soon after July 1, 1998 as possible, GTE and AT&T shall issue the information contained in all official Local Service Bills in accordance with the format set forth in EDI 811, GTE Release #3.0, or such later EDI versions that are requested by AT&T and available from GTE at the time of such request and as mutually agreed by the Parties. If GTE changes internal releases, a differences list must be provided to AT&T 90 days prior to the release.
- 3.2 [Intentionally Deleted]

- 3.3 Each Party will provide the other Party written notice of which Local Service Bills are to be deemed the official bills. If either Party requests an additional copy(ies) of a bill, such Party shall pay the other Party a reasonable fee per additional bill copy or transmission as the case may be, unless such copy or transmission was requested due to errors, omissions, or corrections or the failure of the transmission to comply with the specifications set forth in this Agreement.
- 3.4 To avoid transmission failures or the receipt of Local Service Billing information that cannot be processed, the Parties shall provide each other with their respective process specifications and edit requirements. AT&T shall comply with GTE's processing specifications when AT&T transmits Local Service Billing data to GTE. GTE shall comply with AT&T's processing specifications when GTE transmits Local Service Billing data to AT&T. AT&T and GTE shall provide each other reasonable notice if a Local Service Billing transmission is received that does not meet such Party's specifications or that such Party cannot process. Such transmission shall be corrected and resubmitted to the other Party, at the resubmitting Party's sole expense, in a form that can be processed. The Payment Due Date for such resubmitted transmissions will be twenty (20) days from the date that the transmission is received in a form that can be processed and that meets the specifications set forth in this Attachment.

4. **Electronic Transmissions of Local Services Bills**

- 4.1 GTE and AT&T agree that on or as soon after July 1, 1998 as possible and following implementation of information delivery via EDI format pursuant to Section 3.1.2 of this Appendix A, each Party will transmit Billing information and data in the appropriate EDI format electronically via Connect: Direct (formerly known as Network Data Mover) to the other Party at the location specified by the Party. The Parties agree that a T1.5 or 56kb circuit to Gateway for Connect: Direct is required. AT&T data centers will be responsible for originating the calls for data transmission via switched 56kb or T1.5 lines. If GTE has an established Connect: Direct link with AT&T, that link can be used for data transmission if the location and applications are the same for the existing link. Otherwise, a new link for data transmission must be established. GTE must provide AT&T/Alpharetta its Connect: Direct Node ID and corresponding VTAM APPL ID before the first transmission of data via Connect:Direct. AT&T's Connect: Direct Node ID is "GTEDS.TTG" and VTAM APPL ID is "TSANDM" and must be included in LEC's Connect:Direct software. AT&T will supply to GTE its RACF ID and password before the first transmission of data via Connect:Direct. Any changes to either Party's Connect: Direct Node ID must be sent to the other Party no later than twenty-one (21) calendar days before the changes take effect.

4.2 The following dataset format shall be used as applicable for those Charges transmitted via Connect:Direct in EDI format:

Production Dataset

AF02.P.GTEXX.DATA.gdg	Production Dataset Name
AF02=	Job Naming Convention
P=	Production Node
GTEXX=	Company Name followed by XX
DATA=	Data received
gdg=	each transmission will be received as a generation (gdg) file

Test Dataset

AF02.P.GTEXX.TEST.DATA	Test Dataset Name
AF02 =	Job Naming Convention
P=	Production Node
GTEXX=	Company Name followed by XX
TEST =	Test Node
DATA =	Data Received

4.2.1 GTE agrees that if it transmits data to AT&T in a mechanized format utilizing EDI, GTE will also comply with the following specifications which are not contained in EDI guidelines but which are necessary for AT&T to process Billing information and data:

- The BAN shall not contain embedded spaces or low values.
- The Bill Date shall not contain spaces or non-numeric values.
- Each Bill must contain at least one detail record.
- Any "From" Date should be less than the associated "Thru" Date and neither date can contain spaces.
- The Invoice Number must not have embedded spaces or low values.
- State code representing the BAN location will be provided as a two byte character format.

5. **Testing Requirements**

5.1 The Parties will jointly develop a test procedure prior to sending mechanized bills or data to ensure to the satisfaction of each Party that bills may be processed as required in this Agreement.

5.2 GTE shall provide to AT&T's Company Manager, located at 500 North Point Parkway, FLOC B1104B, Alpharetta, Georgia 30302, GTE's originating or

state level company code so that it may be added to AT&T's internal tables at least thirty (30) calendar days prior to testing or prior to a change in GTE's originating or state level company code.

- 5.3 During the testing period, GTE shall transmit to AT&T any Billing data and information via electronic transmission as specified in Section 4. Test data shall be sent via tape, or other media mutually agreed to by both Parties, to AT&T at the following location:

Test Tapes:	AT&T 500 North Point Parkway FLOC B1104B Alpharetta, Georgia 30302 Attn: Access Bill Testing Coordinator
-------------	---

ATTACHMENT 6B

UNBUNDLED NETWORK ELEMENTS BILLING AND RECORDING

TABLE OF CONTENTS

APPENDIX B	1
UNBUNDLED NETWORK ELEMENT BILLING AND RECORDING	1
1. General.....	1
2. Billable Information And Charges	1
3. Collocation.....	2
4. Issuance of Unbundled Network Element Bills - General.....	3
5. Electronic Transmissions of Unbundled Network Element Bills	4
6. Testing Requirements	5
7. Local Number Portability	5

APPENDIX B
UNBUNDLED NETWORK ELEMENT BILLING AND RECORDING

1. **General**

This Section contains the provisions applicable to the billing and recording of all charges AT&T incurs for purchasing Unbundled Network Elements **and/or Combinations of Unbundled Network Elements**.

[Combinations]

2. **Billable Information And Charges**

2.1 GTE will bill and record in accordance with this Agreement those **Combinations** charges AT&T incurs as a result of AT&T purchasing from GTE Unbundled Network Elements **and/or Combinations of Unbundled Network Elements** as set forth in this Agreement (hereinafter "Unbundled Network Element Charges"). Each such Element, **or Combination thereof** purchased by AT&T shall be assigned a separate and unique billing code in the form agreed to by the Parties and such code shall be provided to AT&T on each Unbundled Network Element Bill in which charges for such Elements, **or Combinations** appear. Each such billing code shall enable AT&T to identify the Element(s), **or Combinations**, Objects and Options as described in Attachment 4 to this Agreement ordered or utilized by AT&T in which Unbundled Network Element Charges apply pursuant to this Agreement. Each Unbundled Network Element Bill shall set forth the quantity and description of each such Element, **or Combination** provided and billed to AT&T. All Unbundled Network Element Charges billed to AT&T must indicate the state from which such charges were incurred.

[Combinations]

2.2 GTE shall provide AT&T a monthly Unbundled Network Element Bill that includes all Unbundled Network Element Charges incurred by and credits and/or adjustments due to AT&T for those Elements, **or Combination thereof**, ordered, established, utilized, discontinued or performed pursuant to this Agreement. Each Unbundled Network Element Bill provided by GTE to AT&T shall include: (1) all non-usage sensitive charges incurred for the period beginning with the day after the current bill date and extending to, and including, the next bill date, (2) any known unbilled non-usage sensitive charges for prior periods, (3) unbilled usage sensitive charges for the period beginning with the day after the last bill date and extending up to, and

including, the current bill date unless otherwise agreed between the Parties, (4) any known unbilled usage sensitive charges for prior periods, and (5) any known unbilled adjustments.

[Combinations]

- 2.3 The Bill Date must be present on each bill transmitted by GTE to AT&T. Unbundled Network Element Bills shall not be rendered for any Unbundled Network Element Charges which are incurred under this Agreement on or before one (1) year preceding the Bill Date, except for charges resulting from an audit conducted pursuant to Section 2.1.4 of Attachment 6. In addition, on each bill where "Jurisdiction" is identified, Local Traffic charges shall be identified as "Local" and local toll charges shall be identified as intrastate/intraLATA.

- 2.4 GTE shall bill AT&T for each Element, **or Combination thereof**, supplied by GTE to AT&T pursuant to this Agreement at the rates set forth in this Agreement. GTE will bill AT&T based on the actual Unbundled Network Element Charges incurred, provided, however, for those usage based Unbundled Network Element Charges where actual charge information is not determinable by GTE because the jurisdiction (i.e., interstate, interstate/interLATA, intrastate, intrastate/intraLATA, local) of the traffic is unidentifiable, the Parties will jointly develop a process to determine the appropriate charges. Measurement of usage-based Unbundled Network Element Charges shall be in tenths of conversation seconds. The total conversation seconds per chargeable traffic types will be totalled for the entire monthly bill cycle and then rounded to the next whole minute.

[Combinations]

- 2.5 Costs and expenses incurred in complying with this Attachment shall be calculated and allocated in accordance with Sections 42 and 43 of Part V of this Agreement.

- 2.6 Each Party shall provide the other Party at no additional charge a contact person or center for the handling of any Unbundled Network Element Billing questions or problems that may arise during the implementation and performance of the terms and conditions of this Attachment.

3. **Collocation**

When AT&T collocates with GTE in GTE's facility as described in this Agreement, capital expenditures (e.g., costs associated with building the "cage"), shall be billed separately and shall not be included in the Unbundled

Network Element Bill provided to AT&T pursuant to this Attachment. All such capital expenses shall be given a unique BAN (as defined in Section 2.2.1 of Attachment 6 to this Agreement) and invoice number. All invoices for capital expenses shall be sent to the location specified by AT&T for payment. All other non-capital recurring collocation expenses shall be billed to AT&T in accordance with this Agreement. The applicable CABS Billing Output Specifications ("BOS") documents provide the guidelines on how to bill the Unbundled Network Element Charges associated with collocation. The bill label for those collocation charges shall be entitled "Expanded Interconnection Service." For those nonmechanized Unbundled Network Element bills, the bill label for non-capital recurring collocation expenses shall be entitled "Co-location."

4. **Issuance of Unbundled Network Element Bills - General**

4.1 GTE and AT&T shall issue Unbundled Network Element Bills as follows:

4.1.1 Until the such time as the Parties agree otherwise GTE and AT&T shall issue the information contained in official Unbundled Network Element Bills via EDI.

4.1.2 GTE and AT&T will jointly work together such that on or as soon after July 1, 1999 as possible, GTE and AT&T shall issue the information contained in all official Unbundled Network Element Bills in accordance with the format set forth in CABS BOS Version 28.0, or such later BOS versions that are requested by AT&T and available from GTE at the time of such request and as mutually agreed by the Parties.

4.2 [Intentionally Deleted]

4.3 Each Party will provide the other Party written notice of which Unbundled Network Element Bills are to be deemed the official bills. If either Party requests an additional copy(ies) of a bill, such Party shall pay the other Party a reasonable fee per additional bill copy or transmission, as the case may be, unless such copy or transmission was requested due to errors, omissions, or corrections or the failure of the transmission to comply with the specifications set forth in this Agreement.

4.4 To avoid transmission failures or the receipt of Unbundled Network Element Billing information that cannot be processed, the Parties shall provide each other with their respective process specifications and edit requirements. AT&T shall comply with GTE's processing specifications when AT&T transmits Unbundled Network Element Billing data to GTE. GTE shall comply with AT&T's processing specifications when GTE transmits Unbundled Network Element Billing data to AT&T. AT&T and GTE shall provide each other reasonable notice if a Unbundled Network Element Billing transmission

is received that does not meet such Party's specifications or that such Party cannot process. Such transmission shall be corrected and resubmitted to the other Party, at the resubmitting Party's sole expense, in a form that can be processed. The Payment Due Date for such resubmitted transmissions will be twenty (20) days from the date that the transmission is received in a form that can be processed and that meets the specifications set forth in this Attachment.

5. **Electronic Transmissions of Unbundled Network Element Bills**

[Intentionally Deleted]

5.1 GTE and AT&T agree that on or as soon after July 1, 1999 as possible and following implementation of information delivery via CABS format pursuant to Section 3.1.2 of this Appendix A, each Party will transmit Billing information and data in the appropriate CABS format electronically via Connect: Direct (formerly known as Network Data Mover) to the other Party at the location specified by the Party. The Parties agree that a T1.5 or 56kb circuit to Gateway for Connect: Direct is required. AT&T data centers will be responsible for originating the calls for data transmission via switched 56kb or T1.5 lines. If GTE has an established Connect:Direct link with AT&T, that link can be used for data transmission if the location and applications are the same for the existing link. Otherwise, a new link for data transmission must be established. GTE must provide AT&T/Alpharetta its Connect:Direct Node ID and corresponding VTAM APPL ID before the first transmission of data via Connect:Direct. AT&T's Connect: Direct Node ID is "NDMATTA4" and VTAM APPL ID is "NDMATTA4" and must be included in LEC's Connect:Direct software. AT&T will supply to GTE its RACF ID and password before the first transmission of data via Connect:Direct. Any changes to either Party's Connect: Direct Node ID must be sent to the other Party no later than twenty-one (21) calendar days before the changes take effect.

5.2 The following dataset format shall be used as applicable for those Charges transmitted via Connect:Direct in CABS format:

Production Dataset

AF25.AXXXXYYY.AZZZ.DDDEE	Production Dataset Name
AF25=	Job Naming Convention
AXXXX=	Numeric Company Code
YYY=	LEC Remote
AZZZ=	RAO (Revenue Accounting Office)
DDD=	BDT (Billing Data Tape with or without CSR)
	Or

	CSR (Customer Service Record)
EE=	01 thru 31 (Bill Period) (optional) Or GA (US Postal-State Code)

Test Dataset

AF25.ATEST.AXXXX.DDD	Test Dataset Name
AF25.ATEST=	Job Naming Convention
AXXXX=	Numeric Company Code
DDD=	BDT (Billing Data Tape with or without CSR) Or CSR (Customer Service Record

- 5.2.1 GTE agrees that when it transmits data to AT&T in a mechanized format utilizing CABS, GTE will also comply with the following specifications which are not contained in CABS guidelines but which are necessary for AT&T to process Billing information and data:
- The BAN shall not contain embedded spaces or low values.
 - The Bill Date shall not contain spaces or non-numeric values.
 - Each Bill must contain at least one detail record.
 - Any "From" Date should be less than the associated "Thru" Date and neither date can contain spaces.
 - The Invoice Number must not have embedded spaces or low values.

6. **Testing Requirements**

GTE and AT&T shall adhere to the same testing requirements and specifications for transmitting Unbundled Network Element Bills as applicable to Local Service Bills, as set forth in Appendix A to this Attachment 6, Section 5 and as set forth in Section 5 of this Appendix B.

7. **Local Number Portability**

- 7.1 In accordance with the terms and conditions set forth in this Attachment 6, GTE shall record and provide to AT&T agreed upon detail information associated with a call to an AT&T local exchange customer whose telephone number has been ported from GTE under INP (Interim Number Portability) as further described in the Local Number Portability Attachment to this Agreement.
- 7.2 When an IXC terminates an InterLATA or IntraLATA toll call to an AT&T local exchange customer whose telephone number has been ported from GTE via

INP, the Parties agree that AT&T shall receive compensation for IXC access charges associated with these calls as specified in section 43.3.5 of the Agreement, and Attachment 8 and Attachment 14 to the Agreement. When a call for which access charges are not applicable is terminated to an AT&T local exchange customer whose telephone number has been ported from GTE, the Parties agree that the mutual compensation arrangements described in this Agreement shall apply.

ATTACHMENT 6C

INTERCONNECTION BILLING AND RECORDING

TABLE OF CONTENTS

APPENDIX C 1

INTERCONNECTION BILLING AND RECORDING 1

1. General..... 1

2. Meet Point Billing..... 1

3. Reciprocal Compensation 3

4. Issuance of Meet Point Billing Data and Mutual Billing Data 4

5. Testing Requirements 4

APPENDIX C

INTERCONNECTION BILLING AND RECORDING

1. **General**

This Section describes the Meet Point Billing and Reciprocal Compensation requirements applicable when AT&T is Interconnected to GTE network facilities.

2. **Meet Point Billing**

- 2.1 AT&T and GTE will establish meet-point billing ("MPB") arrangements in accordance with the Meet Point Billing guidelines adopted by and contained in the OBF's MECAB and MECOD documents. Both Parties will use their best reasonable efforts, individually and collectively, to maintain provisions in their respective federal and state access tariffs, and/or provisions within the National Exchange Carrier Association ("NECA") Tariff No. 4, or any successor tariff to reflect the MPB arrangements identified in this Agreement, in MECAB and in MECOD.
- 2.2 AT&T and GTE will implement the "Multiple Bill/Multiple Tariff" option in order to bill any interexchange carrier ("IXC").
- 2.3 GTE and AT&T shall provide to each other the billing name, billing address, and carrier identification code ("CIC") of the IXCs that may utilize any portion of each other's network in an AT&T/ILEC MPB arrangement in order to comply with the MPB Notification process as outlined in the MECAB document. Such information shall be provided to each other in the format and via the medium that the parties agree. If either party does not initially record sufficient bill detail for any IXC for whom either party must supply to the other MPB billing information, each party agrees that it will assist each other in resolving these billing matters by providing sufficient billing detail to the other party to allow that party to obtain reimbursement from the IXC. GTE and AT&T shall require any new IXC to notify both GTE and AT&T using the existing ASR process in accordance with MECOD ordering guidelines.
- 2.4 GTE and AT&T agree that in a MPB arrangement where one Party provides local transport and the other Party provides the end office switching, the Party who provides the end office switching is entitled to bill any residual interconnection charges ("RIC") and common carrier line ("CCL") charges associated with the traffic or such other charges(s) as replace(s), supplements(s) or supersede(s) the RIC and/or the CCL. The Parties further agree that in those MPB situation where one Party sub-tends the other Party's access tandem, the Party providing the access tandem is only entitled to bill

the access tandem fee and any associated local transport charges, as appropriate, and such other applicable charges that are FCC/PSC mandated, tariff specified, or are mutually agreed upon by both GTE and AT&T. The Parties also agree that the Party who provides the end office switching is entitled to bill end office switching fees, local transport charges, RIC and CCL charges, as appropriate, and such other applicable charges that are FCC/PSC mandated, tariff specified, or mutually agreed upon by both GTE and AT&T. The Parties also agree that the Party who provides the end office switching is entitled to bill end office switching fees, local transport charges, RIC and CCL charges or such other charge(s) as replace(s), supplement(s) or supersede(s) the RIC and/or the CCL, as appropriate, and such other applicable charges.

- 2.5 GTE and AT&T will create and transmit MPB information in accordance with the standards and in the format set forth in this Attachment. GTE and AT&T will coordinate and exchange the billing account reference ("BAR") and billing account cross reference ("BACR") numbers for the MPB arrangements described in this Attachment. Each Party will notify the other if the level of billing or other BAR/BACR elements change, resulting in a new BAR/BACR number.
- 2.6 If MPB data is not processed and delivered by either GTE or AT&T and in turn such Party is unable to bill the IXC for the appropriate charges, the Party who failed to deliver the data will be held liable for the amount of the unbillable charges.
- 2.7 If MPB data to be provided in the 1101 call detail records is not submitted within fifteen (15) days of the call date, or if MPB data to be provided in 1150 summary billing records is not submitted within fifteen (15) days of billing the IXC, or if any of the above data is not in the proper format as set forth in this Attachment, and if as a result the other Party is delayed in billing the IXC for the appropriate charges it incurs, the delaying Party shall pay the other Party a late MPB data delivery charge which will be calculated by applying the Late Payment Charge provisions contained in Section 2.4 of Attachment 6 to this Agreement to the appropriate delayed MPB charges.
- 2.8 Errors in MPB data exchanged by the Parties may be discovered by AT&T, GTE or the billable IXC. Both AT&T and GTE agree to provide the other Party with notification of any discovered errors within five (5) business days of the discovery. The other Party shall correct the error for processing current data within fifteen (15) business days of notification and correct and resubmit any prior period data within twenty (20) business days of notification. In the event that the erroneous data cannot be corrected and resubmitted within the time period specified above, the erroneous data shall be considered lost. If MPB data is lost due to incorrecable errors or otherwise, the Parties shall

follow the procedures set forth in the Customer Billing Data Attachment of this Agreement and compensate the other for the lost MPB billing data.

2.9 [Intentionally left blank]

2.10 Neither AT&T nor GTE will charge the other for services rendered, or for information required for Collocation as set forth in this Attachment except those MPB charges specifically set forth herein. Both Parties will provide the other a single point of contact to handle any MPB questions.

3. **Reciprocal Compensation**

3.1 The Parties shall bill each other reciprocal compensation in accordance with the standards set forth in this Agreement for traffic terminated to the other Party's customer, where both such customers bear NPA-NXX designations associated with the same LATA or other authorized area (e.g., extended area service zones in adjacent LATAs), including those traffic types that have been traditionally referred to as "local calling", as "extended area service (EAS)", and as "intraLATA toll". Where GTE is the recording company, such traffic shall be recorded and transmitted to AT&T in accordance with this Attachment. Further, the traffic exchanged pursuant to this Attachment shall be measured in billing minutes of use and shall be in actual conversation seconds. The total conversation seconds per chargeable traffic type will be totaled for the entire monthly billing cycle and then rounded to the next whole conversation minute. Reciprocal compensation for the termination of this traffic shall be charged at rates specified in Part V and Attachment 14.

3.2 In lieu of the reciprocal compensation arrangement described above and where permitted by state law or Commission regulation or order, the Parties may elect in writing to adopt a bill and keep compensation arrangement or such other mutually agreed upon compensation arrangement.

3.3 GTE shall bill AT&T for any Interconnection Service, supplied by GTE to AT&T, pursuant to this Agreement at the rates set forth in this Agreement or as specified in the appropriate Interstate or Intrastate Access Tariff. GTE will bill AT&T based on the actual Interconnection Service Charges incurred, provided, however, for those usage based Interconnection Charges where actual charge information is not determinable by GTE because the jurisdiction, (i.e., interstate, interstate/interLATA, intrastate, intrastate/intraLATA, local) of the traffic is unidentifiable, the Parties will jointly develop a process to determine the appropriate charges.

3.4 AT&T shall bill GTE for any Interconnection Service, supplied by AT&T to GTE, pursuant to this Agreement at the rates set forth in this Agreement or as specified in the appropriate Interstate or Intrastate Access Tariff. AT&T will

bill GTE based on the actual Interconnection Service Charges incurred, provided, however, for those usage based Interconnection Charges where actual charge information is not determinable by AT&T because the jurisdiction, (i.e., interstate, interstate/interLATA, intrastate, intrastate/intraLATA, local) of the traffic is unidentifiable, the Parties will jointly develop a process to determine the appropriate charges.

4. **Issuance of Meet Point Billing Data and Mutual Billing Data**

4.1 GTE and AT&T shall exchange the information and data required to implement Section 2 of this Appendix (i.e. Meet Point Billing information) and Section 3 of this Appendix (i.e. Reciprocal Compensation) in such forms and format as comply with industry standards or as mutually agreed between the Parties. Where feasible, and specifically for EMR format records, this information shall be exchanged via Connect: Direct as provided in Section 2.5 of this Attachment.

5. **Testing Requirements**

The Parties shall adhere to the same testing requirements and specifications for transmitting Meet Point Billing data and Reciprocal Compensation EMR data as applicable to the recording of Call Information as set forth in Section 2.5 of this Attachment. Other forms and formats of data to be exchanged shall adhere to the testing requirements as mutually agreed to by the Parties, or in compliance with appropriate industry standards once they have been developed and implemented by the Parties.

ATTACHMENT 7

PROVISION OF CUSTOMER USAGE DATA

TABLE OF CONTENTS

PROVISION OF CUSTOMER USAGE DATA 1

1. Introduction..... 1

2. General Requirements for Recorded Usage Data..... 1

3. Usage Data Specifications 1

4. Recorded Usage Data Format..... 2

5. Recorded Usage Data Reporting Requirements 3

6. Recording Failures 4

7. Charges..... 5

8. Local Account Maintenance 6

9. Clearinghouse Procedures..... 6

APPENDIX I..... 7

SECTION I: SCOPE 8

SECTION II: RECORDED USAGE TO BE TRANSMITTED TO AT&T..... 9

SECTION III: GTE TO AT&T USAGE FEED 10

SECTION IV: AT&T PROCESSING REQUIREMENTS..... 15

SECTION V: TEST PLANS AND ACTIVITIES..... 17

SECTION VI: POST DEPLOYMENT ACTIVITIES..... 19

SECTION VII: APPENDICES 23

APPENDIX II..... 31

PROVISION OF CUSTOMER USAGE DATA

1. **Introduction**

1.1 This Attachment sets forth the terms and conditions for GTE's provision of recorded usage data (as defined in this Attachment) to AT&T. Recorded Usage Data shall be provided by GTE to AT&T when AT&T purchases Network Elements, **Combinations**, or Local Services from GTE. To the extent sections contained in this Attachment set forth technical references and/or performance standards, GTE's obligation to comply with such references and/or standards shall be subject to Section 23.19 of the General Terms and Conditions of this Agreement.

[Combinations]

2. **General Requirements for Recorded Usage Data**

- 2.1 GTE shall provide AT&T with Recorded Usage Data in accordance with this Attachment.
- 2.2 GTE's provision of Recorded Usage Data to AT&T shall be in accordance with AT&T's Direct Measures of Quality (DMOQs) set forth in Attachment 12.
- 2.3 GTE shall retain Recorded Usage Data in accordance with applicable law and regulation.

3. **Usage Data Specifications**

3.1 To the extent that GTE records such information for itself, GTE will record usage originating from AT&T Customers using the GTE provided Element or Local Services, which include intraLATA toll and local usage. Recorded Usage Data includes, but is not limited to, the following categories of information:

- Call Attempts
- Completed Calls
- Use Of CLASS/LASS/Custom Features
- Calls To Information Providers Reached Via GTE Facilities And Contracted By GTE
- Calls To Directory Assistance Where GTE Provides Such Service To An AT&T Customer
- Calls Completed Via GTE Provided Operator Services Where GTE Provides Such Service To AT&T's Local Service Customer

- For GTE Provided CENTRANET Service, Station Level Detail for calls outside the CENTRANET group
- Records Shall Include Complete Call Detail And Complete Timing Information
- Recording Of Completed Calls Which GTE Does Not Record For Its Own Service Offerings (e.g., Flat Rate Free Calling Area Service)

In the event GTE does not record any one or more of the above information categories, for itself, AT&T may request that GTE record such information. If AT&T requests that GTE record such information and GTE agrees to do so, the Parties shall negotiate the terms and conditions upon which GTE shall deliver such information to AT&T. Nothing in this Agreement shall obligate GTE to record and deliver such information to AT&T.

3.2 GTE shall provide to AT&T Recorded Usage Data for AT&T Customers only in unrated format, except for rated incollects and except as provided in Section 3.3 following. GTE will not submit other carrier local usage data as part of the AT&T Recorded Usage Data.

3.3 Calls to information providers referenced in Section 3.1 preceding shall be provided to AT&T in rated format for billing to the customer.

3.3.1 The parties also agree to establish settlement procedures to permit AT&T to recourse to GTE amounts AT&T Customers refuse to pay for these rated information provider charges forwarded by GTE to AT&T for billing.

3.4 End user customer usage records and station level detail records shall be in packs in accordance with EMR standards.

4. **Recorded Usage Data Format**

4.1 GTE will provide Recorded Usage Data in the EMR format and by category, group and record type, as specified in the AT&T Customer Usage Data Transfer Requirements, March 1996 ("Data Requirements"), which is attached hereto and incorporated herein as Appendix II.

4.2 GTE shall include the Working Telephone Number (WTN) of the call originator on each EMR call record.

4.3 End user customer usage records and station level detail records shall be in packs in accordance with EMR standards.

5. **Recorded Usage Data Reporting Requirements**

- 5.1 GTE shall segregate and organize the Recorded Usage Data in accordance with AT&T's instructions.
- 5.2 GTE shall provide segregated Recorded Usage Data to multiple AT&T biller locations as designated by AT&T.
- 5.3 GTE shall transmit Data Requirements formatted Recorded Usage Data to AT&T via CONNECT:Direct as designated by AT&T. In the event that usage transfer cannot be accommodated by CONNECT: Direct because of extended (one business day or more) facility outages, or if facilities do not exist, the LSP will contract for a courier service to transport the data tapes. Data transported to AT&T on tape or cartridge via a courier will have the physical characteristics indicated in SUBAPPENDIX A. AT&T's intent is for variable block format (2476 bytes) with a LRLECL of 2472. The charge for said service shall be as set forth in Attachment 14.
- 5.3.1 GTE will provide AT&T with contacts for sending/receiving usage files.
- AT&T will provide GTE with contacts responsible for receiving usage transmitted by GTE and usages tapes from a courier service in the event of a facility outage.
- 5.4 AT&T will test and certify the CONNECT:Direct interface to ensure the accurate receipt of Recorded Usage Data. GTE shall make any changes necessary to pass the AT&T CONNECT:Direct certification process.
- 5.5 GTE shall provide Recorded Usage Data to AT&T within the time frames specified in Attachment 12.
- 5.6 GTE will establish a single point of contact to respond to AT&T call usage, data error, and record transmission inquiries.
- 5.7 The Recorded Usage Data EMR format, content, and transmission process will be tested as specified by AT&T.
- 5.8 When requested by AT&T for security purposes, GTE shall provide AT&T with Recorded Usage Data promptly. If not available in EMR format, the Recorded Usage Data may be provided in AMA format.

5.9 USAGE SUMMARY

Messages will be transmitted, via a direct feed, to AT&T in standard EMR format. The following is a list of EMR records that AT&T can expect to receive from the LSP:

Header Record	20-20-01
Trailer Record	20-20-02
Detail Records*	01-01-01, 06, 07, 08, 09, 16, 18, 31, 32, 33, 35, 37, 80, 81, 82, 83, 10-01-01, 06, 07, 08, 09, 16, 18, 31, 32, 35, 37, 80, 81, 82, 83
Credit Records	03-01-XX
Rated Credits	41-01-XX
Cancel Records	51-01-XX
Correction Records	71-01-XX

*Category 01 is utilized for Rated Messages; Category 10 is utilized for Unrated Messages

In addition, the LSP should provide a 42-50-01 Miscellaneous Charge record to support the Special Features Star Services (see Appendix II, Subappendix E for specific details) if these features are part of the LSP's resale product.

For detailed information regarding EMR, refer to the current version of the BellCore Practice BR010-200-010 document.

5.10 AT&T and GTE will track pack number to control input based upon invoice sequencing criteria. GTE will be notified of sequence failures identified by AT&T and resend procedures are to be invoked.

5.11 AT&T, upon receipt of cancel/connection records, will perform their current matching functionality to identify the original message to be connected/cancelled. Processing will be dependent upon individual negotiations.

6. **Recording Failures**

6.1 Loss of Recorded Usage Data - AT&T Recorded Usage Data determined to have been lost, damaged or destroyed as a result of an error or omission by GTE in its performance of the recording function shall, upon AT&T's request, be recovered by GTE at no charge to AT&T. In the event the data cannot be recovered by GTE, GTE shall estimate the messages and associated

revenue, with assistance from AT&T, based upon the method described below. This method will be applied on a consistent basis, subject to modifications agreed to by GTE and AT&T. This estimate will be used to adjust amounts AT&T owes GTE for services GTE provides in conjunction with the provision of Recorded Usage Data.

- 6.1.1 Partial Loss - GTE shall review its daily controls to determine if data has been lost. When there has been a partial loss, actual message and minute volumes shall be reported, if possible. Where actual data are not available, a full day shall be estimated for the recording entity, as outlined in Section 6.1.3 following. The amount of the partial loss is then determined by subtracting the data actually recorded for such day from the estimated total for such day.
- 6.1.2 Complete Loss - Estimated message and minute volumes for each loss consisting of an entire AMA tape or entire data volume due to its loss prior to or during processing, lost after receipt, degaussed before processing, receipt of a blank or unreadable tape, or lost for other causes, shall be reported.
- 6.1.3 Estimated Volumes - From message and minute volume reports for the entity experiencing the loss, GTE shall secure message/minute counts for the four (4) corresponding days of the weeks preceding that in which the loss occurred and compute an average of these volumes. GTE shall apply the appropriate average revenue per message ("ARPM") provided by AT&T to the estimated message volume to arrive at the estimated lost revenue. Within 45 business days of the Effective Date of this Agreement, the Parties will mutually agree on a minimum threshold for application of this Section 6.1.3. Section 6.1.3 will be modified as set forth below:
 - 6.1.3.1 If the day of loss is not a holiday but one (1) (or more) of the preceding corresponding days is a holiday, use additional preceding weeks in order to procure volumes for two (2) non-holidays in the previous two (2) weeks that correspond to the day of the week that is the day of the loss.
 - 6.1.3.2 If the loss occurs on a weekday that is a holiday (except Christmas), GTE shall use volumes from the two (2) preceding Sundays.
 - 6.1.3.3 If the loss occurs on Mother's Day or Christmas, GTE shall use volumes from that day in the preceding year (if available).
- 6.2 AT&T may also request data be provided that has previously been successfully provided by GTE to AT&T. GTE shall provide such data to the extent available subject to AT&T's agreement to pay relevant charges on a case-by-case basis.

7. **Charges**

GTE shall bill and AT&T shall pay the charges set forth in Part V and Attachment 14 for Recorded Usage Data. Billing and payment shall be in accordance with the applicable terms and conditions set forth in this Agreement.

8. **Local Account Maintenance**

- 8.1 When AT&T purchases Local Service from GTE, and, as appropriate, when AT&T purchases certain Unbundled Network Elements, GTE shall provide AT&T with Local Account Maintenance as described in Appendix III of this Attachment. These procedures are in addition to Service Order procedures set forth in Part I and Attachment 4 to this Agreement.

9. **Clearinghouse Procedures**

- 9.1 The Parties acknowledge that calls will be placed using the service of one Party that will be billable to customers of the other Party. In order to ensure that these calls are properly accounted for and billed to the appropriate customer, the Parties agree to work together and, when required, with other carriers, to establish clearinghouse procedures to accomplish these objectives. It is the intention of the Parties that these negotiations will be completed within six (6) months of the Effective Date of this Agreement. These procedures will establish the following:
- 9.1.1 AT&T shall have access to the Bellcore CMDS process for transmitting, receiving, and settling calling card, in-collect, and out-collect inter-region messages.
- 9.1.2 AT&T shall have access to the Bellcore company regional process for receiving and settling calling card, in-collect, and out-collect intra-region messages.
- 9.1.3 In the event a clearinghouse procedure is not in place upon the Effective Date of this Agreement, GTE will implement an interim arrangement with AT&T.

**APPENDIX I
TO
ATTACHMENT 7**

**CUSTOMER USAGE DATA
TRANSFER REQUIREMENTS**

SECTION I: SCOPE

1. General

This Appendix addresses the transmission by GTE of AT&T Customer usage to AT&T.

1.1 Usage Summary

Messages will be transmitted, via a direct feed, to AT&T in standard EMR format. The following is a list of EMR records that AT&T can expect to receive from GTE:

Header Record	20-20-01
Trailer Record	20-20-02
Detail Records*	01-01-01, 06, 07, 08, 09, 16, 18, 31, 32, 33, 35, 37, 80, 81, 82, 83 10-01-01, 06, 07, 08, 09, 16, 18, 31, 32, 35, 37, 80, 81, 82, 83
Credit Records	03-01-XX
Rated Credits	41-01-XX
Cancel Records	51-01-XX
Correction Records	71-01-XX

*Category 01 is utilized for Rated Messages; Category 10 is utilized for Unrated Messages

In addition, GTE shall provide a Miscellaneous Charge 10 01 18 Specialized Service/Service Provider Charge record to support the Special Features Star Services (see Subappendix E for specific details) if these features are part of GTE's offering.

For detailed information regarding EMR, refer to the current version of the BellCore Practice BR010-200-010 Appendix.

2. Appendix Content

This Appendix describes baseline requirements for the transfer of GTE recorded, unrated usage to AT&T. Testing requirements and the reports needed to ensure data integrity are also included. Additional requirements and implementation details may be identified for conditions unique to GTE. Modifications and/or exceptions to this Appendix must be negotiated and mutually agreed upon by GTE and AT&T.

SECTION II: RECORDED USAGE TO BE TRANSMITTED TO AT&T

1. General

This section addresses the types of usage to be transmitted by GTE to AT&T.

9.1 Usage To Be Transferred To AT&T

9.1.1 AT&T Usage To Be Transferred

The following messages recorded by GTE are to be transmitted to AT&T. GTE recorded usage includes all usage by AT&T Customers.

NOTE: Rated incollect messages should be transmitted via the direct feed and can be intermingled with the unrated messages. No special packing is needed.

At the discretion of AT&T, any of the above mentioned messages that cannot be rated and/or billed by AT&T may be returned to GTE via a direct returns feed. Returned messages will be sent to GTE in EMR format. Standard EMR return codes will be utilized.

File transfer specifications are included within Section 3.

9.2 AT&T Usage

The Recorded Usage Data in a local resale environment includes all intraLATA toll and local usage. GTE will provide AT&T with unrated EMR records associated with all intraLATA toll and local usage which they record on AT&T's behalf. Any Category, Group and/or Record types approved in the future for GTE will be included if they fall within the definition of local service resale. AT&T shall be given notification of implementation of a new type within the negotiated timeframes.

NOTE: GTE messages will be packed using the packing criteria outlined in Section 3.4.8. It is important to note that all GTE messages will be packed together (intermingled) based on the appropriate AT&T Send To/Bill To RAO combination. Specific categories, groups, and record types will not be packed separately.

SECTION III: GTE TO AT&T USAGE FEED

1. General

This section contains the information required for GTE to transmit the usage defined in Section II to AT&T. This section specifically addresses the dataset requirements and processing.

9.1 Detailed EMR Record Edits

AT&T will perform detailed record edits on the unrated and rated messages upon receipt from GTE. Messages that fail these edits may be returned to GTE.

9.2 Duplicate Record Checks

AT&T will perform record checks on the unrated and rated messages to validate that duplicate messages are not sent by GTE to AT&T.

9.3 GTE to AT&T Usage Feed

9.3.1 Usage Data Transport Requirements

GTE will provide the transport facility between GTE location and the AT&T location. It is AT&T's intent that usage data be transmitted via CONNECT:Direct whenever possible. In the event usage transfer cannot be accommodated by CONNECT:Direct because of extended (one (1) business day or longer) facility outages, or if facilities do not exist, GTE will contract for a courier service to transport the data via tape.

GTE will provide AT&T with contacts, Remote Identifiers (IDs), and expected usage data volumes for each sending location.

AT&T will provide contacts responsible for:
Receiving usage transmitted by GTE.
Receiving usage tapes from a courier service in the event of a facility outage.

9.3.2 Physical Characteristics

Data transported to AT&T on tape or cartridge via a courier will have the physical characteristics indicated in Subappendix A. AT&T's intent is for variable block format (2,476 bytes) with a LRECL of 2472.

9.3.3 Data Delivery Schedules

Data will be delivered to AT&T by GTE daily (Monday through Friday) unless otherwise negotiated. AT&T and/or GTE Data Center holidays are excluded. GTE and AT&T will exchange schedules of designated Data Center holidays.

9.3.4 Resending Data

AT&T will notify GTE of resend requirements if a pack or entire dataset must be replaced due to pack rejection, damage in transit, dataset name failure, etc.

9.3.5 Pack Rejection

Critical edit failure on the Pack Header or Pack Trailer records will result in pack rejection (e.g., detail record count not equal to grand total included in the pack trailer). Notification of pack rejection will be made by AT&T within one (1) business day of processing. Rejected packs will be corrected by GTE and retransmitted to AT&T by GTE.

9.3.6 Held Packs And Messages

AT&T and GTE will track pack number to control input based upon invoice sequencing criteria. GTE will be notified of sequence failures identified by AT&T and resend procedures are to be invoked.

9.3.7 Data Content Requirements

EMR is the format to be used for usage data provided to AT&T.

9.3.8 RAO Packing Requirements

A pack shall contain a minimum of one message record or a maximum of 9,999 message records plus a pack header record and a pack trailer record. A file transmission contains a maximum of 99 packs. A dataset shall contain a minimum of one pack. GTE will provide AT&T one dataset per sending location, with the agreed upon RAO/OCN populated in the Header and Trailer records.

Within the Header and Trailer records, the FROM RAO identifies the location that will be sending usage to AT&T. GTE will populate the FROM RAO field with the unique numeric value identifying the location that is sending the data to AT&T. GTE will populate the Send To/Bill To RAO fields with the appropriate AT&T RAO values. Also, Pack Header and Trailer will have the OCN appropriately populated.

The FROM RAO, OCN, and Remote Identifiers will be used by AT&T to

control invoice sequencing and each will have its own invoice controls. The FROM RAO will also be used to determine where the message returns file, containing any misdirected and unguidable usage, will be sent.

The file's Record Format (RECFM) will be Variable Block (VB) Size 2,476 and the Logical Record Length (LRECL) will be 2,472 bytes. Compaction requirements can be found in Subappendix B hereto.

AT&T has no special sort requirements for the packs sent by GTE.

9.3.9 Dataset Naming Convention

GTE will transmit the usage to AT&T using the following dataset naming conventions. The dataset name (DSN) will be partitioned into five nodes, separated by periods as follows:

NODE 1*BB03PXNN**

NODE 2.IBMUP

NODE 3 (To be determined during negotiations)

NODE 4.USAGE

NODE 5.*GNNNV00** (Generational Dataset to be incremented by sender).

*The italicized "N" represents numeric fields determined during negotiations.

9.3.10 Control Reports

AT&T accepts input data provided by GTE in EMR format in accordance with the requirements and specifications detailed in this section of the attachment. In order to ensure the overall integrity of the usage being transmitted from GTE to AT&T, data transfer control reports will be required. These reports shall be provided by AT&T to GTE on a daily or otherwise negotiated basis and reflect the results of the processing for each pack transmitted by GTE.

9.3.11 Message Validation Reports

AT&T will provide the following three (3) daily (or otherwise negotiated) Message Validation reports to the designated GTE System Control Coordinator. These reports will be provided for all data received within GTE Local Resale Feed and will be transmitted Monday through Friday whether or not there have been any files transmitted.

9.3.11.1 Message Validation Pack Reject Report (A7287)

This report provides information on packs rejected by AT&T. It lists the

header and trailer record of each rejected pack and indicates the error codes and the associated error message which explains why the pack was rejected.

An example of the report and a list of Valid Error Codes and associated error messages are provided in Subappendix B hereto.

9.3.11.2 Message Validation Pack Accepted Report (A7288)

This report provides vital statistics and control totals by Record ID, Type of Service, Message Counts and Record Counts, for all valid, rejected and dropped messages. The information is provided in the following report formats and control levels:

1. RLEC Total Messages
2. RLEC Total Records
3. RAO Total Messages
4. RAO Total Records
5. Pack Total (Record Counts and Message Counts)

The first four report formats include percentages that indicate the relationship of the daily input volume by Record ID and Type of Record to the total input volume provided by an RAO and GTE.

An example of the report is provided in Subappendix C hereto.

9.3.11.3 Message Validation EMR Detail Error Report (A7289)

An EMR detailed error report is generated for each pack/ invoice that is received and processed by AT&T. The report lists, in vertical format, the complete 175 byte EMR record that has failed to pass the initial edit criteria. It prints this detailed information only for the first five EMR records that share a common error condition. The error condition is flagged on the report by one of two possible error codes preceding the field value. The error codes are:

- (C) DENOTES CRITICAL ERRORS
- (I) DENOTES INFORMATION ERRORS

The last two pages of the report for a given pack/invoice provide the following control totals:

Total Errors for each Field
Total Records Received
Total Records Dropped
Total Records Rejected to MIU

Pack Reject Rate

Total Default Count (represents the number of Files on all of the input records that had to be programmatically altered to meet the EMR standards and specifications.)

If the entire pack/invoice has been rejected because of a Critical Error Rate greater than 0.5%, the last page of the report will display such a statement enclosed in asterisks.

An example of the report is provided in Subappendix D hereto.

9.3.11.4 Control Reports - Distribution

Since GTE is not receiving control reports, dataset names will be established during detailed negotiations.

SECTION IV: AT&T PROCESSING REQUIREMENTS

1. General

This section contains requirements for AT&T processing of Recorded Usage Data that has been transmitted to AT&T for billing.

9.1 AT&T Rating Process

9.1.1 Message Rating

AT&T will rate any individual messages (as defined in Section II), that have not already been rated by GTE (information provider messages will be rated by GTE), prior to transmitting the usage to a billing environment within AT&T.

9.1.2 Application Of Taxes/Fees/Surcharges

AT&T will apply taxes, fees and surcharges as appropriate for the individual messages and/or customer accounts. The application of all taxes, fees and surcharges will be applied on all intraLATA local and toll usage received from GTE.

9.1.3 Duplicate Messages

AT&T has existing duplicate checks as part of their message processing or billing functions. AT&T will perform these checks on the rated/unrated messages sent pursuant to GTE duplicate message disposition procedures and reports will be identified by AT&T during negotiations.

9.1.4 Record Edits

9.1.4.1 AT&T Record Edits

AT&T will perform detailed record edits on the rated and unrated messages prior to transmitting them to the billing environment. Rated and unrated records that do not pass AT&T edits will be returned to GTE.

9.1.4.2 GTE Record Edits

If GTE has existing detailed record edits for rated and unrated messages, GTE is to perform these edits.

Rated and unrated records that do not pass AT&T edits will be returned to GTE. GTE will attempt to perform error correction on all records requiring such action as agreed upon through the detailed negotiations process.

9.1.5 AT&T To GTE Message Returns

At the discretion of AT&T, customer usage data sent to AT&T by GTE that cannot be guided to an AT&T billed account or that cannot be processed will be returned to GTE with the appropriate industry standard return codes.

9.1.6 Cancel/Correction Records

AT&T, upon receipt of cancel/correction records, will perform their current matching functionality to identify the original message to be canceled/corrected. (Processing will be dependent upon individual negotiations.)

SECTION V: TEST PLANS AND ACTIVITIES

1. General

This section defines GTE and AT&T activities which are required prior to implementation. The tests and activities described are necessary to ensure a smooth, accurate and well-programmed conversion. Specific test dates will be identified through the negotiations process.

9.1 Interface Testing

The Parties agree to usage interface testing between GTE and AT&T. The purpose of this test is to ensure that the usage described in Section II preceding can be sent by either Party and can be accepted and processed by the other Party. GTE will provide a test file to AT&T's designated Regional Processing Center (RPC) in the format that will be used for live day-to-day processing. The file will contain one (1) full day's production usage. The format of the file will conform to the requirements shown in Section III. AT&T will review the file and verify that it conforms to its data center requirements. AT&T will notify GTE in writing whether the format is acceptable. AT&T will also provide GTE with the agreed-upon control reports as part of this test.

AT&T will provide a test file to GTE's designated Regional Processing Center (RPC) in the format that will be used for live day-to-day processing. The file will contain one (1) full day's production usage. The format of the file will conform to the requirements shown in Section III. GTE will review the file and verify that it conforms to its data center requirements. GTE will notify AT&T in writing whether the format is acceptable. GTE will also provide AT&T with the agreed-upon control reports as part of this test.

9.2 Operational Test

The purpose of this test is to ensure that volumes of usage in consecutive sequence can be extracted, distributed, and processed by GTE and AT&T.

GTE is required to provide AT&T with GTE recorded, unrated usage (as defined in Section 2) for a minimum of five (5) consecutive days. AT&T will provide GTE with the message validation reports associated with test usage.

AT&T will rate and process the unrated intraLATA toll and local usage. AT&T will process this data to test bills. AT&T may request that the test usage contain specific usage volumes and characteristics to ensure a complete test. Specific usage volumes and characteristics will be discussed during detailed negotiations.

9.3 Test File

Test data should be transported via CONNECT:Direct whenever possible. In the event that courier service must be used to transport test media, the physical tape characteristics to be used are described in Subappendix A hereto.

SECTION VI: POST DEPLOYMENT ACTIVITIES

1. **General**

Requirements for ongoing maintenance of the usage feeds between AT&T and GTE are described in this section. Included are minimal requirements for day to day control of the regularly scheduled transfer of GTE unrated and rated usage data and procedures for introducing and verifying AT&T/GTE System Changes.

9.1 Control Maintenance And Review

9.1.1 Periodic Review

Control procedures for all usage transferred between GTE and AT&T will require periodic review. This review may be included as part of an annual audit of GTE by AT&T or as part of the normal production interface management function. Breakdowns which impact the flow of usage between GTE and AT&T must be identified and jointly resolved as they occur. The resolution may include changes to control procedures, as similar problems would be avoided in the future. Any changes to control procedures would need to be mutually agreed upon by AT&T and GTE.

9.1.2 Retention of Records

Data back-up will be retained for forty-five (45) days. GTE shall maintain a machine readable back-up copy of the message detail provided to AT&T for a minimum of forty-five (45) calendar days. AT&T will maintain the message detail received from GTE for a minimum period of forty-five (45) calendar days. Designated AT&T personnel will provide these records to GTE or its authorized agents upon written request. GTE will also provide any data back to AT&T upon their written request.

9.2 GTE Software Changes

When GTE plans to introduce any software changes which impact the format or content structure of the usage data feed to AT&T, designated GTE personnel will notify AT&T no less than one hundred twenty (120) calendar days before such changes are implemented.

GTE will communicate the projected changes to the appropriate groups in AT&T so that potential impacts on AT&T processing can be determined.

AT&T personnel will review the impact of the change on the entire control

structure as described in Section 1.5, Post Conversion Test Plan, herein. AT&T will negotiate any perceived problems with GTE and will arrange to have the data tested utilizing the modified software.

If it is necessary for GTE to request changes in the schedule, content or format of usage data transmitted to AT&T, GTE will notify AT&T.

9.3 AT&T Requested Changes

If it is necessary for AT&T to request changes in the schedule, content, or format of the usage data transmitted from GTE, AT&T will notify GTE.

When the negotiated changes are to be implemented, AT&T and/or GTE will arrange for testing of the modified data as described in Section 1.5, Post Conversion Test Plan.

9.4 AT&T Software Changes

When AT&T plans to introduce any software changes which may impact the format or content structure of the usage data transmitted from GTE, AT&T will notify the designated GTE personnel, no less than one hundred twenty (120) calendar days before such changes are implemented.

The AT&T contact will communicate the projected changes to the appropriate groups in GTE so that potential impacts on GTE processing can be determined.

AT&T will negotiate any perceived problems with GTE and will arrange to have the data tested utilizing the modified software.

Altering the one hundred twenty (120) day window for introducing software changes can be negotiated by both companies, dependent upon the scope and impact of the change.

9.5 Post-Conversion Test Plan

The test plan described below is designed to encompass all types of changes to the usage data transferred by GTE to AT&T and the methods of transmission for that data.

9.5.1 GTE System Change Description

For a GTE system change, GTE shall provide AT&T with an overall description of the change, stating the objective and a brief explanation of the reasons for the change.

During the initial negotiations regarding the change, GTE shall provide a list of the specific records and/or systems impacted by the change to designated AT&T personnel.

Finally, GTE shall also provide AT&T a detailed description of the changes to be implemented. It shall include sufficient detail for designated AT&T personnel to analyze and estimate the effects of the changes and to design tests to verify the accuracy of the implementation.

9.5.2 Change Negotiations

GTE and AT&T will provide mutual written change notifications. AT&T shall be notified in writing of all proposed change negotiations initiated by GTE. In turn, AT&T will notify GTE of proposed change negotiations initiated by AT&T.

After formal notification of planned changes, whether originated by GTE or AT&T, designated AT&T personnel will schedule negotiation meetings as required with designated GTE personnel. The first meeting should produce the overall change description (if not previously furnished) and the list of records and/or systems affected.

In subsequent meetings, GTE shall provide the detailed description of changes to be implemented. After reviewing the described changes, designated AT&T personnel will negotiate a detailed test procedure with GTE.

9.5.3 Control Change Analysis

Based on the detailed description of the changes provided by GTE, and the review of the projected changes by AT&T, designated AT&T personnel will:

- 9.5.3.1 Determine the impact of the changes on the overall structure.
- 9.5.3.2 Determine whether any single change has a potential control impact (i.e., high error rate on individual records that might result in pack rejection).
- 9.5.3.3 Determine whether any controls might be adversely affected.
- 9.5.3.4 Arrange for appropriate control structure changes to meet any of the above conditions.

9.5.4 Verification Of Changes

Based on the detailed description of changes furnished by GTE, designated AT&T personnel will:

- 9.5.4.1 Determine the type of change(s) to be implemented.
- 9.5.4.2 Develop a comprehensive test plan.
- 9.5.4.3 Negotiate scheduling and transfer of modified data with GTE.
- 9.5.4.4 Negotiate testing of modified data with the appropriate AT&T RPC.
- 9.5.4.5 Negotiate processing of verified data through the AT&T billing system with the RPC.
- 9.5.4.6 Arrange for review and verification of testing with appropriate AT&T groups.
- 9.5.4.7 Arrange for review of modified controls, if applicable.
- 9.5.5 Introduction of Changes

When all the testing requirements have been met and the results reviewed and accepted, designated AT&T personnel will:

- 9.5.5.1 Negotiate an implementation schedule.
- 9.5.5.2 Verify the existence of a contingency plan with the appropriate AT&T personnel.
- 9.5.5.3 Arrange for the follow-up review of changes with appropriate AT&T personnel.
- 9.5.5.4 Arrange for appropriate changes in control program, if applicable.
- 9.5.5.5 Arrange for long-term functional review of impact of changes on the AT&T billing system, i.e., accuracy, timeliness, and completeness.

SECTION VII: SUBAPPENDICES

SUMMARY OF SUBAPPENDICES

Subappendix A

Physical Characteristics Of Data Tapes/
Cartridges

Subappendix B

Message Validation Pack Reject Report (A7287)

Subappendix C

Message Validation Pack Accepted Report (A7288)

Subappendix D

Message Validation EMR Detail Error Report (A7289)

Subappendix E

Special Features Star Services

SUBAPPENDIX A

PHYSICAL CHARACTERISTICS OF DATA TAPES/CARTRIDGES

Data transported to AT&T by GTE, or to GTE by AT&T, on tape or cartridge via a courier will have the following physical characteristics:

Tape:	9-track, 6250 (or 1600) BPI (Bytes per inch)
Cartridge:	38,000 BPI (Bytes per inch)
LRECL:	2,472 Bytes
Parity:	Odd
Character Set:	Extended Binary Coded Decimal Interchange Code (EBCDIC)
External labels:	Exchange Carrier Name, Dataset Name (DSN) and volume serial number
Internal labels:	IBM Industry OS labels will be used. They consist of a single volume label and two sets of header and trailer labels.
One file per sending with variable length records	104 bytes EMR compacted format plus location modules as applicable.

SUBAPPENDIX B (CONT'D)
MESSAGE VALIDATION PACK REJECT REPORT (A7287)

ERROR CODE	ERROR MESSAGES
EC01.2	First record after trailer is not a Pack Header.
EC03.2	From RAO is not numeric.
EC04.3	Invoice number on header invalid.
EC04.5	Company ID not numeric.
EC04.6	Independent company ID is not numeric.
EC04.7	Header Record ID is invalid.
EC04.8	Trailer Record ID is invalid.
EC04.9	Trailer Record count invalid.
EC05.0	Duplicate pack.
EC05.1	Old Pack.
EC05.2	RAO not found on table.
EC07.3	Error rate greater than invoice file threshold for RAO invoice number.
EC12.0	Remote ID in Dataset is not valid.
EC20.0	No detail records in pack.
EC13.0	Invalid status on Pack Header.
EC27.0	Pack exceeds limit of 9,999 detail records.
EC40.9	Pack Header record is missing.
EC41.0	Trailer record is missing.
EC42.0	Trailer message volume is not equal to accumulated message volume.
EC44.0	Header/Trailer date is invalid.
EC45.0	From RAO on Trailer Record is not equal to the from RAO on Header Record.
EC48.0	Invoice number on Trailer Record is not equal to the invoice number on the Header Record.

SUBAPPENDIX C - MESSAGE VALIDATION PACK ACCEPTED REPORT (A7288)

MM/DD/YY-----HH:MM:SS
RETEN CODE: 01R-00300

COMPANY XXXXXXXXXXXXXXXXXXXXXXXXXXXXXXXXXXXX FROM RAO INVOICE NO. DATE CREATED
TOTAL RECORDS RECEIVED

-----999-----99-----MM/DD/YY-----
--ZZ.ZZ9

COUNTS-----MESSAGE COUNTS -----					-----RECORD		
RECORD ID	TYPE OF RECORD				VALID	REJECTED	TOTAL
-DROPPED---TOTAL	VALID	REJECTED	DROPPED	TOTAL	VALID	REJECTED	TOTAL
010102			OUTWATS (NON-SMDR)	ZZ.ZZ9	ZZ.ZZ9	ZZ.ZZ9	
ZZ.ZZ9	ZZ.ZZZ9	ZZ.ZZZ9	ZZ.ZZZ9	ZZ.ZZZ9			
010103			OUTWATS (SMDR)	ZZ.ZZ9	ZZ.ZZ9	ZZ.ZZ9	
ZZ.ZZ9	ZZ.ZZZ9	ZZ.ZZZ9	ZZ.ZZZ9	ZZ.ZZZ9			
010104			800 SERVICE	ZZ.ZZ9	ZZ.ZZ9	ZZ.ZZ9	
ZZ.ZZ9	ZZ.ZZZ9	ZZ.ZZZ9	ZZ.ZZZ9	ZZ.ZZZ9			
	TOTAL WATS/800						
010101			MTS	ZZ.ZZ9	ZZ.ZZ9		
ZZ.ZZ9	ZZ.ZZ9	ZZ.ZZZ9	ZZ.ZZZ9	ZZ.ZZZ9	ZZ.ZZZ9		
010106			NON-DIAL CONFER BRIDGE	ZZ.ZZ9	ZZ.ZZ9	ZZ.ZZ9	
ZZ.ZZ9	ZZ.ZZZ9	ZZ.ZZZ9	ZZ.ZZZ9	ZZ.ZZZ9			
010107			NON-DIAL CONFER LEG RECORD	ZZ.ZZ9	ZZ.ZZ9	ZZ.ZZ9	
ZZ.ZZ9	ZZ.ZZZ9	ZZ.ZZZ9	ZZ.ZZZ9	ZZ.ZZZ9			
010108			DIAL CONFERENCE BRIDGE	ZZ.ZZ9	ZZ.ZZ9	ZZ.ZZ9	
ZZ.ZZ9	ZZ.ZZZ9	ZZ.ZZZ9	ZZ.ZZZ9	ZZ.ZZZ9			
010111			ALLIANCE (AGTC)	ZZ.ZZ9	ZZ.ZZ9	ZZ.ZZ9	
ZZ.ZZ9	ZZ.ZZZ9	ZZ.ZZZ9	ZZ.ZZZ9	ZZ.ZZZ9			

010116					DIAL-IT SERVICE	ZZ.ZZ9	ZZ.ZZ9	ZZ.ZZ9
ZZ.ZZ9	ZZ.ZZZ9	ZZ.ZZZ9	ZZ.ZZZ9	ZZ.ZZZ9				
010132					DIRECTORY ASSISTANCE	ZZ.ZZ9	ZZ.ZZ9	ZZ.ZZ9
ZZ.ZZ9	ZZ.ZZZ9	ZZ.ZZZ9	ZZ.ZZZ9	ZZ.ZZZ9				
010180					MARINE/AIRCRAFT	ZZ.ZZ9	ZZ.ZZ9	ZZ.ZZ9
ZZ.ZZ9	ZZ.ZZZ9	ZZ.ZZZ9	ZZ.ZZZ9	ZZ.ZZZ9				
010181					RADIO LINK	ZZ.ZZ9	ZZ.ZZ9	ZZ.ZZ9
ZZ.ZZ9	ZZ.ZZZ9	ZZ.ZZZ9	ZZ.ZZZ9	ZZ.ZZZ9				
010182					MARINE NON-DIAL CONFER BRIDGE	ZZ.ZZ9	ZZ.ZZ9	ZZ.ZZ9
ZZ.ZZ9	ZZ.ZZZ9	ZZ.ZZZ9	ZZ.ZZZ9	ZZ.ZZZ9				
010183					MARINE NON-DIAL CONFER LEG REC.	ZZ.ZZ9	ZZ.ZZ9	ZZ.ZZ9
ZZ.ZZ9	ZZ.ZZZ9	ZZ.ZZZ9	ZZ.ZZZ9	ZZ.ZZZ9				
0101XX					OTHER MTS RECORDS	ZZ.ZZ9	ZZ.ZZ9	ZZ.ZZ9
ZZ.ZZ9	ZZ.ZZZ9	ZZ.ZZZ9	ZZ.ZZZ9	ZZ.ZZZ9				
TOTAL NORTH AMERICAN MTS								
010201					IOTC/IDDD MTS	ZZ.ZZ9	ZZ.ZZ9	ZZ.ZZ9
ZZ.ZZ9	ZZ.ZZZ9	ZZ.ZZZ9	ZZ.ZZZ9	ZZ.ZZZ9				
0102XX					IOTC/IDDD OTHERS	ZZ.ZZ9	ZZ.ZZ9	ZZ.ZZ9
ZZ.ZZ9	ZZ.ZZZ9	ZZ.ZZZ9	ZZ.ZZZ9	ZZ.ZZZ9				
010301					IOTC BFC MTS	ZZ.ZZ9	ZZ.ZZ9	ZZ.ZZ9
ZZ.ZZ9	ZZ.ZZZ9	ZZ.ZZZ9	ZZ.ZZZ9	ZZ.ZZZ9				
0103XX					IOTC BFC OTHERS	ZZ.ZZ9	ZZ.ZZ9	ZZ.ZZ9
ZZ.ZZ9	ZZ.ZZZ9	ZZ.ZZZ9	ZZ.ZZZ9	ZZ.ZZZ9				
010401					IOC MTS		ZZ.ZZ9	ZZ.ZZ9
ZZ.ZZ9	ZZ.ZZ9	ZZ.ZZZ9	ZZ.ZZZ9	ZZ.ZZZ9	ZZ.ZZZ9			
0104XX					IOC OTHERS	ZZ.ZZ9	ZZ.ZZ9	ZZ.ZZ9
ZZ.ZZ9	ZZ.ZZZ9	ZZ.ZZZ9	ZZ.ZZZ9	ZZ.ZZZ9				
010501					IOC MTS		ZZ.ZZ9	ZZ.ZZ9
ZZ.ZZ9	ZZ.ZZ9	ZZ.ZZZ9	ZZ.ZZZ9	ZZ.ZZZ9	ZZ.ZZZ9			
0105XX					IOC OTHERS	ZZ.ZZ9	ZZ.ZZ9	ZZ.ZZ9
ZZ.ZZ9	ZZ.ZZZ9	ZZ.ZZZ9	ZZ.ZZZ9	ZZ.ZZZ9				
TOTAL OVERSEAS MTS								

015002				OUTWATS LINE SUMMARY	ZZ.ZZ9	ZZ.ZZ9	ZZ.ZZ9
ZZ.ZZ9	ZZ.ZZZ9	ZZ.ZZZ9	ZZ.ZZZ9	ZZ.ZZZ9			
015004				800 LINE SUMMARY	ZZ.ZZ9	ZZ.ZZ9	ZZ.ZZ9
ZZ.ZZ9	ZZ.ZZZ9	ZZ.ZZZ9	ZZ.ZZZ9	ZZ.ZZZ9			
015032				DIR. ASSISTANCE LINE SUMMARY	ZZ.ZZ9	ZZ.ZZ9	ZZ.ZZ9
ZZ.ZZ9	ZZ.ZZZ9	ZZ.ZZZ9	ZZ.ZZZ9	ZZ.ZZZ9			
TOTAL OVERSEAS MTS							
03XXXX				CREDIT REQUESTS	ZZ.ZZ9	ZZ.ZZ9	ZZ.ZZ9
ZZ.ZZ9	ZZ.ZZZ9	ZZ.ZZZ9	ZZ.ZZZ9	ZZ.ZZZ9			
51/52				CANCEL REQUESTS	ZZ.ZZ9	ZZ.ZZ9	ZZ.ZZ9
ZZ.ZZ9	ZZ.ZZZ9	ZZ.ZZZ9	ZZ.ZZZ9	ZZ.ZZZ9			
71/72				CORRECTION REQUESTS	ZZ.ZZ9	ZZ.ZZ9	ZZ.ZZ9
ZZ.ZZ9	ZZ.ZZZ9	ZZ.ZZZ9	ZZ.ZZZ9	ZZ.ZZZ9			
INVALID RECORD IDENTIFICATION				ZZ.ZZ9		ZZ.ZZZ9	ZZ.ZZZ9
ZZ.ZZZ9							
PACK TOTALS			ZZ.ZZ9	ZZ.ZZ9ZZ.ZZ9	ZZ.ZZ9	ZZ.ZZZ9	ZZ.ZZZ9

SUBAPPENDIX D

PAPER COPY OF A REPORT TO BE INCLUDED WITH DISTRIBUTION

SUBAPPENDIX E
SPECIAL FEATURES STAR SERVICES

The following are STAR Services supported by these Local Resale requirements to date. When identified, additional services can be negotiated to be included in this Resale offer.

- 1) Busy Redial/..... This feature allows a customer to redial a number when a Busy signal is encountered.
Last Number Redial
- 2) Call Return/Missed Call Dialing..... This feature allows a customer to automatically return the most recent incoming call, even if it is not answered.
- 3) [Intentionally Deleted]
- 4) Automatic Redial..... This feature allows a customer to automatically redial the last number dialed.

To provide for the transfer and billing of these features the following requirements apply:

For all "per use" STAR Features the 'Specialized Service/Service Provider' 425001 record should be used and be populated as follows:

CONNECT TIME	POSITIONS 55 - 60	MUST BE POPULATED
TEXT CODE	POSITIONS 135 - 139	1) BUSY REDIAL/LAST NUMBER REDIAL POPULATE WITH '00003'
TEXT CODE	POSITIONS 135 - 139	2) CALL RETURN/LAST NUMBER REDIAL POPULATE WITH '00004'
TEXT CODE	[Intentionally Deleted]	3) [Intentionally Deleted]
TEXT CODE	POSITIONS 135-139	4) 3-WAY CALLING POPULATE WITH '00004'
TEXT CODE	POSITIONS 135-139	5) AUTOMATIC REDIAL POPULATE WITH '00003'

NOTE: For fields not specifically defined, the standard EMR format for a 10 01 18 record should be used.

APPENDIX II
TO
ATTACHMENT 7

LOCAL
ACCOUNT MAINTENANCE

LOCAL ACCOUNT MAINTENANCE REQUIREMENTS

1. GENERAL

In a Resale environment the goal is to enable AT&T to create an account maintenance structure congruent to GTE. In the current LEC environment, the LEC has access to all of the customer account data, network switch activity and current status, and new and existing customer account data. In order to obtain the data necessary to satisfy AT&T Local Account Maintenance requirements, GTE must support three key Local Account Maintenance requirements.

1.1 REQUIREMENT #1 - LSP Change Notification Feed

Situation: A Customer initiates a change from AT&T to another LSP by contacting the New LSP. (LSP Change Notification Feed)

GTE shall issue and provide to AT&T at the end of each business day a service activation report in an electronic format reflecting change activity occurring on the previous day.

Create an end-of-day LSP Change Notification Feed:

Purpose: To convey to AT&T that a customer has left the LSP and moved to a new LSP. The new LSP could either be another Reseller, GTE or Facilities based provider.

Data Delivery Schedule: Five days a week, volumes fluctuating with change activity.

Data Transfer Requirements: Batch feed, sent end-of-day, via Connect/Direct NDM sent within 24 hours of the switch being provisioned.

AT&T Data Center Receiving NODE: NDMATTA1

Dataset Name: TMCD.LOCAL.LSPOUT.(+1) = Generation dataset

1.2 REQUIREMENT #2 - LSP SERVICE ORDER PIC ONLY CHANGE PROCESS

Situation: Customer has AT&T for Local Service and contacts AT&T requesting a change of PIC only from one LD Carrier to another.

AT&T Local Process: LD PIC Changes will be accepted by AT&T. AT&T will enter the PIC Change into the service order system, and will generate an LD PIC Change Order which will be sent to GTE for provisioning.

SWP Requirement: Accept a PIC Only Change for an existing AT&T customer via the current Service Order feed. Provision the network, and convey the confirmation of the PIC Only order via the current Work Order Completion feed.

1.3 REQUIREMENT #3 - IXC PIC CHANGE PROCESS

Situation: Customer has AT&T and contacts a New IXC to change PIC to new LD Carrier.

Upon receipt of an IXC-initiated '01' PIC order on a Resold line:

- GTE will reject the '01' order. Create the appropriate Industry Standard '3148', with the Local Service Provider ID of the Reseller and send the reject to the originating IXC. The reject must be returned within one business day.

NOTE: If GTE refuses to provide the Local Service Provider ID the record can be rejected with the Industry Standard transaction code '3147'.

1.4 PIC Restricted

In order for GTE to appropriately reject an IXC initiated "01" PIC Order on an AT&T WTN, GTE must implement a specific up-front edit. Do not apply a 'PIC Freeze' or a 'PIC Restriction'.

If the submitted WTN is a resold line assigned to AT&T (LSP ID 7421), reject the "01" PIC order with TCSI 3148. Populate LSP ID 7421 in the CARE record and return to the submitting IXC. If GTE were to reject the order for the reason of "restricted PIC" rather than "resold line," the submitting IXC would not know the line was resold. This would further delay the IXC's attempt to provision the line with the correct LSP.

The above edit process has nothing to do with "PIC Restriction." It is not AT&T's intent to provide GTE with end user PIC Restriction information since an end user's request for PIC restriction will be resident only on AT&T data bases. IXC initiated PIC orders received by AT&T will be edited for restricted PIC and returned to the submitting IXC with the appropriate reject TCSI if the WTN is found to be restricted.

GLOSSARY OF TERMS

<u>Acronym</u>	<u>Definition</u>
ALEC	Alternate Local Exchange Carrier
CARE	Customer Account Record Exchange
CTI	Customer Type Indicator
Incumbent LEC	Incumbent Local Exchange Company
ISI	Industry Support Interface
IXC	Interexchange Carrier
LAM	Local Account Maintenance
LD	Long Distance
LEC	Local Exchange Company
LERG	Local Exchange Routing Guide
LSP	Local Service Provider
NDM	Network Data Mover
OCN	Operating Company Number
OUTPLOC	LSP CHANGE NOTIFICATION
PIC	Primary Interexchange Carrier
PLOC	Primary Local Operating Carrier
S/O	Service Order
SWP	Switch Provider
WTN	Working Telephone Number

ATTACHMENT 8

INTERIM NUMBER PORTABILITY

TABLE OF CONTENTS

<u>Section</u>	<u>Page</u>
1. PROVISIONING OF INTERIM NUMBER PORTABILITY.....	1
2. INTERIM NUMBER PORTABILITY (INP) METHODS.....	1
3. REQUIREMENTS FOR INP.....	2

INTERIM NUMBER PORTABILITY

1. Provisioning of Interim Number Portability

The Parties shall provide to each other where applicable and to the extent technically feasible, interim number portability (INP) in accordance with the requirements of the Act and FCC 96-286. INP will be provided with minimum impairment of functionality, quality, reliability and convenience to subscribers of AT&T services. INP by Remote Call Forwarding shall be made available for ordering by AT&T upon approval of this Agreement. The Parties agree that the requirements and obligations imposed on GTE under this Attachment 8 and this entire Agreement with respect to number portability shall apply reciprocally to AT&T in locations where number portability from AT&T to GTE is applicable.

- 1.1 In addition, except for the loss of features that may be occasioned by the use of Remote Call Forwarding or other number portability technologies, the AT&T Customer may retain its local telephone number with no loss of features and functionalities; and the post-dial delay (time elapsed between the last digit dialed and the first network response), call completion rate and transmission quality experienced by an AT&T Customer shall be equal in quality to that experienced by a similarly-situated GTE Customer with Remote Call Forwarding or other number portability technology, as the case may be.

2. Interim Number Portability (INP) Methods

2.1 INP Methods

INP shall be provided by Remote Call Forwarding (RCF) or Direct Inward Dialing (DID). AT&T shall specify on a per telephone number basis which method is to be employed and GTE shall provide such method to the extent technically feasible. If DID is ordered but not immediately available, AT&T may choose another available INP method until the requested service is available, provided, however, that GTE shall provide to AT&T the requested service within six (6) months of the approval of this Agreement. AT&T and GTE agree that AT&T may identify additional or revised methods of interim number portability. All such additional or modified methods of interim number portability shall be subject to the Bona Fide Request Procedures outlined in Attachment 12.

2.2 Remote Call Forwarding

Remote Call Forwarding (RCF) is an existing switch-based GTE service that may be used to provide subscribers with limited service-provider LNP by redirecting calls within the telephone network. When RCF is used to

provide LNP, calls to the ported number will first route to the GTE switch to which the ported number was previously assigned. The GTE switch will then forward the call to a number with an NXX associated with the AT&T operated switch to which the number is ported. AT&T shall specify the number of paths required to handle multiple simultaneous calls to the same ported telephone number.

2.3 **Direct Inward Dialing**

When a call to the ported number reaches the GTE switch, DID will route the dialed number directly to AT&T, over end-office to end-office, one-way DID trunking with multi-frequency (MF) signaling for call completion.

2.3.1 DID does not allow for overflow routing. MF signaling does not allow for passing the Calling Party Line Identification (CLID) to AT&T.

2.3.2 [Intentionally Deleted]

2.3.3 GTE shall disclose to AT&T any technical or capacity limitations that would prevent use of a requested INP implementation in a particular switching office. GTE and AT&T shall cooperate in the process of provisioning INP to minimize customer out-of-service time.

3. **Requirements for INP**

3.1 **White and Yellow Page Listings**

GTE shall provide and maintain for AT&T one (1) white page and one (1) yellow page (if applicable) listing for each AT&T subscriber that has ported its number from GTE, consistent with that specified for Provisioning in this Agreement.

3.2 The listing and handling of listed and nonlisted telephone numbers will be at least at parity with that provided by GTE to its own customers.

3.3 **Cutover Process**

GTE shall cooperate in the process of porting numbers from one carrier to the other so as to limit service outage for the ported subscriber.

3.4 **Testing**

GTE shall cooperate in testing ported telephone numbers to assure call completion.

3.5 **Non-Geographic Numbers**

GTE shall not be required to provide number portability for non-geographic services (e.g., 500 and 900 NPAs and 976 NXX number services) under this Agreement.

3.5.1 Compensation arrangements for terminating local traffic between GTE and AT&T shall apply to ported calls.

3.5.2 GTE shall pay to AT&T a portion of the terminating access revenue for calls transported from the interexchange carrier to AT&T via a GTE porting office.

3.6 **Treatment of TLN Calling Cards**

3.6.1 Where Currently Available and where AT&T is purchasing LIDB services from GTE, GTE shall allow AT&T to order provisioning of TLN calling cards and Billed Number Screening (BNS), in its LIDB, for numbers ported on an interim basis, as specified by AT&T. GTE shall continue to allow AT&T access to its LIDB. Other LIDB provisions are specified in this Agreement.

3.7 **911**

AT&T shall have the right to use the existing GTE 911 infrastructure for all 911 capabilities. With respect to 911 service associated with ported numbers under INP, AT&T shall provide to GTE in GTE's capacity as administrator of the PSAP's ALI (Automatic Location Identification) database, current subscriber address records keyed to AT&T's shadow number and including GTE's ported number and GTE's company identification number as established by the National Emergency Number Association (NENA). GTE will provide the AT&T records to the ALI database as promptly as it provides its own records. GTE will work with AT&T to establish a process to verify the accuracy of the information in the PSAP's database.

ATTACHMENT 9

NETWORK SECURITY

TABLE OF CONTENTS

NETWORK SECURITY1

1. Protection of Service and Property.....1

2. Revenue Protection.....2

3. Law Enforcement Interface.....3

4. Impairment of Service4

NETWORK SECURITY

1. Protection of Service and Property

GTE shall exercise the same degree of care to prevent harm or damage to AT&T, its employees, agents or customers, or their property as it employs to protect its own personnel, customers and property, etc. GTE, its employees, agents, or representatives agree to take reasonable and prudent steps to protect AT&T property and services, including, but not limited to:

- 1.1 Restricting access to AT&T's collocation space as set forth in applicable GTE state and federal collocation tariffs. Additionally, GTE agrees that the following terms and conditions shall apply to access to AT&T's collocation space:
 - 1.1.1 GTE shall implement adequate measures to control access to collocation cages.
 - 1.1.2 Collocation space shall comply with all applicable fire and safety codes.
 - 1.1.3 Doors with removable hinges or inadequate strength shall be monitored by an alarm connected to a manned site. All other alarms monitoring AT&T collocation space provided by GTE shall also be connected to a manned site. AT&T may, at its option, provide its own intrusion alarms for its collocated space.
 - 1.1.4 GTE shall control janitorial access to collocation cages, and restrict such access to approved and certified employees, agents or contractors.
 - 1.1.5 GTE shall establish procedures for access to collocation cages by GTE and non-GTE emergency personnel, and shall not allow access by security guards unless such access comports with this section and is otherwise allowed under applicable GTE state and federal collocation tariffs.
 - 1.1.6 GTE shall retain a master key to AT&T's collocation space for use only in event of emergency as detailed in applicable GTE state and federal tariffs. At AT&T's option, the Parties shall review key control procedures no more frequently than twice in any twelve month period. At any time, AT&T may elect to change keys if it suspects key control has been lost, provided, however, that GTE will be provided with a master key in accord with this section.
 - 1.1.7 Not more frequently than twice a year, AT&T may audit the security and access procedures and equipment applicable to its collocated space and the central office housing the collocation space. Access by personnel necessary to conduct such an audit shall be limited as set forth in applicable

GTE state and federal collocation tariffs. Should AT&T identify deficiencies in security and access procedures and equipment, as a result of such audits or otherwise, the cost, terms and conditions of the correction of such deficiencies shall be negotiated in good faith between the Parties.

- 1.2 In order to protect customer proprietary information, ensure both ongoing operational and update integrity of databases, and control access to the ability to disconnect end users on authorized ports, in cases in which there are shared systems access to GTE systems, GTE will provide access controls to its system based upon GTE's internal security standards, which standards shall include, at minimum, traditional log in and password procedures. AT&T shall be responsible for AT&T control installation.

2. **Revenue Protection**

- 2.1 The Parties shall work cooperatively with each other to utilize present and future fraud prevention or revenue protection features, including prevention, detection, or control functionality embedded within the network. These features may include screening codes, call blocking of international, 800, 900/976, and 700 numbers and the capability to require end-user entry of an authorization code for dial tone on a per line basis, in accordance with applicable laws, regulations and tariffs. GTE will provide call blocking of 700 and 800/888 numbers when Currently Available and when made available to GTE end users, in accordance with applicable laws, regulations and tariffs. Upon AT&T's request, GTE shall provide AT&T with information generated by the fraud prevention or revenue prevention features of its network relevant to fraudulent use of services by AT&T's customers.
- 2.2 Uncollectible or unbillable revenues resulting from, but not confined to, provisioning, maintenance, or signal network routing errors shall be the responsibility of the party causing such error.
- 2.3 Uncollectible or unbillable revenues resulting from work errors or software alterations shall be the responsibility of GTE only where it has direct control over the work or software alterations.
- 2.4 The Party that holds legal title to, and the rights to maintain and control the physical integrity of, local loop facilities which are used by the other Party to provide services to its customers, shall be responsible to such other Party for any uncollectible or unbillable revenues resulting from the unauthorised physical attachment to such local loop facilities.
- 2.5 GTE shall provide quick/soft dial tone to allow only the completion of calls to termination points required by law and to establish service.

3. **Law Enforcement Interface**

- 3.1 Only if available in connection with GTE's operation of its own business, GTE shall provide seven day a week/twenty-four hour a day installation and information retrieval pertaining to emergency traps, assistance involving emergency traces and emergency information retrieval on customer invoked CLASS services, including, without limitation, call traces requested by AT&T.
- 3.2 GTE agrees to work jointly with AT&T in security matters to support law enforcement agency requirements for taps, traces, court orders, etc. Charges for providing such services for AT&T Customers will be billed to AT&T.
- 3.3 GTE will, in nonemergency situations, inform the requesting law enforcement agencies that the end-user to be wire tapped, traced, etc. is an AT&T Customer and shall refer them to AT&T.

4. **Impairment of Service**

- 4.1 The characteristics and methods of operation of any circuits, facilities or equipment of either Party connected with the services, facilities or equipment of the other Party pursuant to this Agreement shall not interfere with or impair service over any facilities of the other Party, its affiliated companies, or its connecting and concurring carriers involved in its services, cause damage to their plant, violate any applicable law or regulation regarding the invasion of privacy of any communications carried over the Party's facilities or create hazards to the employees of either Party or to the public (each hereinafter referred to as an "Impairment of Service").
- 4.2 If either Party causes an Impairment in Service, the Party whose network or service is being impaired (the "Impaired Party") shall promptly notify the Party causing the Impairment of Service (the "Impairing Party") of the nature and location of the problem and that, unless promptly rectified, a temporary discontinuance of the use of any circuit, facility or equipment may be required. The Impairing Party and the Impaired Party agree to work together to attempt to promptly resolve the Impairment of Service. If the Impairing Party is unable to promptly remedy the Impairment of Service, then the Impaired Party may at its option temporarily discontinue the use of the affected circuit, facility or equipment.

ATTACHMENT 10**ACRONYMS**

ACRONYM	DEFINITION
AAA	American Arbitration Association
AIN	Advanced Intelligent Network
ALEC	Alternative Local Exchange Carrier
ALI/DMS	Automatic Location Identification/Data Management Systems
AMA	Automated Message Accounting
ANSI	American National Standards Institute
ARPM	Average Revenue Per Message
ATIS	Alliance for Telecom Industry Solutions
ATM	Asynchronous Transfer Mode
BICI	Broadband Inter-Carrier Interface
BITS	Building Integrated Timing Supply
BLV	Busy Line Verification
BRCS	Business and Residential Customer Service
C	Network Element Combination
C-DTTA	Combo of Dedicated Transport & Tandem
C-LPLS	Combo of Loop & Local Switching
C-LSCTSSDBTS	* [Combinations]
CABS	Carrier Access Billing Systems
CAMA ANI	Centralized Automatic Message Accounting - Automatic Number Identification
CAP	Competitive Access Provider
CARE	Customer Account Record Exchange
CCITT	Consultative Committee on International Telegraph & Telephone
CCS	Communications Channel Signaling
CCSNIS	Common Channel Signaling Network Interface Specification
CIC	Carrier Identification Code
CLASS	Custom Local Area Signaling Service
CLC	Carrier Liaison Committee
CLEC	Competitive Local Exchange Carrier
CLLI	Common Language Location Identifier
CMIP	Coded Mark Inversion Protocol

*Combo of: Local Switching, Common Transport, Signaling, Databases & Tandem Switching

CO	Central Office
CPE	Customer Premises Equipment
CRDD	Customer Requested Due Dates
CT	Common Transport
CTI	Customer Type Indicator
CY	Current Year
DA	Directory Assistance
DACS	Digital Access Crossconnect Systems
DB	Database
DB	Service Central Points/Databases
DCC	Data Communications Channel
DCS	Digital Cross-Connect System
DID	Direct Inward Dialing
DLC	Digital Loop Carrier
DLCI	Data Link Connection Identifier
DMOQs	Direct Measures of Quality
DN	Directory Numbers
DN-RI	Directory Number – Route Index
DS-1	Digital Signal Level One
DS-3	Digital Signal Level Three
DS0	Digital Signal Level Zero
DSN	Data Set Name
DSX	Digital Cross Connect
DT	Dedicated Transport
DTMF	Dual-Tone Multi Frequency
E	Network Element
E&M	Ear & Mouth Signaling
E-LP	Element Loop
EAMF	Equal Access Multi-Frequency
EBCDIC	Extended Binary-Coded Decimal Interexchange Code
EBI	Electronic Bonding Interface
EFT	Electronic Fund Transfer
EI	Electronic Interface
EI	Emergency Interrupt
EMR	Exchange Message Record
EO	End Office
ESF	Extended Super Frame
ESL	Essential Service Line
ETTR	Estimated Time to Repair
FDI	Feeder Distribution Interface
FN	Fiber Node
FOC	Firm Order Confirmation
FRF	Frame Relay Forum

FUNI	Framebased User to Network Interface
GTT	Global Title Translation
HDT	Host Digital Terminal
HFC	Hybrid Fiber Coax
HFC-HDT	Hybrid Fiber Coax – Host Digital Terminal
ID	Remote Identifiers
IEC	Interexchange Carrier
IECs	Interexchange Carriers
IEEE	Institute of Electrical and Electronic Engineers
IISP	Interim Interswitch Signaling Protocol
ILEC	Incumbent Local Exchange Carrier
INA	Integrated Network Access
Incumbent LEC	Incumbent Local Exchange Company
INP	Interim Number Portability
ISDN	Integrated Services Digital Network
ISDNUP	Integrated Services Digital Network User Part
ISI	Industry Support Interface
ISNI	Intermediate Signal Network Identifier
ISO	International Standardization Organization
ISUP	Integrated Services User Part
ITU	International Telecommunications Union
IVMS	Interswitch Voice Messaging Service
IXC	Interexchange Carrier
LAM	Local Account Maintenance
LARG	LIDB Access Routing Guide
LASS	Local Area Signaling Services
LATA	Local Access Transport Area
LC	Loop Concentrator/Multiplexor
LCC	Line Class Code
LD	Loop Distribution
LEC	Local Exchange Carrier
LEC DA	LEC Directory Assistance
LEC SCE	LEC Service Creation Environment
LEC SCP	LEC Service Control Point
LEC SMS	LEC Service Management System
LEC SSP	LEC Service Switching Point
LERG	Local Exchange Routing Guide
LF	Loop Feeder
LGX	Lightguide Cross-Connect
LIDB	Line Information Data Base
LMI	Local Management Interface
LNP	Local Number Portability
LP	Loop

LRECL	Logical Record Length
LRN	Local Routing Number
LS	Local Switching
LSO	Local Serving Office
LSP	Local Service Provider
LSSGR	LATA Switching Systems Generic Requirements
MDF	Main Distribution Frame
MDU	Multiple Dwelling Unit
MDU/BCL	Multiple Dwelling Unit/Business Customer Location
MF	Multi-Frequency
MIB	Management Information Base
MLT	Mechanized Loop Tests
MOP	Methods of Procedure
MOS	Modified Operator Services
MR	Modification Request
MRVT	MTP Routing Verification Test
MSAG	Master Street & Address Guide
MTP	Message Transfer Port
NDM	Network Data Mover
NEBS	Network Equipment Building System
NI	Network Interface Device
NID	Network Interface Device
NIU	Network Interface Unit
NMS	Network Management System
NNI	Network to Network Interface
NVT	Network Validation Test
OAM	Operation and Maintenance
OAM&P	Operations Administration Maintenance & Provisioning
OFB	Ordering & Billing Forum
OC	Optical Carrier
OCN	Operating Company Number
ODS	Optical Distribution
OLI	Originating Line Indicator
OMAP	Operations, Maintenance & Administration Part
ORT	Operational Readiness Test
OS	Operator Services
OSPS	Operator Services Position System
OSS	Operations Support Systems
OSSGR	Operator Services Systems Generic Requirements
OUTPLOC	LSP CHANGE NOTIFICATION
PBX	Private Branch Exchange
PDH	Plesiochronous Digital Hierarchy
PEC	Primary Exchange Carrier

PIC	Primary Interexchange Carrier
PLOC	Primary Local Operating Carrier
PNP	Permanent Number Portability
POI	Point of Interface
POI	Points of Interconnection
POT	Point of Termination
POTS	Plain Old Telephone Service
PRI	Primary Rate Interface
PSAP	Public Safety Answering Point
PUC	Public Utilities Commission
RAO	Regional Accounting Office
RCF	Remote Call Forwarding
RECFM	Record Format
RI	Route Index
RI-PH	Route Index - Portability Hub
ROW	Right of Way
RPC	Regional Processing Center
RSM	Remote Switch Module
RT	Remote Terminal
SAG	Street Address Guide
SCCP	Signaling Connection Control Point
SCP	Service Control Points
SDH	Synchronous Digital Hierarchy
SECAB	Small Exchange Carrier Access Billing
SL	Signaling Link Transport
SMDI-E	Standard Message Desk Interface - Enhanced
SMS	Service Management System
SNMP	Simple Network Management Protocol
S/O	Service Order
SONET	Synchronous Optical Network
SPOC	Single Point of Contact
SPOI	Signaling Point of Interconnection
SRVT	SCCP Routing Verification Test
SS	SS7 Message Transfer & Connection Control
SS7	Signaling System 7
SSP	Switching Services Port
STP	Signaling Transfer Point
STS	Synchronous Transport Signal
SWF-DSI	Switched Functional DS1 Service Capability
SWP	Switch Provider
T&M	Time & Material
TCAP	Transaction Capabilities Application Port
TDEV	Time Deviation

TDI	Tie Down Information
TIA/EIA	Telecommunications Industries Association/Electronic Industries Association
TR	Technical Requirements
TS	Tandem Switching
TSG	Trunk Sub-Group
TSGR	Transport System Generic Requirements
TSLRIC	Total Service Long Run Incremental Cost
TSP	Telecommunications Services Priority
UNI	User to Network Interface
VB	Variable Block
VCI	Virtual Channel Identifier
VF	Voice Frequency
WDM	Wavelength Division Multiplexing
WTN	Working Telephone Number

ATTACHMENT 11

DEFINITIONS

“**AAA**” means the American Arbitration Association.

“**Act**” means the Telecommunications Act of 1996.

“**Advanced Intelligent Network (AIN)**” is a network functionality that permits specific conditions to be programmed into a switch which, when met, directs the switch to suspend call processing and to receive special instructions for further call handling instructions in order to enable carriers to offer advanced features and services.

“**Affiliate**” means, with respect to any Party, a corporation or other entity directly or indirectly controlled by, controlling or under common control with such Party. “Control” means the power to direct the management and policies of the entity whether through the ownership of voting securities by agreement, or otherwise.

“**Agreement**” has the meaning set forth in the preamble.

“**AIN Services**” has the meaning set forth in Section 27.1 of the Agreement.

“**AMA**” means the Automated Message Accounting structure inherent in switch technology that initially records telecommunication message information. AMA format is contained in the Automated Message Accounting document, published by Bellcore as GR-1100-CORE which defines the industry standard for message recording.

“**Applicable Law**” shall mean all laws, statutes, common law, regulations, ordinances, codes, rules, guidelines, orders, permits and approvals of any Governmental Authority, including without limitation those relating to the environment, health and safety, which apply or relate to Work Locations or the subject matter of this Agreement.

“**Arbitrator**” has the meaning set forth in Section 6.1 of Attachment 1 of the Agreement.

“**As Defined in the Act**” or “**As Described in the Act**” means as specifically defined or as described, respectively, in the Act as from time to time interpreted in the duly authorized rules and regulations of the FCC or the Commission.

“**AT&T**” has the meaning set forth in the Preface.

"AT&T Customer" means any business or residential customer for AT&T Telecommunications Service.

"Attachment" is any placement of one Party's equipment or facilities in or on another Party's Poles, Ducts, Conduits, or Rights of Way.

"Attachment Request" is a request for attachment made pursuant to Section 3.4 of Attachment 3 of the Agreement.

"Automatic Location Identification/Data Management System (ALI/DMS)" means the emergency services (E911/911) database containing customer location information (including name, address, telephone number, and sometimes special information from the local service provider) used to determine to which Public Safety Answering Point ("PSAP") to route the call.

"Automatic Route Selection (ARS)" is a service feature that provides for automatic selection of the least expensive or most appropriate transmission facility for each call based on criteria programmed into the system.

"Bill" means bill submitted by one Party to the other Party for Charges.

"Bill and Keep" means that either party may track traffic exchanged between the parties but neither party shall bill the other for such traffic and no compensation for such traffic shall be paid from one party to the other.

"Business Day" has the meaning set forth in Section 23.8 of the Agreement.

"BLV/BLI (Busy Line Verify/Busy Line Interrupt) Traffic" or "BLV/BLI Call" means an operator call in which the end user inquires as to the busy status of, or requests an interruption of, a call on an Exchange Service.

"CABS" means the Carrier Access Billing System which is contained in a document prepared under the direction of the Billing Committee of the OBF. The Carrier Access Billing System document is published by Bellcore in Volumes 1, 1A, 2, 3, 3A, 4 and 5 as Special Reports SR-OPT-001868, SR-OPT-001869, SR-OPT-001871, SR-OPT-001872, SR-OPT-001873, SR-OPT-001874, and SR-OPT-001875, respectively, and contains the recommended guidelines for the billing of access and other connectivity services. References to CABS formatted bills and electronic forms of billing data shall be to billing information that is formatted in accordance with applicable CABS guidelines.

"Central Office Switch" means a switch used to provide Telecommunications Services including (I) "End Office Switches" which are Class 5 switches from which end user Exchange Services are directly connected and offered, and

(ii) "Tandem Office Switches" which are Class 4 switches which are used to connect and switch trunk circuits between and among central office switches. Central office switches may be employed as combination end office/tandem office switches (combination Class 5/Class 4).

"**CENTRANET**" means a Telecommunications Service that uses central office switching equipment for call routing to handle direct dialing of calls, and to provide many private branch exchange-like features.

"**Charge**" means an amount charged by one Party to the other Party for services rendered or products purchased hereunder.

"**Claim**" has the meaning set forth in Section 10.4 of the Agreement.

"**CLASS (Custom Local Area Signaling Service) and LASS (Local Area Signaling Service)**" means a grouping of optional enhancements to basic local exchange service that offers special call handling features to residential and single-line business customers (e.g., call waiting, call forwarding and automatic redial).

"**CLEC**" means competitive local exchange carrier.

"**CLLI codes**" means Common Language Location Identifier Codes.

"**CMRS Provider**" means a provider of commercial mobile radio services. CMRS providers are authorized pursuant to 47 U.S.C. Section 332(d)(1) as interpreted by the FCC and the federal courts.

"**Collocation**" has the meaning set forth in Section 2.1 of Attachment 3 of the Agreement.

Combinations has the meaning set forth in Section 1 of the Agreement.

[Combinations]

"**Commission**" means the Michigan Public Service Commission.

"**Common Transport**" has the meaning set forth in Section 7.1 of Attachment 2 of the Agreement.

"**Complaint**" and "**Complaining Party**" have the respective meanings set forth in Section 2(b) of Appendix I to Attachment 1 of the Agreement.

"Conduit" means a tube or protected through that may be used to house communication or electrical cables. Conduit may be underground or above ground (for example, inside buildings) and may contain one or more inner ducts.

"Confidential Information" has the meaning set forth in Section 17.1 of the Agreement.

"Contract Year" means a twelve (12) month period during the term of the contract commencing on the Effective Date and each anniversary thereof.

"Currently Available" means (i) that a service, feature, or functionality exists as part of GTE's network at the time of a requested order or service at the particular location or area where the order is to be fulfilled or the service is to be provided, even if GTE with respect to the service, feature, or functionality does not use or offer such service, feature, or functionality or (ii) that GTE offers a service, feature, or functionality to itself, its affiliates, end-user customers, CLECs or ILECs, at the time of a requested order or service at the particular location or area where the order is to be fulfilled or the service is to be provided. Nothing in this definition or the provisions of this Agreement in which it appears shall be used by AT&T to argue that GTE is required to satisfy any request by AT&T to provide a service, feature, or functionality to the extent such request would constitute a "pick and choose" or a most favored nations election. For purposes of this definition, "location or area" means, for example, a central office, switch, or for transmission equipment, a route or any wire center within an exchange. GTE shall not use "location or area" to restrict availability of a service, feature, or functionality based upon equipment available at or to a specific customer building or site, or an interconnection point. With respect to a particular switch, a feature, functionality or capability of the switch shall be Currently Available in the switch only if such feature, functionality or capability is resident in the switch and GTE has the right to use such feature, functionality or capability. Notwithstanding the above provisions, where GTE is required pursuant to this Agreement to provide a particular service, feature, or functionality where Currently Available, GTE shall not be required to substantially alter its network to accommodate AT&T's requests for superior quality interconnection and/or superior quality access to network elements. GTE will upon request modify its facilities to the extent necessary to accommodate interconnection or access to Network Elements in accordance with footnote 33 of the Eighth Circuit's decision in Iowa Utilities Board v. FCC.

"Customer Usage Data" means the local Telecommunications Services usage data of an AT&T Customer, measured in minutes, sub-minute increments, message units, or otherwise, that is recorded by GTE and forwarded to AT&T.

"DA Listing Information" has the meaning set forth in Section 20.1 of the

Agreement.

“**Damages**” has the meaning set forth in Section 10.4 of the Agreement.

“**Dedicated Transport**” has the meaning set forth in Section 8.1 of Attachment 2 of the Agreement.

“**Directory Listings**” has the meaning set forth in Sections 19.1 and 19.2 of the Agreement.

“**Directory Assistance Service**” has the meaning set forth in Section 6.1 of Attachment 2 of the Agreement.

“**Discloser**” means that Party to this Agreement which has disclosed Confidential Information to the other Party.

“**Disputes**” mean all disputes, claims or disagreements arising under or related to this Agreement or the breach thereof.

“**Duct**” has the meaning set forth in Section 3.1.3 of Attachment 3 of the Agreement.

“**Effective Date**” has the meaning set forth in Section 2 of the Agreement.

“**EMR**” means the Exchange Message Record System used among LECs for exchanging telecommunications message information for billable, non-billable, sample, settlement and study data. EMR format is contained in BR-010-200-010 CRIS Exchange Message Record, published by Bellcore which defines the industry standard for exchange message records.

“**Environmental Hazard**” means any substance the presence, use, transport, abandonment or disposal of which (i) requires investigation, remediation, compensation, fine or penalty under any Applicable Law (including, without limitation, the Comprehensive Environmental Response Compensation and Liability Act, Superfund Amendment and Reauthorization Act, Resource Conservation Recovery Act, the Occupational Safety and Health Act and provisions with similar purposes in applicable foreign, state and local jurisdictions) or (ii) poses risks to human health, safety or the environment (including, without limitation, indoor, outdoor or orbital space environments) and is regulated under any Applicable Law.

“**Enhanced White Pages**” means optional features available for White Pages Directory listings (e.g., bold, all capitals, additional line of text, indented).

"Enhanced Yellow Pages" means optional features available for Yellow Pages Directory listings (e.g., red type, bold, all capitals, additional line of text, indented).

"ESP/ISP Traffic" means traffic bound to any enhanced service provider or Internet service provider as such traffic is referred to in CC-Dockets 96-98 and 99-68. Subject to Appendix 9 to Attachment 14 of this Agreement, ESP/ISP Traffic is not included in Local Traffic.

"Exchange Service" refers to all basic access line services, or any other services offered to end users which provide end users with a telephonic connection to, and a unique telephone number address on, the public switched telecommunications network ("PSTN"), and which enable such end users to place or receive calls to all other stations on the PSTN.

"Excluded Environmental Liabilities" has the meaning set forth in Section 8.1 of the Agreement.

"E911 Service" is a method of routing 911 calls to a PSAP that uses customer location data in the ALI/DMS to determine the PSAP to which a call should be routed.

"Facility" and **"Facilities"** has the meaning set forth in Section 3.1.4 of Attachment 3 of the Agreement.

"FCC" means the Federal Communications Commission.

"Governmental Authority" means any federal, state, local, foreign or international court, government, department, commission, board, bureau, agency, official, or other regulatory, administrative, legislative or judicial authority with jurisdiction over GTE or AT&T.

"Grooming Plan" has the meaning set forth in Section 41.1 of the Agreement.

"GTE" has the meaning set forth in the Preface of this Agreement.

"GTE Customer" means any business or residential customer for GTE Telecommunications Service.

"Impairment in Service", **"Impaired Party"** and **"Impairing Party"** shall have the respective meanings set forth in Section 4 of Attachment 9 of the Agreement.

"Inner Duct" has the meaning set forth in Section 3.1.5 of Attachment 3 of the Agreement.

"Intellectual Property" means copyrights, patents, trademarks, trade secrets, mask works and all other intellectual property rights.

"Intellectual Property Rights" has the meaning set forth in Section 10.4 of the Agreement.

"Inter-Company Review Board" means an inter-company review board established pursuant to Section 3.1 of Attachment 1 of the Agreement.

"Interconnection Services" has the meaning set forth in Section 1 of the Agreement.

"Interim Number Portability (INP)" means the delivery of LNP capabilities, from a customer standpoint in terms of call completion, with as little impairment of functioning, quality, reliability, and convenience as possible and from a carrier standpoint in terms of compensation, through the use of existing and available call routing, forwarding, and addressing capabilities.

"LATA" means local access transport area.

"Line Information Data Base(s) (LIDB)" has the meaning set forth in Section 11.3.1 of Attachment 2 of the Agreement.

"LEC" means local exchange carrier.

"LOA" has the meaning set forth in Section 25.1.1 of the Agreement.

"Local Number Portability (LNP)" means the ability of users of telecommunications services to retain, at the same location, existing telecommunications numbers without impairment of quality, reliability, or convenience when switching from one telecommunications carrier to another.

"Local Services" has the meaning set forth in Section 24 of the Agreement.

"Local Service Bill" means a Bill for Local Service Charges.

"Local Service Charges" has the meaning set forth in Section 2.1 of Appendix A to Attachment 6 of the Agreement.

"Local Traffic" for purposes of interconnection and mutual compensation under this Agreement means traffic: (i) that originates and terminates in the same GTE exchange area; or (ii) originates and terminates in different GTE exchange areas that share a common mandatory local calling area such as mandatory Extended

Area Service (EAS). Local Traffic does not include optional EAS which are those arrangements where the originating end user has a choice between rate plans, one rate plan which does include the identified route and one rate plan which does not include the identified route within the end user's flat-rate calling area. Local Traffic does not include traffic originating from or terminating to CMRS Providers.

“Loop” and **“Loop Combination”** have the respective meanings set forth in Section 3 of Attachment 2 of the Agreement.

“Loop Concentrator/Multiplexer” has the meaning set forth in Section 3.3.1 of Attachment 2 of the Agreement.

“Loop Distribution Media” has the meaning set forth in Section 3.2.1 of Attachment 2 of the Agreement.

“Loop Feeder” has the meaning set forth in Section 3.4.1 of Attachment 2 of the Agreement.

“LSR” means the Local Services request form and processes for ordering services for an end user customer which are approved by the OBF and may be modified by mutual agreement of the Parties.

“Manhole” has the meaning set forth in Section 3.1.7 of Attachment 3 of the Agreement.

“MECAB” means the Multiple Exchange Carrier Access Billing (MECAB) document prepared under the direction of the Billing Committee of the OBF which functions under the auspices of the Carrier Liaison Committee of the Alliance for Telecommunications Industry Solutions. The MECAB document, published by Bellcore as Special Report SR-BDS-000983, contains the recommended guidelines for the billing of access and other connectivity services provided by two or more LECs (including LECs and CLECs), or by one LEC or CLEC in two or more states within a single LATA.

“MECOD” means the Multiple Exchange Carriers Ordering and Design (MECOD) Guidelines for Access Services - Industry Support Interface, a document developed under the auspices of the Billing Committee of the OBF which functions under the auspices of the Carrier Liaison Committee of the Alliance for Telecommunications Industry Solutions. The MECOD document, published by Bellcore as Special Report SR STS-002643, establishes recommended guidelines for processing orders for access and other connectivity services which is to be provided by two or more LECs (including a LEC and a CLEC), or by one LEC or CLEC in two or more states within a single LATA.

"Network Element" or "Element" The term "network element" generally means a facility or equipment used in the provision of a Telecommunications Service. Specific references to the terms "Network Element", "unbundled Network Element", "Unbundled Network Element", "unbundled network element", or "network element", etc., contained in Attachment 2 and throughout this entire Agreement refer to the network elements that are to be unbundled pursuant to Section 32.9 of Part II of this Agreement and any additional network elements that are to be unbundled pursuant to the bona fide request or new service processes set forth in Attachment 12 to this Agreement. Such network elements generally include as applicable, the features, functions, and capabilities that are provided by means of such facility or equipment, including subscriber numbers, databases, signaling systems, and information sufficient for billing and collection or used in the transmission, routing, or other provision of a Telecommunications Service. Portions of this Agreement shall specify the individual features, functions, and capabilities applicable to specific network elements.

"Network Interface Device" or "NID" has the meaning set forth in Section 2.1 of Attachment 2 of the Agreement.

"New Services Request" means a request from AT&T to GTE to obtain facilities, features, capabilities, functionality or services that are not already available under this Agreement.

"North American Numbering Plan" or "NANP" means the numbering plan used in the United States that also serves Canada, Bermuda, Puerto Rico and certain Caribbean Islands. The NANP format is a 10 digit number that consists of a 3 digit NPA code (commonly referred to as the area code), followed by a 3 digit NXX code and a 4 digit line number.

"NXX" means the three digit code which appears as the first three digits of a seven digit telephone number.

"911 Service" means a universal telephone number which gives the public direct access to the PSAP. Basic 911 service collects 911 calls from one or more local exchange switches that serve a geographic area. The calls are then sent to the correct authority designated to receive such calls.

"OBF" means the Ordering and Billing Forum (OBF), which functions under the auspices of the Carrier Liaison Committee (CLC) of the Alliance for Telecommunications Industry Solutions (ATIS).

"Operator Service" has the meaning set forth in Section 5.1.1 of Attachment 2 of the Agreement.

“OSS” means operations support systems.

"Parties" means AT&T and GTE.

"Permanent Number Portability (PNP)" means the use of the Location Routing Number (LRN) database solution to provide fully transparent LNP for all customers and all providers without limitation.

"Pole Attachment" means the connection of a facility to a utility pole. Some examples of facilities are mechanical hardware, grounding and transmission cable, and equipment boxes.

"Public Safety Answering Point" or "PSAP" means an answering location for 911 calls originating in a given area. A PSAP may be designed as Primary or Secondary, which refers to the order in which calls are directed for answering. Primary PSAPs respond first; Secondary PSAPs receive calls on a transfer basis only, and generally serve as a centralized answering location for a particular type of emergency call. PSAP's are staffed by employees of Service Agencies such as police, fire or emergency medical agencies or by employees of a common bureau serving a group of such entities.

"Quality Standards" are referenced in Section 11.3, Sections 9 and 9.4.1 of Attachment 5, and Attachment 12 of the Agreement.

"Real Time" means interactive system-to-system communications and response (of the type described in Section 29.1.2 and Attachment 13) in the actual time in which an event takes place, with the reporting on or recording of the event practically simultaneous (given or assuming network and systems' capabilities) with the occurrence of the event.

"Recipient" means that party to this Agreement to which Confidential Information has been disclosed by the other party.

"Recorded Usage Data" has the meaning set forth in Attachment 7 of the Agreement.

“Remote Call Forwarding” or (“RCF”) has the meaning set forth in Section 2.2 of Attachment 8 of the Agreement.

"Release" means any release, spill, emission, leaking, pumping, injection, deposit, disposal, discharge, dispersal, leaching, or migration, including without limitation, the movement of Environmental Hazards through or in the air, soil, surface water or groundwater, or any action or omission that causes

Environmental Hazards to spread or become more toxic or more expensive to investigate or remediate.

"Right of Way (ROW)" has the meaning set forth in Section 3.1.9 of Attachment 3 of the Agreement.

"SECAB" means the Small Exchange Carrier Access Billing document prepared by the Billing Committee of the OBF. The Small Exchange Carrier Access Billing document, published by Bellcore as Special Report SR OPT - 001856, contains the recommended guidelines for the billing of access and other connectivity services.

"Served Premises" means collectively, all of the locations selected by AT&T for or to which AT&T orders Network Elements or, Ancillary Functions **or** **Combinations**.

[Combinations]

"Signaling Link Transport" has the meaning set forth in Section 9.1 of Attachment 2 of the Agreement.

"Signaling Transfer Points" has the meaning set forth in Section 10.1 of Attachment 2 of the Agreement.

"State" has the meaning set forth in the preamble.

"Structure" has the meaning set forth in Section 3.1.4.1 of Attachment 3 of the Agreement.

"Tandem Switching" has the meaning set forth in Section 12.1 of Attachment 2 of the Agreement.

Telecommunications Service has the meaning set forth in Section 3 of the Act.

"Telephone Relay Service" means a service that enables speech and hearing-impaired callers to type a message into a telephone set equipped with a keypad and message screen and to have a live operator read the message to a recipient and to type message recipient's response to the speech or hearing-impaired caller. This service also works in reverse allowing nonhearing-impaired callers to initiate calls to Telephone Relay Service users.

"TSLRIC" has the meaning set forth in Section 2 of Attachment 14 of the Agreement.

"Thousands Block of Numbers" shall mean 1000 or more consecutive numbers beginning and ending on a digit boundary, e.g., 949-1000 to 949-1999.

"Transit Service" has the meaning set forth in Section 37.5.2 of the Agreement.

"Unbundled Network Element Bill" means a Bill for Unbundled Network Element Charges.

"Unbundled Network Element Charges" has the meaning set forth in Section 2.1 of Appendix B to Attachment 6 of the Agreement.

"Voluntary Federal Customer Financial Assistance Programs" are Telecommunications Services provided to low-income subscribers, pursuant to requirements established by the appropriate state regulatory body.

"Waste" means all hazardous and non-hazardous substances and materials which are intended to be discarded, scrapped, or recycled, associated with activities AT&T or GTE or their respective contractors or agents perform at Work Locations. It shall be presumed that all substances or materials associated with such activities, that are not in use or incorporated into structures (including without limitation damaged components or tools, leftovers, containers, garbage, scrap, residues or byproducts), except for substances and materials that AT&T, GTE or their respective contractors or agents intend to use in their original form in connection with similar activities, are Waste. "Waste" shall not include substances, materials or components incorporated into structures (such as cable routes) even after such components or structure are no longer in current use.

"Wire Center" means a building or space within a building that serves as an aggregation point on a LEC's network, where transmission facilities and circuits are connected or switched.

"Work Locations" means all buildings, equipment, structures and other items located on a single site or contiguous or adjacent sites owned or operated by the same person or persons for the purpose of providing Telecommunications Services in connection with this Agreement.

ATTACHMENT 12
SERVICE QUALITY STANDARDS AND PROCESSES

TABLE OF CONTENTS

1. INTRODUCTION.....	1
2. SERVICE QUALITY	4
3. DEPLOYMENT.....	5
4. PROCESSES	7
5. CAPACITY PLANNING	8

APPENDICES

1. DMOQS
2. DMOQ CATEGORIES
3. AT&T SUPPLIER PERFORMANCE QUALITY MANAGEMENT SYSTEM
4. DEPLOYMENT PLAN
5. BONA FIDE REQUEST PROCESS
6. NEW SERVICES PROCESS

Service Quality Standards and Processes

1. Introduction

This Agreement contains provisions which are applicable to Local Services, Network Elements, including Ancillary Functions and features, **and Combinations**, access to GTE's poles, conduits and rights of way, and Interconnection Services, and shall apply on a national and/or an individual state basis, as herein specified or as otherwise established by agreement of the parties or by the context in which a quality standard, process or measurement is applied. The service quality standards, processes and procedures, including Direct Measures of Quality (DMOQs), set forth in this Attachment shall apply to GTE's provision and performance of services, systems, processes and related activity under this Agreement, and are in addition to and not in place of or satisfaction of specific performance standards or obligations imposed on GTE elsewhere in this Agreement or in other Attachments to this Agreement, provided, however, in no event shall the DMOQ's and corresponding financial incentives set forth in this Attachment require GTE to provide a quality of service higher than that which GTE provides to itself, its affiliates, or other parties to which GTE provides the same or similar services, systems, processes and related activity called for under this Agreement, and in no event shall GTE be required pursuant to this Agreement to pay financial incentives for failure to provide service quality higher than that which GTE provides to itself, its affiliates, or other parties to which GTE provides the same or similar services, systems, processes and related activity called for under this Agreement. To the extent indicated in this Attachment, related performance obligations are imposed on AT&T, and the indicated service quality standards, processes and procedures shall apply to AT&T's performance of said obligations.

[Combinations]

- 1.1. Pursuant to Section 10 of this Agreement, Appendix 1 of this Attachment 12 sets forth the service standards, measurements and performance criteria, applicable to Local Services, and Network Elements (including Ancillary functions and features) **and Combinations** provided under this Agreement, and the liquidated damages, payments, or credits to be paid, or other remedies to apply in the event that specified failures of performance occur.

[Combinations]

- 1.2 The Parties recognize that this Agreement will establish new business processes. The Parties also expect that experience will show whether new

measurements are needed or whether existing measurements are not needed. Either Party, therefore, may request the addition, deletion or modification of the measures set forth in the Appendices to this Attachment. In the event that the Parties cannot agree on such addition, deletion or modification, then the Party seeking the addition, deletion or modification may initiate the Dispute Resolution process prescribed in Attachment 1 to this Agreement.

- 1.3.** GTE shall provide services to AT&T that have substantially the same characteristics of timeliness and performance as GTE provides to itself, its affiliates (hereinafter referred to as "GTE's actual performance"). GTE's service performance, as defined by the designated comparable measures, shall be no worse than or no less than the specific performance threshold of GTE's actual performance for the equivalent service, subject to the definitions contained within this Attachment 12. AT&T shall provide performance as defined by the designated comparable measures at no less than the specific performance thresholds contained within this Attachment 12. The calculation of those performance thresholds will be based on a three (3) month rolling average of actual performance unless otherwise specified. Liquidated damages will apply when a Party's performance is worse than the specified performance threshold as described in this Attachment 12.

1.4 Average Non-Recurring Charges

The Average Non-Recurring Charge is the sum of all non-recurring charges applied to service orders issued by AT&T to GTE divided by the total number of AT&T orders issued to GTE. These calculations will be made by service activity and service category, Business (Single/Multi-Line, Centrex, PBX Trunks), Residence, LINK, and ISDN. The Average Non-Recurring Charge will be separately calculated for field work and non-field work orders. These Averages and a weighting factor for field and non-field work will be calculated during a study period to be mutually agreed between the Parties. The initial average non-recurring charge calculation will occur within three (3) months of AT&T's initial issuance of orders. The average non-recurring charge shall be recalculated when there is a non-recurring charge rate change, and annually as part of the Interconnection Agreement Annual Review.

1.5. Average Recurring Charges

The Average Recurring Charge is the sum of all recurring charges applied to service orders issued by AT&T to GTE divided by the total number of AT&T orders. These Averages will be calculated during a study period to be mutually agreed between the Parties. These calculations will be made by service activity and service category, Business (Single/Multi-Line, Centrex,

PBX, Trunks), Residence, LINK and ISDN. The initial average recurring charge calculation will occur within three (3) months of AT&T's initial issuance of orders. The average recurring charge shall be recalculated when there is a recurring charge rate change, and annually as part of the Interconnection Agreement Annual Review.

1.6 DMOQs are categorized by the Parties as:

CATEGORY 1;
CATEGORY 2; or
CATEGORY 3.

Category 1: Those primary Performance Measures which the Parties agree must be delivered at performance threshold either by state or at a national level or as specified per measure. These DMOQs will carry financial incentives in the form of debits or credits to a Party's bill when a current month's performance is worse than the performance threshold. In addition, gap closure plan incentives will apply to Category 1. (Example: Due Date Commitments Met).

Category 2: Those secondary Performance Measures which are indicators of predicted performance and which the Parties agree must be delivered at or above the performance threshold either at a national level by state as specified in Appendix 2 of Attachment 12. While financial incentives do not apply to these Category 2 DMOQs, gap closure plan financial incentives will apply. (Example: Repair Ticket Closures).

Category 3: Those DMOQs which the Parties may determine to be necessary and appropriate, but which require additional evaluation to permit that determination. The Implementation Team established under this Attachment will review and consider each such Category 3 DMOQ to make the aforementioned determination. If the Implementation Team determines that a Category 3 DMOQ is necessary and appropriate, it will reclassify the DMOQ in question as Category 1 or Category 2.

1.7 The Parties' agreement to these standards, processes and procedures does not waive or limit the rights of either Party to initiate the Dispute Resolution processes provided in Attachment 1 to this Agreement, nor to initiate or pursue other administrative, judicial or arbitration proceedings to enforce rights or obligations under this Agreement or under governing law.

1.8 The service standards, processes and procedures set forth in this Attachment shall not relieve the Parties of any obligations otherwise imposed by the Telecommunications Act of 1996, by the rules, regulations and guidelines duly

promulgated thereunder, or by other applicable state or federal law, nor constitute a waiver by the Parties of any rights relating to such obligations.

- 1.9** As used in this Attachment, Contract Month means a calendar month during the term of this Agreement. Contract Month 1 shall commence on the first day of the first full calendar month following the Effective Date. However, if the Effective Date is on the first day of a Calendar Month, that month will be Contract Month 1.

2. Service Quality

- 2.1** The Parties recognize that this Agreement will establish new business processes. Except for terms and conditions set forth in state specific provisions contained in this Attachment 12 and the procedures and processes developed to address such provisions, it is the objective of the Parties that the terms and conditions of this Attachment 12 as well as the processes and procedures developed under this Attachment 12, shall be interpreted, implemented and applied evenly on a national basis in all applicable circumstances, subject to individual state requirements. The Parties also expect that experience will show whether new measurements are needed or whether existing measurements are not needed. Either Party, therefore, may request the addition, deletion or modification of the measures set forth in the Appendices to this Attachment. The Parties shall work together to resolve such issues promptly and they expect that resolution of such issues shall take into account and reflect industry solutions and experience in addressing similar issues. In the event that the Parties cannot agree on such addition, deletion or modification, then the Party seeking the addition, deletion or modification may initiate the Dispute Resolution process prescribed in Attachment 1 to this Agreement.
- 2.2** DMOQs. GTE will provide Local Service, Network Elements and Ancillary Functions in accordance with the service parity standards and other measurements of quality ("DMOQs") described and agreed to in this Attachment and in the Appendices to this Attachment. In the event that either Party fails to meet an applicable DMOQ, the procedures described in Appendix 1 shall be followed.
- 2.3** Service Guarantees. The credits and waivers described in Appendix 2 are intended to serve as an incentive for the Parties to fulfill certain of their commitments under this Agreement.
- 2.4** AT&T Supplier Performance Quality Management System. As one method of achieving quality and reliability for services ordered from GTE, GTE agrees to implement the AT&T Supplier Performance Quality Management System described in Appendix 3 to this Attachment.

3. Deployment

- 3.1.** Deployment Plan. The Deployment Plan is a staged approach to the implementation of processes, procedures and systems required by this Agreement. The Deployment Plan describes the Parties' attempt to implement a process for attaining performance at or better than the performance threshold.

The Parties agree to implement the provisions of this Agreement in accordance with the Deployment Plan set forth in Appendix 4 to this Attachment. The Parties agree to negotiate, by the end of Contract Month 1, additional requirements which relate to those obligations of the parties in this Agreement that are not addressed in the Deployment Plan.

Thereafter, the Deployment Plan may be revised from time to time to add any additional requirements established by the Parties as part of the implementation process.

- 3.2.** Implementation Team.

The Parties understand that the arrangements and provision of services, network elements and ancillary functions described in this Agreement shall require technical and operational coordination between the Parties. The Parties further agree that it is not feasible for this Agreement to set forth each of the applicable and necessary procedures, guidelines, specifications and standards that will promote the Parties' provision of Telecommunications Services to their respective Customers. Accordingly, the Parties agree to form a team (the "Implementation Team") which shall develop and identify those additional processes, guidelines, specifications, standards, terms and conditions necessary for the provision of the services, network elements and ancillary functions, and for the specific implementation of each Party's obligations hereunder, including those described in the Deployment Plan. Within five (5) days after the Effective Date, each Party shall designate, in writing, not more than four (4) persons to be permanent members of the Implementation Team; provided that either Party may include in meetings or activities such technical specialists or other individuals as may be reasonably required to address a specific task, matter or subject. Each Party may replace its representatives on the Implementation Team by delivering written notice thereof to the other Party. Furthermore, the Deployment Plan will describe the Parties' attempt to implement a process for attaining and maintaining service parity.

3.3. Operations Plan.

Within one hundred and twenty (120) days after the Effective Date, the Implementation Team shall reach agreements on the items listed in the Deployment Plan, which shall include processes, procedures, and milestones. The agreements reached by the Implementation Team shall be documented in an operations manual (the "Operations Plan"). The Operations Plan shall include documentation of the various items described in the agreement which are to be agreed upon by the Parties.

3.4. Action of Implementation Team.

The Deployment Plan and the Operations Plan may be amended from time to time by the Implementation Team as the team deems appropriate. Unanimous written consent of the permanent members of the Implementation Team shall be required for any action of the Implementation Team. An escalation process will be put in place to support the resolution of disputed issues. If the Implementation Team and the escalation process are unable to resolve the issue, the existing provisions of the Deployment Plan and Operations Plan shall remain in full force and effect.

3.5. Further Coordination and Performance.

Except as otherwise agreed upon by the Parties, on a mutually agreed upon day and time once a month during the Term of this Agreement, the Implementation Team shall discuss the performance of the Parties under this Agreement and apply the principles of the AT&T Supplier Performance Quality Management System. At each such monthly session the Parties will discuss: (i) the administration and maintenance of the interconnections and trunk groups provisioned under this Agreement; (ii) the Parties' provisioning of the services, network elements and ancillary functions provided under this Agreement; (iii) the Parties' compliance with the DMOQs set forth in this Agreement and any areas in which such performance may be improved; (iv) any problems that were encountered during the preceding month or anticipated in the upcoming month; (v) the reason underlying any such problem and the effect, if any, that such problem had, has or may have on the performance of the Parties; and (vi) the specific steps taken or proposed to be taken to remedy such problem. In addition to the foregoing, the Parties, through their representatives on the Implementation Team or such other appropriate representatives, will meet to discuss any matters that relate to the performance of this Agreement, as may be requested from time to time by either of the Parties.

3.6. Operational Review

3.6.1. Representatives of AT&T and GTE will meet on a quarterly basis, beginning with the end of the first quarter of 1997, to determine that the service cycle of pre-ordering, ordering, provisioning, maintenance and billing categories are addressed, including the following:

a) Interfaces and processes are operational and the agreed upon numbers of AT&T Customers for residential and business Resale Services are successfully completed per day;

b) Interfaces and processes are operational and the agreed upon numbers of orders for Network Elements, and Ancillary Functions **and Combinations** are successfully completed per day;

[Combinations]

c) Interfaces and processes are operational and the AT&T orders for unbundled loops are successfully completed per day;

d) All agreed upon performance standards and DMOQs will be reviewed with respect to the Implementation Plan.

3.6.2. If at any quarterly review it is determined that the requirements of this Agreement and the Act are not being met, the Parties may invoke the dispute resolution proceedings provided in Attachment 1 to this Agreement where allowed by applicable regulatory orders.

4. Processes

The Parties agree to implement the following processes as a means to provide a mechanism for addressing the individual requirements of AT&T in a specific state.

4.1. The Bona Fide Request process set forth in Appendix 5 to this Attachment 12 is to be used when AT&T requests customized Service Orders for certain services, features, capabilities or functionality defined and agreed-upon by the Parties as services to be ordered as Bona Fide Requests. The Parties agree to apply effective FCC regulations, the Act, and other applicable law to the determination of whether GTE will offer any Network Elements in addition to those listed in Section 32.9 of the Agreement.

- 4.2. New Services. AT&T may request from GTE that facilities, features, capabilities, functionality or services that are not already available under this Agreement at the time of such request be provided under this Agreement by delivering a New Services Request to GTE in accordance with the procedures described in Appendix 6 to this Attachment.

5. **Capacity Planning**

- 5.1 The Parties negotiated and included in this Agreement common provisions which are applicable to Local Services, Network Elements, including Ancillary Functions and features, **and Combinations**, access to GTE's poles, conduits and rights of way, and Interconnection Services for all geographic areas in which GTE provides Telecommunications Services on a national basis. However, the Parties recognize that certain provisions, in addition to pricing, must be handled on a state specific basis to address unique local requirements. These items are described below in this Attachment.

[Combinations]

- 5.1.1 By the end of Contract Month 1, AT&T will provide a forecast of the quantities of Local Services, Network Elements, **Combinations** and Ancillary Functions to be made available to AT&T during Contract Year 1 on a State-wide basis. The Parties shall meet during the last Contract Month of each Contract Year to agree upon the quantities of Local Services, Network Elements, **Combinations** and Ancillary Functions to be made available to AT&T for the next Contract Year. These quantities shall be sufficient to meet AT&T's anticipated requirements as communicated to GTE. If GTE is not able to meet AT&T's forecast requirements at any time during the term of this Agreement, GTE must document to AT&T within fifteen (15) days of receiving AT&T's forecast the reasons why such requirements cannot be met.

[Combinations]

- 5.2 In addition, AT&T will furnish a per month quarterly forecast of service order volumes, quantities of Local Services, Network Elements, **Combinations** and Ancillary Functions on a State-wide basis. These forecasts will be furnished at least one month before the beginning of the quarter covered by the forecast. These projections will allow GTE to provide sufficient Staff for the projected demand and to secure appropriate inventories to meet AT&T's requirements. In the event that the first month of AT&T's next quarterly forecast is greater than ten (10%) percent of the last month of the current quarter forecast, AT&T will notify GTE promptly of the increased order volume.

[Combinations]

- 5.3** If AT&T actual order activity for a quarter is ten (10%) percent less than stated in its forecast submission to GTE for that quarter, then financial incentives as set forth in Appendix 2 will apply. If AT&T actual order activity for a quarter exceeds the level stated in its forecast submission to GTE for that quarter pursuant to Section 5.2 of this Attachment 12, then as to such order activity in excess of forecast levels, the remedies otherwise applicable for missed service order commitments in the Category 1 and Category 2 DMOQs and preparation of Gap Closure Plans shall not apply.
- 5.4** AT&T will provide forecasts as specified in Sections 5.1 and 5.2 on a sub-State basis, provided, however, that AT&T will provide such forecasts only after the Parties have mutually agreed on a definition of "sub-State" and further provided, that no penalties shall apply to sub-State forecasts.
- 5.5** At the meeting to be held during the last Contract Month of each Contract Year, AT&T will provide GTE with a two (2) year rolling forecast of its growth requirements for Ancillary Functions that will be reviewed jointly on a yearly basis.

**Appendix 1
to
Attachment 12**

DMOQs

1. **General**

The DMOQs in this Appendix are managed as part of the Supplier Performance Quality Management System (SPQMS).

SPQMS requires that when the monthly results do not meet the performance levels described in Appendix 2 to this Attachment, Gap Closure Plans shall be implemented to improve performance. The intent of a Gap Closure Plan is to identify and implement expeditiously those actions necessary to close performance gaps to the acceptable levels of performance established by the Parties under this Agreement and this Attachment. The Parties anticipate that Gap Closure Plans will typically be of six to nine months' duration.

These Gap Closure Plans include:

- evaluation of the opportunity for continuous improvement, systems enhancements and re-engineering;
- forecasted improvement to the desired DMOQ for each issue or initiative;
- evaluation of pertinent changes in periodic results; and
- a date for compliance with AT&T's expected performance.

The Gap Closure Plans will be reviewed monthly, or more frequently as updated data and analysis are available.

2. **Measurements**

The specific measurements which apply to this Agreement are described in Appendix 2. The Parties agree to meet on an annual basis to discuss whether changes should be made to any DMOQs or performance objectives.

3. **Performance Incentives**

- 3.1. If either Party fails to meet an applicable Category 1 or 2 DMOQ for Three (3) Contract Months in a Six (6) Month period, that Party must thereafter submit

to the other Party a draft of a Gap Closure Plan within thirty (30) days of receipt of notice that the DMOQ(s) was (were) not met.

- 3.2. If either Party required under Section 3.1 preceding to deliver a draft Gap Closure Plan to the other Party fails or fails within the prescribed time period to do so, then the other Party shall receive a credit or payment of Five Thousand Dollars (\$5,000.00). Said payment or credit shall be made within three (3) business days of the entitled Party's demand therefor.
- 3.3. AT&T and GTE will agree upon an approval date for the Gap Closure Plan within ten (10) days of the delivery of the draft Gap Closure Plan.
- 3.4. The Party subject to the Gap Closure Plan will commence implementation of the Gap Closure Plan on its approval date. If that Party fails to meet its commitments under the Gap Closure Plan, the other Party shall receive a credit or payment, as appropriate, in the sum of up to Fifteen Thousand dollars (\$15,000) payable on demand within three (3) business days, as described in Sections 3.4.1, 3.4.2 and 3.4.3 below.
 - 3.4.1 Payment of Five Thousand Dollars (\$5,000) for failure to implement the process improvements outlined in the plan. The parties may with mutual agreement modify the process improvements in the plan during the life of the plan.
 - 3.4.2 Payment of Five Thousand Dollars (\$5,000) for failure to achieve performance improvements by the completion date of the approved Gap Closure Plan.
 - 3.4.3 Payment of Five Thousand Dollars (\$5,000) for failure to complete the Gap Closure Plan on schedule.
- 3.5 GTE is committed to service parity at the start of AT&T's Local Service operations. Both parties recognize that a sufficient volume of orders must be processed before a DMOQ can exhibit with a degree of confidence that parity does or does not exist.

The Parties agree to a "transition period" where process data will be accumulated and discussed. This information will assist the Implementation Team in their development and implementation of processes.

For national DMOQs, once AT&T's order volume reaches a level of one hundred fifty (150) orders for three (3) consecutive months, a ninety (90) day grace period will begin, with respect to the performance incentives prescribed

for each DMOQ under this Attachment. At the end of that ninety (90) day grace period, those performance incentives shall fully apply.

For State DMOQs, once AT&T's order volume reaches a level of one hundred fifty (150) orders for the State for three (3) consecutive months, a ninety (90) day grace period will begin, with respect to the performance incentives prescribed for each DMOQ under this Attachment. At the end of that ninety (90) day grace period, those performance incentives shall fully apply.

- 3.6** The purpose of the payments described above are to serve as an incentive for the Parties to improve their respective performance, not as a substitute for either Party's right to institute dispute resolution processes under Attachment 1 of this Agreement.

Appendix 2
to
Attachment 12
DMOQ Categories

1. Category 1 DMOQs
 - 1.1 Table 1 below lists the Category 1 DMOQs for each of the pre-ordering, ordering and provisioning, interconnection, maintenance and repair, forecasting, and billing classifications. For each Category 1 DMOQ classification, column 1 indicates the number of the DMOQ within the classification. Column 2 indicates which Party has the obligation to meet the DMOQ performance measurement, with a "G" indicating a GTE obligation and an "A" indicating an AT&T obligation. Column 3 indicates whether the relevant DMOQ performance measurement data is compiled on a national level ("N"), by state ("S"), or by each occurrence of the DMOQ ("P"). Column 4 contains a description of each DMOQ within each classification. Column 5 describes, for each DMOQ, the performance measurement that applies to the DMOQ. Column 6 shows the remedy that must be paid by the Party that has the obligation to meet the DMOQ if that Party has failed to meet the performance thresholds set forth in column 5.
 - 1.2. The Parties agree to provide performance at or above the performance thresholds for each applicable DMOQ as indicated in Table 1 following. Each Party also agrees to pay to the other Party the remedies applicable to each DMOQ for which it has an obligation to meet the performance thresholds but has failed to do so.

TABLE 1
CATEGORY 1 DMOQs

			DESCRIPTION	MEASURE	REMEDY
			Pre-Ordering/Ordering/Provisioning		
1	G	N	Prompt transmission of Customer Service Record ("CSR") Information	85% of CSRs sent to AT&T by the close of business on business day following receipt of request.	5% of Average Non-Recurring Charges incurred by AT&T for the number of CSRs for which the Quality Standard is not met in the reported month.
2	G	N	Prompt transmission of Firm Order Confirmation ("FOC")	85% of FOCs sent to AT&T by the close of business on business day following receipt of request.	20% of Average Non-Recurring Charges incurred by AT&T for the lines ordered for which GTE failed to meet the Quality Standard in the reported month.
3	G	S	Due Date commitments met	Percent of AT&T Customer install, transfer and change service orders for which service is installed by close of business on the committed due date is not more than 2.5 percent below the percent of GTE customer install, transfer and change service orders.	Waiver of the Average Non-Recurring Charges installation charges for the number of lines by which GTE fails to meet the Quality Standard in the reported month.

			DESCRIPTION	MEASURE	REMEDY
4	G	S	% Reporting trouble within 30 days of the date installed	Percent of AT&T customer install, transfer and change service orders which are followed by a customer trouble report within 30 days of service order completion date is not more than 2.5 percent worse than the percent GTE customer install, transfer and change service orders which are followed by a customer trouble report within 30 days of service order completion date.	One month's average recurring charge per trouble report exceeding the Quality Standard in the reported month. (not to exceed one credit per customer line per month).
5	A	S	Service Order Discrepancy: LSRs issued without material errors.	80 percent of LSRs initiated by AT&T do not contain an order discrepancy or error. Twelve (12) months after this measurement becomes effective, the metric shall change to 90 percent.	Payment by AT&T to GTE equal to 20% of the average non-recurring installation charges for the number of lines by which AT&T fails to meet the Quality Standard in the reported month.
6	G	N	PIC Changes completed within 72 hours (or at parity with what GTE provides to itself or any other party, which ever is shorter.)	85% of the time the PIC changes will be completed within 72 hours (or at parity with what GTE provides to itself or any other party, which ever is shorter.) .	PIC change charge credit for all PIC changes worse than the quality standard.
			Interconnection		
1	G	S	Trunk orders completed on or before the Committed	Percent of trunk orders by AT&T completed by GTE on or before the commitment date is not more than 10 percent below the percent of	Waiver of 100% of Average Non-Recurring Charges for trunks ordered

			DESCRIPTION	MEASURE	REMEDY
			Due Date.	feature group B & D switched access orders by all ordering companies completed by GTE on or before the commitment date.	for which GTE failed to meet the Quality Standard in the reported month.
2	G	N	Firm Order Confirmation (FOC) time delivery	Percent of trunk orders by AT&T completed by GTE on or before the commitment date is not more than 5 percent below the percent of feature group B & D switched access orders by all ordering companies for which GTE sends FOC within 5 days.	Waiver of 20% of Average Non-Recurring installation charges for trunks ordered for which GTE failed to meet the Quality Standard in the reported month.
3	A	N	Service Order Discrepancy: ASRs issued without material errors.	80% of ASRs initiated by AT&T do not contain a material error or result in a discrepancy. Twelve (12) months after this measurement becomes effective, the metric shall change to 90 percent.	Charge equal to 20% of Average Non-Recurring Charges for installation of trunks ordered for which AT&T failed to meet the Quality Standard in the reported month.
4	G	P	Collocation: Conditioning of space provided for Collocation.	The time AT&T's collocated space is not available to AT&T for installation of equipment by the agreed upon due date.	The credit will be calculated by dividing the monthly recurring charge for such collocated space by 30, times the number of days delayed. This penalty does not apply if the delay circumstances are

			DESCRIPTION	MEASURE	REMEDY
					beyond GTE's control.
5	G	P	Collocation: Outage of AT&T Equipment Collocated in GTE space.	The time AT&T's collocated equipment is out of service due to GTE's failure to comply with its obligations under this agreement.	AT&T will receive an outage credit calculated by dividing the monthly recurring charge for such collocated space by 30, times the number of days of outage. This penalty does not apply if the delay circumstances are beyond GTE's control.
6	G	P	Rights of Way (ROW), Conduit and Pole Attachments Availability.	When ROW, Conduit and Pole-Attachments are not available to AT&T by the agreed upon due date.	AT&T will receive a credit in the amount proportionate to the length of the delay. The credit will be calculated by dividing the annual rental charge by 365 times the number of days delayed. This penalty does not apply if the delay circumstances are beyond GTE's control.
			Maintenance/Repair		

			DESCRIPTION	MEASURE	REMEDY
1	G	S	Percent commitments met.	Percent of AT&T customer network trouble reports where commitment met was more than 2.5 percent worse than the percent of GTE customer network trouble reports where commitment was met (excluding reports which are cleared CPE, AT&T Customer error).	One month's flat rate average recurring charge per line out of service for which Quality Standard is not met in the reported month.
2	G	S	Average clearing time - out of service - Designed.	Average repair time (total number of elapsed hours/minutes for out of service AT&T Customer network trouble reports divided by total number out of service customer network trouble reports) for AT&T Customers is more than 10 percent more than the average repair time for GTE Customers (includes only "designed" services).	One month's flat rate average recurring charge per line out of service for which Quality Standard is not met in the reported month.
3	G	S	Average clearing time - out of service - non-designed	Average repair time (total number of elapsed hours/minutes for out of service customer network trouble reports divided by total number out of service customer network trouble reports) for AT&T Customers is more than 10 percent more than the average repair time for GTE customers (includes only POTS and circuits which do not require a design).	One month's flat rate average recurring charge per line out of service for which Quality Standard is not met in the reported month.
4	G	S	Percent reports per 100 (failure frequency)	Percent of AT&T Customers making trouble reports (total number of AT&T Customer network trouble reports divided by the total access lines multiplied by 100) is not worse than 0.5 percentage points than the percent of GTE customers making	One month's flat rate average recurring charge per line out of service for which Quality Standard is not met in the

			DESCRIPTION	MEASURE	REMEDY
				trouble reports.	reported month.
5	G	S	Percent repeat reports in 30 days	Percent of AT&T Customer repeat trouble reports (total number of AT&T Customer network trouble reports which had a previous network trouble report within the last 30 days divided by the total number of customer network trouble reports multiplied by 100) is not more than 2.5 percent worse than the percent of GTE customer repeat trouble reports.	One month's flat rate average recurring charge per line out of service for which Quality Standard is not met in the reported month.
			Forecasting		
1	A	S	Resale requirements accurately forecast.	Volume of AT&T's resale requirements in a month is not greater than 10% below the amount forecast by AT&T in its most recent quarterly forecast (which shall have been made not later than 30 days prior to the quarter in question.)	20 percent of the Average Non-Recurring Charges for the number of service units below the forecast when the actual volume is greater than 10% and less than or equal to 30% under forecast. 40 percent of the Average Non-Recurring Charges for the number of service units below the forecast when the actual volume is greater than 30% and less than or equal to 40%

			DESCRIPTION	MEASURE	REMEDY
					under forecast. 50 percent of the Average Non-Recurring Charges for the number of service units below the forecast when the actual volume is over 40% under the forecast.
			Billing		
1	G	N	Advance notification of late billing associated with the wholesale bill.	GTE agrees to develop, within six months of the Effective Date, a Quality Standard for the percent of notifications received by AT&T prior to late billing based upon a mutually agreed upon financially significant threshold. The documentation provided prior to late billing must include: 1) the anticipated bill date and 2) a reasonably accurate estimate of the adjustment or charge.	GTE will credit AT&T's national resale bill by \$5,000 per month for each month in which commitment is not met.
2	G	N	Timeliness: Delivery of mechanized Customer Service Record (CSR) for wholesale billing verification.	GTE agrees to make by March 30, 1997, an initial assessment of its capability to measure the percent of CSRs received within 10 days of the actual bill date. The Implementation Team will determine the appropriate percent of CSRs to be delivered on time.	GTE will credit AT&T's national resale bill by \$5,000 per month for each month in which commitment is not met.

1.3. Outage Credits

1.3.1 Local Services and, Network Elements **and Combinations**: Outage credits apply to interruptions of Local Services or, Network Elements **or Combinations**, in accordance with applicable state Public Service Commission requirements.

[Combinations]

1.3.1.1 If a Local Service or, Network Element **or Combination** is interrupted, AT&T will be entitled to outage credits. An interruption period begins when AT&T reports to GTE that a Local Service or, Network **Element or Combination** is interrupted (or GTE has knowledge that an interruption has occurred through service monitoring or other means). An interruption period ends when the Local Service or, Network Element **or Combination** is repaired and returned to AT&T. A Local Service or, Network Element **or Combination** is considered to be interrupted when there has been a loss of continuity, the Local Service or, Network Element **or Combination** does not operate in accordance with the applicable service standards, or it is otherwise unavailable for use by AT&T. This definition is not intended to conflict with state Public Utility Commission requirements.

[Combinations]

1.3.1.2 The Implementation Team will evaluate if and set the amount of outage credits for unbundled Network Elements **and Combinations** and determine when they should apply.

[Combinations]

2. Category 2 DMOQs

2.1 Table 2 below lists the Category 2 DMOQs for each of the pre-ordering, maintenance, and billing classifications. For each Category 2 DMOQ classification, column 1 indicates the number of the DMOQ within the classification. Column 2 indicates which Party has the obligation to meet the DMOQ performance measurement, with a "G" indicating a GTE obligation and an "A" indicating an AT&T obligation. Column 3 indicates whether the relevant DMOQ performance measurement data is compiled on a national level ("N"), by state ("S"), or by each occurrence of the DMOQ ("P"). Column 4 contains a description of each DMOQ within each classification. Column 5 describes, for each DMOQ, the performance measurement that applies to the DMOQ.

2.2 The Parties agree to provide performance at or above the performance thresholds for each applicable DMOQ as indicated in Table 2 following.

TABLE 2
CATEGORY 2 DMOQs

			DESCRIPTION	MEASURE
			Pre-Ordering/Ordering/Provisioning	
1	G	N	Average speed of answer per inquiry by GTE's call center within 20 seconds.	80% of the time GTE will answer within 20 seconds
			Maintenance	
1	G	S	Average speed of answer per inquiry by GTE's call center within 20 seconds	80% of the time GTE will answer within 20 seconds.
			Billing	
1	G	N	Timeliness: Charges billed in current wholesale billing period for	GTE agrees to make, by March 30, 1997, an initial assessment of its capability to measure the percent of dollar amount due

			flat rated services.	for service orders billed in the current billing period in which the service order was completed and provide such assessment to AT&T so the Parties can agree on and establish performance thresholds.
2	G	N	Timeliness: Charges billed within 90 days for usage charges.	GTE agrees to make, by March 30, 1997, an initial assessment of its capability to measure the percent of dollar amount due for usage charges billed within 90 days from the date the service was rendered and provide such assessment to AT&T so the Parties can agree on and establish performance thresholds.
3	G	N	Accuracy: Financial accuracy of local OCC bills. Financial accuracy is the percent of total net dollars correctly billed.	GTE agrees to make, by March 30, 1997, an initial assessment of its capability to measure the percent of total net dollars accurately billed, excluding bill correcting adjustments resulting from AT&T's inaccurate LSRs, and provide such assessment to AT&T so the Parties can agree on and establish performance thresholds.
4	G	N	Timeliness: Making corrections and adjustments within agreed timeframes.	GTE agrees to make, by March 30, 1997, an initial assessment of its capability to measure the percent of all corrections and adjustments made within agreed timeframes and provide such assessment to AT&T so the Parties can agree on and establish performance threshold.
5	G	N	Customer Usage Data: File Transfer: GTE will initiate and transmit all files error free and without loss of signal.	Meets Expectations: 6 months of file transfers without a failure. Note: During the first 6 months after the Effective Date.
6	G	N	Customer Usage Data: Timeliness: Delivery of all messages delivered within 5 days of when the message	GTE's initial service performance threshold will be 94% of all messages delivered within 5 days from when the message was recorded. GTE agrees to make, by March

			was recorded.	30, 1997, an initial assessment as to what a parity level of performance should be. Within six months of the contract Effective Date, the Parties will agree on an ongoing performance measure and associated penalties.
8	G	N	Customer Usage Data: Accuracy of transmitted customer usage data.	An initial service delivery threshold will be established at 99% of recorded usage data correctly transmitted to AT&T. GTE agrees to make, by March 30, 1997 an initial assessment as to what a parity level of performance should be. Within six months of the contract effective date, the Parties will agree on an ongoing performance measure and associated penalties.

3. Category 3 DMOQs

3.1 Table 3 below lists the Category 3 DMOQs for each of the pre-ordering, ordering and provisioning, maintenance, and billing classifications. For each Category 3 DMOQ classification, column 1 indicates the number of the DMOQ within the classification. Column 2 indicates which Party may have the obligation to meet the DMOQ performance measurement, with a "G" indicating a potential GTE obligation, an "A" indicating a potential AT&T obligation and "T" indicating the party is to be determined. Column 3 indicates whether the relevant DMOQ performance measurement data might be compiled on a national level ("N"), by state ("S"), or by each occurrence of the DMOQ ("P"). Column 4 contains a description of each DMOQ within each classification.

3.2 The Parties agree to form an Implementation Team pursuant to Section 3.2 of Attachment 12, to consider and determine whether each Category 3 DMOQ shall be reclassified as a Category 1 or Category 2 DMOQ or should be removed as a Category 3 DMOQ without reclassification. If the Implementation Team agrees to reclassify a Category 3 DMOQ as either a Category 1 or Category 2 DMOQ, the Implementation Team will also establish a performance threshold and performance remedies for that DMOQ. The Implementation Team will set a schedule for considering and determining any such reclassifications under this Paragraph no later than six months after the Effective Date of this Agreement.

TABLE 3
CATEGORY 3 DMOQs

			DESCRIPTION
			Pre-Ordering/Ordering/Provisioning
1	A	N	Service Order Discrepancy: LSRs issued without material errors. The Implementation Team will evaluate and produce a plan to migrate from the 90% performance threshold to the 95% target performance threshold.
2	G	N	Real Time Solution: Tracks the time required to receive one or more telephone numbers via a system interface. The interval starts with the request message leaving AT&T's system and ends with the response message arriving at AT&T's system. The DMOQ tracks the percentage of intervals that are less than 5 seconds.

			DESCRIPTION
3	T	N	Real Time Solution: Tracks the time required to receive address confirmation information via a system interface.
4	T	N	Real Time Solution: Service Availability Inquiry Time.
5	T	N	Real Time Solution: Feature Availability Inquiry Time
6	T	N	Real Time Solution: Appointment Schedule Inquiry Time.
7	T	N	Real Time Solution: Customer Service Record (CSR) Inquiry Time.
8	T	N	Disconnect Order Completion Interval. Measures how long it takes to complete a disconnect. Residence: within twenty-four (24) hours after acceptance of a service order. Business: Within four (4) hours after acceptance of a service order if a software change is required. Business: Within twenty-four (24) hours after acceptance of a service order if a central office change is required. Business: Within ninety-six (96) hours after acceptance of a service order if a customer premises visit is required.
9	T	N	Installation line energizing commitments (request for establishment or changes in non-key, non-PBX and party line services that normally involve plant activity).
10	G	N	PIC Migration: Measures the percent of migration notifications sent to AT&T within forty-eight (48) hours of receipt of the migration order. As a measurement of performance standards, this metric will comply with the specific performance level shown below. Measurements will be calculated by Business (single and multi-line, Centrex, PBX trunks), Residence, LINK and ISDN.
11	G	N	Directory Assistance: Tracks the levels of Directory Assistance performance levels for resold services and unbundled network elements.
12	G	N	GTE shall provide LIDB performance standards. AT&T will specify expectations of performance such as 1) at least 99.9% reply rate to all query attempts; 2) Data in LIDB replies shall have at no more than 2% unexpected data value, for all inquiries.
13	A	S	Forecasting. Implementation Teams will work together to define sub-state forecasting levels. The Parties agree that no penalties shall apply to any sub-state levels that may be defined by the Implementation Team.
			Maintenance

			DESCRIPTION
1	G	S	Quoted restoral commitments met.
2	G	S	Status Call to AT&T: when restoral commitments are missed, on trouble progress, or on restoration.
3	T	S	Network event with blocked calls or lost features within one hour.
4	G	S	Time to Restore <ul style="list-style-type: none"> - Out of Service & Visit Required at 4, 8, or 16 hours after initial outage. - Out of Service & No Visit required at 2, 3, or 4 hours after initial outage. - All Other Troubles at twenty-four (24) hours after initial outage.
			Billing
1	G	N	Timeliness: GTE will mechanically transmit, via Connect: Direct, all usage records to AT&T's Message Processing Center three times per day at expected performance threshold of 99.94% of all messages delivered on the day the call was recorded.
2	G	N	Accuracy: GTE will provide Recorded Usage Data in the format and with the content as defined in the current Bellcore EMR document of expected performance threshold of 99.99% of all recorded records delivered.
3	G	N	DATA PACKS: GTE will transmit to AT&T all data packs error free in the format agreed at an expected performance threshold of 6 months of transmitted data packs without a rejected data pack.
4	G	N	Accuracy: Recorded Usage Data: GTE will ensure that the Recorded Usage Data is transmitted to AT&T error free, the level of detail includes but is not limited to: detail required to rate the call, Duration, and Correct Originating/Terminating information. The error is reported to GTE as a Modification Request (MR). Performance is to be measured at 2 levels defined below. AT&T will identify the priority of the MR at the time of handoff as Severity 1 or Severity 2 at expected performance threshold of less than or equal to 99% of the MR fixed in less than or equal to twenty-four (24) hours and 100% of the MR fixed in less than or equal to 5 days.

			DESCRIPTION
5	G	N	Usage Inquiry Responsiveness: GTE will respond to all usage inquiries within twenty-four (24) hours of AT&T's request for information. It is AT&T's expectation to receive continuous status reports until the request for information is satisfied.
6	G	N	Business and Residence Mechanized wholesale bills adhere to specifications in the (Local Services Billing System e.g. CABS, BOS, SAIR, CRIS, etc.) specifications/requirements document. Accurate bills are those mechanized access bills which pass AT&T's validation edit process the first time at expected performance threshold of less than or equal to 99.5%.
7	T	N	Business and Residence: Billing Period Closure agreements are signed within the agreed timeframe (typically 60 to 90 days) at expected performance threshold of 100% per agreed timeframe.

**Appendix 3
to
Attachment 12**

AT&T Supplier Performance Quality Management System

AT&T's approach to quality and reliability focuses on the attainment of excellence for products and services ordered from its suppliers and used by AT&T. This excellence is the result of a systematic effort that is sustained over time.

1. Quality Manual

By the end of Contract Month 4, GTE will develop a Quality Manual that addresses the requirements described herein for the following :

- Management Responsibility and Support
- Quality System
- Document Control
- Process Control
- Product Development Control
- Alignment of Process Output with Agreed-to Requirements
- Identification of Non-conforming Product or Service
- Analysis of the Identified Non-conformance
- Corrective Action Plans
- Quality Records
- Audits and Reviews
- Training

The Quality Manual will be updated by GTE from time to time as additional process are identified. The Quality Manual and its revisions are subject to review and approval by AT&T.

2. Process Ownership

For each process identified in the Quality Manual, GTE will identify those individuals and organizations who have management responsibilities for each process which affects services to be provided to AT&T by GTE.

The initial individuals and organizations will be identified by GTE by the end of Contract Month 1. GTE shall provide prompt updates to AT&T of changes in personnel, organization or linkages.

3. Process Definition

For each process included in the Quality Manual, the following items will be addressed:

- a) input requirements;
- b) value-added process functionality; and
- c) output requirements which meet customer satisfaction

4. Measurement System

The Quality Manual will define the Measurement System to be used to obtain the data necessary to verify that DMOQs have been met, and to provide data needed to perform source cause and root cause analyses.

Changes to the agreed upon Measurement System must be reviewed with and concurred by AT&T prior to their implementation. GTE will review metrics on a monthly basis with AT&T and will be available for review and analysis, as mutually agreed to be necessary, for all services. Measures shall be AT&T specific and support AT&T service performance requirements.

5. Improvement Plan Implementation

GTE will establish monthly service performance and improvement reviews with AT&T.

Documentation will include Gap Closure Plans which result in compliance with agreed to performance standards and include:

- a) evaluation of the opportunity for continuous improvement, systems enhancements and re-engineering;
- b) forecasted improvement to the desired Direct Measure of Quality (DMOQ) for each issue or initiative;
- c) current and improved upon processes;
- d) control processes which GTE management will use for the transitional period;
- e) evaluation of pertinent changes in periodic (monthly, weekly) results;
- f) opportunities for source and root cause analyses; and
- g) a date for compliance with Gap Closure Plans implementation.

These Gap Closure plans will be reviewed monthly or, more frequently as updated data and analyses are available.

6. AT&T Leadership Reviews

GTE Senior Leadership shall meet with AT&T on at least a quarterly basis. GTE shall assure that resources are provided within GTE to support implementation of the Supplier Quality Performance Management Program.

7. Integration of AT&T Requirements

GTE will integrate the techniques of the Supplier Quality Performance Management Program described in this Appendix 3 in all aspects of the work that it performs on AT&T's behalf.

**Appendix 4
to
Attachment 12**

Deployment Plan

1. Deployment Plan Activities:

The Parties agree to complete the activities applicable to them no later than the times indicated for said completion on the following Table:

CONTRACT MONTH*	ACTIVITY
Effective Date	Final agreement on DMOQs and Service Guarantees.
Month 1	<ol style="list-style-type: none"> 1. Identification of individuals and organizations with management responsibilities (the Implementation Team) as described in Appendix 3 to Attachment 12. 2. Agreement on Supplier Performance Quality Management System (SPQMS), Deployment Plan, activities, Milestones, and Implementation Schedule. 3. Capacity planning for Contract Year 1 completed as described in Section 7 to Attachment 12. 4. Agreement on escalation and expedite procedures as described in Section 30.2.2 of the Agreement. 5. GTE furnishes a list of all emergency telephone numbers as described in Section 28.8 of the Agreement. 6. Appointment of a standing arbitrator as described in Attachment 1.
Month 2	<ol style="list-style-type: none"> 1. Identification of single points of contact as described in and within Section 30 of the Agreement, Section 13 of Attachment 2, Sections 3 and 4 of Attachment 3, Section 2 of Attachment 4, Section 9 of Attachment 5, Section 2 of Attachment 6C, Section 5 of Attachment 7. and other Agreement or Attachment sections in this Agreement providing for such single points of contact. 2. GTE proposes the process for handling requests for new services, features and/or capabilities as described in Section 4.2 of Attachment 12.

* Unless indicated to be a specific date.

Month 3	1. Agreement on the procedures to handle law enforcement agency requests as described in Section 28.11 of this Agreement.
Month 4	1. Quarterly SLT Review of SPQMS with GTE. 2. Development of Quality Manual as described in Appendix 3 to Attachment 12.
Month 5	1. GTE will finalize the process for handling requests for new services, features and/or capabilities as described in Section 4.2 of Attachment 12. 2. Finalize Operations Plan as provided in Section 3.3 of Attachment 12.
Month 7	1. Quarterly SLT Review of SPQMS with GTE.
Month 10	1. Quarterly SLT Review of SPQMS with GTE.
Month 11	1. Annual Review of Performance Results Gap Closure plans per SPQMS. 2. Annual Capacity Planning for Contract Year 2 is completed as described in Section 7 to Attachment 12.

2. The Parties agree to negotiate by the end of Contract Month 4, additional requirements and milestones which relate to those obligations of GTE in this Agreement that are not addressed in the Deployment Plan, including, but not limited to, the implementation of the following:
- Electronic Interfaces as described in Section 29.1 of the Agreement and Section 5.1 of Attachment 4.
 - Alternative Routing Capabilities as described in Section 28 of the Agreement.
 - Service and Operational Readiness Testing as described in Attachment 29.8 of the Agreement.
 - Alternative Interim Agreement for Local Service bills as described in Section 3 of Attachment 6A.
 - Procedures for notifying AT&T of changes in retail services as described in Section 25.6 of the Agreement.
 - Procedures for referring misdirected requests for AT&T products and services as described in Section 29.3 of the Agreement.
 - Customer contact training as described in Section 29.6.6 of the Agreement.
 - Procedures for referrals of misdirected calls for repair as described in Section 8 of Attachment 5.
 - Replication of Access Billing Supplier Quality Certification Operating Agreement as described in Section 2.1.2 of Attachment 6.
 - Interim arrangements for clearinghouse procedures as described in Section 9 of Attachment 7.

- Disaster recovery plans as described in Section 7 of Attachment 5.
- Route Indexing (RI) as described in Section 2.3 of Attachment 8.

- Processes for service ordering and provisioning of Local Services, and Network Elements **and Combinations**.
- Processes for maintenance of Local Services, and Network Elements **and Combinations**.

[Combinations]

**Appendix 5
to
Attachment 12**

Bona Fide Request Process

1. Intent

The Bona Fide Request process is intended to be used when AT&T requests customized Service Orders for certain services, features, capabilities or functionality defined and agreed-upon by the Parties as services to be ordered as Bona Fide Requests.

2. Process

- 2.1 A Bona Fide Request shall be submitted in writing by AT&T and shall specifically identify the need to include technical requirements, space requirements and/or other such specifications that clearly define the request such that GTE has sufficient information to analyze and prepare a response.
- 2.2 Although not expected to do so, AT&T may cancel a Bona Fide Request in writing at any time prior to AT&T and GTE agreeing to price and availability. GTE will then cease analysis of the request.
- 2.3 Within two (2) business days of its receipt, GTE shall acknowledge in writing the receipt of the Bona Fide Request and identify a single point of contact and any additional information needed to process the request.
- 2.4 Except under extraordinary circumstances, within ten (10) days of its receipt of a Bona Fide Request, GTE shall provide a proposed price and availability date, or it will provide a detailed explanation as to why GTE is not able to meet AT&T's request. If extraordinary circumstances prevail, GTE will inform AT&T as soon as it realizes that it cannot meet the ten (10) day response due date. AT&T and GTE will then determine a mutually agreeable date for receipt of the request.
- 2.5 Unless AT&T agrees otherwise, all proposed prices shall be consistent with the pricing principles of the Act, FCC and/or the Commission. Payments for services purchased under a Bona Fide Request will be made upon delivery, unless otherwise agreed to by AT&T, in accordance with the applicable provisions of the Agreement.

- 2.6 Upon affirmative response from GTE, AT&T will submit in writing its acceptance or rejection of GTE's proposal. If at any time an agreement cannot be reached as to the terms and conditions or price of the request, the Dispute resolution procedures described in Attachment 1 may be used by a Party to reach a resolution.

- 2.7 If GTE responds that it cannot or will not offer the requested item in the Bona Fide Request and AT&T deems the item essential to its business operations, and deems GTE's position to be inconsistent with the Act, FCC or Commission regulations and/or the requirements of this Agreement, the Dispute resolution procedures described in Attachment 1 may be used by a Party to reach a resolution.

**Appendix 6
to
Attachment 12**

New Services Process

The Parties shall work cooperatively to establish a New Services Process with the objective of having this process in place within six (6) months following approval of this Agreement.

This process shall include consideration of the following principles:

- 1) AT&T will implement the process by submitting a request to GTE that defines the new services, features and/or capabilities in sufficient detail to permit GTE to analyze the request and prepare a preliminary response.
- 2) As part of the preliminary response, GTE will advise AT&T whether or not the request is technically feasible. If the requested service, feature and/or functionality is technically feasible, GTE will advise AT&T whether or not it is prepared to proceed with development and, if so, furnish a preliminary price estimate for the service, feature and/or functionality.
- 3) Upon affirmative response from GTE, AT&T will submit in writing its acceptance or rejection of GTE's proposal. If at any time an agreement cannot be reached as to the terms and conditions or price of the request, the Dispute resolution procedures described in Attachment 1 may be used by a Party to reach a resolution.
- 4) AT&T and GTE will jointly participate in the development of the new service, feature and/or functionality, using an agreed upon implementation plan.
- 5) Payments for the new service, feature and/or functionality will be made upon delivery, unless otherwise agreed to by AT&T, in accordance with the applicable provisions of the Agreement.
- 6) If GTE responds that it cannot or will not offer the requested service, feature and/or functionality and AT&T deems the item essential to its business operations, and deems GTE's position to be inconsistent with the Act, FCC or Commission regulations and/or the requirements of this Agreement, AT&T may use the Dispute resolution procedures described in Attachment 1 to reach a resolution.

ATTACHMENT 13

[This entire Attachment is Intentionally Deleted]

Attachment 14

AT&T/GTE Pricing Agreement

TABLE OF CONTENTS

1. LOCAL SERVICE RESALE1
2. UNBUNDLED NETWORK ELEMENTS1
3. COLLOCATION1
4. INTERCONNECTION SERVICES1
5. OTHER.....2

Appendix 1 - Local Service Resale

Appendix 1 - Annex 1 - Schedule of Wholesale Discounts

Appendix 1 - Annex 2 - Summary of Wholesale Charges

Appendix 2 - Prices for Unbundled Network Elements
Michigan (Per Order)

Appendix 3 - Prices for Collocation

Appendix 3 - Annex 1 - Charges State of Michigan

Appendix 4 - Reciprocal Compensation

Appendix 4 - Annex 1 - Prices for Reciprocal Compensation

Appendix 5 - Prices for Local Number Portability

Appendix 6 - Prices for Trunking Interconnection

Appendix 7 - Prices for E911/911 Services

Appendix 8 - Rights-of-Way, Conduits, Ducts and Pole Attachments

Appendix 9 – Treatment of ESP/ISP Traffic

Attachment 14
State of Michigan
AT&T/GTE Pricing Agreement

1. Local Service Resale

The prices charged to AT&T for Local Service shall be calculated using the avoided cost discount applicable in the State determined on the basis of the resale rate charged to subscribers for the telecommunications service requested, excluding the portion thereof attributable to any marketing, billing, collection, and other costs that will be avoided by GTE, as further specified in Appendix 1 to this Attachment 14.

The prices shall be GTE's retail rates applicable on the Effective Date, less the applicable discount. If GTE reduces its retail rates after AT&T executes this Agreement, the applicable discount shall be applied to the reduced or increased retail rates.

1.1 [Intentionally deleted.]

2. Unbundled Network Elements

The prices charged to AT&T for Network Elements shall be calculated as further specified in Appendix 2 to this Attachment 14.

3. Collocation

Prices and terms for collocation are specified in Appendix 3 to this Attachment 14.

4. Interconnection Services

GTE will make interconnection arrangements available at all tandem switching and end office switching locations. At the discretion of AT&T, local interconnection may be accomplished via one-way local trunks, or two way local trunks, or AT&T may chose to deliver both local and toll traffic over the same trunk group(s). With respect to the latter scenario, AT&T will have to provide an available Percent Local Usage (PLU) to facilitate billing if it desires application of the local interconnection rate.

Prices and terms for Interconnection Services are specified in Appendix 4 to this Attachment 14.

5. Other

Prices and terms for local number portability, trunking interconnection, E911/911 and pole attachments, conduit and rights-of-way services are specified in Appendix 5, Appendix 6, Appendix 7 and Appendix 8 to this Attachment 14, respectively.

6. Tariff Filings

At AT&T's option, AT&T shall be permitted to avail itself of any provisions of any tariff or similar filing made by GTE which provisions are more favorable than the terms, conditions and prices of this Agreement.

In the event that GTE makes a tariff filing which results in a change in an individual retail rate element or package of retail rate elements included in a Retail Offering (as defined in Appendix 1 of this Attachment 14), then such proportionate change shall be reflected in the calculation of Retail Rates (as defined in Appendix 1 of this Attachment 14).

7. Numerous provisions in this Agreement and its Attachments refer to prices or pricing principles set forth in Attachment 14. If a provision references prices in Attachment 14 and there are no corresponding prices already set forth in Attachment 14 for such item, or if any price in any portion of this Agreement, including but not limited to this Attachment 14, appears as "TBD" or is otherwise not set forth in this Agreement, such price shall be considered "To Be Determined" ("TBD"). With respect to all TBD prices, prior to AT&T ordering any such TBD item, the Parties shall meet and confer to establish a price. If the Parties are unable to reach agreement on a price for such item, an interim price shall be set for such item that is equal to the price for the nearest analogous item for which a price has been established (for example, if there is not an established price for a non-recurring charge ("NRC") for a specific Network Element, the Parties would use the NRC for the most analogous retail service for which there is an established price); provided, however, that if the Parties are unable to agree on what is the nearest analogous item for purposes of setting an interim price or if there is no such analogous item, they will submit the dispute to arbitration for purposes of establishing an interim price in accordance with the procedures set forth in Attachment 1. Any interim prices so set shall be subject to modification by any subsequent decision of the Commission. If an interim cost or price is different from the rate subsequently established by the Commission, the Parties shall

reconcile any amounts paid during the interim period such that the Parties will be made whole as if the rate(s) established by the Commission had been in effect throughout the interim period. If an interim price is different from the rate subsequently established by the Commission, any underpayment shall be paid by AT&T to GTE, or any overpayment refunded by GTE to AT&T, within forty-five (45) days after the establishment of the price by the Commission.

Appendix 1 - Local Service Resale

Beginning with the Effective Date of this Agreement, Resale Services will be priced in accordance with the standards and prices described below.

1. The wholesale rates for Local Service Resale will be calculated based upon the discounts described in Annex 1. Such discounts will be applied against the Retail Rates for each GTE Retail Offering.
 - 1.1 "Retail Rates" are the effective rates a GTE retail customer would have paid GTE under the Retail Offering selected by AT&T, taking into consideration all applicable discounts, including, but not limited to, volume, term and time of day.
 - 1.2 A "Retail Offering" is an individual service or package of services that GTE provides at retail prices to its own end-user customers and that AT&T is permitted to resell to its own end-user customers pursuant to Commission order and this Agreement.
2. The discounts and pricing methodology described in this Appendix will remain in effect for three years of this Agreement ("Initial Contract Period") and will apply to all Resale Services ordered by AT&T under this Agreement unless and until amended pursuant to pricing orders applicable to Resale Services provided by GTE to AT&T in this State. Upon expiration of the Initial Contract Period and upon written notice by a Party, the Parties agree to renegotiate the discounts and/or method for calculating wholesale prices for Resale Services, subject to the then applicable pricing standards established in accordance with Applicable Law. A Party may deliver only one request during a Contract Year. If the Parties are unable to agree upon revised discounts and/or pricing methodology within sixty (60) days of the request to renegotiate, a Party may invoke the dispute resolution procedures of Attachment 1. Until such time as the revised discounts and/or pricing methodology are agreed to, or established by the decision of the Arbitrator in the dispute resolution procedure, the discounts and/or pricing methodology described in this Appendix will continue to remain in effect.
3. The wholesale rates for Resale Services will be calculated as follows:
 - 3.1 The Month-to-Month Rate for a Retail Offering is equal to:

$$\text{Retail Rate} \times (1 - \text{applicable Baseline Discount})$$

- 3.1.1 The Baseline Discounts are specified in Annex 1 to this Attachment and shall remain in effect until renegotiated pursuant to Section 2 above.
4. [Intentionally deleted].

Appendix 1 - Annex 1 - Schedule of Wholesale Discounts

Michigan

*Consistent with the Michigan Public Service Commission orders in docket U-11281, the 16.76% discount applies when GTE does not provide OS/DA services and the 15.8% discount applies when GTE provides OS/DA services.

Basic Local Service (Residence & Business)	16.76/15.8%
Line Charge	16.76/15.8%
Usage Charge	16.76/15.8%
Features	16.76/15.8%
Listing Charges	16.76/15.8%
Non-recurring Charges	16.76/15.8%
Toll Service	16.76/15.8%
Operator Services	16.76/15.8%
Directory Assistance	16.76/15.8%
Business Trunk and Service Arrangements	16.76/15.8%
ISDN Services	16.76/15.8%
CENTRANET Services	16.76/15.8%
Private Line Services	16.76/15.8%
Inbound/Outbound Services	16.76/15.8%
Promotional Offerings (less than 90 days)	Not subject to wholesale discount
All Other Services not specifically identified above	16.76/15.8%

Appendix 1 - Annex 2 - Summary of Wholesale Charges

Local Services-Residence and Business.

Line Charges: These services should include but not be limited to the exchange line charges, by rate area within the jurisdiction. The price structure should encompass flat rates, measured rate service, one and/or two-party lines and any other subcategory that pertains to that jurisdiction. Line prices that reflect usage for such services as call-packs, extended area service, and/or community calling would be included in this category.

Usage Charges: Includes all usage not captured in the line charge, such as messages or minutes in excess of any limited calling-plan.

Features: Custom calling features and advanced custom calling features as designed to be compatible with single and multi-line residence and business customer exchange lines. Custom calling features would include month and pay per attempt charges. Associated feature discounts for quantity or other marketing bundles would also be included. (Central office features that support CENTRANET and private line services would be included with each specific service category.).

Listings: All forms of directory listings for both local and toll services. Prices for customer listing options such as bold type, dual name, business name and custom advertising for the white and yellow pages are included.

Non-recurring charges: Charges associated with the installation, addition, changing or moving of service and equipment for local service.

Toll Services: Charges for any service that have been ordered by the Commission to be open to intraLATA presubscription whether charged on a per minute of use or other basis. This includes the non-recurring and listing charges associated with installation or record affecting work for toll service or toll usage plans and for listings, advertising and associated services in the 800 service directory.

Operator Services: Charges associated with, but not limited to, obtaining operator assistance for call placement, busy-line verification and interruption, time and weather and, if priced as such, DA call completion.

Directory Assistance Services: Charges associated with the use of directory assistance operators in obtaining local telephone numbers.

Business Trunks and Service Arrangements: Charges associated with PBX trunk arrangements for single and multi-line customers. Included are line and

usage charges, features and service arrangements for direct inward (and/or outward) dialing.

ISDN Services: Charges associated with Integrated Services Digital Network Service for residence and business customers for the transmission of voice, data and packet switched signals.

CENTRANET Services: Charges associated with the provision and use of central office based private branch exchange services using equipment located on the premises owned or leased or controlled by GTE and connected by local loops to the premises of the customer or an authorized user.

Private Line Services: Charges associated with the provision and use of dedicated facilities between to two or more customer locations.

Inbound/Outbound Services: Charges associated with the provision and use of WATS 800 (inbound) and Wide Area Telephone service (outbound) and other like services.

End User Access Services: Charges associated with the provision and use of common and dedicated facilities to provide access service to end user customers.

Appendix 2 - Prices for Unbundled Network Elements

Beginning with the Effective Date of this Agreement, Network Elements **and Combinations** will be priced in accordance with the standards and prices described in this Appendix.

[Combinations]

The prices listed in this Appendix will remain in effect for the first three (3) Contract Years of this Agreement ("Initial Contract Period"), unless and until amended pursuant to the pricing orders applicable to Network Elements **and Combinations** provided by GTE to AT&T in this State. Upon expiration of the Initial Contract Period and upon written notice by a Party, the Parties agree to renegotiate any or all of the prices, subject to the then applicable pricing standards established in accordance with Applicable Law. A Party may deliver only one request per Contract Year. If the Parties are unable to agree upon revised prices within sixty (60) days of the request to renegotiate, a Party may invoke the dispute resolution procedures of Attachment 1. Until such time as the revised prices are agreed to, or established by the decision of the Arbitrator in the dispute resolution procedure, the prices described in this Appendix will continue to remain in effect except that prices shown as being determined in accordance with a GTE tariff shall change if such tariff changes.

[Combinations]

GTE shall charge for 800/888 data base dips consistent with its intrastate access tariff.

MICHIGAN

<u>Unbundled Network Elements</u>	<u>Access Areas</u>	<u>Rate/Rate Increment Per Line/Month*</u>
Unbundled Loop: 2-Wire Analog Voice Grade, per Loop	All Zones	\$23.98
4-Wire Analog Voice Grade, per Loop		\$32.62
Local Switching Port, Basic Analog Line Side Port, per port	All Zones	\$ 5.40
DS1 Digital Trunk Side Port per port	All Zones	\$86.59
Local Switching Usage Originating/terminating MOU	All Zones	.003841/min.
Directory Assistance	All Zones	TBD
Directory Connect/Call Handled	All Zones	\$0.32
Mechanized Intercept	All Zones	\$9.89
Directory Assistance Listing Initial Database Establishment/per customer	All Zones	\$819.56
Per Directory Number	All Zones	\$0.05
Creation of Magnetic Tape (shipped 3 rd Class)	All Zones	\$33.08
<u>Common/Shared Transport:</u>		
Transport facility average MOU/per Mile	All Zones	\$0.000006
Transport Termination Average MOU/per Mile	All Zones	\$0.000142
Tandem Switching Average MOU	All Zones	\$0.001263
Multiplexing DS1 to Voice, per arrangement	All Zones	\$270.24*
DS3 to DS1, per arrangement	All Zones	\$376.47*
Dedicated Transport	All Zones	See Appendix 6

<u>Unbundled Network Elements</u>	<u>Access Areas</u>	<u>Rate/Rate Increment Per Line/Month*</u>
<u>Signaling:</u>		
Signaling Links and STP 56 Kbps Links	All Zones	\$75.88
DS1 Link	All Zones	\$247.14
Signal Transfer Point (STP) Termination	All Zones	\$171.92
Call Related Database Access		
Line Information Database Cost/Query (ABS Queries)	All Zones	\$0.047846
Line Information Database Transport (ABS Queries)	All Zones	\$0.005324
Toll Free Calling Database (DB800 Queries) (per occurrence)	All Zones	\$0.011610
Local Interconnection/Local Switching/Reciprocal Compensation (End office termination)	All Zones	See Appendix 4

*Except where indicated to be per minute

MICHIGAN

<u>Unbundled Network Elements</u>	<u>Access Areas</u>	<u>Rate/Rate Increment Per Line/Month</u>
Unbundled Element Platform	A	TBD
	B	TBD
	C	TBD
Unbundled Element Platform Without Operator Systems	A	TBD
	B	TBD
	C	TBD
Loop/Network Combination	A	TBD
	B	TBD
	C	TBD
Switching Combination #1	All Zones	TBD
[Combinations]		

Non-Recurring (Service Ordering and Installation) Charges:

(A) Service Order Charge, Loop or Port

(1) Initial Service Order Charge, per order	All Zones	\$ 5.00
(2) Transfer of Service Charge, per order	All Zones	\$ 5.00
(3) Subsequent Service Order Charge, per order	All Zones	\$ 5.00
(4) Customer Service Record Research, per order	All Zones	\$ 5.00

(B) Installation

(1) Unbundled Loop, per Loop	All Zones	\$4.63
(2) Unbundled Port, per Port	All Zones	\$4.63
(3) Loop Facility Charge, per trip	All Zones	\$25.50

Appendix 3 - Prices for Collocation

1. Charges.

- 1.1 Collocation will be priced in accordance with the standards and charges described in this Appendix 3.
- 1.2 The charges for Collocation are as set forth in Annex 1 to this Appendix 3.
- 1.3 The charges set forth in this Appendix 3 will remain in effect for the first three (3) Contract Years of this Agreement ("Initial Contract Period") unless amended pursuant to pricing orders applicable to collocation provided by GTE to AT&T in this State. Upon expiration of the Initial Contract Period, upon written notice by a Party, the Parties agree to renegotiate any or all of the prices, subject to the then applicable pricing standards established in accordance with Applicable Law. A Party may deliver only one request to renegotiate during a Contract Year. If the Parties are unable to agree upon revised prices within sixty (60) days of the request to renegotiate, a Party may invoke the dispute resolution procedures of Attachment 1. Until such time as the revised prices are agreed to, or established by the decision of the Arbitrator in the dispute resolution procedure, the prices described in this Appendix will continue to remain in effect.
- 1.4 Extraordinary costs may only be billed to AT&T if such costs have been authorized by AT&T. GTE must advise AT&T if extraordinary costs will be incurred within ten (10) business days of AT&T's request for space. Otherwise, AT&T will not be responsible for such costs. Extraordinary costs do not include costs associated with maintenance and upkeep of the building.

2. Payment.

AT&T will pay the charges for Collocation upon receipt of an itemized invoice from GTE. GTE will provide AT&T with an itemized invoice of all charges on a per LSO basis.

Appendix 3 - Annex 1 - Charges - State of Michigan

COLLOCATION RATE CATEGORIES		TOTAL PRICE Non-recurring	TOTAL PRICE Recurring
Expanded Interconnection Service Cross Connect (EISCC)			
1.	Per Voice Grade DS0 Connection		\$ 12.73
2.	Per DS1 Connection		\$ 31.97
3.	Per DS3 Connection		\$ 334.18
4.	DC Power Installation (per 40 amps) (monthly charge per 40 amps)	\$ 1,447.11	\$ 429.96
5.	Partition Space (per square foot)		\$ 2.32
6.	Engineering Fee for Physical Arrangements, per request	\$ 1,697.66	
7.	Building Modification, per central office		
	Simple	\$ 9,782.04	
	Moderate	\$13,358.83	
	Complex	\$17,046.85	
8.	Cable Space Charge (per 12 fiber)		\$ 23.23
9.	Cable Pull Charge (per 12 fiber)	\$ 697.80	
10.	Cage Enclosure, per cage	\$ 2,764.85	

Appendix 4 - Reciprocal Compensation

1. Scope.

This Appendix 4 prescribes the methods and means for reciprocal compensation of interconnect traffic between GTE's and AT&T's networks as well as transiting traffic between AT&T and third party LECs or ILECs.

2. Interconnecting Local Traffic.

2.1 Compensation for exchange of Local Traffic will be paid on a Bill and Keep basis.

3. Transiting Traffic.

3.1. AT&T shall pay to GTE a Transiting Service Charge for the use of its Tandem Switching as described in Annex 1 to this Appendix 4.

4. Information Services Traffic.

The Information Services Billing and Collection Charge is set forth in Annex 1 to this Appendix 4.

5. BLV/BLVI Traffic.

Each party shall charge the other for BLV/BLVI Services on a bill and keep basis.

Appendix 4 - Annex 1 - Prices for Reciprocal Compensation

The prices listed in this Annex will remain in effect for the first three (3) years of this Agreement ("Initial Contract Period"), unless amended pursuant to pricing orders applicable to the services provided to each other by GTE and AT&T in the State listed in this Appendix 4. Upon expiration of the Initial Contract Period, upon written notice by a Party, the Parties agree to renegotiate any or all of the prices, subject to the then applicable pricing standards established in accordance with Applicable Law. A Party may deliver only one request to renegotiate during a Contract Year. If the Parties are unable to agree upon revised prices within sixty (60) days of the request to renegotiate, a Party may invoke the dispute resolution procedures of Attachment 1. Until such time as the revised prices are agreed to, or established by the decision of the Arbitrator in the dispute resolution procedure, the prices described in this Annex will continue to remain in effect.

End-Office Interconnection, Local Switching Rate:

\$ 0.003841 per minute of use

Tandem Interconnection Rate:

Local Switching, per MOU	\$0.003841
Transport Termination, per Term per MOU	\$0.000142
Transport Facility per mile per MOU	\$0.000006
Tandem Switching, Per MOU	\$0.001263

Tandem Transiting:

Transport Termination, per Term per MOU	\$0.000142
Transport Facility, per Mile per MOU	\$0.000006
Tandem Switching, per MOU	\$0.001263

Information Services Billing and Collection Charge:

[TBD]

Appendix 5 - Prices for Local Number Portability

There will be no charge for number portability provided by one Party for the other.

Appendix 6 - Prices for Trunking Interconnection

The prices listed in this Appendix 6 will remain in effect for the first three (3) years of this Agreement ("Initial Contract Period"), unless amended pursuant to pricing orders applicable to the services provided in the State listed in this Appendix. Upon expiration of the Initial Contract Period, upon written notice by a Party, the Parties agree to renegotiate any or all of the prices, subject to the then applicable pricing standards established in accordance with Applicable Law. A Party may deliver only one request to renegotiate during a Contract Year. If the Parties are unable to agree upon revised prices within sixty (60) days of the request to renegotiate, a Party may invoke the dispute resolution procedures of Attachment 1. Until such time as the revised prices are agreed to, or established by the decision of the Arbitrator in the dispute resolution procedure, the prices described in this Appendix will continue to remain in effect.

Dedicated Transport Rates:

AT&T Furnished Dedicated Transport

TBD in accordance with the methodology set forth in Section 7 of this Attachment 14.

GTE Dedicated Transport

Interoffice Dedicated Transport

IDT DSO Transport Facility, per Mile	\$0.03534
IDT DSO Transport Termination, per Term	\$12.81
IDT DS1 Transport Facility, per mile	\$0.85994
IDT DS1 Transport Termination, per Term	\$31.97
IDT DS3 Transport Facility, per Mile	\$21.59
IDT DS3 Transport Termination, per Term	\$334.18

CLEC Dedicated Transport

CDT 2-Wire, per Line	\$24.15
CDT 4-Wire, per Line	\$32.86
CDT DS1, per Line	\$211.84
CDT DS3, per Line	\$2326.98

Appendix 7 - Prices for E911/911 Services

The prices listed in this Appendix 7 will remain in effect for the first three (3) years of this Agreement ("Initial Contract Period"), unless amended pursuant to pricing orders applicable to the services provided in the State listed in this Appendix. Upon expiration of the Initial Contract Period, upon written notice by a Party, the Parties agree to renegotiate any or all of the prices, subject to the then applicable pricing standards established in accordance with Applicable Law. A Party may deliver only one request to renegotiate during a Contract Year. If the Parties are unable to agree upon revised prices within sixty (60) days of the request to renegotiate, a Party may invoke the dispute resolution procedures in Attachment 1. Until such time as the revised prices are agreed to, or established by the decision of the Arbitrator in the dispute resolution procedure, the prices described in this Appendix will continue to remain in effect.

[TBD]

Appendix 8 - Rights-of-Way, Conduits, Ducts, and Pole Attachments

Prices. The prices charged to AT&T for Rights-of-Way, Conduit and Pole Attachments will be set at GTE's TSLRIC, subject to requirements of this Appendix and Section 361 of the MTA. AT&T will pay only for work needed to condition capacity for AT&T's use. GTE shall provide an auditable process that insures that AT&T is properly charged for this work.

If AT&T requests that a route be made available, AT&T shall provide GTE with such technical information and specifications as are necessary for GTE to determine whether a route sufficient to meet AT&T's request is available. If a route is available, GTE shall advise AT&T as to the availability of the route and shall provide information sufficient for AT&T to determine whether the proposed route would meet AT&T's needs. AT&T shall verify and confirm that based on the information GTE has provided the proposed route would meet AT&T's needs. If AT&T verifies and confirms that the proposed route would meet AT&T's needs and subsequently AT&T notifies GTE that the route does not meet AT&T's needs for reasons including, but not limited to, errors in the information provided to GTE for purposes of identifying the appropriate route or AT&T changing its required specifications, or otherwise through fault of AT&T, AT&T shall bear all costs of preparing the route up until such point and for the costs of modifying the route to meet AT&T's requests. AT&T shall not, however, be responsible for such costs as are associated with preparing, modifying, or repairing such portion of the route as are necessary to meet AT&T's original requests to the extent GTE is at fault for the deviation of the route from the original request. To the extent both Parties are responsible for the deviation or neither Party is responsible, the Parties shall bear the costs of preparing, modifying, or repairing such portion equally.

GTE and AT&T shall agree on a verifiable mechanism or process to ensure that AT&T is properly charged for such work and that, where necessary, costs are allocated and prorated in a nondiscriminatory and competitively neutral manner in accordance with effective and applicable methodology approved by the FCC or the Commission. When AT&T places a request with GTE for work to be performed for AT&T in connection with Rights of Way, Conduit and Pole Attachments, GTE shall submit to AT&T a detailed estimate for such work as soon as practicable after the receipt of the request. GTE shall not commence work on the request until it receives prior authorization from AT&T. All invoices submitted by GTE shall include a detailed itemization of all work covered thereunder.

Appendix 9 - Treatment of ESP/ISP Traffic

The Parties have not agreed as to how ESP/ISP Traffic should be exchanged between the Parties and whether and to what extent compensation is due either Party for exchange of such traffic. GTE's position is that the FCC cannot divest itself of rate setting jurisdiction over such traffic, that such traffic is interstate and subject to Part 69 principles, and that a specific interstate rate element should be established for such traffic. AT&T's position is that ESP/ISP traffic should be treated as local for the purposes of inter-carrier compensation and should be compensated on the same basis as voice traffic between end users. The FCC has issued a NPRM on prospective treatment of ESP/ISP traffic. Nevertheless, without waiving any of its rights to assert and pursue its position on issues related to ESP/ISP Traffic, each Party agrees that until the FCC enters a final, binding, and nonappealable order ("Final FCC Order"), the Parties shall exchange and each Party may track ESP/ISP Traffic but no compensation shall be owed for ESP/ISP Traffic exchanged between the Parties and neither Party shall bill the other for such traffic. At such time as a "Final FCC Order" becomes applicable, the Parties shall meet to discuss implementation of the Order and shall make adjustments to reflect the impact of the Order. This agreement to leave issues related to ESP/ISP Traffic unresolved until after the Final FCC Order becomes applicable and in the interim to not compensate for ESP/ISP Traffic, shall in no manner whatsoever establish any precedent, waiver, course of dealing or in any way evidence either Parties' position or intent with regard to exchange and/or compensation of ESP/ISP Traffic, each party reserving all its rights with respect to these issues.

ATTACHMENT 15

RECIPROCAL COMPENSATION FOR CALL TERMINATION AGREEMENT

1. This Attachment describes the reciprocal compensation arrangements between AT&T and GTE for Local Traffic, Toll, and Switched Access Services. The Parties shall compensate each other for transport and termination of such traffic at the rates provided in Attachment 14 (Pricing) and/or the appropriate Parties' Switched Access Tariff. The Parties recognize that the charges set forth in this Attachment may be revised, replaced, supplemented, superseded or eliminated pursuant to Applicable Law. To the extent any such changes result in new or additional charges, such new or additional charges shall apply. Additionally, to the extent charges not set forth in this Attachment are or become applicable to the services for which charges are being applied pursuant to this Attachment or other sections of this Agreement, such charges shall also apply. In no event shall the listing of charges in this Attachment or lack thereof require the payment of charges that have been eliminated or limit the charges due to either Party pursuant to Applicable Law.
2. Compensation for Call Termination
 - A. Reciprocal compensation does not apply in a resale environment.
 - B. The following compensation terms, as specified in Unbundled Network Element pricing listed in Attachment 14, shall apply in all cases where AT&T purchases GTE's unbundled Local Switching:
 1. For Local intra-switch calls between lines connected to GTE's switch where AT&T has purchased GTE's unbundled Local Switching, the Parties agree to impose no call termination charges on each other. GTE's Local Switching charge will apply as described below where the call is :
 - (a) Originated by AT&T's customer and completed to a GTE customer:
 - (1) (For use of the local switch:) Local Switching charge at the originating office will apply to AT&T.
 - (b) Originated by AT&T's customer and completed to the customer of a third party LEC (not affiliated with AT&T) using GTE's unbundled Local Switching:
 - (1) (For use of the local switch:) Local Switching charge at the originating office will apply to AT&T.

- (c) Originated by AT&T's customer and completed to another of AT&T's customers using GTE's unbundled Local Switching.
 - (1) (For use of the local switch:) Local Switching charge at the originating office will apply to AT&T.
- (d) Originated by a GTE customer and terminated to AT&T's customer using GTE's unbundled Local Switching.
 - (1) No Local Switching charge will apply to AT&T.
- (e) Originated by the customer of a third party LEC (not affiliated with AT&T) using GTE's Unbundled Local Switching and terminated to AT&T's customers using GTE's unbundled Local Switching.
 - (1) No Local Switching charge will apply to AT&T.

2. For Local inter-switch calls where AT&T has purchased GTE's unbundled Local Switching, the Parties agree to call termination charges as applicable and as described in Attachment 14, Appendix 4, Section 2.

GTE's charges will apply to AT&T as described below where the call is:

- (a) Originated from AT&T's end-user customer using GTE's unbundled Local Switching and completed to a GTE customer.
 - (1) (For use of the local switch:) Local Switching charge at the originating office will apply to AT&T.
 - (2) A mileage-based transport charge will apply when AT&T uses GTE's transport.
 - (3) (For call termination) Charges for local interconnection/call termination, when applicable, as set forth in Attachment 14, Appendix 4.
- (b) Originated from AT&T's customer using GTE's unbundled Local Switching and completed to a third party LEC (not affiliated with AT&T) customer using GTE's unbundled Local Switching.
 - (1) (For use of the local switch:) Local Switching charge at the originating office will apply to AT&T.

- (2) A mileage-based transport charge will apply when AT&T uses GTE's transport.
- (c) Originated from AT&T's customer using GTE's unbundled Local Switching and completed to the interconnected network of a third party LEC (not affiliated with AT&T).
- (1) (For use of the local switch:) Local Switching charge at the originating office will apply to AT&T.
 - (2) A mileage-based transport charge will apply when AT&T uses GTE's transport, and mileage shall be measured between the originating office and the POI of the third party's network.
- (d) Originated from AT&T's customer using GTE's unbundled Local Switching and completed to AT&T's customer using GTE's unbundled Local Switching.
- (1) (For use of the local switch:) Local Switching charge at the originating office will apply to AT&T.
 - (2) A mileage-based transport charge will apply when AT&T uses GTE's transport.
 - (3) (For use of the local switch:) Local Switching charge at the terminating office.
- (e) Originated by a GTE customer and terminated to AT&T's customer using GTE's unbundled Local Switching.
- (1) (For use of the local switch:) Local Switching Charge at the terminating office will apply to AT&T.
 - (2) (For call termination) AT&T shall charge GTE for local interconnection/call termination, when applicable, as set forth in Attachment 14, Appendix 4.
- (f) Originated by a customer of a third-party LEC (not affiliated with AT&T) using GTE's unbundled Local Switching and terminated to AT&T's customer using GTE's unbundled Local Switching.
- (1) (For use of the local switch:) Local Switching charge at the terminating office will apply to AT&T.

- (g) Originated by a customer on the interconnected network of a third-party LEC (not affiliated with AT&T) and terminated to AT&T's customer using GTE's unbundled Local Switching.
 - (1) (For use of the local switch:) Local Switching charge at the terminating office will apply to AT&T.

- 3. For intraLATA toll calls where AT&T has purchased GTE's unbundled Local Switching, charges per Unbundled Network Element pricing listed in Attachment 14 shall apply as follows:
 - (a) Originated by AT&T's customer and completed to a GTE customer.
 - (1) (For use of the local switch:) Local Switching charge plus RIC (Residual Interconnection Charge, also called the Transport Interconnection Charge or the Interconnection Charge), if applicable, and CCLC (Common Carrier Line Charge), if applicable, at the originating office will apply to AT&T.
 - (2) Shared transport charge between the two offices will apply when AT&T uses GTE's transport.
 - (3) (For call termination) End Office Switching charge at the terminating office (Switched Access Rate) will apply to AT&T.
 - (4) CCLC, if applicable, at the terminating office.
 - (5) RIC, if applicable, at the terminating office.
 - (b) Originated by AT&T's customer and completed to the customer of a third-party LEC (not affiliated with AT&T) using GTE's unbundled Local Switching in a distant end office.
 - (1) (For use of the local switch:) Local Switching charge plus RIC, if applicable, and CCLC, if applicable, at the originating office will apply to AT&T.
 - (2) Shared transport charge between the two offices will apply when AT&T uses GTE's transport.
 - (c) Originated by AT&T's customer and completed to the network of third-party LEC (not affiliated with AT&T) interconnected with GTE's network.

- (1) (For use of the local switch:) Local Switching charge, plus RIC, if applicable, and CCLC, if applicable, at the originating office will apply to AT&T.
 - (2) Common transport charge will apply when AT&T uses GTE's transport, and mileage shall be measured between the originating office and the POI of the third party's network.
 - (3) Tandem Switching, where applicable.
- (d) Originated by AT&T's customer and completed to another of AT&T's customers being served through GTE's unbundled Local Switching in a distant office.
- (1) (For use of the local switch:) Local Switching charge plus RIC, if applicable, and CCLC, if applicable, at the originating office will apply to AT&T.
 - (2) Shared transport charge between the two offices will apply when AT&T uses GTE's transport.
 - (3) (For use of the local switch:) Local Switching charge plus RIC, if applicable, and CCLC, if applicable, at the terminating office will apply to AT&T.
- (e) Originated by a GTE customer and terminated to AT&T's customer using GTE's unbundled Local Switching.
- (1) (For use of the local switch:) Local Switching charge plus RIC, if applicable, and CCLC, if applicable, at the terminating office.
 - (2) (For call termination:) AT&T will charge GTE Local Switching at the terminating office (Switched Access Rate).
 - (3) (For call termination:) AT&T will charge GTE RIC, if applicable, at the terminating office.
- (f) Originated by the customer of a third-party LEC (not affiliated with AT&T) using GTE's unbundled Local Switching in a distant end office and terminated to AT&T's customer using GTE's unbundled Local Switching.

- (1) (For use of the local switch:) Local Switching charge plus RIC, if applicable, and CCLC, if applicable, at the terminating office will apply to AT&T.
 - (g) Originated by a customer on the network of a third-party LEC (not affiliated with AT&T) interconnected with GTE's network and terminated to AT&T's customer using GTE's unbundled Local Switching.
 - (1) (For use of the local switch:) Local Switching charge plus RIC, if applicable, and CCLC, if applicable, at the terminating office will apply to AT&T.
4. For intrastate Switched Access calls where AT&T is using GTE's unbundled Local Switching for calls originated from or terminated to an IXC for completion:
- (a) For calls originated from AT&T's customer to AT&T's own IXC switch (or that of an affiliate) for completion.
 - (1) (For use of the local switch:) Local Switching charge at the originating office.
 - (2) Originating RIC and CCLC if such charges are applicable.
 - (3) GTE will charge AT&T's IXC affiliate the following Switched Access elements on a meet-point basis:
 - a. Local Transport
 - b. Tandem Switching
 - (b) For calls originated from AT&T's customer to an IXC's switch not affiliated with AT&T.
 - (1) (For use of the local switch:) Local Switching charge at the originating office.
 - (2) Originating RIC and CCLC if such charges are applicable.
 - (3) GTE shall charge the non-affiliated IXC for the following originating Switched Access on a meet-point basis:
 - a. Local Transport

- b. Tandem Switching
 - (c) For calls terminating to AT&T's end-user customer from AT&T's own IXC switch (or that of an affiliate) for completion.
 - (1) (For use of the local switch:) Local Switching charge at the terminating office.
 - (2) Terminating RIC and CCLC if such charges are applicable.
 - (3) GTE will charge AT&T's IXC (affiliate) the following Switched Access elements on a meet-point basis:
 - a. Local Transport
 - b. Tandem Switching
 - (d) For calls terminating to AT&T's customer from an IXC switch not affiliated with AT&T.
 - (1) (For use of the local switch:) Local Switching charge at the terminating office.
 - (2) Terminating RIC and CCLC if such charges are applicable.
 - (3) GTE shall charge the IXC for the following terminating Switched Access on a meet-point basis:
 - a. Local Transport
 - b. Tandem Switching
5. For interstate Switched Access calls where AT&T is using GTE's unbundled Local Switching for calls originated from or terminated to an IXC for completion:
- (a) For calls originated from AT&T's customer to AT&T's own IXC switch (or that of an affiliate) for completion.
 - (1) (For use of the local switch:) Local Switching charge at the originating office.
 - (2) Originating RIC and CCLC if such charges are applicable.

- (3) GTE shall charge AT&T's IXC affiliate for the following originating Switched Access on a meet-point basis:
 - a. Local Transport
 - b. Tandem Switching
- (b) For calls originated from AT&T's customer to an IXC's switch not affiliated with AT&T.
 - (1) (For use of the local switch:) Local Switching charge at the originating office.
 - (2) Originating RIC and CCLC if such charges are applicable.
 - (3) GTE shall charge the IXC for the following originating Switched Access on a meet-point basis:
 - a. Local Transport
 - b. Tandem Switching
- (c) For calls terminating to AT&T's customer from AT&T's own IXC switch (or that of an affiliate) for completion.
 - (1) (For use of the local switch:) Local Switching charge at the terminating office.
 - (2) Terminating RIC and CCLC if such charges are applicable.
 - (3) GTE will charge AT&T's IXC (affiliate) the following Switched Access elements on a meet-point basis:
 - a. Local Transport
 - b. Tandem Switching
- (d) For calls terminating to AT&T's customer from an IXC switch not affiliated with AT&T.
 - (1) (For use of the local switch:) Local Switching charge at the terminating office.
 - (2) Terminating RIC and CCLC if such charges are applicable.

- (3) GTE shall charge the non-affiliated IXC for the following terminating Switched Access on a meet-point basis:
 - a. Local Transport
 - b. Tandem Switching
- C. The following terms apply where AT&T and GTE interconnect using their own networks.
 1. For Local Traffic and intraLATA Toll traffic originated by AT&T (or CLECs subtending its network) to GTE, AT&T agrees to pay GTE the following:
 - (a) Local calls: Unless otherwise provided in Attachment 14, Bill and Keep shall apply to Local Traffic.
 - (b) Toll calls: The following GTE Intrastate Switched Access rate elements, if such charges are applicable to intraLATA toll calls.
 - (1) For common switched transport where GTE's tandem is used:
 - (a) Fixed - per minute of use.
 - (b) Variable - per mile per minute of use. Mileage shall be calculated based on the airline miles between the Vertical and Horizontal ("V&H") coordinates of the POI, and the GTE end office or Competitive Local Carrier routing point.
 - (c) Tandem Switching.
 - (2) End Office switching.
 - (3) Information Surcharge
 - (4) RIC
 - (5) CCLC
 2. For Local Traffic and intraLATA Toll traffic originated from GTE to AT&T, GTE agrees to pay AT&T the following:

- (a) Local calls: Unless otherwise provided in Attachment 14, Bill and Keep shall apply to Local Traffic.
- (b) Toll calls: The following AT&T Intrastate Switched Access rate elements, if such charges are applicable to intraLATA toll calls.
 - (1) For common switched transport where AT&T's tandem is used:
 - (a) Fixed - per minute of use.
 - (b) Variable - per mile per minute of use. Mileage shall be calculated based on the airline miles between the Vertical and Horizontal ("V&H") coordinates of the POI, and the AT&T end office or Competitive Local Carrier/AT&T routing point.
 - (c) Tandem Switching.
 - (2) End Office switching.
 - (3) Information Surcharge
 - (4) RIC
 - (5) CCLC

AMENDMENT NO. 1

to the

INTERCONNECTION, RESALE AND UNBUNDLING AGREEMENT

between

**VERIZON NORTH INC., f/k/a GTE NORTH INCORPORATED
CONTEL OF THE SOUTH, INC., d/b/a VERIZON NORTH SYSTEMS**

and

AT&T COMMUNICATIONS OF MICHIGAN, INC.

THIS AMENDMENT No. 1 (this "Amendment") is made this 30th day of March 2003 (the "Effective Date"), by and between Verizon North Inc., f/k/a GTE North Incorporated, Contel of the South, Inc., d/b/a Verizon North Systems, a Wisconsin corporation (collectively "Verizon"), on the one hand, each providing service within its respective service territory in Michigan, and both with a principal place of business at 100 Executive Drive, Marion, OH 43302, and AT&T Communications of Michigan, Inc., a Michigan corporation ("AT&T"), on the other hand, with its principal place of business at One AT&T Way, Bedminster, NJ 07921. (Verizon and AT&T may be hereinafter referred to, each individually, as a "Party" and, collectively, as the "Parties"). This Amendment covers services in the Verizon service territory in the State of Michigan (the "State").

WITNESSETH:

WHEREAS, Verizon and AT&T are Parties to an interconnection agreement under Sections 251 and 252 of the Telecommunications Act of 1996 filed with the Commission dated August 2, 1999 (the "Agreement").

WHEREAS, subsequent to the approval of the Agreement, AT&T notified Verizon that it desired to amend the Agreement as set forth herein; and

WHEREAS, the Agreement contains disputed language marked as the "Combinations Issue" subject to amendment by the Parties; and

WHEREAS, in accordance with Section 1.1 of the Agreement, the Parties agree to amend the Agreement whereby Verizon is prepared to provide UNE-P Combinations (as defined in Section 1(a) below) to AT&T to the extent required by Applicable Law (which term, for the avoidance of any doubt, includes, without limitation, the impending rules, once they become effective and, as they are amended and in effect from time to time, of the FCC in CC Docket Nos. 01-338, 96-98 and 98-147);

NOW, THEREFORE, in consideration of the mutual promises, provisions and covenants herein contained, the sufficiency of which is hereby acknowledged, the Parties agree as follows:

1. Amendment to the Agreement. Effective as of the date first set forth above, the Agreement is amended hereby as follows:

(a) Platform Combinations. To the extent required by Applicable Law, as well as subject to the conditions set forth in Section 1(b) of this Amendment, Verizon shall provide a platform combination (a "UNE-P Combination") consisting of an Unbundled Local Loop (including the NID), a Local Switching Element, transport unbundled network elements and other network elements, if any, Verizon is required under Applicable Law to provide as part of a UNE-P Combination. To the extent Verizon is required by Applicable Law to provide a UNE-P Combination to AT&T, Verizon shall provide such UNE-P Combination in accordance with, and subject to, requirements established by Verizon that are consistent with Applicable Law (such requirements, the "Combo Requirements"). Verizon shall make the Combo Requirements publicly available in an electronic form. Without limiting Verizon's rights pursuant to Applicable Law or any other section of the Agreement to terminate its provision of a UNE-P Combination (or an applicable network element) and, notwithstanding any other provision of this Amendment or otherwise, if Verizon provides a UNE-P Combination to AT&T, and the Commission, the FCC, a court or other governmental body of appropriate jurisdiction determines or has determined that Verizon is not required by Applicable Law to provide such UNE-P Combination (or an applicable network element), Verizon may terminate its provision of such UNE-P Combination (or applicable network element) to AT&T on prior written notice thereof provided after the relevant determination becomes effective (provided, however, that the number of days' notice shall be the period, if any, prescribed by the Commission, the FCC, a court or other governmental body of appropriate jurisdiction in its determination and, in the absence of a prescribed period, shall be thirty (30) days).

(b) Limitations. Notwithstanding anything set forth in the Agreement:

(1) Nothing contained in the Agreement or this Amendment shall be deemed to constitute an agreement by Verizon that any item identified in the Agreement or this Amendment as a network element is (i) a network element under Applicable Law, or (ii) a network element Verizon is required by Applicable Law to provide to AT&T on an unbundled basis. Nothing contained in the Agreement or this Amendment shall limit Verizon's or AT&T's right to appeal, seek reconsideration of or otherwise seek to have stayed, modified, reversed or invalidated any order, rule, regulation, decision, ordinance or statute issued by the Michigan Public Service Commission, the FCC, any court or any other governmental authority related to, concerning or that may affect Verizon's obligations or AT&T's rights under the Agreement, this Amendment or Applicable Law.

(2) Notwithstanding anything set forth in the Agreement, Verizon shall be required to provide a UNE-P Combination (or a network element on an unbundled basis) only where necessary facilities are available.

(c) Notwithstanding anything else set forth in the Agreement or this Amendment and subject to the conditions set forth in Section 1(b) of this Amendment:

(1) Verizon shall provide access to Unbundled Local Loops, Local Switching Elements and UNE-P Combinations subject to charges based on rates and/or rate structures that are consistent with Applicable Law (rates and/or rate structures for access to Unbundled Local Loops, Local Switching Elements and UNE-P Combinations, collectively, the

“Rates” and, individually, a “Rate”). These Rates are as Verizon communicated to AT&T in a December 31, 2001 industry letter titled "UNE Rates for Existing Interconnection Agreements," as amended from time to time, and shall apply until such time as they are replaced by new rates as may be approved or allowed to go into effect by the Michigan Public Service Commission or the FCC from time to time, subject however, to any stay or other order issued by any court of competent jurisdiction for the State of Michigan.

(d) The Parties agree that the terms and conditions in this Amendment resolve all disputed language in the Agreement marked as the Combinations Issue as it applies, and only to the extent it applies, to UNE-P Combinations. All disputed language in the Agreement marked as the Combinations Issue as it applies to other forms of Combinations remains unresolved and, pursuant to Section 1.1 of the Agreement, shall not be applied or used by the Parties until the Parties further amend the Agreement consistent with Applicable Law.

2. Conflict between this Amendment and the Agreement. This Amendment shall be deemed to revise the terms and provisions of the Agreement to the extent necessary to give effect to the terms and provisions of this Amendment. In the event of a conflict between the terms and provisions of this Amendment and the terms and provisions of the Agreement, this Amendment shall govern, *provided, however*, that the fact that a term or provision appears in this Amendment but not in the Agreement, or in the Agreement but not in this Amendment, shall not be interpreted as, or deemed grounds for finding, a conflict for purposes of this Section 2.

3. Counterparts. This Amendment may be executed in one or more counterparts, each of which when so executed and delivered shall be an original and all of which together shall constitute one and the same instrument.

4. Captions. The Parties acknowledge that the captions in this Amendment have been inserted solely for convenience of reference and in no way define or limit the scope or substance of any term or provision of this Amendment.

5. Scope of this Amendment. This Amendment shall amend, modify and revise the Agreement only to the extent set forth expressly in Section 1 of this Amendment, and, except to the extent set forth in Section 1 of this Amendment, the terms and provisions of the Agreement shall remain in full force and effect after Effective Date.

SIGNATURE PAGE

IN WITNESS WHEREOF, the Parties hereto have caused this Agreement to be executed as of the Effective Date.

**AT&T COMMUNICATIONS OF
MICHIGAN, INC.**

**VERIZON NORTH INC.
CONTEL OF THE SOUTH, INC., d/b/a
VERIZON NORTH SYSTEMS**

By: _____

By: _____

Printed: _____

Printed: _____

Title: _____

Title: _____

AMENDMENT NO. 2

to the

INTERCONNECTION, RESALE AND UNBUNDLING AGREEMENT

between

VERIZON NORTH INC., f/k/a GTE NORTH INCORPORATED,

CONTEL OF THE SOUTH, INC., d/b/a VERIZON NORTH SYSTEMS

and

AT&T COMMUNICATIONS OF MICHIGAN, INC.

THIS AMENDMENT No. 2 (this "Amendment") is made this 30th day of April 2003 (the "Effective Date"), by and between Verizon North Inc., f/k/a GTE North Incorporated, and Contel of the South, Inc., d/b/a Verizon North Systems, each a Wisconsin corporation (collectively "Verizon"), on the one hand, each providing service within its respective service territory in Michigan, and both with a principal place of business at 100 Executive Drive, Marion, OH 43302, and AT&T Communications of Michigan, Inc., a Michigan corporation ("AT&T"), on the other hand, with its principal place of business at One AT&T Way, Bedminster, NJ 07921. (Verizon and AT&T may be hereinafter referred to, each individually, as a "Party" and, collectively, as the "Parties"). This Amendment covers services in the Verizon service territory in the State of Michigan (the "State").

WITNESSETH:

WHEREAS, Verizon and AT&T are Parties to an interconnection agreement under Sections 251 and 252 of the Telecommunications Act of 1996 filed with the Commission dated August 2, 1999 (the "Agreement").

WHEREAS, AT&T has requested that the Parties amend the Agreement to provide for "Line Splitting" (as defined herein); and

WHEREAS, Verizon is prepared to provide for Line Splitting on the terms and conditions set forth herein but, notwithstanding any other provision of this Amendment or otherwise, only to the extent required by Applicable Law (which term, for the avoidance of any doubt, includes, without limitation, the impending rules, once they become effective and, as they are amended and in effect from time to time, of the FCC in CC Docket Nos. 01-338, 96-98 and 98-147).

NOW, THEREFORE, in consideration of the mutual promises, provisions and covenants herein contained, the sufficiency of which is hereby acknowledged, the Parties agree as follows:

1. Amendment to the Agreement. Effective as of the date first set forth above, the Agreement is amended hereby as follows:

(a) The following paragraph shall be added to Attachment 2 (Service Description: Unbundled Network Elements) of the Agreement:

"3.6 Line Splitting

AT&T may provide integrated voice and data services over the same Loop by engaging in "Line Splitting" as set forth in paragraph 18 of the FCC's Line Sharing Reconsideration Order (CC Docket Nos. 98-147, 96-98), released January 19, 2001. Any Line Splitting between AT&T and another CLEC shall be accomplished by prior negotiated arrangement between those CLECs. To achieve a Line Splitting capability, AT&T may utilize supporting Verizon OSS to order and combine in a Line Splitting configuration an unbundled xDSL Compatible Loop terminated to a collocated splitter and Digital Subscriber Line Access Multiplexer ("DSLAM") equipment provided by its data partner (or itself), unbundled switching combined with shared transport, collocator-to-collocator connections, and available cross-connects, under the terms and conditions set forth in their respective interconnection agreement(s). AT&T shall provide Verizon with the information required by FCC Rules regarding the type of xDSL technology that it deploys on each loop facility employed in Line Splitting. Unless the Parties agree otherwise, this information will be conveyed by the Network Channel/Network Channel Interface Code (NC/NCI) or equivalent. AT&T or its data partner shall provide any splitters used in a Line Splitting configuration. To the extent AT&T seeks to migrate an existing UNE-P Combination to a Line Splitting configuration using the same Network Elements utilized in the pre-existing UNE-P Combination, it may do so consistent with such implementation schedules, terms, conditions and guidelines as are agreed upon for such migrations in the ongoing DSL Collaborative in the State of New York, NY PSC Case 00-C-0127, allowing for local jurisdictional and OSS differences. Notwithstanding any provision of this Agreement or otherwise, the foregoing Verizon obligations (and CLEC rights) in connection with Line Splitting shall apply only to the extent Verizon is required to undertake such obligations and the CLECs have such rights, in each case under Applicable Law. Without limiting Verizon's rights pursuant to Applicable Law or any other section of the Agreement to terminate its provision of Line Splitting (or an applicable network element) and, notwithstanding any other provision of this Agreement or otherwise, if Verizon provides Line Splitting to AT&T, and the Commission, the FCC, a court or other governmental body of appropriate jurisdiction determines or has determined that Verizon is not required by Applicable Law to provide such Line Splitting arrangements (or an applicable network element), Verizon may terminate its provision of such Line Splitting arrangements (or applicable network element) to AT&T on prior written notice thereof provided after the relevant determination becomes effective (provided, however, that the number of days' notice shall be the period, if any, prescribed by the Commission, the FCC, a court or other governmental body of appropriate jurisdiction in its determination and, in the absence of a prescribed period, shall be thirty (30) days)."

(b) The following definition shall be added to Attachment 11 (Definitions) of the Agreement:

"xDSL" is as defined and offered in this Agreement. The small "x" before the letters DSL signifies reference to DSL as a generic transmission technology, as opposed to a specific DSL "flavor."

(c) Limitations. Notwithstanding anything set forth in the Agreement:

(i) Nothing contained in the Agreement or this Amendment shall be deemed to constitute an agreement by Verizon that any item identified in the Agreement or this Amendment as a network element is (A) a network element under Applicable Law, or (B) a network element Verizon is required by Applicable Law to provide to AT&T on an unbundled basis. Nothing contained in the Agreement or this Amendment shall limit Verizon's or AT&T's right to appeal, seek reconsideration of or otherwise seek to have stayed, modified, reversed or invalidated any order, rule, regulation, decision, ordinance or statute issued by the Michigan Public Service Commission, the FCC, any court or any other governmental authority related to, concerning or that may affect Verizon's obligations or AT&T's rights under the Agreement, this Amendment or Applicable Law.

(ii) Notwithstanding anything set forth in the Agreement or this Amendment, Verizon shall be required to provide Line Splitting (or a network element on an unbundled basis) only where necessary facilities are available.

(d) Notwithstanding anything else set forth in the Agreement or this Amendment and subject to the conditions set forth in Section 1(c) of this Amendment:

(i) Verizon shall provide access to Line Splitting subject to charges based on rates and/or rate structures that are consistent with Applicable Law (rates and/or rate structures for access to Line Splitting, collectively, the "Rates" and, individually, a "Rate"). These Rates are as Verizon communicated to AT&T in a December 31, 2001 industry letter titled "UNE Rates for Existing Interconnection Agreements," as amended from time to time, and shall apply until such time as they are replaced by new rates as may be approved or allowed to go into effect by the Michigan Public Service Commission or the FCC from time to time, subject however, to any stay or other order issued by any court of competent jurisdiction for the State of Michigan.

2. Conflict between this Amendment and the Agreement. This Amendment shall be deemed to revise the terms and provisions of the Agreement to the extent necessary to give effect to the terms and provisions of this Amendment. In the event of a conflict between the terms and provisions of this Amendment and the terms and provisions of the Agreement, this Amendment shall govern, *provided, however*, that the fact that a term or provision appears in this Amendment but not in the Agreement, or in the Agreement but not in this Amendment, shall not be interpreted as, or deemed grounds for finding, a conflict for purposes of this Section 2.

3. Counterparts. This Amendment may be executed in one or more counterparts, each of which when so executed and delivered shall be an original and all of which together shall constitute one and the same instrument.

4. Captions. The Parties acknowledge that the captions in this Amendment have been inserted solely for convenience of reference and in no way define or limit the scope or substance of any term or provision of this Amendment.

5. Scope of this Amendment. This Amendment shall amend, modify and revise the Agreement only to the extent set forth expressly in Section 1 of this Amendment, and, except to the extent set forth in Section 1 of this Amendment, the terms and provisions of the Agreement shall remain in full force and effect after Effective Date.

SIGNATURE PAGE

IN WITNESS WHEREOF, the Parties hereto have caused this Agreement to be executed as of the Effective Date.

**AT&T COMMUNICATIONS OF
MICHIGAN, INC.**

VERIZON NORTH INC.

**CONTEL OF THE SOUTH, INC., d/b/a
VERIZON NORTH SYSTEMS**

By: _____

By: _____

Printed: _____

Printed: _____

Title: _____

Title: _____

AMENDMENT NO. 1

to the

INTERCONNECTION AGREEMENT

between

**VERIZON NORTH INC., F/K/A GTE NORTH INCORPORATED, CONTEL OF THE
SOUTH, INC., D/B/A VERIZON NORTH SYSTEMS**

and

**COMCAST PHONE OF MICHIGAN, LLC D/B/A COMCAST DIGITAL PHONE
FOR MICHIGAN**

This Amendment No. 1 (this "Amendment") is effective November 18, 2004 ("Amendment Effective Date"), by and between Verizon North Inc., f/k/a GTE North Incorporated, Contel of the South, Inc., d/b/a Verizon North Systems ("Verizon"), and Comcast Phone of Michigan, LLC d/b/a Comcast Digital Phone ("CDP"). (Verizon and CDP may hereinafter be referred to, each individually, as a "Party," and, collectively, as the "Parties").

WITNESSETH:

WHEREAS, Verizon and CDP are Parties to an Interconnection Agreement under Sections 251 and 252 of the Communications Act of 1934 (the "Act") for Michigan, which was effective October 21, 2004 (the "Agreement"); and

WHEREAS, on April 18, 2001, in the Order on Remand and Report and Order, *In the Matter of Implementation of the Local Competition Provisions in the Telecommunications Act of 1996, Intercarrier Compensation for ISP-Bound Traffic*, FCC 01-131, CC Docket Nos. 96-98 and 99-68, 16 FCC Rcd 9151 ("Order"), the Federal Communications Commission affirmed its prior determination that Internet traffic is not subject to reciprocal compensation under Section 251(b)(5) of the Act, but exercised its authority under Section 201 of the Act to establish a transitional plan for intercarrier compensation for Internet traffic; and

WHEREAS, in accordance with the Order, Verizon has elected to offer an optional reciprocal compensation rate plan for traffic subject to Section 251(b)(5) of the Act, under which such traffic exchanged between Verizon and a local exchange carrier or CMRS provider in a given state will be subject to compensation at the same rate applicable to intercarrier compensation for Internet traffic in that state under the terms of the Order; and

WHEREAS, CDP has elected to amend the Agreement to accept the optional reciprocal compensation rate plan for traffic subject to Section 251(b)(5) of the Act being offered by Verizon;

NOW, THEREFORE, in consideration of the promises and mutual agreements set forth herein, the Parties agree to amend the Agreement as follows:

1. Amendment to Agreement. Effective as of the Amendment Effective Date, the Agreement is amended as follows:

- 1.1 Notwithstanding any other provision of the Agreement, the following provisions shall apply to and be a part of the Agreement:

- 1.1.1 Reciprocal Compensation Rates:

- 1.1.1.1 Appendix A of the Agreement is amended by deleting the section I.A. "Reciprocal Compensation Traffic Termination" and replacing it with the following:

"Local Traffic Transport and Termination Rate

Amendment Effective Date and
thereafter -- \$0.0007 per minute of use."

- 1.1.1.2 The rates provided for in Section 1.1.1.1 above shall apply to the Parties in an equal and symmetrical manner.

- 1.1.1.3 The reciprocal compensation rates (including, but not limited to, per minute of use rates) billed by CDP to Verizon shall not exceed the reciprocal compensation rates (including, but not limited to, per minute of use rates) billed by Verizon to CDP.

- 1.1.1.4 The rates provided for in Section 1.1.1.1 above shall apply until such time as they are replaced prospectively by new rates as may be approved or allowed into effect from time to time by the Commission pursuant to FCC orders and FCC regulations, or by the FCC, subject to a stay or other order issued by any court of competent jurisdiction.

- 1.1.2 Reciprocal compensation shall not apply to traffic that is not subject to reciprocal compensation under Section 251(b)(5) of the Act.

- 1.1.3 "Internet Traffic" means any traffic that is transmitted to or returned from the Internet at any point during the duration of the transmission.
- 1.1.4 Local Traffic does not include any Internet Traffic.
- 1.1.5 Reciprocal compensation shall not apply to Internet Traffic.
- 1.1.6 The Parties' rights and obligations with respect to any intercarrier compensation that may be due in connection with their exchange of Internet Traffic shall be governed by the terms of the Order and other applicable FCC orders and FCC regulations.
- 1.1.7 The determination of whether traffic is Local Traffic or Internet Traffic shall be performed in accordance with Paragraphs 8 and 79, and other applicable provisions, of the Order (including, but not limited to, in accordance with the rebuttable presumption established by the Order that traffic delivered to a carrier that exceeds a 3:1 ratio of terminating to originating traffic is Internet Traffic, and in accordance with the process established by the Order for rebutting such presumption before the Commission).
- 1.1.8 A Party shall not be obligated to pay any intercarrier compensation for Internet Traffic that is in excess of the intercarrier compensation for Internet Traffic that such Party is required to pay under the Order and other applicable FCC orders and FCC regulations.

2. Termination. If the Order is stayed, vacated or modified, in whole or in part, by the FCC or another governmental entity of competent jurisdiction, each Party shall have the right to terminate this Amendment by written notice to the other Party. The termination shall be effective upon receipt of the notice of termination by the other Party. In the event of such termination of this Amendment, the language of the Agreement, on a prospective basis, effective with the effective date of the termination, shall revert to the language of the Agreement (including any other amendments to the Agreement entered into by the Parties on, before or after the Amendment Effective Date) as it would have existed if this Amendment had not been entered into by the Parties. The provisions of this Section 2 shall be in addition to and not in limitation of any other provisions of the Agreement (including, but not limited to, Section 9, "Regulatory Matters") that might apply if the Order is stayed, vacated or modified.

3. Scope of Amendment. Except to the extent set forth in Section 1 of this Amendment, the rates, charges and other provisions of the Agreement shall remain in full force and effect after the Amendment Effective Date. Nothing in this Amendment shall be deemed to amend or extend the term of the Agreement. The dates shown in Section 1.1.1.1 above are not intended to modify the term of the Agreement or to affect

either Party's right to exercise any right of termination it may have under the Agreement.

4. Conflict Between this Amendment and the Agreement. This Amendment shall be deemed to revise the rates, charges and other provisions of the Agreement to the extent necessary to give effect to the rates, charges and other provisions of this Amendment. In the event of a conflict between a rate, charge or other provision of this Amendment and a rate, charge or other provision of the Agreement, this Amendment shall govern.

5. Counterparts. This Amendment may be executed in one or more counterparts, each of which when so executed and delivered shall be an original and all of which together shall constitute one and the same instrument.

IN WITNESS WHEREOF, the Parties hereto have caused this Amendment to be duly executed and delivered by their duly authorized representatives as of the Amendment Effective Date.

COMCAST PHONE OF MICHIGAN, LLC
D/B/A COMCAST DIGITAL PHONE

VERIZON NORTH INC.,
CONTEL OF THE SOUTH, INC.,
D/B/A VERIZON NORTH SYSTEMS

By: _____

By: _____

Printed: Rian Wren

Printed: John C. Peterson

Title: Senior Vice President and
General Manager

Title: Director-Contract Performance and
Administration