

June 27, 2024

To: Michigan Public Service Commission (PSC) Staff  
From: Cody Davis, Electric Power Engineers, for Lawrence Berkeley National Laboratory<sup>1</sup>  
Re: Sizing Electric Service Panels and Utility Infrastructure for Residential Electrification and Distributed Energy Resource (DER) Adoption

On June 30, 2023, the Michigan PSC filed a [Grid Integration Study Report](#) in compliance with [Senate Resolution 143](#), which encouraged the Michigan PSC to undertake a study on reliability, interconnection, and related grid integration issues for distributed energy. One of the recommendations in the report addresses equipment sizing (emphasis added):

- **Minimum Level of Electric Service** - *To further enhance the adoption of residential DERs and EVs, exploration of a minimum level of electric service made available to all residential customers which would assure that the distribution system could **accommodate DERs and EVs** should be explored. The adoption of DERs and EVs may require customer service panel upgrades for older residential homes based on customer need. It is recommended that **the need for service panel upgrades be considered to incorporate increased adoption of DERs and EVs...***

PSC Staff requested Berkeley Lab to provide information related to minimum electric service panel requirements and utility infrastructure to support residential customer electrification and adoption of DERs such as photovoltaic solar and energy storage, in the context of Michigan's adoption of the National Electrical Code (NEC).

## Overview of Residential Electric Service Infrastructure Components and Sizing

Reliable electric service relies on individual components, owners of these components, and codes and standards that govern their design and construction. Figure 1 depicts several components for typical residential electric service.

---

<sup>1</sup> Contributions by Lisa Schwartz, Berkeley Lab

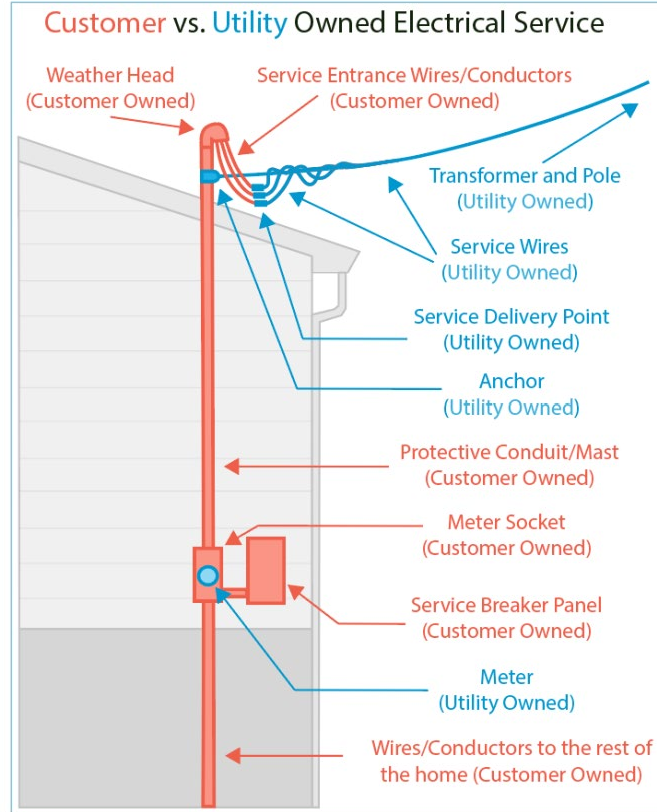

Figure 1. Illustrative Diagram of Electric Service Components<sup>2</sup>

### Customer Equipment

- The *service entrance*, *weather head*, and *conduit/mast* connect the utility supply conductors from the *service delivery point* to the home meter socket.
- The *meter socket* contains the connection points for the utility *meter*.
- The *service breaker panel* (“panel” or “breaker box”), which may be indoors or outdoors, contains the main circuit breaker and branch circuit breakers that protect against faults and fire risk.
- *Customer conductors* supply branch circuits within the home.

The customer is generally responsible for all components within and attached directly to the home, including conductors within the weather head and up to the junction with utility service conductors. Design and sizing for such components is governed by the NEC. Electricians design and construct these systems. In many areas, local inspectors are responsible for code enforcement.

<sup>2</sup> Courtesy Redwood Energy: <https://www.redwoodenergy.net/research/service-upgrades-for-electrification-retrofits-study-final-report-2>

*Customer conductors* (which encompass current-carrying electric wires, neutral wires, and grounding wires) are sized based on NEC methods for determining expected coincident load. Protective *circuit breakers* for each circuit are sized to ensure that any current exceeding the conductor rating, due to faults or excessive load, is interrupted before conductor damage or fire hazard conditions can occur. The *service breaker panel* (often referred to as “the panel” or the “breaker box”) is the enclosure that houses the collection of circuit breakers for the residence. The panel includes a main breaker sized (along with service wiring) for the maximum coincident load of the residence. Fuse boxes, generally found in older homes, serve the same protective function as breaker panels but employ single-use fuses instead of circuit breakers.

*Service breaker panels* are generally referred to by the size of the main breaker. Common sizes installed today include 100 Amps (A) and 200A. Legacy sizes include 60A and 80A. The *meter socket*, which provides connection points for the utility meter, is sized based on the size of the main breaker.

When new residential loads are added, available capacity on existing circuit breakers, capacity on the main breaker, and open panel spaces for new circuit breakers are all important considerations impacting electrical upgrade requirements and related costs. Upgrades to home wiring, especially for legacy knob and tube style wiring, may be necessary when the service panel is upgraded, which can result in significant costs. Costs vary from about \$5,000 to \$30,000 or more, depending on added loads, size of the home, and extent of rewiring needs.<sup>3</sup>

#### Utility Equipment

For residential electrical service, the utility is generally responsible for all components from the service entrance connection back to the distribution system primary conductors, including the following equipment depicted in Figure 2. For some underground residential services, the customer may be responsible for service conductors on their property back to the utility connection point at a transformer, secondary connection pedestal, or riser pole.

Utility equipment is governed by the National Electrical Safety Code (NESC), which is much less prescriptive than the NEC for equipment sizing. The NESC allows utilities and equipment manufacturers to develop their own equipment rating methods (see text box on NESC vs. NEC).

---

<sup>3</sup> <https://homeguide.com/costs/cost-to-rewire-a-house>

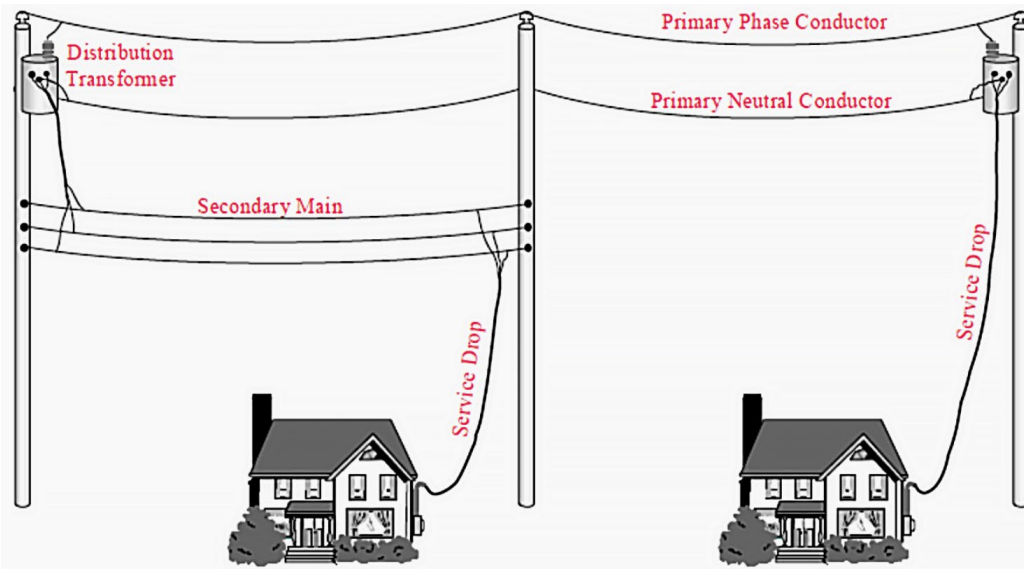

Figure 2. Transformer, Secondary, and Service Conductor Illustration<sup>4</sup>

- *Distribution transformers.* Also referred to as service transformers, these devices step down voltage from the primary system to the secondary voltage level necessary for serving customers (typically 120 Volt / 240 Volt service for residential customers). One transformer can serve as few as one customer or as many as several dozen customers or more. Transformer sizing is generally performed by the utility based on internal design standards and sizing calculation practices that are not generally publicly available.
- *Secondary conductors (secondary main).* Secondary conductors are low voltage conductors that connect distribution transformers to one or more sets of individual service conductors that connect to homes. Secondary conductors generally support multiple customers. One distribution transformer may have multiple runs of secondary extending out in different directions. Secondary conductor sizing is performed by the utility based on internal design standards and practices and stocked conductor sizes, factoring in the number and size of connected services as well as the physical distances involved to account for voltage drop.
- *Service conductors (or service drop or service wires).* Service conductors connect electric service for an individual home to secondary conductors or, in some cases, directly to distribution transformers. Service conductors are generally sized by the utility based on the size of the main breaker. Sizing may be increased based on the physical distances involved.

<sup>4</sup> <https://electrical-engineering-portal.com/primary-secondary-distribution-systems>

### **National Electrical Safety Code and National Electrical Code**

Utility infrastructure is typically governed by the National Electric Service Code (NESC), while customer equipment sizing is governed by the National Electric Code (NEC). The NEC tends to be significantly more conservative with regard to equipment ratings and sizing, as one of its primary purposes is to prevent house fires that may result from conductor overloads inside structures. Consequently, it is unlikely that the full maximum demand of the building electrical service will ever be used. The NESC is focused on public safety, but generally does not address equipment thermal ratings. Instead, the NESC allows utilities and manufacturers to develop ratings based on physical and expected environmental characteristics.

Historical design practices for both customer-side equipment and utility equipment have varied significantly over time and across geography. For example, in areas where natural gas has historically been available, electrical loads for space heating, water heating, and cooking tend to be much less common. Consequently, overall panel and circuit breaker sizes are often smaller and more likely to require upgrading for home electrification. Because of the long lifespan of distribution equipment, historical design practices have important impacts today. Much of the equipment still in-service was designed using practices and assumptions common at the time of construction. Updating design standards and sizing methods for new construction and identifying cost-effective ways to overcome the challenges created by legacy infrastructure are important enablers for DER and EV adoption and the electrification of end-uses traditionally served by fossil fuels.

### **Changes in Utility Equipment Ratings Due to Climate Change**

Most thermal equipment ratings for distribution equipment are based on assumptions related to ambient temperature, wind, heat dissipation, and other environmental factors. The assumptions used in these calculations are generally based on the most extreme expected conditions during a given season. As a result of climate change, seasonal high ambient temperatures, especially during summer, are expected to increase. That could require utilities to reduce equipment thermal capacity ratings. Utilities are starting to explore modifications to equipment thermal rating practices and the resulting impact on infrastructure and capacity. A recent [report](#) for Duke Energy's Carolina territory identifies the impacts and potential risks.

## Residential Customer Infrastructure Considerations

Customer adoption of a wide range of DER and electrification technologies are driving significant changes in electrical service equipment sizing, strategies, and practices. In addition to considering their impact in aggregate, it is useful to understand relative equipment sizes for DER and electrification technologies and identify key areas driving the need for electrical upgrades.

### **Residential Service Equipment: Upgrade Types and Sizing Determination**

When evaluating the need for upgrading residential electric service, the primary factor to consider is the type and age of the main breaker panel, the main breaker size, and number of breaker spaces available. Some specific older models of breaker panels or fuse boxes may be unsafe due to design flaws or manufacturing defects and must be replaced if any modifications are made to home electrical equipment. Unsafe equipment should be replaced regardless of whether a service is being upgraded for DERs or electrification, but a service upgrade may reveal such conditions and require that they be mitigated. If the main breaker panel requires an upgrade to increase the main breaker size, the meter socket also will likely require an upgrade. Under the 2023 NEC, upgrading the main breaker panel triggers a requirement to install a surge protective device.<sup>5</sup>

The NEC provides several methods for determining the required size of the main breaker. Proper application of these methods can help customers avoid the need for main breaker panel upgrades. NEC Section 220, Part III, provides sizing guidance based on the sum of connected branch circuits after the application of appropriate demand factors, which vary significantly by load type. NEC Section 220, Part IV, provides an alternate method of calculating main breaker size for new or existing dwellings based on square footage, branch circuit counts, and nameplate ratings of large equipment.

The NEC also allows for the use of metered data to determine whether new load additions to existing residential buildings require upgrading the main breaker. Maximum demand data in 15-minute intervals, typically available where utilities have deployed Advanced Metering Infrastructure (AMI), can be used for this purpose. Using AMI demand data for main breaker sizing provides a much more accurate alternative to demand factor estimates. Performance data reflect the actual maximum demand requirements of the residence and can potentially reveal that panel upgrades are not needed or may minimize required upgrades.

Other tools and methods can help reduce the need for service equipment upgrades:

- Using high-efficiency appliances can reduce overall electrical demand, providing more headroom for new loads.

---

<sup>5</sup> NEC 2023 215.18 Surge Protection (D) Replacement

- Low power versions of home appliances (e.g., supplied by 120 Volt (V) branch circuits instead of 240 Volt branch circuits) can help prevent the need to connect new circuits if panel space is limited.
- If breaker space is an issue but overall panel size is sufficient, installation of a subpanel can increase available space without requiring a full panel upgrade.
- Techniques like “plug sharing” or “circuit sharing” can allow for one breaker position to connect multiple loads (e.g., a clothes dryer and an EV charger) by allowing only one to operate at once.
- Load control techniques, which monitor load magnitudes and can trip certain loads if pre-set thresholds are exceeded, also can be used to prevent the need for main panel size upgrades and can result in significant cost reductions for customers. Energy storage systems can be used together with these techniques to potentially reduce the need to upgrade customer service equipment. The use of load control techniques for this purpose is enabled by the 2023 edition of the NEC.

## **Typical Equipment Sizes and Impacts of Electrification and PV Adoption**

### *Electric Vehicle Supply Equipment (EVSE)*

EV adoption and installation of EVSE (the charging equipment that manages the power transfer between the electrical service and the EV) are significant drivers of residential customer load additions and subsequent service upgrades. Level 1 EV chargers operate at 120V and typically draw around 1-2 kilowatt (kW).<sup>6</sup> They have minimal impact on infrastructure needs but have relatively slow charging speeds. While level 1 chargers are sufficient for most residential applications, customers frequently opt instead for level 2 chargers, which use 240V and can provide between 7 and 19 kW of power to charge the EV significantly faster.<sup>7</sup> Most residential level 2 EVSE installations draw between 16A and 48A, requiring a 20–60A breaker. A J.D. Power survey found that 68% of EV or plug-in hybrid owners have access to a level 2 charger at home.<sup>8</sup>

### *Electrification of Space and Water Heating, Cooking, and Clothes Drying*

Electric service infrastructure impacts of building electrification (the conversion of fossil fuel-fired home appliances) depend on the installed technology and its maximum power needs. Following are prominent examples:

- *Heat Pumps*. These devices can be used both for space heating and cooling. Sizes vary, generally requiring breakers from 20A to 60A. Because heat pumps often replace existing air-conditioning equipment in addition to the furnace, they often do not drive

---

<sup>6</sup> [https://en.wikipedia.org/wiki/SAE\\_J1772](https://en.wikipedia.org/wiki/SAE_J1772)

<sup>7</sup> <https://www.transportation.gov/rural/ev/toolkit/ev-basics/charging-speeds>

<sup>8</sup> <https://www.kbb.com/car-news/study-ev-owners-not-happy-with-home-charging-either/>

the need for service upgrades. However, upgrades may be necessary for heat pumps using electric backup heating elements, depending on the existing breaker size.<sup>9</sup>

- *Electric Water Heaters*. While water heating accounts for a relatively high percentage of home energy consumption, conventional tank water heaters generally have lower maximum power draw and require smaller breaker sizes, typically in the 15–30A range. Tankless water heaters have much larger electric demands and are subsequently far more likely to require modifications to the breaker panel.
- *Electric Stoves*. Electric stoves have a very high maximum power draw, but are a relatively small portion of overall home energy consumption. Typical breaker sizes are 40– 60A for both conventional and induction models.
- *Electric Clothes Dryers*. Electric clothes dryers already are much more common than their natural gas counterparts.<sup>10</sup> Typical breakers for electric clothes dryers are 30A.

While all these electrification technologies are commonly supplied by 240V circuits, there also are lower power options (120V) for heat pumps, water heaters, and dryers that can help limit the need for home electrical modifications. Emerging technologies also are incorporating batteries within the design to reduce maximum power draw for stoves, heat pumps, and water heaters.

#### *Aggregate Electrification Impacts on Residential Service Equipment*

Buildings with 200A panels are more likely to accommodate a higher degree of end-use electrification than buildings with 100A panels. Homes that are older (especially those built before 1960) or smaller (especially those under 1,000 square feet) are much more likely to have 100A panels. A building's ability to service electric space and water heating, cooking, and clothes drying, as well as EV charging and existing branch circuit outlet loads, depends on equipment size, floor area, and pre-retrofit peak demand, all inputs for NEC load calculations. Due to their relatively high demand, electric stoves may be more difficult to accommodate in a 100A panel, depending on the overall size of the home and the presence of other electric appliances. Similarly, level 2 EVSE is more likely to require demand-limiting technologies or panel upgrades in order to connect alongside other electrification technologies in a home with a 100A panel.

If an electrical panel has sufficient capacity to service additional loads, availability of an open breaker position may still pose a constraint. This constraint depends on both the number and voltage of electrified components under consideration. In addition, very large homes, homes with multiple level 2 EV chargers, and homes with heated pools or other less common large

---

<sup>9</sup> Backup natural gas, propane, or oil heat reduces the need for a panel upgrade, but may be inconsistent with local or state air quality goals.

<sup>10</sup> <https://www.eia.gov/consumption/residential/data/2020/hc/pdf/HC%203.6.pdf>



loads may require a service panel upgrade in order to support the connection of new large loads.

Municipal or county permits typically are required to increase panel size. The utility is usually involved in panel size upgrades to relocate the service wire to the new meter base and move or upgrade the meter and therefore has information about the addition of new loads. Where a panel size increase is not required, utilities may be unaware of new EV charging or electrification installations unless they occur as part of a utility incentive program or EV-specific rate.<sup>11,12</sup> Depending on historical utility sizing practices (discussed in more detail later in this memo), this after-the-fact identification creates the potential for unidentified overloads on utility secondary conductors and service transformers. This issue impacts buildings with electrical panels of any size, but is likely more common in buildings with larger panels (e.g., 200A) because they are less likely to require interactions with utilities that would occur if the customer's overall service size increased (e.g., from 100A to 200A).

### Photovoltaic (PV) Solar Impacts

Residential PV sizes typically range from 5 kW to 18 kW, measured by the maximum Alternate Current output rating of the inverter(s). Installations of 7.6 kW or 7.68 kW are very common, as 7.68 kW is the largest size that can be connected to a 40A breaker, and 80% of residential systems are smaller than 10 kW.<sup>13</sup> Larger sizes typically require modifications such as installation of a subpanel, installation of PV-ready panels,<sup>14</sup> or use of line-side tap connections.

Because solar PV is not a load addition, it does not inherently drive requirements for electrical panel upgrades. Even 100A service can accommodate most typical residential solar inverter sizes. Other factors, however, can lead customers adding solar to upgrade their electrical panel size. If the existing panel is old, unsafe, or smaller than 100A, an upgrade may be required to support any modifications to the home electrical system. If customers are anticipating future electrification (e.g., adding an EV charger), they may elect to upgrade their service while an electrician is onsite for PV-related upgrades to avoid scheduling a future service call and minimize overall costs.

Line-side tap connections are particularly critical to consider. They often can be installed without significant modifications to existing home wiring and can help avoid the need for electrical panel upgrades. Instead of connecting through the main breaker panel or a subpanel,

---

<sup>11</sup> For example, see <https://www.cpuc.ca.gov/news-and-updates/all-news/cpuc-decision-makes-california-first-state-in-the-nation-to-allow-submetering-of-electric-vehicles#:~:text=The%20California%20Public%20Utilities%20Commission,a%20technology%20know n%20as%20submetering>

<sup>12</sup> <https://emp.lbl.gov/publications/snapshot-ev-specific-rate-designs>

<sup>13</sup> <https://emp.lbl.gov/tracking-the-sun>

<sup>14</sup> <https://www.eaton.com/us/en-us/catalog/low-voltage-power-distribution-controls-systems/solar-power-centers.html#tab-2>

a line-side tap creates a new junction between the utility meter and the main breaker panel, using a separate breaker or fused disconnect for protection. Figure 3 demonstrates this type of connection.<sup>15</sup> Line-side tap connections are commonly used to connect solar PV because they typically do not require modifications to the electrical panel, do not require an open breaker position, can support solar panel sizes above 7.68 kW, and most utilities allow their use. (See text box on connecting DERs for backup and resilience.)

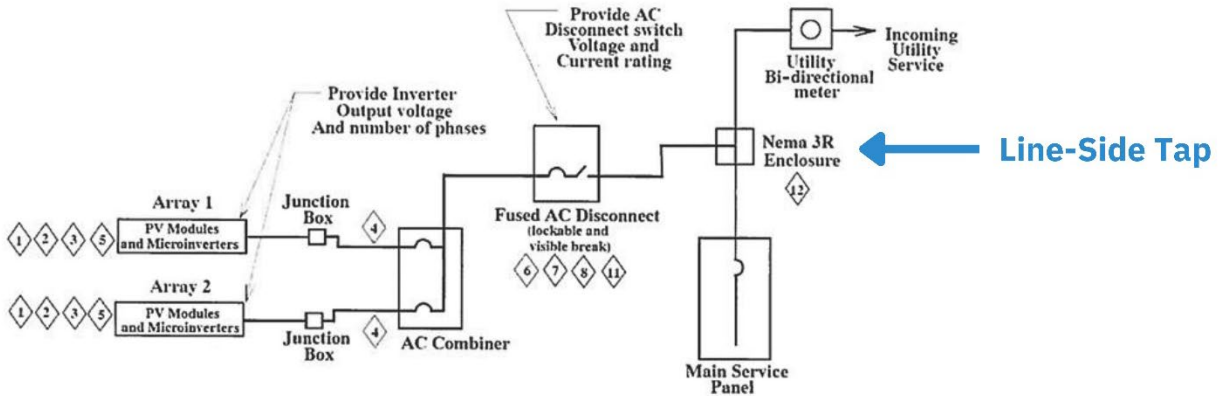

Figure 3. Line-Side Tap PV Connection Between Utility Meter and Main Service Panel

<sup>15</sup> <https://www.ameren.com/-/media/missouri-site/files/environment/solar/sample-one-lines.ashx>  
(line-side tap added)

### **Connecting DERs for Backup Power and Resilience**

Many customers interconnect DERs such as solar with battery energy storage to power their home during grid outages. This generally requires physically disconnecting from the distribution system using a transfer switch. Many modern home backup power configurations use an intelligent transfer switch capable of automatically disconnecting from the grid and managing customer DERs to provide power.

One common configuration mimics the line-side tap set-up, replacing the NEMA 3R enclosure with the smart transfer switch to enable whole-home backup power. Some vendor smart transfer switches also include connection points for DERs (on the customer-facing side of the transfer switch) to take full advantage of the benefits of the line-side tap style of connection without requiring a separate connection enclosure. Other backup power configurations use a separate subpanel for critical loads and the back-up DER, with a transfer switch installed between the subpanel and the customer's main panel. This is more commonly used when backup generation is not large enough to serve the full home load.

## **Utility Service Infrastructure Considerations**

Historical utility practices for transformers, secondaries, and service conductors have changed considerably over time and vary significantly by region and according to design assumptions. Modern practices are typically enshrined in utility design standards and calculation tools. For example, utilities use internal design guidelines for housing subdivisions to make decisions about sizes of services transformers use and size and maximum distances of secondary conductors and service conductors. These decisions are typically based on the number of customers served, relative distances involved, and expected electrical load of the new homes. The adoption of DER and residential electrification technologies has important impacts on each of these infrastructure components.

### **Service Transformers**

Growth of electrification and solar PV is driving utilities to reconsider the sizing of existing and new service transformers. For existing installations, estimating transformer loading to detect or prevent overloads and maintain reliability is a critical focus. For new installations, accuracy of sizing calculations that incorporate EVSE and other electrification technologies is central to ensuring that the selected transformer meets the full electrical needs without resulting in unnecessary costs from oversizing.

Typical service transformers for single-phase residential service generally range from 5 kVA to 167 kVA, with 25 kVA and 50 kVA sizes most common. Utilities generally perform sizing calculations using expected coincident demand for the total number of connected customers. That expected coincident demand is much lower than the total non-coincident demand of all

connected customer service panels. Many utilities allow for coincident load to exceed service transformer nameplate ratings during peak load periods. The short-term thermal impacts of high load on the transformer typically do not significantly impact equipment life. For overhead transformers, mounted on poles and connected to overhead primary conductors, device loading may be allowed at values significantly above the nameplate rating (e.g., up to 170% of the nameplate rating). For padmount transformers, which sit on a pad on the ground and are served by underground primary conductors, natural thermal cooling is generally less effective. For padmount equipment, device loading may still exceed the nameplate rating, though generally not by as much (e.g., up to 130% of the nameplate rating). These practices and specific thresholds vary by utility.

For residential PV, transformer sizing calculations generally assume full nameplate solar output for all systems and zero customer load. While this may seem conservative, there are practical factors that support the use of such assumptions for transformer sizing when historical data is unavailable. Because solar PV is environmentally driven, the outputs of multiple systems in the same geographic area are highly coincident and can occur during periods of relatively light loading. Because the number of customers on an individual transformer is generally very small, common system-level minimum load assumptions (e.g., 15% of peak load) may not be reliable estimates for the minimum load on a service transformer, leading to load not being considered in sizing when assessing PV impacts. Where possible, the use of historical AMI data can improve sizing by allowing for an appropriate amount of load and existing DER contribution to be considered in lieu of conservative assumptions.

For electric vehicle charging, transformer sizing calculations may assume that up to the full nameplate charging load occurs during the existing peak load period for up to all customers that will be served by the transformer. Such assumptions are highly likely to be overly conservative.

- First, the coincidence of EV charging load for multiple customers on the same transformer is driven by customer behavior, rather than an external environmental factor, and consequently tends to be less coincident by nature.
- Second, the degree to which EV charging load coincides with other peak load drivers (generally referred to as the “demand factor”) may be assumed to be as high as 100% in the sizing calculation (representing full nameplate loading), but is often notably lower. The demand factor of EV charging load and the coincidence across multiple EV charging customers varies significantly based on customer charging strategies, retail electricity rates and utility incentives, and other approaches to EV charging management.

The relative lack of historical data and relatively small number of customers served by individual service transformers are primary drivers for conservative demand factor

assumptions (e.g., up to 100% of nameplate capability) for EV sizing calculations. That increases the likelihood of deploying larger sizes of transformer than are actually needed. Improving accuracy of the demand factor used for EV load calculations is a key focus area for utilities and jurisdictions that want to reduce the risk of transformer oversizing. In addition, managed EV charging can help ensure that EV charging does not result in transformer overloads when managed for this purpose.

There is significant utility interest in updating design practices for service transformers, especially for residential subdivisions, based on expected EV growth. Homes that are not initially fitted with EV chargers may add them in the future. And many homes, especially those that already have 200A panels, may add EV charging loads without notifying the utility. Consequently, utilities have incorporated or are considering incorporating EV charging load into design calculations and transformer sizing, even if EV chargers are not included at the time of construction.

Migrating from using 25 kVA transformers to 50 kVA transformers as the standard size for new subdivisions is a common consideration. Deploying larger transformers from the start can reduce the risk of future overloads and minimize future upgrade costs, but raises the initial cost. This practice is typically applied to new construction, where the utility considers the full lifespan of the new equipment. For existing service transformers, proactive upgrades are much more difficult to execute effectively. It is difficult to predict customer adoption with enough specificity to make investments at the service transformer level. Instead, using AMI data to monitor transformer loading and using EV rates and programs as a means of making utilities aware of new EV loads can help reduce transformer overload risk and identify specific necessary upgrades.

Proactive transformer upsizing is significantly less common for residential solar PV. Since customers must go through the application process for PV interconnection, utilities are aware of new installations and can evaluate transformer sizing at the time of the application. This dramatically reduces the risk of PV-driven transformer overloads. In addition, distribution system upgrades needed to support customer-hosted PV are typically paid for by the applicant. Proactive transformer upsizing for PV would shift such costs to all ratepayers.

## **Secondary Conductors**

Sizing practices for secondary conductors generally follow the same processes used for transformer sizing, but with additional considerations for the physical conductor lengths, voltage drop, and load distribution along the secondary conductors. For example:

- A single transformer may have one set of secondary conductors that feeds homes to the north and a second set of secondary conductors that feeds homes to the south.
- A transformer may have a single set of secondary conductors that feeds all customers served by the transformer.

Design practices typically focus on sizing secondary conductors (by selecting from a predetermined set of standard conductors) to prevent overloads and ensure that the total voltage drop on the transformer, secondary conductors, and service conductors do not exceed prescribed thresholds. Limiting voltage drop to 4V on a 120V base service, for a total maximum voltage drop of 3%, is a relatively common practice for new construction.

Legacy design and construction practices for secondary conductors can often create challenges in identifying and preventing equipment overloads. Utility records for secondary conductors are often very poor or inaccessible at scale. Utilities frequently excluded secondary conductors during transitions from paper to digital mapping systems due to cost and complexity. Many utilities do not have data in their systems of record for the sizes, distances, or connectivity of secondary conductors. This makes it impractical to include them in power flow models or identify potential overloads using AMI data. Utilities can capture this information for all new construction and equipment replacements, as it is otherwise difficult and costly to obtain at scale. Upgrades to existing secondary conductors are generally considered alongside service transformer upgrades, known load additions, or home electrical panel size upgrades. Secondary conductor overloads are a potential risk if the utility is not aware of a load addition (e.g., when a customer installs EVSE but does not need to upgrade their electrical panel) or if the existing transformer can accommodate a known load addition but the secondary conductor may not be reviewed during that process.

### **Service Conductors**

Service conductors (which connect individual homes to secondary conductors or directly to service transformers) are generally sized to meet the maximum expected demand for electrical service to an individual building. In some cases, this may be smaller than the customer's panel size. For example, polymer-covered 1/0 triplex conductor (rated for 160A<sup>16</sup>) may be used to connect a 200A service. This is allowable because the service conductor size and panel size are governed by different standards.

In contrast to transformers and secondary conductors, the risks of service conductor overload due to electrification are low in most cases. Because the size of service conductors for new construction are based on the size of the residential electric service panel, the potential for the customer to add new loads on their electrical panel is accounted for inherently. For existing services that do not require a panel upgrade to add load, there may be some risk of overload, depending on historical utility design and construction practices.

For existing residential service that requires a panel upgrade to add load, service conductor overload risk is minimal because the utility is almost always contacted to disconnect the old meter base and to connect the service wires to the new meter base. For overhead services, the

---

<sup>16</sup> <https://www.prioritywire.com/specs/Triplex%20Service%20Drop.pdf>

customer's electrician can observe the utility service conductors directly, identify the size, and communicate to the utility the need for a service wire upgrade. For underground services, the conductor size often is not directly observable until the existing meter base is opened. In such cases, however, the process of disconnecting and reconnecting service conductors is more involved and generally identifies if a conductor upgrade is needed.

As a result of transitioning from paper to digital mapping systems, utility records for service conductor size and distance are often inaccessible or of poor quality. Utilities can capture this information for all new construction and equipment replacements. It is difficult and costly to obtain this data after the fact.